



Model ANE-1 Differential Pressure Anemometer

Specifications - Installation and Operating Instructions



Tubing Adapter

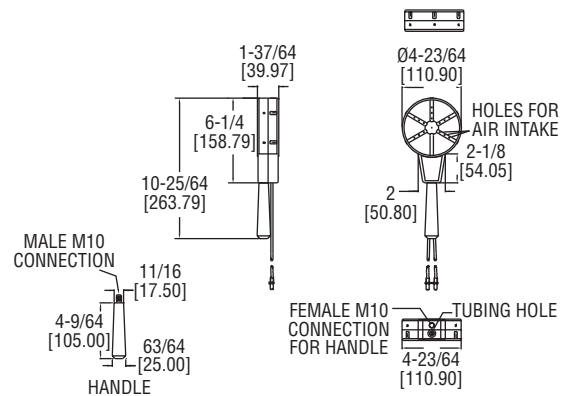

The Model ANE-1 Differential Pressure Anemometer is a robust and durable bi-directional anemometer with no moving parts or sensing electronics. With the installed tubing, the ANE-1 connects easily to any manometer or applicable pressure sensing device and is capable of measuring a wide velocity range. The air velocity range and accuracy is dependent on the installed manometer, and the ANE-1 retains the accuracy as long as it is dust free. The ANE-1 is made from high quality ABS plastic, comes with a convenient handle, and includes 5' of blue and 5' of red silicone tubing (2 mm ID x 4.5 mm OD) with removeable adapter sized 2 mm OD to 3/16" OD that has two removeable 5" clear silicone 3/16" ID x 3/8" OD tubing versatile process options.

Assembly

The ANE-1 requires simple assembly of the handle. Locate the handle and ANE-1 head. Line up the male screw connection of the handle to the female screw connection of the ANE-1 head. Screw the handle in a clockwise direction until secure. Do not overtighten.

HOW THE ANE-1 DIFFERENTIAL PRESSURE ANEMOMETER WORKS

The ANE-1 Differential Pressure Anemometer consists of two pressure sensing internal parts designed to measure the velocity pressure. The device consists of several equally spaced holes.

The 3 holes on each of the branches, on the front and rear of the device, face downstream or upstream of the airflow and sense total pressure. The holes on the outer portion of the housing senses static pressure.

The total and static pressures are averaged and provide pressure in the installed tubing. The pressure differentials across the tubing connections constitute the output velocity pressure.

MEASURING VELOCITY

Connect the red tubing to the positive pressure port and the blue tubing to the negative pressure port on the pressure sensing instrument. The ANE head should be placed into the air stream as indicated by the arrows. Pressure readings should always be positive. If negative readings are obtained, there may be a leak or blockage in the pressure tubing or they may be incorrectly connected.

SPECIFICATIONS:

Service: Clean air only.

Wetted Materials: Anemometer: ABS; Tubing: Silicone; Handle: Phenolic.

Dimensions:

Tubing: 2 mm ID x 4.5 mm OD;

Adapter: 2 mm OD to 3/16" OD connections.

Temperature Limits: 23 to 122°F (-5 to 50°C).

K-Factor: 0.843.

Process Connections: 2 removeable 5" (12.7 cm) tubing 3/16" ID.

Weight: 7.7 oz (220 g).

Calculations for air velocity can be based on the following data:

$$\text{Air Velocity} = 4006 \times k \sqrt{\frac{P_v}{D}}$$

Where: P_a = Pressure in inches of water

D = Air density in #/cu. ft. typical

K = K-factor of units (0.843)

$$\text{Air Density} = 0.057 \times \frac{P_a}{T}$$

Where: P_a = Barometric pressure in inches of mercury

T = Absolute temperature (indicated temperature °F plus 460)

Flow in CFM = Duct area in square feet x air velocity in FPM.

MAINTENANCE/REPAIR

The Model ANE-1 requires no routine maintenance. The Model ANE-1 is not field serviceable and should be returned if repair is needed. Field repair should not be attempted and may void warranty.

WARRANTY/RETURN

Refer to "Terms and Conditions of Sales" in our catalog and on our website. Contact customer service to receive a Return Goods Authorization number before shipping the product back for repair. Be sure to include a brief description of the problem plus any additional application notes.