



Series 490 Wet/Wet Handheld Digital Manometer

Specifications - Installation & Operating Instructions



Series 490 Digital Manometers are versatile, hand-held, battery operated manometers available in several basic ranges from 0-15.0 psi up to 0-500 psi. All models measure either positive, negative or differential pressures with $\pm 0.5\%$ of full scale accuracy. You can select from up to seven common English and metric pressure units so conversions are not necessary. A memory function allows storage of up to 40 readings for later recall and a backlight provides auxiliary lighting for hard-to-see locations. Also standard are a hold feature plus both visual and audible overpressure alarms.

SPECIFICATIONS

Service: Compatible, non-combustible gases & liquids.

Wetted Materials: Type 316L SS.

Accuracy: $\pm 0.5\%$ F.S., 60 to 78°F (15.6 to 25.6°C); $\pm 1.5\%$ F.S. from 32 to 60°F and 78 to 104°F (0 to 15.6°C and 25.6 to 40°C).

Pressure Hysteresis: $\pm 0.1\%$ of full scale.

Pressure Limits: See chart.

Temperature Limits: 32 to 104°F (0 to 40°C).

Storage Temperature Limits: -4 to 176°F (-20 to 80°C).

Display: 4-digit LCD (.425 H x .234 W digits).

Resolution: See chart.

Power Requirements: 9 volt alkaline battery. Battery included but not connected.

Weight: 14.1 oz (400 g).

Connections: Two 1/8" (3.18 mm) female NPT.

Agency Approvals: CE.

Model Number	English Range	Metric Range	Maximum Pressure
490-1	0-15.00 psi	0-103.4 kPa	30 psi (2.7 bar)
490-2	0-30.00 psi	0-206.9 kPa	60 psi (4.13 bar)
490-3	0-50.00 psi	0-344.8 kPa	100 psi (6.89 bar)
490-4	0-100.0 psi	0-689.5 kPa	200 psi (13.78 bar)
490-5	0-500.0 psi	0-3448 kPa	1000 psi (68.9 bar)
490-6	0-200.0 psi	0-1379 kPa	400 psi (27.57 bar)

INSTRUCTIONS

Battery Installation

The unit is shipped with a separate 9 volt alkaline battery which must be installed before operation. Remove the two screws holding the bottom endcap in place and remove the endcap. Connect the battery to the enclosed battery clip observing correct polarity. Be careful not to trap wires between the battery, case or foam pads which retain the battery. This could make it difficult to install the battery or remove it later for replacement. Be sure the rubber gasket is properly seated in the gasket channel of the endcap and replace endcap. Note that the endcap will only fit one way because the holes are slightly off-center. Place the "Z" shaped wrist strap clip in one of the screw recesses and replace the screws. Do not overtighten the screws. Attach wrist strap to clip.

When battery replacement becomes necessary, use only a 9 volt alkaline type such as a Duracell® MN1604, Eveready® 522 or equivalent. Zinc-carbon types, often labeled Heavy-duty are not recommended because of the increased potential for leakage. Alkaline batteries are also a better value because they last up to three times longer in this device.

On-Off Operation

The on-off control is a toggle function. Press and release the ON/OFF key once to turn unit on; again to turn it off. If the manometer is left on with no activity for approximately 20 minutes, unit will turn itself off to conserve the battery.

Display Backlight

The Model 490 includes a display backlight to allow use in the dark or in poor lighting conditions. Manometer must be switched off before this feature can be activated. Next, press and hold the ON/OFF key down. After about 1 second the backlight will come on and remain lighted for approximately 2 minutes after which it will turn itself off to conserve battery life.

Zeroing Pressure Reading

Potential inaccuracy due to temperature effects can be minimized by re-zeroing immediately before use. To zero the display, vent both ports to atmosphere so no pressure is applied to either port. Press the ZERO/STORE key and - - - will be momentarily displayed as zeroing occurs. Zeroing is not possible when the memory mode is in use. It must be done before selecting that function.

If the unit is accidentally zeroed with pressure applied to one of the ports, the pressure reading might display incorrectly. To correct, vent the pressure ports to atmosphere and press the ZERO/STORE key to zero the unit.

Pressure Connections

Dual 1/8" female NPT connections are provided. For a single positive pressure, connect tubing to port marked + and vent opposite port to atmosphere. To measure differential positive pressure, connect higher positive pressure to port marked + and lower positive pressure to port marked -. Manometer will indicate the difference between the two.

Selecting Pressure Units

Up to seven pressure units are available. The display will indicate the current selection. To change to different units, use the UNITS/LOC key. Each touch will cause an advance to the next choice. The selected units will remain in memory even when power is shut off. This way, your preference will always be displayed after the initial selection.

Display Hold

There may be situations where you want to temporarily retain a reading. The Model 490 includes a Display Hold feature which freezes the current reading and holds it in the display until cleared. To activate this operation, momentarily press the HOLD/MEMORY key when the pressure you want to save is displayed. A HOLD indicator will appear in the display to indicate that the reading shown is frozen. To return to normal operation, press the HOLD/MEMORY key again. The HOLD indicator will disappear and the current pressure will again be shown.

Memory Function

A memory function is included in the Model 490 that allows you to store up to 40 pressure readings for later review or recording. This feature is especially valuable for multipoint pressure measurements. The readings are stored in non-volatile memory so they will be retained even if the unit is shut off or the battery is removed.

Storing Pressure Readings

To store a reading, press and hold the HOLD/MEMORY until ST01 is displayed then release the key. Next, press ZERO/STORE key to save current reading to ST01 memory location. A beep will sound indicating that the reading has been saved. As each reading is saved, the memory location display will advance to the next number. To resume pressure measurement, press the HOLD/MEMORY key again. Note that in the memory mode, the display zero function is not available. To zero the display, you must first exit the memory mode and then press the ZERO/STORE key.

Viewing Stored Readings - Selecting a Location

To view the contents of memory, press and hold the HOLD/MEMORY until RD01 is displayed then release the key. Next, press UNITS/LOC to view other memory location. To resume pressure measurement, press the HOLD/MEMORY key again.

Clearing Memory

To clear the contents of memory, press and hold the HOLD/MEMORY until CLR is displayed then release the key. Next, press ZERO/STORE key to clear all previously stored readings. During this operation - - - - will be displayed. Once memory is cleared, the current pressure will be displayed.

Exiting Memory Mode

To exit the memory mode, press the HOLD/MEMORY key again and the unit will return to normal operation.

Dampening Function

The dampening feature allows the user to enter a dampening number from 1 to 16 (default value = 2). Entering a larger number increases the amount of readings that are averaged for each display update.

In order to access the dampening feature, follow the instructions below:

1. Press and hold the HOLD/MEMORY button. The upper right portion of the LCD scrolls through a menu selection (HOLD, ST01, RD01, CLR and DAMP). When "DAMP" is shown, release the HOLD/MEMORY button. This selects the dampening feature.
2. Once "DAMP" is selected, a number is shown in the upper right portion of the LCD, along with the current pressure reading. This number is the dampening number. Adjust the number up by pressing the ZERO/STORE button or down by pressing the UNITS/LOC button. The LCD update rate slows as the number increases from 1 to 16. Therefore, for best results, choose the smallest number that provides a stable pressure reading.
3. Once the pressure reading is stable, press and release the HOLD/MEMORY button to store the dampening value.

Overpressure Alarm

A visual indicator and audible alarm are provided to alert the operator that pressure has exceeded the operating range of the unit. Exceeding the range will not damage it or affect calibration as long as the maximum rated pressure is not exceeded. **Do not exceed the maximum rated pressure of the manometer. Doing so will cause permanent damage to the sensor, may rupture the housing and/or cause injury.** The maximum pressure is shown on the rear label and on page 1 of these instructions.

Low Battery Indicator

A weak battery can cause improper operation or inaccurate measurements. A low battery indicator is provided on the display to show when the battery needs replacement. Although the unit might appear to function and indicate properly, the accuracy of readings cannot be guaranteed when the LOW BAT indicator is illuminated. Replace the battery with a fresh one. Do not leave an exhausted battery in the unit due to potential leakage.

Optional 3-Way Valve

For certain hydronic applications it is beneficial to measure the differential pressure with the assistance of the optional attached 3-way valve. (See Fig. A).

Begin with valve V1 open and valves V2 and V3 closed (See Fig. B). Slowly open valves V2 and V3. Once the pressure has stabilized and is equal on the high and low side, valve V1 can be closed and normal operation can proceed.

To ensure proper pressures will be detected by the 490, use the bleed fitting provided with this valve package (See Fig. A). Before applying pressure to the process connections, turn V1 to the open position and back off the bleed screw. Next apply pressure. After the flowing liquid is free of bubbles, retighten the bleed screw. Before taking the 490 offline from the process, open valve V1 then close valves V2 and V3.

Maintenance

The Series 490 is not field serviceable and should be returned if repair is needed (field repair should not be attempted and may void warranty). Be sure to include a brief description of the problem plus any relevant application notes. Contact customer service to receive a return goods authorization number before shipping.

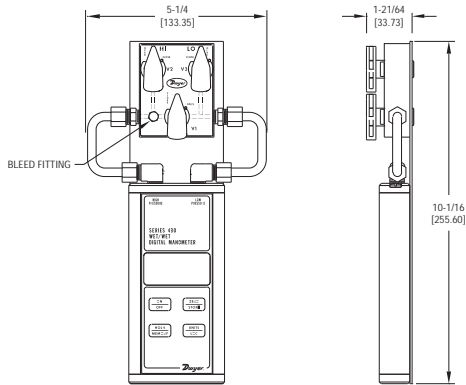

Fig. A

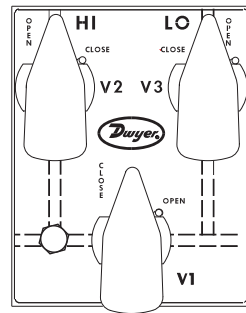

Fig. B

Duracell® is a registered trademark of The Gillette Company

Everready® is a registered trademark of The Everready Battery Company, Inc.