

User's Manual

Dewpoint Transmitter
Model XDT

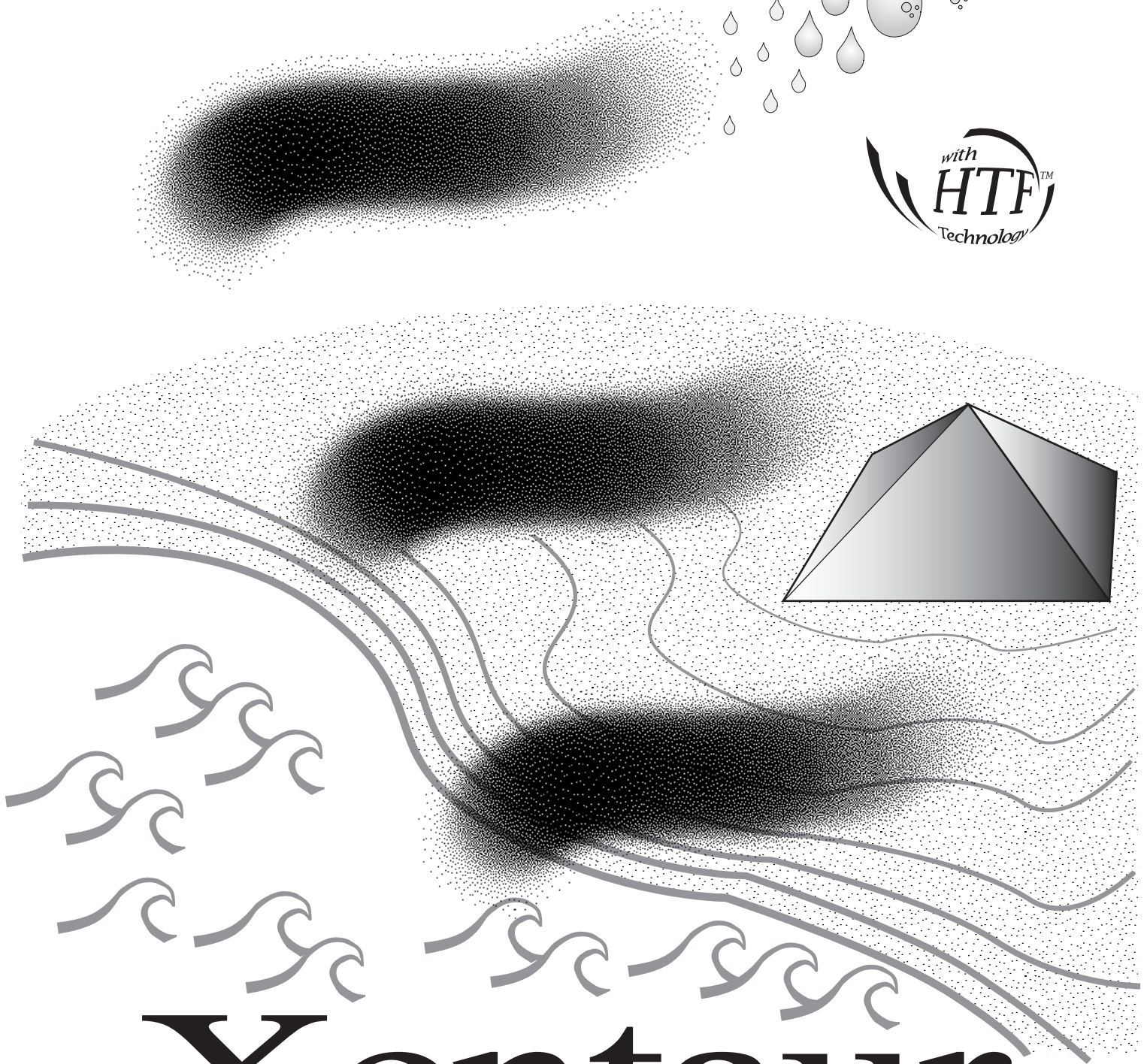

Xentaur

When calling your representative for technical support, please have your serial numbers available. The Sensor and Instrument Serial Numbers are on the instrument, also see section 3.4.4.4.

Sensor Serial No.: _____

Instrument Serial No.: _____

Your Representative is:

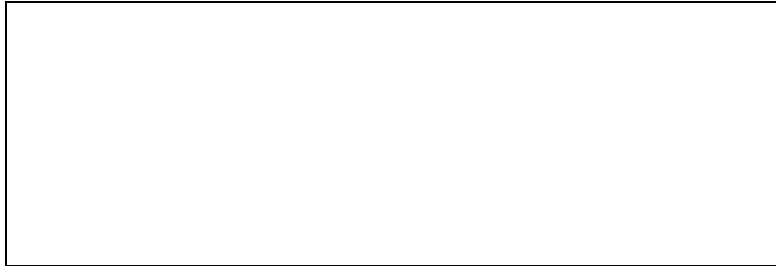

Except as may be provided by contract, this document and all specifications and drawings contained are the property of Xentaur Corporation, are issued in strict confidence, and shall not be reproduced or copied or transmitted, in any form or by any means, or used as the basis for the manufacture or sale of apparatus, programs, or services without permission.

Check the Internet for updates; the latest revision of this manual is available in Adobe Acrobat format at: <http://www.xentaur.com>

Document No.: XDO.01.D.0000 Rev.2.3 5/10/05

Copyright © 2000,2004,2005 by Xentaur Corporation

Xentaur reserves the right to change or modify the product specification and / or appearance at any time without notice. Therefore, the information in this document is subject to change without notice and does not represent a commitment on the part of Xentaur Corporation.

The customer agrees that in accepting and using this instrument Xentaur Corporation's liability arising from or in any way connected with this instrument shall be limited exclusively to performing a new calibration or replacement or repair of the instrument or sensor, at Xentaur's sole option, as covered by Xentaur's warranty. In no event shall Xentaur be liable for any incidental, consequential or special damages of any kind or nature whatsoever, including but not limited to lost profits arising from or in any way connected with this instrument or items hereunder, whether alleged to arise from breach of contract, express or implied warranty, or in tort, including without limitation, negligence, failure to warn or strict liability.

Swagelok, Cajon are trademarks of SWAGELOK Co.
Acrobat is a trademark of Adobe Systems Incorporated
Epson is a registered trademark of Seiko Epson Corporation
Microsoft Windows is a registered trademark of Microsoft Corporation
HTF is a trademark of Xentaur Corporation
SpanCheck is a trademark of Xentaur Corporation
The Xentaur Logo is a trademark of Xentaur Corporation

Examine the XDT package for damage or mishandling. If any damage is evident notify the carrier and request an inspection.

Unpack the box, it should contain: The XDT, sensor in desiccant container, connected cable, and this manual.

PLEASE READ THIS MANUAL IN WHOLE, PRIOR TO INSTALLING OR REMOVING THE SENSOR FROM ITS SHIPPING CONTAINER.

This manual is organized in three sections:

Section 1 is an overview of the XDT.

Section 2 describes the sensor and sampling techniques.

Section 3 describes the instrument's electrical, mechanical, and user interfaces.

This manual is intended for those already familiar with the installation, use and maintenance of analytical or process instrumentation.

Those acquainted with other Xentaur dewpoint measurement products such as the LPDT or the XPDM, will benefit from the commonality of the user interface.

Warning Labels

The symbols shown below appear on the instrument to alert the user of potentially hazardous conditions.



Protective Grounding Conductor Terminal
Bornier de L'Ecran de Protection
Schutzerde



CAUTION - Risk of Electric Shock
ATTENTION - Risque de Décharge Électrique
ACHTUNG - Hochspannung Lebensgefahr



CAUTION - Refer to documentation
ATTENTION - Se Réferer aux Documents Jointes
ACHTUNG - Beachten Sie beiliegende Dokumente

Warranty

This instrument is warranted to be free from defects in workmanship and materials. Liability under this warranty is limited to servicing, calibrating, and replacing any defective parts of the instrument returned to the factory for that purpose. Fuses are specifically excluded from any liability. This warranty is effective from the date of delivery to the original purchaser. The equipment must be determined by Xentaur to have been defective for the warranty to be valid. This warranty applies as follows:

- one year for electronics
- one year for mechanical failures to the sensor
- six months for calibrations

If damage is determined to have been caused by misuse or abnormal conditions of operation, the owner will be notified and repairs will be billed at standard rates after approval.

Maintenance Policy

In cases when equipment fault is suspected, please notify your representative of the problem, be sure to provide them with model and serial numbers. If the problem can not be resolved, then ask for a Return Authorization Number (RAN) and shipping instructions. Issuance of an RAN does not automatically imply that the equipment is covered by our warranty, that will be determined after we receive the equipment. Pack the equipment in a suitable box with sufficient padding, include the RAN number on your paperwork, and send the equipment, prepaid, to the designated address. Equipment returned without an RAN, or with reversed shipping or import/export charges, will not be accepted

If the warranty has expired, or the damage is due to improper use or exposure of the equipment; then the repair facility will provide an estimate and wait for approval before commencing repairs.

For your convenience a Return Authorization Request Form is provided in appendix N, it must be completed and sent back to the provided destination in order to obtain a RAN.

Table of Contents

1.0 Overview of the XDT	1
2. Sensor and Sampling Techniques	3
2.1 Precautions using the sensor	3
2.2 Sensor Technical Specifications	4
2.3 Sensor Installation & Sampling Techniques	4
2.3.1 In-situ Installation	5
2.3.2 Extractive Installation	6
2.4 Mechanical Installation	7
2.5 Troubleshooting unexpected readings	8
3. Instrument	9
3.1 Precautions using the XDT	9
3.1.1 Electromagnetic Compatibility Considerations	9
3.2 Instrument Technical Specifications	10
3.3 Installation	11
3.3.1 Instrument Mechanical Installation	11
3.3.1.1 XDT-PM (DIN43700) Enclosure Installation	11
3.3.1.2 XDT-NEMA (IP65) Enclosure Installation	11
3.3.1.3 XDT-OEM bare board Installation	11
3.3.2 Electrical Connections	12
3.3.2.1 Connecting Power	12
3.3.2.1.1 AC Mains Electrical Power Connection	13
3.3.2.1.2 Low Voltage DC Powered Option - Electrical Power Connection	13
3.3.2.2 Sensor Connection	13
3.3.2.3 Wiring the Alarm Contacts	13
3.3.2.4 Interfacing to the Analog Output	14
3.3.2.5 Interfacing to the RS-232 option	15
3.4 Operating the Instrument	15
3.4.1 Starting up	15
3.4.2 Display Conventions	16
3.4.3 Push Buttons	16
3.4.4 Operating State	17
3.4.4.1 Viewing Dewpoint Mode	17
3.4.4.2 Alarms	19
3.4.4.3 Start Calibration	20
3.4.4.3.1 SpanCheck™ Mode	21
3.4.4.3.2 Single Point Self Calibration, manual or scheduled	22
3.4.4.4 Viewing Serial Number Mode	25
3.4.5 SetUp State	25
3.5 Resettable Audio-Visual Alarm Option (NFPA compliant)	28
3.6 Troubleshooting the Instrument	29
3.7 Maintenance	31
Glossary	33
Appendix A: Flow Diagram of Operating State User Interface	37
Appendix B: Flow Diagram of Set-Up State User Interface	39

Appendix C: Sensor Mechanical	40
Appendix D: Optional Sensor Fittings.....	41
Appendix E: XDT Circuit Board Dimensions	42
Appendix F: Sensor/SpanCheck™ Theory of Operation	45
Appendix G: Dewpoint Response time Analysis	46
Appendix H: Sample Gas Filter Considerations.....	48
Appendix I: XDT Grounding Considerations.....	49
Appendix J: Analog Output vs. Dewpoint.....	50
Appendix K: RS-232C Interface Protocol	52
Appendix L: Procedure for Exchanging XDT Sensors.....	55
Appendix M: Uncertainty in LBS & ppmV calculations	56
Appendix N: Certifications - Approvals - Conformity	57
Appendix O: Return Authorization Number Request Form.....	59
<i>Index</i>	<i>61</i>

1.0 Overview of the XDT

The XDT is a microprocessor based hygrometer, for measuring moisture content in gases in the range from -100°C to $+20^{\circ}\text{C}$ dewpoint depending on the sensor ordered. The XDT uses the Xen-taur Hyper Thin Film HTF™ sensor which is encapsulated in sintered stainless steel, thus it is capable of coming into contact with a wide variety of environments. However one should keep in mind that the sensor is a delicate device and it should be handled accordingly.

The measurement is displayed on the instrument's custom LCD, can be transmitted by optional analog and digital outputs, and can control optional programmable relays. Four front panel buttons provide the user with a rich feature set. The XDT's advanced design allows it to be housed in a variety of enclosures.

The XDT has an impressive set of dewpoint measurement capabilities in terms of accuracy, stability, response time etc. The specifications of the sensor are discussed in section 2.2, while the specifications of the instrument are discussed in section 3.2. A summary of the standard and optional features & capabilities of the XDT are listed below as an overview aid to the user.

Standard Features/Capabilities

- Locking of instrument, preventing unintentional changes
- SpanCheck™: - automatic recalibration using room air, all instruments pre-calibrated at factory.
- Capability to enter up to 15 NIST/NPL traceable calibration points at factory, depending on order.
- Manual Self Calibration: a single point calibration using a known standard gas. High accuracy can be maintained even in the most harsh applications.
- Pressure correction: built-in software calculation of dewpoint at a pressure different than the measurement.
- Cable length compensation: user initiated automatic self measuring software.
- Universal global autoranging AC supply 100-250VAC, 50/60Hz
- Instrument and Sensor: UL, cUL, and CSA listed/recognized; CE electromagnetic compatibility certified

Optionally ordered Features/Capabilities

- Password protected Locking of instrument, preventing unauthorized changes
- Alarm Relays - programmable set points, error handling, and hysteresis. Up to 3 alarm relays may be ordered. On-display legends indicate relay states.
- Audio Visual Alarm- complies with recommendations of NFPA 99, 1996 edition, audio reset and test buttons.
- Analog Output- factory set voltage or user selectable 4/20 - 0/24 mA. Includes installation testing features. User selectable range (low & high point) of analog output.
- RS-232C interface - allowing the user digital data access to the instrument.
- Interval-timer-scheduled Self Calibration, a single point calibration using a known standard gas, can operate an electrically actuated switchover valve for unattended calibrations
- Large variety of threads for sensor mounting into sample
- Low voltage DC power operation 15-30VDC
- Intrinsically Safe Approved NEC and ATEX standards (UL & DEMKO) configurations

2. Sensor and Sampling Techniques

2.1 Precautions using the sensor

The Xentaur HTF™ Al₂O₃ sensor is designed and field proven to be highly reliable, rugged and maintenance free. However the user should consider the following precautions:

- If the instrument is used to measure moisture in toxic, flammable, or explosive gases, the sample outlet must exhaust to a safe place.
- Check the sample line for leaks before and after connecting.
- If measuring gases at high pressures, make sure the sample system is depressurized before installing or removing the sensor probe, or other items e.g. filters.
- To avoid the need for prolonged dry-down (when expecting to measure dewpoints dryer than –65°C), do not expose the sensor to room air longer than necessary (1 - 2 minutes). Thus, do not open the sensor container before you are ready to install the sensor.
- The sensor container has desiccant to keep the sensor dry during shipping and to avoid damage due to condensation. Close the container immediately after removing the sensor to avoid degradation of the desiccant.
- Do not throw away the sensor container, you may use it again to transport the sensor between locations, to store it between uses or to ship it back to the factory for certification. The container can be attached to the sensor cable, by trapping the cable with the lid strap.
- Do not expose the sensor to corrosive gases such as gases containing chlorine, ammonia or HCl. (SO₂ can be monitored when the moisture content is low).
- Except for the XTR65W sensor:
 1. Do not expose the sensor to liquid water, as it may get damaged.
 2. Do not breathe directly onto the sensor, as condensation may form which could damage the sensor element.
- Do not install the sensor near heat sources such as radiators or air ducts.
- Do not install the sensor in places subject to extreme mechanical vibration or shock. If this is not avoidable, use resilient mounting. If in doubt, call your representative.
- Do not disassemble the porous metal filter encapsulation, as this will damage the sensor and void your factory warranty.
- Prior to installation of the probe, ensure that no contaminants are present in the system (e.g. oil, liquid water).

2.2 Sensor Technical Specifications

Type:Hyper Thin Film HTF™ high capacitance Al₂O₃.

Dewpoint range:.....XTR-100: -148°F to +68°F (-100°C to +20°C)
 XTR-65: -85°F to +68°F (-65°C to +20°C).
 XTR-60: (-60°C to +20°C)
 XTR-LQ: for use in liquids

Capacitance:.....15nF to 200nF.

Accuracy:±5.5°F (±3°C) refer to appendix M for accuracy expressed in other units of measure.

Repeatability:±0.9°F (±0.5°C).

Response time:refer to Dewpoint Response time analysis in Appendix G.

Operating Temperature:14°F to 158°F (-10°C to +70°C), non-condensing

Storage Temperature:-40°F to +176°F (-40°C to +80°C), non-condensing

Sample Flow range:(linear velocity @ 1ATM): Static to 100m/s.

Enclosure:encapsulated in 100μ sintered stainless steel.

Calibration method:Highly uniform sensors calibrated at low dewpoint and SpanCheck™, sensor saturates at dewpoint above +68°F (+20°C). NIST/NPL traceable multi-point factory calibration available optionally.

Pressure operating range:...Standard:500 PSI (34 bar).
 Optional:5,000 PSI (340 bar).

Mechanical connections:.....14mm x 1.25mm sparkplug threads, and ¾”-16 threads, standard
 Optional configurations: G1/2, 1/2”NPT, 5/8”-18 and others

Electrical connections:Female BNC connector.

Sensor signal cable:RG58 coaxial cable, or for lengths greater than 100’ RG6 coaxial cable, max 17,000pF.

Approvals/Classifications: CE for electromagnetic compatibility, accredited laboratory tested and certified
 Hazardous Locations:
 UL Class I,II, Division 1, Groups A,B,C,D,E,F,G intrinsically safe when installed per drawings
 XDT.00.D.6001 or XDT.00.D.6002 or XDT.00.D.6003

DEMKO 05 ATEX 0505798X  II 1 G EEx ia IIC T6 -20°C≤Ta≤+60°C Intrinsically Safe when installed per drawing XDT.00.D.6001

2.3 Sensor Installation & Sampling Techniques

Keep in mind that the moisture content at the sensor is not only due to the moisture of the gas being measured, but also due to desorption of water from tubing, trapped moisture (at the inter-connection points, valves, filters and other hygroscopic materials in the system), leaks in the system, and others. Thus the measurement may vary from the expectation, and therefore care should be taken in choosing the sampling technique utilized in the measurement. Factors such as gas pressure, flow rate, materials of construction, length and diameter of tubing, number of interconnecting fittings, dead space in tubing and manifolds; will influence the measurement value and response time.

The high capacitance HTF™ sensors can be installed either directly in the line to be sampled (in-situ), or in a slip stream of a sample system (extractive).

To assure a long and accurate performance of the sensor, it should be protected from contaminants such as liquids (water, oil etc.), and particulates. The sintered stainless steel sensor encapsulation protects from particulates larger than 100 microns, finer particulates (e.g. from degraded desiccant or rust) should be filtered with a particulate filter with suitable capability, do not use hygroscopic filter materials. Refer to Sample Gas Filter Considerations Appendix H.

2.3.1 In-situ Installation

In-situ installation is recommended only for measurements where the gas pressure is expected to vary little, the gas is expected to be free of contaminants, the gas temperature is within the operating specifications of the sensor, and there is no chance of liquids coalescing. Examples of applications suited for in-situ installations are: pure gases, output of desiccant dryers (for instrument air), glove boxes, etc. For most other applications in-situ installation should be avoided for the following reasons:

- Sample conditioning is almost always necessary to avoid exposure of the sensor to liquid water and other contaminants, such as hydrocarbons, which may damage the sensor or affect accuracy over time.
- Variations in line pressure affect the reading of the sensor because dewpoint varies with pressure.
- If the gas line is under pressure, it is more likely that water condensation occurs which may damage the sensor.
- Under a pressurized system removal of the sensor without the installation of isolation valves can be dangerous.

If in-situ installation is required, bypass mounting is preferable; make sure to install the sensor at the upper surface of the gas line to minimize its exposure to liquid water, should condensation occur, the XTR65W sensor is best suited for these applications. Also consider the need to isolate (depressurize) before installing or removing the sensor.

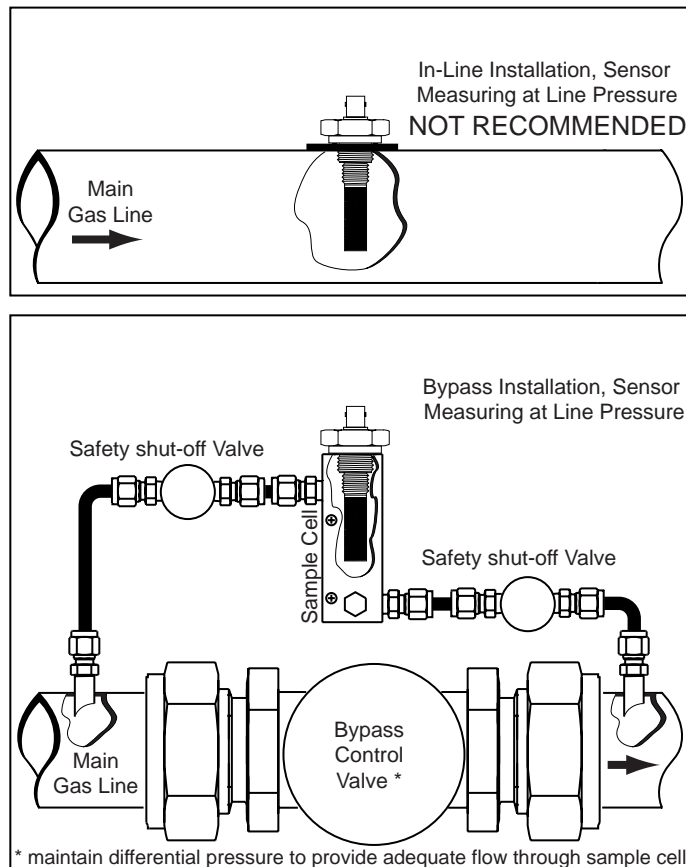

The sensor measures the dewpoint at whatever pressure it is at. The instrument is equipped with a pressure correction feature which allows reporting the dewpoint at a different pressure.

2.3.2 Extractive Installation

For extractive installations we recommend our sample system ESS, which may be equipped with a variety of features, such as: isolation valve, coalescing or particulate filter, pressure regulator, calibration sample injection or extraction port, pressure gauge, flow meter, weatherproof enclosure. Refer to the ESS literature for more information.

If the resources to make your own sample system are available, the following two diagrams may be used as a guideline to configure a simple system.

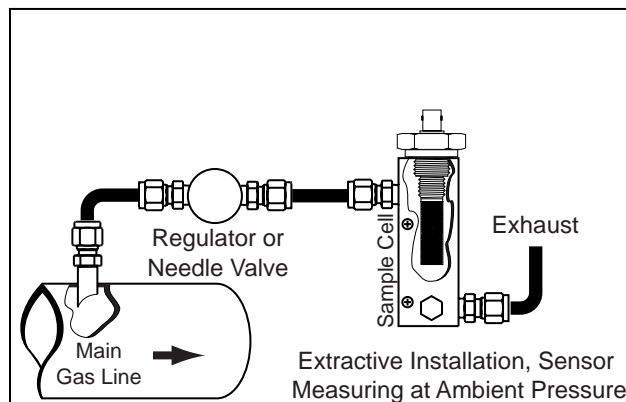
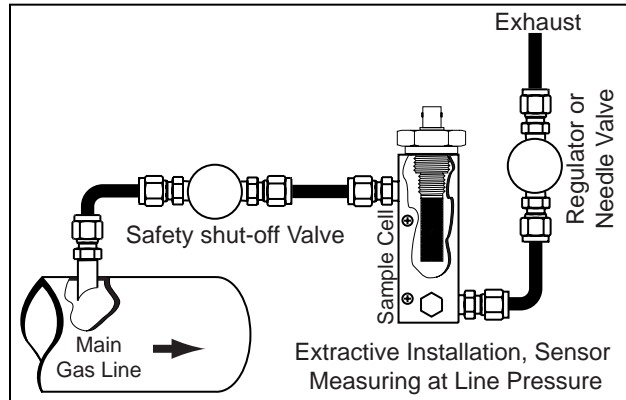

It is generally recommended to measure at ambient pressure for the following reasons:

- The readings will not be affected by variations in line pressure.
- The risk of exposing the sensor to liquid water is significantly reduced.
- ppm readings are computed for a pressure of one atmosphere (1 bar); and have to be corrected using software in the instrument, or a pressure monograph, or calculator if the sensor is measuring at different pressures.

If readings at line pressure are necessary, it is recommended to measure at ambient pressure and to use the instrument's pressure compensation feature to calculate the dewpoint at line pressure.

Refer to Viewing Dewpoint Mode section 3.4.4.1.

Please make sure that:

- The sample is taken from the upper surface of the main gas line. This avoids problems with contamination. The sample should be taken away from pipe line walls where flow rates may be low, and dewpoint changes may lag.
- For dewpoints dryer than -40°F , use stainless steel tubing only. For dewpoints -40°F and wetter, copper tubing is acceptable. Do not use *plastic, rubber or tygon* tubing under any circumstances, as measurements would be incorrect and/or response time slow due to water retention

inside these materials.

- Try to run pipes to the sensor upwards, so that contaminants tend to fall back into the main line.
- Keep the length of the sample line to the sensor as short as possible.
- Use small diameter pipes (1/4" or 1/8" OD).
- Use sufficient flow rates (e.g. 1 l/min with 6 feet of 1/8" piping is adequate). The flow rate will influence the systems' response time.
- Do not install any devices upstream of the sensor, such as other measuring systems, flow meters etc., which are not absolutely necessary as these are potential leak sources.
- Installation of a coalescing and / or particulate filter ahead of the sensor is desirable to prevent any liquid or particulate contamination of the sensor.
- If filters are used upstream of the sensor, make sure these contain non-hygroscopic filter materials only. Refer to Sample Gas Filter Considerations Appendix H.
- If pressure regulators, shut off valves etc. are used upstream of the sensor, make sure these do not contain rubber or other hygroscopic materials.

2.4 Mechanical Installation

The sensor probe has two thread sizes for mounting to the sample cavity where the dewpoint will be measured, see appendix C. Various optional fittings are available for direct connection into existing system openings, refer to appendix D. Ask your representative for a Sample Cell, if you do not have the ability to provide an appropriate sample cavity mounting. If the 3/4"x16 thread is used then the sensor will seal against the wall of the sample cell with the provided Viton A O-ring. If the 14mm x 1.25 spark plug thread is used then an additional Viton gasket must be installed to provide the proper seal. Ask your representative for this gasket, it is available free of charge. To prevent any leaks, tighten the fitting into the sample cavity, with a 1 1/4" wrench, 1/8 turn past finger-tight to assure metal-to-metal contact.

The sensor can be removed from the fitting by unscrewing it. Make sure that the sensor is securely fastened to the fitting (the tension washer should be compressed), so that it does not come loose during use.

2.5 Troubleshooting unexpected readings

If erroneous readings are suspected on a newly acquired instrument, compare the serial number engraved on the sensor sintered filter, to the label on the instrument. The two should be the same; if they are not, the instrument may not be calibrated with the installed sensor. To troubleshoot other problems, identify the unexpected reading category in the following table, and consider the possible causes and appropriate diagnostic action and remedy.

Symptom	Possible Cause	Diagnostic/Remedy
Reading is not changing	Condensation in sample system.	Condensation will occur if the temperature of the sample system, at any point is below (colder) the dewpoint temperature of the sample gas. Once having formed, the sample reaching the sensor will have a dewpoint equal to the temperature of the condensation, regardless of the dewpoint of the source gas.
Slow Response	<ol style="list-style-type: none"> 1. Water vapor in the system. 2. Flow rate too low. 3. Sample pipe too large and/or too long. 4. Unsuitable sample pipe. 5. Leaks. 6. Hygroscopic materials in sample system 	<p>It is usually more satisfactory to bleed a sample gas at atmospheric pressure through the sensor sampling chamber, and to use 1/8" (3mm) o.d. sample pipe.</p> <p>See below re sample pipe material, also see section 2.3</p>
Dry Reading	SpanCheck™, wrongly set, or faulty Sensor.	Verify SpanCheck™, or return sensor for full calibration to your representative.
Wet Reading	Leak in system or use of unsuitable pipe.	Cure the leak, or replace unsuitable pipe with copper or stainless steel. Flexible connections should be made with PTFE pipe. NEVER use rubber or plastic pipe.
	Comparison of readings with manual cooled-mirror instrument.	This type of indicator reads about 10°C dry at about -50°C dewpoint due to temperature gradients within the device. The error increases at drier levels.
Display Shows SAT	Prolonged exposure to wet gas.	Dry down the sensor, install sensor in either a known dry gas stream i.e. instrument quality air or dry nitrogen, or place sensor in a dry can or bottle of desiccant and seal the container from outside air (the shipping container is designed for this purpose) also see section 3.4.4.3.1
Display Shows SHr	1. Instrument Failure	Disconnect cable from input terminals, if the instrument still reads SHr the problem is with the instrument. However, if the instrument reads oPn then reconnect the cable to the input terminals and check possible causes 2 or 3.
	2.Short circuit on sensor cable or connections.	Disconnect cable from sensor and if meter still reads SHr, cure the short circuit in the cable or connections or replace cable; otherwise check the sensor.
	3.Short circuited sensor.	Disconnect cable from sensor and note that the meter reading returns to oPn. Use a new sensor, or apply approximately 20V DC to the sensor MOMENTARILY with the sensor in a known dry condition. Polarity is not important, but the contact MUST be very brief or the sensor may be damaged. Consult with your representative for a circuit diagram.
Display Shows oPn.	1. Instrument failure.	Short the SIG and SHIELD contacts of the sensor input terminal, if the instrument reads SHr the problem is in the cable or sensor, otherwise return the instrument for service.
	2. Open circuit on cable.	Disconnect cable from sensor and short center pin of plug to the outer shell. If the display still shows oPn, repair cable.
	3. Open circuit on sensor.	Check sensor connection or replace sensor.

For non-sensor related problems (e.g. no reading on instrument) refer to section 3.6

3. Instrument

3.1 Precautions using the XDT

The XDT uses state-of-the-art microelectronics to provide a compact full functioning instrument. The user should consider the following precautions when using any sensitive electronic device.

- Observe the appropriate electrical safety codes and regulations. Consult with National Electrical Code article 400, and/or other nationally or locally recognized procedures relevant to your installation. You will most probably require a disconnect switch, and power wiring. The power cord provided with the instrument is intended only for testing, it may not be used for a permanent field wired installation. This instrument is UL approved for field wiring.
- If weather proofing is required consult your representative for an optional enclosure (XDT-NEMA). The XDT is not intended for direct outdoor installation unless it is appropriately housed.
- Do not install the unit near heat sources such as radiators or air ducts.
- Do not install the unit in places subject to extreme mechanical vibration or shock. If this is not avoidable, use resilient mounting. If in doubt, call your representative.
- Before handling the circuit board outside its enclosure, discharge any static electricity buildup on your person by touching a grounded metal object. Integrated circuits can be damaged by electrostatic discharge, handling the circuit board by its edges and avoiding touching any metal components on the board decreases the chances of electrostatic damage.

3.1.1 Electromagnetic Compatibility Considerations

The XDT has been designed and verified by testing to meet the requirements of the EC Council EMC Directive 89/336/EEC, for Industrial, Scientific & Medical equipment. The sensor ground is isolated from the AC ground, logic ground, 4-20mA loop return, etc.; however they are also shunted with a 0.1uf capacitor 1M Ohm resistor, and a 33V Transient Voltage Suppressor; this prevents electrostatic buildup, noise pick-up, and in conjunction with the internal fuse protects the instrument from over-voltage inputs. Please consider the following electromagnetic interference issues during installation:

- In order to provide an acceptable noise environment for the XDT or any other digital equipment in the proximity of switched inductive loads, it is recommended that there be varistors placed across the inductors to keep down the high voltage spikes during transitions.
- Any circuitry which is activated by relay contacts should account for the contact bounce, one simple debouncing method is placing a capacitor across the relay contacts.
- AC power wiring should be routed as far away from the XDT and its wiring as practical.

3.2 Instrument Technical Specifications

- Enclosure:XDT-OEM bare board
XDT-NEMA tabletop or surface mount, watertight IP65 tested, and NEMA 12 tested
XDT-PM panel-mount, DIN 43700 dimensional standard, optional NEMA 12 type protection gasketing available
- Dimensions & Weight:.....XDT-OEM: 4.25" x 5.15" x 2.25", 0.6 lbs (fully optioned) without cables.
XDT-NEMA: 4.73" x 6.3" x 3.55", 2.1 lbs (fully optioned) w/cables.
XDT-PM: 5.67" x 2.84" x 2.95" DIN 43700 standard, 1.3 lbs (fully optioned) w/cables.
refer to appendix E for detailed dimensions
- Environmental Range:Operating temperature of electronics: 14°F to 122°F (-10°C to 50°C)
Storage temperature of electronics: -40°F to 176°F (-40°C to 80°C)
Humidity: 0 to 90% RH non-condensing
Altitude: 0 to 6500 feet (2000 meters)
- Mains Supply Voltage:100 to 250VAC autoranging, 50/60Hz, 10VA, internal 0.5A, 250V fast acting fuse.
Optionally the instrument may be configured with DC power capability: 15 to 30VDC 0.5A.
- Electrical connections:21 contact pluggable screw terminal block, 1.3mm diameter pins on 5mm centers.
- Wiring requirements: For AC Power: 18AWG or heavier wire, an external means for disconnecting the power source is required to meet National Electrical Code requirements.
For Sensor signal: RG58 coaxial cable, or RG6 for cable longer than 100'. A 6 foot cable is provided as a standard, other lengths ordered as options. When changing cable, refer to cable compensation section.
- Input resolution:0.1°C dewpoint.
- Indicators:3.5 digit backlit LCD with custom legends, audible indicator.
- Engineering units:°C, °F, PPM, LBS H₂O/mm scf, gm H₂O/m³.
- Controls:.....Four push buttons, user's selections are stored in EEPROM.
- Outputs:..... Analog: voltage by order or current user selectable 4-20mA or 0/24mA. Linear to the selected engineering units, the range is programmable. Output resolution is 0.1°C dewpoint, linearity 1%, max load resistance 500 Ohms.
Digital RS-232C (9600,8,E,1), can interface to a Personal Computer or other RS-232 device.
- Alarm relay contacts:Ordinary use, explosion-proof housed, and safe area instruments: 10A, 250VAC or 30VDC.
Intrinsically Safe Div 2 instruments use hermetically sealed relays: 3A, 120VAC
- Isolation:Sensor is isolated from power ground, analog output and RS-232, but they are shunted with a 33V transorb, a 1M Ohm resistor and 0.1uF capacitor. Refer to Electrical Connections section.
- Approvals/Classifications: CE for electromagnetic compatibility, accredited laboratory tested and certified
UL, cUL and CSA for ordinary field wired use
Hazardous Locations: UL Class I,II, Division 1, Groups A,B,C,D,E,F,G intrinsically safe when installed per drawing XDT.00.D.6001/6001a/6002/6003/6004

3.3 Installation

3.3.1 Instrument Mechanical Installation

The XDT is available in several different physical configurations. Please follow the instructions below, which describe the instrument being installed. The sensor installation is discussed in Section 2: Sensor and Sampling Techniques.

3.3.1.1 XDT-PM (DIN43700) Enclosure Installation

The standard XDT-PM is provided with two clip-on compression panel mounting brackets. These brackets allow the user to mount and secure the instrument onto a properly cutout panel (137mm x 67mm). Consult with drawing in appendix E, for all relevant dimensions. Installation is accomplished by attaching 2 clips, one on each side of instrument, and inserting the instrument into the panel cutout. Pressure must be applied along edges of instrument until it is firmly seated.

The XDT-PM may be ordered with an environmental seal option. This option provides a gasket (installed at the factory) to seal the face plate to the enclosure box, and a gasket (to be installed by the user) to seal the enclosure box to the user's mounting panel. To achieve a good environmental seal the XDT-PM must be mounted onto a rigid flat panel with a cutout according to the specified dimensions, using the provided panel gasket and all four provided mounting brackets. The instructions listed below should be followed.

- If the clip-on mounting brackets are installed on the instrument enclosure, remove them.
- Make sure that the panel gasket is flat and even around the box bezel. Handle the gasket carefully as not to tear it.
- Insert the box into the user's panel cutout, consult with drawing in appendix E for proper panel cutout dimensions.
- Attach all four mounting brackets to the instrument enclosure from the rear of the panel, make sure they are fully locked in.
- Use a screwdriver to tighten the mounting bracket screws, all four screws should be tightened uniformly, the panel gasket should be compressed.

3.3.1.2 XDT-NEMA (IP65) Enclosure Installation

The instrument can be installed as a wall or panel surface mount, by making use of four screw holes on the back (bottom) of the instrument enclosure. Open the instrument cover for access to these screw holes. They are located at the corners of the enclosure and outside of the NEMA seal. Do not drill other mounting holes, as you may compromise the seal. Refer to Appendix E for all relevant dimensions.

3.3.1.3 XDT-OEM bare board Installation

When mounting the circuit board in a user supplied enclosure using standoffs, be sure to use insulating washers. Refer to Appendix E for mounting hole dimensions and required mounting dimensions.

3.3.2 Electrical Connections

All connections are made via a 21 contact, pluggable screw terminal block referred to as P1.

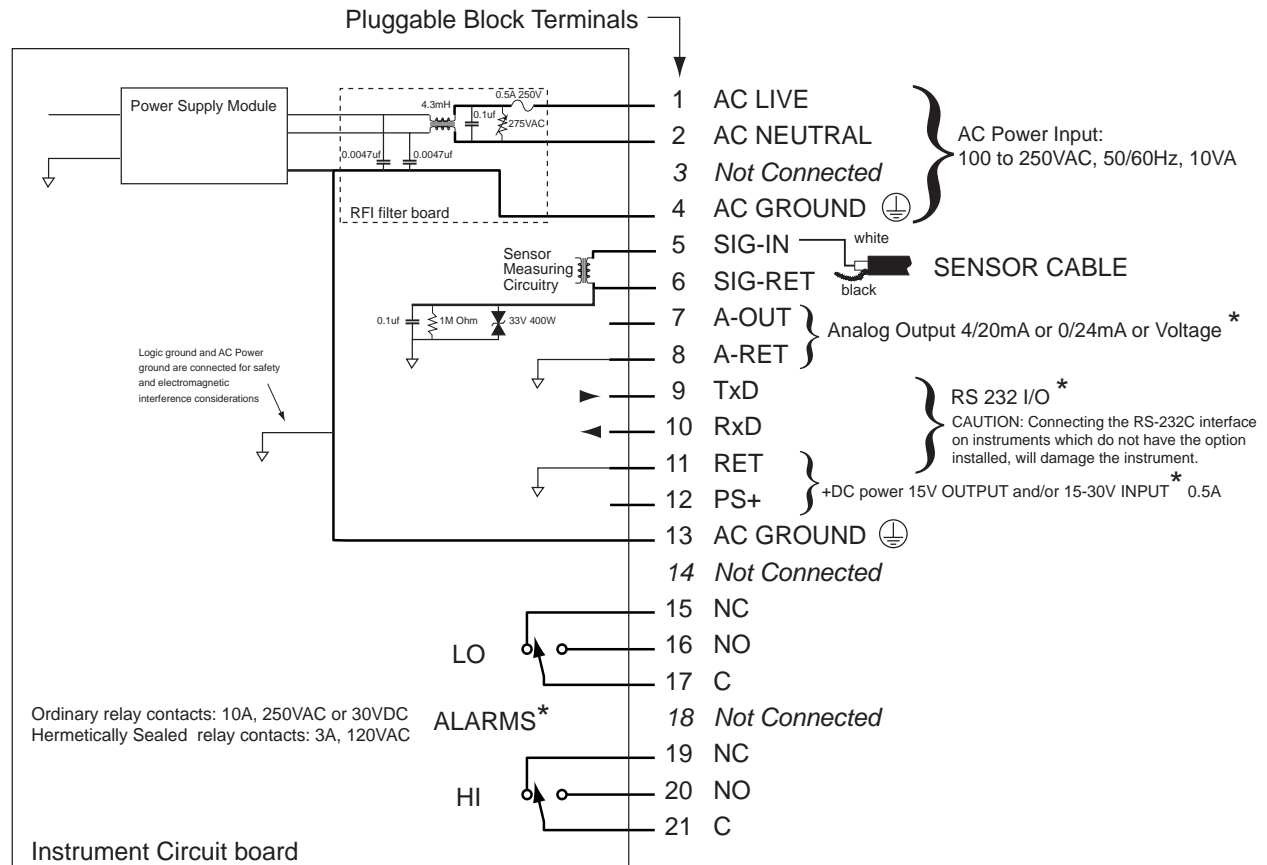

Note: * Options will function only if they are installed

Cable access to the XDT-NEMA enclosure is through three ports (refer to appendix E), which maintain the NEMA integrity:

- One 1/2" NPT conduit fitting, may be used for high or low voltage connections. This port is intended for the power and high voltage relay wiring.
- Two watertight cable grips located at the bottom of the instrument: for **low voltage wiring only** such as sensor, analog output, RS-232, or relays when used with low voltages. They accommodate cables with diameters 0.196" to 0.315". To install a cable, loosen the nut, feed the cable through the grip and tighten the nut again. Unused cable grips should be plugged to maintain the integrity of the enclosure.

3.3.2.1 Connecting Power

The XDT is typically provided to be field wired to operate from AC Mains Power of 100 to 250VAC, 50/60Hz, 10VA, the instrument has an internal 0.5A, 250V fast acting fuse. However the XDT can also be optionally ordered to operate from 15 to 30 VDC 0.5A, with an internal 0.5A

fast acting fuse. Please follow the appropriate installation procedures in the paragraphs below according to the electrical power option on your instrument. ***Do not connect to AC power without a proper ground connection.***

For Intrinsically Safe installations, first make sure that the equipment is qualified for the particular installation, it should have a label specifying the certifications and the approving agency. Then follow the appropriate control drawing as well as the instructions in the relevant paragraphs in this manual.

3.3.2.1.1 AC Mains Electrical Power Connection

The XDT is provided with a 6 foot (2 meter) internationally approved AC power cord, terminated with a connector according to the ordered option. This cable is connected to the pluggable screw terminal block; however it is provided strictly as a means of testing the instrument, *it should not be used in the final installation.* The XDT is intended as a field wired instrument permanently connected and installed according to the local, nationally recognized procedures for equipment of this type and stated power requirements. For North American installations use UL 62 and/or CSA C22.2 No 49, 18AWG cable with black, white, and green color codes. For European and other international installations use CENELEC harmonized type cable, with 0.82mm wire size or equivalent 10 amp use, with brown, light blue, and green/yellow stripe color codes. The power wiring must be connected to the pluggable screw terminals marked AC LIVE (#1), AC NEUTRAL (#2), and AC GROUND (#4). A switch or circuit breaker shall be included in the installation. It shall be in close proximity to the equipment and within easy reach of the operator. It shall be marked as the disconnecting device for the instrument. For the XDT-NEMA use the 1/2" NPT conduit fitting as the power cable access, do not use the cable grips they are for low voltage use only.

3.3.2.1.2 Low Voltage DC Powered Option - Electrical Power Connection

When an XDT is configured with the low voltage DC power option, it can be powered by applying 15 to 30 VDC 0.5A, to the PS+ (#12) and RET (#11) pluggable screw terminals. The positive supply must be connected to PS+, while the negative or ground to RET. The AC terminals must not be connected. Note that the DC supply is ground referenced to the analog output and RS-232 grounds.

3.3.2.2 Sensor Connection

The sensor input terminals are labeled "SIG-IN" (#5) for the center core of the coaxial sensor cable, and "SIG RET" (#6) for the outside braid of the cable. Factory supplied coaxial cables have a BNC connector at one end to mate to the sensor, and pigtails at the other end to be placed in the screw terminals of P1, the black pigtail is the braid and should be connected to the terminal marked "SIG RET". The coaxial cable should not exceed 17,000 pF, if the cable is changed for a longer or shorter one the instrument must be compensated for the new cable (see section 3.4.5 - 11). The instrument is properly compensated for the cable supplied from the factory. Consult your representative for obtaining the proper cable.

3.3.2.3 Wiring the Alarm Contacts

The optional alarm relay contacts are located on the terminal strip P1. The terminal strips are marked to indicate wipers and normally open and normally closed contacts, of the two indepen-

dent relays corresponding to the HI and LO alarms. The relay contacts are rated at 10A 250VAC or 30VDC, instruments for use in Division 2 Hazardous Areas have hermetically sealed relays rated at 3A 125VAC. Use wiring appropriate for the voltage and current that will be switched by the relays. Also see section 1.3 for EMI considerations. Keep in mind that the relay polarity is programmable thus wiring should be designed to provide a fail safe operation in case of power failure. See section 3.4.4.2. Also note that while viewing the dewpoint, the display will flash HI and/or LO as necessary to indicate that the corresponding alarm relay is de-energized. Specially ordered instruments may have a third alarm, refer to the supplied addendum for relay contact rating, pinouts and user interface issues.

3.3.2.4 Interfacing to the Analog Output

The optional Analog Output may be a voltage or current, depending on the ordered configuration. The Analog Output signal is provided on the P1 connector, when wiring please observe the polarity indications. The positive terminal is on pin #7 it is labeled "A-OUT" and the negative is on pin #8 it is labeled "A-RET". The ground of the Analog Output is connected to the frame (AC power) ground but it is isolated from the sensor ground, see section 3.1.1.

Instruments ordered with **Voltage** output, are configured at the factory with appropriate resistors across the current loop output such that when operated in the 0-24mA mode they produce the desired voltage.

The current loop is capable of driving loads from 0Ω to 500Ω and the user may select to operate it as 0-24mA or as 4-20mA (refer to 3.4.5-6). The output is linearly proportional to the selected engineering units. The output may be scaled such that it spans only a portion of the full range of the sensor, this feature may be useful in cases where a higher resolution output is required over a narrow dewpoint range, or vice versa. To verify or change the current loop configuration and scaling follow the instructions in the set-up mode section 3.4.5 - 6,7,8&9.

After hooking up the current loop output, it can be forced to its low, mid and high points by following the instructions in section 3.4.5 - 7. This procedure may be helpful in testing the connection and setting-up the termination equipment.

3.3.2.5 Interfacing to the RS-232 option

The optional RS-232C interface is provided on the P1 connector. The configuration is 9600 baud, Even Parity, 8 Bits, 1 Stop, all received characters are echoed. The ground of the RS-232C interface is connected to the frame (AC power) ground however it is isolated from the sensor ground, see section 3.1.1.

To connect the instrument to a Personal Computer a 3 conductor cable is required; with wires to be placed in the screw terminals of the XDT at one end, and with either a DB9 or DB25 female connector at the other end:

Signal Name	instrument P1 pin #	DB9 pin or DB25 pin	
Transmit Data	9 TXD or Tx	2	3
Receive Data	10 RXD or Rx	3	2
Signal Ground	11 GND	5	7
RTS	n.c.	7	4
CTS	n.c.	8	5
DTR	n.c.	4	20
DSR	n.c.	6	6

Note that some Personal Computer Programs may require that RTS & CTS and/or DTR & DSR are jumpered for proper operation. This jumpering may be accomplished at the DB9 or DB25 connector.

CAUTION: Connecting the RS-232C interface on instruments which do not have the option installed, will damage the instrument.

Refer to appendix K for details on the protocol used on the RS-232C interface.

3.4 Operating the Instrument

3.4.1 Starting up

The instrument is ready for use as soon as the power cabling is connected. When power is applied the instrument will initialize its program and for a moment display $\bar{E}r$, then it will enter the Operating State. If the MODE button is held pressed while the instrument is performing its power-up initialization, it will enter the Set-Up State, which allows the user to select setup variables of the instrument.

3.4.2 Display Conventions

- To display characters with the 7 segment numeric display, the following pseudo-alphanumeric are used:

Numbers:

0 1 2 3 4 5 6 7 8 9

0 1 2 3 4 5 6 7 8 9

Letters:

ABCDEF GH IJ LNOPQRS TUXYZ

R b C d E F G H I J L n o P q r S t U v Y z

Symbols:

? - .

∞ -

- The instrument will indicate whether a particular mode allows changing a parameter by showing the word “SET” in the upper left corner of the display. Be careful not to change any parameter inadvertently.
- °C/°F appear simultaneously on the right side of the display, to indicate the sensors’ attenuation in decibels.
- Values larger than ±1999 or smaller than ±0.01 are displayed in powers of $10^{\pm 3}$. As required, either a “ 10^3 ” or “ 10^{-3} ” will appear above and to the right of the displayed value, the value will be rounded off to 3½ digits. The display will show ∞ (out of range), if the number to be displayed is larger than 1,999,000. Twelve examples follow; for each the number and units desired to be displayed are shown in *italics*, depicted immediately below them is the resultant 3½ digit LCD display:

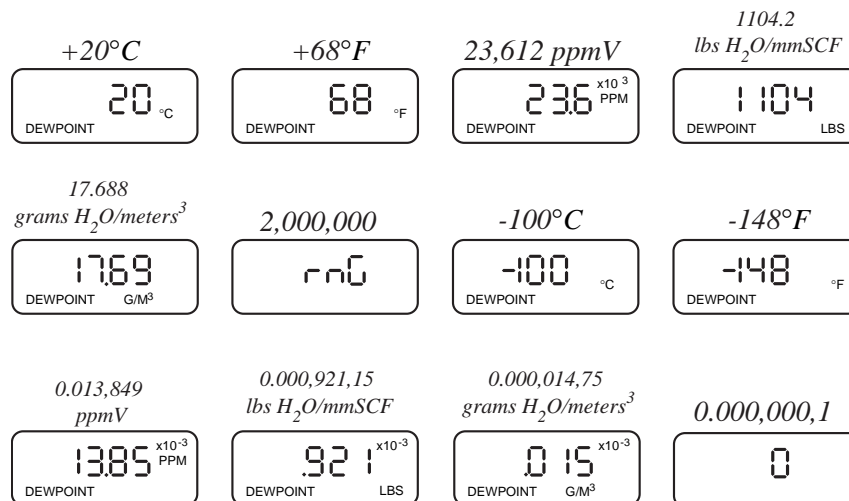

3.4.3 Push Buttons

Four push buttons provide user control of the instrument. They are designated MODE, UP, DOWN and PRESSURE CORRECT. These push buttons are vertically lined up on the upper left side of the bare circuit board, with the MODE button on top. There is also a connector provided which allows the use of external switches. The XDT-NEMA makes use of the circuit board mounted push-button switches, to access them one must open the cover of the XDT-NEMA enclosure. The XDT-PM is available in several versions:

- With a solid silk screened front face plate, which must be removed to access the circuit board switches described above.
- With a front face plate which has labeled holes placed immediately above the circuit board switches, thus the operator may push the switches without removing the face plate, by making use of a probe such as a paper clip.
- With a front plate containing four membrane switches connected to the circuit board, providing the operator with a easy to use interface.

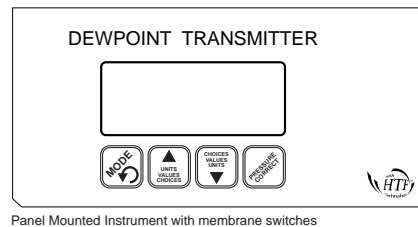
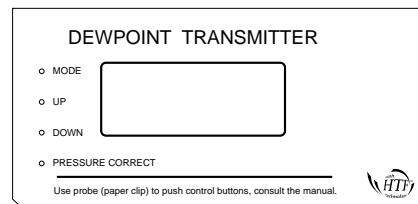
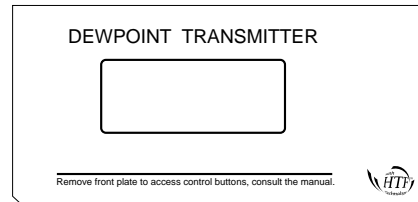
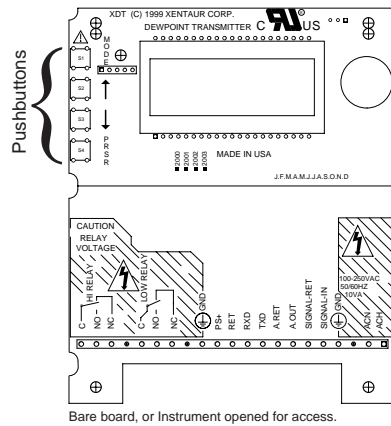

In general the MODE button navigates through the different user options “Modes”; the UP and DOWN buttons modify the units, values or choices in the selected mode. Refer to the flow diagrams in Appendix A for detailed overview of button functionality. A button may be held down for a prolonged time, for accelerated incrementing or decrementing of numeric values.

3.4.4 Operating State

Upon power up, the unit performs certain initialization tests (see table in section 3.6), and enters the ‘Operating State’, in the Viewing Dewpoint mode. Depressing the ‘MODE’ button will change modes (see appendix A) in the following order: ❶ Viewing Dewpoint ❷ Alarms ❸ Start Calibration ❹ Viewing Serial Number (back to) ❶ Viewing Dewpoint. The unit will return to Viewing Dewpoint mode if no buttons are pressed for 30 seconds, unless it is performing a calibration.

3.4.4.1 Viewing Dewpoint Mode

When the instrument is powered on, it defaults to this mode. In addition, if the user navigates to any other mode and ceases pressing the buttons for 30 seconds, then the instrument reverts to this mode. In this mode the user can view the dewpoint, this is indicated by the presence of the ‘DEW-POINT’ legend on the lower left of the display. The available engineering units in which to view

the moisture content are °C, °F, PPM, LBS and G/M³; the UP and DOWN buttons scroll back and forth through these units in respective order. The °C and °F are dewpoint readings. The PPM is parts per million by volume computed at the sensor pressure (more about pressure later). The LBS and G/M³ are density measurements, pounds of water per million standard cubic feet and grams of water per standard cubic meters, respectively, both in Natural Gas, they are computed according to data derived by IGT Research Bulletin 8, taking into account sensor pressure.

Note that the analog output is linear to the selected engineering units, therefore be mindful that when certain units are selected, the analog output may change even though the measured dewpoint is stable. The instrument, when locked, will allow changing the engineering units only temporarily and will keep the analog output linear to the original units. This feature is useful because users can view the measurement in units other than the ones chosen for normal operation, without disturbing the equipment connected to the output. If they forget to switch back to the original units, the instrument will timeout and switch back - during this whole time the analog output will operate undisturbed with the original units.

If the user desires to permanently change the units, then the instrument must be first unlocked (see section 3.4.5-10), the units changed; it is recommended that the instrument is then locked.

The PSI legend flashes at the bottom of the display, when there is pressure correction in the computation of the displayed values. A short press of the 'pressure correct' button toggles the unit in and out of pressure correct mode. When there is no pressure correction applied, the PSI legend does not appear.

Sensor Pressure is used in the context that this is the pressure inside the sample cell when performing the measurement, i.e. it is the operating pressure of the sensor.

Gas Pressure is used in the context that this is the pressure at which the dewpoint is to be calculated.

Pressure Correction is used in the context that the values displayed signify the moisture content at some pressure (we refer to this as the 'Gas Pressure') different from the pressure at the sensor.

Note that PPM, LBS and G/M³ readings are by definition unaffected by pressure correction because only the pressure at the sensor affects their value. While °C and °F are affected by pressure correction by reporting what the dewpoint would be at the Gas Pressure when the dewpoint is what is measured at the pressure at the sensor. However, this also implies that whether pressure correction is applied or not the PPM, LBS and G/M³ readings are affected by the setting of the sensor pressure.

A long press of the Pressure Correct button, while in the pressure correct mode (flashing PSI legend), changes the unit to the View/Set Sensor Pressure sub-state. The display has the 'SET' and 'PSI' legends on, and alternately shows $\Sigma \bar{P}$ and the currently set value for the sensor pressure. The up and down buttons allow the user to modify the sensor pressure, while a short press of the pressure correct button toggles the Sensor Pressure setting between whatever value is on the display and 14.7 psi ---- this is a quick way to go back to atmospheric settings. A long press of the pressure correct button changes the unit back to the Viewing Dewpoint Mode. Pressing the 'Mode' button changes the unit to the View/Set Gas Pressure sub-state. The display has the 'SET' and 'PSI' legends on, and alternately shows $\bar{P} \Sigma$ and the currently set value for the gas pressure. The up, down and pressure correct buttons operate in the same manner as in the Sensor Pressure sub-state. Pressing the 'Mode' button changes the unit back to View/Set Sensor Pressure sub-state, and so forth.

- Notes:
1. Instruments are shipped from the factory in the locked mode and must be unlocked before this procedure can take place (see section 4.3 #7 to unlock).
 2. The factory default settings are: 14.7psi for both sensor and gas pressure and pressure correction disabled.
 3. When Pressure correction is disabled all dewpoints are computed by assuming that both Sensor and Gas Pressures are 14.7psi.
 4. Pressure correction will effect the analog output but not the alarm relay trip-points. The analog output will track the pressure corrected dewpoint, the relays will trip on the uncorrected dewpoints.

3.4.4.2 Alarms

There are two independent optional alarms, they are named HI and LO alarms. Each alarm can activate a single pole double throw relay rated at 10A 250VAC or 30VDC per contact. Instruments for use in Division 2 Hazardous Areas have hermetically sealed relays rated at 3A 125VAC. Specially ordered instruments may have a third alarm, refer to the supplied addendum for relay contact rating, pinouts and user interface issues. The alarms can be set with a trip-point at any dewpoint within the range of the selected sensor. There is also a selectable hysteresis (with a minimum value of $\pm 0.5^{\circ}\text{C}$ to prevent relay chatter) which allows driving systems such as regenerative dryer purge valves in “dewpoint demand mode”. The polarity of the alarm is also selectable, thus one may choose whether the relay energizes above or below the trip point, to allow fail safe design in case of XDT power loss, or in case of any other errors or failures which will cause the relays to de-energize.

When an alarm relay is deenergized the corresponding HI and/or LO indicator flashes on the display while viewing the dewpoint.

The behavior of the alarm when a sensor failure (e.g. open or short) is detected is also programmable. The options upon sensor failure are:

1. Fail High - put the alarm in a state as if the dewpoint is high, e.g. $\text{R.}\bar{\Xi}.\text{H}$
2. Fail Low - put the alarm in a state as if the dewpoint is low, e.g. $\text{R.}\bar{\Xi}.\text{L}$
3. Fail Flashing - Energize/Deenergize the relay alternating once every 2 seconds, e.g. $\text{R.}\bar{\Xi}.\text{F}$
4. No Special Handling - if sensor is open the alarm is in a low dewpoint state; if the sensor is shorted, the alarm is in a high dewpoint state, e.g. $\text{R.}\bar{\Xi}.\text{r}$

Setting or checking the present setup of the alarms is illustrated with the following example:

EXAMPLE: - Set the ‘HI’ alarm to de-energize the relay when the dewpoint is wetter than -75°C with minimal hysteresis ($\pm 0.5^{\circ}\text{C}$), and faults such as sensor failure cause relays to react as if there is high dewpoint i.e. if sensor cable breaks the relay de-energizes.

When following these instructions, it may be helpful to refer to Appendix A.

1. Make sure that the instrument is not in the locked mode.
2. While in the viewing ‘Dewpoint Mode’ push the UP or DOWN buttons until the $^{\circ}\text{C}$ indicator appears.
3. Push the MODE button until the display shows:

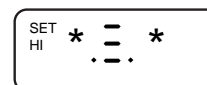

the asterisks ‘*’ take the place of characters that may appear depending on previous set-

tings; the 'SET' indicator means that changes can be made; the 'HI' indicator means that we are changing the HI Alarm, (alarm #1).

Note that if the instrument does not have the alarm options installed this MODE (User Option) will not appear.

4. Push the UP or DOWN buttons until the display shows:

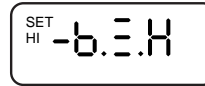

the -6 means energize below or de-energize above set dewpoint, the H means faults look like high dewpoint. If the display shows L0C, the alarm changes are locked out, repeat step 1.

5. Push the MODE button. The display will show:

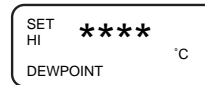

the 'DEWPOINT' indicator means that we are changing the alarm trigger dewpoint

6. Push the UP or DOWN buttons until the display shows:



7. Push the MODE button. The display will show:

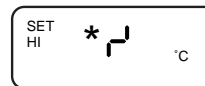

the r indicates that we are changing the hysteresis of the alarm.

8. Push the UP or DOWN buttons until the display shows:

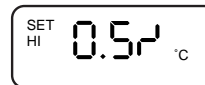

9. Push the MODE button until the instrument goes to the dewpoint display mode.

10. If it is desired to prevent inadvertent alarm settings changes by unauthorized people, activate the Lockout.

The Alarm Relays switch on non-pressure corrected dewpoints. Thus enabling or disabling the pressure correction will not effect the relays.

The instrument will retain the alarm settings even if the power is turned off.

3.4.4.3 Start Calibration

The instrument is calibrated at the factory with the sensor it is shipped with and does not need to be re-calibrated prior to installation.

The calibration mode allows two different types of calibrations.

- SpanCheck™: an Automatic Calibration using the sensor's ability to saturate, thus no additional materials or equipment are required, this calibration is most useful after long periods of usage and a suspicion of performance degradation.
- Single point calibration: the calibration curve derived from SpanCheck is modified at a single point using the output of the sensor as it is exposed to a gas with a known dewpoint. This calibration is most useful when the sensor is exposed to hygroscopic substances which constantly alter the equilibrium between the sensor and the gas being measured (e.g. glycol), or when the sensor is exposed to corrosive gasses and may drift. If the known gas is chosen to be at a dew-

point at or close to the critical measurement point of the process then an extreme accuracy of the process may be maintained even in the most harsh of applications.

In general we recommend to perform SpanCheck in 12 month intervals (*not more often*), and single point calibration as often as practically possible. When it is time to perform both calibrations, first disable the single point calibration, then perform the SpanCheck calibration, then perform the single point calibration. This procedure is not necessary but it is preferred when both calibration are performed.

3.4.4.3.1 SpanCheck™ Mode

The instrument is calibrated at the factory with the sensor it is shipped with and does not need to be re-calibrated prior to installation.

Instrument calibration is recommended in approximately 12 month intervals, and the XTR65W sensor should be re-calibrated after prolonged exposure to liquid water. Simply follow steps 1 - 7 of the procedure below, removing the sensor from the sample gas stream. To avoid injury, make sure the gas stream is depressurized before removing the sensor.

It is recommended to keep the sensor exposure to room air as short as possible, in order to avoid super saturation of the sensor. While super saturation is not damaging to the sensor, it will prolong the initial dry-down time after you install the sensor in the sample stream. Therefore, remove the sensor from the sample stream or packaging container only after you are ready to proceed with the calibration procedure and install the sensor in the sample stream immediately after the calibration procedure is completed. If you are not ready to use the sensor right away after calibration, put the sensor back in the shipping container for dry storage.

The instrument must be calibrated with the sensor it will be used with. The calibration procedure takes advantage of the sensor's ability to saturate (refer to Appendix F) and is executed by the instrument computer, by performing the following steps:

If a single point calibration is in effect with a reference dewpoint below -70°C, it should be disabled (see next section) before performing SpanCheck calibration.

1. If the instrument is locked and a calibration is attempted; it will display $L\alpha C$ and will not perform the calibration. To unlock the instrument consult section 3.4.5.-10
2. Push the MODE key a few times until the display shows CRL .
3. Press the UP button. The display will show CnF , prompting you to confirm that you want to start the calibration procedure. You can abort the calibration procedure by pressing the MODE key.
4. Remove the sensor from its packaging container or sample stream, so that the porous metal filter is visible and the sensor is exposed to in-hand micro-climate (refer to explanation below). Close the packaging container as soon as you have removed the sensor to avoid degradation of the desiccant inside the container. You may want to re-use the container at a later date.
5. Expose the sensor to in-hand micro-climate, and push the UP button again to confirm that you want to start the calibration procedure. The display will flash Rn for 60 seconds, while the sensor is saturating. Make sure you keep the sensor exposed to in-hand micro-climate until the display shows $En\alpha$.
6. After 60 seconds, the display will flash the selected sensor type (see *Selecting a sensor type* 3.4.5.-2) and then the instrument will calculate the slope and offset of the sensor curve while

displaying the calculations and then will display E_{nd} for a few seconds, after which the instrument will automatically go into measuring mode. The sensor calibration is completed. (The display may flash S_{at} , indicating that the sensor has super-saturated. As soon as the sensor is exposed to an atmosphere with a dewpoint lower than the saturation dewpoint, the display will indicate the dewpoint measured by the sensor.) The display may show alternating S_{En} and L_{o} as an indication that the measured capacitance is too low to be from a saturated sensor, in this case make sure that the sensor is properly plugged in, and repeat the calibration procedure.

7. Install the sensor in the sample cell or adapter fitting or put it back into the packaging container for later use.

The instrument will retain the calibration even if the power is turned off.

Under certain conditions, an over (super) saturated sensor may need to be completely dried out before a calibration is performed. Symptoms of these conditions are a sensor that will not go through the SpanCheck™ function to the E_{nd} display, or a sensor that will not dry down after calibration. To dry, install sensor in either a known dry gas stream i.e. instrument quality air or dry nitrogen, or place sensor in a dry can or bottle of desiccant and seal the container from outside air (the shipping container is designed for this purpose). After a minimum dry out period of 24 hours, proceed with the calibration procedure of your choice.

SpanCheck™ calibrates sensors by using micro climates. Please contact your representative if you have any questions about how to create such micro climates.

A perfectly acceptable and accurate for calibration micro-climate may be created for the XTR100 and XTR65 sensors by cupping the sensor in the palm of one's hand during the SpanCheck™ procedure. Remember that the micro-climate does not have to be accurate, it just has to be higher than the designed saturation level. The dewpoint of the micro-climate within the fingers is usually higher than the dewpoint of the room air and probably well above the +20°C upper range of the sensor. On a dry day, one may need to exhale in the hand before cupping the sensor to guarantee a high dewpoint. The sensor should be warmed up close to body temperature before performing this procedure. Care must be taken that the sensor temperature is not below the temperature of the hand, as in such case condensation could occur and super saturate the sensor. For the same reason, avoid exhaling directly onto the sensor.

3.4.4.3.2 Single Point Self Calibration, manual or scheduled

The instrument is calibrated at the factory with the sensor it is shipped with and does not need to be re-calibrated prior to installation.

Single point calibrations should be performed whenever the measurement is in question, or on a scheduled basis depending on the application. Consult with your representative to establish criteria for specific applications.

The single point calibration is performed on the premise that the sensor is exposed to a gas with a known dewpoint for a time sufficient to equilibrate. Then the sensor output is measured, and the calibration curve is adjusted to provide measurement computations which correspond to the known dewpoint. Measurements over the full sensor range are linearly adjusted to this known point.

The single point calibration provided by this instrument may be performed manually, or (when a sample system is ordered equipped with an electrically actuated switchover valve) unattended on

a repetitive timer scheduled basis. The user interface for both is the same, with additional steps for interval setting and automatic stabilization time outs for the instrument with the electrically actuated valve.

Manual Single Point Self Calibration procedure for instruments without electrically actuated switchover valve:

- Refer to the unshaded area of the flow diagram on the second page of Appendix A.
- Expose the sensor to a known dewpoint
- Wait at least 15 minutes for the sample system to be stable, if the known gas is of a low dewpoint the waiting time may have to be increased - specially if the sensor was wet before the procedure is initiated. Consult with your representative to determine sufficient waiting time for your application.
- Make sure the instrument is unlocked.
- Press the MODE button a few times until the display shows CAL.
- Press the DOWN button to select the Self Calibration mode. The display will show SELF/CAL
- Press the UP button to confirm entry into the Self Calibration mode. The display will show the reference dewpoint which has been previously programmed into the instrument, the SET and DEWPOINT legends will also appear. Use the UP and DOWN buttons to modify this dewpoint to match the dewpoint of the known gas to which the sensor is exposed.
- Press the MODE button, the display will show BEG/SET., prompting to begin the Self Calibration.

If the MODE button is pressed the calibration will be canceled and instrument will go to the Serial Number mode. All setup will still be in effect, e.i. newly entered reference dewpoint will remain in the instrument's memory.

If the DOWN button is pressed the Self Calibration corrections will be disabled; any Self Calibrations performed previously will not be used in correcting the computed dewpoint of the instrument.

- Press the UP button to initiate the Self Calibration. the display will show CONF/SCP, prompting for a confirmation that the Self Calibration should be performed.
If the DOWN or Pressure Correct buttons are pressed the Self Calibration will be aborted.
- Press the UP button to confirm the Self Calibration. The display will show alternately SET/566 /-41.5, indicating that Self Cal Stabilization is being checked and currently the instrument is measuring -41.5°C. When the measured dewpoint is stable within 0.5°C for 3 minutes the instrument will record the new single point self calibration values and finish by going to the display dewpoint mode. Note that the program will spend at least 3 minutes on this stage of the calibration.
- The sensor may now be exposed to the sample gas and the instrument will display the measurement using the newly acquired calibration values.

Scheduled Timer Activated Single Point Self Calibration procedure for instruments with electrically actuated switchover valve and on-board battery backed real-time clock:

- Make sure that your sample system is properly connected according to the sample system instructions. When the time-outs and stabilization times are summed from the calibration stages below, it can be determined that the calibration reference gas will be used for at least 18 minutes, the user should make sure that there is sufficient amount of gas available. If the reference gas is provided from a compressed gas bottle, make sure that there is sufficient pressure

in the bottle, for some bottles there is a cut-off pressure below which the dewpoint is not guaranteed. Make a note of the exact dewpoint of the reference gas as it will be required in the next steps.

- Refer to the unshaded area of the flow diagram on the second page of Appendix A.
- Make sure the instrument is unlocked.
- Press the MODE button a few times until the display shows CAL.
- Press the DOWN button to select the Self Calibration mode. The display will show SLF/CAL.
- Press the UP button to confirm entry into the Self Calibration mode. The display will show the reference dewpoint which has been previously programmed into the instrument, the SET and DEWPOINT legends will also appear. Use the UP and DOWN buttons to modify this dewpoint to match the dewpoint of the reference gas.
- Press the MODE button, the display will alternately show 720 / Hrs / Int., indicating that the calibrations are scheduled at 720 hours interval. Use the UP and DOWN buttons to change the interval time to whatever is determined to be most effective for your application, consult with your representative if you are in doubt. An interval of 0 Hrs (appears as a blank on the display), disables any further scheduled unattended calibrations, however the instrument will continue to make use of calibration values acquired previously or manually in the future. Pressing the Pressure Correct button will cause the instrument to momentarily display 150 / Hrs / LEFT, indicating that there are 150 hours left until the next scheduled calibration is performed. This is a useful indication in cases where it is not known when the next calibration will be performed.
- Press the MODE button, the display will show BEG/5., prompting to begin the Self Calibration.
 - If the MODE button is pressed the calibration procedure will be canceled and instrument will go to the Serial Number mode. All setup will still be in effect, e.i. newly entered reference dewpoints, the scheduled interval time etc. will still be used by the system.
 - If the DOWN button is pressed the Self Calibration corrections will be disabled; any Self Calibrations performed previously will not be used in correcting the computed dewpoint of the instrument. However newly entered reference dewpoints and the scheduled interval time will still be in effect; thus when the time elapses a Self Calibration will be performed and its values will be used in correcting the computed dewpoint from that time on.
- Press the UP button to initiate the Self Calibration. the display will show CONF/SCP, prompting for a confirmation that the Self Calibration should be performed. If the DOWN or Pressure Correct buttons are pressed the Self Calibration will be aborted, however everything set until now will remain in effect.
- Press the UP button to confirm the Self Calibration. The display will show SLF/CAL/-41.5 indicating that self calibration has started and it is measuring a dewpoint of -41.5°C, (this is also the entry place into the procedure when the scheduled time elapses). Now the instrument will “freeze” the analog output and the alarm relays so that they are not influenced by the reference gas dewpoint. Then the instrument will activate the electrically actuated switchover valve and thus introduce the reference gas to the sensor, and initiate a 15 minute time out allowing the system to reach equilibrium. (Since the program will perform the above when the scheduled interval elapses, this step may be occurring in an unattended mode, thus the reference gas bottle and regulator must be left in the open positions, the switchover valve will keep them from being exhausted.)
- After the 15 minute stabilization time out, the display will show alternately 5./5.5b /-41.5,

indicating that Self Cal Stabilization is being checked and currently the instrument is measuring -41.5°C . When the measured dewpoint is stable within 0.5°C for 3 minutes the instrument will record the new single point self calibration values. Note that the program will spend at least 3 minutes on this stage of the calibration.

- The electrically actuated switchover valve will be deactivated thus introducing the sample gas to the sensor, and the dewpoint will be monitored for stability. The display will show $5.5 / \text{Flr} / -42$ indicating that self calibration has finished and it is measuring a dewpoint of -42°C . When the measured dewpoint is stable within 0.5°C for 3 minutes the instrument will “unfreeze” the analog output and relays and go to the display dewpoint mode.
- The instrument will display the measurement using the newly acquired calibration values.

The instrument computes the dewpoint from the measured capacitance of the sensor. The sequence of computations is as follows:

- The capacitance is converted to percent of full scale (-100°C to $+20^{\circ}\text{C}$ dp), using the low dB, low dew, and saturated dB when performing SpanCheck values.
- Cal Adj is applied to correct the mid point of the curve.
- If enabled, the multi-point calibration table is applied to further correct the transfer function.
- If enabled, the single point calibration is applied to fine tune the transfer function.
- The corrected percent of full scale is converted to dewpoint.

3.4.4.4 Viewing Serial Number Mode

In this mode the user can view the instrument serial number. The display shows the serial number by alternately displaying $\Xi 5n$ and the number. If the number is larger than 1999 then it is displayed in 2 parts, first part is the thousands signified by the $\times 10^3$ legend in the upper right corner of the display and the second part is the units. For example serial number 12345 will be shown as:

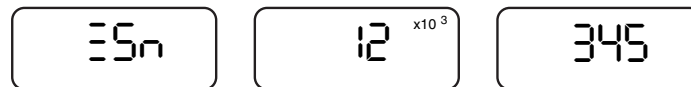

Pressing the UP and DOWN buttons simultaneously resets the instrument, this is useful in installations where power can not be turned on and off easily. Pressing the Pressure Correct button will cause the instrument to enter the setup state.

Pressing the MODE button, returns the unit to the Viewing Dewpoint Mode.

3.4.5 SetUp State

To enter the Setup State power-up the unit (or reset it from the serial number Mode), and hold the MODE key pressed while the unit is initializing. Refer to Appendix B for a flow diagram of the SetUp State.

The setup state provides eleven capabilities, each one controlled from its own mode. Depressing the MODE button navigates through the modes in the following order: ❶ Select Alternate Display Units ❷ Select Sensor Type ❸ Set Measured Attenuation of Sensor at a Low Dewpoint ❹ Set the Low Dewpoint at which the Attenuation was measured ❺ Set the Calibration Mid-range Adjust ❻ Analog Output select 4/20mA or 0/24mA ❼ Perform a Test and Verification of the Analog Output ❽ Set dewpoint corresponding to low end of Analog Output ❾ Set dewpoint corresponding to

high end of Analog Output **10** Lock/Unlock the instrument **1 1** Sensor Cable Compensation (back to) **1**.

These eleven functions are explained in their respective sections which follow. Note that modes 6,7,8&9 will appear only on instruments with the analog output option. *Changes can be made only to an unlocked instrument*, the changes are stored (when the MODE button is pressed) and retained even if the instrument power is turned off.

1. **Display of alternate units:** In this mode, a second engineering unit can be chosen to be displayed alternating with the engineering unit selected in the operating state, for example, a dewpoint can be alternately shown in °C and in PPM.

CAUTION:

2), 3), 4) and 5) are set at the factory and need only be modified when a sensor is changed.

2. **Selecting the sensor type:** In this mode the user can select the software matching the type of sensor installed in the instrument:
 - ☐☐ : XTR-100 (-100°C to +20°C);
 - ☐☐☐ : XTR-65 (-65°C to +20°C);
 - ☐☐☐☐ : show impedance of any sensor, disable Open and Short error messages.

3&4 Adjusting low end sensor attenuation and dewpoint: These modes are used to enter a data pair representing a low dewpoint and the sensor attenuation measured at this low dewpoint. (see Sensor Theory of Operation appendix F). This data pair should not be modified unless the sensor is replaced (refer to procedures for replacing a sensor in appendix L). The sensor shipping container is labeled with the proper values.

5. **Calibration Adjustment:** In this mode the user can enter a sensor specific Adjustment Value to improve the instruments' accuracy in the range of -50°C to -10°C, this adjustment has very little or no effect outside this range. The Calibration Adjustment Value is printed on the shipping container supplied with the sensor, or may be derived if the sensor can be exposed to a known reference.

Deriving an Adjustment Value: If the adjustment value for your sensor is not known, contact your representative and follow the instructions below for entering known values. If the value is not available, then it may be derived using a manual method, provided that a moisture calibration facility is available.

The calibration must be done in the range of -25°C to -20°C (attempting to calibrate outside this range may cause inaccuracies), the dewpoint must be kept stable during calibration and it must be measured accurately by a reference instrument such as a chilled mirror. One must also note the state of pressure compensation and turn it on or off as applicable to the reference.

The necessary steps are described below (also refer to the Set-Up State flow diagram in Appendix B):

- a. Make sure that the low attenuation and low dewpoint are correctly entered for this sensor.
- b. SpanCheck™ the sensor.
- c. Dry-down the sensor for at least 12 hrs.
- d. Expose the sensor to the known dewpoint (-25°C to -20°C), for a sufficient time (at least 30 min.)
- e. Go to the $\overline{\text{RL}}/\overline{\text{RD}}$ mode and press the UP button, the display will show the current value, in the range of -2.50 to +2.50 followed by blinking horizontal lines.
- f. Observe the display, if the buttons are not being pressed; the display will every few seconds show for a short duration the dewpoint as being computed at the moment (utilizing the current

cal-adjust value in the computation).

g. Use the UP or DOWN buttons to modify the cal-adjust value and observe the alternately displayed dewpoint. Perform this adjustment until the dewpoint matches the value shown by the reference instrument.

h. Press the MODE button to go to the next mode, this will save the new cal-adjust value, and it will be retained even if power is turned off.

Entering a known Adjustment Value: If the sensor is being replaced an adjustment value should be supplied with the sensor, to enter it into the instrument:

a. Go to the $\overline{\text{CAL}}/\overline{\text{ADJ}}$ mode and press the UP button, the display will show the current value, in the range of -2.50 to +2.50 followed by blinking horizontal lines, ignore the alternately displayed dewpoint.

b. Use the UP or DOWN buttons to modify the cal-adjust value as necessary.

c. Press the MODE button to go to the next mode, this will save the new cal-adjust value, and it will be retained even if power is turned off.

6. **Analog Output Span selection 4/20 mA or 0/24 mA:** By pushing the UP or DOWN buttons, the user may select the desired span of the analog output.

7. **Testing the analog output:** By pushing the UP, DOWN, or Pressure Correct buttons, the user forces the analog output to its high, low and mid-range values, respectively. This facilitates the hook-up and testing of the user's monitoring equipment.

8&9**Output range setting:** These modes are used to set dewpoints corresponding to the low and/or high end of the Analog Output. The factory default values are: low end at -100°C, and high end at +20°C. For detailed discussion of the necessary considerations when choosing the analog output range, refer to appendix J.

10. **Lock/Unlock the instrument** with *optional SECURED* password protection

The Lock/Unlock feature of the instrument allows the owner to block access to parameter settings, protecting the instrument from unauthorized or inadvertent changes. Attempting to change settings while the instrument is locked will display $\overline{\text{LoC}}$ and beep.

- When in the Lock/Unlock Mode and the instrument is locked the display will show “ $\overline{\text{SET LoC}}$ ”. The instrument may be unlocked by pressing the “UP” button. If “ $\overline{\text{SEC}}$ ” is displayed, refer to the Secured Password Protection section below.
- When the instrument is unlocked the display will show “ $\overline{\text{SET Hi/LoC}}$ ”. The slash (/) denotes that the display is alternately showing $\overline{\text{Hi}}$ and $\overline{\text{LoC}}$, this is necessitated by the 3.5 digit limitation of the display. Pressing the “DOWN” button will lock the instrument.
- Pressing and holding either the “UP” or “DOWN” buttons, will save the locked or unlocked setting depending on the button, and reset the instrument. This feature is useful in situations where it is difficult or undesirable to power off the instrument.
- Pressing the MODE button will navigate to the Sensor Cable Compensation mode.

Secured Password Protection

Instruments may be specially ordered with password protection. To unlock the instrument the user must supply a password, which consists of a number in the range of -1999 to 1999 (approximately 4000 unique passwords). Instruments that require a password, will display “ $\overline{\text{SEC}}$ ” (secured) when the user attempts to unlock by pressing the “UP” button. After approximately 1 to 2 seconds the instrument will display “ $\overline{\text{000}}$ ”, with the first digit flashing. The flashing denotes the cursor position, which means that the “UP” and “DOWN” buttons will increment or decrement this digit

respectively. Pressing the “MODE” button will move the cursor (flashing digit) to the right. Pressing and holding the “MODE” button will signal the instrument to read the password and if correct to unlock the instrument. As discussed above an unlocked instrument will display “SET UP/LO”. The user may enter the assigned password by pressing the UP, DOWN and MODE buttons. The first digit is unique in that it consists of 1½ digits in the range of -19 to 19, this allows entering the full range of assignable numbers.

An example is used to illustrate the unlocking of a password-protected instrument. Suppose the password is 1234. After an attempt to unlock, the user will see “SEC” followed by “000”, with the first 0 flashing. Pressing the “UP” button twelve times will display “ 1200” (overshooting a number can be corrected by reversing the use of the UP and DOWN keys), with the “ 12” flashing. Pressing the “MODE” button will flash the next “0”. Pressing the “UP” button three times will display “ 1230”. Pressing the “MODE” button will flash the last “0”. Pressing the “UP” button four times will display “ 1234”. Pressing and holding the “MODE” button, will display “SET UP/LO”, indicating that the instrument is now unlocked. It may be locked without the password, same as any other instrument.

Note: To avoid unauthorized changes, it is imperative that instrument is returned into the locked mode.

11. Sensor Cable Compensation: As noted in other paragraphs this instrument measures the impedance of the sensor (in the form of attenuation in decibels) from which it computes the dewpoint. At very low dewpoints the sensor capacitance is small enough to be in the same order of magnitude as a long coaxial cable. Thus the measurement circuit must be compensated for the impedance of the sensor cable. **Instruments which are delivered with a cable are already compensated at the factory and should not be compensated again**, however if a new cable is connected, the following procedure should be used for compensation (also refer to the Set-Up State flow diagram in Appendix A):

- a. Disconnect the sensor from the cable by unplugging the BNC connector, keep the cable connected to the instrument.
- b. Prepare a means by which the BNC connector at the end of the cable could be reliably shorted (using a jumper clip etc.), do not attempt to short at the instrument screw terminals as this approach will not account for the cable resistance.
- c. Go to the CONF/CLBL/OPN (Confirm Cable Open) mode.
- d. Leave the BNC connector open and press the UP key. The instrument will show OPN and beep for a few seconds. Then it will show CONF/CLBL/SHR (Confirm Cable Short).
- e. Short the BNC connector and press the UP key, the unit will show SHR and beep for a few seconds. Then it will show CONF/CLBL/OPN again.
- f. Leave the BNC connector open again and press the UP button. The instrument will show OPN and beep for a few seconds. Then it will show END

The compensation data will be retained even if power is turned off.

3.5 Resettable Audio-Visual Alarm Option (NFPA compliant)

When the instrument is ordered with an Audio-Visual Alarm option, it is provided in the XDT-NEMA enclosure, outfitted with two front panel momentary push buttons in NEMA sealed rubber boots. The instrument complies with the recommendations of NFPA 99, 1996 edition.

- The alarm set point is programmed on a third alarm, hence the HI and LO alarm relays are free to be used for additional purposes. The third alarm is properly configured to 39°F at the factory, but when necessary may be modified by the user. Refer to the notes following HI & LO Alarms in the *Flow Diagram of Operating State User Interface* in appendix A.
- The visual indicator is the display backlight. When there is no alarm condition the LCD display is not backlit but can still be easily and clearly read (in an extremely dark room the backlight may be momentarily turned on by pressing the TEST button). However as long as an alarm condition exists the LCD will be backlit in red. This lit-up front window of the instrument is the visual indicator.
- This configuration is also equipped with a NEMA sealed audio indicator (>80dB @ 3ft) mounted in the instrument enclosure. It is activated when an alarm condition occurs, it may be disabled by momentarily pressing the RESET button on the front panel. When the alarm condition ceases to exist, the audio indicator is automatically re-enabled, ready to be activated on next alarm condition.
- A momentary TEST button on the front panel allows testing both the visual and audible indicators.

3.6 Troubleshooting the Instrument

This instrument performs diagnostic tests on power up as well as once every two minutes. The table that follows, depicts all possible error/unexpected messages that may be displayed on the instrument. For each message the table has explanations for the reason, and if necessary a suggested action to remedy it.

The instrument contains a fuse which may open if the instrument is subjected to voltages exceeding the specifications. Under these circumstances the unit display will be blank and the instrument will not draw any current when powered up. The user may replace the fuse with a comparable 0.5A, 250V fast acting fuse, to locate the fuse refer to the XDT mechanical drawing in Appendix E.

DISPLAY	EXPLANATION		REQUIRED ACTION	
LO Err	PROM check sum failed.	power on tests	cycle power if problem persists, return to your representative for service.	
HI Err	RAM write/read test failed.			
% Err	Unidentified power-up failure.			
C.S.F./	EEPROM Check Sum <i>Failed</i> .			
Err/Rd	<i>A/D</i> converter failure.	system tests once per 2 min.	make sure that the unit is at a temperature of -10°C to +50°C.	
Err/rEF	<i>Reference</i> voltage for A/D out of spec.			
Lo/bAt	<i>Low supply</i> voltage.			
LO rnt/TEMP	Instrument <i>low temperature range</i> has been exceeded.			
HI rnt/TEMP	Instrument <i>high temperature range</i> has been exceeded.	dewpoint display tests	see table in sensor troubleshooting section 2.5	
oPn/	Sensor circuit is <i>open</i> .			
SAt/	Sensor is <i>saturated</i> .			
SHr/	Sensor circuit is <i>shorted</i> .			
...	Trying to calculate dewpoint for undefined sensor.		select sensor and recalibrate.	
db	Trying to calibrate an undefined sensor.	calibration tests	see calibration instructions.	
SEn/2Lo	<i>Sensor</i> reading is ' <i>too</i> ' low to be from a saturated sensor, thus can not be calibrated			
2Lo	While Compensating for cable length, the measurement did not correspond to the expected open or short values.	cable tests	Check the means of opening & shorting the sensor cable. see section 3.4.5 - 11	
2Hi				
Err/EEP	<i>EEPROM</i> write cycle not completed.	miscellaneous	if this persists, return for service.	
LoC	Attempting to modify a <i>locked</i> unit.		unlock unit, see set-up state 3.4.5.-10.	
SEC	Attempting to unlock a <i>secured</i> unit.		See section 3.4.4.2 Setting the Alarms.	
HI (flashing while viewing DEWPOINT)	The HI Alarm (alarm #1) relay is deenergized.			
LO (flashing while viewing DEWPOINT)	The LO Alarm (alarm #2) relay is deenergized.			
R.o./oPn	The Analog Output 'sees' an open circuit		check the cables connecting the analog output, make sure the terminating impedance is less that 500Ω.	
PSI flashing when displaying dewpoint	Pressure correction is enabled, the dewpoint is computed using programmed pressures		refer to section 3.4.4.1	
-70°C (-94°F) with flashing DEWPOINT	An XTR-65 sensor is measuring less than -70°C or -94°F D.P.		check instrument upgrade to XTR-100 sensor	
units flash and revert back to original state	The user changed the units of measure when the analyzer is locked the software keeps analog output with original inits		unlock analyzer, change units, lock analyzer (see section 3.4.4.1)	
rnt	number can not be displayed in 3½ digits			
ΞEn	Turn on message, <i>Xentaur</i> (Greek Ξ=X)			
display is dark	No power to instrument			check power to instrument, check fuse

Legend: denotes a beeping accompaniment to the message.
/ denotes alternately flashing messages.

3.7 Maintenance

The XDT-PM and XDT-NEMA instrument enclosures may be cleaned when necessary using a damp (moist) cloth. The XDT-OEM bare circuit board may be cleaned by blowing air across the circuit board. The sensor should not be cleaned as it may be damaged.

Spare parts may be ordered through your representative.

Glossary

0/24 mA	range of current for the current loop (0mA=minimum reading, 24mA=maximum reading)
4/20 mA	range of current for the current loop (4mA=minimum reading, 20mA=maximum reading) - preferred because less than 4mA can indicate a fault or open circuit, also there is at least 4mA available to power equipment
7 segment	type of display configuration - where 7 segments can be used to form the numbers 0 through 9 and most letters
A/D	analog to digital - a device or circuit that converts an analog voltage to a digital number
absorption	retention by penetration into bulk of material
adsorption	retention as a surface layer on a material
accuracy	quantification of the magnitude of error of a measurement, or degree of conformity with a standard.
Al ₂ O ₃	aluminum oxide
ATEX	(ATmospheres EXplosibles) directive defines the requirements upon equipment to be installed in Hazardous Locations. Only products with the ATEX certification and with ATEX labeling are approved for placing into service in Hazardous Locations in the EU (European Union) and EFTA (European Free Trade Association) countries.
attenuation.	the decrease in intensity of a signal, as a result of absorption of energy, measured in decibels (dB).
AWG	American Wire Gauge (size of the wire, cross section area of the wire)
baud.	Bits per second of data transfer (over the serial interface)
bit(s)	Binary digit(s) - ones and zeros
BNC	a connector type, used with coaxial cables
bypass mounting	sensor mounting in a slip stream of sample, which feeds back into the process stream
CE	Conformité Européenne; symbol affixed to a product indicating its conformance with directives issued by the European Community (EC)
CENELEC	Comité Européen de Normalisation Electrotechnique (European Committee for Electrotechnical Standardization).
check sum	an arithmetic total on a set of data: e.g. the data in the instrument's memory is summed, and compared to a previously stored sum to check for corrupted data
coalescing	formation of liquids in gas samples, or separation and collection for disposal of liquids from gas samples
control drawing.	schematics and system drawing of hazardous area approved apparatus with control number issued by approval agency
CSA.	Canadian Standards Association

CTS	Clear To Send - a label for a RS232 interface control line
cUL	indicates UL evaluation of a product to Canadian safety requirements
current loop	a circuit where the variation in the current flow is used to indicate the value of a measurement from the instrument, only 2 wires are used for the circuit (see 4/20)
dB	see - decibel
DB25	a style and size of connector - in this case with 25 pins
DB9	a style and size of connector - in this case with 9 pins
decibel	a dimensionless unit representing the logarithm of the ratio of two values
DEMKO	independent test laboratory and the European National Certification Body for Denmark for the safety testing of electrical products
desiccant	drying agent, usually made from molecular sieve, silica gel or activated alumina
desorption	release of a previously absorbed or adsorbed substance
dewpoint	saturation temperature of a gas in regards to another gas
dewpoint demand mode	... scheme to control the switching between the desiccant towers of a dryer based on the actual dewpoint
dielectric constant	... measure of the ability of a material to hold an electric charge when placed between two metal plates, most commonly measured relative to that of free space
Div 2	... see Division 2 Hazardous Areas
Division 2	
Hazardous Areas	... areas classified as hazardous under abnormal conditions (0.1-10 hrs/year)
DSR	Data Set Ready - a label for a RS232 interface control line
DTR	Data Terminal Ready - a label for a RS232 control line
EEPROM	Electrically Erasable Programmable Read Only Memory - a device that can remember information, even when it has no power applied to it
electromagnetic	
compatibility	... compatibility with directives issued under CE or with FCC standards, concerning electromagnetic interference
EMI	Electro-Magnetic Interference - external electrical or magnetic signals from natural or man-made sources that can interfere with a device
G/M ³	... see - grams per cubic meter
grams per cubic meter	... the mass of water vapor present in unit volume of moist air at standard temperature and pressure.
HTF™	Hyper-Thin-Film aluminum oxide sensor technology developed by Xentaur Corp
hygrometer	... device measuring the amount of water present in a sample
hygroscopic	... property of attracting water or water vapor
hysteresis	... lagging in effect behind it's cause depending upon whether the condition is approached from above or below the value of interest; pur-

	posefully programmed into control systems with relays to avoid chatter
IGT Research Bulletin 8	Institute of Gas Technology, has developed Charts of the Equilibrium Moisture Content of Natural Gases in the Range of -40°F to 250°F and 14.7 to 5000 psi
impedance	the ratio of voltage to current at a specified frequency measured in Ohms, a resistor of the same value would act the same as the measured circuit
in-hand micro-climate.	the warm and moist “climate” created when cupping the sensor in ones hand.
in-situ	measurement with sensor located in the process stream
intrinsically safe	incapable of releasing enough electrical or thermal energy to cause the ignition of flammable substances listed for a hazardous area classification
LBS H ₂ O/mmscf.	see - pounds of water per million standard cubic feet
LCD	Liquid Crystal Display - a display that uses a special material (that is sensitive to electrical voltages) to affect the transmission or reflection of light
monograph	a systematic learned exposition of a subject, e.g. a chart representing dewpoint conversions for differing pressures.
National Electrical Code	a set of US standards related to accepted practices for electrical wiring
NFPA.	National Fire Protection Agency (issuer of the National Electrical Code (NEC))
NIST	National Institute of Standards and Technology
NPT	National (American Standard) Pipe Taper; an ASTM (American Society for Testing and Materials) standard of tube fittings with tapered threads
parity	a way of incorporating error checking into a RS232 data transmission (on a character by character basis) to check if the data has been received correctly
pounds of water per million standard cubic feet .	(LBS H ₂ O/mmscf) the mass of water vapor present in unit volume of moist air at standard temperature and pressure. a measurement unit for moisture, typically used in the natural gas industry
ppm	parts per million - usually based on volume measure, but must be stated whether it is by volume or by mass (weight)
ppmV	parts per million based on volume measure, volume of water vapor per total volume of gas for an ideal gas.
pressure correction	computation of dewpoint at a pressure different from the pressure at the sensor
PROM.	Programmable Read Only Memory - a device that can be programmed so that data is permanently stored in it (typically used for computer programs)
RAM	Random Access Memory - a device that holds data as long as it has

- power applied to it (the data can be changed with out limit)
- regenerative dryer purge small flow of dry air from drying column passing through regener-
ating column and desorbing water from desiccant at low pressure
- response time time it takes for a sensor to react to change in its environment
- RG58. a type of coaxial cable - the letters/numbers refer to the electrical
characteristic of the cable (resistance/capacitance per foot of
length)
- RG6. A type of coaxial cable - the letters/numbers refer to the electrical
characteristic of the cable (resistance/capacitance per foot of
length)
- RS-232C a specification for electrical signaling (also referred to as RS232)
that describes the voltages, rate of change of the voltages, and the
signal names and uses for the signals
- RTS Request To Send - a label for a RS232 interface control line
- sample system. equipment used to bring conditioned sample to the sensing element;
it may include regulators, filters, heaters/coolers, flow meters,
valves and other accessories.
- saturate reaching maximum holding capacity
- sintered produced by a process of compacting and heating metal powder,
resulting in the formation of a solid, permeable object.
- slip stream. partial stream extracted from a process stream, of which it is repre-
sentative
- SpanCheck™ method to check the response of an HTF™ sensor at the upper end
of its measurement range
- stability a measurement's degree of insensitivity to disturbances.
- UL. Underwriters Laboratories Inc., an organization which evaluates,
tests and certifies products for specific safety situations.
- uncertainty quantification of the error that can be expected from a measure-
ment, characterizing the range in which the true value can be
expected to be in.

Appendix A: Flow Diagram of Operating State User Interface

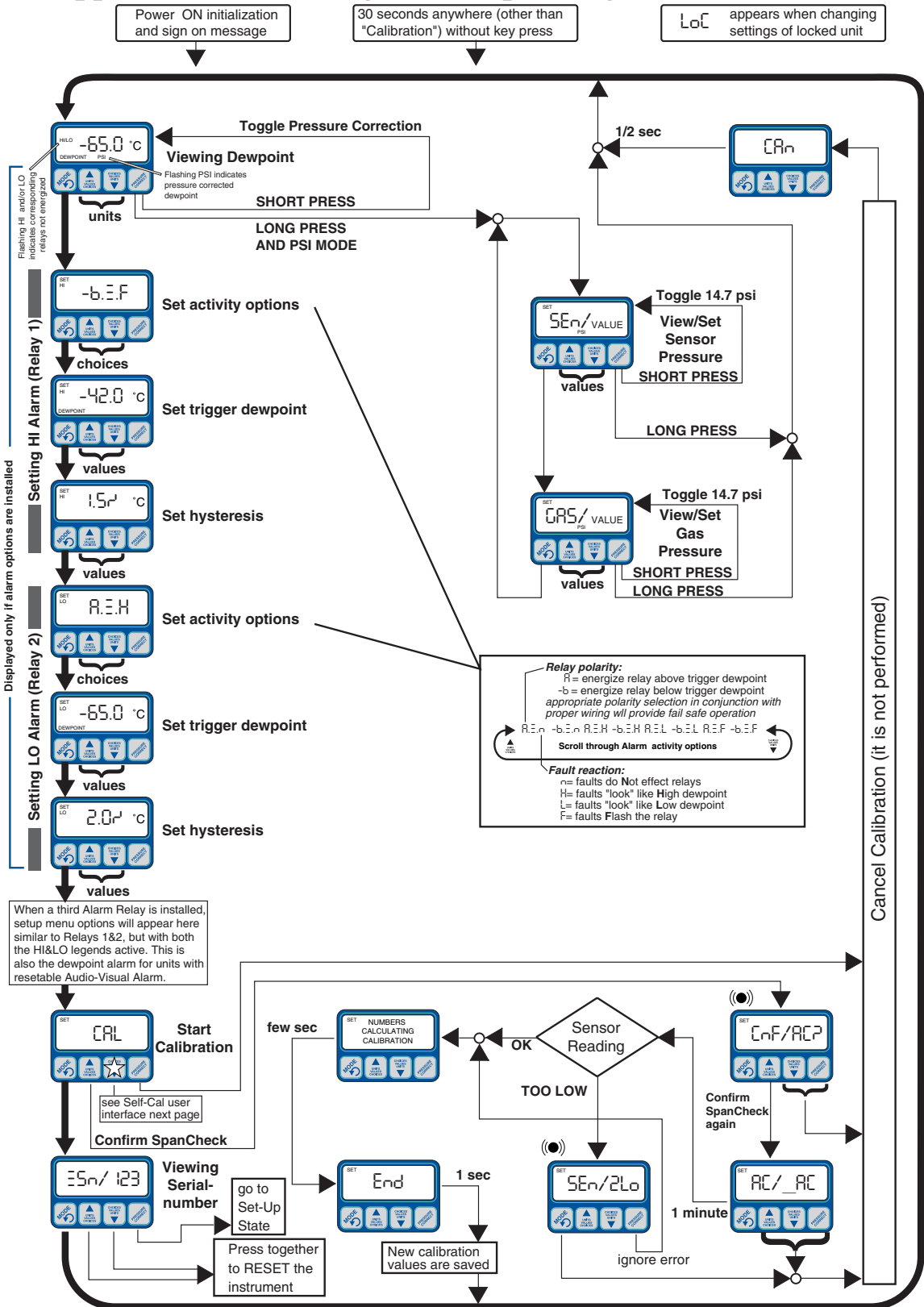

Flow Diagram Operating State User Interface (continued) Manual & Scheduled Self Calibration

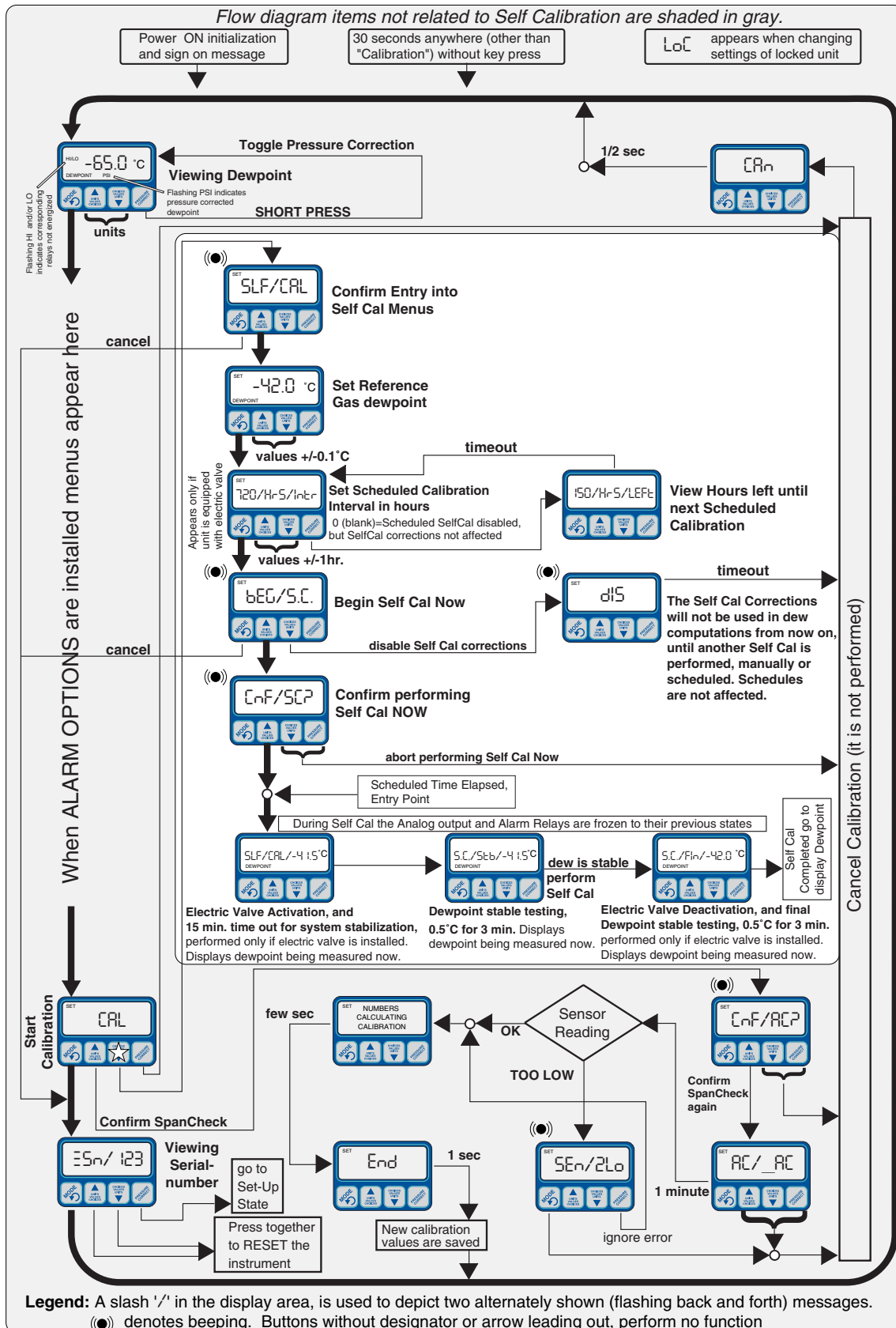

Appendix B: Flow Diagram of Set-Up State User Interface

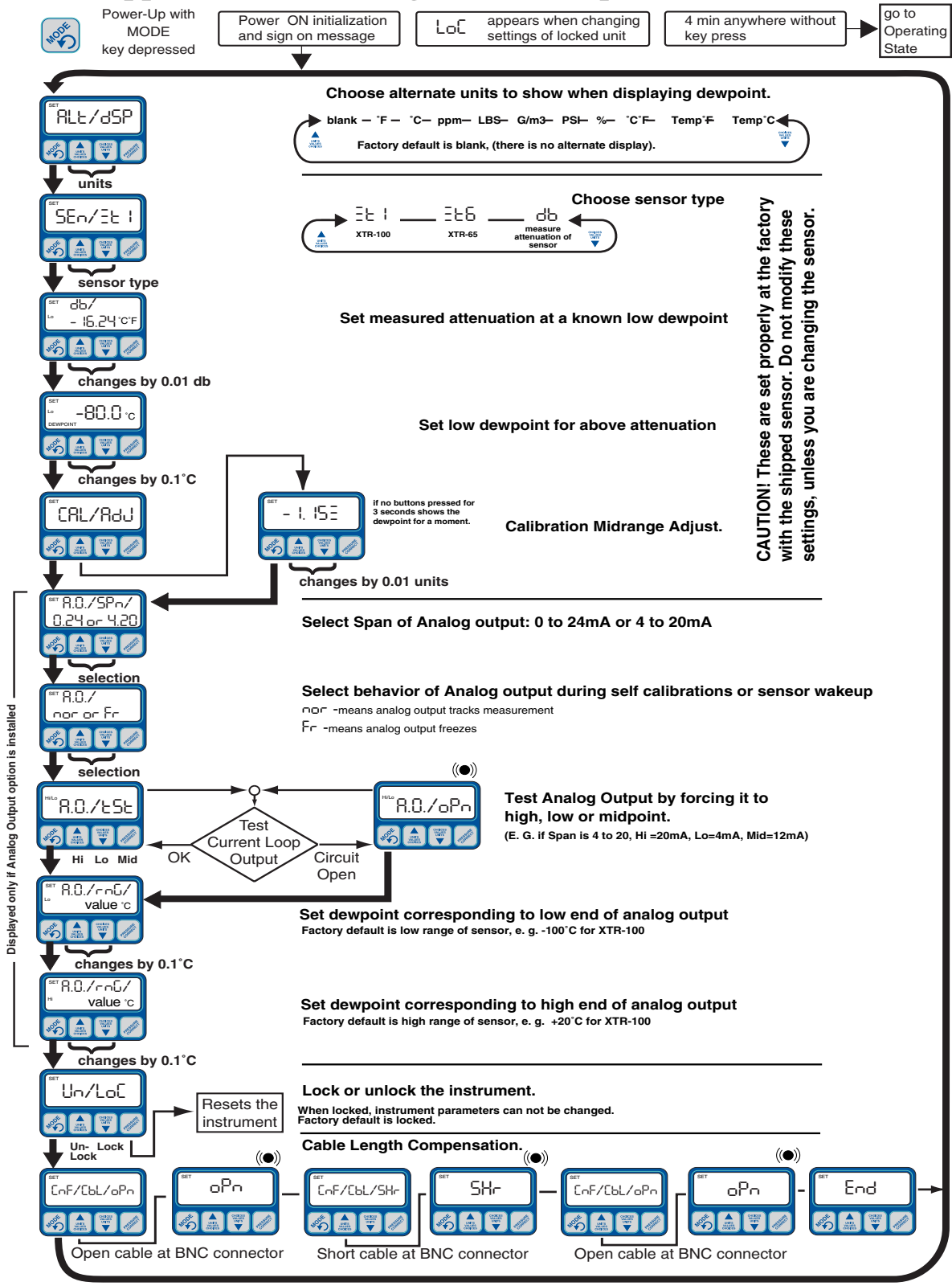

Legend: A slash '/' in the display area, is used to depict two alternately shown (flashing back and forth) messages. (●) denotes beeping. Buttons without designator or arrow leading out, perform no function

Appendix C: Sensor Mechanical

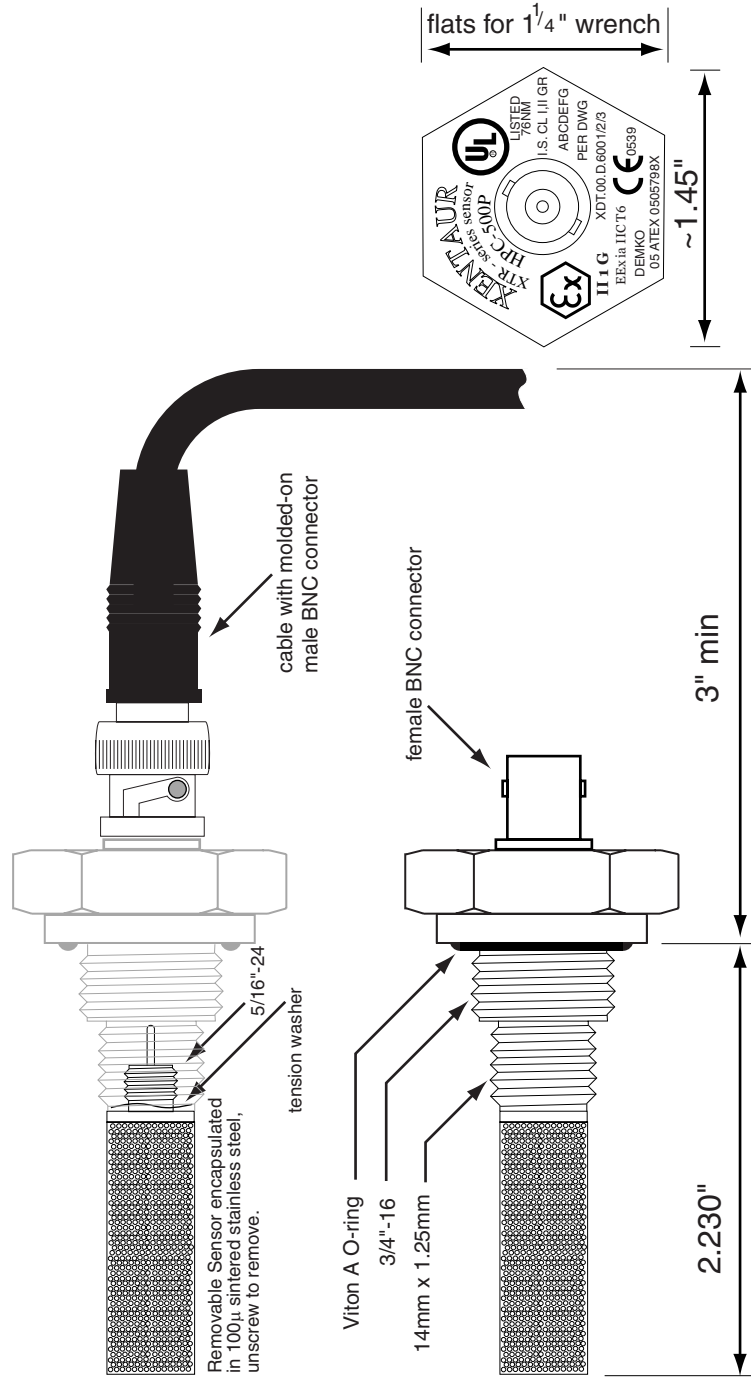

Appendix D: Optional Sensor Fittings

5/8-18 thread fitting
SEO.52.C.1500

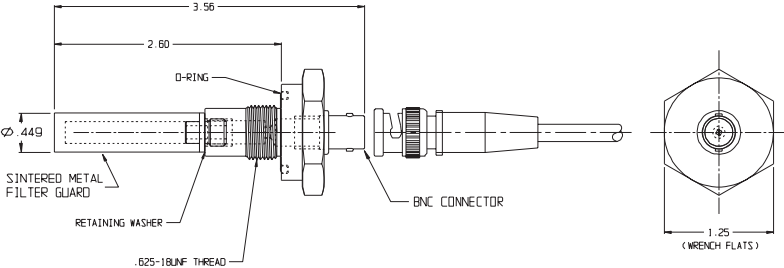

G 1/2 thread fitting
SEO.50.M.1600

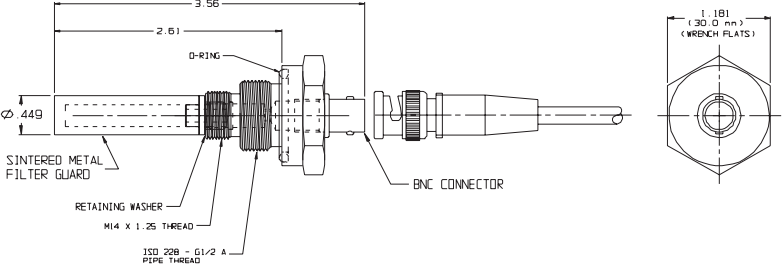

14mm thread only fitting
for special SHAW replacement
SEO.50.C.4000

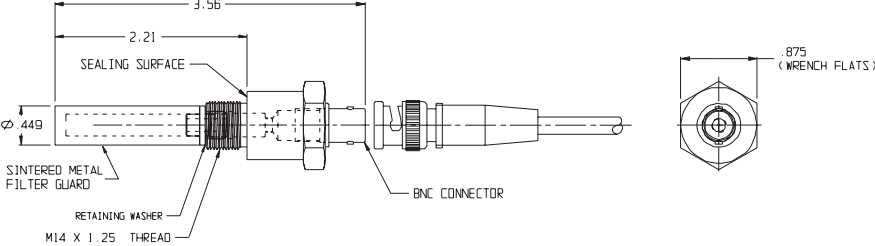

1/2"NPT fitting
SEO.50.C.1016

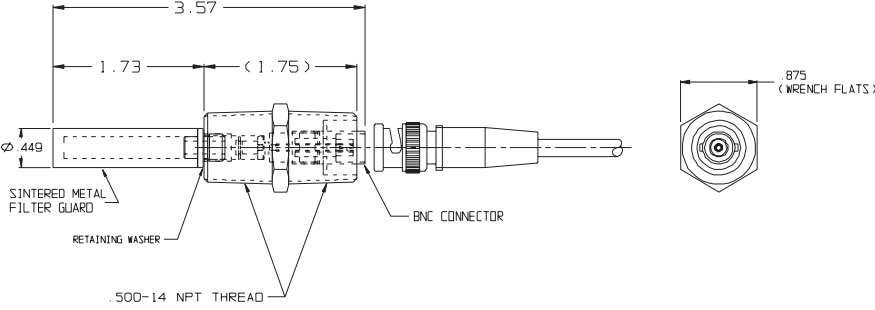

Standard fitting with NPT connector shell
to allow weatherproofing
SEO.51.M.1710

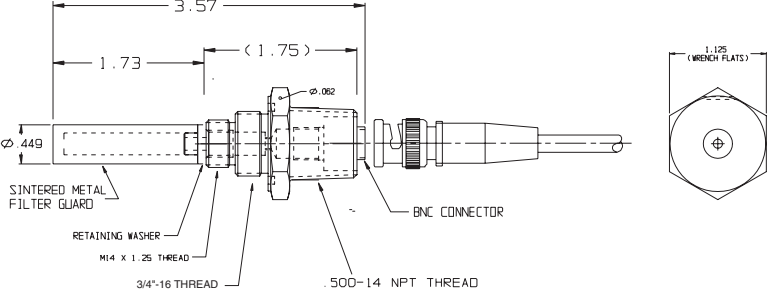

can be used with
Connector weatherproofing kit SEO.S1.M.5060
to protect the BNC connector

Part numbers are for fittings only, for reference shown with BNC cable & installed sensors.

Appendix E: XDT Circuit Board Dimensions

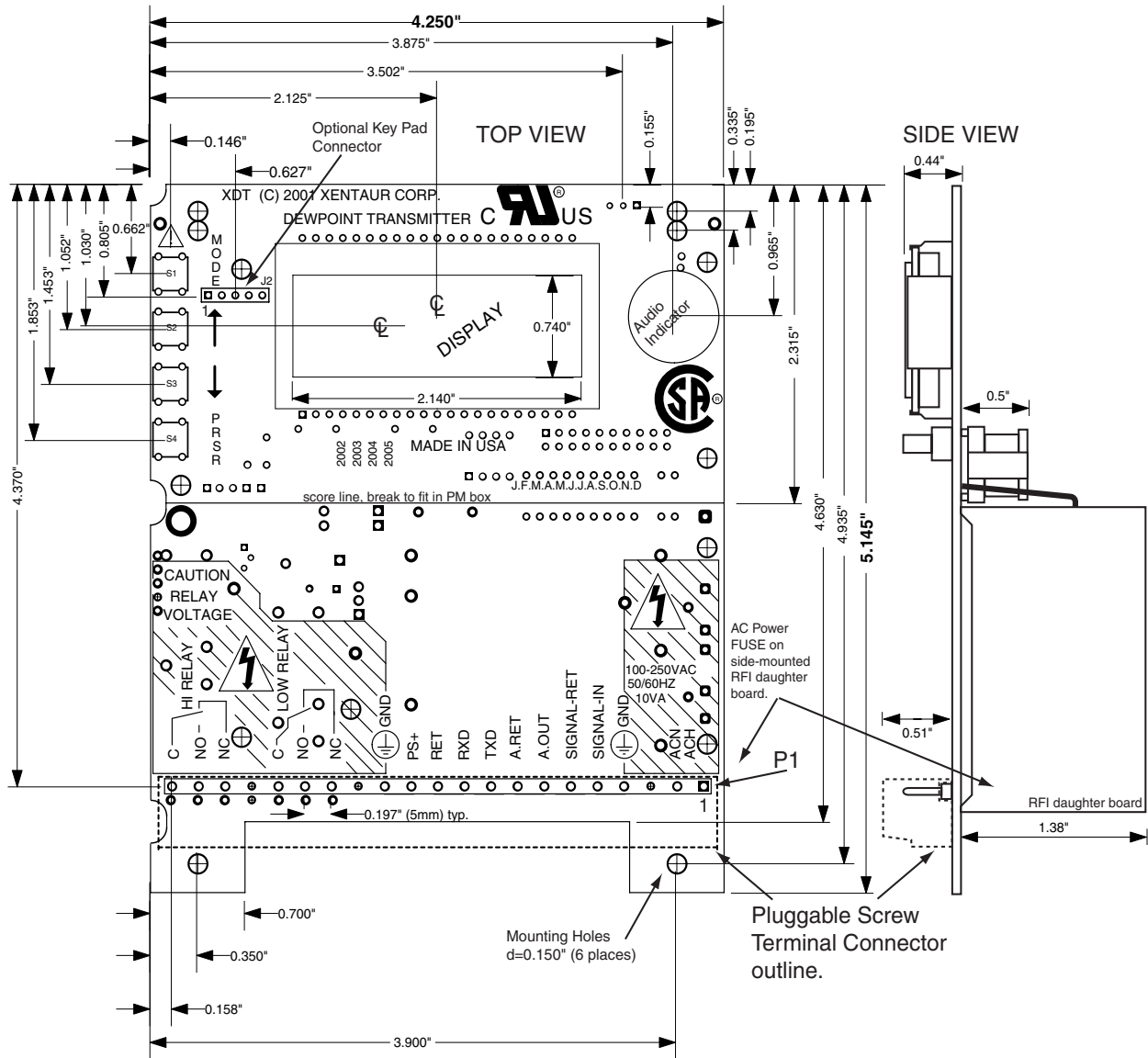

Appendix E (continued): XDT-PM Enclosure Mounting Dimensions

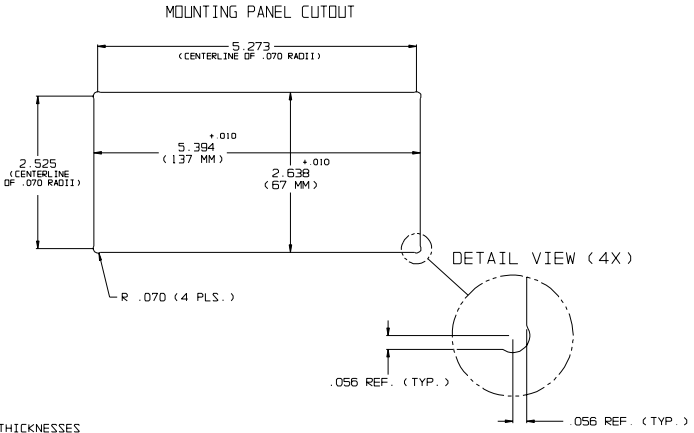
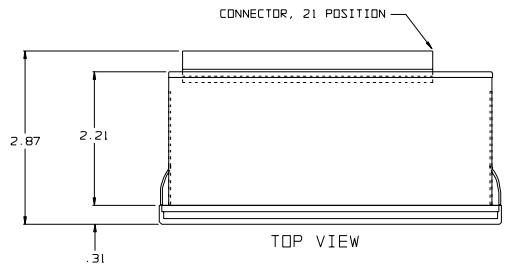
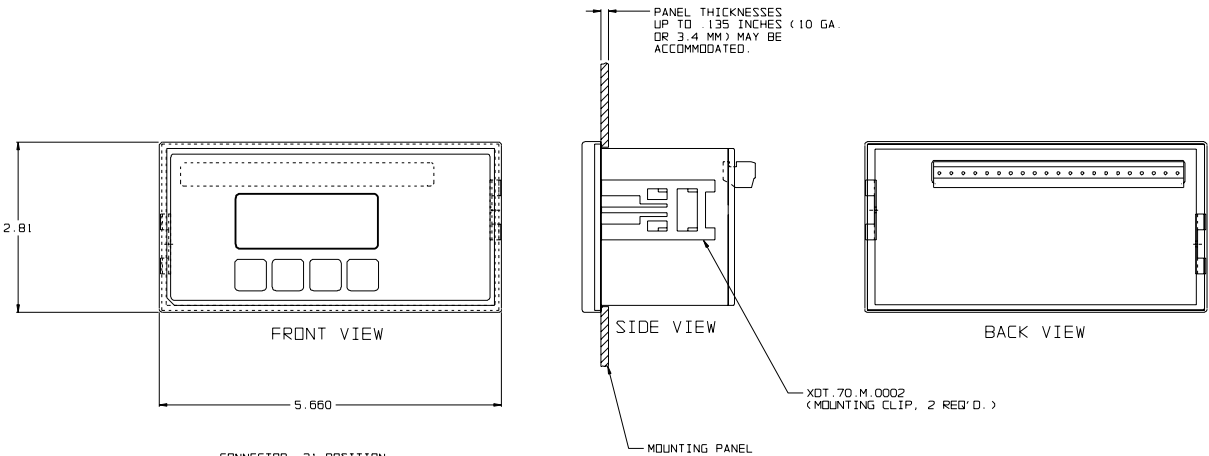

Standard mounting
(with clip-on compression brackets)
Environmentally sealed mounting
(with gasket and clip-on screw clamp mounting brackets)

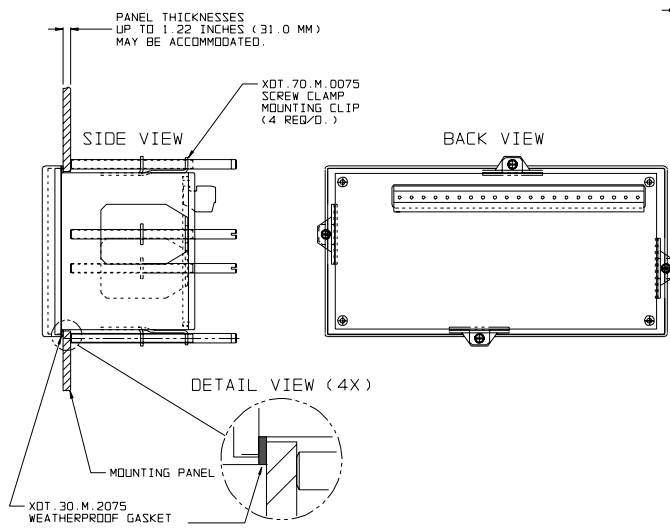
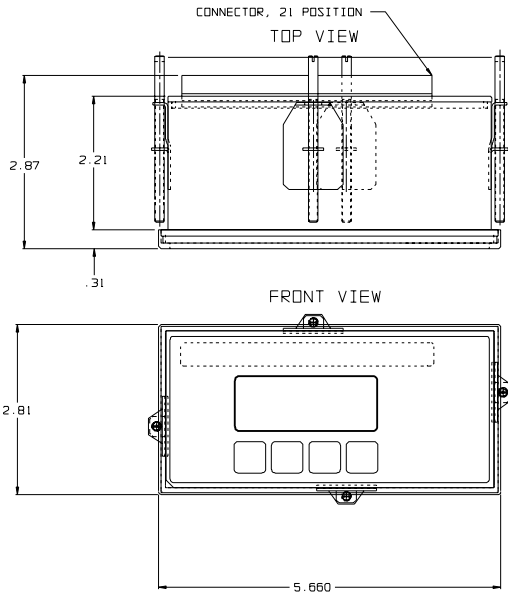

Appendix E (continued): XDT-NEMA Enclosure Mounting Dimensions

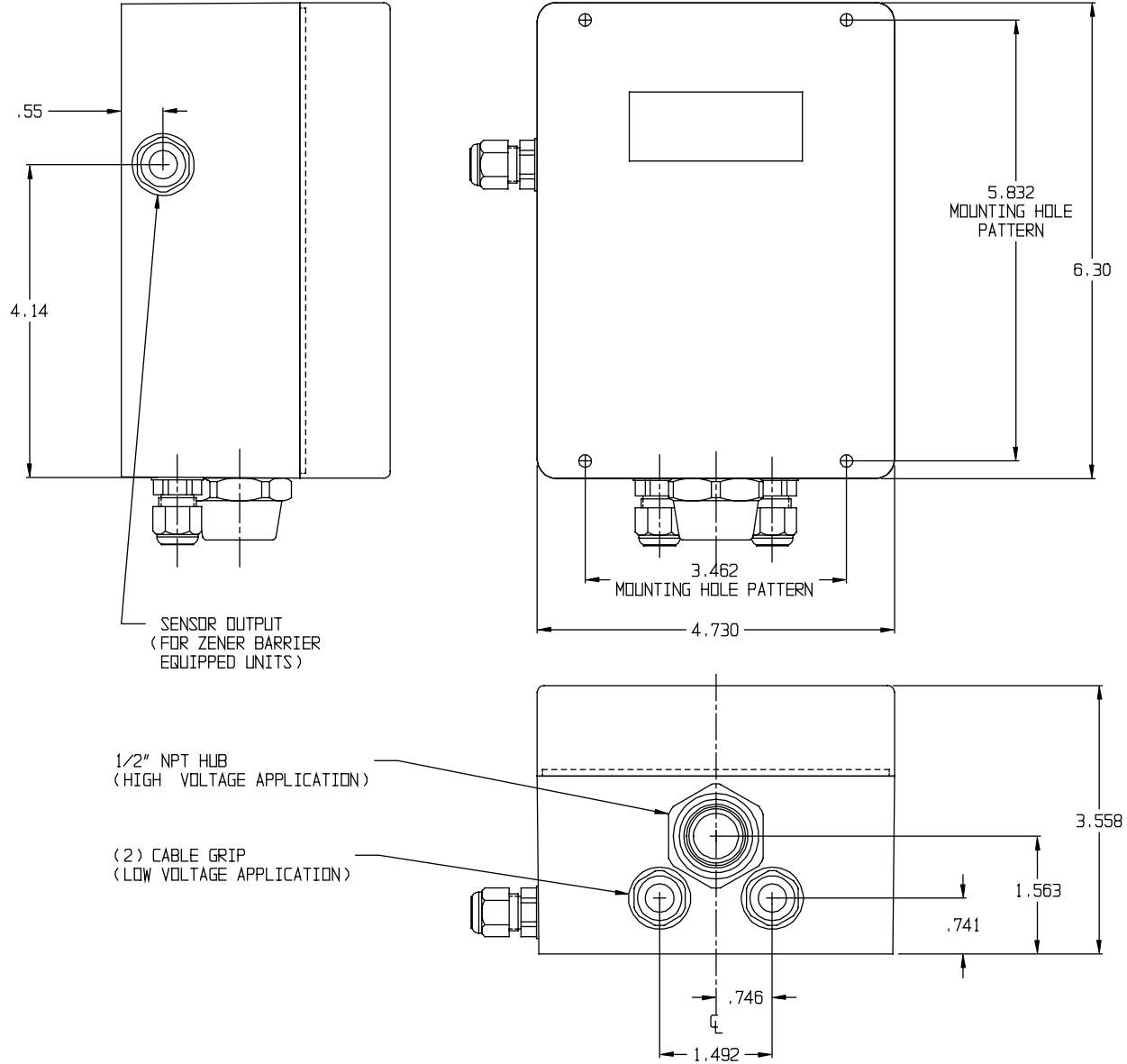

Appendix F: Sensor/SpanCheck™ Theory of Operation

The Sensor is constructed as a capacitor whose dielectric consists of porous Aluminum Oxide as well as the gas that has entered in the pores of the Aluminum Oxide. The plates (electrodes) of this capacitor are an aluminum substrate and a porous gold layer deposited on top of the Aluminum Oxide, the porous gold electrode allows transfer of gases into or out of the Aluminum Oxide pores.

The capacitance due to the Aluminum Oxide is always constant, while the capacitance due to the gas varies according to the gas content and pressure. Since the dielectric constant of water is orders of magnitude larger than that of any gases being measured, the quantity of water vapor present in the pores changes the capacitance of the sensor to a much greater extent than any other system variable. For the same reason (the extremely large dielectric constant of the water molecule), any capacitance variations arising from the Aluminum Oxide, such as changes due to temperature, are insignificant in relation to the capacitance due to the water content. Thus the sensor capacitance varies greatly in proportion to the water content in the surrounding gas. The sensor is designed such that the relationship of the quantity of water and the resultant capacitance has an "S" shaped curve. At the extremely dry end the curve is asymptotic to the capacitance due to the Aluminum Oxide and the gas, while at the very wet end the curve is asymptotic to the capacitance due to water molecules packed extremely tightly (saturated) in the pores of the Aluminum Oxide. This upper end is an excellent indication of the total pore volume; while the lower end of the curve is an indication of the distance between, & area of the capacitor plates (electrodes), this is the intrinsic capacitance of the sensor. Therefore knowing these two points, a sensor can be calibrated with compensation for small manufacturing deviations.

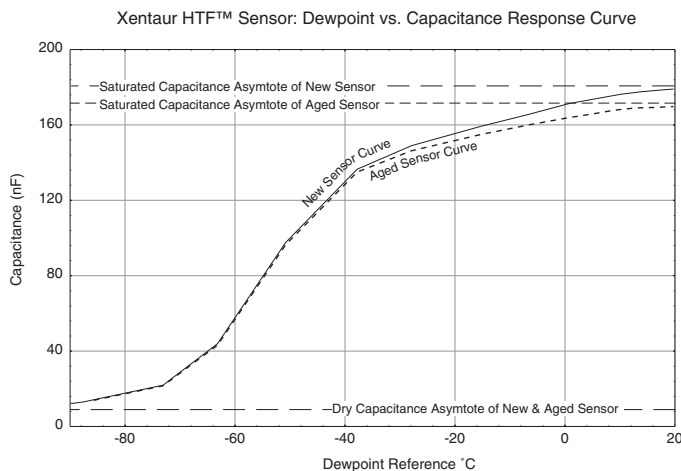

As the sensor is used in real world applications, it is exposed to various elements and stress; like any other sensor it may over time drift from calibration. However one must note that the intrinsic capacitance will not change with use because it is based simply on the dielectric constant of Al₂O₃ and the distance between, & area of the plates (electrodes), thus the original factory measured values will always be valid. What may change is the pore volume, due to clogging with contaminants, residual oxidation, metal migration, etc.

Thus to re-calibrate the sensor the instrument needs only to “know” the capacitance at the wet end of the curve. As discussed previously the capacitance at the wet end approaches asymptotically a saturated pore capacitance, therefore if the sensor is saturated (the exact water content will not be important since the curve is asymptotic), then the instrument can measure the capacitance and re-calibrate the sensor. This is referred to as SpanCheck™. The advantages of this unique capability of Xentaur HTF™ sensors and instruments are obvious in time and cost savings for re-calibration, as well as ease of sensor replacement.

Appendix G: Dewpoint Response time Analysis

Manufacturers of dewpoint sensors will make unbelievable claims of speed. But without supporting data revealing the conditions under which the measurements were made, such as flow rate, temperature, the dewpoint at which the test was performed, and most importantly the units of measure. This last aspect can be extremely deceiving, consider the following example.

At Xentaur we have performed a variety of tests to determine the response time of ours as well as the competitor's sensors. For this discussion let's consider a step change of -40°C to -60°C dewpoint, in other words a challenging but typical dry-down. An XTR-100 sensor w/SS sintered filter was placed in an electro-polished stainless steel manifold, the temperature was 23°C and the sample flow rate was 3 LPM. The dewpoint was generated with a computer controlled mass flow valve gas dilution dewpoint generator, and was verified with a NIST and NPL calibrated MBW chilled mirror. The system was allowed to achieve equilibrium at -40°C dp overnight, then the dewpoint was abruptly changed to -60°C , the change is depicted below as time 0.

The graph below shows the percent change of recorded dewpoint ($^{\circ}\text{C}$), the same data is also shown in percent change of the recorded dewpoint converted to ppmV. It is immediately obvious how a sensor that has response times exceeding ten minutes can be claimed to have response time of 3 minutes, simply by manipulating the units of measure. The logarithmic relationship between dewpoint and ppmV makes the ppmV reading appear faster. Since the response time is stated in percent change, the units of measure are automatically hidden from the audience.

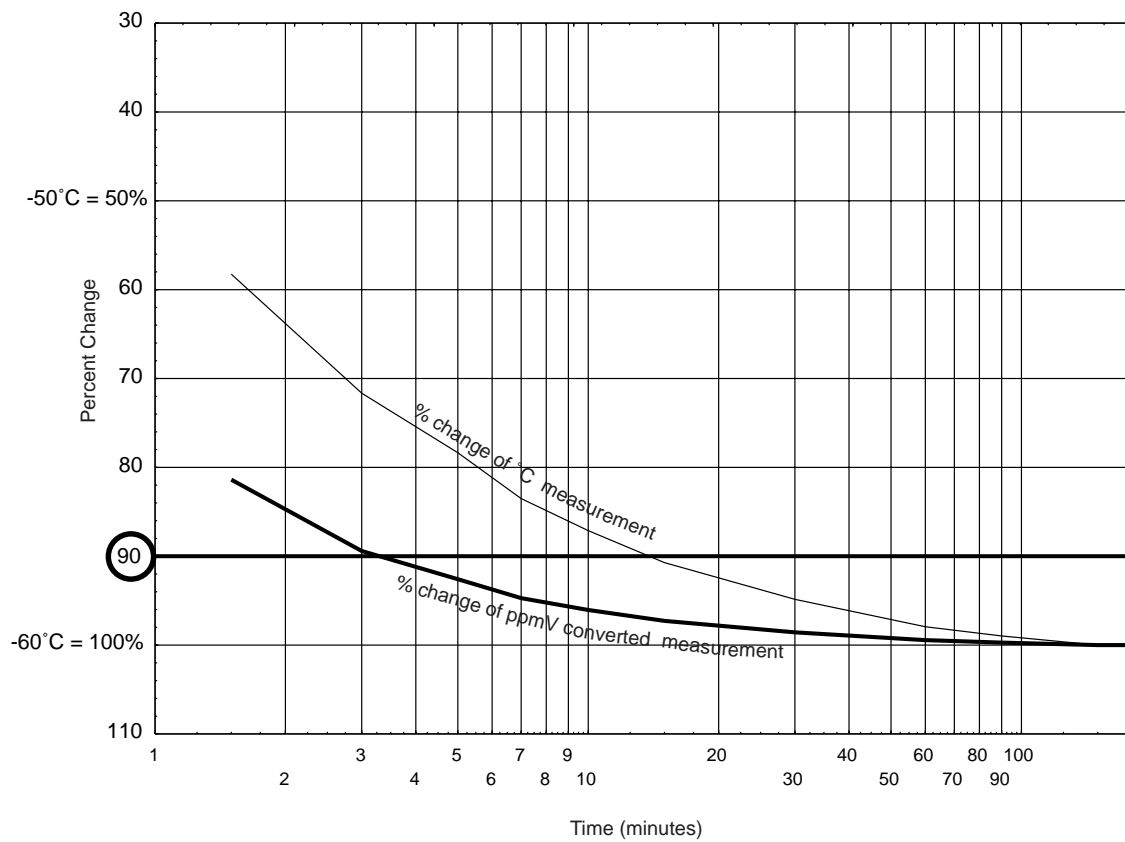

Of course analyzing on a wet-up step will produce much faster results, because all sensors are fast on wet up, since Al_2O_3 (like most materials) adsorbs faster than it desorbs. Testing with a small step e.g. in the -10°C to 0°C dewpoint range will produce even faster results, and allow manufacturers to make far-fetched claims of response time of 5seconds for a 90% of step change. The customer has to be aware of these manipulations of data and be able to ascertain the real-world response time they can expect out of a sensor.

As can be seen from the graph the Xentaur sensor is appreciably faster than any competitors'. This is due to the Hyper Thin Film (HTF) technology, an explanation of the workings of the sensor is provided in the Xentaur Hyper-Thin-Film (HTF) Aluminum Oxide Technology notes. We can comfortably make the claim that the Xentaur XTR-100 sensor is faster than any on the market today.

To compensate for their sensors' slow response some manufacturers resort to software acceleration of response time, even though this scheme provides a seemingly faster response to a single step change, it creates great errors in real systems where multiple changes occur consecutively in differing directions. The sensors' real response lag to consecutive step changes in differing directions is erroneously interpreted as belonging to a single step change, and thus large errors of measurement are introduced for long periods of time. An analogy of this situation can be imagined with a defender in a football (soccer) game. A slow player cannot defend by just anticipating the next move of the forward wing; he will simply be faked out by a series of back and forth maneuvers (consecutive step changes in differing directions). While a fast defender cannot be faked out, he simply follows the forward wing as fast as he moves (Hyper Thin Film).

Appendix H: Sample Gas Filter Considerations

Sample treatment with pre-filtering may be a necessity in many instances. However the filter housing and element may affect the dewpoint reading and/or the response time of the system. Below is a graph comparing measurements from the same calibrated sensor with and without a filter utilizing a polycarbonate bowl. All other parameters, which may affect the measurement, were kept constant. Outside of the sample system, a rather hot and humid environment was created, to illustrate a worse case condition. As can be seen the filter does not cause problems for dewpoints greater than -50°C . However the systems' ability to make precise measurements quickly deteriorates for dewpoints below -55°C .

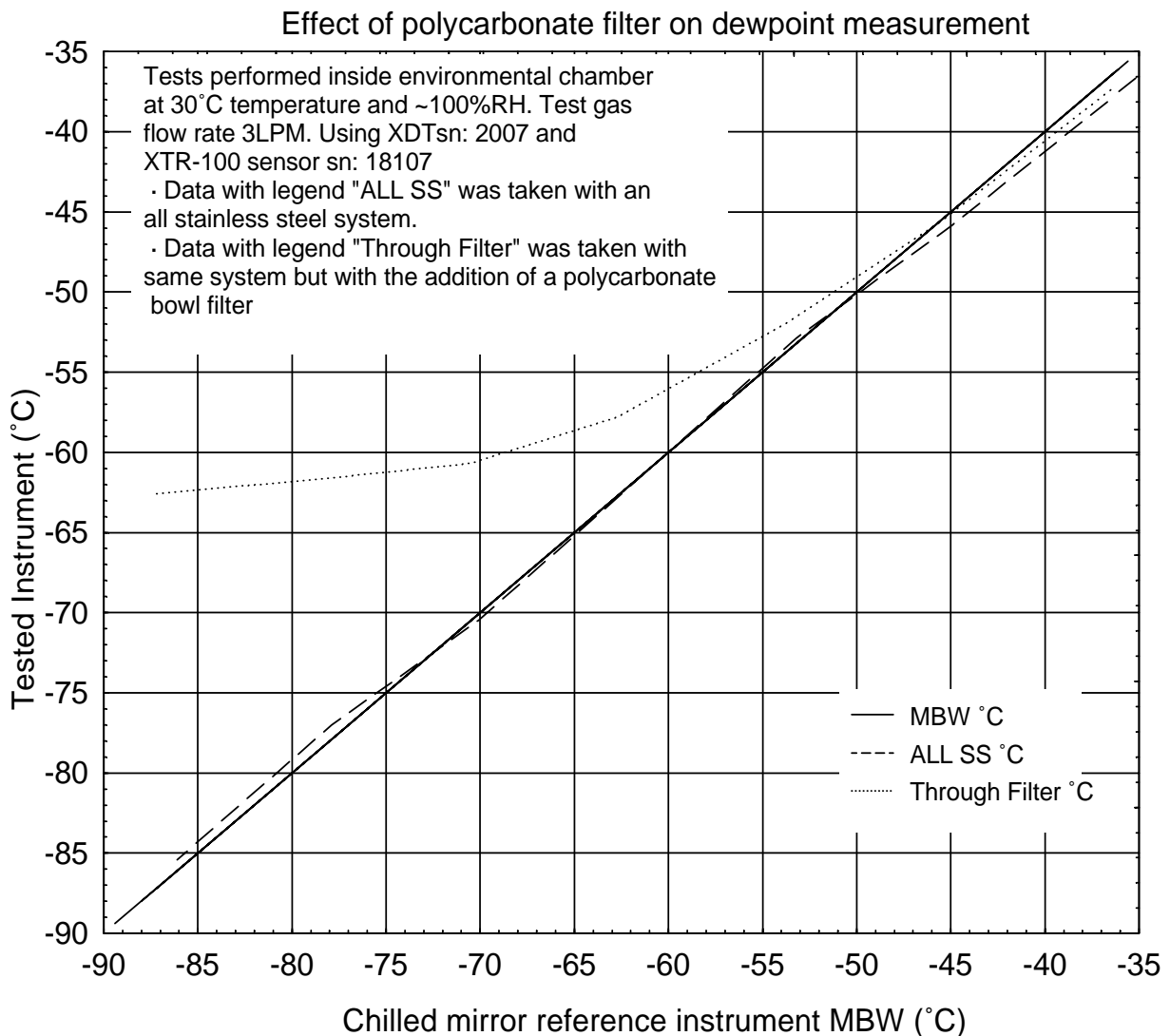

With this in mind the user should select the appropriate filter construction materials. It is important to note that a stainless steel housing filter will not cause measurement errors, however if the filter element inside the housing is made of hygroscopic fibers, then there will be a delay introduced in the measurement.

Appendix I: XDT Grounding Considerations

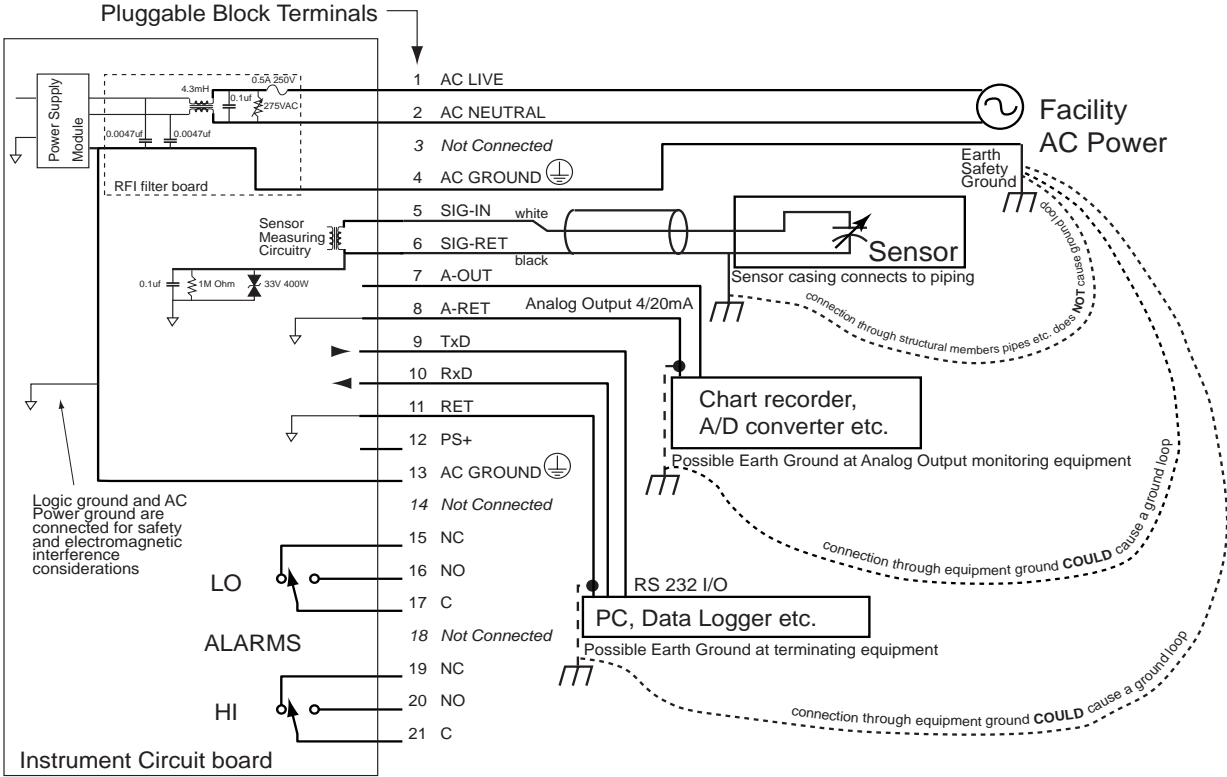

1. The sensor ground is isolated from the signal and frame grounds, however it is shunted to frame ground with a 33V Transient Voltage Suppressor, 1M Ohm resistor and 0.1uF capacitor to prevent electrostatic buildup and noise pickup. When the sensor is connected to equipment which is grounded to earth ground (because of pipes etc.), there is no ground loop because the sensor is not connected to the earth ground on the circuit board.
2. The optional Analog Output and RS-232 Output are both referenced to the circuit board logic ground, which is jumpered at a single point to the AC power ground. Therefore if these outputs are connected to equipment which connects the signal grounds to earth ground (this is a common occurrence in PC's), then a ground loop may be formed. This can be best avoided by removing the signal to earth ground connection at the termination equipment; if that is not possible then the AC power ground connection to XDT logic ground may be removed but this may cause a EMI problem. Please consult with your representative for information on optional isolated analog and RS-232 outputs. Keep in mind that in general, a ground loop on a digital line such as RS-232 will not cause problems.
3. The Earth Safety Ground (AC GROUND) at pin 4, should not be omitted since the RFI filter capacitors will cause half the line voltage to develop at the instrument's ground. This may have safety and EMI implications.
4. When installing DC powered instruments (15 to 30VDC at pins #12 and #11), similar conditions may exist, if the DC power source is earth grounded.

Appendix J: Analog Output vs. Dewpoint

The current output of the XDT, varies with the measured dewpoint. To use the current to calculate the value of the dewpoint measurement, one must know the settings of the low and high ends of the analog output range, then:

$$D = \frac{(I - Z) \times (H - L)}{S} + L$$

where: I = current supplied by XDT analog output in mA.
 Z = value of zero output of current loop in mA: for 4/20 = 4, for 0/24 = 0.
 H = value of High end of Analog Output range, converted to selected engineering units
 L = value of Low end of Analog Output range, converted to selected engineering units
 D = dewpoint measured by instrument in selected engineering units.
 S = span in mA of current loop output: for 4/20 = 16, for 0/24 = 24.

Consult section 3.4.5.7&8 and/or appendix B, to check and set the Analog Output low and high ranges; the factory default settings are -100°C and +20°C respectively.

For example a unit with factory default settings, supplying 12mA is computed to be measuring a dewpoint of -40°C:

$$\frac{(12 - 4) \times (20 - (-100))}{16} + (-100) = -40$$

Note that the computation is such that the current is linear to the selected engineering units. Hence, selecting ppmV or LBS or G/M3 units, will cause the analog output to be linearly proportional to those units (approximately logarithmically proportional to dewpoint), refer to the graph that follows. Naturally selecting °C or °F will cause the analog output to be linearly proportional to dewpoint.

When monitoring in ppmV or LBS or G/M3, the analog output low & high ranges may have to be adjusted to provide a useful output. Consider an example where the area of interest to be monitored is 10 to 100 ppmV, and the analog output is set up with the factory defaults of -100°C to +20°C (which is 0.014 to 23612 ppmV); then the current loop output will vary only from ~4.1 to ~4.2 mA in the area of interest (consult with the graph on the following page). In most instances this would be an unacceptable output for proper monitoring of the measurement. In this example the user should adjust the analog output low & high ranges such that the output range is better suited to the measurement of 10 to 100 ppmV. It may be useful to select the low and high ranges to be 5 and 150 ppmV respectively, thus out of range conditions will be detected properly. Then the low range will be set to 5ppmV which is -65.5°C dewpoint, and the high range will be set to 150ppmV which is -38.5°C dewpoint. Now the current loop output will be 4.55 to 14.48 mA in the range of 10 to 100 ppmV, the ~10mA variation is more than sufficient for a good measurement by the user's equipment. One may carry out similar calculations for LBS or G/M3 and choose the appropriate settings. While making these computations it may be useful to obtain a copy of Xentaur's dewpoint calculator, this is a Microsoft Windows™ program which simplifies the process of converting dewpoint measurement units. It is available at www.xentaur.com. If you are not certain how to carry out such calculations, send by e-mail to xentaur@xentaur.com or by fax to (631) 345-5349, your system specifics, and some one will get back to you with appropriate analog output settings.

In general, if the dewpoint is monitored in °C or °F, there is no need to change the factory default

-100°C to +20°C settings, because the 4-20mA provides sufficient resolution to measure the output better than the specified accuracy of the sensor.

Relationship of 4-20mA output and instrument reading in ppmV or LBS

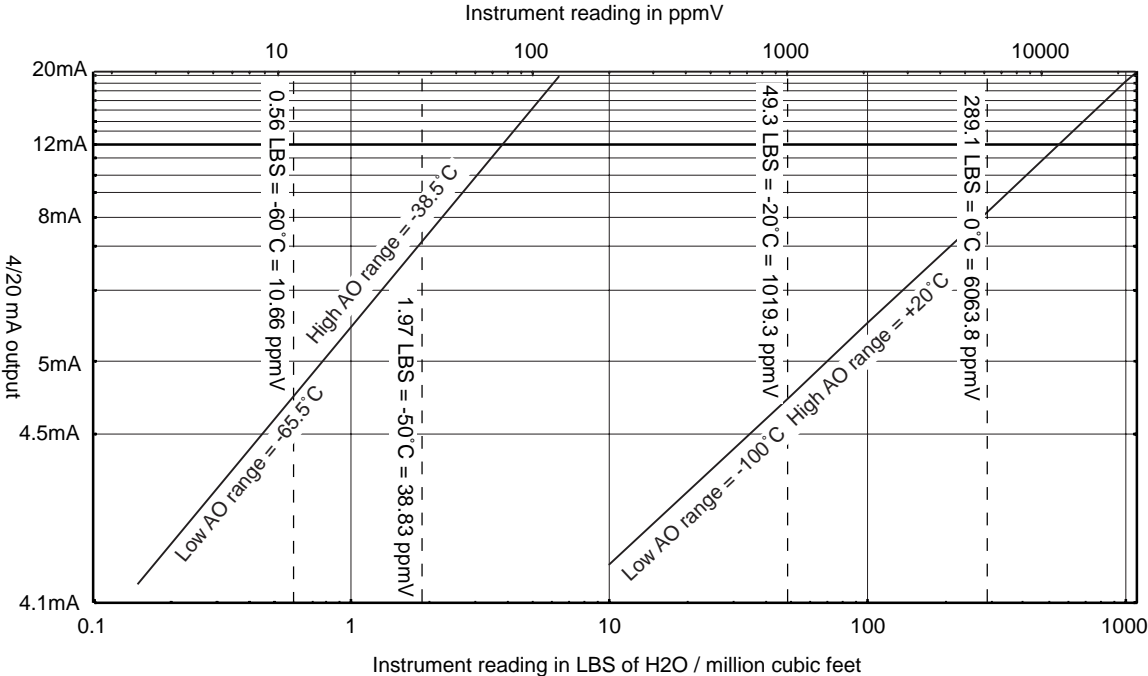

Appendix K: RS-232C Interface Protocol

The instrument uses a simple protocol to communicate to a host computer through its RS-232C interface, see section 3.3.2.5 for electrical connections. The interface is configured as 9600 baud, Even Parity, 8 Bits, 1 Stop; and it echoes all received characters.

To illustrate the protocol, the following notation conventions are used in this section:

The characters sent or received are depicted in bold. Send refers to sending from the host computer to the XDT. Receive refers to receiving from the XDT into the host computer. The commands and arguments are shown in capital letters while place holders for choices are labeled with lowercase italic letters, with the allowed characters shown below, "nn" denotes a numeric value. Bytes which are not characters are shown with diagonally placed mnemonics, for example Escape is depicted as $^E S_C$, this signifies a single byte (hex 1B). Optional characters or command arguments are encompassed with brackets [].

The commands may be sent in either upper or lower case. Arguments may be delimited with space or comma.

HELP command

Lists all of the available commands.

send: **H[ELP]^C_R**

receive: **Help** ? **Data** **SN^C_R ^L_F**
 Who **Reset** **Login^C_R ^L_F**

DATA command

Selects the reporting format of the current measurement.

This formatting will be retained until the next DATA command even if the power is turned off.

send: **DA[TA] *units* [*interval* [*mode*]]^C_R**

C	nn	N
F		G
P		
L		
G		
D		
U		

The *units* argument selects the units in which the measurement will be reported.

C,F,P,L & G select the dewpoint in °C,°F,ppm,Lbs H₂O/mmscf and gm/m³ respectively.

D selects decibels which is the measured sensor attenuation.

U selects using whatever units are selected by the user on the display.

The *interval* argument is optional, if it is not entered then the measurement will be reported only on a query with the "?" command. However if it is desired for the unit to report the measurement on a regular interval without a query then an interval in seconds may be specified in the range 1 to 255 seconds. This feature allows the user to log the measurement on a dumb terminal or a printer.

The *mode* argument is optional and may be specified only if an interval was specified. It may be “N” for numeric reporting or “G” for graphic reporting of the measurement. The mode argument defaults to numeric mode. The graphic mode may be chosen only for °C or °F, it will plot a graph of the measurement on printers which can respond to the Epson Graphic Commands, and have at least 80 character columns.

In the NUMERIC mode the instrument will report the measurement in the following format

B_LMeasurement Units^{S_P}Elapsed Time^{S_P}Alarm Status^{C_R}L_F

The bell character is used to denote the beginning of each line. The measurement is a floating point decimal number. The units are the appropriate character string: “degF”, “degC”, “ppmV”, “LbsH2O/mmscf” or “g/m3”. The elapsed time since the unit was powered up (with 24hr roll over) is in HH:MM:SS format. The alarm status appears only if alarms are installed, it is indicated with a character string: **HiAlrm** or **LoAlrm** or **NoAlrm**.

If an error condition exists then the report will have the following format:

B_L B_LErrorString^{C_R}L_F

The ErrorString may be one of the following:

“**Error SensOpen**” or “**Error SensShort**” or “**Error SensSat**”.

In the GRAPHIC mode the instrument will transmit Epson Graphic Command compatible data strings at the selected interval. Each string has the following format:

D_{C1}E_SA⁰E_SK^{n m}.....L_FC_RE_SA⁰D_{C3}

where: DC1 selects the printer; Escape A 01 sets the advance to 1 dot per line; Escape K nmm selects the graphic mode with mmmn bytes to follow; then the graphic bytes are sent 1 byte per horizontal dot (corresponding to 1 °F or °C being plotted) where the MSbit represents the dot the other bits are not used; Line Feed & Carriage Return advance the line; Escape A 09 sets the advance to the normal 9 dots per line, DC3 deselects the printer.

In addition every 200 lines, a text line will be sent to alternately time-stamp the plot or label the extreme dewpoint axis.

This will produce a graph which looks as follows.

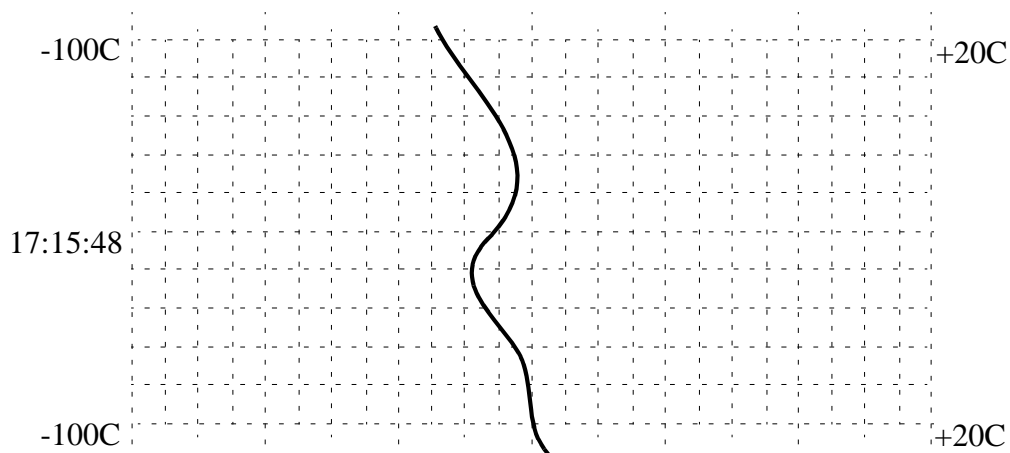

The printer should have at least 80 character columns, and it is best to use continuous form paper.

“?” command

Requests a single report of the measurement in the currently selected format.

send: ?^C_R The unit will respond in the format selected with the Data command, for example:

receive: ^B_L-59.3deg^C_P01:23:45^S_PNoAlrm^C_R^L_F

The default factory setting for the instrument is to respond in numeric format in the user chosen units. See the section about the DATA command for more details.

Serial Number Command

send: SN^C_R

receive: Ser^S_PNum^S_{Pnn}^C_R^L_F

where nn is the instrument serial number

Who Command

send: WH[O]^C_R

receive: Dev^S_PType=XDT^S_PVer=n.n^C_R^L_F

where n.n is the instrument software version

Reset Command

send: R[ESET]^S_P^C_R

the unit will perform power on reset.

Login Command

send: L[OGIN]^C_R

receive: Level^S_{P0}^C_R^L_F

Appendix L: Procedure for Exchanging XDT Sensors

To exchange sensors one must know the measured low attenuation of the sensor at some low dewpoint as well as the calibration adjustment value. These numbers can be found on the shipping container serial number label.

Through the following steps it is helpful to refer to **Appendix A: Flow Diagram of XDT Set-Up State User Interface**

1. Power up (or reset) the XDT while holding down the MODE key, in order to enter the Set-Up state. Make sure that the instrument is unlocked, refer to section 3.4.5.-10.
2. Press the MODE key to go to the **“Choose Sensor Type”** mode. Make sure that the proper sensor type is chosen, e.g. 1 (for XTR-100) or 5 (for XTR-65).
3. Press the MODE key to go to the **“Set Measured Attenuation @ low dewpoint”** mode. The display will show the currently entered attenuation in decibels (dB), this is indicated by having both the °C and °F on the display. Use the UP or DOWN keys to select the value which appears on the shipping container label. Note that this value is a negative number typically in the range of - 18.0dB to - 14.0dB.
4. Press the MODE key to go to the **“Set low dewpoint”** mode. The display will show the currently entered low dewpoint. Use the UP or DOWN keys to select the value which appears on the shipping container label.
5. Press the MODE key to go to the **“Calibration Midrange Adjust”** mode. The display will alternately show CAL and ADJ. Press the UP key once to see the entered calibration adjustment value. The display will alternately show the currently entered value and the dewpoint being measured, when showing the Cal Adj value the number (in the range of -2.0 to +2.0) will be followed by a blinking “=”, and when showing the dewpoint the display will have the appropriate legend e.g. °C. Use the UP or DOWN keys to select the value which appears on the shipping container label.
6. Press the MODE key five (5) times to go to the **“Lock or Unlock”** mode. The display will alternately show L and U. Press the DOWN key to lock the instrument. The display will alternately show only L. This prevents inadvertent changes.
7. Press the MODE key once.
8. Now the instrument has stored in it's EEPROM, the calibration values associated with the new sensor, HOWEVER NOTE THAT IT IS STILL NOT CALIBRATED. The instrument may now be reset.
9. Perform the SpanCheck Procedure in section 3.4.4.3.1.
10. Install the sensor in the sample system and measure. If for some reason the Cal Adj value must be re-entered or modified to improve accuracy the unit does not have to be SpanChecked again.

Appendix M: Uncertainty in LBS & ppmV calculations

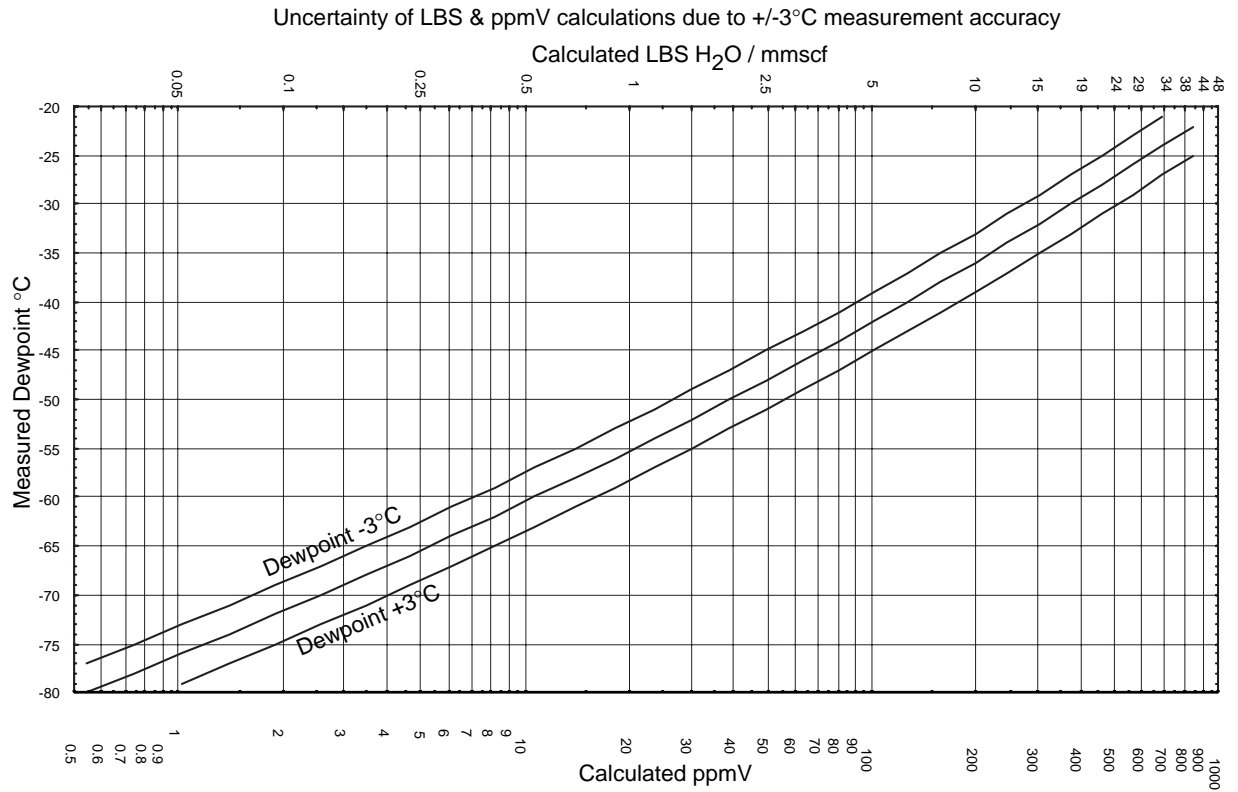

Appendix N: Certifications - Approvals - Conformity

DECLARATION OF CONFORMITY



Xentaur

We declare under our sole responsibility that the following products:
Xentaur dewpoint sensors series XTR to which this declaration relates, are in conformity with the protection requirements of Council Directive:

94/9/EC (ATEX Directive) on the approximation of the laws of the Member States concerning equipment and protective systems intended for use in potentially explosive atmospheres, and 89/336/EEC (EMC Directive) as amended by 92/31/EEC and 93/68/EEC on the approximation of the laws of the Member States relating to Electromagnetic Compatibility.

The models covered by this Declaration and evidence of conformity with the ATEX Directive are Xentaur XTR series dewpoint sensors.

Conformity to the ATEX Directive is in accordance with the following European standards.

EN 50014-1997E incl. A1+A2 Electrical Apparatus for Potentially Explosive Atmospheres - General Requirements

EN 50020-2002 Electrical Apparatus for Potentially Explosive Atmospheres - Intrinsic Safety "i"

EN 50284-1999 Special Requirements for Construction, Test and Marking of Electrical Apparatus of Equipment

Group II, Category 1 G

Certificate	Notified Body	Protection	Description
DEMKO 05 ATEX 0505798X	UL International DEMKO A/S Lyskaer 8 DK-2730 Harlev ID # 0539	EEx ia IIC, T6	Xentaur XTR series dewpoint sensors

Manufacturing Location:

Xentaur Corporation
84F Horseblock Road
Yaphank, NY 11980 USA

The authorized signatory to this declaration, on behalf of the manufacturer, and the Responsible Person is identified below.

Xentaur Corporation
84F Horseblock Road
Yaphank, NY 11980 USA

Bedros Bedrossian
Standards & Approvals Engineer,
Issue Date: 21 March 2005

Appendix N: Certifications - Approvals - Conformity (continued)

HAZARDOUS AREA
IS Class I, Division 1, Group A,B,C and D;
Class II Group E,F and G, T6 at 60 C and
ATEX EEx ia IIC T6

Intrinsically Safe Apparatus

SAFE AREA

Protective Component
Shunt-diode
Safety Barrier
See Note B

Associated Apparatus

Revisions			
Rev	Description	Date	Approved
1	updated notes	5/6/98	BB
2	added MTL755ac	11/18/98	BB
3	added 9001 zen.	6/30/99	BB
4	show sensor only	3/8/01	BB
5	ATEX markings	11/28/04	BB

Notes for installation in North America:

- Intrinsically Safe Entity Parameters: $V_{max} = 10.03Vdc$, $I_{max} = 592mA$, $C_j = 0.3\mu F$, $L_j = 0mH$.
- Selected Barriers must be galvanically isolated or dual channel shunt zener diode barriers with linear outputs, used channel to channel and having entity parameters such that $V_{oc} < V_{max}$, $I_{sc} < I_{max}$, $C_a > C_j + C_{cable}$, $L_a > L_j + L_{cable}$.
- For C_{cable} and L_{cable} , if the capacitance per foot or the inductance per foot is not known, then the following values shall be used:
 $C_{cable} = 60pF/foot$ and $L_{cable} = 0.2\mu H/foot$.
- Selected Barriers must be installed in accordance with the barrier manufacturer's control drawing and Article 504 of the National Electrical Code ANSI/NFPA 70.
- The XTR-Series sensor element does not provide 500V isolation with respect to earth.

Notes for installation in Europe:

Sensor: Xentaur XTR-series Dewpoint Sensor Element
EEx ia IIC T6 DEMKO Certificate No. 05 ATEX 0505798X

- Intrinsically safe circuit parameters: $U_j : 10.03Vdc$, $I_j : 592mA$, $C_j : 0.3\mu F$, $L_j : 0mH$.
- Selected Barriers must be galvanically isolated or dual channel shunt zener diode barriers with linear outputs used channel to channel and having entity parameters such that $U_0 < U_j$, $I_0 < I_j$, $C_0 > C_j + C_{cable}$, $L_0 > L_j + L_{cable}$.
- For C_{cable} and L_{cable} , if the capacitance per foot or the inductance per foot is not known, then the following values shall be used:
 $C_{cable} = 200pF/meter$ and $L_{cable} = 0.66\mu H/meter$.
- The wiring of the intrinsically safe circuit may be installed in accordance with EN60079-14 or according to national installation requirements.
- The XTR-Series sensor element does not provide 500V isolation with respect to earth and the leakage current is higher than 5mA. The sensor shall be connected to PE earth or installed such that it will satisfy a 500V dielectric with respect to earth.

TOLERANCES:
(unless otherwise stated)
Decimal .X = -.030
.XX = -.010
.XXX = -.005
Angular - 1 deg.
Do Not Scale Drawing.

XENTAUR Corporation
3661 HORSEBLOCK RD. MEDFORD, NY 11763
Control Drawing
for Entity Concept Approved Installation
of Xentaur XTR-series Dewpoint Sensor
connected to Associated Apparatus,
in Hazardous (Classified) Locations

Material & Finish: (see Notes) SIZE A Dwg. No. XDT.00.D.6001 Rev 5
Drawn: B.B. Scale: N/A Date: 3/5/98 Sheet 1 of 1

Xentaur Return Authorization Number Request Form

- Xentaur must approve and assign a Return Authorization Number (RAN) to any instrument being returned.
- The RAN must appear on all paperwork and packaging.
- The issuance of a RAN does not automatically imply that the instrument is covered by our warranty.
- In order to serve you better and protect our employees from any potentially hazardous contaminants Xentaur must return unopened at the senders expense all items that do not have a RAN.

To obtain a RAN fill out this form and fax to (631) 345-5349.

this document may be obtained in electronic format at www.xentaur.com and e-mailed back

Customer
Information

Company Name: _____ Address: _____
Contact Name: _____
Phone: _____
Fax: _____

Equipment
Information

Part or Model Number: _____ Serial Number: _____
Original Purchase Date: _____ PO Number: _____
Reason for Return: _____

Failure and hookup description if applicable:

Use
Information

Process material(s) and/or environments (including radiation) to which the equipment has been exposed. **An RAN will not be issued without this information.**

Certified by: Name: _____ Title: _____
Signature: _____ Date: _____

OSHA Hazard Communication Standard 29CFR 1910.1200 mandated that we take specific steps to protect our employees from exposure to potential hazards. Therefore, a letter certifying that the equipment has been decontaminated must accompany all equipment exposed to hazardous contamination.

Index

Symbols

°C	18
°F	18

A

AC power voltage	10
accuracy	
°C,°F specification	4
calculated lbs or ppmV	56
adjusting low sensor attenuation and dewpoint	26
alarms	
checking	19
present setup	19
relay contacts	10
setting	19
wiring	13
ammonia	3
analog output	
computation	50
linearity	50
load	14
range setting	27
span select 4/20mA or 0/24mA	27
testing	27
wiring	14
antistatic	9
approvals	4, 10, 57
ATEX	4
audio-visual alarm	28
Automatic Calibration	20

B

board dimensions	42
box	10
box dimensions	43, 44
buttons	16

C

cable	
access	12
compensation	28
grips	12
length	13
sensor	4
cabling	
alarm relay contacts	13
analog output	14
power	12
requirements	10
RS-232C	15
sensor	13
Cal Adj	26
calibration adjustment	26
calibration method	4
capacitance	4
CE	4, 10, 57
CENELEC	13
certifications	4, 10
changing sensors	55
checking alarms	19
chlorine	3
circuit board dimensions	42
classifications	4, 10
cleaning	31
condensation	3
connecting	
alarm relay contacts	13
analog output	14
power	12
RS-232C	15
sensor	13
container	3
contaminants	3
control drawing	13, 58
controls	10

- copper tubing6
- copyrighti
- corrosive gases3, 20
- CSA10, 13
- cUL10
- current loop
 - computations50
 - linearity50
 - load14
 - range setting27
 - span select 4/20mA or 0/24mA27
 - testing27
 - wiring14
- D**
- DC powered13
- Declaration of Conformity57
- degrees Centigrade18
- degrees Fahrenheit18
- DEMKO4
- desiccant3
- desiccant dryers5
- dewpoint range4
- diagnostic8
- dimensions10
 - circuit board42
 - enclosures43, 44
 - sensor40
- display alternate units26
- display conventions16
- DOWN button16
- E**
- electrical connections4, 10
- electromagnetic compatibility9
- EMC9
- enclosure4, 10
- enclosure dimensions43, 44
- engineering units10
- environmental seal11
- error messages4, 8, 29
- exchanging sensors55
- explosive gases3, 58
- extractive installation6
- F**
- face plate17
- fail safe operation14
- failures8, 29
- faults8, 29
- features & capabilities1
- filter7
- filter considerations48
- fittings7
- flammable gases3
- flow diagram
 - operating state37
 - self calibration38
 - set-up state39
- flow meters7
- flow range4
- flow rate7
- front panel17
- fuse29
- G**
- G/M318
- gas pressure18
- gases
 - corrosive3
 - incompatible3
- gasket7, 11
- glove boxes5
- glycol20
- grams per cubic meter18
- ground loops49
- grounding considerations49
- H**
- harsh applications21
- Hazardous Areas14, 58
- HCl3
- hermetically sealed relays14
- high pressures3
- hookup see connecting
- hydrocarbons5
- hysteresis20
- I**
- IGT Research Bulletin 818
- incompatible gases3
- in-hand micro-climate21
- in-situ installation5
- installation
 - instrument11
 - sensor4, 7
- interfacing
 - analog output14
 - RS-232C15
- intrinsically safe4, 13, 58
- isolation10
- L**
- LBS18
- liquid water3, 5, 6
- lock instrument27
- low dB26
- low dew26
- low voltage DC powered option13
- M**
- mains supply voltage10
- maintenance policyiv
- mechanical connections4
- micro-climate22
- millivolt output
 - range setting27
 - wiring14
- MODE button16
- mounting brackets11
- N**
- National Electrical Code9
- Natural Gas18
- NEC9
- NEMA11

- NFPA compliant A/V alarm28
 NIST1
 NPL1
- O**
 oil3
 operating state17
 operating state flow diagram37
 optionally ordered features/capabilities .1
 outdoor installation9
 outputs10
 overview1
- P**
 parts per million by volume18
 password protection27
 plastic tubing6
 pluggable screw terminal12
 pounds of H2O per million standard cubic
 feet18
 ppm, ppmV18
 precautions
 instrument9
 sensor3
 present setup of alarms19
 pressure5, 6
 PRESSURE CORRECT button16
 pressure correction18
 pressure operating range4
 pressure regulator7
 PSI legend18
 pure gases5
 push buttons16
- R**
 range dewpoint4
 recognitions4, 10
 relay
 contacts9, 10
 hermetically sealed14
 wiring13
 repairsiv
 repeatability4
 representativei
 resettable A/V alarm28
 resolution10
 response time4, 46
 returning equipmentiv
 RS-232C
 interfacing15
 protocol52
 rubber tubing6
- S**
 safety9
 sample flow range4
 sample treatment4
 selecting sensor type26
 self calibration flow diagram38
- sensor
 cable compensation28
 connection13
 container3
 dimensions40
 exchange procedure55
 pressure18
 signal cable4
 theory of operation45
 types26
 serial number i, 25
 setting alarms19
 setup state25
 set-up state flow diagram39
 shipping container3
 shock3, 9
 shut off valve7
 signal cable, sensor4
 single point calibration20
 SO23
 SpanCheck20, 45
 spare parts31
 specifications
 instrument10
 sensor4
 standard features/capabilities1
 static electricity9
 switches16
- T**
 technical specifications
 instrument10
 sensor4
 temperature
 instrument operating10
 instrument storage10
 sensor operating4
 sensor storage4
 terminal block12
 testing analog output27
 thread sizes7
 toxic3
 transient voltage suppressor9
 troubleshooting
 instrument29
 sensor8
 tubing6
 tygon tubing6
- U**
 UL4, 9, 10, 13
 uncertainty in LBS/ ppmV calculations 56
 units of measurement10
 unlock instrument27
 UP button16
- V**
 valve shut off7
 vibration3, 9
 voltage output
 range setting27
 wiring14

voltage, mains supply10

W

warning labels iii
warrantyiv
water3
weather proofing9
weight10
wiring9
 alarm relay contacts13
 analog output14
 power12
 requirements10
RS-232C15
sensor13

