

UPC5100/UPC5110

*Portable & Rack-mountable Pneumatic
Pressure Calibration Console*

Operation & Maintenance Manual



CONDEC 
Genuine Quality, Proven Performance.
CONDEC Sales Phone No. (888) 295-8475
CONDEC Web Site: www.4condec.com

Contents

About This Manual	1
1.0 Introduction.....	1
2.0 Operation.....	4
2.1 Pressure Cylinder Filling Procedure	4
2.2 Shop Air Operation	5
2.3 Initial Setup Procedure.....	5
2.4 Pressure Measurement Sequence (Gage Only Unit)	6
2.5 Vacuum Measurement Sequence	7
2.6 Battery Operation	8
3.0 Calibration.....	9
3.1 Pneumatic Calibration Set-up	9
3.2 Instrument Calibration Set-up	9
3.3 Zero/Span Calibration	10
3.4 Linearity and Hysteresis Calibration	11
3.5 Shunt Resistor Calibration	12
3.6 Voltage/Current Input Calibration	12
3.7 Permanent Data Storage	13
3.8 Normal Mode Test	13
4.0 Maintenance and Service.....	14
4.1 Troubleshooting	14
4.2 Maintenance and Service Procedures	14
4.2.1 UPC5100/UPC5110 Panel/Chassis - Removal and Installation	14
4.2.2 Nitrogen Cylinder Assembly (PN 59531) - Removal and Installation	15
4.2.3 ORION-2D Manifold Removal (PN 55286).....	16
4.2.4 ORION-2D Manifold - Valve Seat Removal	16
4.2.5 ORION-2D Manifold - Vernier Control Disassembly	17
4.2.6 ORION-2D Manifold - Vernier Control Reassembly	17
4.2.7 ORION-2C Manifold - Valve Seat Installation	18
4.2.8 ORION-2D Manifold - Panel Installation	19
4.2.9 ORION-2D Manifold - Valve Adjustment Procedure	19
4.2.10 Chassis Mounted Regulator (PN 55502) - Removal, Installation and Adjustment	21
4.2.11 Pressure Limit Control (PN 58409) - Regulator Removal and Installation	22
4.2.12 Supply Pressure (PN 59730) and Pressure Limit Monitor (PN 59706) Gauges-Removal and Installation	23
4.2.13 Test Port Quick-Connect Fitting (PN 59762) - Removal and Installation	23
4.2.14 Test Port Filter (PN 54188) - Removal, Cleaning and Installation	24
4.2.15 Vacuum Generator - Removal, Cleaning and Installation	24
4.2.16 Vacuum Control Regulator (PN 59765) - Removal, Installation and Adjustment	26
4.2.17 Inlet Check Valve, Nitrogen Fill Port (PN 60263) - Removal, Disassembly and Installation	27
4.2.18 AC Fuse (PN 58076) - Removal and Installation	27
4.2.19 AC Power/EMI Line Filter (PN 58870) - Removal and Installation	28
4.2.20 Power Switch (PN 55187) for Battery Units - Removal and Installation	28
4.2.21 Power Switch (PN 58878) for Non-Battery Units - Removal and Installation	29
4.2.22 Range Select (PN 54186) and Display Select Switches (PN 59429) - Removal and Installation	29
4.2.23 Zero Switch (PN 58886) - Removal and Installation	30
4.2.24 Power Supply Assembly (Battery Units Only) - Removal and Installation	31
4.2.25 BATTERY (Replacement Kit PN 55354) - Removal, Installation and Adjustments	31
4.3 Orion-2D Valve Assembly Component Parts List	33

5.0	Model Number System	36
6.0	Available Ranges, Conversions and Resolutions	37
7.0	Options - Replacement Kits	38
8.0	Specifications	39
	UPC5100/UPC5110 Warranty and Return Policy	51
	UPC5100/UPC5110 Return Material Authorization Form.....	52

About This Manual

This manual is intended for use by service technicians responsible for installing and servicing the UPC5100/UPC5110 pneumatic pressure console.

The UPC5100 portable pneumatic pressure calibrator and the rack-mounted UPC5110 are rugged, compact instruments manufactured by Condec. They are designed to provide superior accuracy, range of calibration and ease of operation when used for the calibration of a wide variety of pressure sensing and measuring devices.

These instruments utilize a repeatable sensor coupled to microprocessor-based electronic circuitry and a selectable unit display system. This provides an easy-to-read and accurate digital representation of the measured pressure. This all electro-mechanical device combines a 7 cu. ft., 2216 PSI cylinder with our precision ORION-2D vernier. The unit has one test port and front panel gauges that indicate system pressure and remaining pressure in the internal cylinder. A pressure regulator acts as a pressure limiter so that the operator can not over-pressurize a unit under test. Fill and test hoses are supplied for the customer. Standard front panel buttons and switches provide selection of the desired mode, (pressure or vacuum), pressure range, push-button zeroing and internal self-check feature. This manual has been written to give the user a simple and clear explanation of how to operate, calibrate, and maintain these instruments.



Caution Before attempting to use either style pressure calibrator, the following instructions must be carefully read and understood by personnel using the equipment. This is a high-pressure system. It is strongly recommended that only personnel formally trained in the use of pneumatic pressure equipment be permitted to operate it. Potentially dangerous conditions can be produced through negligent handling or operation of the console due to the high pressure cylinder contained within the unit.

These units are strictly for use with pneumatic pressures. Erroneous readings and potential damage can result from the introduction of hydraulic fluids into the internal tubing lines.



Authorized distributors and their employees can view or download this manual from the Condec distributor site at www.4condec.com.

1.0 Introduction

Utilizing microprocessor technology, the UPC5100 and rack-mounted UPC5110 instruments offer a combination of features, performance, versatility, and reliability not previously available in a single, self-contained pressure calibration instrument. Some of the features are listed below:

- Independent switch-selectable pressure ranges.
- Accuracy of each range equal to or better than $\pm 0.05\%$ full scale.
- Both pressure and vacuum calibrations available via front panel switch selection.
- Automatic self-check: Computer-controlled internal circuitry provides automatic maintenance of both zero and span calibration data to ensure long-term stability and accuracy.
- Digital Display: Large LED digits provide excellent readability under all lighting conditions (also available with a Liquid Crystal Display).
- Using a manually adjustable regulator, the maximum system input pressure is adjusted to any value higher (typically 20 to 50%) than the full scale range of the device being tested and, the unit under test is fully protected from being inadvertently over-pressurized.
- Portable: These compact, self-contained systems are easily carried and operated by only one person. Total weight is less than 40 pounds.

- **System Calibration:** The instruments can be completely calibrated without being removed from the external case. A separate plug-in Condec Calibration Module (PN 60109) provides access to the computer when calibration is performed. No manual alignment or potentiometer adjustments are required.
- **Calibration Integrity:** Once calibrated, the tamper-proof design provides numerous safeguards that guarantee the integrity of pressure readings obtained. The LED provides the operator with status information during both operation and calibration.
- **Pressure Source:** An internal supply cylinder with a volume of 7.0 std. cu. ft. of N₂ provides up to 2015 PSIG of pressure for calibration and test. A quick-disconnect fitting with a check valve provides re-charging capability.
- **Simple Operation:** All controls, indicators and pressure ports are accessible from the front panel. Section 2 provides clear, concise instructions for system operation.
- **Data Input Capability:** A front panel-mounted connector and selector switch permit the 4-20 mA current signal from the gage-under-test or voltage to be displayed. Transducer excitation voltage of 18 VDC is provided as a standard feature.
- **Safe, Clean Operation:** All pressure components are made of brass, copper, aluminum or stainless steel and proof-tested to at least 150% of maximum operating pressure. In addition, the system contains a high-pressure burst disk and relief valves to protect both the operator and system components from harm in the event of over-pressurization.

The heart of this calibration system is a highly stable and repeatable pressure transducer. These sensors produce an electrical output signal which is linearly proportional to the applied pressure.

By combining these sensors with microprocessor-based circuitry, an even higher degree of operational accuracy and precision has been accomplished. For example, computer-generated correction curves for both the non-linearity and the hysteresis of the sensors improve these characteristics by an order of magnitude or more. In addition, a self-check feature ensures long-term accuracy by utilizing the computer to generate and control an internal shunt calibration mode of operation. The indicators full-scale reading is compared against, and if necessary, corrected to the digitally-stored value for full scale obtained at the time of initial pressure calibration.

The computer is programmed with a series of internal self-diagnostic routines that continually monitor and check every bit of data stored and processed by this system. The system either notes or shuts down operation in the event of an out-of-tolerance reading or outright failure.

The UPC5100 has an internal, rechargeable 12 volt lead acid battery, that provides a minimum of six hours of complete portability when fully charged. An ON/OFF and battery test switch is provided to conserve energy when the instrument is not in use and to provide the operator with battery voltage status during use. It also has a LO BATT indicator on display.

The following schematic provides an overview of the UPC5100/UPC5110's function.

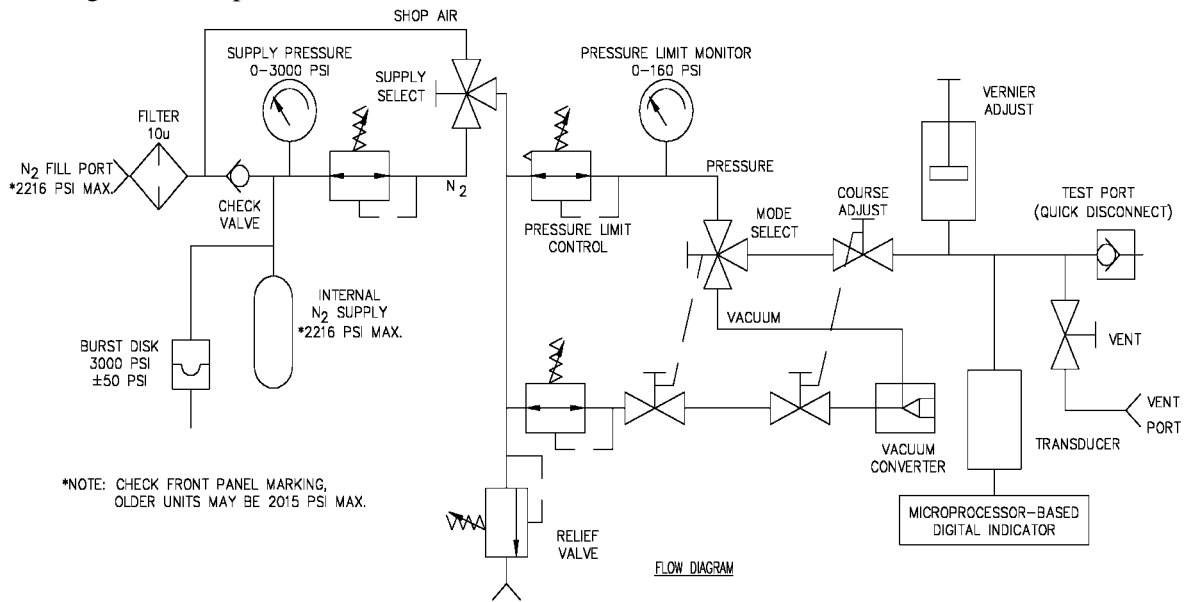

Figure 1-1. UPC5100/UPC5110 Flow Diagram

2.0 Operation

The following sections explain the various procedures for operating the UPC5100/UPC5110.

2.1 Pressure Cylinder Filling Procedure

To initially fill or refill the internal pressure cylinder (2015 PSI max) of the UPC5100/UPC5110, see Figure 2-1 and proceed by following these steps:

NOTE: Check the Nitrogen Fill Port markings on Pressure Console, some units may be 2216 PSI max.

1. Close **PRESSURE LIMIT CONTROL** (1) by pulling regulator knob outward and turning counter-clockwise. When closed, push knob inward. Close the **COARSE ADJUSTMENT** valve (2) by rotating clockwise until it stops.
2. Connect the fill hose (3), to a clean regulated nitrogen source (5).
3. Connect the other end of the fill hose (3) to the male fill port fitting (4).
4. Slowly open the valve on the nitrogen source and allow the gas to flow into the pressure cylinder. The **SUPPLY PRESSURE** gauge (6) indicates the amount of pressure within the internal cylinder.

NOTE: The Inlet Check Valve (PN 60263) and the Nitrogen Fill Port (Section 4.2.17 on page 32; Figure 4-4 on page 41) can be damaged if pressure is released too fast.

5. Use the following procedure for filling the cylinder:
 - a) Fill cylinder to 1000 PSI at a rate of charge equal to a minimum of two minutes, then wait five minutes for system to stabilize.
 - b) Fill cylinder from 1000 PSI to maximum pressure at a rate of charge equal to a minimum of two minutes.
 - c) Wait five minutes for system to stabilize before using.

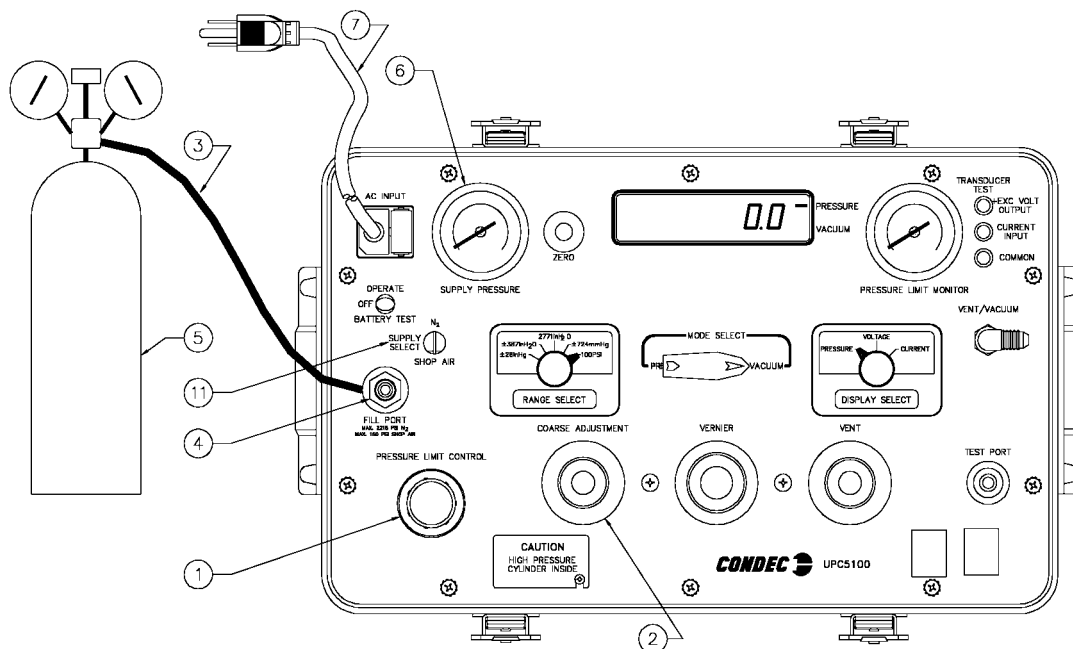

Figure 2-1. Pressure Cylinder Fill Procedure

NOTE: UPC5100 shown, AC Input (7) and Fill Port (4) are on back of UPC5110 Rack Mountable Calibrator.

2.2 Shop Air Operation

1. Turn the *SUPPLY SELECT* valve (7) to the *SHOP AIR* position and connect a shop air hose to the male fill port (4). Maximum input pressure is 150 PSI.

2.3 Initial Setup Procedure

To prepare for actual calibration usage, see Figure 2-2 below and proceed as follows:

1. Check that the *COARSE ADJUSTMENT* valve (2) is closed (rotate clockwise until it stops) and that the *VENT* valve (8) is open (two turns counter-clockwise from its stop).
2. Plug in the power cord (7) and energize the unit by flipping the power switch (18) to *OPERATE*. The UPC5100/UPC5110 will perform an internal functional self-check. If acceptable, a 100.00 flashes briefly and the display returns to a normal reading. Allow at least ten minutes warm-up time. Select the desired full scale pressure range via the five-position *RANGE SELECT* rotary switch (19). For the best accuracy, the selected range must be greater, but close as possible to, the full scale range of the device under test.

NOTE: Do not switch pressure ranges during a calibration cycle.

3. Set the *DISPLAY SELECT* switch (16) to the *PRESSURE* position.
4. Connect the male end of the test hose to the *TEST PORT* (17) fitting.
5. Connect the swivel fitting end (7/16-20) of the test (output) hose to the device-under-test (use adapters if required). Tighten all connections properly.

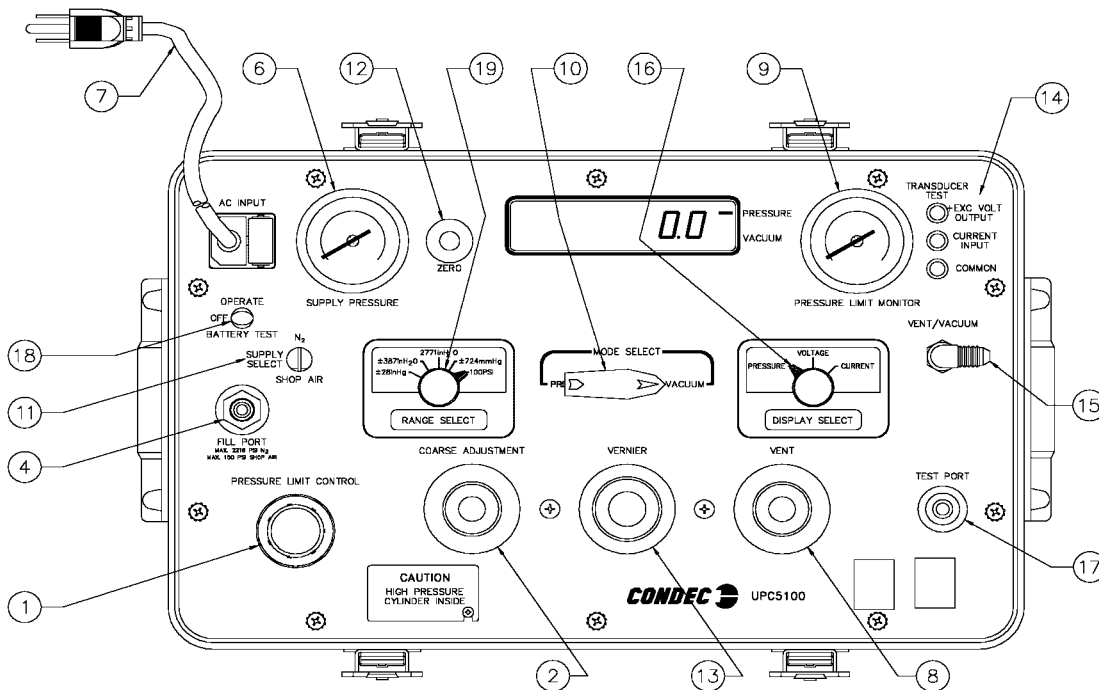

Figure 2-2. Initial Setup Procedure

NOTE: UPC5100 shown, AC input (7) and fill port (4) are on back side of UPC5110 Rack Mountable Calibrator.

6. Optional - if the current (4.0000 to 20.0000 mA) measurement features are used, connect the provided transducer test cable (PN 55092), to the transducer test jacks (14).

When connected, the transducer test cable provides +32 VDC excitation on non-battery units, or +18 VDC excitation on battery units. The internal impedance (load) is 10 ohms.

NOTE: The +excitation voltage is only available 110-120 VAC operation.

The display scaling for these current measurements are as follows:

SWITCH POSITION	DISPLAY READING
Current	0-20.000 mA by 0.005 mA
*Voltage	0-100.00 mV by 0.02 mV

Table 2-1. Display Select Switch (16)

NOTE: UPC5100/UPC5110 reads a 4-20 mA signal only, but will display as either 4-20 mA or 20-100 mV.

The test cable connector wiring is as follows:

CONNECTOR PIN DESIGNATION	FUNCTION
A	+ VDC
B	+ SIGNAL
C	NOT USED
D	VOLTAGE & SIGNAL COMMON

Table 2-2. Transducer Test Cable (PN 55092)

NOTE: Connector pin designations are for reference only, and are no longer a connector on newer units. See Figure 2-2 on page 5 (14).

2.4 Pressure Measurement Sequence (Gage Only Unit)

NOTE: See Figure 2-3 on page 5 when following these steps:

1. Turn the *MODE SELECT* valve (10) to the *PRESSURE* position.
2. Close the *COARSE ADJUSTMENT* valve (2), clockwise, and open the *VENT* valve (8), counter-clockwise.
3. Using the *PRESSURE LIMIT CONTROL* regulator (1), (pull knob outward while adjusting) adjust the maximum system input pressure (as read by the *PRESSURE LIMIT MONITOR* [9]), to any desired value higher (typically 20-50% higher) than the full-scale range of the device under test. Using this technique, the device under test is fully protected from being accidentally over-pressurized.
4. Zero unit by momentarily depressing the *ZERO* switch (12) for less than five seconds.

NOTE: The instrument can be zeroed at any time, as long as the *VENT* valve (8) is open, by momentarily depressing the *ZERO* switch (12) for less than five seconds.

5. To apply pressure, close the *VENT* valve (8), approximately two turns clockwise, until it stops, then open the *COARSE ADJUSTMENT* valve (2) approximately 1/2 turn counter-clockwise until the numerical display begins to move. The operator may change the pressure rapidly until reaching approximately 90% of the desired final value.
6. Use either the *COARSE ADJUSTMENT* (2) or *VENT* valve (8) to obtain a specific pressure reading. Both provide precise control. As the pressure approaches the desired value, the valve being used for control should be rotated slowly clockwise to its closed position.
7. To obtain exact pressure readings, slowly rotate the *VERNIER* control (13) knob in the direction required (clockwise to increase pressure) as indicated by the electronic numerical display.
8. The transducer current measurement can be displayed at any time by placing the *DISPLAY SELECT* switch (16) in its *CURRENT* position.

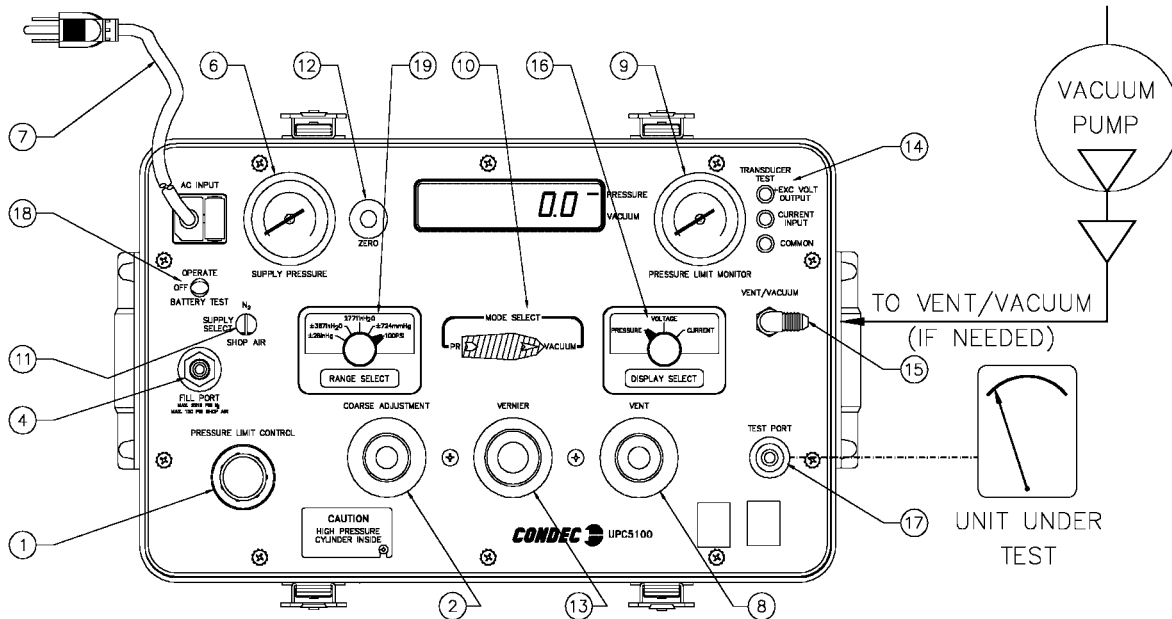

Figure 2-3. Pressure or Vacuum Measurement Sequence

NOTE: UPC5100 shown, AC Input (7) and Fill Port (4) are on back side of UPC5110 Rack Mountable Calibrator.

2.5 Vacuum Measurement Sequence

See Figure 2-3 above and proceed as follows:

1. Turn the *MODE SELECT* valve (10) to the *VACUUM* position.
2. Close the *COARSE ADJUSTMENT* valve (2) clockwise and open the *VENT* valve (8), counter-clockwise.
3. Zero the unit by pressing the *ZERO* button (12).
4. If only pressure measurements greater than atmospheric pressure are required continue to step 4.1. If simultaneous pressure measurements above and below atmospheric pressure, or if a vacuum level higher than 27" Hg are required, go to step 5.
 - 4.1 Close the *VENT* valve (8) (approximately two turns to its stop) and open the *COARSE ADJUSTMENT* valve (2) slowly by rotating knob counter-clockwise until the numerical display begins to move. It will immediately activate the vacuum converter. A vacuum as low as 27" Hg can be maintained in the system without the use of an external vacuum pump. In general, the pressure may be changed rapidly until reaching approximately 90% of its desired final value. Closing the *COARSE ADJUSTMENT* valve (2), clockwise will deactivate the vacuum converter and trap the vacuum in the system.
- NOTE: The vacuum may be vented by opening *VENT* valve counter-clockwise or switching the *MODE SELECT* to the *PRESSURE* position and opening the *COARSE ADJUSTMENT* valve counter-clockwise.
 - 4.2 Use the *COARSE ADJUSTMENT* (2) and *VENT* valve (8) to obtain a specific pressure reading. Both provide precise control. As the pressure approaches the desired value, the valve being used for control should be rotated slowly clockwise to its closed position.
 - 4.3 To obtain exact pressure readings, slowly rotate the *VERNIER* control (13) knob in the direction required (counter-clockwise to increase vacuum) as indicated by the electronic numerical display.
5. If simultaneous pressure measurements above and below atmospheric pressure are required, or if a vacuum level higher than 27" Hg are required, connect a vacuum pump to the *VACUUM/VENT* port (15) as shown in Figure 2-3 on page 7.
6. Open the *VENT* valve (8). Close the *COARSE ADJUSTMENT* valve (2) and apply power to the vacuum pump and allow it to evacuate the system for several minutes or until the digital display reading reaches equilibrium near zero PSIA. Press the *ZERO* button to establish a zero reference on the display.

7. With the vacuum pump still running, close the VENT valve (8) and check for system leaks. If there are none, continue to step 7.1
 - 7.1 To apply pressure, close the VENT valve (8) (approximately two turns to its stop) and open the COARSE ADJUSTMENT valve (2) (approximately 1/2 turn counter-clockwise until the numerical display begins to move). In general, the pressure may be changed rapidly until reaching approximately 90% of its desired final value.
 - 7.2 Use either the COARSE ADJUSTMENT (2) or VENT valve (8) to obtain a specific pressure reading. Both provide precise control. As the pressure approaches the desired value, the valve being used for control should be rotated slowly clockwise to its closed position.
 - 7.3 To obtain exact pressure readings, slowly rotate the VERNIER control (13) knob in the direction required (clockwise to increase pressure) as indicated by the electronic numerical display.

2.6 Battery Operation

When supplied with the battery, the UPC5100/UPC5110 has an internal, rechargeable 12 volt, lead acid battery which provides a minimum of six hours of completely portable usage before having to be recharged.

An ON/OFF/BATTERY TEST switch (18) (Figure 2-3 on page 7) is provided to conserve energy when the instrument is not in use, and to provide the operator with information as to the status of the battery voltage during use.

The UPC5100/UPC5110 can be operated and recharged by connecting to a standard AC outlet via the line cord (supplied). The battery re-charge cycle time is approximately 16 to 20 hours with the ON/OFF switch in the OFF position. The charging circuit is designed to be left on indefinitely without adversely affecting battery life.

When selected, the momentary action BATTERY TEST switch (18) is used to read the actual battery voltage. The battery voltage reading typically is between 11.5 and 13.0 volts. When the battery voltage reads 11.5 volts, there are approximately one to two hours of useful operation left and a low battery indicator is illuminated. For LED display units, a LED in the left center of the display turns on. For LCD display units, five LED segments in the left of the display window illuminate in a “U” shape. The instrument ceases to function when the battery voltage is 11.0 volts or less.

NOTE: The battery test should only be performed with the UPC5100/UPC5110 operating at zero PSIG (VENT valve open) and at the conclusion of the test, the unit's ZERO button will have to be pushed again to re-zero the instrument.

3.0 Calibration

Follow the procedure on the following pages for calibrating the UPC5100/UPC5110.

NOTES:

- When calibrating, the computer within the UPC5100/UPC5110 is actually being re-programmed, therefore it is important that the pressure standard being used is in satisfactory operating condition and that the technician fully understands its operating characteristics and methods of usage. In addition, the UPC5100/UPC5110 itself must be properly warmed up (approximately thirty minutes) and electrically stabilized prior to performing a calibration cycle.
- The CONDEC Repair Lab is equipped to do calibrations on CONDEC calibrators and pressure standards. Calibrations include a certification and are traceable to N.I.S.T (see "UPC5100/UPC5110 Return Material Authorization Form" on page 52).

3.1 Pneumatic Calibration Set-up

Figure 3-1 defines a typical calibration set-up using a floating piston-type, air dead weight tester and a vacuum dead weight tester. A vacuum pump will be required to enable calibrating the -14 PSIG of the Bi-directional ranges.

NOTE: Any type of precision standard is acceptable as long as its basic accuracy is $\pm 0.025\%$ of point or better.

To permit proper calibration, at least an ON/OFF and a VENT valve (connected as shown in Figure 3-1) must be provided.

3.2 Instrument Calibration Set-up

The UPC5100/UPC5110 is placed into its calibrate mode by connecting a Condec Calibration Module (PN 60109) via the multi-pin jack. The jack is located behind the small slide plate near the fill port (see Figure 3-1).

The Condec Calibration Module provides access to the calibrator's various program modes via a five-position rotary switch. It also provides a means of entering and storing data via four other momentary action switches.

In the calibrate mode, the UPC5100/UPC5110's numerical display is used to provide operator prompting symbols as well as displaying the various data formats. For example, in Figure 3-2, the data format shown is that obtained as soon as the ZERO/SPAN position of the rotary switch is selected.

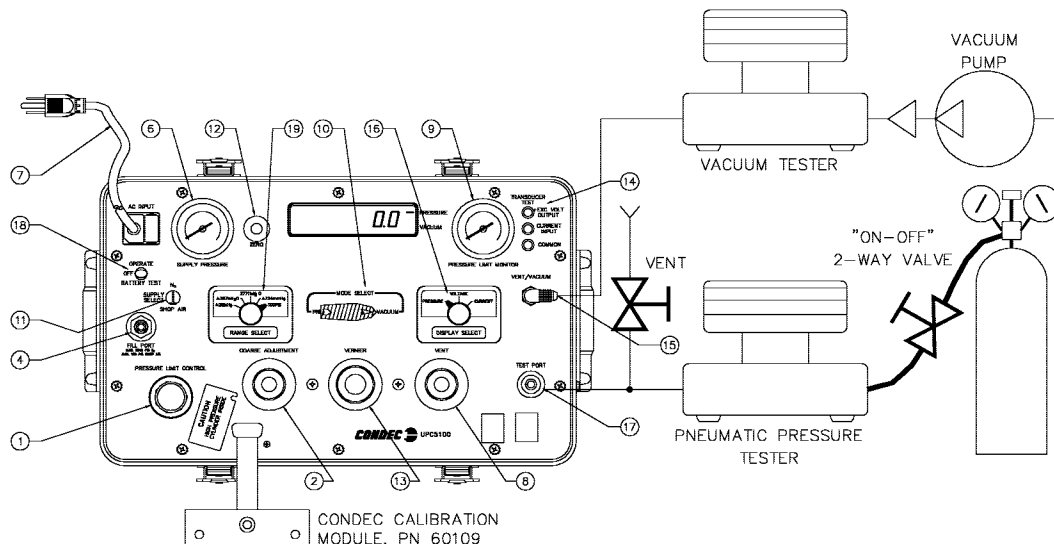

Figure 3-1. Instrument Calibration Set-up

NOTE: UPC5100 shown, AC input and Fill Port are on backside of UPC5110 Rack Mountable Calibrator.

3.3 Zero/Span Calibration

Selecting the ZERO/SPAN position on the Condec Calibration Module (PN 60109) places the instrument into its ZERO/SPAN calibration mode. The display is shown in Figure 3-2.

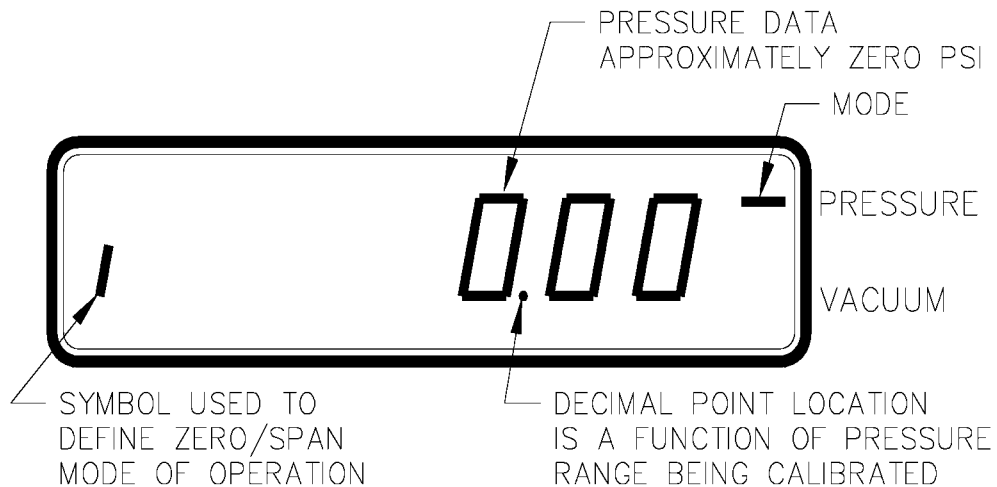

Figure 3-2. Zero/Span calibration for Gage-Only Units

The unit needs to be calibrated to only one positive and one bi-directional range. All bi-directional ranges are calibrated over 0 to +14 PSI and 0 to -14 PSI. All the positive ranges from 0 to 100 PSI. Starting with one of the instrument's ranges, perform the steps shown in Table 3-1. Perform the following for each step:

1. Adjust input pressure to the appropriate (either 0 or full-scale) value.
2. Perform the action indicated in Table 3-1 when pressure input readings are stable.

NOTE: A vacuum pump will be required to enable calibrating the -14 PSI of the bi-directional ranges.

Step No.	Pressure Input Value	Operator Action Required	Resulting Calibration Standard Display Indication			Remarks
	(For Bi-directional range)		+/-30" Hg	+/-400" H ₂ O	+/-100 kPa	
1	0 PSI	Press ENTER button	0.000	0.000	0.000	Note 1 below
2	+14 PSI	Press ENTER button	28.505	387.95	96.52	Notes 2 & 3 below
3	0 PSI	Press ENTER button	0.000	0.000	0.000	Note 1 below
4	-14 PSI	Press ENTER button	-28.505	-387.95	-96.52	Notes 2 & 3 below
Step No.	(For positive direction range)	Operator Action Required	100 PSI	2700" H ₂ O	—	Remarks
1	0 PSI	Press ENTER button	0.00	0.00		Note 1 below
2	100 PSI	Press ENTER button	100.00	2771.0		Notes 2 & 3 below

Table 3-1. Zero and Span Calibration Sequence

NOTES:

1. If readings are not stable or are not within $\pm 20\%$ of zero, the zero correction can't be entered.
2. If readings are not stable or are not within $\pm 5\%$ of 100%, the span correction cannot be entered.
3. For ease of calibration, do the Linearity/Hysteresis calibration, prior to doing ZERO/SPAN of next range.

3.4 Linearity and Hysteresis Calibration

Install the Condec Calibration Module (PN 60109) and select the LYN/HYS position of the rotary switch on the module. This places the UPC5100/UPC5110 into its linearization/hysteresis calibration mode. The display is shown in Figure 3-3 below.

NOTE: The zero/span calibration needs to be performed prior to linearity and hysteresis calibration.

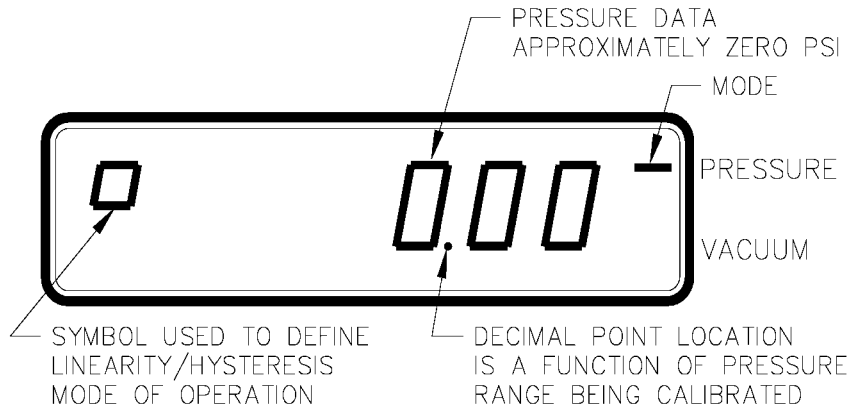

Figure 3-3. Linearity and Hysteresis Calibration

Sequentially perform the thirteen steps described in Table 3-2, for each pressure range being calibrated. Perform the following for each step:

1. Adjust input pressure to the appropriate value without overshooting the setting. If value is overshoot, vent unit and repeat steps.
2. Perform the action as indicated when the readings are stable, 1 to 2 minutes. If it is taking longer, check system for leaks. If no leaks are found, the CPU or transducer may be defective.

Step	Input Pressure % of Range	CONDEC Calibration Module Operator Action Required	UPC5100/UPC5110 Display Status Symbol in Left-most Digit	Remarks
1	0	Press ZERO switch	Upper Circle	Zero on display
2	10	Press ENTER button	Upper Circle	Notes 1 & 2 below
3	20	Press ENTER button	Upper Circle	Notes 1 & 2 below
4	30	Press ENTER button	Upper Circle	Notes 1 & 2 below
5	40	Press ENTER button	Upper Circle	Notes 1 & 2 below
6	50	Press ENTER button	Upper Circle	Notes 1 & 2 below
7	60	Press ENTER button	Upper Circle	Notes 1 & 2 below
8	70	Press ENTER button	Upper Circle	Notes 1 & 2 below
9	80	Press ENTER button	Upper Circle	Notes 1 & 2 below
10	90	Press ENTER button	Upper Circle	Notes 1 & 2 below

Table 3-2. Linearization and Hysteresis Calibration Sequence

Step	Input Pressure % of Range	CONDEC Calibration Module Operator Action Required	UPC5100/UPC5110 Display Status Symbol in Left-most Digit	Remarks
11	100	No Action Required	Lower Circle	Note 3 below
12	50	Press ENTER button	Lower Circle	Notes 1 & 2 below
13	0	No Action Required	Upper Circle	

Table 3-2. Linearization and Hysteresis Calibration Sequence (Continued)

When Step 11 is reached, the display changes so that the left most status symbol is a lower circle. This remains for Step 12 and down to approximately 0.00 PSI.

NOTES:

1. If reading is in motion or correction required is not within $\pm 0.8\%$ of full-scale, no entry is made.
2. If entry is valid, the display momentarily indicates the correction value (in percent) and the memory location at which it is stored.
3. If 100% ($\pm 0.05\%$) is not obtained, repeat the zero/span calibration sequence.

3.5 Shunt Resistor Calibration

To place the UPC5100/UPC5110 into shunt calibration mode, install the Condec Calibration Module (PN 60109) and select the SHUNT MODE position of the rotary switch. The display is shown in Figure 3-4.

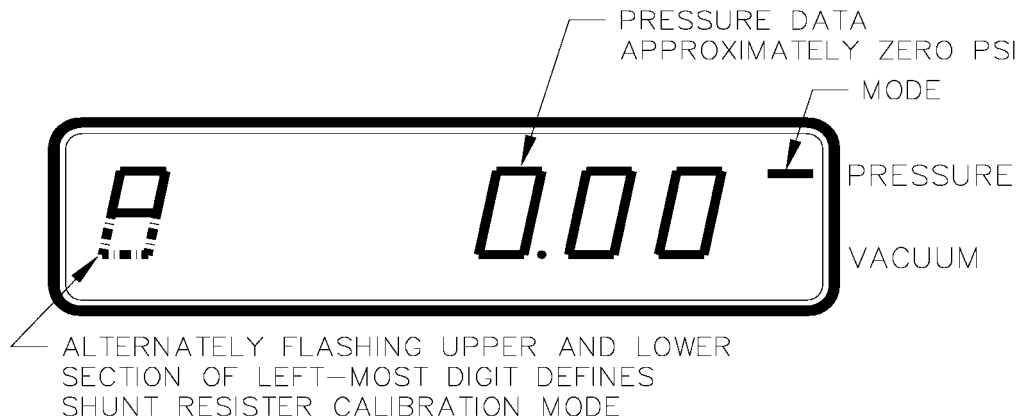

Figure 3-4. Display in Shunt Resistor Calibration Mode.

Perform the four step sequence on the UPC5100/UPC5110 as described below.

1. Be sure the input pressure is set at 0 PSIG.
2. Press and hold the ZERO button on the module until a stable zero indication is obtained.
3. Release the ZERO button and allow the display to stabilize at its shunt resistor calibration number ($100 \pm 5.00\%$).
4. Press the ENTER button on the module. When accepted, the bottom half of all display digits momentarily illuminate.

3.6 Voltage/Current Input Calibration

To calibrate unit, a current generator capable of generating 20 mA, must be connected to the COMMON and CURRENT INPUT jacks (Figure 2-3 on page 7 [14]). The DISPLAY SELECT switch (16) should be in the VOLTAGE position.

1. Set the Condec Calibration Module (PN 60109) to the ZERO/SPAN position (see Figure 3-2 on page 10 for display reading).

2. Press the ENTER button on the module. The display reads *0.00*.
3. Set the current generator for 20 mA output. Press the ENTER button on the module. The display should read *100.000*.
4. Turn the DISPLAY SELECT switch (16) to the CURRENT position. Display will read *20.000*.
5. Disconnect the current generator.

NOTE: If the display reading is off, set the Current Generator to 0, and press the ENTER button on the Condec Calibration Module. Set the Current Generator for 20 mA output. The display will read 20.000. If the display reading is off, press the ENTER button on the module. If the display reading is not 20.000, CPU is faulty and requires servicing.

3.7 Permanent Data Storage

After completing the above calibration procedures, the new data that has been entered into the computer must be permanently stored. The sequence to do this is as follows:

1. Select the DATA RECALL position of the rotary switch on the Condec Calibration Module (PN 60109).
2. Press the STORE button on the module.
3. When the data is accepted, the four-digit number on the display indicates *1 020* for as long as the STORE button is pressed.

3.8 Normal Mode Test

After completing the above calibration procedures, you must perform a normal mode test.

1. Set the Condec Calibration Module to the NORMAL MODE position.
2. DISPLAY SELECT switch should still be in the CURRENT position. Display will read *20.000*.
3. Turn the DISPLAY SELECT switch to the VOLTAGE position. Display will read *100.00*.
4. The pneumatic portion of the calibration is now complete and the pressure standard and the module can now be disconnected.

4.0 Maintenance and Service

This section outlines the mechanical and basic electrical repair procedures for the UPC5100/UPC5110.

4.1 Troubleshooting

Use Table 4-1 below for information on troubleshooting the UPC5100/UPC5110.

Symptom	Problem	Remedy
No lit display	Unit will not energize	Check fuse, check power source, check power switch
Display slowly decreases over time	Leak in system	Check all compression and pipe fittings with snoop, bottle of liquid leak gas detector (PN 64781)
Display does not respond when Vernier knob is turned	No Vernier control	Readjust isolation valves on Orion; replace O-ring on Vernier piston
Display increases or decreases when COARSE (Pressure) or VENT valves are closed	No Pressure or Vent control	Replace valve seats or O-rings in valves; check valve needles
Unit will not stay in CAL; display shows "o" and reads a high value at zero PSIG.	Transducer over-pressurized	Replace transducer
Low battery indicator on display illuminates when unit is powered	Low or no battery power	Re-charge battery, check power supply charging voltage
No display when in battery mode after charging	Battery will not hold charge	Replace battery
Display will not zero	Display will not zero	Perform a ZERO/SPAN calibration
Display shifts	Transducer drifts or possible over pressure	Replace transducer
Gas escapes when external supply pressure is bled	Nitrogen cylinder will not remain charged	Remove inlet check valve; clean or replace

Table 4-1. UPC5100/UPC5110 Troubleshooting

4.2 Maintenance and Service Procedures

The repair procedures cover the major components and sub-assemblies which are critical to the proper functioning of the calibrators and may need periodic maintenance over the life of the unit.



Caution

Only those persons who are formally trained as skilled technicians should attempt to repair these units. Although some mechanical sub-assemblies could be replaced without venting cylinder it is not recommended. All safety precautions should be observed due to the presence of electrical components and high-pressure cylinders. Unit must always be unplugged from power source.

4.2.1 UPC5100/UPC5110 Panel/Chassis - Removal and Installation

Tools required: Phillips screwdriver

UPC5100 Removal:

1. Verify that power toggle switch is in the OFF position. Loosen and remove the eight screws (PN 14862) that secure the panel assembly to the enclosure.
2. Lift the panel and chassis by grasping the fill port fitting and vent/vacuum port. Then grasp under the panel edges. Ensure that the wire harnesses do not catch and snag.
3. Gently set the panel/chassis assembly on a bench top. It can be rested on the panel bottom and pressure cylinder, with the panel tilted at an angle from its vertical.

UPC5100 Installation:

1. Lift the panel and chassis by first grasping the fill port fitting and test port.
2. Gently place panel/chassis assembly into enclosure. Ensure that the wire harnesses do not catch and snag.
3. Align mounting holes and install the eight screws (PN 14862) that secure the panel assembly to the enclosure.

UPC5110 Removal:

1. Verify that power toggle switch is in the OFF position. Loosen and remove the fourteen screws (PN 14862) from top, bottom, and sides that secure the panel assembly to the enclosure.
2. Lift the panel and chassis by grasping the handles located on the front of the rack mountable panel. Ensure that the wire harnesses do not catch and snag.
3. Gently set the panel/chassis assembly on a bench top. It can be rested on the panel bottom and pressure cylinder, with the panel tilted at an angle from its vertical.

UPC5110 Installation:

1. Lift the panel and chassis by grasping the handles located on the front of the rack-mountable panel.
2. Gently place panel/chassis assembly into enclosure. Ensure that the wire harnesses do not catch and snag.
3. Align mounting holes and install fourteen screws (PN 14862) from top, bottom, and sides that secure the panel/chassis assembly to the enclosure.

4.2.2 Nitrogen Cylinder Assembly (PN 59531) - Removal and Installation

NOTE: Condec strongly recommends that the internal nitrogen supply cylinder be pressure-tested and re-certified every five years from date cylinder was manufactured per U.S. DOT. 3AL Regulation, Title 49 CFR, parts 173 and 178.

Tools required:

- 7/16" open end wrench
- Flat bladed screwdriver
- 1-1/8" open end wrench
- 3/8" open end wrench
- A/R 1/4"-wide Teflon tape (PN 60575)
- A/R 1/2"-wide Teflon tape (PN 60911)
- tube of fluorinated grease (PN 55593)
- snoop, bottle of liquid gas leak detector (PN 64781)

Removal:

1. Vent any remaining nitrogen from cylinder to atmosphere. Disconnect power cord from power source.
2. Remove front panel from its enclosure as described in Section 4.2.1 and carefully set on a bench top.
3. Using a 7/16" wrench, remove all tubing sections from the cylinder.
4. Loosen the two mounting clamps from around the cylinder.
5. Remove the cylinder assembly.
6. If installing a new cylinder, remove the fitting/tee assembly and Teflon seal ring and inspect for any damage. If no damage is present these items may be used in the new cylinder.

Installation:

1. Install the Teflon ring seal (PN 59217), fitting (PN 59287), and branch tee (PN 59750) on the new cylinder and tighten until snug. Prior to installation wrap two layers of Teflon tape on the pipe threads of branch tee fitting. Also, place a small amount of Krytox grease on both sides of Teflon ring seal prior to installation.
2. Mount the cylinder in the chassis making sure that the tee fitting is correctly oriented to accept tubing sections and cylinder nameplate is legible.
3. Tighten the two clamps (PN 55250).
4. Install the tubing sections, tightening all fitting nuts 1/4 turn from finger-tight using a 7/16" wrench.
5. Fill the cylinder to approximately 1000 PSIG and check all fittings for leaks. If there are no leaks fill nitrogen supply cylinder to maximum pressure. See Section 2.1 on page 4 for cylinder refilling procedure.
6. Install panel/chassis assembly in its enclosure as described in Section 4.2.1 on page 14.

4.2.3 ORION-2D Manifold Removal (PN 55286)

Tools required: Phillips screwdriver
11/32" wrench or nutdriver
.061" hex wrench
adjusting screwdriver (small flat blade)
11/32" open end wrench (thin)
7/16" open end wrench

NOTE: See Table 4-6 on page 33 and Figure 4-1 on page 34 for additional parts information.

1. Vent any remaining nitrogen from cylinder to atmosphere. Disconnect power cord from power source.
2. Remove front panel from its enclosure as described in Section 4.2.1 on page 14, and place unit on a bench top.
3. Remove the tubing section from the VENT outlet fitting on the ORION-2D, using a 7/16" wrench
4. Remove the flexible tubing going to the transducer port. Also the flexible tubing coming from the vacuum generator, compressed air port, and the mode select assembly.

NOTE: Marking flexible tubing ends may be helpful for reinstalling ORION-2D.

5. If the transducer is wired via a connector, remove the connector by turning counter-clockwise. If the transducer is hard-wired, loosen and remove the four transducer wires (red, white, green, black) from the terminal block, TB1, on the CPU board, using the small flat-blade screwdriver.
6. Break the wire ties that hold the transducer wires so that the wires are free.
7. Using the 11/32" thin wrench, loosen and carefully remove the transducer from the ORION-2D manifold.
8. Remove the panel knobs from the COARSE (pressure), VERNIER and VENT valves using the .061" hex wrench.

NOTE: Earlier manufactured units may have the vacuum generator mounted to the ORION-2D manifold body. If so, remove the muffler, coupling and long nipple assembly from the vacuum generator.

9. While holding ORION-2D, loosen and remove the two panel screws (PN 60837) from the panel front that secure the manifold to the panel. Remove the ORION-2D.

4.2.4 ORION-2D Manifold - Valve Seat Removal

Tools required: A/R solvent (de-natured alcohol)
socket wrench
3/4" socket
needle housing socket (PN 65580)
isolation valve needle housing socket (PN 68509)
hex wrench (.050")
hex wrench (.061")
needle-nose pliers
tube fluorinated Krytox grease (PN 55593)
electric hand drill
No. 43 drill bit
No. 4-40 tap
tap handle
small hammer

NOTE: See Table 4-6 on page 33 and Figure 4-1 on page 34 for additional parts information.

1. Use a bench vise to secure the manifold by its center portion, with the valve knobs pointing upward.
2. Using the .061" hex wrench, loosen and remove the knob inserts (4) from the pressure and vent valve stems.
3. Loosen the 3/4" locknuts (1) on the COARSE (pressure) and VENT valve threaded needle housings (10).
4. Using the needle housing socket (65580) and socket wrench, loosen and remove the needle/housing assembly (10, 11).
5. To disassemble the isolation valves (inner valve), first remove the valve needle (18) by turning the gear (6) clockwise.
6. Loosen and remove the valve housings (19) using the isolation valve housing removal socket (68509) and socket wrench.

7. Remove the valve stem seats (8) and valve needle seats (9) using the needle-nose pliers.
8. Remove the inner and outer O-rings (28, 27) and back-up rings (31, 30) from the valve stem seats and wash all parts in solvent (de-natured alcohol).
9. To remove valve seats (7) from either the COARSE (pressure), VENT, or ISOLATION valves, try blowing compressed air through the inlet and outlet fittings. Otherwise, the center holes will have to be drilled and a tap used to extract the seat (Steps 10-13).
10. Using the electric hand drill with a No. 43 bit, carefully drill out the seat hole, ensuring that the drill does not touch the hole in the manifold housing directly beneath the seat.
11. Blow out any chips from the seat area using compressed air.
12. While holding the 4-40 tap steady and perpendicular to the seat, slowly turn until the tap starts to engage the seat.
13. When the tap has engaged into the seat, use a small hammer and gently knock upward against the tap handle to extract the seat.
14. After the seat has been removed, blow any remaining chips from the seat area.

4.2.5 ORION-2D Manifold - Vernier Control Disassembly

Tools required: A/R solvent (de-natured alcohol)
 1-1/4" open end wrench
 screwdriver (flat-blade)
 socket wrench
 isolation valve needle housing socket (PN 68509)

NOTE: See Table 4-6 on page 33 and Figure 4-1 on page 34 for additional parts information.

1. With the manifold housing mounted in a vise, turn the vernier shaft (14) clockwise until the piston is bottomed.
2. Loosen and remove the end cap (13) using a 1-1/4" wrench. At certain points during removal the end cap will appear to lock up. If this occurs, rotate the shaft (14) clockwise until the end cap is free to turn.
3. Remove the O-ring (29) from the end cap.
4. Remove the self-sealing screw (36) that acts as the piston key.
5. Extract the piston (15) by partially screwing in the threaded end of the shaft (14) and pulling.
6. Remove the O-ring (32) from the piston groove.
7. To disassemble the end cap/shaft assembly, mount the end cap (13) in the vise.
8. Loosen and remove the locknut (20) using the isolation valve housing socket (PN 68509) and socket wrench.
9. Loosen and remove the end bushing (12) using the same socket. Remove the shaft (14). Remove the mylar bearing washers (41 or 42) from both sides of the shaft flange.
10. Use a small pick or screwdriver to remove the O-ring (27) from the inner groove of the end cap (13).
11. Wash all parts in solvent and blow dry with compressed air.

4.2.6 ORION-2D Manifold - Vernier Control Reassembly

Tools required: tube fluorinated Krytox grease (PN 55593)
 1-1/4" wrench
 screwdriver (flat-blade)
 socket wrench
 isolation valve needle housing socket (PN 68509)

NOTE: See Table 4-6 on page 33 and Figure 4-1 on page 34 for additional parts information.

1. Coat all new O-rings with fluorinated Krytox grease before installing.
2. Install the small O-ring (27) into the end cap (13) inner groove.
3. Add mylar washers (41) or (42) to each side of shaft (14).

NOTE: Part number and quantity will vary. Washers are used to adjust vertical play in shaft (14). Try one item (41) on each side to start.

4. Apply a small amount of fluorinated Krytox grease to the shaft threads and install the shaft (14) into the end cap.
5. Install the end bushing (12) and tighten until snug using the isolation valve needle housing socket (PN 68509) and socket wrench.
6. Feel vertical motion of shaft (14). If motion exists, remove end bushing (12) and add a thicker washer at Step 3, otherwise continue to Step 7.
7. Install the locknut (20) and tighten until snug using the isolation valve needle housing socket (PN 68509) and socket wrench.
8. Install the O-ring (32) in the piston groove and install the piston (15) into the VERNIER cavity. Ensure that the piston keyway is facing the hole into which the self-sealing screw (36) is assembled.
9. Install the self-sealing screw (36) and tighten until snug.
10. Apply a thin coat of fluorinated Krytox grease and install the O-ring (29) on the end cap/shaft assembly, install into manifold and tighten until snug.

4.2.7 ORION-2C Manifold - Valve Seat Installation

Tools required:

- needle-nose pliers
- tube fluorinated Krytox grease (PN 55593)
- No. 43 drill
- A/R solvent (de-natured alcohol)
- hex wrench (.061")
- torque wrench
- socket wrench
- 3/4" socket
- needle housing socket (PN 65580)
- isolation valve needle housing socket (PN 68509)

NOTE: See Table 4-6 on page 33 and Figure 4-1 on page 34 for additional parts information.

1. Install a new seat (7) by placing it into the seat well with the needle-nose pliers. Ensure that the seat is centered within the cavity and gently tap it with a blunt end of a drill bit to install.
2. Install the valve needle seat (9) with the smaller diameter end facing outward.
3. Install new O-rings (28, 27) inside and outside of the valve stem seat. Coat all O-rings and back-up rings (30, 31) with fluorinated Krytox grease before installation. Make sure that the rings are installed in the proper order.
4. Install the valve stem seat (8) by grasping the small diameter end with the needle-nose pliers and positioning in the valve cavity, then gently pushing with the blunt end of a drill bit.
5. For COARSE (pressure) and VENT valves (two outer valves), disassemble the valve needle (11) from its housing (10) and check for any burrs or dirt on the threads which might interfere with smooth operation.
6. Clean both the needle (11) and housing (10) in solvent, dry the parts and apply a small amount of fluorinated Krytox grease to the needle threads before reassembly.
7. Assemble the valve needle (11) into the valve needle housing (10) and turn it until it stops.
8. Reinstall the needle/housing assembly into the valve cavity until finger tight.
9. Mount the manifold body (16) in a vise. For the COARSE (pressure) and VENT valves only, torque the needle/housing assembly to 325 in-lb. using the needle housing socket (PN 65580).
10. Install the housing lock nuts (1) onto the housing (10) and tighten until snug with the 3/4" socket.
11. Install the knob insert (4) over the valve needle (11) shaft, align the set screws (23) with the indents and tighten with the .061" hex wrench.
12. For the ISOLATION valve (inner valve), install the needle housing (19) and tighten until snug using the isolation valve housing installation socket (PN 68509) and torque wrench.

NOTE: There is no specified torque, so use care when tightening so as not to break the socket nibs.

13. Install the gear (6) over the isolation valve needle (18) shaft, align the set screws (26) with the indents and tighten with the .061" hex wrench.
14. Apply a small amount of Krytox grease to the threads of the ISOLATION valve needles (18) and install into the valve by turning counter-clockwise. Rotate the gear until the needle just stops at the seat.

4.2.8 ORION-2D Manifold - Panel Installation

Tools required: 7/16" open end wrench
 Phillips screwdriver
 hex wrench (.061")
 snoop, liquid leak gas detector (PN 64781)
 11/32" open end wrench (thin)

1. If not already done, remove the panel knobs from the COARSE (pressure), VERNIER, and VENT valves using the .061" hex wrench.
2. Install the manifold with the transducer port side facing the panel bottom. Install the two mounting screws (PN 60837) from the panel front and tighten until snug.

NOTE: Some manufactured units may have the vacuum generator mounted to the ORION-2D manifold body. If so, install the muffler, coupling and long nipple assembly into the vacuum generator.

3. Install the VERNIER knob (17) onto the VERNIER valve shaft (14). Align the set screws (25) with the indentations on the vernier valve shaft and tighten until snug using the .061" hex wrench.
4. To install and adjust the COARSE (pressure) and VENT valve knobs, follow the procedure in Section 4.2.9.
5. Install the transducer into the manifold port, tighten with the 11/32" thin wrench and reconnect its wire connector.

NOTE: If transducer is hard-wired, connect the four wires to the terminal block TB1 on the CPU board per Table 4-2.

Transducer Wires	Terminal Block Wires
+ Excitation	TB1-4 (Green wire)
- Signal	TB1-6 (Red wire)
+ Signal	TB1-5 (White wire)
- Excitation	TB1-7 (Black wire)

Table 4-2. Transducer Wire to Terminal Block Wire Connections

6. Install the flexible tubing going to the transducer port. Also the flexible tubing coming from the vacuum generator, compressed air port, and the mode select assembly.
7. Install the tubing section from the VENT outlet fitting on the ORION-2D, using a 7/16" wrench.
8. Fill the cylinder to approximately 1000 PSIG and check all fittings for leaks. If there are no leaks, fill nitrogen supply cylinder to maximum pressure. See Section 2.1 on page 4 for cylinder refilling procedure.
9. Install panel/chassis assembly in its enclosure as described in Table 4.2.1 on page 14.

4.2.9 ORION-2D Manifold - Valve Adjustment Procedure

Tools required: hex wrench (.050")
 hex wrench (.061")
 snoop, leak gas detector (PN 64781)

*NOTE: See Table 4-6 on page 33 and Figure 4-1 on page 34 for parts information. * denotes reference to Figure 2-2 on page 5.*

1. Energize the unit and let it warm up, 10 to 15 minutes minimum. Rotate the SUPPLY SELECT valve to the N₂ position, the RANGE SELECT switch to the 100 PSI range, DISPLAY SELECT switch and the MODE SELECT valve to pressure position.
2. To adjust the COARSE valve, go to next step. To adjust the VENT valve, go to step 18.
3. If not already done, remove the ORION-2D COARSE valve knob (3) using the .061" hex wrench
4. Using a .050" hex wrench, loosen the set screw (34) on the locknut (2) and turn the locknut clockwise to its stop.
5. Check to see that the knob insert (4) is securely fastened to the valve shaft (11). If it is loose, tighten the

set screws (23) with the .061" hex wrench.

6. Close the COARSE valve by turning the knob insert (4) clockwise until you feel the valve needle seat on the O-ring (valve is now in the closed position).
7. Rotate gear (6) on the ISOLATION valve (inner valve), counter-clockwise until stopped, then rotate clockwise 1/2 turn (opening isolation valves).
8. Use the PRESSURE LIMIT CONTROL (*1), to increase the supply pressure to between 80% and 100% of full scale.
9. Open the VENT valve (*8) to atmosphere, zero the indicator (press ZERO switch [*12] less than 5 seconds), then close the VENT valve (*8).
10. Slowly open the COARSE valve by turning the knob insert (4) counter-clockwise until you notice the displayed pressure increase. Then turn the knob insert slightly clockwise until the pressure stops rising.
11. Mark a radial line at the 12 o'clock position on the knob insert.
12. Turn the knob insert (4) clockwise to move the mark to the 6 o'clock position.
13. Turn the locknut (2) counter-clockwise until it contacts the bottom of the stop washer. Tighten the set screw (34) on the locknut with the .050" hex wrench.
14. Re-check the unit to see if displayed pressure stops when the radial line is at the 12 o'clock position.
15. Install the COARSE valve knob (3) on the knob insert (4) and engage its gear (5) with the smaller isolation valve gear (6). Turn the knob clockwise until the isolation valve is slightly snug.

 **Caution** *Do not use excessive torque when adjusting valve. The seat can be damaged.*

16. Remove the COARSE valve knob. Align the set screws (25) with the indentations on the knob insert. Install the knob on the insert while engaging the knob gear (5) with the isolation valve gear (6).
17. Tighten the set screws (25) with the .061" hex wrench. The COARSE valve is now adjusted.
18. To adjust the VENT valve, remove the ORION-2D VENT valve knob (3) using the .061" hex wrench
19. use a .050" hex wrench, to loosen the set screw (34) on the locknut (2) and turn the locknut clockwise to its stop.
20. Check to see that the knob insert (4) is securely fastened to the valve shaft (11). If it is loose, tighten the set screws (23) with the .061" hex wrench.
21. Close the COARSE valve by turning the COARSE knob (*2) clockwise.
22. Open the VENT valve (*8) to atmosphere, zero the indicator (press ZERO switch [*12] less than 5 seconds), then close the VENT valve knob insert (4) clockwise until slightly snug.
23. Use the PRESSURE LIMIT CONTROL (*1), to increase the supply pressure to between 80% and 100% of full scale.
24. Open the COARSE valve until the indicated pressure stabilizes and then close the COARSE valve.
25. Slowly turn the VENT valve knob insert (4) counter-clockwise until the display starts to decrease, then turn the knob insert (4) slightly until the indicated pressure stops decreasing.
26. Mark a radial line at the 12 o'clock position on the knob insert.
27. Turn the knob insert (4) clockwise to move the mark to the 6 o'clock position.
28. Turn the locknut (2) counter-clockwise until it contacts the bottom of the stop washer. Tighten the set screw (34) on the locknut with the .050" hex wrench.
29. Re-check the unit to see if displayed pressure stops when the radial line is at the 12 o'clock position.
30. Align the set screws (25) with the indentations on the knob insert. Install the VENT valve knob (3) on the knob insert (4).

 **Caution** *Do not use excessive torque when adjusting valve. The seat can be damaged.*

31. Tighten the set screws (25) with the .061" hex wrench. The VENT valve is now adjusted.

4.2.10 Chassis Mounted Regulator (PN 55502) - Removal, Installation and Adjustment

Tools required:

- channel locks
- adjustable wrench
- flat blade screwdriver (small)
- 7/16" open end wrench
- 9/16 " open end wrench
- hex wrench (1/4")
- A/R 1/4" wide Teflon tape, (PN 60575)
- A/R 1/2" wide Teflon tape, (PN 60911)
- snoop, liquid leak gas detector (PN 64781)
- 1/2" socket
- socket wrench
- plug fitting (PN 69199)

Removal:

1. Vent any remaining nitrogen from cylinder to atmosphere. Disconnect power cord from power source.
2. Remove front panel from its enclosure as described in Section 4.2.1 on page 14, and carefully place on a bench top.
3. Note the orientation and remove the tubing sections that connect to the regulator inlet and outlet fittings.
4. Loosen and remove the locknut using channel locks while holding the assembly from bottom of chassis.
5. Remove the regulator by sliding out from the panel rear.
6. Remove rupture disk identification label and mount the regulator in a bench vise by the flats in the base.
7. Note the orientation of the inlet and outlet fittings in the regulator. Remove the fittings and any remnants of Teflon tape from the pipe threads.

Installation:

NOTE: After installation regulator must be adjusted for an output pressure of 150-155 PSI.

1. If applicable, remove top cap, loosen locknut on shaft with 1/2" socket. Remove shaft locknut, and knob. Discard top cap and knob. Replace shaft locknut finger tight.
2. Wrap two layers of Teflon tape on the pipe threads of each fitting and install into the inlet and outlet of the regulator and ensure that each is oriented properly (same as old regulator assembly). Use a bench vise when doing this.
3. Replace rupture disk identification label on bottom of regulator and use wire to hold in place.
4. Remove large locknut from body and insert the new regulator into the chassis through bottom of mounting hole.
5. Orient assembly such that Burst Disk is perpendicular to fill port side of panel. Verify MODE SELECT assembly does not interfere.
6. Tighten the locknut using channel locks while holding the assembly from bottom of chassis.
7. Install the tubing sections to the inlet and outlet fittings.
8. Fill the cylinder to approximately 1000 PSIG and check all fittings for leaks. If there are no leaks, vent unit and continue to adjustment procedure.

Adjustment:

NOTE: Customer must supply: Standard which has, test port and display capable of reading the test port pressure. A regulated N₂ pressure source of 250 PSI with an on-off valve. 5/32" O.D. Nylon tube with a .025 wall rated at a minimum working pressure of 275 PSI. Fittings to go from the nylon tubing to the test port on the customer's standard.

1. Verify COARSE valve and PRESSURE LIMIT MONITOR are closed. To close PRESSURE LIMIT MONITOR pull regulator knob outward and turn counter-clockwise. When closed, push knob inward. VENT valve should be left open.
2. Rotate SUPPLY SELECT to N₂ position.
3. Turn customer supplied N₂ source valve to the off position, vent pressure line, then install line to fill port of UPC5100/UPC5110.

4. Remove end of nylon tubing that goes to the SUPPLY SELECT assembly, other end stays connected to vacuum control assembly. Install customer supplied nylon tube, with fitting on other end, into SUPPLY SELECT assembly. Install fitting end into test port of customer supplied Standard
5. Remove section of copper tubing that goes from Chassis Mounted Regulator to cylinder tee fitting. Tighten plug fitting (PN 69199) where copper tubing section was on regulator.
6. Input customer supplied N₂ source to regulated pressure of 250 PSI.
7. Turn Chassis Mounted Regulator shaft locknut counter-clockwise, to approximately 1/4" from top of shaft.
8. Use flat head screwdriver to rotate shaft, clockwise to increase, until Standard display reads 150-155 PSI.
9. Tighten shaft locknut, while holding screwdriver in position.
10. Shut off customer supplied N₂ source, and vent Standard.
11. Remove customer supplied nylon tube, with fitting on other end, from SUPPLY SELECT assembly and test port of customer supplied Standard.
12. Replace end of nylon tubing that goes to the SUPPLY SELECT assembly, other end is connected to vacuum control assembly
13. Remove plug fitting on regulator. Install section of copper tubing that goes from regulator assembly to cylinder tee fitting.
14. Fill the cylinder to approximately 1000 PSIG and check all fittings for leaks. If there are no leaks, fill nitrogen supply cylinder to maximum pressure. See Section 2.1 on page 4 for cylinder refilling procedure.
15. Install panel/chassis assembly in its enclosure as described in Section 4.2.1 on page 14.

4.2.11 Pressure Limit Control (PN 58409) - Regulator Removal and Installation

Tools required: 7/16" open end wrench
 hex wrench (.186")
 channel locks
 A/R 1/4" wide Teflon tape, (PN's 60575)
 snoop, liquid leak gas detector (PN 64781)

Removal:

1. Vent any remaining nitrogen from cylinder to atmosphere. Disconnect power cord from power source.
2. Remove front panel from its enclosure as described in Section 4.2.1 on page 14, and carefully place on a bench top.
3. Note the orientation and remove the tubing sections that connect to the regulator inlet and outlet fittings.
4. Loosen and remove regulator mounting nut from the front of panel, by using channel locks.
5. Note the orientation, then remove the regulator by sliding out from the panel rear.
6. Note the orientation of the inlet and outlet fittings in the regulator. Remove the fittings and any remnants of Teflon tape from the pipe threads.

Installation:

1. Wrap two layers of Teflon tape on the pipe threads of each fitting and install into the inlet and outlet of the regulator and ensure that each is oriented properly.
2. Insert the new regulator into the panel through rear of panel and rotate to proper position. Thread and tighten the mounting nut onto the regulator body from the panel front.
3. Install the tubing sections to the inlet and outlet fittings.
4. Close PRESSURE LIMIT MONITOR by pulling regulator knob outward and turning counter-clockwise. When closed, push knob inward.
5. Fill the cylinder to approximately 1000 PSIG and check all fittings for leaks. If there are no leaks, fill nitrogen supply cylinder to maximum pressure. See Section 2.1 on page 4 for cylinder refilling procedure.
6. Install panel/chassis assembly in its enclosure as described in Section 4.2.1 on page 14.

4.2.12 Supply Pressure (PN 59730) and Pressure Limit Monitor (PN 59706) Gauges - Removal and Installation

Tools required: 7/16" wrench
9/16" wrench
A/R 1/4" wide Teflon tape (PN 60575)
snoop, liquid leak gas detector (PN 64781)

Removal:

1. Vent any remaining nitrogen from cylinder to atmosphere. Disconnect power cord from power source.
2. Remove front panel from its enclosure as described in Section 4.2.1 on page 14, and carefully place on a bench top.
3. Disconnect the tubing section that connects to the gauge fitting.
4. Loosen the two thumb-nuts that hold the gauge mounting U-clamp.
5. While gripping the square portion of the gauge port with the 9/16" wrench, remove the female tube connector from the gauge, PN 59721, for Supply Pressure or PN 57684 for Pressure Limit Monitor.
6. Remove the two thumb-nuts, the mounting U-clamp, and the gauge.

Installation:

1. Before installing a new gauge, wrap two layers of new Teflon tape on the port.
2. Install gauge into panel, secure with U-clamp and tighten the two thumb screws.
3. While gripping the square portion of the gauge port with the 9/16" wrench, tighten the female tube connector on to the gauge.
4. Attach the tubing section that connects to the gauge fitting.
5. Fill the cylinder to approximately 1000 PSIG and check all fittings for leaks. If there are no leaks fill nitrogen supply cylinder to maximum pressure. See Section 2.1 on page 4 for cylinder refilling procedure.
6. Install panel/chassis assembly in its enclosure as described in Section 4.2.1 on page 14.

4.2.13 Test Port Quick-Connect Fitting (PN 59762) - Removal and Installation

If there is leakage out of the port, replace the test port quick-connect fitting.

Tools required: 5/8" two open end wrenches
7/16" open end wrench
A/R 1/4" wide Teflon tape (PN 60575)
A/R 1/2" wide Teflon tape (PN 60911)
snoop, liquid leak gas detector (PN 64781)

Removal:

1. Vent any remaining nitrogen from cylinder to atmosphere. Disconnect power cord from power source.
2. Remove front panel from its enclosure as described in Section 4.2.1 on page 14, and carefully set on a bench top.
3. From rear of panel, remove the quick-connect tubing end nut and ferrules (note orientation) from test port quick-connect fitting. Remove filter and place aside.

NOTE: Do not remove fittings attached to tubing.

4. Grasp the hex nut at the panel face with a 5/8" wrench and using a second wrench on the lock nut on rear side of panel, turn the lock nut counter-clockwise. Slide quick-connect fitting out of panel from front.

Installation:

1. Remove the tubing end nut and ferrules (note orientation) from test port quick-connect fitting. Install the quick-connect fitting thru front of panel. Thread and tighten lock nut, from rear of panel, on quick-connect fitting.
2. Slide filter into fractional tube adapter fitting (PN 56223), attached to nylon tubing. Slide tubing end nut and ferrules, in proper order, over fractional tube adapter fitting.
3. Slide fractional tube adapter fitting into quick-connect fitting from rear of panel. Thread and tighten tubing end nut, on quick-connect fitting.

4. Fill the cylinder to approximately 1000 PSIG and check all fittings for leaks. If there are no leaks fill nitrogen supply cylinder to maximum pressure. See Section 2.1 on page 4 for cylinder refilling procedure.
5. Install panel/chassis assembly in its enclosure as described in Section 4.2.1 on page 14.

4.2.14 Test Port Filter (PN 54188) - Removal, Cleaning and Installation

The port filter is a sintered element filter that can be easily removed for inspection and cleaning.

Tools required: Phillips screwdriver
 7/16" open end wrench
 9/16" open end wrench
 A/R solvent (de-natured alcohol)
 snoop, of liquid leak gas detector (PN 64781)

Removal and Cleaning:

1. Vent any remaining nitrogen from cylinder to atmosphere. Disconnect power cord from power source.
2. Remove front panel from its enclosure as described in Section 4.2.1 on page 14, and carefully place on a bench top.
3. From rear of panel, remove the quick-connect tubing end nut and ferrules (note orientation) from test port quick-connect fitting. Remove filter.

NOTE: Do not remove fittings attached to tubing.

4. Clean the filter (PN 54188) in solvent (de-natured alcohol) and blow-dry with compressed air.

Installation:

1. Slide filter into fractional tube adapter fitting (PN 56223), attached to nylon tubing. Slide tubing end nut and ferrules in proper order over fractional tube adapter fitting.
2. Slide fractional tube adapter fitting into test port quick-connect fitting (PN 59762), from rear of panel. thread and tighten tubing end nut, on quick-connect fitting.
3. Fill the cylinder to approximately 1000 PSIG and check all fittings for leaks. If there are no leaks fill nitrogen supply cylinder to maximum pressure. See Section 2.1 on page 4 for cylinder refilling procedure.
4. Install panel/chassis assembly in its enclosure as described in Section 4.2.1 on page 14.

4.2.15 Vacuum Generator - Removal, Cleaning and Installation

The vacuum generator is a Venturi device which creates a vacuum flow by use of a regulated air flow. The generator can be removed for cleaning should any contamination be found. There are two styles that may be used, one of which has a plastic body and is mounted to the panel and connected by nylon tubing to the ORION-2D manifold. The other has an aluminum body and comprises an assembly including a muffler and a long nipple that is mounted directly to the ORION-2D manifold.

Tools required: 3/16" nutdriver
 Phillips screwdriver
 7/16" open end wrench
 9/16" open end wrench
 A/R 1/4" wide Teflon tape (PN 60575)
 A/R 1/2" wide Teflon tape (PN 60911)
 A/R solvent (de-natured alcohol)
 snoop, liquid leak gas detector (PN 64781)

Removal and Cleaning - Plastic Body (PN 57026)

1. Vent any remaining nitrogen from cylinder to atmosphere. Disconnect power cord from power source.
2. Remove front panel from its enclosure as described in Section 4.2.1 on page 14, and carefully place on a bench top.
3. Remove nylon tubing from the compressed air port (top/input) and the vacuum port (front/output) of the vacuum generator.
4. Using nutdriver remove nylon spacers, (PN 60472), and remove vacuum generator.

NOTE: Some vacuum generators are mounted with screws and nuts or adhesive.

5. Clean the vacuum generator by using compressed air.

 **Warning** Do not use solvent for cleaning.

Removal and Cleaning - Aluminum Body (PN 54965)

1. Remove ORION-2D manifold from front panel as described in Section 4.2.3 on page 16, and carefully place on a bench top.

NOTE: Remove the muffler and long nipple from the vacuum generator's exhaust port prior to removing the two manifold mounting screws.

2. Mount the ORION-2D manifold in a vise. Rotate the vacuum generator counter-clockwise 90⁰ on the elbow fitting that connects it to the ORION-2D manifold body
3. Unscrew the generator from the 90⁰ elbow fitting using 7/16" wrench. Remove any remnants of Teflon tape from the threads.
4. Clean vacuum generator in solvent. Blow dry all passages with compressed air.

Installation - Plastic Body (PN 57026)

There are numerous fittings that come with unit. For this application install the following per manufacturer's data sheet and discard the rest. Using the 9/16" wrench install the compressed air port (top/input), male 5/32" tube adapter fitting, and the vacuum port (front/output), 5/32" tube female fitting.

1. Install vacuum generator on the two studs with the compressed air port (top/input) pointing upward. Using nutdriver, install and tighten nylon spacers (PN 60472).

NOTE: Some vacuum generators are mounted with screws and nuts or adhesive tape.

2. Replace nylon tubing in the compressed air port (top/input) and the vacuum port (front/output) of vacuum generator.
3. Fill the cylinder to approximately 1000 PSIG and check all fittings for leaks. If there are no leaks fill nitrogen supply cylinder to maximum pressure. See Section 2.1 on page 4 for cylinder refilling procedure.
4. Install panel/chassis assembly in its enclosure as described in Table 4.2.1 on page 14.

Installation - Aluminum Body (PN 54965)

1. Wrap two layers of Teflon tape on vacuum generators inlet fitting threads and install into the 90⁰ elbow located in the ORION-2D manifold body. Turn until the inlet fitting is snug and the vacuum generators largest side is parallel to the manifold's side.
2. Turn the 90⁰ elbow fitting 1/4 turn clockwise so that the vacuum generator's exhaust port points to the VENT valve.
3. Install the ORION-2D manifold onto front panel as described in Section 4.2.8 on page 19.

NOTE: Install the muffler and long nipple into the vacuum generator's exhaust port prior to installing the two manifold mounting screws.

4. Fill the cylinder to approximately 1000 PSIG and check all fittings for leaks. If there are no leaks, fill nitrogen supply cylinder to maximum pressure. See Section 2.1 on page 4 for cylinder refilling procedure.
5. Install panel/chassis assembly in its enclosure as described in Section 4.2.1 on page 14

4.2.16 Vacuum Control Regulator (PN 59765) - Removal, Installation and Adjustment

The vacuum control regulator is located furthest from front panel on the chassis. Some vacuum control regulators have a locking screw in place of pulling knob outward.

Tools required: 7/16" open end wrench
hex wrench (.186")
adjustable wrench
channel locks
Phillips screwdriver
A/R 1/4" wide Teflon tape, (PN's 60575)
snoop, liquid leak gas detector (PN 64781)

Removal:

1. Vent any remaining nitrogen from cylinder to atmosphere. Disconnect power cord from power source.
2. Remove front panel from its enclosure as described in Section 4.2.1 on page 14 and place on a bench top.
3. Note the orientation and remove the tubing sections that connect to the regulator inlet and outlet fittings.
4. Loosen and remove regulator mounting nut from the top of chassis, by using channel locks.
5. Note the orientation, then remove the regulator by sliding out from the bottom of chassis.
6. Note the orientation of the inlet and outlet fittings in the regulator. Remove the fittings and any remnants of Teflon tape from the pipe threads.

Installation:

1. Wrap two layers of Teflon tape on the pipe threads of each fitting and install into the inlet and outlet of the regulator and ensure that each is oriented properly.
2. Insert the new regulator into the chassis from bottom and rotate to proper position. Thread and tighten the mounting nut onto the regulator body from the panel front.
3. Install the tubing sections to the inlet and outlet fittings.
4. Fill the cylinder to approximately 1000 PSIG and check all fittings for leaks. If there are no leaks, fill nitrogen supply cylinder to maximum pressure. See Section 2.1 on page 4 for cylinder refilling procedure.
5. Install panel/chassis assembly in its enclosure as described in Section 4.2.1 on page 14

Vacuum Level Adjustment:

Field adjustment may be required at times if there is a large difference in barometric pressure at site.

1. Verify cylinder is filled to a minimum of 500 PSIG. See Section 2.1 on page 4 for cylinder refilling procedure.
2. Remove front panel from its enclosure as described in Section 4.2.1 on page 14, and carefully place on a bench top.
3. Verify COARSE valve and PRESSURE LIMIT MONITOR are closed. To close PRESSURE LIMIT MONITOR pull regulator knob outward and turn counter-clockwise. When closed, push knob inward. VENT valve should be left open.
4. Turn the MODE SELECT knob on the front panel to VACUUM position.
5. Turn RANGE SELECT switch to +/- 28 in. Hg.
6. Energize UPC5100/UPC5110 and allow warmup time.
7. Push the ZERO button (less than 5 seconds), then close the VENT valve.
8. Open the COARSE valve completely.
9. Pull VACUUM CONTROL regulator knob outward and turn clockwise to increase vacuum to a minimum display reading of 27.5. Display will be unstable and a popping sound may be heard. turn knob approximately 1/4 turn further clockwise to stabilize reading. When completed push knob inward to lock.
10. Fill the cylinder to approximately 1000 PSIG and check all fittings for leaks. If there are no leaks, fill nitrogen supply cylinder to maximum pressure. See Section 2.1 on page 4 for cylinder refilling procedure.

11. Install panel/chassis assembly in its enclosure as described in Section 4.2.1 on page 14

4.2.17 Inlet Check Valve, Nitrogen Fill Port (PN 60263) - Removal, Disassembly and Installation

Remove the check valve if it does not hold the pressure of the N₂ cylinder. The check valve can be disassembled for cleaning should any debris foul the seat area.

Tools required: Phillips screwdriver
7/16" open end wrench
9/16" open end wrench
A/R 1/2" Teflon tape, PN 60911
hex wrench (5/32")
tube fluorinated Krytox grease (PN 55593)
A/R solvent (de-natured alcohol)
snoop, liquid leak gas detector (PN 64781)
torque wrench

NOTE: See Figure 4-4 on page 35.

Removal:

1. Vent any remaining nitrogen from cylinder to atmosphere. Disconnect power cord from power source.
2. Remove front panel from its enclosure as described in Section 4.2.1 on page 14 and place on a bench top.
3. Loosen and remove the tubing end nuts from the fill port tube connector fitting (PN 59760) and chassis mounted regulator tee fitting (PN 59727).
4. Remove the fill port tube connector fitting (PN 59760) from the check valve.
5. Remove the check valve from the fill port fitting. Remove any remnants of Teflon tape from the pipe threads. Note direction of flow arrow.

Disassembly:

1. Remove lock screw from the inlet end (tail of flow arrow) using a 5/32" hex wrench.
2. Remove the insert, O-ring, poppet, and spring and clean in solvent. If any damage to O-ring is noticed, replace O-ring (PN 66654). Blow-dry parts before reassembly.
3. Apply a small amount of fluorinated Krytox grease on both sides of O-ring (PN 66654)
4. Reassemble the check valve per as shown in Figure 4-4 on page 35.
5. Torque insert lock screw to 85 in. lbs.

Installation:

1. Wrap two turns of Teflon tape on the check valve threads.
2. Install the inlet end (end opposite direction flow arrow is pointing) of check valve into the fill port fitting and tighten until snug.
3. Install the other end of the check valve into the fill port tube connector fitting.
4. Install and tighten the tubing end nuts to the fill port tube connector fitting (PN 59760) and chassis mounted regulator tee fitting (PN 59727).
5. Fill the cylinder to approximately 1000 PSIG and check all fittings for leaks. If there are no leaks fill nitrogen supply cylinder to maximum pressure. See Section 2.1 on page 4 for cylinder refilling procedure.
6. Install panel/chassis assembly in its enclosure as described in Table 4.2.1 on page 14.

4.2.18 AC Fuse (PN 58076) - Removal and Installation

1. Disconnect the power cord from the power source and line filter. Remove the fuse holder at AC INPUT.
2. Inspect fuse. If blown, replace with 1/4 Amp 250 Volt, 20mm x 5mm diameter (PN 58076).
3. Replace the fuse holder at AC INPUT.

4.2.19 AC Power/EMI Line Filter (PN 58870) - Removal and Installation

Tools required: Phillips screwdriver
1/4" open end wrench or nutdriver
A/R soldering iron
A/R shrink sleeving (PN 60735)
A/R heat gun

1. Disconnect the power cord from the power source and line filter. Remove front panel from its enclosure as described in Table 4.2.1 on page 14, and carefully set on a bench top.
2. Remove the three cable connectors from the line filter terminals.

NOTE: Some units may not have connectors and will have to have wire leads unsoldered.

3. Loosen and remove the line filter retaining nuts on the rear of panel.

NOTE: Some units may have screws on the front panel.

4. Remove the AC line filter through the panel front.
5. To install a new line filter, reverse the order of steps 1 through 4. Connect (or solder) wires to the new line filter as follows:
 - Green wire to terminal (E) Ground
 - White wire to terminal (N) Neutral
 - Black wire to terminal (P) Line

4.2.20 Power Switch (PN 55187) for Battery Units - Removal and Installation

Tools required: Phillips screwdriver
1/4" open end wrench or nutdriver
A/R soldering iron
A/R shrink sleeving (PN 60735)
A/R heat gun

Removal:

1. Disconnect the power cord from the power source and line filter. Remove front panel from its enclosure as described in Table 4.2.1 on page 14 and carefully set on a bench top.
2. Loosen and remove the nut on the panel front and remove the switch from the panel rear.
3. Remove cable clamp and unplug the switch wire harness connector from location J7 on the CPU board.
4. Unsolder and remove the nine wires from the switch terminals.

Installation:

1. Use shrink sleeving over wires/terminals for protection. Connect and solder the harness wires to the new switch terminals per the following:

Rear of Switch:	1	4	7	BATTERY TEST (Momentary)
	2	5	8	OFF
	3	6	9	OPERATE

Green/white wire to switch terminal 1	Blue/White wire to switch terminal 2
Orange wire to switch terminal 3	Yellow wire to switch terminal 4
Yellow jumper wire between switch terminals 4 & 6	Brown wire to switch terminal 5
Violet wire to switch terminal 8	Black wire to switch terminal 9

2. Install the new switch through the rear of panel. Rotate switch so that the momentary position is toward BATTERY TEST and secure it from the front of panel with the mounting nut (discard orientation washer).
3. Plug in the harness connector to its receptacle J7 on the CPU board and install cable clamp.
4. Install panel/chassis assembly in its enclosure as described in Section 4.2.1 on page 14.

4.2.21 Power Switch (PN 58878) for Non-Battery Units - Removal and Installation

Tools required: Phillips screwdriver
11/16" open end wrench
A/R soldering iron
A/R shrink sleeving (PN 64567)
A/R heat gun

Removal:

1. Disconnect the power cord from the power source and line filter. Remove front panel from its enclosure as described in Section 4.2.1 on page 14, and carefully set on a bench top.
2. Loosen the switch mounting nut and lock washer from the rear of panel.
3. Loosen and remove the trim ring from the panel front.
4. Remove switch, lock washer and nut from rear of panel as one item.
5. Unsolder and remove the wires from the switch terminals.

Installation:

1. Slide shrink sleeving over wires, connect and solder the wires onto their respective switch terminals.

Color	Terminal
Black	Normally open
Black	(C) common

Table 4-3. Power Wire Colors/Switch Terminals

2. Pull shrink sleeving over switch and connections. Apply heat. Install the new switch, lock washer and nut through the panel rear as one item. Hand tighten the trim ring from front of panel.
3. Tighten the switch mounting nut and lock washer from the rear of panel.

 **Caution** If wrench is used, do not over-tighten or damage may occur to switch.

4. Install panel/chassis assembly in its enclosure as described in Section 4.2.1 on page 14.

4.2.22 Range Select (PN 54186) and Display Select Switches (PN 59429) - Removal and Installation

Tools required: Phillips screwdriver
9/16" open end wrench or nutdriver
A/R soldering iron
hex wrench (.061")

NOTE: See Figure 4-2 on page 35 and Figure 4-3 on page 35.

Removal:

1. Disconnect the power cord from the power source and line filter. Remove front panel from its enclosure as described in Section 4.2.1 on page 14, and carefully set on a bench top.
2. Remove the switch knob using a .061" hex wrench.
3. Loosen and remove the mounting nut from the panel front.
4. Unsolder and remove the wires from the switch terminals.

Installation:

1. Connect and solder the wires onto their respective switch terminals (Table 4-4).

Range Select:		Display Select:	
Pole - Terminal	Color	Pole - Terminal	Color
1 - 3	Yellow	2 - 2	Red
1 - 6 (common)	Red	2 - 3	Blue
2 - 3	Orange	2 - 6 (common)	Green
3 - 4	Brown		

Table 4-4. Range Select and Display Select Wire Colors/Switch Terminals

2. Install the switch through the panel rear, align with front panel markings, and secure with mounting nut.
3. Install the switch knob using a .061" hex wrench.
4. Replace CPU if necessary.
5. Install panel/chassis assembly in its enclosure as described in Section 4.2.1 on page 14.

4.2.23 Zero Switch (PN 58886) - Removal and Installation

Tools required: Phillips screwdriver
 11/16" open end wrench
 A/R soldering iron

Removal:

1. Disconnect the power cord from the power source and line filter. Remove front panel from its enclosure as described in Section 4.2.1 on page 14, and carefully set on a bench top.
2. Loosen the switch mounting nut and lock washer from the rear of panel.
3. Loosen and remove the trim ring from the panel front.
4. Remove switch, lock washer and nut from rear of panel.
5. Unsolder and remove the wires from the switch terminals.

Installation:

1. Connect and solder the wires onto their respective switch terminals per Table 4-5 below:

Color	Terminal
Yellow	Normally open
Green	(C) common

Table 4-5. Wire to switch terminal connections: Zero

2. Install the new switch, lock washer and nut through the panel rear. Hand tighten the trim ring from front of panel.
3. Tighten the switch mounting nut and lock washer from the rear of panel.

 **Caution** If wrench is used, do not over tighten, damage may occur to switch.

4. Install panel/chassis assembly in its enclosure as described in Section 4.2.1 on page 14.

4.2.24 Power Supply Assembly (Battery Units Only) - Removal and Installation

120 VAC input (PN 58727); 220 VAC input (PN 58733).

Tools required: Phillips screwdriver
Flat blade screwdriver (small)
11/32" open end wrench or nutdriver

Removal:

1. Disconnect the power cord from the power source and line filter. Remove front panel from its enclosure, as described in Section 4.2.1 on page 14, and carefully set on a bench top.
2. Disconnect the three wire connectors (black, white, green) that are between the AC filter cable (PN 55540) and the cable attached to the power supply board assembly.
3. Unplug the multi-pin connector of the CPU (J6) to power supply (J1) cable (PN 55023) from the power supply board.
4. Remove the two battery cable wires (PN 56367) from the terminal block (TB1) on the power supply board.
5. Loosen and remove the four nuts that hold the power supply board and remove the board.

Installation:

1. Position the new board over the four standoffs and install four nuts. Tighten the nuts until snug.
2. Install the two battery cable wire ends into the terminal block (TB1) on the power supply board, red wire (+) to TB1-3 and black wire (-) to TB1-1.
3. Plug the CPU (J6) to power supply cable (PN 55023) connector into the power supply board (J1).
4. Connect the three connectors (black, white, green) of the AC filter cable (PN 55540) and the cable from power supply board assembly. Connect like wire colors together.
5. Install panel/chassis assembly in its enclosure as described in Section 4.2.1 on page 14.

4.2.25 BATTERY (Replacement Kit PN 55354) - Removal, Installation and Adjustments

Tools required: Phillips screwdriver
Flat blade screwdriver (small)
11/32" open end wrench or nutdriver
DC voltmeter
11.5 VDC Power Source

Removal:

1. Disconnect the power cord from the power source and line filter. Remove front panel from its enclosure as described in Section 4.2.1 on page 14, and carefully set on a bench top.
2. Disconnect the two battery cable wires (PN 56367) from the battery terminals, red wire from (+) and black wire from (-).
3. Remove the two nuts and two screws that secure the battery bracket (PN 58386).
4. Remove the bracket and battery.

Installation:

1. To install a new battery, reverse steps 2 through 4 of above.
2. Install panel/chassis assembly in its enclosure as described in Section 4.2.1 on page 14.

Adjustment - Charging Circuit:

1. Disconnect the power cord from the power source and line filter. Remove front panel from its enclosure as described in Section 4.2.1 on page 14, and carefully set on a bench top.
2. Disconnect the two battery cable wires (PN 56367) from the battery terminals, red wire from (+) and black wire from (-).
3. Connect the leads of a DC voltmeter to the battery wires.
4. With the unit's power cord connected to a power source, but the power switch on the front panel OFF, adjust the potentiometer R3 on the power supply board until the voltmeter reads 14.0 volts.

5. Unplug the power cord from the power source.
6. Disconnect the voltmeter and reconnect the battery leads to the battery terminals; red wire to (+) and black wire to (-).
7. Install panel/chassis assembly in its enclosure as described in Section 4.2.1 on page 14.

Adjustment - Battery Voltage Display Reading

NOTE: The BATTERY TEST should only be performed with the UPC5100/UPC5110 operating at Zero pressure (VENT valve open) and at the conclusion of the test, the unit's ZERO button will have to be re-pushed to re-zero the instrument.

1. Disconnect the power cord from the power source and line filter. Remove front panel from its enclosure as described in Section 4.2.1 on page 14, and carefully set on a bench top.
2. Disconnect the two battery cable wires (PN 56367) from the battery terminals, red wire from (+) and black wire from (-).
3. Connect the leads of a DC voltmeter to the battery wires.
4. Take a reading from the voltmeter.
5. Reconnect the two battery cable wires (PN 56367) to the battery terminals; red wire to (+) and black wire to (-).
6. Push the BATTERY TEST switch on the front panel. If the reading is the same as the voltmeter, go to step 8. If the reading is different, go to next step.
7. While holding toggle switch in the BATTERY TEST mode, adjust potentiometer R12 located on power supply board to be the same as previous voltmeter reading.
8. Install panel/chassis assembly in its enclosure as described in Section 4.2.1 on page 14.

Adjustment - Low Battery Display Annunciation

1. Disconnect the power cord from the power source and line filter. Remove front panel from its enclosure as described in Section 4.2.1 on page 14, and carefully set on a bench top.
2. Disconnect the two battery cable wires (PN 56367) from the battery terminals; red wire from (+) and black wire from (-).
3. Connect the leads of a 11.5 VDC power source to the battery cable wires that are connected to TB1 on the power supply board. Adjust potentiometer R9 located on power supply board to illuminate low battery indicator. For LED display type units a red LED in the left center of the display will turn on. For LCD display type units, 5 LED segments in the left of display window will illuminate in the shape of a "U."
4. Install panel/chassis assembly in its enclosure as described in Section 4.2.1 on page 14.

4.3 Orion-2D Valve Assembly Component Parts List

Ref #r	PN	Description	Quantity
1	57482	Nut, Valve Needle Housing 9/16-18	2
2	54401	Locknut	2
3	58079	Knob	2
4	57889	Knob, Insert	2
5	57256	Gear, Spur 40 Teeth	2
6	59233	Gear, Spur 18-tooth	2
7	55896	Valve Seat	4
8	59387	Valve Seat, Stem	4
9	59045	Valve, Needle Seat	4
10	54540	Housing, Valve Needle	2
11	59551	Valve Needle	2
12	57906	Bushing, End	1
13	59378	Cap, End	1
14	59495	Shaft	1
15	59241	Piston	1
16	56874	Body, Dual Valve	1
17	57580	Knob	1
18	55533	Valve Needle	2
19	55159	Housing, Valve Needle	2
20	56784	Locknut, 9/16-18UNF-3A, SST	1
21	59845	Plug, Expansion	14
23	59383	Setscrew, 6-32NCx1/8 SST	4
24	58342	Screw,Cap Hex Socket Head, #2-56UNC-3A	6
25	59322	Setscrew, 6-32NCx1/4 SST	6
26	59326	Setscrew, 2-56NC x 1/8, alloy steel	4
27	55554	O-ring, Buna N (Nitrile) 70 Durometer Color Black	5
28	55536	O-ring, Buna N (Nitrile) 70 Durometer Color Black	4
29	55573	O-ring, Buna N (Nitrile) 70 Durometer Color Black	1
30	60633	Retainer, Packing Backup	4
31	55570	Washer, Backing	4
32	55577	O-ring, Buna N (Nitrile) 70 Durometer Color Black	1
33	59245	Washer, #8 Screw Size	2
34	60202	Setscrew, hex	2
35	60837	Screw, MACH Pan Head #10- 32NFX1/2 Phillips Head 300 Series SST	2
36	58976	Screw, Self Sealing	1
38	53308	Label	1
39	59738	Fitting, Male Connector 1/8 tube x 1/8 NPT brass	1
40	41944	Connector, Male Swivel Elbow 1/8 NPT x 5/32 tube O.D.	2
41	59878	Spacer .005 thk	2
42	59880	Spacer .007 thk	2
43	57699	Fitting, Tube Male Connector 5/32 tube O.D. x 1/8 NPT	2

Table 4-6. Orion 2D Valve Assembly Parts List

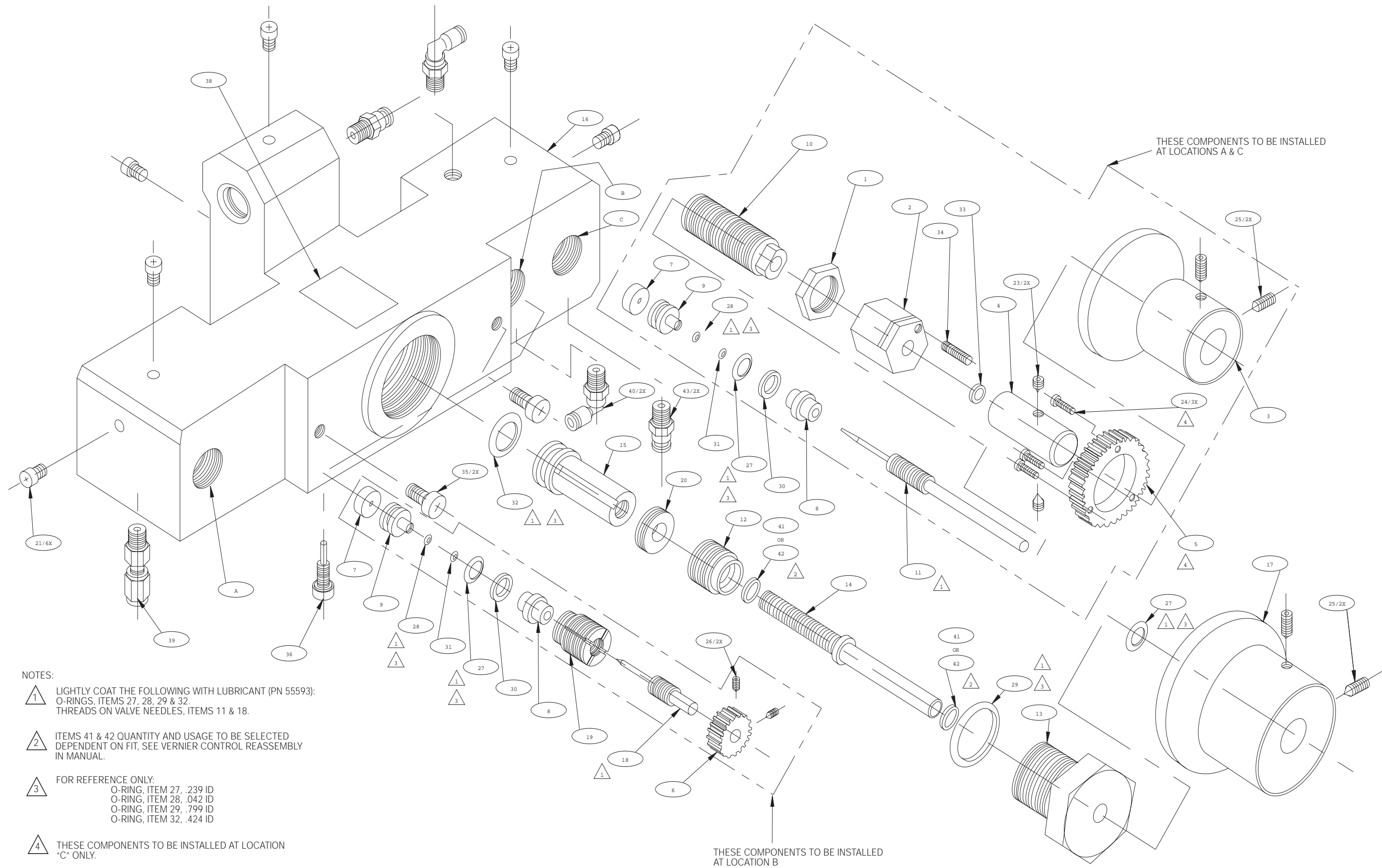

Figure 4-1. ORION-2D, Exploded View

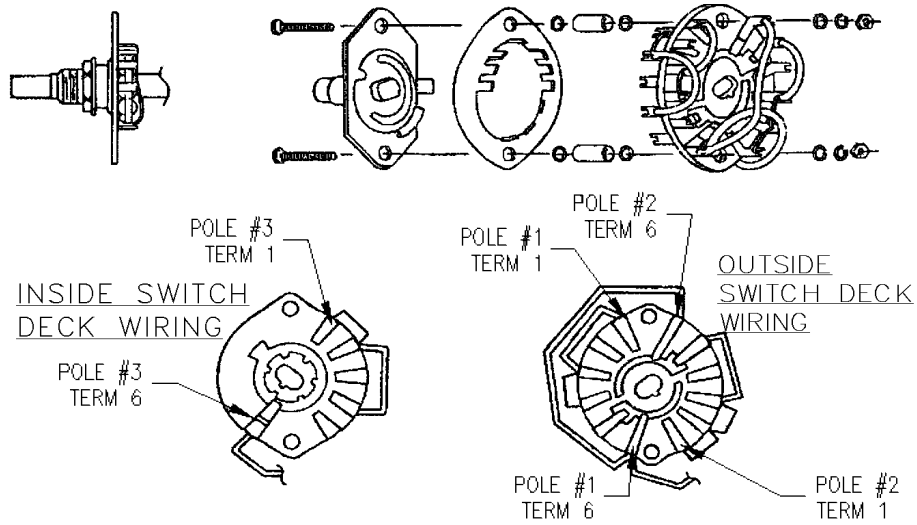

Figure 4-2. Range Select Switch Wiring

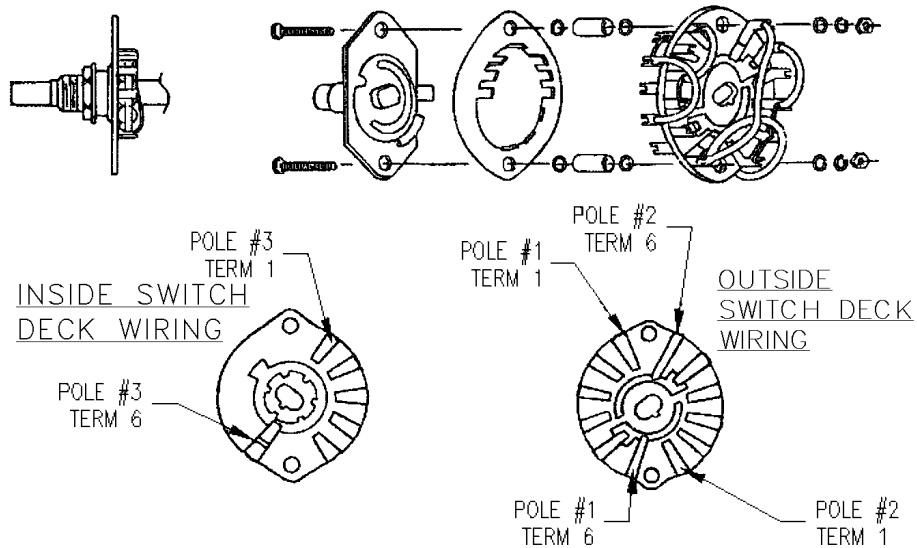

Figure 4-3. Display Select Switch Wiring

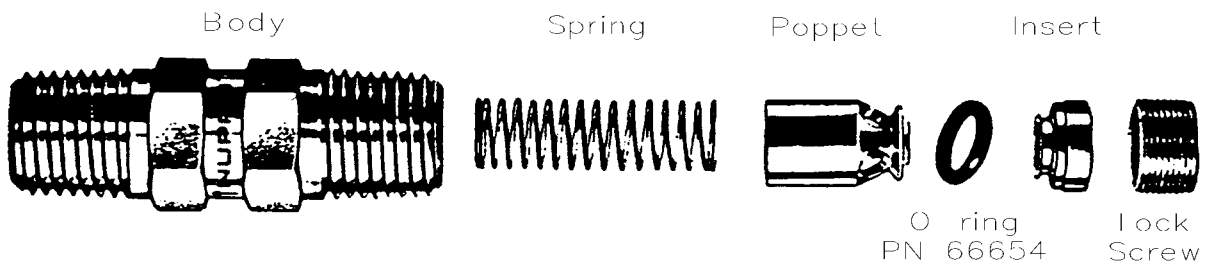

Figure 4-4. N₂ Inlet Check Valve Assembly (PN 60263)

5.0 Model Number System

	UPC 5100 -	_____	_____
	UPC 5110 -	_____	_____
		≠	≠
+-----		+	≠
≠	<u>POWER REQUIREMENTS</u>		≠
≠			≠
A -	AC Only (120 VAC)***		≠
B -	Battery Operation & 120 VAC		≠
C -	AC Only (220 VAC)***		≠
D -	Battery Operation & 220 VAC		≠
			≠
+-----			---+
≠	<u>DISPLAY</u>		
≠			
A -	Light Emitting Diode (LED)		
B -	liquid Crystal (LCD)		

*** UPC5100, Available as a Special

6.0 Available Ranges, Conversions and Resolutions

NOTE: Non-standard ranges are available by special order.

Calibrator Conversion Factors:

- kPa = PSI x 6.89476
- Bar = PSI x 0.0689476
- mBar = PSI x 68.9476
- Torr = PSI x 51.7149
- mm Hg = PSI x 51.7149
- in Hg (0°F) = PSI x 2.036
- Kg/cm² = PSI x 0.070308
- in H₂O (60°F) = PSI x 27.71
- cm H₂O = PSI x 70.308

NOTE: Display resolution 0.02% of selected range, unless it is not devisable by 1, 2, or 5.

RANGES	RESOLUTION
+ -28.000 in Hg / + -387.00 in H ₂ O / 2771.0 in H ₂ O / + -96.00 kPa / 100.00 PSI (Standard)	0.005 / 0.05 / 0.5 / 0.02 / 0.02
+ -28.000 in Hg / + -387.00 in H ₂ O / 2771.0 in H ₂ O / + -724.0 mm Hg / 100.00 PSI	0.005 / 0.05 / 0.5 / 0.1 / 0.02
+ -760.0 Torr / + -1.0000 Bar / 7.0000 Bar / + -96.00 kPa / 100.00 PSI	0.1 / 0.0002 / 0.001 / 0.02 / 0.02
+ -28.000 in Hg / + -387.00 in H ₂ O / 1034.0 mBar / + -100.00 in H ₂ O / 15.000 PSI	0.005 / 0.05 / 0.2 / 0.05 / 0.002
+ -724.0 mm Hg / + -960.0 cm H ₂ O / 7031 cm H ₂ O / + -96.00 kPa / 689.0 kPa	0.1 / 0.2 / 1 / 0.02 / 0.1
+ -28.000 in Hg / + -387.00 in H ₂ O / 775.0 mm Hg / + -96.00 kPa / 15.000 PSI	0.005 / 0.05 / 0.1 / 0.02 / 0.002
+ -28.000 in Hg / + -387.00 in H ₂ O / 5542 in H ₂ O / + -724.0 mm Hg / 200.00 PSI	0.005 / 0.05 / 1 / 0.1 / 0.02
+ -28.000 in Hg / + -387.00 in H ₂ O / 2771.0 in H ₂ O / + -14.000 PSI / 100.00 PSI	0.005 / 0.05 / 0.5 / 0.002 / 0.02
+ -28.000 in Hg / + -387.00 in H ₂ O / 5542 in H ₂ O / + -14.000 PSI / 200.00 PSI	0.005 / 0.05 / 1 / 0.002 / 0.02

Table 6-1. Display Resolutions

7.0 Options - Replacement Kits

There are numerous replacement PN's mentioned through out manual that can be ordered.

ORION-2D O-Ring Replacement Kit (Data Sheet # 65308):

- Nitrile Buna-N (standard) - PN 58499
- Ethylene-Propylene - PN 58506
- Silicone - PN 58509
- Neoprene - PN 58515
- Fluorocarbon "Viton" - PN 55277

Note: A small coating of Fluorinated Krytox grease, (PN 55593), should be applied to both sides of O-ring prior to installation.

Pressure Trap (Data Sheet # 58621) - PN 58487

Note: For UPC5100/UPC5110 model's prior to serial number A1300, approximate date prior to 7-9-1990 use Pressure Trap, PN 58492, Data Sheet # 58627.

Battery Replacement Kit - PN 55354

Test Port (output) Attachment Swivel Fitting - PN 55291

Test Port (output) Quick-Disconnect Male Hose fitting - PN 60195

Fill Port (input) Quick-Disconnect Female Hose fitting - PN 57716

Test Port (output) Hose, with Quick-Disconnect Male fitting:

- 5' Long - PN 55281
- 10' Long - PN 55328
- 15' Long - PN 55336
- 20' Long - PN 55341

Fill Port (input) Hose, with Quick-Disconnect Female fitting:

- 5' Long - PN 55282
- 10' Long - PN 55313
- 15' Long - PN 55319
- 20' Long - PN 55322

8.0 Specifications

Pressure Specifications:

Pressure ranges:	+ - 0-28 in Hg + - 0-387.00 in H ₂ O + 0-2771.0 in H ₂ O + - 0-96.00 kPa + 0-100.00 PSI
Available Pressure	
Calibrations:	Gage and Vacuum gage and absolute
Overall Accuracy:	< ±0.05% Full Scale Max. Accuracy statement includes all effects of linearity, hysteresis, repeatability and ambient temperature
Operating Temperature:	+40° to +122°F (+4.4° to +50.0° C)
Storage Temperature:	0° to +185° F (-17.8° to +85°C)
Pressure Media:	Dry gaseous nitrogen, or 150 PSI Max. shop air

Internal Pressure Cylinder:

Capacity:	7.0 ft ³ N ₂ @ 2216 PSIG
Volume:	80 in ³
Rating:	2216 PSIG
Test Pressure:	3360 PSIG
Material:	6061 Aluminum

Note: Some pressure cylinders may only be rated for a working pressure of 2015 PSIG. See information located on panel below fill port.

Pressure Supply Gage:

Size:	2-in. diameter
Range:	0–3000 PSIG
Test Pressure:	4500 PSIG

Over-pressure Rupture Disk:

Rating:	3000 PSIG, nominal
Type:	Stainless steel outer case

Pressure Media Filter:

Rating:	20 microns, Test Port
Type:	Field replaceable

Orion-2D Control Valve:

Type:	Micro-metering with replaceable soft seat
Material:	Aluminum body, clear anodized aluminum knobs, black anodized All other parts 300 series stainless steel
Relief Valve Type:	Adjustable, atmospheric bleed
Relief Valve Setting:	Adjustable to 10% above highest calibrated pressure
Relief Valve Material:	300 series stainless steel

Internal Piping:

Tubing:	1/8" O.D., 0.030" wall thickness seamless Cu 5/32" O.D., 0.025" wall thickness Nylon
Couplings:	Brass, Swagelok and Legris type

Fill Port:

Style:	Quick-disconnect.
Pressure Rating:	3000 PSIG connected, 2000 PSIG disconnected
Material:	300 series stainless steel

Test Port:

Pressure Rating:	2000 PSIG
------------------	-----------

Material:Brass

Vent Port:

Style:	1/4" 37° AN male
Pressure Rating:	2500 PSIG
Material:	Brass

Pressure Hoses:

Quantity Supplied:	Two; one input, one output
Length:	5 ft. nominal, each hose
Style:	<u>Fill (input) hose</u> - Nylon-lined core tube with synthetic braid, polyurethane cover. Fitted with quick-disconnect (Brass) socket on one end and 1/4" 37° female AN swivel pressure fitting on opposite end <u>Test Port (output) hose</u> - Nylon-lined core tube with synthetic braid, polyurethane cover. Fitted with quick-disconnect plug (Brass) on one end and 1/4" 37° female AN swivel tube coupling on the other

Pressure Limit Control Regulator (Panel Mounted):

Type:	Single stage, self-venting, bleed
Pressure Rating:	300 PSIG max. inlet

Pressure Limit Control Regulator (Chassis Mounted):

Type:	Single stage, captured vent, non-bleed
Pressure Rating:	3500 PSIG max. inlet

Vacuum Control Regulator (Chassis Mounted):

Type:	Single stage, self-venting, non-bleed
Pressure Rating:	300 PSI max. inlet

Internal Pressure Sensor:

Type:	Bonded, metal foil strain gage, sputtered thin-film or equivalent
Sensitivity:	3 mV/V nominal
Construction:	Completely weld-sealed stainless steel outer body and pressure cavity

Battery:

Type:	Rechargeable, lead-acid gel
Nominal Voltage:	12V
Approx. Weight:	2.86 lbs
Case:	Polystyrene/H.I. ABS

Carrying Case UPC5100 only:

Type: Aluminum case with latched cover and handle
Material Thickness: 0.090 in., nominal
Finish: Enamel paint, textured finish
Color: Gray

Control Panel:

Material: Aluminum (5052-H32)
Thickness: 0.125 in
Finish: Gray enamel paint with black silkscreen nomenclature

Physical Specifications:

UPC5100 Weight: 34 lbs. including all hoses and cables
UPC5110 Weight: 36 lbs.
UPC5100 Case Dim's: 10" wide x 16" long x 11.5" high
UPC5110 Case Dim's: 19" wide x 8.1" deep x 10.5" high
(Case dimensions excluding front handles)

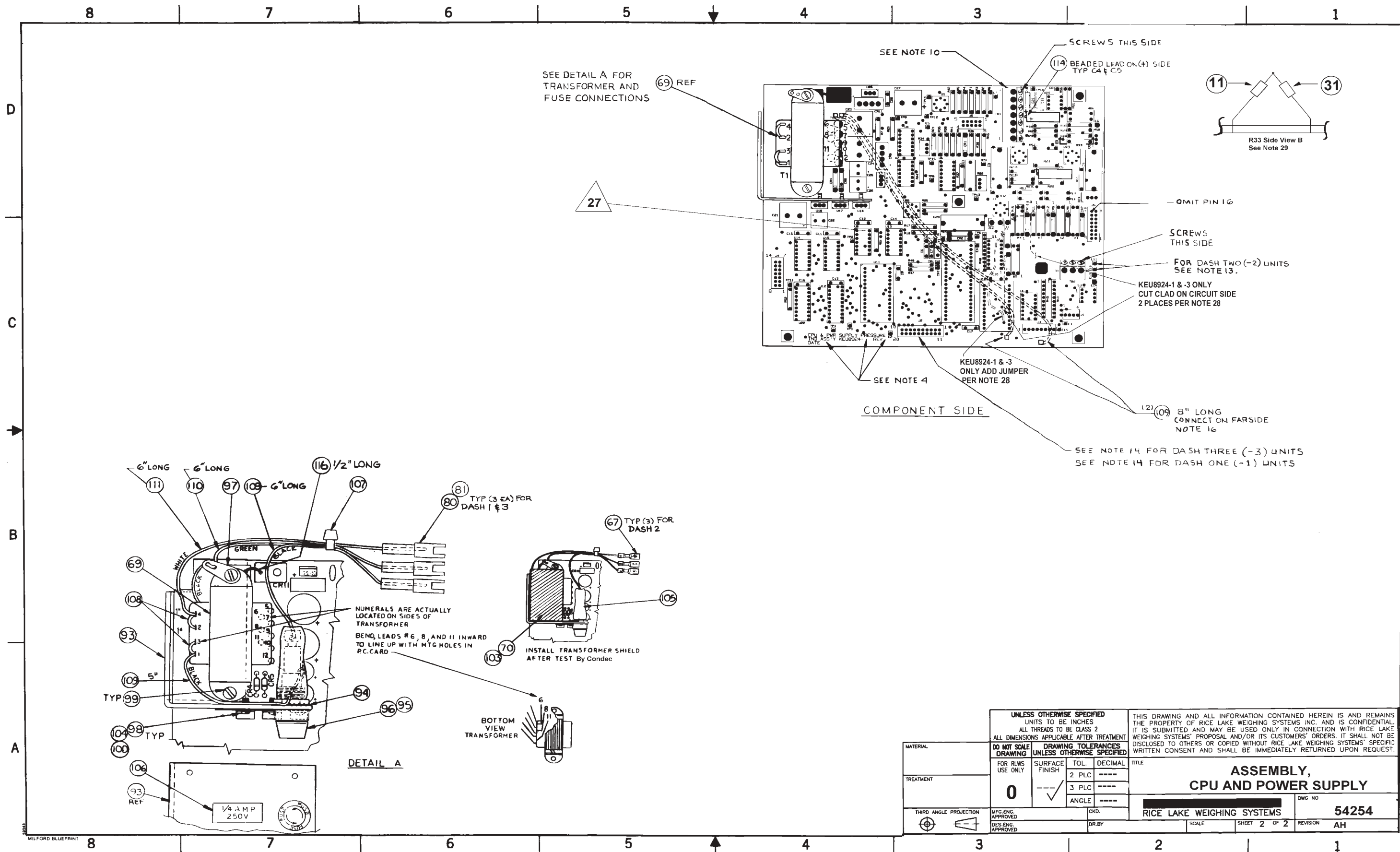
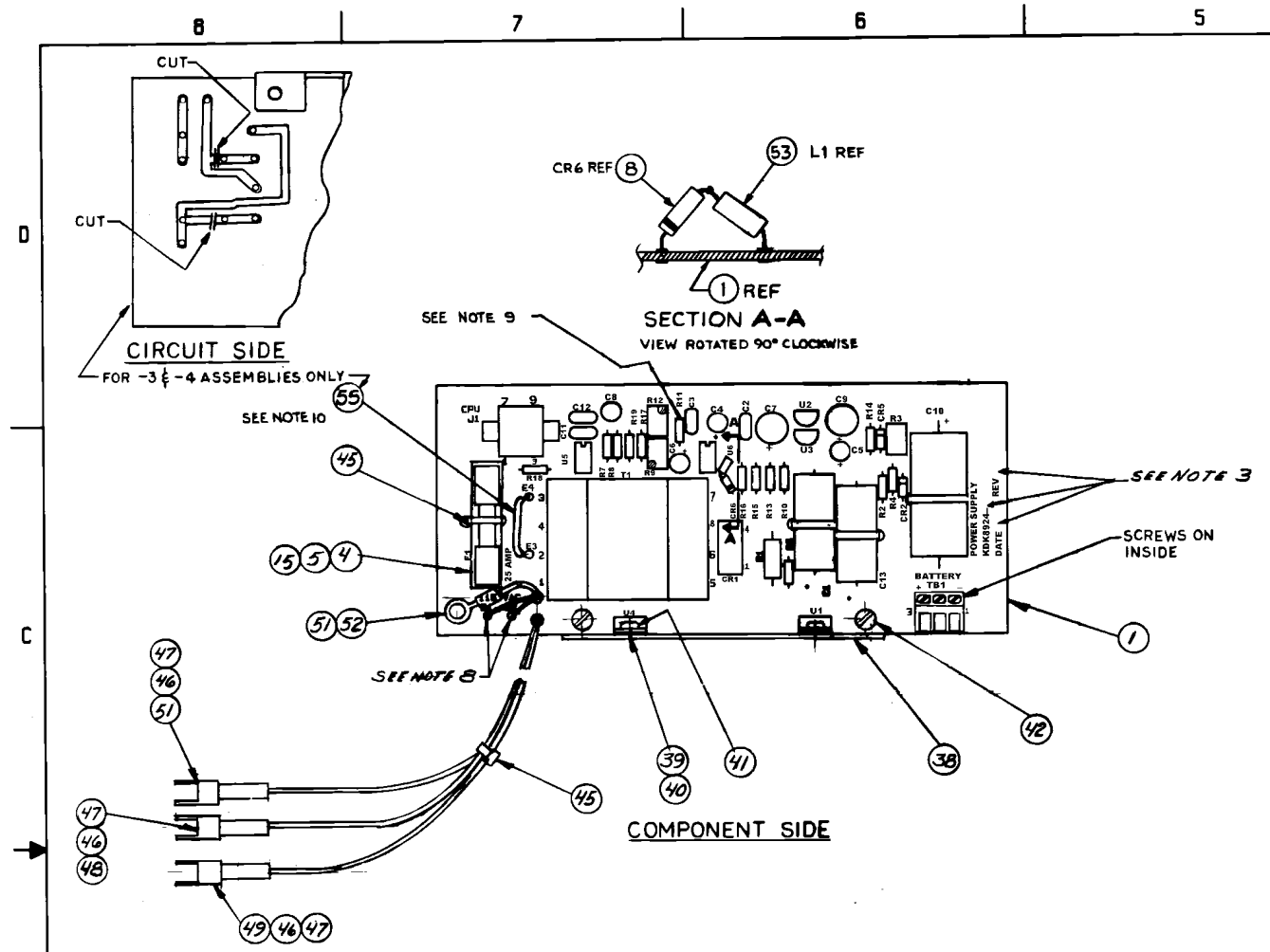

Figure 8-2. CPU & POWER SUPPLY ASSEMBLY, Sheet 2 (For Non-Battery Units Only)

ZONE	LTN	DESCRIPTIONS	DATE	APPROVED
-	-	REL. ON C/N/D1337	7/18/86	[Signature]
B	C/N/D1353	DWG SHOULD HAVE BEEN REL. ON REV B	7/18/86	[Signature]
C	C/N/D1379	ITEM 35 WAS KML1918A, 7640	7/18/86	[Signature]
D	C/N/D1465	ADDED L1 BETWEEN CR6 AND J1-6. ADDED ITEM 53 TO LIM	7/19/86	[Signature]
E	C/N/D2246	ADDED KDK8924-2	8/19/86	[Signature]
F	C/N/D2610	ADDED KDK8924-3, -4 ASSEMBLIES, NOTE 10 FOR SIDE VIEW	8/15/91	[Signature]
G	C/N/D2828	ADDED LEADER & NOTE TO TBI AT PICTORIAL	9/18/92	[Signature]
H	C/N/D2934	ADD REF TO KDK8924-2 TO NOTE 9	9/15/93	[Signature]
J	C/N/D3614	ITEM 35 WAS KML1918B	12/8/93	[Signature]



RLWS DRAWING NO. 58723
SHEET 1 OF 1
BY: KLL DATE: 12/9/99

- NOTES:
- FOR SCHEMATIC SEE BSIZE KFY7316
 - OBSERVE POLARITY OF DIODES, LED'S, DISPLAYS AND CAPACITORS.
 - STAMP APPLICABLE DASH NUMBERS, REVISION AND DATE AT FINAL ASSEMBLY USING BLACK INDELIBLE INK. CHARACTERS TO BE MIN. .12 HIGH
 - SEAT EACH COMPONENT AS FLAT TO P.C. BOARD AS DEVICE ALLOWS.
 - CAPACITORS WITH VOLTAGE RATINGS GREATER THAN THOSE SHOWN MAY BE USED IF PHYSICAL SIZE AND LEAD SPACING ARE EQUIVALENT.
 - USE ONLY FREON, SUCH AS FREON TMS FOR CLEANING.
 - TEST PROCEDURES: KAB8317
 - FEED WIRES THROUGH OPENINGS IN CARD BEFORE SOLDERING BLACK WIRE (ITEM 48) TO E1 AND WHITE WIRE (ITEM 49) TO E2 ON COMPONENT SIDE OF PCB (ITEM 1).
 - ADD JUMPER WIRE ACROSS R11 MOUNTING HOLES FOR KDK8924-2 ONLY.
 - ADD JUMPER WIRE BETWEEN E3 AND E4 ON KDK8924-3 AND KDK8924-4 ONLY, TO CONVERT 110 VAC TO 220 VAC OPERATION

QTY	FR	REV	ITEM NO.	NOMENCLATURE OR DESCRIPTION	DWG SIZE	PART OR IDENTIFYING NO.	SPECIFICATION	MATERIAL OR NOTE	REMARKS
-	-	1	56	POTENTIOMETER	C	KDU338AH	R12		50K
-	-	1	55	WIRE, JUMPER	-	M16878/4BFC0	NOTE 9		22 AWG, BLACK
-	-	1	54	RESISTOR	-	RN55C2801F	R10		2.8K ±1% 1/10W
-	-	1	53	CHOKE	C	KDP309A	L1		100 μH ±10%
-	-	1	52	TERMINAL, INSULATED	B	KAE307A			
-	-	3	51	WIRE, GRN #22AWG	-	MCF66-6			PVC INSUL
-	-	1	50	RECTIFIER, SILICON	A	KBV327A	CR2		1N4002
-	-	3	49	WIRE, WHT #22AWG	-	MCF66-10			PVC INSUL
-	-	3	48	WIRE, BLK #22AWG	-	MCF66-1			PVC INSUL
-	-	3	47	CONTACT PIN	B	KRM354A			
-	-	3	46	CONNECTOR	B	KRH354A			
-	-	5	45	STRAP, TIE DOWN	-	MS3367-4-9			FOR C1, C10, C13, R1
-	-		44						
-	-		43						
-	-	2	42	SCREW, SEMS	B	KKP83B			#6-32 x 1/4 LG
-	-	2	41	SCREW, NYLON	-	MS182122			#4-40 x 3/16 LG
-	-	1/2	40	COMPOUND, THERMAL	-	51069			
-4	-3	-1	-1	ITEM NO.					

-1=58723-
-2=58727-
-3=58729
-4=58733

QTY	FR	REV	ITEM NO.	NOMENCLATURE OR DESCRIPTION	DWG SIZE	PART OR IDENTIFYING NO.	SPECIFICATION	MATERIAL OR NOTE	REMARKS
-	-	2	39	INSULATOR, THERMAL	B	KYV297M			
-	-	1	38	HEATSINK	C	KL7365-1			
-	-	2	37	SOCKET, I.C.	B	KE251C	XU5, XU6		B PIN
1	-	-	36	RS ASSEMBLY	-	KDK8924-2			
-	-	1	35	I.C. REGULATOR	A	KML1918C	U6		1CL7662CPA
-	-	1	34	I.C. OPERATIONAL AMP	C	KBY191BV	U5		LM311P
-	-	1	33	I.C. REGULATOR	C	KGB1918B	U4		LM78M05
-	-	2	32	I.C. REGULATOR	C	KGB1918D	U2, U3		LM317LZ
-	-	1	31	I.C. REGULATOR	C	KGB1918C	U1		LM317T
-	-	1	30	RESISTOR	-	RN55C8062F	R19		80.6K ±1% 1/10W
-	-	1	29	RESISTOR	C	KFU310DN	R17		10K ±5% 1/4W
-	-	1	28	RESISTOR	-	RN55C1211F	R16		1.21K ±1% 1/10W
-	-	1	27	RESISTOR	-	RN55C8251F	R15		8.25K ±1% 1/10W
-	-	1	26	RESISTOR	-	RN55C1691F	R14		1.69K ±1% 1/10W
-	-	1	25	RESISTOR	-	RN55C1002F	R13		10K ±1% 1/10W
-	-	1	24	POTENTIOMETER	B	KBY335B	R9 (R12 ONLY)		20K
-	-	2	23	RESISTOR	-	RN55C1003F	R8, R18 (R11 ONLY)		100K ±1% 1/10W
-	-	1	22	RESISTOR	-	RN55C2002F	R10		20K ±1% 1/10W
-	-	1	21	RESISTOR	-	RN55C2492F	R7		24.9K ±1% 1/10W
-	-	1	20	RESISTOR	C	KFU310AL	R6		200Ω ±5% 1/4W
-	-	1	19	RESISTOR	-	RN55C2211F	R4		2.21K ±1% 1/10W
-	-	1	18	POTENTIOMETER	B	KBY338F	R3		500Ω ±10% .5W
-	-	1	17	RESISTOR	-	RN55C2430F	R2		243Ω ±1% 1/10W
-	-	1	16	RESISTOR	-	RWT9U4H0F	R1		14Ω ±2% 3W
-	-	1	15	FUSE COVER	B	KF7351A			PVC FLEXIBLE
-	-	1	14	CAPACITOR	B	KLN311D	C10		1000 μF 35V
-	-	2	13	CAPACITOR	B	KLY311C	C7, C9		100 μF ±20% 16V
-	-	4	12	CAPACITOR	B	KLY311G	C4, 5, 6, 8		10 μF ±20% 50V
1	-	-	11	RS ASSEMBLY	-	KDK8924-1			
-	-	4	10	CAPACITOR	A	KHV311A	C2, 3, 11, 12		.01 μF ±20% 100V
-	-	2	9	CAPACITOR	C	KLN311F	C1, C13		470 μF ±50V
-	-	2	8	DIODE	A	KFL327B	CR5, CR6		FDH300
-	-	1	7	DIODE	B	KGF327A	CR1		MDA101A
-	-	1	6	TRANSFORMER	B	KM7301B	T1		
-	-	1	5	FUSE	A	KJ350C	F1		25AMP
-	-	2	4	FUSE HOLDER	C	KD7351B	XF1		
-	-	1	3	TERMINAL BLOCK	B	KUH3300A	TB1		
-	-	1	2	CONNECTOR ASSY	B	KMB354A	J1		9 PIN
-	-	1	1	PRINTED CIRCUIT BD	C	KHL7361			

UNLESS OTHERWISE SPECIFIED DIMENSIONS ARE IN INCHES

1/8 3/16 1/4 3/8 1/2 5/8 3/4 7/8 1 1 1/8 1 1/4 1 1/2 1 3/4 2 2 1/4 2 1/2 3 3 1/4 3 1/2 4 4 1/4 4 1/2 5 5 1/4 5 1/2 6 6 1/4 6 1/2 7 7 1/4 7 1/2 8 8 1/4 8 1/2 9 9 1/4 9 1/2 10 10 1/4 10 1/2 11 11 1/4 11 1/2 12 12 1/4 12 1/2 13 13 1/4 13 1/2 14 14 1/4 14 1/2 15 15 1/4 15 1/2 16 16 1/4 16 1/2 17 17 1/4 17 1/2 18 18 1/4 18 1/2 19 19 1/4 19 1/2 20 20 1/4 20 1/2 21 21 1/4 21 1/2 22 22 1/4 22 1/2 23 23 1/4 23 1/2 24 24 1/4 24 1/2 25 25 1/4 25 1/2 26 26 1/4 26 1/2 27 27 1/4 27 1/2 28 28 1/4 28 1/2 29 29 1/4 29 1/2 30 30 1/4 30 1/2 31 31 1/4 31 1/2 32 32 1/4 32 1/2 33 33 1/4 33 1/2 34 34 1/4 34 1/2 35 35 1/4 35 1/2 36 36 1/4 36 1/2 37 37 1/4 37 1/2 38 38 1/4 38 1/2 39 39 1/4 39 1/2 40 40 1/4 40 1/2 41 41 1/4 41 1/2 42 42 1/4 42 1/2 43 43 1/4 43 1/2 44 44 1/4 44 1/2 45 45 1/4 45 1/2 46 46 1/4 46 1/2 47 47 1/4 47 1/2 48 48 1/4 48 1/2 49 49 1/4 49 1/2 50 50 1/4 50 1/2 51 51 1/4 51 1/2 52 52 1/4 52 1/2 53 53 1/4 53 1/2 54 54 1/4 54 1/2 55 55 1/4 55 1/2 56 56 1/4 56 1/2

ALL MACH. SURFACES ✓ DIMS
DRILL HOLES PER ANSI Y14.5
UNLESS OTHERWISE SPECIFIED PER Y14.5
IS: CHAMFER FIRST THREAD
TOLERANCES PER ANSI Y14.5-1973
CONV. TOL. APPLY TO STOCK SIZES

DRAMA G. Newton 6-26-86
CHECKED J. Welsh 6-30-86
DWG. 6-30-86
RELEASED 6-30-86

F.T.N CONSOLIDATED CONTROLS™
BETHEL, CT 06801

POWER SUPPLY ASSEMBLY

SIZE: 0 FSCH NO. 02750 DWG NO. KDK8924
SCALE: 1:1 WT: 1.00 SHEET 1 OF 1

Figure 8-3. POWER SUPPLY ASSEMBLY (For Battery Units Only)

REVISIONS			
REV	REFERENCE	INIT	DATE
THRU	SEE C/N'S FOR CHG DESCRIPTIONS	JEW	SEE CHG #S
AC	CIN D3121; IT. 95 QTY WAS 11 1/2 IN.	JEW	7/7/94
AD	CAUTION: ITEM 10 HAS REFERENCE TO AN UNRESOLVED STATUS (ITEM 10). IT IS BEING REWORKED.	JEW	3/17/98
AE	CIN D4001 LM. ITEM 53 PART WAS K.E3110. DESC. WAS CAPACITOR, MYLAR.	JEW	11/8/99
AF	QTY OF ITEM 10 WAS 4-6, 3-4, 12, 3-4, 4-1, 12. ADD NOTE 27 (PUSH BTN).	JEW	8/4/00
AG	DELETED ITEMS 2, 10, AND 11.	JEW	10/5/00
AH	MODIFIED NOTE 27 "CATHODE" REPLACED WITH "ANODE". REBRAIN ON PLANS FORMAT.	JEW	11/27/00
AJ	ADDED NOTES 28 AND 29.	JEW	12/28/00
AK	E001888: ADDED NOTE 30, MODIFIED INFO IN ITEM NO. 96 ON LIST OF MATL. REMOVED SPEC. FROM ITEM 65 AND 1 THRU 57.	JEW	12/12/01

- NOTES:
- FOR SCHEMATIC SEE DWG. (DIKHN7316).
 - OBSERVE POLARITY OF ICs, CAPACITORS, DIODES, AND TRANSISTORS.
 - TEST PROCEDURE: (AJ)KU7317
 - MARK APPLICABLE DASH NUMBER, REVISION LEVEL, AND DATE IN 1/8 INCH HIGH CHARACTERS. USE BLACK EPOXY INK.
 - ITEM 30 REFERENCE DESIGNATIONS: R16, R26, R41, R42, R44, R46, R47, R54, WITH R28 IN KET8924-1 & KET8924-3
 -
 - ITEM 3 REFERENCE DESIGNATIONS: U1, U2, U3, U26, WITH U23 IN KET8924-1 & KET8924-3
 - ITEM 56 REFERENCE DESIGNATIONS: C8 AND C10-C26, WITH C28 IN KET8924-1 & KET8924-3
 - ITEM 65 REFERENCE DESIGNATIONS: CR7, CR8, CR9, AND CR12, WITH CR10 IN KET8924-1 & KET8924-3
 - TB1 IS MADE UP OF ONE (1) ITEM 82 AND ONE (1) ITEM 91. TB2 IS MADE UP OF ONE (1) ITEM 82.
 - USE TWO 8" LENGTHS OF ITEM 95, #20AWG BLK INS. WIRE, TO CONNECT COMMON CLAD, AS SHOWN IN HIDDEN LINES, COMPONENT SIDE VIEW, SHEET 2.
 - REFERENCE: ASSEMBLY # USED IN KET8924-1 UPC5000 KET8924-3 UPC5100 KET8924-4 UPS3000
 - REFERENCE: ASSEMBLY # QTY ITEM # ADD BETWEEN KET8924-1 2 66 E9 & E10, E12 & E13 KET8924-2 2 66 E9 & E11, E12 & E15 KET8924-3 3 66 E3 & E16, E9 & E10, E12 & E13 KET8924-4 2 66 E9 & E11, E12 & E15
 - ON KET8924-1 & KET8924-3: DELETE J2 PINS 6 THRU 10, AND 16 THRU 20. ON KET8924-2: DELETE J2 PINS 9, 10, & 19, 20
 - ON KET8924-3 ONLY: CUT CLAD AT CUT MARKS "G" & "E" AND BETWEEN R23A MOUNTING HOLES.
 - ITEM 22 REFERENCE DESIGNATIONS: K5, WITH K4 USED IN KET8924-1 & KET8924-3 ONLY
 - ITEM 32 REFERENCE DESIGNATIONS: R30 USED IN KET8924-1 AND KET8924-3, R23 & R23B USED IN KET8924-3 ONLY.
 - ITEM 33 REFERENCE DESIGNATIONS: R55, WITH R11 USED IN KET8924-1, KET8924-2, & KET8924-4.
 - ITEM 35 REFERENCE DESIGNATIONS: R15, WITH R3 & R4 USED IN KET8924-1, KET8924-2, & KET8924-4.
 - ITEM 37 REFERENCE DESIGNATIONS: R8, R9, R10, & R18 WITH R32 IN KET8924-3 ONLY.
 - ITEM 39 REFERENCE DESIGNATIONS: R59, WITH R58 USED IN KET8924-1 & KET8924-3 ONLY.
 - ITEM 53 REFERENCE DESIGNATIONS: C3, C29, WITH C9 USED IN KET8924-1 & KET8924-3 ONLY.
 - ITEM 64 REFERENCE DESIGNATIONS: CR2, WITH CR1 USED IN KET8924-1, KET8924-2, & KET8924-4.
 - ITEM 75 REFERENCE DESIGNATIONS: J5, WITH J2 USED IN KET8924-2 ONLY.
 - ITEM 83 REFERENCE DESIGNATIONS: XU4, XU6, XU7, XU8, XU13. ITEM 84 REFERENCE DESIGNATIONS: XS1, XU5, XU14, XU15.
 - ITEM 92 REFERENCE DESIGNATIONS (28 PLACES): TP1-TP6, TP8-TP12, TP14, TP15, E1-E5, E7-E16.

- KET8924-1 AND KET8924-3: ON CIRCUIT SIDE OF BOARD, CUT CLAD BETWEEN CR12 ANODE AND VIA UNDER U10. CUT CLAD BETWEEN CR10 ANODE AND U6-4. ADD 3 1/2" 30AWG WIRE, ITEM 96, BETWEEN CR10 ANODE AND VIA UNDER U10, SEE PICTORIAL.
- CAPACITOR LEADS TO BE WRAPPED WITH NONCONDUCTIVE TUBE TO PREVENT ELECTRICAL ARCING.
- CAPACITOR TO BE LAID DOWN FLAT AGAINST BOARD, AND WRAPPED WITH NONCONDUCTIVE SHRINK TUBE TO PREVENT ELECTRICAL ARCING.
- CUT ITEM 96 TO REQUIRED LENGTHS. ON CIRCUIT SIDE OF BOARD ASSEMBLY JUMPER U8 PINS 9 AND 10 TO U8-7(GND).

- 1 = 59037
- 2 = 59040
- 3 = 59048
- 4 = 59052

1/2"	-	1/2"	-	97	WIRE, BUS, 18 AWG	-	QQW343H18SIT				
6"	4 1/2"	6"	4 1/2"	96	WIRE, WIRE WRAP, 30 AWG	-	F985				
19 1/2"	19 1/2"	19 1/2"	19 1/2"	95	WIRE, BLACK, 20 AWG	-	M22759/11-20-0			NOTE 11	
				94							
A/R	A/R	A/R	A/R	93	SEALANT	-	SA13-193			RTV162	
28	28	28	28	92	CONNECTOR PIN	B	KEK7354A			NOTE 26	
1	1	1	1	91	TERMINAL BLOCK	B	KUH3300C			TB1	4 POS, NOTE 10
1	1	1	1	90	SOCKET, IC	B	KD251B			XU11	28 PIN DIP
1	1	1	1	89	SOCKET, IC	B	KD251C			XU9	40 PIN DIP
1	1	1	1	88	SOCKET, IC	B	KD251A			XU10	24 PIN DIP
1	1	1	1	87	SOCKET, IC	B	KE251E			XU12	20 PIN DIP
1	1	1	1	86	SOCKET, IC	B	KE251D			XU22	18 PIN DIP
2	2	2	2	85	SOCKET, IC	B	KE251C			XS3, XU20	8 PIN DIP
4	4	4	4	84	SOCKET, IC	B	KE251B			NOTE 25	16 PIN DIP
5	5	5	5	83	SOCKET, IC	B	KE251A			NOTE 25	14 PIN DIP
2	2	2	2	82	TERMINAL BLOCK	B	KUH3300A			TB1 & TB2	3 POS, NOTE 10
1	1	1	1	81	CONNECTOR, CONTACT	B	KMB354C			J6	12 PIN
1	1	1	1	80	CONNECTOR	B	KMB354A			J7	9 PIN
1	1	1	1	79	CONNECTOR	C	KPC354C			J1	4 PIN
1	1	1	1	78	CONNECTOR	C	KBN7354B			J3	8 PIN
1	-	-	-	77	CONNECTOR	B	KNM354D			J2	20 PIN
1	1	1	1	76	CONNECTOR	B	KNM354B			J4	14 PIN
1	1	2	1	75	CONNECTOR	B	KNM354C			NOTE 24	16 PIN
1	1	1	1	74	CONNECTOR	B	KPC354E			J8	3 PIN
1	1	1	1	73	SWITCH, 4 POSITION DIP	B	KTF182G			S3	4 SPST
1	1	1	1	72	SWITCH, MOMENTARY	B	KAH7182A			S2	PUSH BUTTON
1	1	1	1	71	SWITCH, 8 POSITION DIP	B	KTF182F			S1	8 SPST
-	1	-	1	70	CONNECTOR	B	KNM354A			J2	10 PIN NOTE 14
1	-	1	-	69	TRANSISTOR	C	KEA165A			Q1	2N4401
1	1	1	1	68	CRYSTAL	A	KF357A			Y1	4.9152 MHZ
				67							
2	3	2	2	66	RECEPTACLE, SHORTING	B	KEF7354A			NOTE 13	
4	5	4	5	65	DIODE, SILICONE	A	KBV327A			NOTE 9	1N4002
2	1	2	2	64	DIODE	A	KFL327B			NOTE 23	FDH300
				63							
				62							
				61							
				60							
				59							
2	2	2	2	58	CAPACITOR, ELECTROLYTIC	B	KGE311Q			POLARIZED	C4,C5
-	1	-	1	57	CAPACITOR, ELECTROLYTIC	B	KAU7311J			POLARIZED	C27
-4	-3	-2	-1		NOMENCLATURE OR DESCRIPTION	DWG SIZE	PART OR IDENTIFYING NO.	SPECIFICATION	MATERIAL OR NOTE	REMARKS	
LIST OF MATERIALS (CONTINUED)											

18	19	18	19	56	CAPACITOR, CERAMIC	A	KHV311A			NOTE 8	.01uF 50V
2	2	2	2	55	CAPACITOR, MICA	-	CM05ED200J03			C6,C7	20pF 5% 500V
-	1	-	-	54	CAPACITOR, POLYCARBONATE	C	KMV311P			C1	.1uF 10% 100V
2	3	2	3	53	CAPACITOR, METAL POLY	B	KDE7311B			NOTE 22	.5uF 10% 100V
1	1	1	1	52	CAPACITOR, CERAMIC	A	KKF311B			C2	1uF 20% 50V
1	-	1	1	51	CAPACITOR, MYLAR	C	KMV311T			C1	.22uF 5% 100V
1	-	1	-	50	RESISTOR, COMPOSITION	-	RCR07G471J3			R31	470 5% 1/4W
1	-	1	1	49	RESISTOR, METAL FILM	C	KPW310Z			R32	50K 0.1% 0.1W
1	1	1	1	48	POTENTIOMETER	C	KBY338F			R34	500 10% 1/2W
-	1	-	-	47	RESISTOR, METAL FILM	-	RN55C2000F			R21	200 1% 0.1W
-	1	-	1	46	RESISTOR, COMPOSITION	-	RCR07G241J3			R20	240 5% 1/4W
-	1	-	-	45	RESISTOR, METAL FILM	C	KPW310D			R12	1.5K 0.1% 0.1W
-	1	-	1	44	RESISTOR, METAL FILM	-	RN55C3321F			R7	3.32K 1% 0.1W
3	3	3	3	43	RESISTOR, SIP	C	KMA310U			R40,R48,R49	10K 2% .3W
1	-	1	-	42	RESISTOR, COMPOSITION	-	RCR07G102J3			R27	1K 5% 1/4W
2	2	2	2	41	RESISTOR, COMPOSITION	-	RCR07G103J3			R51,R52	10K 5% 1/4W
1	1	1	1	40	RESISTOR, COMPOSITION	-	RCR07G245J3			R43	2.4M 5% 1/4W
1	2	1	2	39	POTENTIOMETER	B	KBY338B			NOTE 21	20K 10% 1/2W
2	2	2	2	38	RESISTOR, METAL FILM	C	KPW310G			R56,R57	80K 0.1% 0.1W
4	5	4	4	37	RESISTOR, METAL FILM	C	KPW310N			NOTE 20	10K 0.1% 0.1W
2	2	2	2	36	RESISTOR, METAL FILM	C	KPW310			R19,R22	SELECT
3	1	3	3	35	RESISTOR, METAL FILM	C	KPW310W			NOTE 19	20K 0.1% 0.1W
1	-	1	1	34	RESISTOR, METAL FILM	C	KPW310AY			R13	13.3K 0.1% 0.1W
2	1	2	2	33	RESISTOR, METAL FILM	C	KPW310R			NOTE 18	5K 0.1% 0.1W
-	3	-	1	32	RESISTOR, METAL FILM	C	KPW310E			NOTE 17	1.0K 0.1% 0.1W
1	1	1	1	31	RESISTOR, METAL FILM	-	RN55C6981F			R17	6.98K 1% 0.1W
8	9	8	9	30	RESISTOR, METAL FILM	-	RN55C1001F			SEE NOTE 5	1.0K 1% 0.1W
5	5	5	5	29	RESISTOR, METAL FILM	-	RN55C8062F			R35-R39	80.6K 1% 0.1W
1	-	1	1	28	RESISTOR, METAL FILM	-	RN55C4321F			R21	4.32K 1% 0.1W
3	3	3	3	27	RESISTOR, METAL FILM	-	RN55C1002F			R5,R6,R45	10K 1% 0.1W
1	1	1	1	26	RESISTOR, METAL FILM	-	RN55C1182F			R25	11.8K 1% 0.1W
2	2	2	2	25	RESISTOR, METAL FILM	C	KPW310B			R1,R2	100K 0.1% 0.1W
-	1	-	1	24	RESISTOR, METAL FILM	-	RN55C10R0F			R29	10 1% 0.1W
3	3	3	3	23	RELAY	C	KJU431B			K1,K2,K3	
1	2	1	2	22	RELAY	C	KJU431A			NOTE 16	
-	-	-	1	21	RESISTOR, METAL FILM	-	RN55C1402F			R33	14K 1% 0.1W
-	1	-	1	20	POTENTIOMETER	C	KBW338E			R24	2K 10% 1/2W
-	1	-	-	19	RESISTOR, METAL FILM	C	KPW310H			R11	1.75K 0.1% 0.1W
-	1	-	-	18	RESISTOR, METAL FILM	C	KPW310M			R23C	200 1% 0.1W
-	2	-	-	17	RESISTOR, METAL FILM	C	KPW310BA			R3,R4	15K 0.1% 0.1W
-	1	-	-	16	RESISTOR, METAL FILM	-	RN55C2491F			R33	2.49K 1% 0.1W
-	1	-	1	15	IC, VOLTAGE REGULATOR	C	KGB1918C			U25	LM317T 3 PIN
1	1	1	1	14	IC, 4 BIT BINARY COUNTER	C	KBE8918AG			U15	74HCT161 16 PIN
1	1	1	1	13	IC, NONINVERTED 3 STATE OUT.	C	KBE8918BD			U14	74HCT257 16 PIN
1	1	1	1	12	IC, OCTAL D TYPE FLIP-FLOP	C	KBE8918BL			U12	74HCT374 20 PIN
1	1	1	1	9	IC, 8 BIT MICROCOMPUTER	C	KBF8918A			U9	80C39 40 PIN
3	3	3	3	8	IC, 2 INPUT NAND	C	KBE8918A			U8,U13,U7	74HCT00 14 PIN
1	1	1	1	7	IC, OPERATIONAL AMPLIFIER	B	KDH8918A			U20	AD708NJX 8 PIN
1	1	1	1	6	IC, HEX BUFFER/DRIVER	C	KAG1918AE			U6	7417 14 PIN
1	1	1	1	5	IC, QUAD SWITCH	A	KEV1918D			U5	LF1333N 16 PIN
1	1	1	1	4	IC, QUAD AMPLIFIER	A	KER1918A			U4	HA4741 14 PIN
4	5	4	5	3	IC, OPERATIONAL AMPLIFIER	C	KBY1918U			NOTE 7	OP-07C 8 PIN
					</						

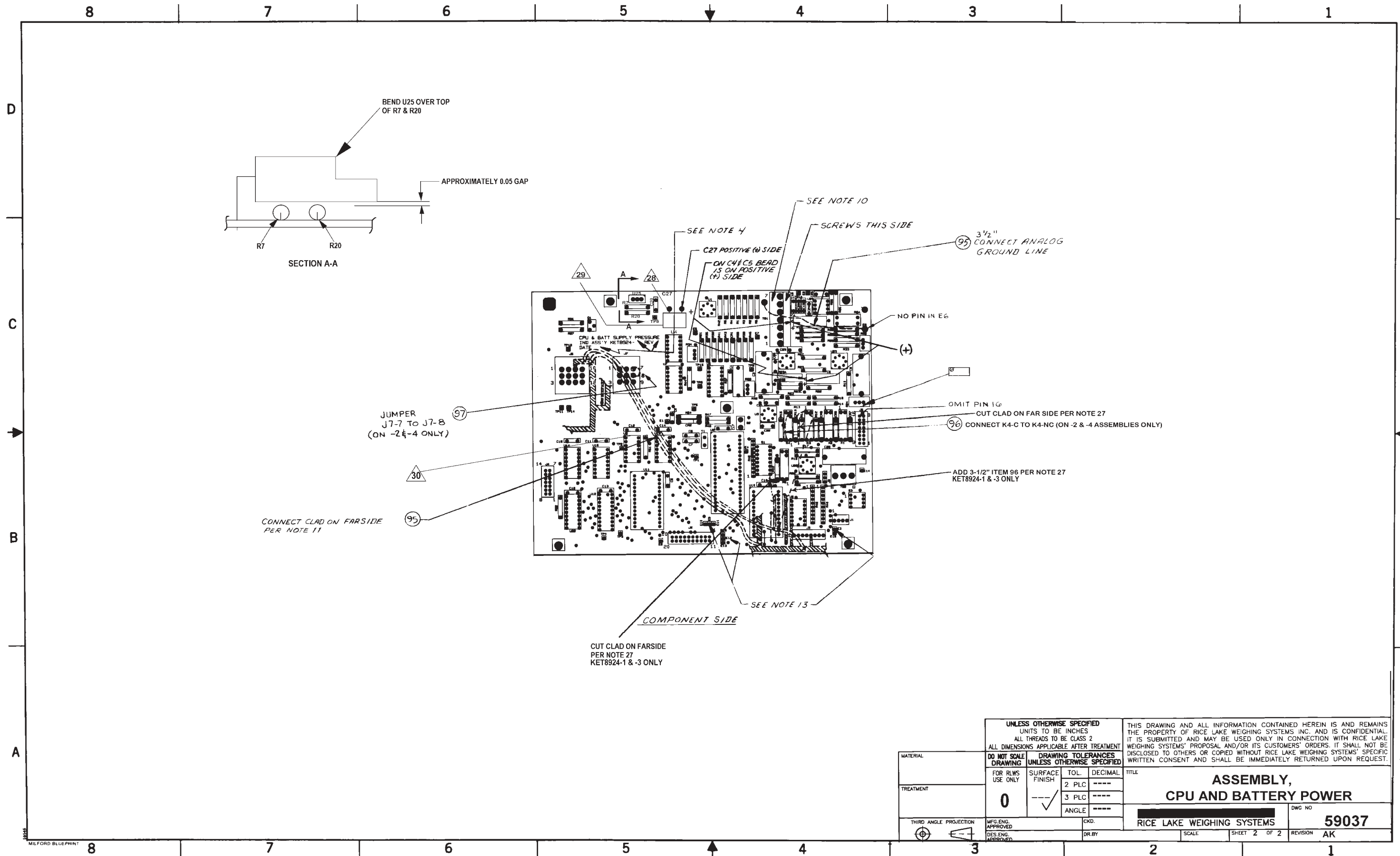

Figure 8-5. CPU Assembly, sheet 2 (For Battery Units Only)

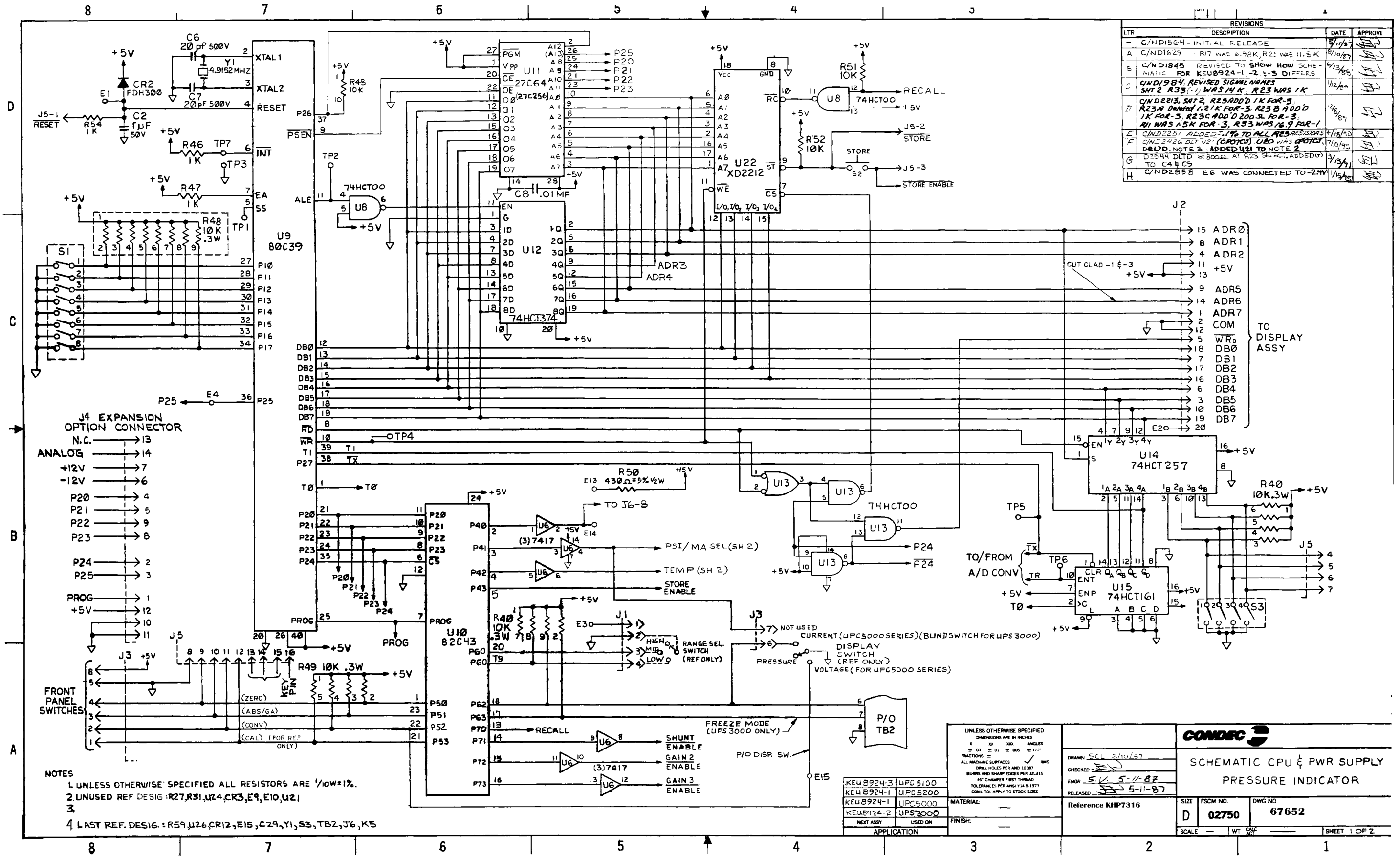

Figure 8-6. CPU & POWER SUPPLY SCHEMATIC, Sheet 1 (For Non-Battery Units Only)

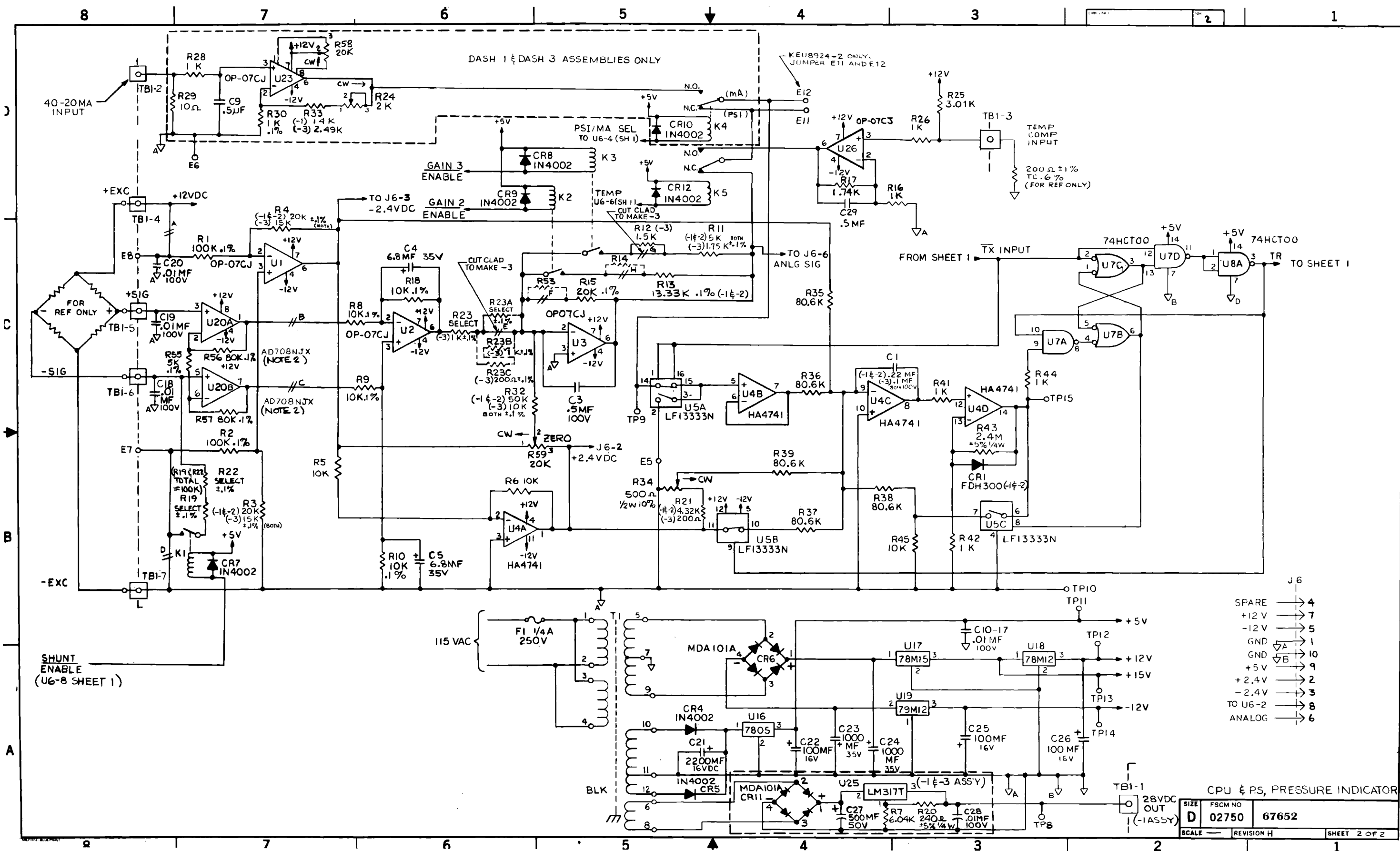
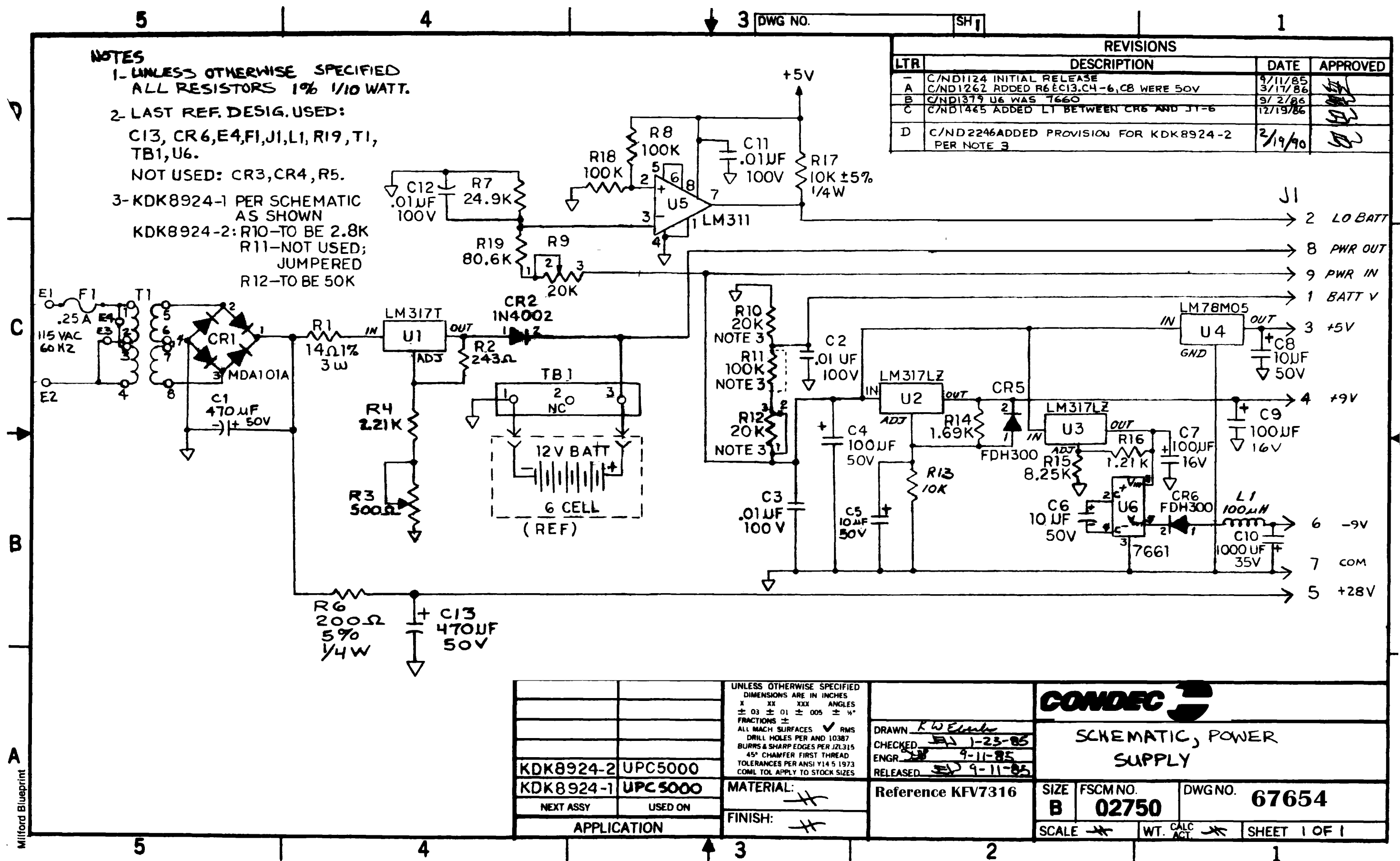

Figure 8-7. CPU & POWER SUPPLY SCHEMATIC, Sheet 2 (For Non-Battery Units Only)



NOTES
 1- UNLESS OTHERWISE SPECIFIED ALL RESISTORS 1% 1/10 WATT.
 2- LAST REF. DESIG. USED:
 C13, CR6, E4, F1, J1, L1, R19, T1, TB1, U6.
 NOT USED: CR3, CR4, R5.
 3- KDK8924-1 PER SCHEMATIC AS SHOWN
 KDK8924-2: R10-TO BE 2.8K
 R11-NOT USED; JUMPED
 R12-TO BE 50K

REVISIONS			
LTR	DESCRIPTION	DATE	APPROVED
-	C/ND1124 INITIAL RELEASE	9/11/85	
A	C/ND1262 ADDED R6 EC13.C4-6, CB WERE 50V	3/17/86	
B	C/ND1379 U6 WAS 7660	9/2/86	
C	C/ND1465 ADDED L1 BETWEEN CR6 AND J1-6	12/19/86	
D	C/ND2246 ADDED PROVISION FOR KDK8924-2 PER NOTE 3	2/19/90	

UNLESS OTHERWISE SPECIFIED DIMENSIONS ARE IN INCHES X XX XXX ANGLES ± 03 ± 01 ± 005 ± W* FRACTIONS ± ALL MACH SURFACES ✓ RMS DRILL HOLES PER AND 10387 BURRS & SHARP EDGES PER JZL315 45° CHAMFER FIRST THREAD TOLERANCES PER ANSI Y14.5 1973 COML TOL APPLY TO STOCK SIZES		CONDEC	
DRAWN <i>RW Elnick</i>		SCHEMATIC, POWER SUPPLY	
CHECKED <i>FA 1-23-85</i>		SIZE B FSCM NO. 02750 DWGNO. 67654	
ENGR. <i>EB 9-11-85</i>		Reference KVV7316	
RELEASED <i>ED 9-11-85</i>		SCALE <i>---</i> WT. CALC <i>---</i> SHEET 1 OF 1	
KDK8924-2	UPC5000	MATERIAL: <i>---</i>	
KDK8924-1	UPC5000	FINISH: <i>---</i>	
NEXT ASSY	USED ON	APPLICATION	

Figure 8-8. POWER SUPPLY SCHEMATIC, (For Battery Units Only)

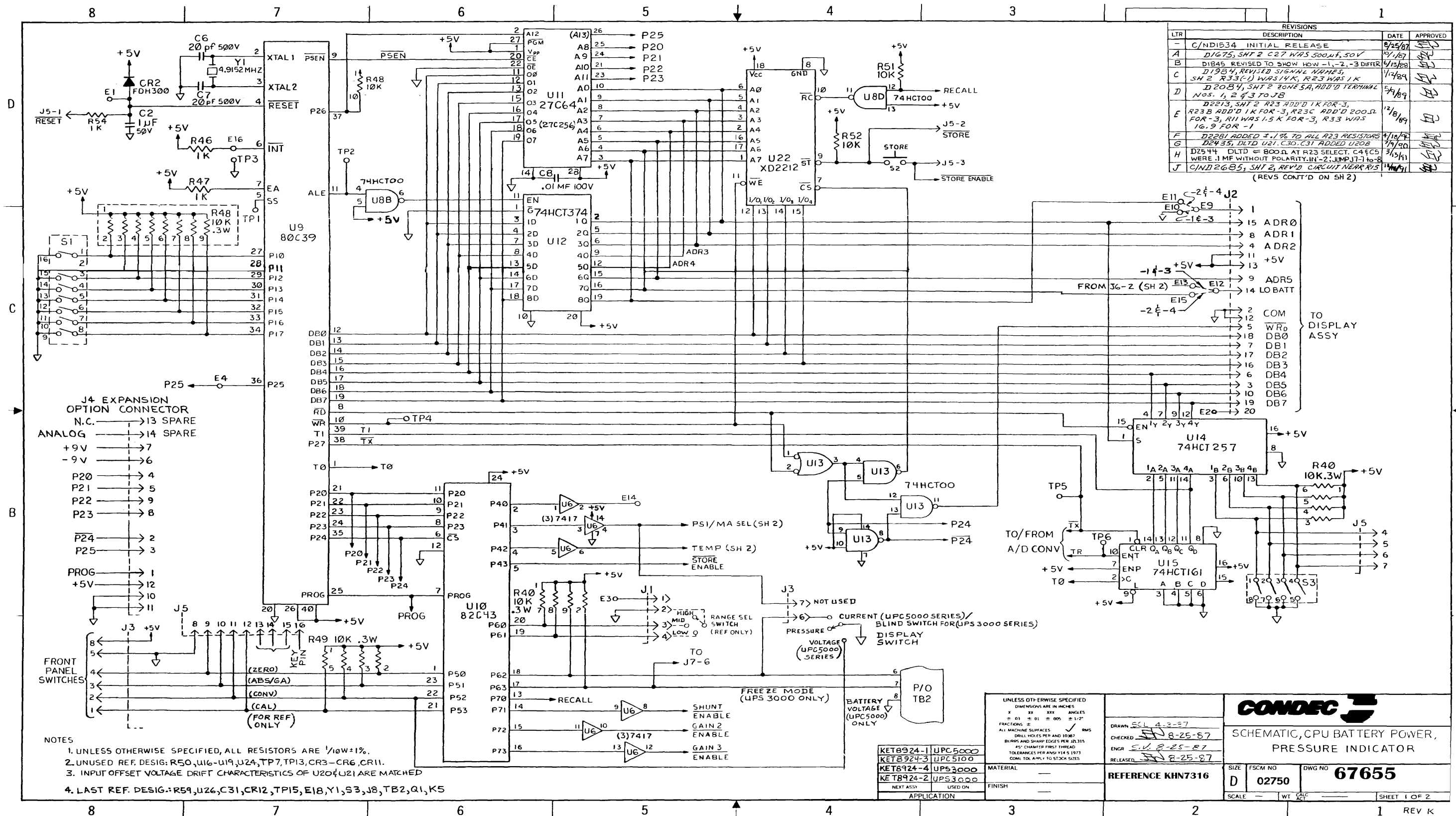
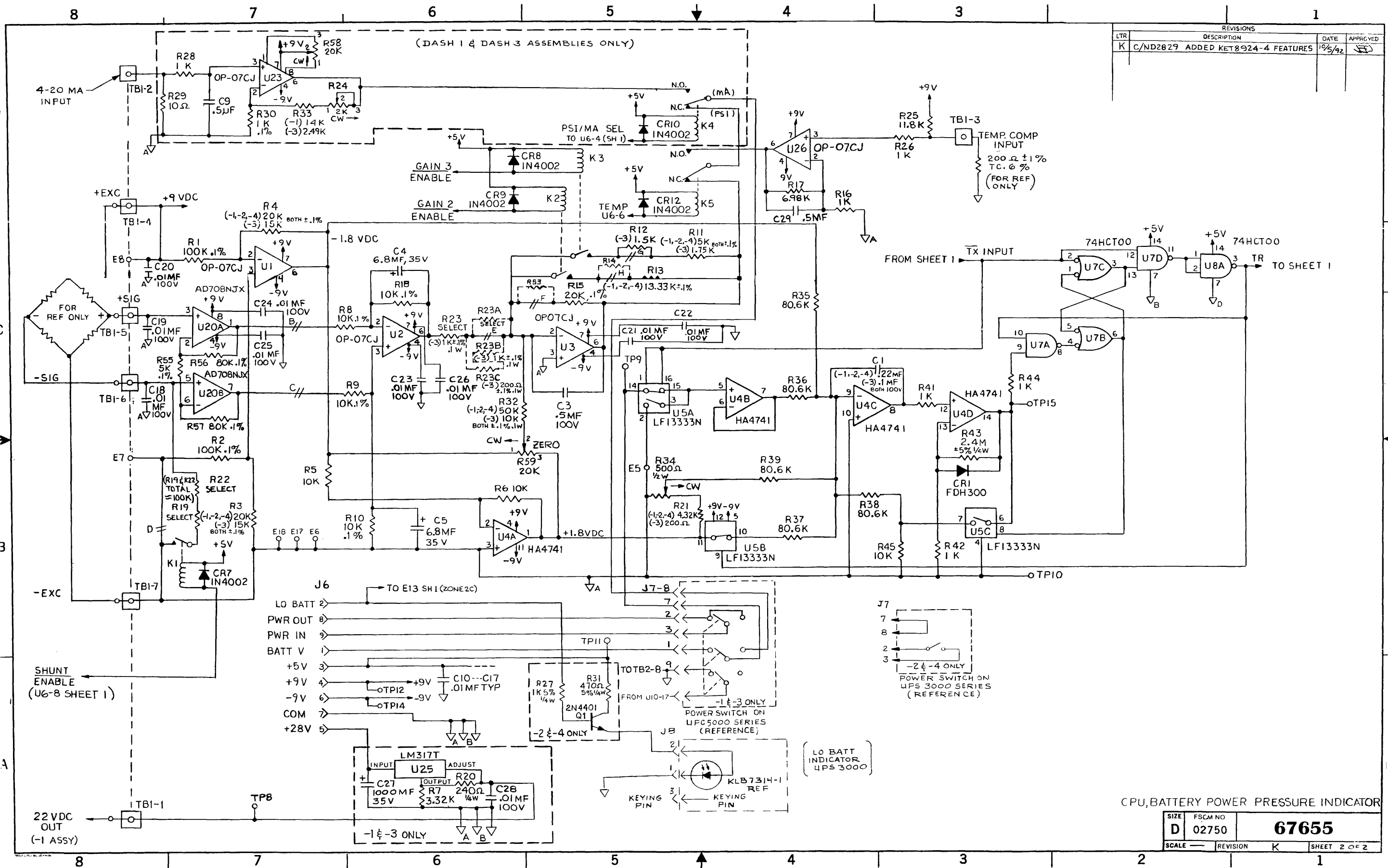

Figure 8-9. CPU SCHEMATIC, Sheet 1 (For Battery Units Only)



REVISIONS			
LTR	DESCRIPTION	DATE	APPROVED
K	C/ND2829 ADDED KET8924-4 FEATURES	10/5/92	[Signature]

Figure 8-10. CPU SCHEMATIC, Sheet 2 (For Battery Units Only)

UPC5100/UPC5110 Warranty and Return Policy

If possible, please save original packing material which is specifically designed for the unit. Should it be necessary to ship the unit back to the factory, a suitable shipping container must be used along with sufficient packing material. Do not put a shipping label on the unit as a shipping container. Some units have been severely damaged this way. This is a delicate, precision instrument. Any damage incurred because of poor packaging procedures will ultimately result in added service charges and longer turn-around times.



Vent all pressure lines and the nitrogen cylinder to the atmosphere before shipping.

When factory service is required, send in only the unit for repair. Retain fittings, manuals, etc. at your facility. However, if there is a problem with a particular part, send in that part with the unit.

If a unit is found to be defective, it may be returned to our repair facility at the following address:

CONDEC
3 SIMM LANE
DOOR D, UNIT 2A
NEWTOWN, CT 06470
ATTN: PRESSURE PRODUCTS/REPAIR LAB

Each unit's I.D. plate is stamped with a date code (week/year) prior to shipment. Our warranty is twelve (12) months from that date code and includes repair and/or replacement of the unit at our Newtown facilities at no charge. Units subjected to abuse or damaged by external influences, are not covered under warranty.

If the unit is found to be out of warranty, an evaluation charge of not less than fifty (U.S.) dollars (\$50.00) will be charged. Please note on any attached paperwork if a repair estimate is required or if there are any other specific instructions.

Please be explicit as to the nature of the problem and/or its symptoms. Your documentation will save needless time and expense. Also, please include a return shipping address (with a street address) and a contact name with fax and telephone numbers. Contact numbers are necessary to provide a job estimate and in case further questions arise at the factory.

UPC5100/UPC5110 Return Material Authorization Form

The repair lab is also equipped to do calibrations on our calibrators and pressure standards. Calibrations include a certification and are traceable to N.I.S.T.

Company Name:	
Street:	
City, State, ZIP:	
Telephone:	
Fax:	
Contact Person:	
MODEL NUMBER:	SERIAL NUMBER:
Problem with Unit (Please Be Specific):	
IS THIS A WARRANTY REPAIR?(<input type="checkbox"/>) YES(<input type="checkbox"/>) NO	
SHIP TO Address:	
Company Name:	
Street:	
City, State, ZIP:	
ATTN:	

CONDEC • 3 SIMM LANE • DOOR D, UNIT 2A • NEWTOWN, CT 06470
ATTN: PRESSURE PRODUCTS/REPAIR LAB
TEL: 888-295-8475 • FAX: 203-364-1556 or 715-234-6967
WEB SITE: www.4condec.com