

IR-H Series
HAND-HELD RADIATION
THERMOMETER
(Model: IR-HI, IR-HS, IR-HQH)

The word "INSTRUCTIONS" is rendered in a very large, bold, sans-serif font. The letters are filled with a dense dot pattern, similar to the CHINO logo background. To the left of the word, there is a vertical bar composed of many thin, parallel vertical lines of varying lengths, creating a barcode-like effect.

Always keep this instruction manual with the thermometer.

Please be sure to deliver this instruction manual to a person who uses the thermometer.

Request and notices

Software Ver. 2.0 □

Please read this instruction manual for using the thermometer correctly and safely.

Request to the operator of the thermometer

This instruction manual describes the maintenance of the thermometer, too.

Keep this instruction manual with the thermometer.

If you have unclear points or need technical assistance, please contact your sales agent of CHINO Corporation.

Notices

1. The information in this manual is subject to change without notice and does not represent a commitment on the part of CHINO Corporation.
2. No part of this manual may be reproduced or transmitted in any form or by any means, electronic or mechanical, including photocopying and recording, for any purpose other than the purchaser's personal use without permission of CHINO Corporation.
3. CHINO Corporation shall not be liable for any operation results.



Preface

**Software Ver. 2.0** □

To use the thermometer correctly and safely, please keep the following safety measures for the operation and storage of the thermometer.

This instruction manual is for the thermometer with the software version 1.40.
The software version of your thermometer is indicated in the label on the front side.
(Ref to [3.1.1 Front and both-side panels]).

1. Working conditions and environment

Make sure to press any keys until you hear an audible beep.

- The thermometer is designed as a handheld type. Use a tripod or a simple type universal head for long term or fixed mounting measurement.
- The working temperature range of the thermometer is 0 to 50 °C. (No dew condensation)
- Do not use the thermometer in dusty places, etc. Remove the dust after using it.
(For the cleaning of cover glass, refer to [8.3 Cleaning of cover glass] and, for the cleaning of external display and eyepiece cover, refer to [8.4 Cleaning of external display and eyepiece cover].)
- Be careful not to give vibration or impact to the thermometer.
- For preventing the consumption of the batteries, take off batteries when the thermometer is not used.

2. Storage

- Do not store the thermometer in hot and humid places. Make sure to store the thermometer with the lens cap. Recommend to store the thermometer in room temperature with a dry pill.
- Do not leave the thermometer in a car or its trunk room since the inside temperature will be extremely high in summer. The thermometer may have troubles.
- When the thermometer is not used for 2 weeks or more, take out the batteries from it. Otherwise, the thermometer may be damaged by liquid leakage of the batteries.
- When the thermometer has any trouble, please contact to your sales agent of CHINO Corporation.

3. Symbols in this instruction manual

The symbols shown below are used depending on important degrees for using the thermometer safely and avoiding unexpected situations.











Important degree	Symbols	Contents
1		This symbol is attached to a title for the sentence with Warning
2		For avoiding dangerous accidents (may cause death or serious injury) like as electrical shock, fires, or troubles/damages of the thermometer.
3		For avoiding injury or in physical damage to the thermometer.
4		Information that we suggest to read carefully.
5		Information that you can use as a reference.









Warnings and Cautions

Please use the thermometer correctly by keeping the following items.

In addition, please read this instruction manual carefully and keep it at the place where you can access easily.

The  mark indicates prohibited operations.

 Warning (May cause death or serious injury)	
	<p>Make sure not see the sun through the viewfinder of the thermometer. It may cause becoming blind.</p> <p>Never directly face the objective lens to the sun to protect the detecting element. </p> <p>For the measurement of high temperature objects, refer to the clause of "5.3 Cautions on measurement".</p>
	<p>Never operate the thermometer in places where combustible or volatile gas is existed. </p> <p>It is extremely dangerous to use the thermometer in such environment.</p>
	<p>Never put the batteries into fire, or never charge, short-circuit, heat or disassembly the batteries. </p> <p>Breaking or heating of the batteries may cause fire or injury.</p>
	<p>For the AC adapter (IR-VHR), make sure to use 100 to 240VAC. Other voltage may cause electrical shock, fire or trouble. </p> <p>Never touch the AC adapter or receptacles by wet hands.</p> <p>Never wet the AC adapter for avoiding fire.</p> <p>Wipe the dust on the AC adapter for avoiding fire.</p>
	<p>Never use the thermometer if it has been broken, smoking or nasty smelling. </p> <p>These may cause fire. When the thermometer is broken, smoking, or nasty smelling, turn the power supply switch off at once and take out the batteries, and contact to a sales agent of CHINO Corporation.</p>

 Caution (May cause injury or physical damage)	
	<p>Do not use other batteries than the batteries specified. </p> <p>Load the batteries so that their polarities meet the polarity marks on the battery case. Different polarities may cause fire, injury or damage by burst or liquid leakage of the batteries.</p>
	<p>Do not walk while sighting through the viewfinder of the thermometer. </p> <p>It may cause accidents like as falling down.</p>
	<p>Never take the thermometer apart or convert it. </p> <p>These may cause trouble and danger.</p>
	<p>Read the entire contents in this instruction manual to have the thermometer function perfectly.</p>
	<p>Dispose the batteries used to places specified with the disposal procedure specified.</p>

CONTENTS

Software Ver. 2.0□

1. INTRODUCTION	1
1.1 GENERAL	1
1.2 CONFIGURATION	1
2. MODEL AND ACCESSORIES	1
2.1 MODEL	1
2.2 ACCESSORIES	1
3. NAMES AND FUNCTIONS OF COMPONENT PARTS.....	2
3.1 VIEWS	2
3.1.1 Front and both-side panels	2
3.1.2 Connector cover inside	2
3.1.3 Functions	2
3.1.4 External display	3
3.1.5 Viewfinder	3
3.1.6 Functions of keys	3
3.1.7 Markers	3
4. PREPARATION FOR MEASUREMENT	4
4.1 LOADING BATTERIES	4
4.2 DISTANCE AND DIAMETER.....	4
5. MEASURING.....	6
5.1 STANDARD MEASUREMENT MODE.....	6
5.2 CONTINUOUS MEASUREMENT MODE	7
5.2.1 Start of continuous measurement.....	7
5.2.2 Cancellation of continuous measurement.....	7
5.3 CAUTION ON MEASUREMENT 	8
5.4 EMISSIVITY PROGRAMMING	8
5.5 EMISSIVITY PROGRAMMING BY THERMOCOUPLE	9
5.6 PARAMETERS SELECTION.....	10
5.6.1 Signal modulation mode selection	11
5.6.2 Memory mode selection.....	11
5.6.3 Communications mode selection	12
5.6.4 Temperature unit selection.....	12
5.6.5 Thermocouple measurement selection.....	13
5.6.6 2-color type/single color wide range type selection	13
5.7 PARAMETERS PROGRAMMING	14
5.7.1 Low alarm setpoint programming	14
5.7.2 High alarm setpoint programming	15
5.7.3 Modulation ratio selection	15
5.7.3 1) Modulation time constant selection (for dLEy selected).....	16
5.7.3 2) Damping degree selection (for PEAK selected).....	16
5.7.4 Interval time programming for automatic data storage.....	16
6. TEMPERATURE DATA STORAGE.....	17
6.1 MANUAL DATA STORAGE MODE.....	17
6.2 AUTOMATIC DATA STORAGE MODE	19

CONTENTS

Software Ver. 2.0□

6.3 DATA STORAGE NUMBER PROGRAMMING AND REPLAY OF STORED DATA	22
6.3.1 Data storage number programming (Manual data storage mode)	22
6.3.2 Data storage number programming (Automatic data storage mode)	23
6.3.3 Recalling of stored data (Manual data storage mode)	24
6.3.4 Recalling of stored data (Automatic data storage mode)	26
6.4 MEMORY FULL	28
6.5 ERASING ALL STORED DATA	29
7. USER CALIBRATION	30
7.1 USER CALIBRATION	30
8. MAINTENANCE AND CHECK	33
8.1 SELF-DIAGNOSTIC FUNCTION	33
8.2 STORAGE	33
8.3 CLEANING OF OBJECTIVE LENS.....	33
8.4 CLEANING OF EXTERNAL DISPLAY AND EYEPIECE COVER.....	33
9. ACCESSORIES	34
9.1 THERMOCOUPLE	34
9.2 AC ADAPTER (MODEL IR-VHRA) 	34
9.3 TRIPOD (MODEL IR-ZBMT) AND UNIVERSAL HEAD (MODEL IR-VMS)	34
9.4 DATA LOGGING SOFTWARE	34
10. LIST OF STARTING UP MODES.....	35
10.1 MODES AT START UP	35
10.2 TABLE OF SCREENS	35
10.3 MEASURING PARAMETER PROGRAMMING/DISPLAY	35
10.3.1 Emissivity programming/display	35
10.3.2 Data storage number programming/dispay	36
10.4 SYSTEM SETTINGS	36
11. GENERAL SPECIFICATIONS	37
11.1 SPECIFICATIONS	37
11.2 OUTSIDE DIMENSIONS	37
12. EMISSIVITY TABLE	38
12.1 EMISSIVITY TABLE.....	38
12.1.1 Emissivity table (= 0.65μm)	38
12.1.2 Emissivity table (= 0.9μm)	39
12.1.3 Emissivity table (= 1.55μm)	39

Note: Make sure to read the items with the mark of 

The articles of **Warning** are included.

1. Introduction

1.1 General

The IR-H series is small and lightweight handheld radiation thermometers with a clear viewfinder. The direct viewfinder enables to measure small objects with distance. With the digital display in the viewfinder, you can see a measured value while sighting to an object.

Three kinds of models are available, Model IR-HQH with both functions of [2-color type + Single color wide range type] as a single unit, Single color type Model IR-HI for medium temperature, and Single color type IR-HS for high temperature.

You can process the stored data by using a data logging software (IR-VXG1E ... separate purchase required ... Ref to [9.4 Data Logging Software IR-VXG1E]).

1.2 Configuration

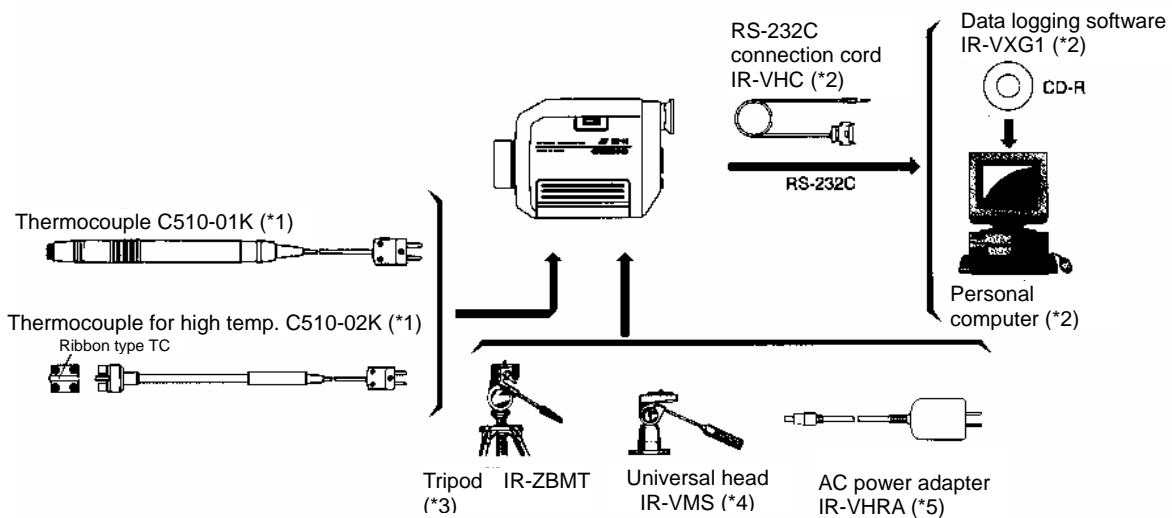

CE EN61326
 Emission: Class B
 Immunity: Table 1 - minimum immunity requirement

*1, *2, *3, *4, *5: Separate purchase is required.

*5 : For a thermometer with CE-marking, mount an attached ferrite core to a connection cord at a nearest place to the thermometer.

2. Model and accessories

2.1 Model

IR-H

└ Thermometer types

- I : Single color type for medium temperature (300 to 1000°C)
- S : Single color type for high temperature (600 to 2000°C)
- QH : High functional type (600 to 2000°C for 2-color type, 400 to 3000°C for single color wide range type)

2.2 Accessories

Names	Quantity	Remarks	Names	Quantity	Remarks
AA (UM-3) battery	2	Alkaline	Inspection certificate	1	
Instruction manual	1	This manual			

3. Names and functions of component parts

3.1 Views

3.1.1 Front and both-side panels

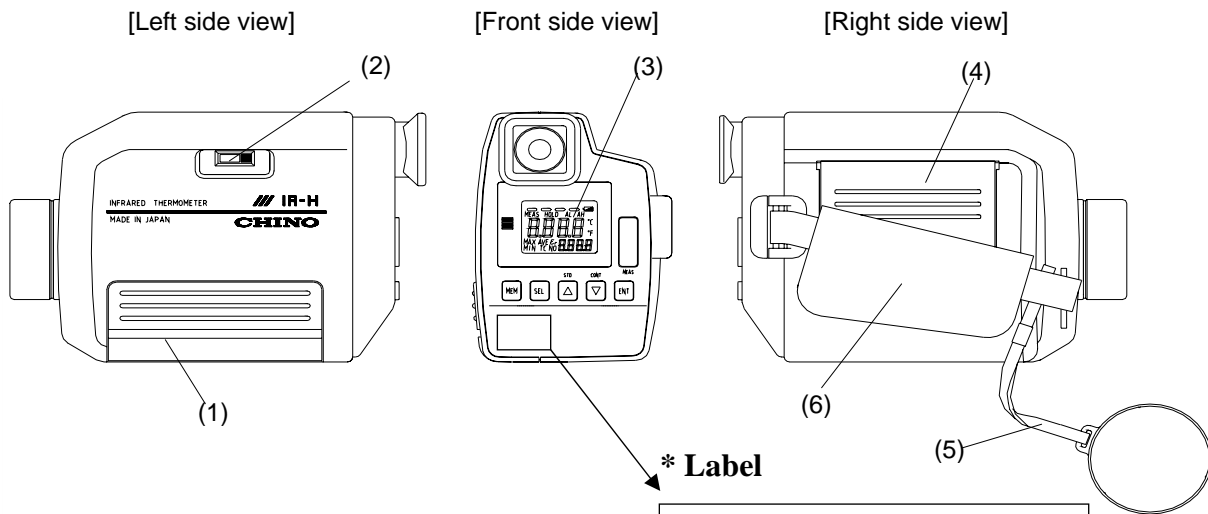

3.1.2 Connector cover inside

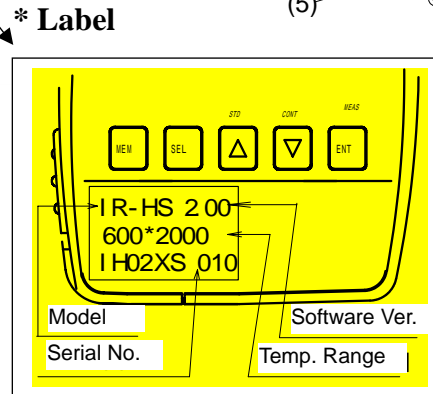
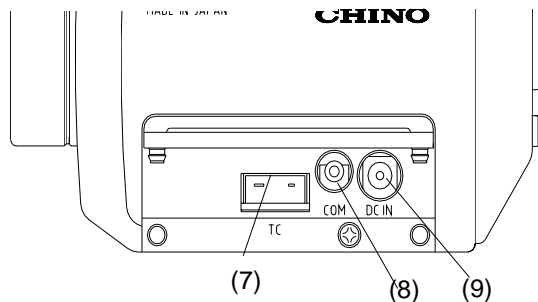

* Confirm the software version of your thermometer is 2.0□

3.1.3 Functions

Names	Functions
(1) Connector cover	For the connectors of 7, 8 and 9 shown above. Open the cover from down side for the connection to the connectors.
(2) Beam attenuation filter selector knob	For setting a beam attenuation filter to ON (beam attenuation side). For protecting your eyes when an object with high temperature over 1500°C is measured or when you feel glare, measure the object through the beam attenuation filter by setting the beam attenuation filter selector knob to the beam attenuation side. (Ref: [5.3 Cautions on measurement])
(3) External display	A measured value and parameters are displayed.
(4) Battery cover	Remove it by lightly pushing both sides of the triangle mark and sliding it to the arrow direction. (Ref: [4.1 Loading batteries])
(5) Lens cap	For protecting the objective lens.
(6) Side band	For supporting the thermometer. Adjust the length of band for your hand.
(7) Thermocouple connector	For connecting to a thermocouple. (Ref: [9.1 Thermocouple]) Caution Thermocouples except the models listed in [9.1 Thermocouple] cannot be connected.]
8:PC connecting jack	For connecting the communications cable. (Ref: [9.4 Data Logging Software])
9:DC power supply jack	For connecting to the AC adapter. (Ref: [9.2 AC Adapter])

3. Names and functions of component parts

3.1.4 External display

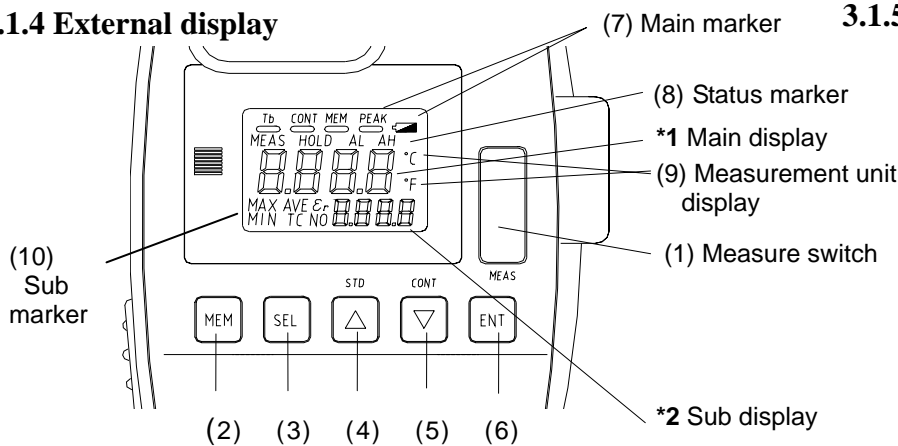

3.1.5 Viewfinder

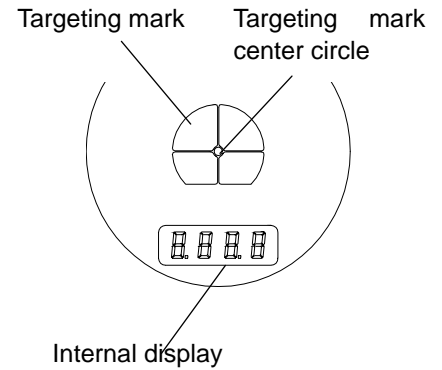

***1:Main display:** Displays the measured value in the measurement mode or a parameter in the parameter selecting/programming mode.
***2:Sub display:** Displays the data selected by **[SEL]** key in the measurement mode or a parameter item in the parameter selecting/programming mode.

3.1.6 Functions of keys

Keys	Functions	Indications
(1) Measure Switch	Turns on the power supply and starts/stops a measurement. (The power supply will be automatically turned off if any key is not pressed for 30 seconds in the hold mode.)	[MEAS]
(2) Memory key	Changes from the standard or continuous measurement mode to the data storage mode, or vice versa.	[MEM]
(3) Select key	Selects a data to be displayed in the sub display in measurement mode or a selecting/programming item in the parameter selection/programming mode.	[SEL]
(4) Up key Down key	Selects a parameter item or changes the numerical figure at a digit in the parameter selection/programming mode.	□ □
(5) Entry key	Stores the parameter selected/programmed in the parameter selection/programming mode or the measured value in the manual data storage mode. (This key is not used in the automatic data storage mode.)	[ENT]

3.1.7 Markers

	Markers	Major functions	Indications
(7)Main marker	Tb	Not used	"Tb"
	CONT	The "—" mark under "CONT" will light in the continuous measurement mode.	"CONT"
	MEM	The "—" mark under the "MEM" will light in the data storage mode.	"MEM"
	PEAK	When the PEAK is selected in the signal modulation mode selection, the "—" mark under the "PEAK" will light.	"PEAK"
	☐	Will blink for low batteries.	
(8)Status marker	MEAS	Will light in the measurement mode.	"MEAS"
	HOLD	Will light in the hold mode.	"HOLD"
	AL	Will light when the low alarm is activated.	"AL"
	AH	Will light when the high alarm is activated.	"AH"
(9)Unit	°C	Will light when a temperature is displayed in Celsius.	"°C"
	°F	Will light when a temperature is displayed in Fahrenheit.	"°F"
(10)Sub marker	MAX	Will light when the sub display shows a maximum temperature.	"MAX"
	MIN	Will light when the sub display shows a minimum temperature.	"MIN"
	AVE	Will light when the sub display shows an average temperature.	"AVE"
	TC	Will light when the sub display shows a temperature measured by a thermocouple.	"TC"
	(r)	Will light when the sub display shows an emissivity (ratio). Single color type is the emissivity () and 2-color type is the emissivity ratio (r).	" "or" r"
	NO	Will light when the sub display shows a data storage number.	"NO"

4. Preparation for measurement

4.1 Loading batteries

- Remove the battery cover. Remove it by lightly pushing both sides of  mark and sliding it to the arrow direction.

Caution

- Load two batteries with proper polarities.

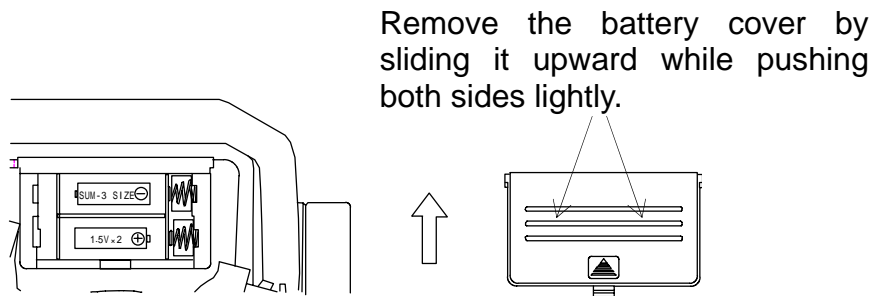

Caution

- Battery life**
The battery warning maker "  " will blink when the battery capacity becomes lower. Replace the batteries (Alkaline AA or UM-3 batteries). (Ref:[3.1.7 Markers])
When the marker disappears, replace the batteries (Alkaline AA or UM-3 batteries), too.
- Caution on removing the batteries**
Make sure to remove the batteries from the [no-spring] side.
- Battery replacement**
Make sure to load the batteries to the [spring] side first.
Replace 2 batteries together.

4. Preparation for measurement

4.2 Distance and diameter

The relation of measuring distance and measuring diameter is shown below.

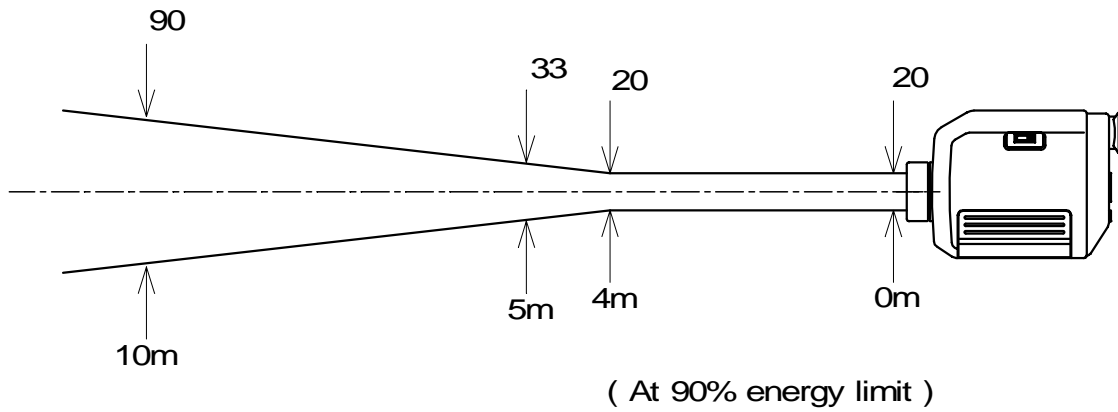

Remarks

- The measuring diameter is fixed to $\varnothing 20\text{mm}$ for the measuring distance up to 4m.
- For the measuring distance shorter than 3m, make sure to have the measuring diameter larger than the targeting mark.

4.3 Targeting

For the accurate temperature measurement, target at an object correctly

The following figures (1), (2), and (3) show the correct targeting based on the relation of the measuring distance and the measuring diameter.

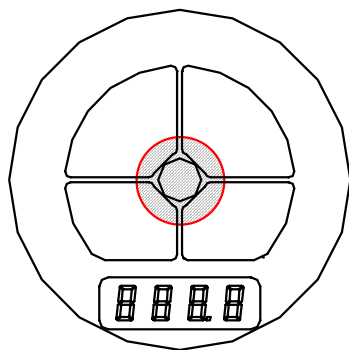

(1) For the measurement distance is shorter than 3m

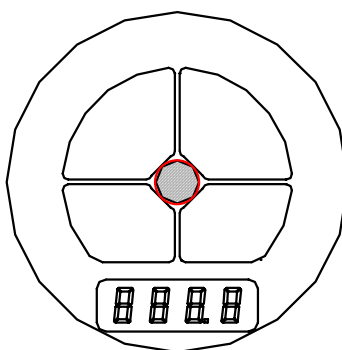

(2) For the measurement distance is about 3m

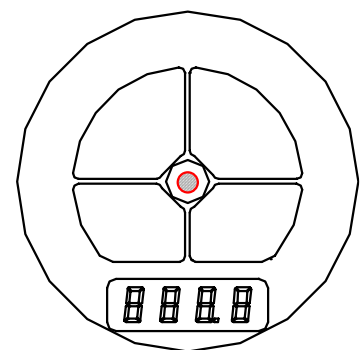

(3) For the measurement distance is longer than 3m

(1) For the measurement distance is shorter than 3m

Measurement diameter becomes “larger” than the targeting mark.

(2) For the measurement distance is about 3m.

The measurement diameter and the inner side of the targeting mark are almost “same”.

(3) For the measurement distance is longer than 3m

Measurement diameter becomes “smaller” than the targeting mark.

5. Measuring *Make sure to press any keys until you hear an audible beep.

(Common to [5.1 Standard measurement mode] and [5.2 Continuous measurement mode])

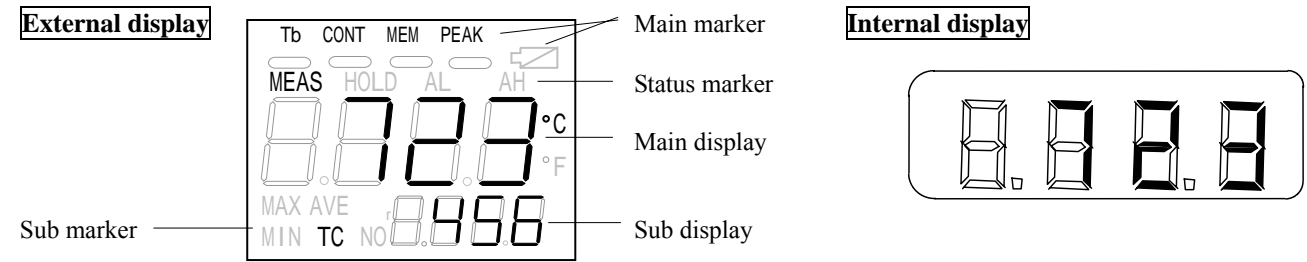

*** Data in the sub display (Common to [5.1 Standard measurement mode] and [5.2 Continuous measurement mode])**

Sub marker	Data displayed in sub display
ε (εr)	Emissivity (ε) for single color type, Emissivity ratio (εr) for 2-color type
TC	Temperature data measured by a thermocouple is displayed when you select on (enable) in [5.6.5 Thermocouple measurement selection]. Refer to the following Remarks .
MIN	Minimum temperature during measurement (during the status marker "MEAS" lights)
MAX	Maximum temperature during measurement (during the status marker "MEAS" lights)
AVE	Average temperature during measurement (during the status marker "MEAS" lights) (Moving average of 25 points)
NO	Stored data storage number. Lights in the [5.2 storage mode] only.

5.1 Standard measurement mode

This mode is for measurement with holding the thermometer by hands.

- Sight through the viewfinder and match the center circle of the targeting circle to the center of object measured.
- Press **MEAS** key for about 1 second to turn on the power supply and start a measurement. The temperature measured will be displayed in the internal and external displays, and the status marker "MEAS" will light in the external display.
(The measurement is continued during **MEAS** key is being pressed.)
- Select the data to be displayed in the sub display by pressing **SEL** key if necessary.

Remarks • "oFL" will be displayed in the main and sub displays if the temperature data measured is higher than [the measuring range + 20°C (or +36°F)] or "uFL" will be displayed if it is lower than [the measuring range - 20°C (or -36°F)].

Remarks • In [5.6.5 Thermocouple measurement selection], when you select **on** (enable) and display "TC" in the sub marker by **SEL** key, "oFL" will be displayed in the sub display if the temperature data measured by the thermocouple is higher than 1220°C (or 2228°F). If the temperature is lower than -50°C (or -58°F), "uFL" will be displayed.
• On the condition mentioned above, if the thermocouple is disconnected, "uFL" will be displayed in the sub display.

- By releasing **MEAS** key, the measurement will stop and the measured value will be held. The status marker "MEAS" will disappear and "HOLD" will light.

Remarks • The internal display will disappear in 10 seconds in the hold mode and the power supply will be automatically turned off if any key is not pressed for 30 seconds in the hold mode.

5. Measuring

*Make sure to press any keys until you hear an audible beep.

5.2 Continuous measurement mode

5.2.1 Start of continuous measurement

This mode is for continuous measurement by fixing the thermometer on a tripod or a universal head.

- Sight through the viewfinder and match the center circle of the targeting circle to the center of object measured
- For the continuous measurement mode, press **MEAS** key while pressing key. As soon as all segments of the external display (Ref. 3.1.4 [External display]) light, release **MEAS** key. The "—" mark under the main marker "CONT" and the status marker "HOLD" will light.

Caution

- The status marker "MEAS" will light depending on its releasing timing of **MEAS** key. In this case, press **MEAS** key only again to light the status marker "HOLD".

- Press **MEAS** key to start the continuous measurement. The status marker "HOLD" will disappear and the status marker "MEAS" will light.

Remarks

- "oFL" will be displayed in the main and sub displays if the temperature data measured is higher than [the measuring range + 20°C (or +36°F)] or "uFL" will be displayed if it is lower than [the measuring range - 20°C (or -36°F)].

Remarks

- In [5.6.5 Thermocouple measurement selection], when you select **on** (enable) and display "TC" in the sub marker by **SEL** key, "oFL" will be displayed in the sub display if the temperature data measured by the thermocouple is higher than 1220°C (or 2228°F). If the temperature is lower than -50°C (or -58°F), "uFL" will be displayed.
- On the condition mentioned above, if the thermocouple is disconnected, "oFL" will be displayed in the sub display.

Remarks

- The internal display will disappear in 10 seconds after the measurement starts.

- Press **MEAS** key again to hold the measured value. The status marker "HOLD" will light.

Remarks

- The power supply will be automatically turned off if any key is not pressed for 30 seconds in the hold mode.

Reference

- The continuous measurement shorts the battery life. We recommend to use the AC adapter (Model: IR-VHRA ... separate purchase required).

5.2.2 Cancellation of continuous measurement

- For canceling the continuous measurement mode, press **MEAS** key for about 1 second while pressing key on the condition that the power supply is off. Confirm that the "—" mark under the main marker "CONT" disappeared.

5. Measuring

*Make sure to press any keys until you hear an audible beep.

5.3 Cautions on measurement

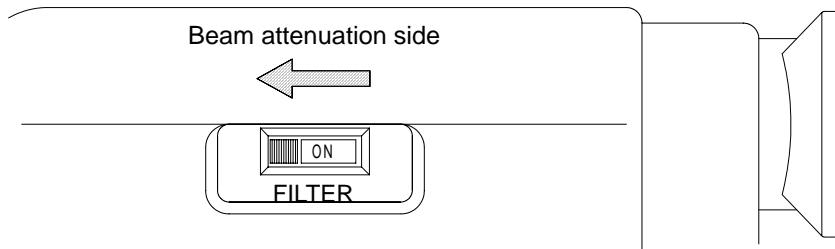

Warning

- Never directly sight the objective lens of the thermometer to the sunlight for protecting your eyes and a detecting element.

Warning

- For the measurement of object exceeding 1500°C, make sure to set the beam attenuation filter selector knob to "ON" (beam attenuation side) for protecting your eyes. (Refer to the above figure.)
- However, when you feel glare on the measurement of objects lower than 1500°C, set the beam attenuation filter selector knob to "ON" (beam attenuation side). (Refer to the above figure.)

Caution

- **Light path**
Be careful not to introduce water drops, dust particles, smoke, steam, or other foreign substances into the light path between the object measured and the objective lens of the thermometer.
- **Interference causing high indication**
Be careful not to apply the direct sunlight, light of an incandescent lamp, flame or other thermal radiation to the object measured and the objective lens of the thermometer.

5.4 Emissivity programming

If the emissivity of object measured is low, the temperature displayed becomes lower than the exact temperature and the emissivity is to be compensated.

- Press **MEAS** key for about 1 second to turn on the power supply and then release **MEAS** key. The status marker "HOLD" will light.
- In the hold mode, press **SEL** key several times to enter the emissivity programming mode " " (" r" for 2-color type) in the sub marker. (Ref: [3.1.7 Markers]).

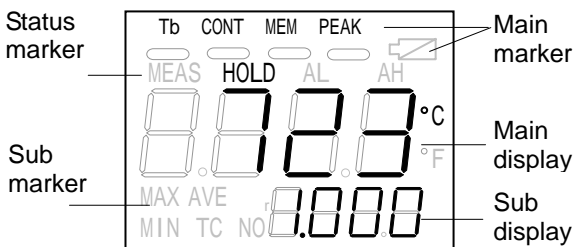

- By pressing either or key, the least significant digit of 4-digit numeric will blink for programming it.
- Program the desired figure by pressing or key.
- Press **ENT** key. The blinking will stop and the programming digit will shift to the next higher digit.

- Repeat the above procedure up to the most significant digit for programming the emissivity (4 digits).
- By pressing **ENT** key at the most significant digit, the programming of emissivity will be completed.

Remarks

- The programming range is **1.900 to 0.100**. (0.001 increment)
- The default is "1.000".

5. Measuring

*Make sure to press any keys until you hear an audible beep.

5.4 Emissivity programming

Caution

- The emissivity programming is disabled in the data storage mode (when the " — " mark under the main marker "MEM" lights). For canceling the data storage mode, press **MEM** key. The " — ' mark under the main marker "MEM" will disappear.

Reference

- In [5.6.5 Thermocouple measurement selection], when you select **on** (enable) and the thermocouple is disconnected, "oFL" will be displayed in the sub display.

5.5 Emissivity programming by thermocouple

The thermometer can be used as a surface thermometer by connecting a K type thermocouple. Further the emissivity of the thermometer can be automatically programmed by assuming that the surface temperature measured by the thermocouple is a true temperature

Remarks

- The default parameter of thermocouple input is **oFF** (thermocouple measurement disabled.).
- For the programming it to **on** (thermocouple measurement enabled), refer to [5.6 Programming parameters] and [5.6.5 Thermocouple measurement selection].

- Press **MEAS** key for about 1 second to turn on the power supply and then release to **MEAS** key. The status marker "HOLD" will light.
- Press **SEL** key to display "TC" (thermocouple input mode) in the sub marker. (Ref: [3.1.7 Markers]).
- Press **MEAS** key to take a measurement by the thermometer and a thermocouple simultaneously.
- After the measurement, the emissivity will be automatically programmed by pressing **ENT** key in the hold mode.

Caution

- The emissivity programming is disabled in the data storage mode (when the " — ' mark under the main marker "MEM" lights). For canceling the data storage mode, press **MEM** key.

Reference

- If you know the emissivity of object measured, program to its value.
- If the emissivity is unknown, measure the temperature of object by a thermocouple and program the emissivity to display the same temperature.
- The reference table of emissivity is shown in [12. Emissivity table]

5. Measuring *Make sure to press any keys until you hear an audible beep.

5.6 Parameters selection (This paragraph explains the items highlighted.)

The thermometer provides parameters for measurements as shown in the list below. By referring to the list, select or program the parameters.

Parameter item	Sub display	Parameter	Default	Paragraph
Low temperature alarm programming	AL	oFF, 300 to 1000°C/572 to 1832°F (IR-HI) oFF, 600 to 2000°C/1112 to 3632°F (IR-HS) oFF, 400 to 3000°C/752 to 5432°F (IR-HQH)	oFF	5.7.1
High temperature alarm programming	AH	oFF, 300 to 1000°C/572 to 1832°F (IR-HI) oFF, 600 to 2000°C/1112 to 3632°F (IR-HS) oFF, 400 to 3000°C/752 to 5432°F (IR-HQH)	oFF	5.7.2
Signal modulation mode selection	modu	dELy, PEAk	dELy	5.6.1
Modulation ratio selection	tAu dEc	0.0, 0.2, 0.5, 1.0 (second) 0, 2, 5, 10°C (°F)/second	0.0s 0°C/s	5.7.3
Data storage mode selection	mmod	mAn, int	mAn	5.6.2
Data storage interval programming	int	1 to 7200 seconds	60s	5.7.4
All stored data erasing	AdEL	no, yES	no	6.5
Communications mode selection	Com	trnS, Com	trnS	5.6.3
Measuring unit selection	Unit	C, F	C	5.6.4
Thermocouple enable/disable selection	TC	oFF, on	oFF	5.6.5
2-color/single color wide selection *	CoLr	2, 1	2	5.6.6

* The 2-color/single color wide selection is displayed in Model IR-HQH only.

- Press **MEAS** key for about 1 second to turn on the power supply and then release **MEAS** key. The status marker "HOLD" will light.
- Press **SEL** key for about 2 seconds in the hold mode to move to the programming mode. A parameter will be displayed in the main display and its item will be displayed in the sub display.
- Press **SEL** key for selecting a parameter item. (Ref: [10.4 System settings])
- For the selecting or programming procedure of the above parameters, refer from [5.6.1 Signal modulation mode selection] to [5.6.6 2-color type /single color wide range type selection].

Remarks • If **SEL** key is pressed for 2 seconds in the programming mode or if any key is not pressed for 1 minute, the thermometer will return to the measurement mode.

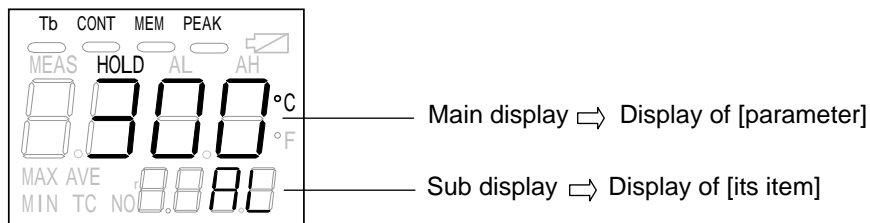

« Programming mode screen »

5. Measuring

*Make sure to press any keys until you hear an audible beep.

5.6.1 Signal modulation mode selection

Maximum value and average value can be extracted continuously from the measurement signal (real signal).

- Press **MEAS** key for about 1 second to turn on the power supply and then release **MEAS** key. The status marker "HOLD" will light.
- Press **SEL** key for about 2 seconds to in the hold mode to move to the programming mode. A parameter will be displayed in the main display and its item will be displayed in the sub display.
- Press **SEL** key to display "modu" in the sub display.
- By pressing or key, either "dELy" (average value) or "PEAk" (maximum value) will blink in the main display.

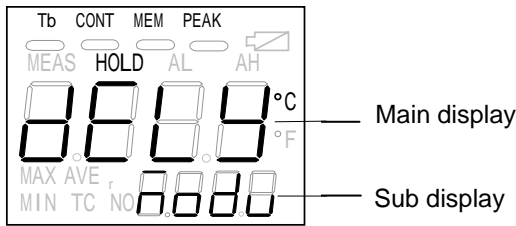

- Select your desired mode and press **ENT** key.
- By storing the **dELy**, the "dELy" will light in the main display. By storing the **PEAk**, the "PEAk" will light in the main display and the "—" mark will light under the main marker "PEAk".

dELy	The temperature displayed is based on the first-order lag signal selected in [5.7.3-1 Modulation ratio selection].
PEAk	When the temperature measured increases, its displayed value is based on the real signal. When the temperature measured decreases, its displayed value is based on the value selected in [5.7.3-2 Damping degree selection].

Remarks • The default is "dELy".

5.6.2 Data storage mode selection

MAAn	Manual data storage mode: Stores the data each time ENT button is pressed.
Int	Automatic data storage mode: Stores the data at the interval time programmed.

For storing the measured data, select the manual data storage mode or the automatic data storage mode.

Reference • This data storage selection is effective in the data storage mode. (Ref. [6.1 Manual data storage mode] and [6.2 Automatic data storage mode])

- Press **MEAS** key for about 1 second to turn on the power supply and then release **MEAS** key. The status marker "HOLD" will light.
- Press **SEL** key for about 2 seconds in the hold mode to move to the programming mode. A parameter will be displayed in the main display and its item will be displayed in the sub display.

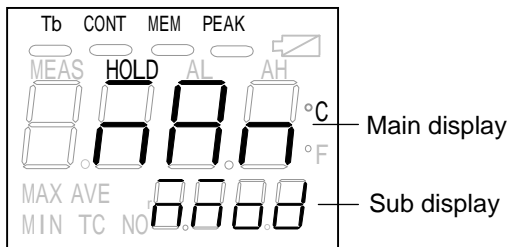

- Press **SEL** key to display "mmod" in the sub display.
- By pressing or key, either "mAn" (manual data storage mode) or "int" (automatic data storage mode) will blink in the main display.
- Select your desired mode and press **ENT** key.

Remarks • The default is "mAn" (manual data storage mode).

5. Measuring

*Make sure to press any keys until you hear an audible beep.

5.6.3 Communications mode selection

Select one-way communications to or both-way communications with a personal computer.

- Press **MEAS** key for about 1 second to turn on the power supply and then release **MEAS** key. The status marker "HOLD" will light.

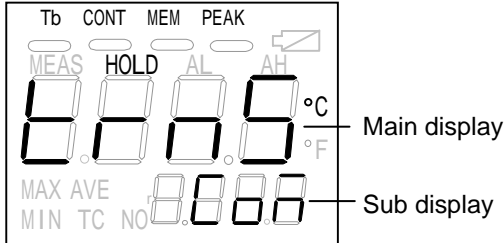

- Press **SEL** key for 2 seconds in the hold mode to move to the programming mode. A parameter will be displayed in the main display and its item will be displayed in the sub display.
- Press **SEL** key to display "Com" in the sub display.
- By pressing or key, either "trnS" (one-way communications) or "Com" (both-way communications) will blink in the main display.
- Select your desired mode and press **ENT** key.

TrnS	<ul style="list-style-type: none"> • This mode is used for monitoring, by a personal computer, of emissivity, temperature and thermocouple temperature as the measured data. • The transmission of data is one-way from the thermometer to the personal computer when MEAS key is released in the standard measurement mode and at every 0.2 second in the continuous measurement mode.
Com	<ul style="list-style-type: none"> • This mode is used to see the display and settings of parameters by a personal computer in addition to the monitoring in "trnS" mode, • This mode is both-way communications by sending a response from the thermometer against the communications command from a personal computer

Remarks • The default is "trnS" (one-way transmission from thermometer).

5.6.4 Temperature unit selection

Select °C or °F for measuring temperature unit.

- Press **MEAS** key for about 1 second to turn on the power supply and then release **MEAS** key. The status marker "HOLD" will light.

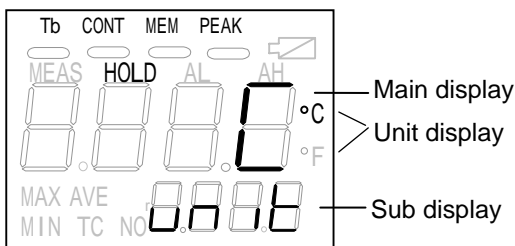

- Press **SEL** key for about 2 seconds in the hold mode to move to the programming mode. A parameter will be displayed in the main display and its item will be displayed in the sub display.
- Press **SEL** key to display "unit" in the sub display.
- By pressing or key, either "C" (°C) or "F" (°F) will blink in the main display.
- Select your desired mode and press **ENT** key.

Remarks • The default is "C" (°C).

5. Measuring

*Make sure to press any keys until you hear an audible beep.

5.6.5 Thermocouple measurement selection (Separate purchase of a K type T/C is required.)

Select to measure by a thermocouple. (Ref: [9.1 Thermocouple])

- Press **MEAS** key for about 1 second to turn on the power supply and then release **MEAS** key. The status marker "HOLD" will light.
- Press **SEL** key for about 2 seconds in the hold mode to move to the programming mode. A parameter will be displayed in the main display and its item will be displayed in the sub display.

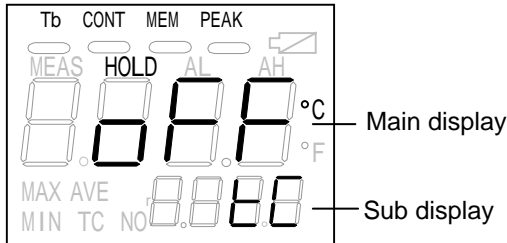

- Press **SEL** key to display "tC" in the sub display.
- By pressing or key, either "oFF" (disable) or "on" (enable) will blink in the main display.
- Select your desired mode and press **ENT** key.

Remarks • The default is "oFF" (disable).

5.6.6 2-color type/single color wide range type selection (* High functional type IR-HQH only)

Select a measurement mode by 2-color type or single color wide range type in Model IR-HQH.

- Press **MEAS** key for about 1 second to turn on the power supply and then release **MEAS** key. The status marker "HOLD" will light.
- Press **SEL** key for about 2 seconds in the hold mode to move to the programming mode. A parameter will be displayed in the main display and its item will be displayed in the sub display.

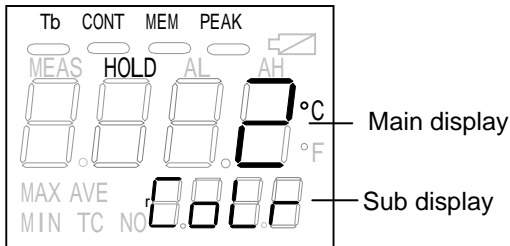

- Press **SEL** key to display "CoLr" in the sub display.
- By pressing or key, either "2" (2-color type) or "1" (single color wide range type) will blink in the main display. Select your desired mode and press **ENT** key.

Remarks • The default is "2" (2-color type).

5. Measuring *Make sure to press any keys until you hear an audible beep.

5.7 Parameters programming

The thermometer provides parameters for measurements as shown in the list below.

By referring to the list, program the parameters.

Parameter item	Sub display	Parameter	Default	Paragraph
Low temperature alarm programming	AL	oFF, 300 to 1000°C/572 to 1832°F (IR-HI) oFF, 600 to 2000°C/1112 to 3632°F (IR-HS) oFF, 400 to 3000°C/752 to 5432°F (IR-HQH)	oFF	5.7.1
High temperature alarm programming	AH	oFF, 300 to 1000°C/572 to 1832°F (IR-HI) oFF, 600 to 2000°C/1112 to 3632°F (IR-HS) oFF, 400 to 3000°C/752 to 5432°F (IR-HQH)	oFF	5.7.2
Signal modulation mode selection	modu	dELy, PEAK	dELy	5.6.1
Modulation ratio selection *	tAu dEc	0.0, 0.2, 0.5, 1.0 (second) 0, 2, 5, 10°C (°F)/second	0.0s 0°C/s	5.7.3
Data storage mode selection	mmod	mAn, int	mAn	5.6.2
Data storage interval programming	int	1 to 7200 seconds	60s	5.7.4
All stored data erasing	AdEL	no, yES	no	6.5
Communications mode selection	Com	trnS, Com	trnS	5.6.3
Measuring unit selection	Unit	C, F	C	5.6.4
Thermocouple enable/disable selection	TC	oFF, on	oFF	5.6.5
2-color/single color wide selection	CoLr	2, 1	2	5.6.6

* The modulation ratio selection differs by the selection of the signal modulation mode.
(Ref: [5.6.1 Signal modulation mode selection])

5.7.1 Low alarm setpoint programming

This programming is for a judgment of low alarm during measurement.

When the low alarm is judged, the status marker "AL" will light and the buzzer will sound. When the "oFF" is selected, neither the alarm judgment can be executed nor the buzzer can be sound.

- Press **MEAS** key for about 1 second to turn on the power supply and then release **MEAS** key. The status marker "HOLD" will light.
- Press **SEL** key for about 2 seconds in the hold mode to move to the programming mode. A parameter will be displayed in the main display and its item will be displayed in the sub display.
- Press **SEL** key to display "AL" in the sub display.
- By pressing key, the least significant digit will blink for programming it.

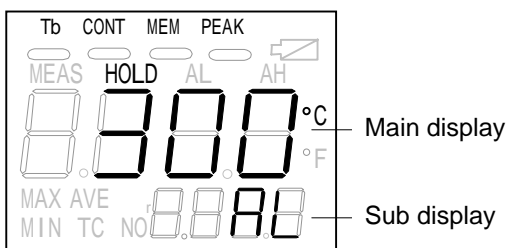

- Program the desired figure by or key and press **ENT** key for shifting the programming digit to the next higher digit.
- Repeat the above procedure up to the most significant digit.
- By pressing **ENT** key at the most significant digit, the programming of low alarm setpoint will be completed.

Reference

- The programming range is "oFF" or the followings.
300 to 1000°C/572 to 1832°F (IR-HI), 600 to 2000°C/1112 to 3632°F (IR-HS)
400 to 3000°C/752 to 5432°F (IR-HQH)
- The default is "oFF".

5. Measuring

*Make sure to press any keys until you hear an audible beep.

Reference

[How to reprogram the low alarm set-point to "oFF"]

- Press **SEL** key for about 2 seconds to display "AL" on the sub display.
- By programming the set-point to be lower than the lower limit value shown in the above by , and **ENT** keys, "oFF" will be displayed.
[Ex. Lower than 299°C (571°F) for IR-HI, lower than 599°C (1111°F) for IR-HS, lower than 399°C (751°F) for IR-HQH]
- Press **ENT** key to store it.

5.7.2 High alarm setpoint programming

This programming is for a judgment of high alarm during measurement.

When the high alarm is judged, the status marker "AH" will light and the buzzer will sound.

When the "oFF" is selected, neither the alarm judgment can be executed nor the buzzer can be sound.

- Press **MEAS** key for about 1 second to turn on the power supply and then release **MEAS** key. The status marker "HOLD" will light.
- Press **SEL** key for about 2 seconds in the hold mode to move to the programming mode. A parameter will be displayed in the main display and its item will be displayed in the sub display.
- Press **SEL** key to display "AH" in the sub display.
- By pressing key, the least significant digit will blink for programming it.

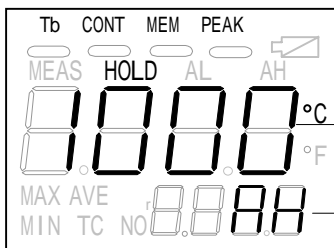

Main display

Sub display

- Program the desired figure by or key and press **ENT** key for shifting the programming digit to the next higher digit.
- Repeat the above procedure up to the most significant digit.
- By pressing **ENT** key at the most significant digit, the programming of high alarm set-point will be completed.

Reference

- The programming range is "oFF" or the followings.
300 to 1000°C/572 to 1832°F (IR-HI), 600 to 2000°C/1112 to 3632°F (IR-HS)
400 to 3000°C/752 to 5432°F (IR-HQH)
- The default is "oFF".

Reference

[How to reprogram the low alarm set-point to "oFF"]

- Press **SEL** key for about 2 seconds to display "AH" on the sub display.
- By programming the set-point to be lower than the lower limit value shown in the above by , and **ENT** keys, "oFF" will be displayed.
[Ex. Lower than 299°C (571°F) for IR-HI, lower than 599°C (1111°F) for IR-HS, lower than 399°C (751°F) for IR-HQH]
- Press **ENT** key to store it.

5.7.3 Modulation ratio selection

When the "dELy" is selected in the signal modulation mode, the first-order lag degree can be adjusted by setting of the modulation time constant.

Further, when the "PEAk" is selected, the damping degree of signal after tracing the peak value can be adjusted.

- Press **MEAS** key for about 1 second to turn on the power supply and then release **MEAS** key. The status marker "HOLD" will light.
- Press **SEL** key for about 2 seconds in the hold mode to move to the programming mode. A parameter will be displayed in the main display and its item will be displayed in the sub display.

5. Measuring

*Make sure to press any keys until you hear an audible beep.

5.7.3-1) Modulation time constant selection (effective when the "dLEy" is selected in the signal modulation mode)

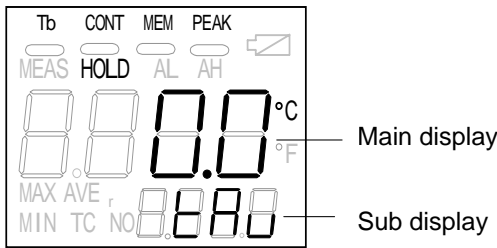

- Press **SEL** key to display "tAu" in the sub display.
- By pressing or key, the modulation time constant will blink in order of 0.0 0.2 0.5 1.0 (second) in the main display. Select the desired modulation time constant and press **ENT** key.

Remarks

- The default is "0.0" second. (The displayed value is based on the real signal without any modulation.)

5.7.3-2) Damping degree selection (effective when the "PEAk" is selected in the signal modulation mode)

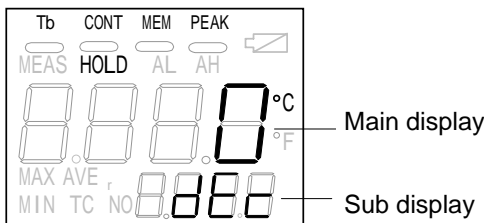

- Press **SEL** key to display "dEc" in the sub display.
- By pressing or key, the modulation time constant will blink in order of 0 2 5 10 (°C/second) in the main display. Select the desired damping degree and press **ENT** key.

5.7.4 Interval time programming

When the automatic data storage mode is selected, program the interval time for storing the measured data.

Reference

- This programming is only effective in the automatic data storage mode. (Ref: [6.2 Automatic data storage mode])

- Press **MEAS** key for about 1 second to turn on the power supply and then release **MEAS** key. The status marker "HOLD" will light.
- Press **SEL** key for about 2 seconds in the hold mode to move to the programming mode. A parameter will be displayed in the main display and its item will be displayed in the sub display.
- Press **SEL** key to display "int" in the sub display.
- By pressing or key, the least significant digit will blink for programming it.

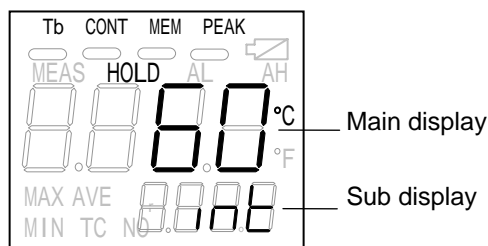

- Program the desired figure by or key and press **ENT** key for shifting the programming digit to the next higher digit.
- Repeat the above procedure up to the most significant digit.
- By pressing **ENT** key at the most significant digit, the programming of interval time will be completed.

Remarks

- The programming range is **1 to 7200** seconds.
- The default is "**60**" seconds.

6. Temperature data storage *Make sure to press any keys until you hear an audible beep.

The thermometer provides a function of storing measured data (temperature measurement by the thermometer, temperature measured by the thermocouple and the emissivity).

The data storage number is from 1 to 500.

Two kinds of the data storage mode, the manual data storage mode for storing the measured data when **ENT** key is pressed and the automatic data storage mode for storing the measured data at the interval time programmed, are available.

6.1 Manual data storage mode

- Press **MEM** key in the hold mode in the standard measurement mode or continuous measurement mode (Ref: [5.1 Standard measurement mode], [5.2 Continuous measurement mode]) to move to the data storage mode. The " — " mark under the main marker **MEM** will light. At the same time, in case that the manual data storage mode is selected in [5.6.2 Data storage mode selection], **mAn** will appear in the main display instantly and **NO** will be displayed in the sub marker. Also, the data storage number **1** will be displayed in the sub display for the initial data storage. When measured data have been already stored in any data storage number, the **"next number"** to the last data storage number will be displayed.

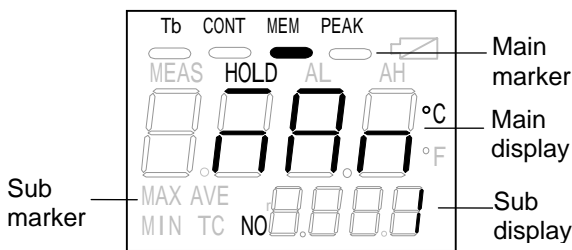

- If **"int"** (automatic data storage mode) is appeared in the main display instantly, change the data storage mode to the manual data storage mode **"mAn"**. (Ref: [5.6.2 Data storage mode selection]).
(Note) **"mAn"** will appear **instantly** when **MEM** key is pressed.

Reference

- After then, **"non"** will be displayed in the main display for the initial data storage.
- Also, **"non"** will be displayed when the next number to the last data storage number is displayed.

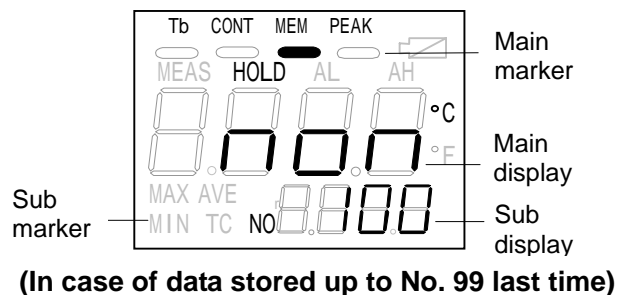
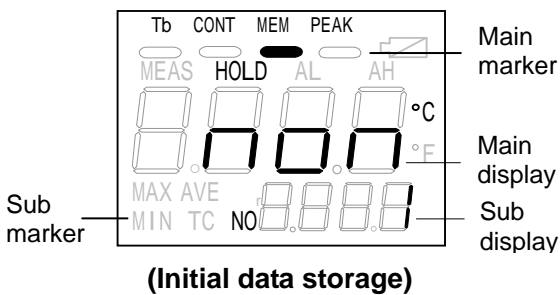

Reference

- In case that the measured data have been stored in the data storage mode last time, the next number to the last data storage number will be displayed in the sub display. (For the above example, the number "100" will be displayed when the measured data have been stored up to the number 99.)

- Press **MEAS** key for about 1 second to measure. The measurement is depended on the measurement mode (Ref: [5.1 Standard measurement mode], [5.2 Continuous measurement mode]).

6. Temperature data storage *Make sure to press any keys until you hear an audible beep.

Reference

- Data storage in the standard measurement mode : In the measurement by keeping **MEAS** key pressed (with the status marker "MEAS" lit) or in the temporary measurement stop (with the status marker "HOLD" lit), by pressing **ENT** key, the measured data (thermometer temperature, thermocouple temperature and emissivity) will be stored. The sub display will display "Str" instantly when the measured data is stored, and then will display the next data storage number.
- Data storage in the continuous measurement mode : In the measurement by keeping **MEAS** key pressed (on the condition that the " — " mark under the main marker "CONT" and the status marker "MEAS" light together), by pressing **ENT** key, the measured data (thermometer temperature, thermocouple temperature and emissivity) will be stored. The sub display will display "Str" instantly when the measured data is stored, and then will display the next data storage number.

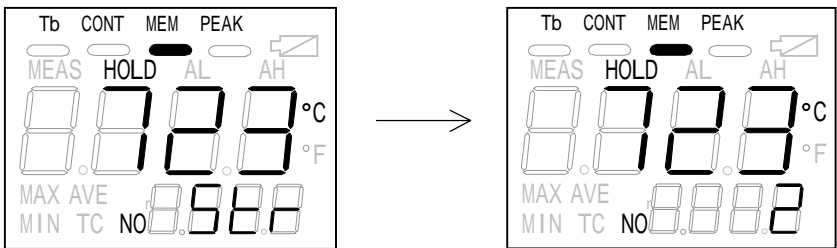

Reference

- On this condition, by pressing **SEL** key, "TC" will be displayed in the sub marker and the thermocouple temperature will be displayed in the sub display. Further, by pressing **SEL** key, " " will be displayed in the sub marker and the emissivity will be displayed in the sub display.
- The emissivity displayed is the emissivity programmed in [5.4 Emissivity programming] or 1.000 (default) if not programmed.

Remarks

- To return to the standard measurement mode or the automatic measurement mode from the data storage mode,
 - for the standard measurement mode, release **MEAS** key to move to the "hold" mode
 - for the continuous measurement mode, press **MEAS** key again to move to the "hold" mode.
 In the hold mode, press **MEM** key. Confirm that the " — " mark under the main marker "MEM" disappears.

Remarks

- For changing the emissivity at the above **Reference**,
 - for the standard measurement mode, release **MEAS** key to move to the "hold" mode
 - for the continuous measurement mode, press **MEAS** key again to move to the "hold" mode.
 Referring to [5.4 Emissivity programming], program a new emissivity by pressing **[]**, **[]** and **ENT** keys in the "hold" mode.
- The new emissivity programmed will be effective from the next data storage number. When you change the emissivity at the specific data storage number, follow this procedure.

6. Temperature data storage *Make sure to press any keys until you hear an audible beep.

Reference

- (1) Initial data storage number: The initial data storage number starts from "1".
- (2) Specific data storage number programming: The specific data storage number for the next data storage is programmable by pressing , and **ENT** keys in the hold mode. (Ref: [6.3.1 Data storage number programming in manual data storage mode])

Reference

- The measured data stored in the specific data storage number can be recalled by [(2) Specific data storage number programming]. (Ref. [6.3.3 Recalling of stored data on manual data storage mode])

Caution

- On the condition that the measured data stored in the specific data storage number is being displayed in the main display, if you press **MEAS** key to measure and then press **ENT** key, be careful that the measured data already stored will be overwritten by a new measured data..
- If you do not want to overwrite, follow the procedures shown in [6.3.1 Data storage number programming in manual data storage mode].

Caution

- Measured data can be stored in the data storage number from No. 1 to No. 500, but when a measured data is stored in the data storage No. 500, the memory becomes in the memory full condition and new measured data can not be stored even if **ENT** key is pressed after then. (Ref: [6.4 Memory full])

6.2 Automatic data storage mode

- Press **MEM** key in the "hold" mode in the standard measurement mode or continuous measurement mode (Ref: [5.1 Standard measurement mode], [5.2 Continuous measurement mode]) to move to the data storage mode. The " — " mark under the main marker "MEM" will light. At the same time, in case that the automatic data storage mode is selected in [5.6.2 Data storage mode selection], "int" will appear in the main display instantly and "NO" will be displayed in the sub marker. Also, the data storage number "1" will be displayed in the sub display for the initial data storage. When measured data have been already stored in any data storage number, the "next number" to the last data storage number will be displayed.

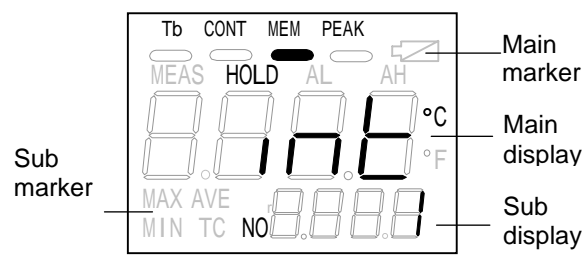

- If "mAn" (manual data storage mode) is appeared in the main display instantly, change the data storage mode to the automatic data storage mode "int". (Ref. [5.6.2 Data storage mode selection]. (Note) "int" will appear **instantly** when **MEM** key is pressed.

Remarks

- After then, "non" will be displayed in the main display for the initial data storage.
- Also, "non" will be displayed when the next number to the last data storage number is displayed.

6. Temperature data storage *Make sure to press any keys until you hear an audible beep.

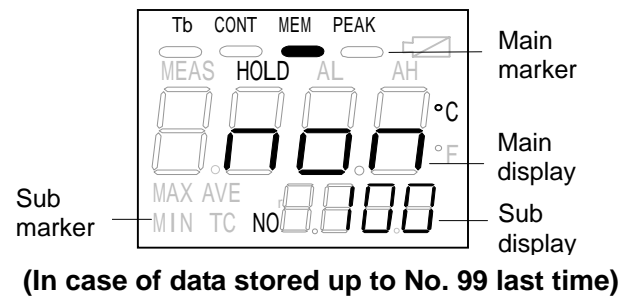
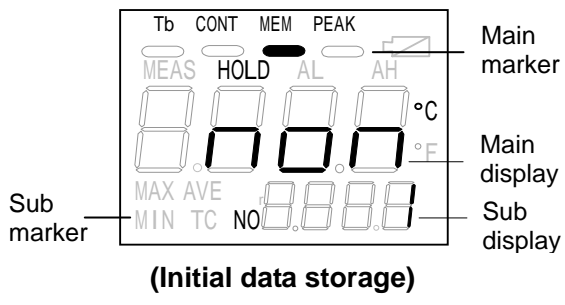

Reference

- In case that the measured data have been stored in the data storage mode last time, the next number to the last data storage number will be displayed in the sub display. (For the above example, the number "100" will be displayed when the measured data have been stored up to the number 99.)

- Press **MEAS** key for about 1 second to measure. The measurement is depended on the measurement mode (Ref: [5.1 Standard measurement mode], [5.2 Continuous measurement mode]).

Reference

- Data storage in the standard measurement mode : In the measurement by keeping **MEAS** key pressed (with the status marker "MEAS" lit), the measured data (thermometer temperature, thermocouple temperature and emissivity) will be stored at the interval time programmed (Ref: [5.7.4 Interval time programming]). The sub display will display "Str" instantly when the data is stored, and then will display the next data storage number.
- Data storage in the continuous measurement mode : In the continuous measurement by pressing **MEAS** key (on the condition that the " — " mark under the main marker "CONT" and the status marker "MEAS" light together), the measured data (thermometer temperature, thermocouple temperature and emissivity) will be stored at the interval time programmed (Ref: [5.7.4 Interval time programming]). The sub display will display "Str" instantly when the data is stored, and then will display the next data storage number.

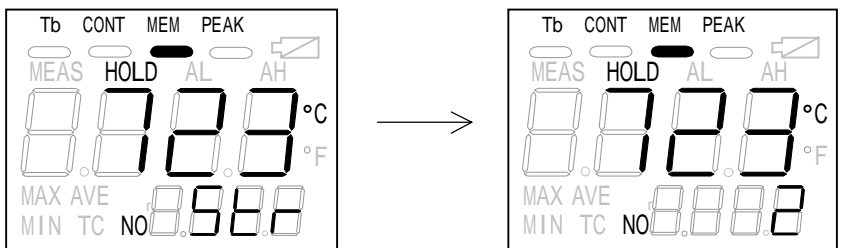

Reference

- On this condition, by pressing **SEL** key, "TC" will be displayed in the sub marker and the thermocouple temperature will be displayed in the sub display. Further, by pressing **SEL** key, " " will be displayed in the sub marker and the emissivity will be displayed in the sub display.
- The emissivity displayed is the emissivity programmed in [5.4 Emissivity programming] or 1.000 (default) if not programmed.

6. Temperature data storage *Make sure to press any keys until you hear an audible beep.

Remarks

- To return to the standard measurement mode or the automatic measurement mode from the data storage mode,
for the standard measurement mode, release **MEAS** key to move to the “hold” mode
for the continuous measurement mode, press **MEAS** key again to move to the “hold” mode.
In the hold mode, press **MEM** key. Confirm that the " — " mark under the main marker "MEM" disappears.

Remarks

- For changing the emissivity at the above **Reference**,
for the standard measurement mode, release **MEAS** key to move to the “hold” mode
for the continuous measurement mode, press **MEAS** key again to move to the “hold” mode.
Referring to [5.4 Emissivity programming], program a new emissivity by pressing **□** , **□** and **ENT** keys in the hold mode.
- The new emissivity programmed will be effective from the next data storage number.
When you change the emissivity at the specific data storage number, follow this procedure.

Reference

- (1) Initial data storage number: The initial data storage number starts from "1".
- (2) Specific data storage number programming: The specific data storage number for the next data storage is programmable by pressing **□** , **□** and **ENT** keys in the hold mode. (Ref: [6.3.2 Data storage number programming in automatic data storage mode])

Reference

- The measured data stored in the specific data storage number can be recalled by [(2) Specific data storage number programming]. (Ref: [6.3.4 Recalling of stored data on automatic data storage mode])

Caution

- On the condition that the measured data stored in the specific data storage number is being displayed in the main display, if you press **MEAS** key to measure and then press **ENT** key, be careful that the measured data already stored will be overwritten by a new measured data..
- If you do not want to overwrite, follow the procedures shown in [6.3.2 Data storage number programming in automatic data storage mode].

Caution

- Measured data can be stored in the data storage number from No. 1 to No. 500, but when a measured data is stored in the data storage No. 500, the memory becomes in the memory full condition and new measured data can not be stored even if **ENT** key is pressed after then. (Ref: [6.4 Memory full])

6. Temperature data storage *Make sure to press any keys until you hear an audible beep.

6.3 Data storage number programming and recalling of stored data

6.3.1 Data storage number programming in manual data storage mode

(Select "mAn" in [5.6.2 Data storage mode selection].)

For programming a data storage number for the next data storage, take the following procedure.

- Press **MEM** key in the "hold" mode in the standard measurement mode or continuous measurement mode to move to the data storage mode. The "—" mark under the main marker "MEM" will light. At the same time, in case that the manual data storage mode is selected in [5.6.2 Data storage mode selection], "mAn" will appear in the main display instantly and "NO" will be displayed in the sub marker. Also, the data storage number "1" will be displayed in the sub display for the initial data storage. When measured data have been already stored in any data storage number, the "next number" to the last data storage number will be displayed.

Reference

- After then, "non" will be displayed in the main display for the initial data storage.
- Also, "non" will be displayed when the next number to the last data storage number is displayed.

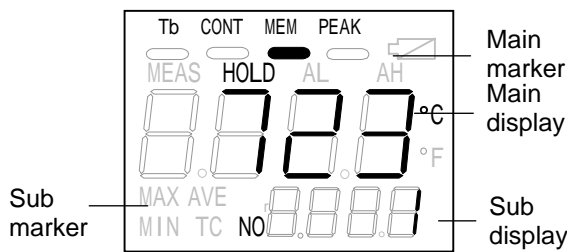

- By pressing or key in the hold mode, the least significant digit will blink for programming it.
- Program the desired figure by or key and press **ENT** key for shifting the programming digit to the next higher digit.
- Repeat the above procedure up to the most significant digit.
- By pressing **ENT** key at the most significant digit, the programming of data storage number will be completed.

Reference

- When any measured data has not been stored in the data storage number programmed, "non" will be displayed in the main display.

Reference

- When a measured data has been stored in the data storage number programmed, its temperature data will be displayed in the main display.

Caution

- On condition that a data storage number has been programmed by the above procedure, when you press **MEAS** key to start a measurement and then press **ENT** key, the measured data already stored in its data storage number will be overwritten by a new measured data.
- If you do not want to overwrite the measured data already stored in its data storage number, follow the above procedure again to select the data storage number that any measured data has not been stored in.

6. Temperature data storage *Make sure to press any keys until you hear an audible beep.

6.3.2 Data storage number programming in automatic data storage mode

(Select "int" in [5.6.2 Data storage mode selection].)

For programming a data storage number for the next data storage, take the following procedure.

- Press **MEM** key in the hold mode in the standard measurement mode or continuous measurement mode to move to the data storage mode. The "—" mark under the main marker "MEM" will light. At the same time, in case that the automatic data storage mode is selected in [5.6.2 Data storage mode selection], "int" will appear in the main display instantly and "NO" will be displayed in the sub marker. Also, the data storage number "1" will be displayed in the sub display for the initial data storage. When measured data have been already stored in any data storage number, the "next number" to the last data storage number will be displayed.

Reference

- After then, "non" will be displayed in the main display for the initial data storage.
- Also, "non" will be displayed when the next number to the last data storage number is displayed.

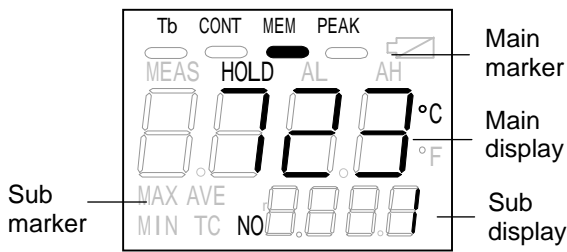

- By pressing or key in the hold mode, the least significant digit will blink for programming it.
- Program the desired figure by or key and press **ENT** key for shifting the programming digit to the next higher digit.
- Repeat the above procedure up to the most significant digit.
- By pressing **ENT** key at the most significant digit, the programming of data storage number will be completed.

Reference

- When any measured data has not been stored in the data storage number programmed, "non" will be displayed in the main display.

Reference

- When a measured data has been stored in the data storage number programmed, its temperature data will be displayed in the main display.

Caution

- On condition that a data storage number has been programmed by the above procedure, when you press **MEAS** key to start a measurement, measured data already stored in its data storage number and after will be overwritten by new measured data.
- If you do not want to overwrite measured data already stored in its data storage number and after, follow the above procedure again to select the data storage number that any measured data has not been stored in.

6. Temperature data storage *Make sure to press any keys until you hear an audible beep.

6.3.3 Recalling of stored data on manual data storage mode

(Select "mAn" in [5.6.2 Data storage mode selection].)

For programming a data storage number for the next data storage, take the following procedure.

- Press **MEM** key in the hold mode in the standard measurement mode or continuous measurement mode to move to the data storage mode. The " — " mark under the main marker "MEM" will light. At the same time, in case that the manual data storage mode is selected in [5.6.2 Data storage mode selection], "mAn" will appear in the main display instantly and "NO" will be displayed in the sub marker. Also, the data storage number "1" will be displayed in the sub display for the initial data storage. When measured data have been already stored in any data storage number, the "next number" to the last data storage number will be displayed.

Reference

- After then, "non" will be displayed in the main display for the initial data storage.
- Also, "non" will be displayed when the next number to the last data storage number is displayed.

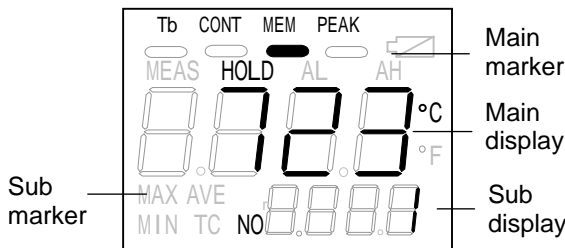

- By pressing or key in the hold mode, the least significant digit will blink for programming it.
- Program the desired figure by or key and press **ENT** key for shifting the programming digit to the next higher digit.
- Repeat the above procedure up to the most significant digit.
- By pressing **ENT** key at the most significant digit, the programming of data storage number to recall will be completed.

Reference

- The temperature data stored in the data storage number recalled will be displayed in the main display.

Remarks

- On this condition, by pressing **SEL** key, "TC" will displayed in the sub marker and the thermocouple temperature, that has been stored together with the temperature data in the main display, will be displayed in the sub display.
- Further, press **SEL** key to display " " in the sub marker. The emissivity, which has been stored together with the temperature data in the main display, will be displayed in the sub display.

Reference

- When any measured data has not been stored in the data storage number recalled, "non" will be displayed in the main display.

6. Temperature data storage *Make sure to press any keys until you hear an audible beep.

Caution

When you recall a stored data, be careful on the following point.

(Example)

- 1) If the measured data have been stored in the data storage number up to No. 100, "101", that is the next number to the last data storage number, will be displayed in the sub display.
- 2) At this time, if you want to display the measured data stored in the data storage No. 98, recall the number "98" by , and **ENT** keys following the above procedure, to display the measured data stored.
- 3) On this condition, if **MEAS** key is pressed again to measure and then **ENT** key is pressed, a new measured data will be stored in the data storage No. 98 and then the data storage number becomes No. 99. It means the measured data already stored in No.98 will be overwritten by a new measured data.

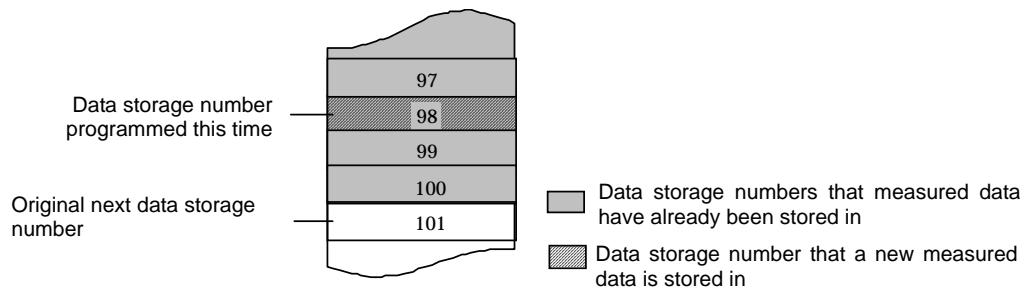

If you do not want to overwrite the measured data already stored, re-program the data storage number to be the next number that a new measured data is to be stored originally. (Refer to [6.3.1 Data storage number programming on manual data storage mode] for re-programming.)

Reference

- For canceling the display of the data stored, press **MEAS** key to disappear the " — " mark under the main marker "MEM".
- For starting the measurement again, refer to [5.1 Standard measurement mode] and [5.2 Continuous measurement mode].

6. Temperature data storage *Make sure to press any keys until you hear an audible beep.

6.3.4 Recalling of stored data on manual data storage mode

(Select "int" in [5.6.2 Data storage mode selection].)

For programming a data storage number for the next data storage, take the following procedure.

- Press **MEM** key in the hold mode in the standard measurement mode or continuous measurement mode to move to the data storage mode. The "—" mark under the main marker "MEM" will light. At the same time, in case that the manual data storage mode is selected in [5.6.2 Data storage mode selection], "int" will appear in the main display instantly and "NO" will be displayed in the sub marker. Also, the data storage number "1" will be displayed in the sub display for the initial data storage. When measured data have been already stored in any data storage number, the "next number" to the last data storage number will be displayed.

Reference

- After then, "non" will be displayed in the main display for the initial data storage.
- Also, "non" will be displayed when the next number to the last data storage number is displayed.

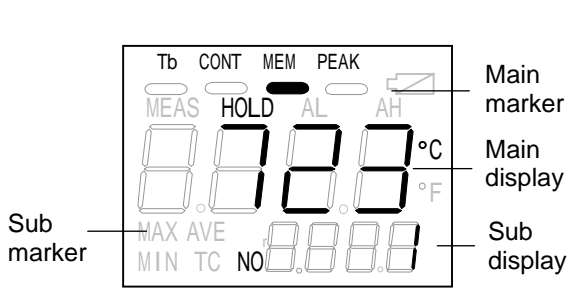

- By pressing **MEM** or **MEM** key in the hold mode, the least significant digit will blink for programming it.
- Program the desired figure by **MEM** or **MEM** key and press **ENT** key for shifting the programming digit to the next higher digit.
- Repeat the above procedure up to the most significant digit.
- By pressing **ENT** key at the most significant digit, the programming of data storage number to recall will be completed.

Reference

- The temperature data stored in the data storage number recalled will be displayed in the main display.

Remarks

- On this condition, by pressing **SEL** key, "TC" will displayed in the sub marker and the thermocouple temperature, that has been stored together with the temperature data in the main display, will be displayed in the sub display.
- Further, press **SEL** key to display " " in the sub marker. The emissivity, which has been stored together with the temperature data in the main display, will be displayed in the sub display.

Reference

- When any measured data has not been stored in the data storage number recalled, "non" will be displayed in the main display.

6. Temperature data storage *Make sure to press any keys until you hear an audible beep.

Caution

When you recall a stored data, be careful on the following point.

(Example)

- 1) If the measured data have been stored in the data storage number up to No. 100, "101", that is the next number to the last data storage number, will be displayed in the sub display.
- 2) At this time, if you want to display the measured data stored in the data storage No. 98, recall the number "98" by , and **ENT** keys following the above procedure, to display the measured data stored.
- 3) On this condition, if **MEAS** key is pressed again to measure, new measured data will be stored from the data storage No. 98. It means the measured data already stored from No.98 will be overwritten by new measured data.

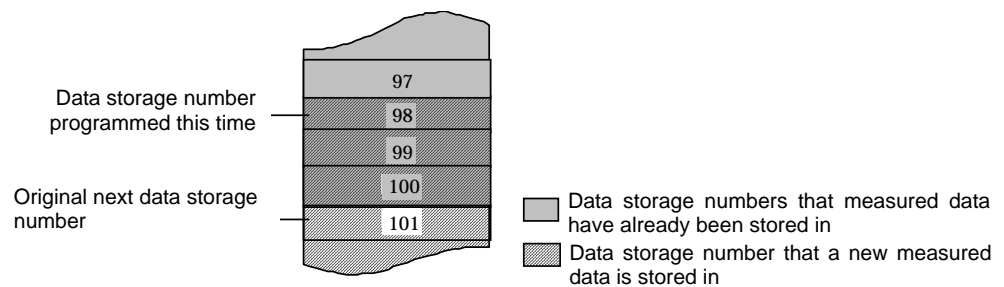

If you do not want to overwrite the measured data already stored, re-program the data storage number to be the next number that a new measured data is to be stored originally. (Refer to [6.3.1 Data storage number programming on manual data storage mode] for re-programming.)

Reference

- For canceling the display of the data stored, press **MEAS** key to disappear the " — " mark under the main marker "MEM".
- For starting the measurement again, refer to [5.1 Standard measurement mode] and [5.2 Continuous measurement mode].

6. Temperature data storage *Make sure to press any keys until you hear an audible beep.

6.4 Memory full

The data storage number is up to No. 500. When a measured data is stored in the data storage No. 500, the memory becomes full and new measured data can not be stored after then.

Remarks

- On the memory full condition, the " — " mark under the main marker "MEM" will blink.

In case that the measured data is stored in the data storage No. 500,

<Data storage in the manual measurement mode>

- In the measurement mode or the hold mode, by pressing **ENT** key, the measured data (thermometer temperature, thermocouple temperature and emissivity) will be stored in the data storage No. 500.
- The sub display will display "Str" instantly when the measured data is stored, and the memory becomes full.
- The sub display will display No. **500** and the main marker "HOLD" lights continuously. Further the " — " mark under the main marker "MEM" will blink continuously. After then, any measured data can not be stored.

On this condition, if **ENT** key is pressed for storing a new measured data, the sub display will display "FULL" instantly and then display No. **500**.

<Data storage in the continuous measurement mode>

- In the measurement mode (with the status marker "MEAS" lit), the measured data (thermometer temperature, thermocouple temperature and emissivity) will be stored at the interval time programmed.
- The sub display will display "Str" instantly every time when the measured data is stored. After the measured data is stored in the data storage No. 500, the memory becomes full. Further the " — ' mark under the main marker "MEM" will blink continuously. After then, any measured data can not be stored.

On this condition, if **ENT** key is pressed for storing a new measured data, the sub display will display "FULL" instantly and then display No. **500**.

Reference

- For storing a new measured data on the above condition,
 - 1) Store the new measured data in the data storage number, that have not stored any measured data, by referring to [6.3.1 Data storage number programming in manual data storage mode], [6.3.2 Data storage number programming on automatic data storage mode], or
 - 2) Store the new measured data in the data storage number, that can be overwritten, by referring to [6.3.1 Data storage number programming in manual data storage mode], [6.3.2 Data storage number programming on automatic data storage mode], or
 - 3) Store the new measured data by erasing the measured data stored, by referring to [6.8 Erasing all stored data].

6. Temperature data storage *Make sure to press any keys until you hear an audible beep.

6.5 Erasing all stored data

When all data being stored are not necessary or the memory becomes full (Ref: [6.4 Memory full], take the following procedure to erase all stored data.

- Press **MEM** key in the hold mode on the standard or continuous measurement mode to move to the data storage mode. The " — " mark under the main marker "MEM" will light. (The " — " mark will blink on the memory full condition).
- By pressing **SEL** key for about 2 seconds in the hold mode, a parameter will be displayed in the main display and its item will be displayed in the sub display.
- Press **SEL** key to display "AdEL" in the sub display.

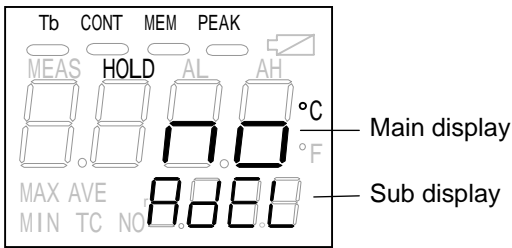

- At the first time, "no" (deletion disable) will be displayed in the main display.
- By pressing or key, either "no" (deletion disable) or "yES" (deletion enable) will blink in the main display.

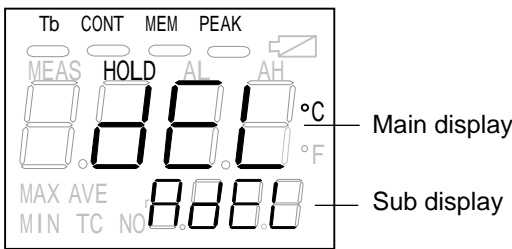

- For the deletion of all data stored, select "yES" (deletion enable) and then press **ENT** key. "dEL" will be displayed instantly and then "no" will light in the main display. If no data have been stored, "non" will be displayed instantly and then "no" will light in the main display.
- If you do not want to delete all data stored, select "no" (deletion disable) and then press **ENT** key. The blinking of "no" will stop and "no" will light.

- To quit this mode, press **SEL** key for about 2 seconds.

Remarks • The default is "no" (deletion disable).

7. User calibration *Make sure to press any keys until you hear an audible beep.

For the routine calibration of the thermometer, the user calibration function is provided to recalibrate the thermometer by using your black body furnace for calibration.

7.1 User calibration procedure • • • (The procedure based on Model IR-HI is discussed.)

By referring to the table [calibration point table], prepare a blackbody furnace covering the zero point temperature and the span point temperature of the Range to be calibrated.

[calibration point table]

Model	Calibration Point	Sub-display	Furnace Temperature	
IR-HI	Range 1	Zero point	AJ 1	310°C / 590°F
		Span point	AJ 2	410°C / 770°F
	Range 2	Zero point	AJ 3	410°C / 770°F
		Span point	AJ 4	660°C / 1220°F
	Range 3	Zero point	AJ 5	660°C / 1220°F
		Span point	AJ 6	990°C / 1814°F
IR-HS	Range 1	Zero point	AJ 1	610°C / 1130°F
		Span point	AJ 2	870°C / 1568°F
	Range 2	Zero point	AJ 3	870°C / 1568°F
		Span point	AJ 4	1300°C / 2372°F
	Range 3	Zero point	AJ 5	1300°C / 2372°F
		Span point	AJ 6	1990°C / 3614°F
IR-HQH	Range 1	Zero point	AJ 1	410°C / 770°F
		Span point	AJ 2	610°C / 1130°F
	Range 2	Zero point	AJ 3	610°C / 1130°F
		Span point	AJ 4	870°C / 1568°F
	Range 3	Zero point	AJ 5	870°C / 1568°F
		Span point	AJ 6	1300°C / 2372°F
	Range 4	Zero point	AJ 7	1300°C / 2372°F
		Span point	AJ 8	1990°C / 3614°F
	Range 5	Zero point	AJ 9	1900°C / 3614°F
		Span point	AJ10	2700°C / 4892°F

Caution

By using a reference radiation thermometer, measure and adjust the furnace temperature to be within ±10°C (°F) of the value (furnace temperature) listed in the [calibration point table] a gone. Make sure to record the temperature measured by the reference radiation thermometer for your calibration procedure.

Reference

In case of the calibration at a specified temperature, you can calibrate by 2 points of temperature including its temperature.
 (Ex) For the calibration of IR-HI at 700°C:
 Prepare a blackbody covering 660°C at the zero point and 990°C at the span point.
 By using a reference radiation thermometer, measure the zero and span points.
 Then adjust the furnace temperature
 to be between 650 and 670°C for the zero point
 to be between 980 and 1000°C for the span point.
 Record the temperatures measured by the reference radiation thermometer.

Range 1		Range 2		Range 3	
Zero point	Span point	Zero point	Span point	Zero point	Span point
AJ 1	AJ 2/AJ 3	AJ 4/AJ 5	AJ 6		
-----	-----	663°C	995°C		

7. User calibration *Make sure to press any keys until you hear an audible beep.

Place your thermometer at the distance of about 1m from the blackbody furnace and fix it on a tripod. Focus the center circle of the targeting mark in the viewfinder to the center of the blackbody furnace.

- 1) To turn on the power supply, press , **ENT** and **MEAS** keys simultaneously and release these keys **quickly before the audible beep sounds**.

The status marker "HOLD" will light with the displays of "AJ 1" in the sub display and the furnace temperature at the zero point of Range 1 "310°C" (the zero point temperature of IR-HI shown in the [calibration point table]) will be displayed in the main display.

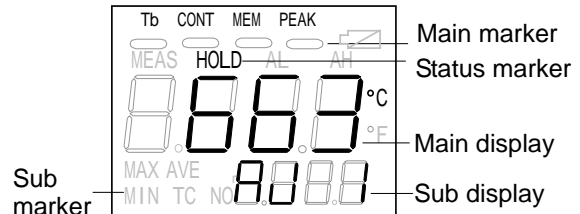
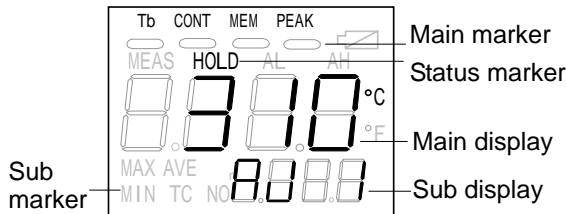

* Display when the releasing timing of , **ENT** and **MEAS** keys is late :

(The status marker "MEAS" will light instantly and then the status marker "HOLD" will light. In the hold mode, the "measured temperature", not the furnace temperature of "AJ 1", will be displayed in the main display.

Repeat the same procedure by referring to **Caution** below.

Caution

- When the releasing timing of , **ENT** and **MEAS** keys is late and the measured temperature is displayed in the main and internal displays, the user calibration can not be executed.

In this case, turn off the power supply once and repeat the above 1) to display "AJ 1" in the sub display and the furnace temperature of "AJ 1" in the main display. (Refer to the above left figure.)

- 2) Press **SEL** key to display "AJ " for the zero point of the Range to be calibrated in the sub display. The furnace temperature of "AJ " shown in the calibration point table will be displayed in the main display.
- 3) If the furnace temperature displayed in the main display equals to the temperature measured by the reference radiation thermometer, step to 4).

If the temperatures are different, set the furnace temperature in the main display to the temperature measured by the reference thermometer by the following procedure.

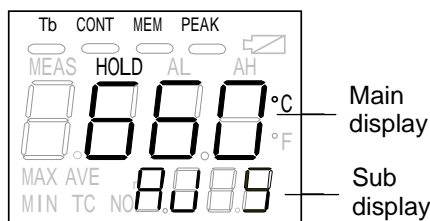

- By pressing key, the least significant digit will blink for programming it.
- Program the desired figure by or key and press **ENT** key for shifting the programming digit to the next higher digit.
- Repeat the above procedure up to the most significant digit.
- By pressing **ENT** key at the most significant digit, the calibration data will be stored.

Remarks

- The programming range is within $\pm 10^{\circ}\text{C}$ ($^{\circ}\text{F}$) of the furnace temperature shown in the [calibration point table] .
- The defaults are the furnace temperatures shown in the [calibration point table] .

7. User calibration

*Make sure to press any keys until you hear an audible beep.

- 4) Press **MEAS** key to measure the temperature of the furnace. (Make sure that the status marker "HOLD" does not light and the status marker "MEAS" lights.)
Release **MEAS** key after the measurement.
Press **ENT** key on the condition that the status marker "MEAS" does not light and the status marker "HOLD" lights.
At this point, the calibration at the zero point is finished.
- 5) Press **SEL** key to display "AJ " for the span point of the Range to be calibrated in the sub display. The furnace temperature of "AJ " shown in the [**calibration point table**] will be displayed in the main display.
- 6) If the furnace temperature displayed in the main display equals to the temperature measured by the reference radiation thermometer, step to 7).
If the temperatures are different, set the main display to the temperature measured by the reference thermometer by the procedure shown in 3).
- 7) As per 4), press **MEAS** key and then press **ENT** key after the measurement.
At this point, the calibration at the span point is finished.
- 8) When you want to calibrate the next range continuously, press **SEL** key to display "AJ " for the zero point of the Range to be calibrated in the sub display.
The furnace temperature of "AJ " shown in the calibration point table will be displayed in the main display or, if the furnace temperature has been already set at the span point of the preceding range, its temperature will be displayed.
- 9) If the furnace temperature displayed in the main display equals to the temperature measured by the reference radiation thermometer or if the furnace temperature has been already set at the span point of the preceding range, step to 10).
If the temperatures are different, set the main display to the temperature measured by the reference thermometer by the procedure shown in 3).
- 10) As per 4), press **MEAS** key and then press **ENT** key after the measurement.
At this point, the calibration at the zero point is finished.
- 11) Calibrate the span point by the procedure 5) to 7).

Reference

- *For the continuous calibration from Range 1 through Range 3, if the furnace temperature at the span point has been set, the setting at the zero point is not necessary.
- For the calibration at the same furnace temperature like as "AJ 2" and "AJ 3", if the furnace temperature is set at the zero point (or the span point), the setting at the span (or the zero point) is not necessary.
Note: When the power supply is turned off during the calibration, the furnace temperature displayed in the main display will return to the default (the furnace temperature shown in the calibration point table).
- For re-calibration, press **SEL** key to display the screen to be re-calibrated and execute the re-calibration of the specific temperature.
- The power supply will be automatically turned off if any key is not pressed for 30 seconds at the hold mode.

Caution

- When the temperature other than the furnace is measured by pressing **MEAS** key and then **ENT** key is pressed, the thermometer is calibrated by its measured temperature. Be careful it.

8. Maintenance and check

8.1 Self-diagnostic function

The thermometer provides the self-diagnostic function.
 The followings are the displays on abnormal conditions.

	Display (Main display)	Contents	Alarm	Countermeasure
Main display (Thermometer)	8888	High limit over range (The object temperature exceeds the measuring range of the thermometer + 20°C.)	The status marker "AH" lights and the buzzer sounds. *1	Is the emissivity programmed too low? Program the correct emissivity by referring to [5.4 Emissivity programming] and [12 Emissivity table].
	8888	Low limit over range (The object temperature is lower than the measuring range of the thermometer - 20°C.)	The status marker "AL" lights and the buzzer sounds. *1	Is the emissivity programmed too high? Program the correct emissivity by referring to [5.4 Emissivity programming] and [12 Emissivity table].
	8888	Abnormal ambient temperature (The thermometer is placed in the environment under 0°C or 50°C)	Er1 display only	Use the thermometer in the environment from 0 to 50°C.
	8888 *2	EEPROM data broken (Stored data, temperature data and calibration data have been initialized by the data ROM broken.)	Er4 display only	Re-adjustment is necessary. Return the thermometer to us. (Stored data and calibration data are initialized.)

	Display (Sub display)	Contents	Alarm	Countermeasure
Sub display (T/C temperature)	8888	High limit over range [The thermocouple is disconnected (broken) or the (object) temperature measured by the thermocouple exceeds 1220°C (2228°F)].	oFL display only	<ul style="list-style-type: none"> If "oFL" is displayed in room temperature, the thermocouple has been broken. Replace it. If "oFL" is displayed in the measurement, the object temperature exceeds 1220°C (2228°F) and the thermocouple may be broken. Stop the measurement by the thermocouple.
	8888	Low limit over range [The (object) temperature measured by the thermocouple is lower than -50°C (-58°F)].	uFL display only	The object temperature exceeds the low limit measuring range of the thermocouple. The thermocouple may be deteriorated. Stop the measurement by the thermocouple.

*1 When the alarm setpoint is "oFF", no buzzer sounds.

*2 When the power supply is turned on or when the stored data is displayed, this error cord is displayed.

8.2 Storage

Caution

- Don't store the thermometer at a hot and/or wet place.
- Make sure to mount the lens cap for storage.
- Remove the batteries if the thermometer is not used for longer than 2 weeks, otherwise the thermometer may become defective due to an electrolyte leak failure of the batteries.

8.3 Cleaning of objective lens

Wipe the objective lens periodically with a soft cloth.

8.4 Cleaning of external display and eyepiece cover

Clean them periodically with a soft cloth.

9. Accessories

9.1 Thermocouple

The thermometer can be used as a surface thermometer by connecting a K type thermocouple (separate purchase required). Connect the thermocouple by inserting its connector to the connector inside the connector cover. (Ref : 3.1.2 [Connector cover inside])

Name	Model	Specification
Thermocouple	C510-01K	K type, Maximum 500°C, Response time about 1.8 seconds, with a ferrite core
Thermocouple for high temperature	C510-02K	K type, Maximum 800°C, Response time about 4 seconds, with a ferrite core

9.2 AC adapter (Model IR-VHRA)

The adapter is for operation of the thermometer with AC power supply.
 For the connection, insert the plug of the adapter into the DC power jack inside the connector cover. (Ref : 3.1.2 [Connector cover inside])

Reference	<ul style="list-style-type: none"> • Specifications: Input voltage 100 to 240V AC, Output voltage 4.8V DC, with a ferrite core
------------------	---

Warning	<ul style="list-style-type: none"> • Make sure that 100 to 240V AC is used for the AC adapter. If not, electrical shock, fire, or damage may be caused. • Do not touch the AC adapter or receptacle with wet hands. • Do not wet the AC adapter. Fire may be caused. • Wipe out dust on the AC adapter. Dust may cause fire.
----------------	--

Caution	<ul style="list-style-type: none"> • Connect the AC adapter to the thermometer with the power supply turned off.
----------------	---

9.3 Tripod (Model IR-ZBMT) and Universal head (Model IR-VMS)

These accessories are used for fixing the thermometer for long-term measurement. Mount the tripod or the universal head by using the mounting screw at the bottom side for them.

9.4 Data Logging Software (IR-VXG1E)

Three kinds of real-time trend mode, multi-point monitoring mode by utilizing the data storage function, and 1-point historical trend mode are available.

Graph display, report creation, printing, and data storage can be easily executed.

The exporting function of the measured data to worksheet applications is also available.

* Windows95/98 is the registered trademarks of Microsoft Corporation, U.S.A.

Reference	<ul style="list-style-type: none"> • This data logging software is for Windows95/98* and the connection cable (RS-232C: D-SUB 9-pin female, with a ferrite core) is attached.
------------------	--

CE	<p>For a thermometer with CE-marking, mount an attached ferrite core to a connection cord at the nearest place to the thermometer.</p>
-----------	--

10. List of Starting Up Modes

10.1 Modes at start up

The following operation modes are available by the key combinations at the start up.

Keys	Modes	Remarks
Press MEAS key only (about 1 second)	Standard measurement or continuous measurement	Measurement with the same measurement mode as the last starting up
Press MEAS while pressing <input type="checkbox"/> key	Standard measurement	
Press MEAS key while pressing <input type="checkbox"/> key	Continuous measurement	The " — " mark will light under the main marker "CONT".
Press MEAS key while pressing ENT and <input type="checkbox"/> keys together	User calibration	On the next starting up with MEAS key only, the measurement will become the standard measurement mode.

10.2 Table of screens

The screens displayed in the external display are the following 3 kinds basically.

Modes	Outline
Measurement mode	Measurement by MEAS key In the hold mode in the standard or continuous measurement mode, the programming and automatic calculation of emissivity is possible.
Data storage mode	Data storage number, stored data display and storing measured data into memory are possible. By pressing MEM key in the standard or continuous measurement mode, the mode will become the data storage mode and the " — " mark will light under the main marker "MEM". For returning to the standard or continuous measurement mode, press MEM key again.
Parameter programming mode	Display and programming of measuring parameters. By pressing SEL key for about 2 seconds in the standard measurement mode, continuous measurement mode or data stage mode, the mode will become the parameter programming mode. In the parameter programming mode, by pressing SEL key for about 2 seconds or any key is not pressed for 1 minute, the mode will return to the measurement mode or the data storage mode.

10. List of Starting Up Modes

10.3 Measuring parameter programming/display

10.3.1 Emissivity programming/display

Parameter item	Display	Parameter	Default	Paragraph
Emissivity (ratio)	ε (εr)	1.900 to 0.100	1.000	5.4

* The emissivity can not be programmed in the data storage mode.

10.3.2 Data storage number programming/display

Parameter item	Display	Parameter	Default	Paragraph
Data storage number	NO	1 to 500	1	6.3

* The data storage number is only displayed in the data storage mode.

10.4 System settings

Parameter item	Sub display	Parameter	Default	Paragraph
Low temperature alarm programming	AL	oFF, 300 to 1000°C/572 to 1832°F (IR-HI) oFF, 600 to 2000°C/1112 to 3632°F (IR-HS) oFF, 400 to 3000°C/752 to 5432°F (IR-HQH)	oFF	5.7.1
High temperature alarm programming	AH	oFF, 300 to 1000°C/572 to 1832°F (IR-HI) oFF, 600 to 2000°C/1112 to 3632°F (IR-HS) oFF, 400 to 3000°C/752 to 5432°F (IR-HQH)	oFF	5.7.2
Signal modulation mode selection	modu	DELY, PEAK	dELY	5.6.1
Modulation ratio selection *1	tAu dEc	0.0, 0.2, 0.5, 1.0 (second) 0, 2, 5, 10°C (°F)/second	0.0s 0°C/s	5.7.3
Data storage mode selection	mmod	mAn, int	mAn	5.6.2
Data storage interval programming	int	1 to 7200 seconds	60s	5.7.4
All stored data erasing	AdEL	no, yES	no	6.5
Communications mode selection	Com	trnS, Com	trnS	5.6.3
Measuring unit selection	Unit	C, F	C	5.6.4
Thermocouple enable/disable selection	TC	oFF, on	oFF	5.6.5
2-color/single color wide selection *2	CoLr	2, 1	2	5.6.6

*1: The parameters of modulation ratio selection are differs by the signal modulation mode.

*2: The 2-color/single color wide selection is displayed in Model IR-HQH only.

(Ref : [5.6.1 Signal modulation mode selection])

11. General Specifications

11.1 Specifications

Type	Single color type for medium temperature	Single color type for high temperature	High functional type (2-color type + single color wide range type)
Model	IR-HI	IR-HS	IR-HQH
Measuring System	Narrow band radiation thermometer		
Detecting Element	InGaAs	Si	Si/InGaAs
Measuring Wavelength	1.55μm	0.9μm	0.9/1.55μm
Measuring Range	300 to 1000°C	600 to 2000°C	600 to 2000°C (2-color) 400 to 3000°C (single color)
Accuracy Ratings	±6°C	Lower than 1000°C: ±6°C 1000°C to 1500°C: ±0.6% of reading Higher than 1500°C: ±1.2% of reading	Lower than 1000°C: ±6°C 1000°C to 1500°C: ±0.6% of reading 1500°C to 2000°C: ±1.2% of reading Higher than 2000°C: ±2.4% of reading
Repeatability	±1°C		
Stability	Temperature drift	Lower than 1000°C: 0.2°C/°C Higher than 1000°C: 0.02%/°C of reading	
	In the test environment required by EMC directives	±3°C ±50°C (at the connection with connection code for RS-232C, AC adapter or thermocouple C510-0 K)	
Resolution	1°C		
Response Time	0.2 second		
Emissivity Compensation	1.900 to 0.100		
Mathematics	Maximum value, minimum value, average value		
Signal Modulation	Peak, delay		
Display System	LCD digital 4 digits, Displayed in the viewfinder and in external display		
Data Memory Function	Maximum 500 data		
Communications Function	RS-232C		
Optical System	Fixed focus type		
Distance/diameter	φ20/4000mm (Ref. 4.2 [Distance and diameter])		
Targeting	Direct viewing finder		
Lens Diameter	φ20mm		
T/C stability	Input/accuracy	K type thermocouple: -50 to 800°C Accuracy: ±2°C (at 23°C ± 5°C)	
	In the test environment required by EMC directives	±10°C	
Other Functions	Auto-power-off, Automatic back-lit display, Continuous measurement, °C/°F selection, Battery check, High / low alarms		
Ambient Temperature	0 to 50°C		
Power Supply	2 AA (UM-3) alkaline batteries (about 50 hours for continuous measurement) or AC adapter (separate purchase required)		
Casing Material and Color	ABS resin, Gray		
Weight	About 350g (thermometer only)		
Attachment	4 pieces of AA (UM-3) battery		

* At =1.0. reference operating conditions: 23°C ± 5°C, relative humidity: 35 to 75%RH

11.2 Outside dimensions

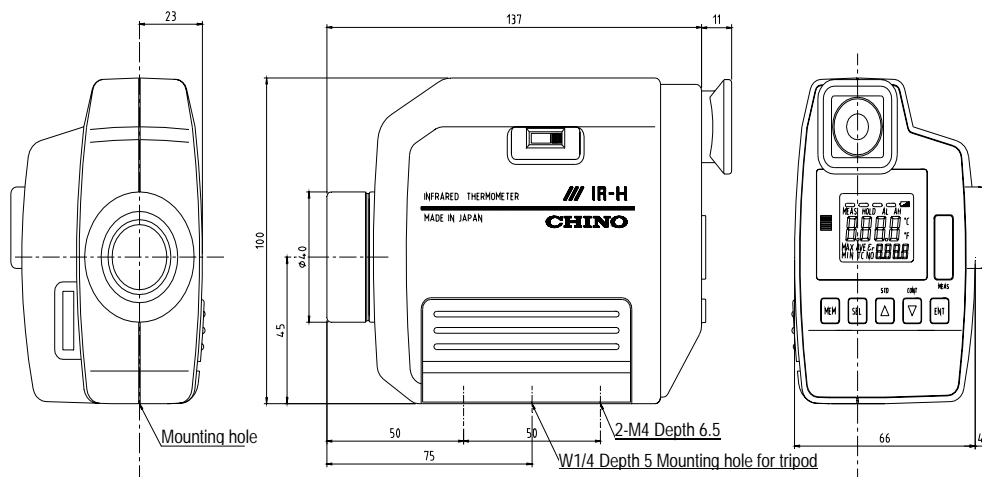

12. Emissivity table

The emissivity are values determined by the material of object, profile of its surface, surface roughness, oxidized or not, measuring temperature, measuring wavelength and other factors. They are represented by the thermal radiation ratio " " when a black body furnace at the same temperature is measured in the same wavelength band.

The emissivity " " is generally known by a value at the wavelength of $0.65\mu\text{m}$ when an optical pyrometer is used. The emissivity changes according to the above factors even in case of the same material. Please use the following table as a reference.

12.1 Emissivity table

12.1.1 Emissivity table ($\lambda = 0.65\mu\text{m}$)

Metal	Emissivity		Oxide	Emissivity
	Solid	Liquid		
Zinc	0.42		Alumel (*)	0.87
Alumel	0.37		Chromel(*)	0.87
Aluminum	0.17	0.12	Constantan (*)	0.84
Antimony	0.32		Ceramics	0.25 to 0.5
Iridium	0.30		Cast iron (*)	0.70
Yttrium	0.35	0.35	55Fe. 37.5Cr. 7.5Al (*)	0.78
Uranium	0.54	0.34	70Fe. 23Cr. 5Al. 2Co (*)	0.75
Gold	0.14	0.22	80Ni. 20Cr (*)	0.90
Silver	0.07	0.07	60Ni. 24Fe. 16Cr (*)	0.83
Chromium	0.34	0.39	Stainless steel (*)	0.85
Chromel P	0.35		Aluminum oxide	0.22 to 0.4
Cobalt	0.36	0.37	Yttrium oxide	0.60
Constantan	0.35		Uranium oxide	0.30
Zirconium	0.32	0.30	Cobalt oxide	0.75
Mercury		0.23	Columbium oxide	0.55 to 0.71
Tin	0.18		Zirconium oxide	0.18 to 0.43
Carbon	0.8 to 0.9		Tin oxide	0.32 to 0.60
Tungsten	0.43		Cerium oxide	0.58 to 0.82
Tantalum	0.49		Titanium oxide	0.50
Cast iron	0.37	0.40	Iron oxide	0.63 to 0.98
Titanium	0.63	0.65	Copper oxide	0.60 to 0.80
Iron	0.35	0.37	Thorium oxide	0.20 to 0.57
Copper	0.10	0.15	Vanadium oxide	0.70
Thorium	0.54	0.34	Beryllium oxide	0.07 to 0.37
Nickel	0.36	0.37	Magnesium oxide	0.10 to 0.43
80Ni /20Cr	0.35			
60Ni / 024Fe / 16Cr	0.36		(*) : Oxidized on surfaces	
Platinum	0.30	0.38		
90Pt / 10Rh	0.27			
Palladium	0.33	0.38		
Vanadium	0.35	0.35		
Bismuth	0.29			
Beryllium	0.61	0.61		
Manganese	0.59	0.59		
Molybdenum	0.37	0.40		
Rhodium	0.24	0.30		

12. Emissivity table

12.1.2 Emissivity table ($\lambda = 0.9\mu\text{m}$)

Metal	Emissivity
Aluminum	0.10 to 0.23
Gold	0.015 to 0.02
Chrome	0.36
Cobalt	0.28 to 0.30
Iron	0.33 to 0.36
Copper	0.03 to 0.06
Tungsten	0.38 to 0.42
Titanium	0.50 to 0.62
Nickel	0.26 to 0.35
Platinum	0.25 to 0.30
Molybdenum	0.28 to 0.36

Alloy	Emissivity
Inconel X	0.40 to 0.60
Inconel 600	0.28
Inconel 617	0.29
Inconel	0.85 to 0.93
Incoloy 800	0.29
Kanthal	0.80 to 0.90
Stainless steel	0.30
Hastelloy X	0.3

Semi conductor	Emissivity
Silicon	0.69 to 0.71
Germanium	0.60
Gallium arsenic	0.68

Ceramics	Emissivity
Silicon carbide	0.80 to 0.83
Titanium carbide	0.47 to 0.50
Silicon nitride	0.89 to 0.90

Other	Emissivity
Carbon pigment	0.90 to 0.95
Graphite	0.87 to 0.92

12.1.3 Emissivity table ($\lambda = 1.55\mu\text{m}$)

Metal	Emissivity
Aluminum	0.09 to 0.40
Chrome	0.34 to 0.80
Cobalt	0.28 to 0.65
Copper	0.05 to 0.80
Gold	0.02
Steel plate	0.30 to 0.85
Lead	0.28 to 0.65
Magnesium	0.24 to 0.75
Molybdenum	0.25 to 0.80
Nickel	0.25 to 0.85
Palladium	0.23
Platinum	0.22
Rhodium	0.18
Silver	0.04 to 0.10
Tantalum	0.20 to 0.80
Tin	0.28 to 0.60
Titanium	0.50 to 0.80
Tungsten	0.30
Zinc	0.32 to 0.55

Alloy	Emissivity
Brass	0.18 to 0.70
Chromel, Alumel	0.30 to 0.80
Constantan, Manganin	0.22 to 0.60
Inconel	0.30 to 0.85
Monel	0.22 to 0.70
Nickel Chrome	0.28 to 0.85

Ceramics	Emissivity
Alumina ceramics	0.30
Red brick	0.80
White brick	0.35
Silicon brick	0.60
Sillimanite brick	0.60
Ceramics	0.50

Other	Emissivity
Asbestos	0.90
Asphalt	0.85
Carbon	0.85
Graphite	0.80
Soot	0.95
Cement, Concrete	0.70
Cloth	0.80

CHINO

CHINO CORPORATION

32-8, KUMANO-CHO, ITABASHI-KU, TOKYO 173-8632

Telephone: +81-3-3956-2171

Facsimile: +81-3-3956-0915

Web site <http://www.chino.co.jp/>

