

IR-AH Series

PORTABLE DIGITAL RADIATION THERMOMETER

Model : IR-AHS ,IR-AHU ,IR-AHT

INSTRUCTIONS

Always keep these instruction with the unit.

Please be sure to deliver these instructions with the unit to the end user.

CONTENTS

1. Introduction	1	8. Analog Output	18
1.1 General	1	8.1 Programming scale	18
1.2 Configuration	1	8.2 Connections	18
2. Model and accessories	1	8.3 Temperature data on analog output	18
2.1 Model	1	9. Maintenance and check	19
2.2 Accessories	1	9.1 Self-diagnostic function	19
3. Names and functions of component parts	2	9.1.1 Low battery	19
4. Preparation for measurement	5	9.1.2 Abnormal internal temperature	19
4.1 Loading batteries	5	9.1.3 EEPROM error	19
4.2 Start and stop	7	9.1.4 Status display	19
4.2.1 Start	7	9.2 Storage	20
4.2.2 Stop	7	9.3 Cleaning of cover glass	20
4.3 Programming temperature unit	7	9.4 Cleaning of external display and eyepiece cover	20
5. Measuring	8	9.5 Initializing of default condition	20
5.1 Measuring procedure	8	10. Accessories	21
5.2 Continuous measurement	8	10.1 Close-up lens	21
5.3 Auto power off	8	10.2 AC adapter	22
5.4 Cautions on measurement	9	10.3 Tripod and Universal head	22
5.5 Measuring	10	10.4 Data Logging Software	22
5.5.1 Programming emissivity	10	11. List of starting Models/Screens	23
5.5.2 Programming signal modulation mode	10	11.1 Models at start time	23
5.5.3 Programming modulation time constant	11	11.2 Table of screens	23
5.5.4 Programming alarms	11	11.2.1 Measuring parameters programming /display items	23
6. Temperature data storage	12	11.2.2 Temperature data storage programming /display items	23
6.1 Manual storage mode	12	11.2.3 Status display items	24
6.2 Storage-with-interval mode	13	11.2.4 System programming display items	24
6.3 Display of data stored	14	12. General specifications	24
6.4 Number of temperature data stored	14	12.1 External dimensions	24
6.5 Deletion of last storage data	14	12.2 Specifications	25
6.6 Deletion of all storage data	15	13. Emissivity table	26
7. User calibration	16	13.1 Emissivity table (= 0.65 μ m)	26
7.1 Calibration method	16	13.2 Emissivity table (= 0.9 μ m)	27
7.2 Recovery of calibration data	17	13.3 Emissivity table (= 1.55 μ m)	27

Caution

Read the items marked with  in the title without fail.

These paragraphs comprise  item.

Request and notices

Please read this instruction manual for using the thermometer correctly and safely.

Request to the operator of the thermometer

This instruction manual describes the maintenance of the thermometer, too.

Keep this instruction manual with the thermometer.

If you have unclear points or need technical assistance, please contact CHINO' s sales agent.

Notices

1. The contents of this instruction manual are subject to change without notice.
2. If any question arises, or if any error, an omission, or other deficiency is found, please inform of it to CHINO' s sales agent.
3. We, CHINO, are not responsible to any operation results.

Preface

To use the thermometer correctly and safely, please keep the following safety measures for the operation and storage of the thermometer.

1 Working conditions and environment

The thermometer is designed as a handheld type. Use a tripod or a simple type universal head for long term or fixed mounting measurement.

The working temperature range of the thermometer is 0 to 50 °C. (No dew condensation)

Do not use the thermometer in dusty places, etc. Remove the dust after using it.

(As for the cleaning of cover glass, refer to the clause of "9.3 Cleaning of cover glass".)

Be careful not to give vibration or impact to the thermometer.

For preventing the consumption of the batteries, turn the **Power Supply Switch** of the thermometer off when it is not used.

As a glass can not transmit the infrared ray in the measuring wavelength of the thermometer, when the thermometer measures an object through the glass, the surface temperature of the glass is measured.

(For Model IR-AHT only)

When the ambient temperature changes rapidly, the measured value may be influenced. When the thermometer has been brought to a place where the ambient temperature is greatly different from the former place, leave the thermometer for one hour and then start the measurement. (For Model IR-AHT only)

2 Storage

Do not store the thermometer in hot and humid places. Make sure to store the thermometer with the lens cap. Recommend to stores the thermometer in room temperature with a dry pill.



Do not leave the thermometer in extreme high ambient temperature such as beside a rear window or inside of a trunk of cars. The thermometer may have troubles.

When the thermometer is not used for 2 weeks or more, take out the batteries from it. Otherwise, the thermometer may be damaged by liquid leakage of the batteries.

When the thermometer has any trouble, please contact to CHINO' s sales agent.

3 Symbol in this instruction manual

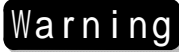

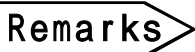
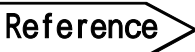



The symbols shown below are used depending on important degrees for using the thermometer safely and avoiding unexpected situations.









Important degree	Symbols	Contents
1		This symbol is attached to a title for the sentence with the Warning
2		For avoiding dangerous accidents (may cause death or serious injury) like as electrical shock, fires, or troubles/damages of the thermometer
3		For avoiding injury or in physical damage to the thermometer.
4		For items that you should know as a supplement for this instruction manual
5		For items that are convenient as a supplement for this instruction manual

Warnings and Cautions

Please use the thermometer correctly by keeping the following items.

In addition, please read this instruction manual carefully and keep it at the place where you can access easily.

	Warning (May cause death or serious injury)
	Make sure not see the sun through the finder of the thermometer. It may cause becoming blind. Never directly face the objective lens to the sun to protect the detecting element. For the measurement of high temperature objects, refer to the clause of "5.4 Cautions on measurement".
	Never operate the thermometer in places where combustible or volatile gas is existed. It is extremely dangerous to use the thermometer in such environment.
	Never put the batteries into fire, or never charge, short-circuit, heat or disassembly the batteries. Breaking or heating of the batteries may cause fire or injury.
	For the AC adapter (IR-VHRA), make sure to use 100 V AC. Other voltage may cause electrical shock, fire or trouble. Never touch the AC adapter or receptacle by wet hands. Never wet the AC adapter for avoiding fire. Wipe the dust on the AC adapter for avoiding fire.
	Never use the thermometer if it has been broken, smoking or nasty smelling. These may cause fire. When the thermometer is broken, smoking, or nasty smelling, turn the power supply switch off at once and take out the batteries, and contact to CHINO' s sales agent.

	Caution (May cause injury or physical damage)
	Do not use other batteries than the batteries specified. Load the batteries so that their polarities meet the polarity marks on the battery case. Different polarities may cause fire, injury or damage by burst or liquid leakage of the batteries.
	Do not walk while sighting through the finder of the thermometer. It may cause accidents like as fall.
	Set the beam attenuation filter selection knob to the beam attenuation side in advance (in case of Model IR-AHS on IR-AHU) for protecting your eyes on the measurement of object exceeding 1500 °C. [Refer to 5.4 Cautions on measurement]
	Never take the thermometer apart or convert it. These may cause trouble and danger.
	Keep the [items] and handling methods described in this instruction manual. When the thermometer is used without keeping them, the thermometer may be damaged or not be functioned perfectly, or may damage other equipment.
	Dispose the batteries used to places specified with the disposal procedure specified.
	This thermometer is not of dustproof structure and is not drop of water proof structure. Never operate the thermometer in places where dust, noise or static electric is existed.

1. Introduction

1.1 General

IR-AH series handheld radiation thermometers can easily measure temperature without any contact over a wide range from -50°C to 3000°C. The thermometers can store the temperature data measured into memory up to maximum 1000 data.

The analysis of the temperature data can be executed easily by combining IR-AH Data Logging Software (sold separately) with this memory function.

1.2 Configuration

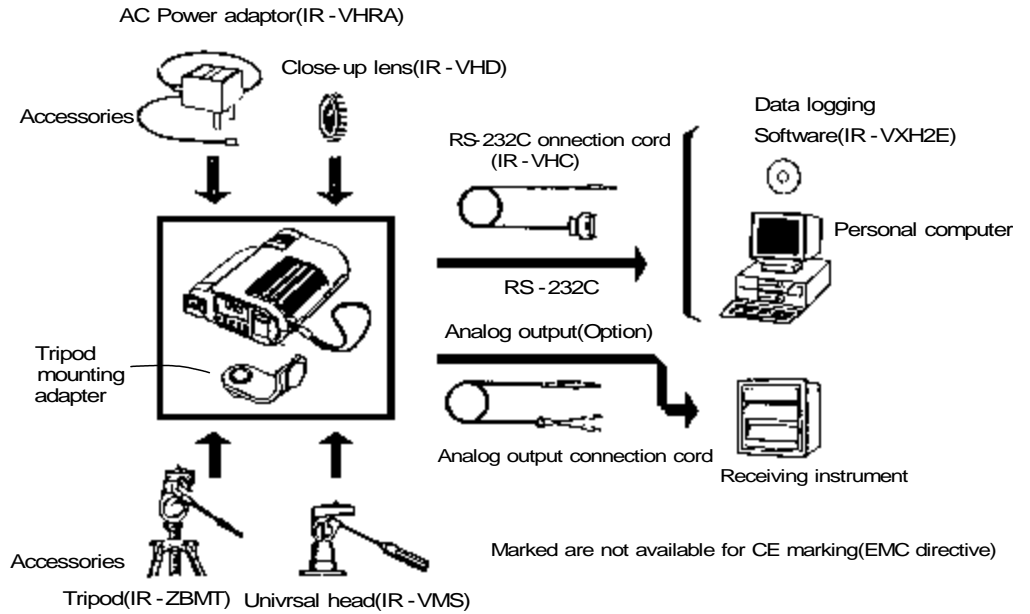

2. Model and accessories

2.1 Model

IR-AH

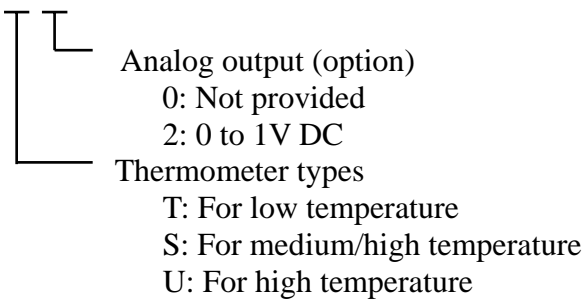

2.2 Accessories

Names	Quantity	Remarks
AA (UM-3) battery	4	
Tripod mounting adapter	1	
Instruction manual	1	This manual
Housing case	1	

CE- marking

Above models conform to EMC directive. (89/336/EEC, 92/31/EEC amendment, 93/68/EEC amendment) EN61326 Emission: Class B Immunity: Table-Minimum immunity test requirement.

Exceptions:

AC powered model (with AC power Adaptor) and analog output model are excluded from CE-marking. When the cord (IR-VHC3) for RS232C is connected to the thermometer, the thermometer becomes the exclusion from CE-marking.

3. Names and functions of component parts

Front

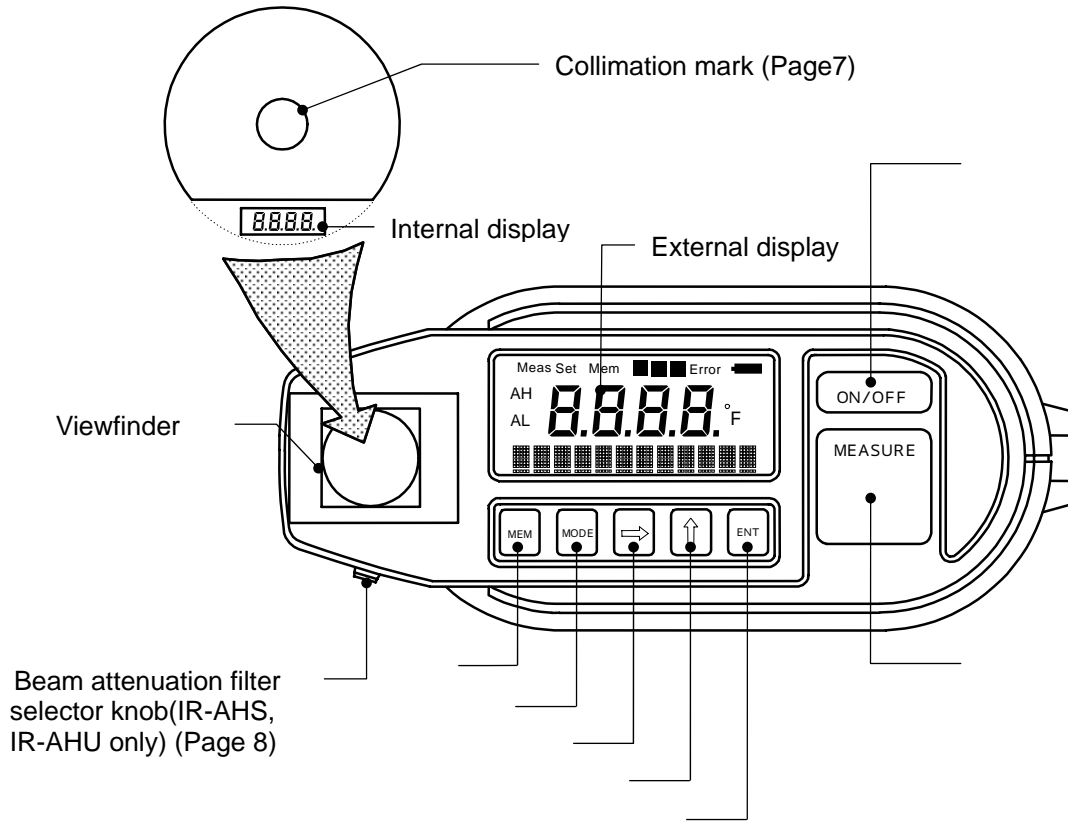

Functions of keys

<u>Keys</u>	<u>Major functions</u>	<u>Indications in this</u>
Power switch	Turns on or off the power supply.	ON/OFF
Measure switch	Starts or stops measurement.	MEASURE
Memory key	Stores the measured data into memory.	MEM
Mode selector key	Selects the screen.	MODE
Shift key	Shifts the digit on programming parameters.	<input type="checkbox"/>
Change key	Changes the numeric at the selected digit on programming parameters.	<input type="checkbox"/>
Entry key	Stores the parameter programmed.	ENT

3. Names and functions of component parts

External display

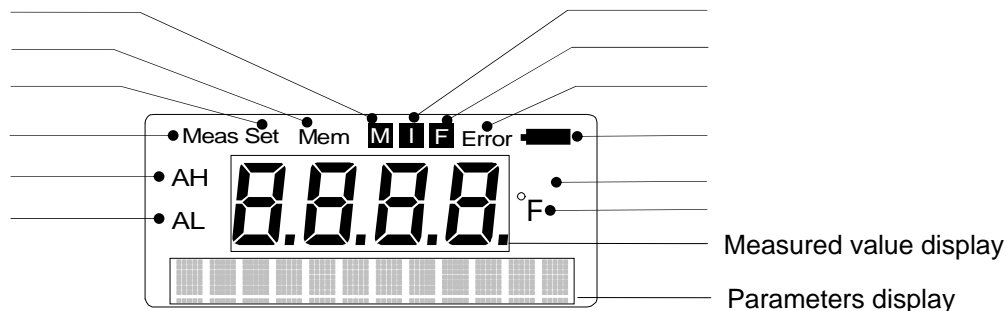

Markers

<u>Markers</u>	<u>Major functions</u>	<u>Indications in this manual</u>
AL	Lights when the low alarm is on.	"AL"
AH	Lights when the high alarm is on.	"AH"
Meas	Lights in measurement.	"Meas"
Set	Lights on programming parameters or system.	"Set"
Mem	Lights on programming memory or display.	"Mem"
M	Lights when the memory function is effective.	M
I	Lights when the interval memory mode is programmed.	I
F	Lights when the memory for data storage has no space.	F
Error	Lights when the internal temperature of thermometer is abnormal.	"Error"
	Lights on low batteries.	
	Lights when the temperature is displayed in °C.	" "
°F	Lights when the temperature is displayed in °F.	"°F"

Left side panel

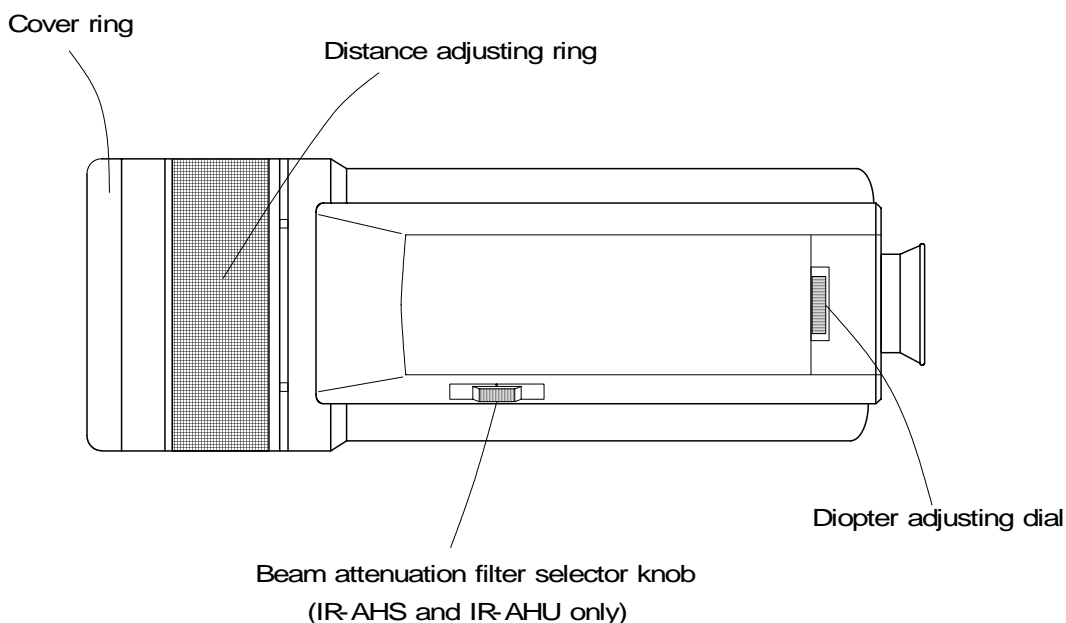

3. Names and functions of component parts

Right side panel

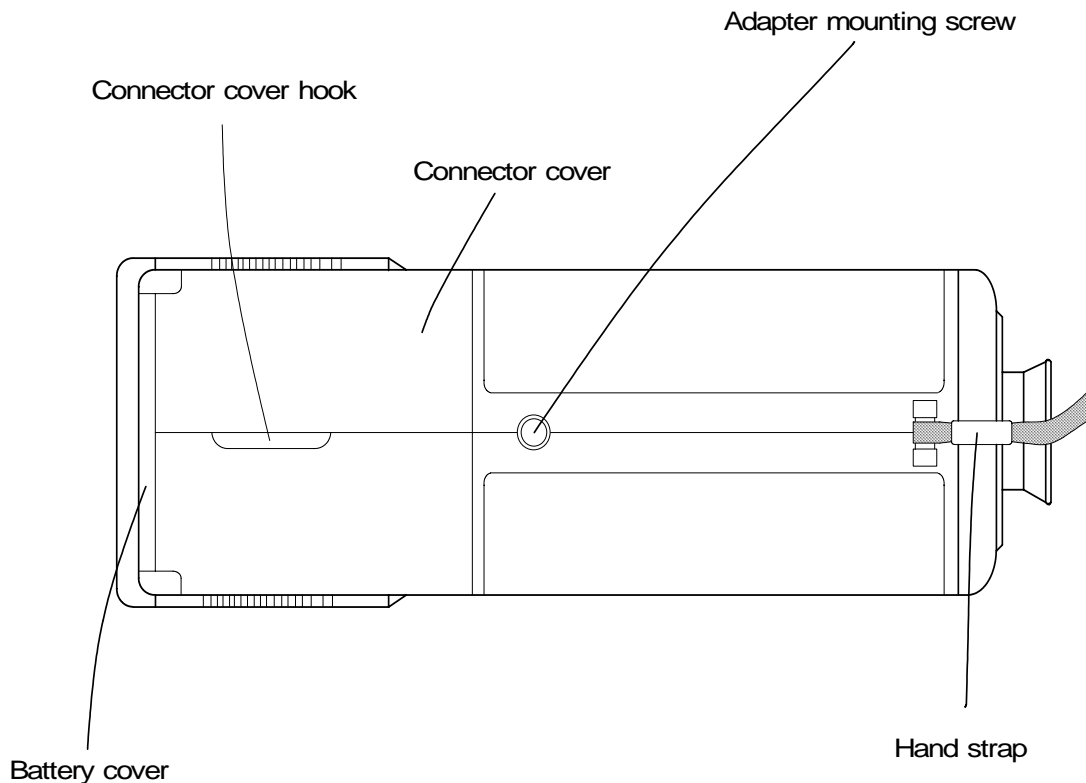

Inside connector cover

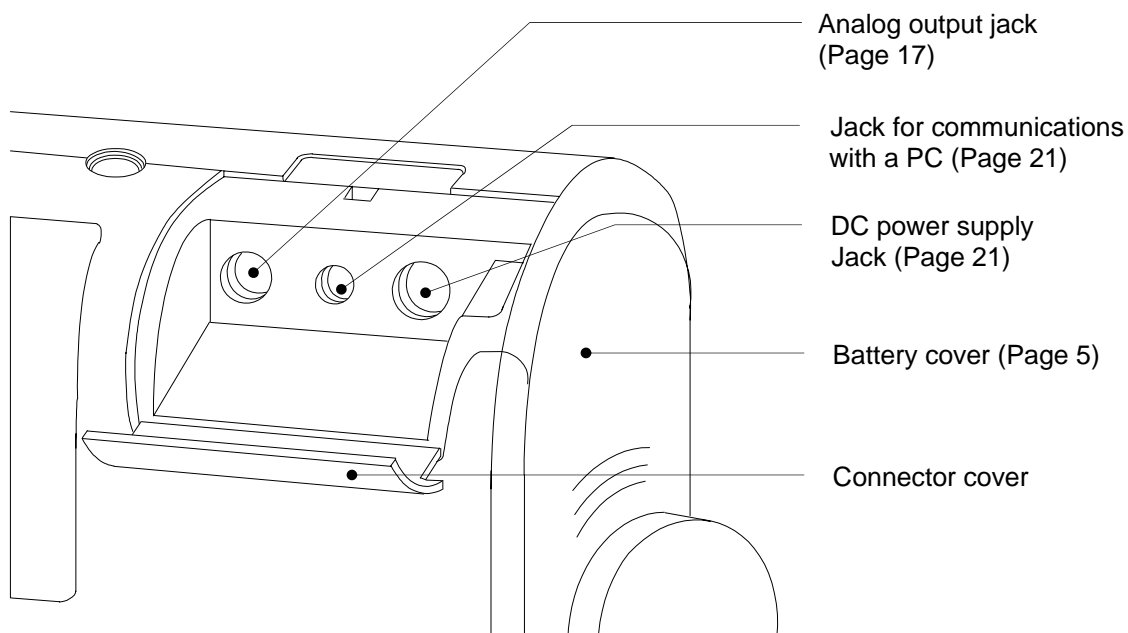

4. Preparation for measurement

4.1 Loading batteries

Removing the battery cover

Remove the battery cover by sliding it in the arrow direction while slightly pushing the asterisked (*) part.

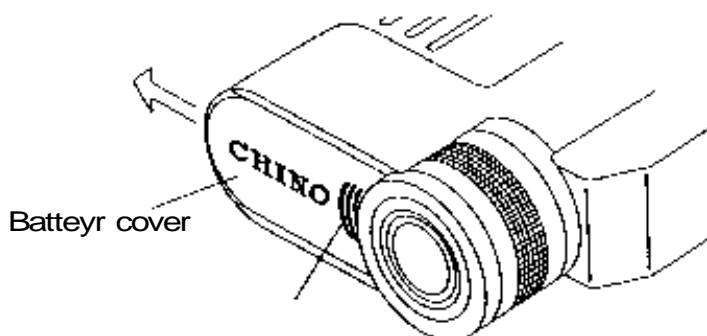

Removing the inside cover

Remove the inside cover by turning the cover fixing screw in the arrow direction by using a coin.

Caution

If you mistakes polarity and insert of the battery, there is the fear that the explosion/liquid leakage of the battery occurs and become the cause of a fire and injury and also contaminate the surroundings.

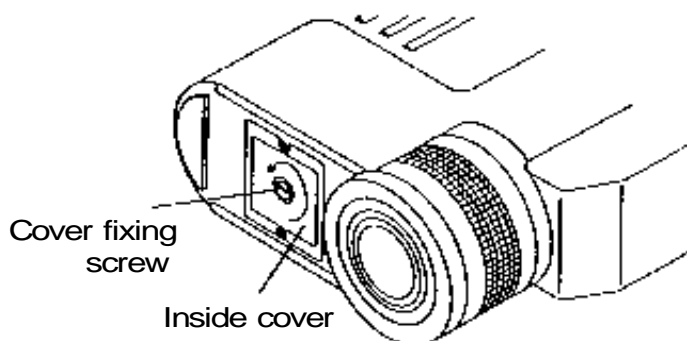

4. Preparation for measurement

Loading batteries

Load the new batteries so that their polarities meet the polarity marks on the battery case.

Caution

The dimensions of the inside cover is as follows.
 Attach and combine the direction of  department B of protrusion department A and inside cover of the battery case.

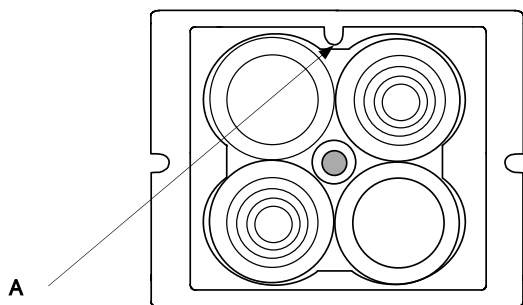
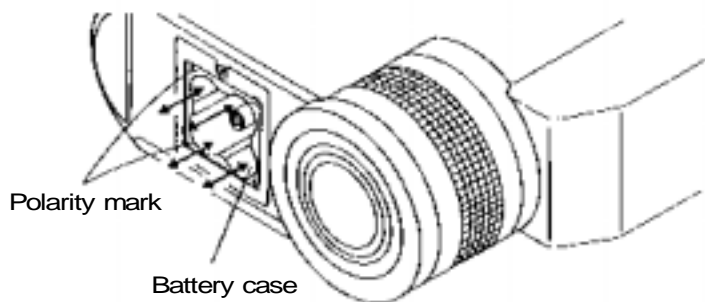

Battery case

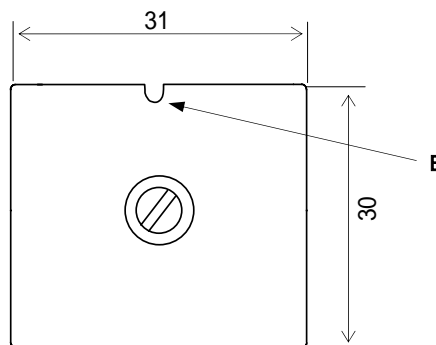

Inside cover

Unit: mm

Mounting the inside cover

Mount the inside cover so that it meets the part.

Mount the battery cover.

4. Preparation for measurement

4.2 Start and stop

4.2.1 Start

Press **ON/OFF** key to turn the power supply on.

This thermometer checks the system just after the power supply has been turned on.

The message “System Check” appears on the parameter display during the system is checked.

S	y	s	t	e	m	C	h	e	c	k
---	---	---	---	---	---	---	---	---	---	---

After the system check is finished, the measurement screen is displayed.

On the measurement screen, the signal modulation mode is displayed at the left side and the emissivity is displayed at the right side of the parameter display at the measurement screen.

Real	E1.00
------	-------

4.2.2 Stop

Press **ON/OFF** key to turn the power supply off.



By pressing **ON/OFF** key, the shutdown processing is executed to save the system information. Make sure to press **ON/OFF** key for turning off the power supply of this thermometer.

4.3 Programming temperature unit

Program the temperature unit by the procedure below.

- Press **ON/OFF** key while pressing **MODE** key to turn the power supply on.
- The temperature unit programming screen appears on the parameter display.

U	n	i	t							
---	---	---	---	--	--	--	--	--	--	--

- Selects °C for Centigrade temperature display or °F for Fahrenheit temperature display by **↑** key.
- Press **ENT** key to store the temperature unit selected.
- Press **ON/OFF** key to turn off the power supply once.

The temperature unit stored is displayed in the next start.



- The default temperature unit is °C.

5. Measuring

5.1 Measuring procedure

- Press **ON/OFF** key to turn the power supply on.
- Set the measuring distance roughly by the distance adjusting ring.
- Adjust the diopter adjusting ring to see the collimation mark on the internal display clearly.
- Adjust the distance measuring ring to see the object measured clearly in the collimation mark.
- Press **MEASURE** key to start the measurement.

The temperature measured is displayed on the internal and external displays, and the “Meas” marker lights on the external display.

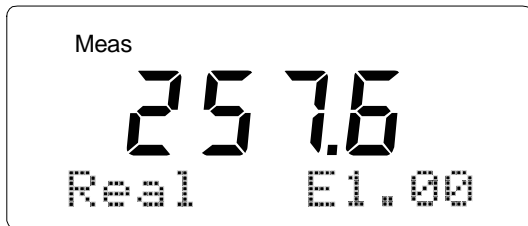

The “OFL” is displayed if the temperature measured exceeds the measuring range or the “UFL” is displayed if it is lower than the measuring range.

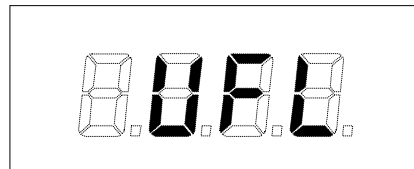
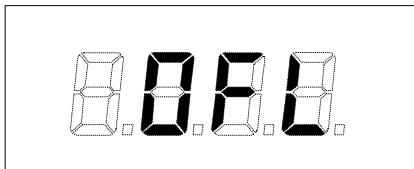

- Release **MEASURE** key to stop the measurement. The temperature measured just before stop is held on the internal and external displays.

5.2 Continuous measurement

For the continuous measurement, press **ON/OFF** key while pressing **MEASURE** key to turn the power supply on. Press **MEASURE** key to start the measurement. The measurement is continued until **MEASURE** key is pressed again.

Reference

- Batteries are consumed abruptly on the continuous measurement . It is recommended to use the AC adapter Model IR-VHR (option) for the continuous measurement.

5.3 Auto power off

The back-light for internal display lights out in 10 seconds after the stop of measurement.

On the continuous measurement, it lights out in 10 seconds after the start of measurement.

For lighting the back-light again, press **ENT** key. The back-light lights for 10 seconds.

For saving the battery life, the power supply is turned off automatically if this thermometer is not operated for 5 minutes

5. Measuring

5.4 Cautions on measurement



Warning

- Never directly face the objective lens to the sunlight for protecting your eyes and the detecting element.
- Set the beam attenuation filter selector knob to the beam attenuation side in advance (in case of Model IR-AHS or IR-AHU) for protecting your eyes on the measurement of object exceeding 1500°C.
- **However , when you feel glare on the measurement of objects lower than 1500 °C, set the beam attenuation filter selection knob to the beam attenuation side in advance.**

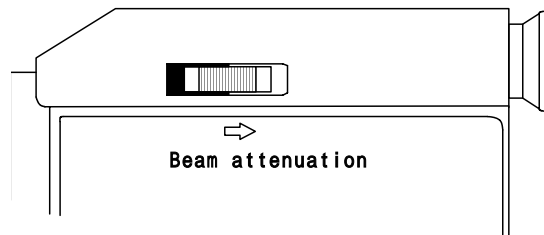

Caution

- **Light path**
Be careful not to introduce water drops, dust particles, smoke, steam, or other foreign substances into the light path between the object measured and the objective lens of this thermometer.
- **Interference causing high indication**
Be careful not to apply the direct sunlight, light of an incandescent lamp, flame or other thermal radiation to the object measured and the objective lens of this thermometer.
- **Abrupt change of ambient temperature**
Model IR-AHT uses a thermopile as its detecting element. If the ambient temperature changes abruptly, it takes time until the indication is stabilized. If your thermometer is Model IR-AHT and it has been brought into a place where a temperature difference is noticeable, leave the thermometer for about one hour before starting the measurement.

5. Measuring

5.5 Measuring

This thermometer has various measuring parameters.

The list of parameters is shown in [11. List of starting modes/screens]. By pressing **MODE** key when the measurement screen is displayed, the measuring parameter programming screen is appears with the “Set” marker lit. Measuring parameters cannot be programmed in measurement. For programming the parameters, cancel the measurement once.

5.5.1 Programming emissivity

If the emissivity of object measured is low, the temperature displayed becomes lower than the actual temperature and the emissivity is to be compensated.

- Press **MODE** key to get the emissivity programming screen.



- Press **→** key to shift the digit and press **↑** key to program the emissivity.
- Press **ENT** key to store the emissivity programmed.

The programming range is 0.10 to 1.99 (0.01 step).

Remarks	• The default emissivity is 1.00.
----------------	-----------------------------------

Reference	• If you know the emissivity of object measured, program to its value. If the emissivity is unknown, measure the temperature of object by a thermocouple or other sensors and program the emissivity to display the same temperature. The reference table of emissivity is shown in [13. Emissivity table]
------------------	--

5.5.2 Programming signal modulation mode

The maximum value, average value, and minimum value can be extracted continuously from the measurement signal (real signal).

- Press **MODE** key to get the signal modulation mode programming screen.

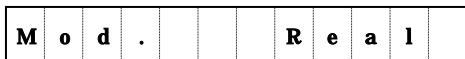

- Press **↑** key to program the mode.

Real	The temperature measured is displayed on the real signal without any signal modulation.
Peak	When the temperature measured increases, it is displayed on the real signal. When the temperature measured decreases, it is displayed on the first-order lag signal by the time constant being programmed by the modulation time constant programming.
Delay	The temperature measured is displayed on the first-order lag signal.
Valley	When the temperature measured decreases, it is displayed on the real signal. When the temperature measured increases, it is displayed on the first-order lag signal by the time constant being programmed by the modulation time constant programming.

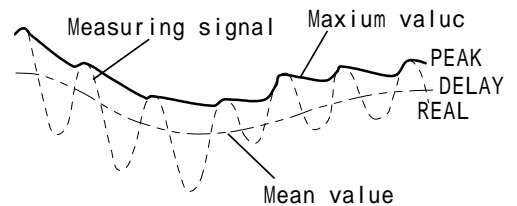

- For the first-order lag degree in peak, delay, and valley, refer to [5.5.3 Programming modulation time constant].

- Press **ENT** key to store the modulation mode programmed.

Remarks	• The default mode is Real.
----------------	-----------------------------

5. Measuring

5.5.3 Programming modulation time constant

The modulation time constant is programmed on the signal modulation modes. The first-order lag degree can be adjusted by the modulation time constant. The increase of modulation time constant makes the first-order lag degree increase and the temperature measured is displayed smoothly.

- Press **MODE** key to get the modulation time constant programming screen.

T	.	C	.			9	9	.	9	s
---	---	---	---	--	--	---	---	---	---	---

- Press **→** key to shift the digit and press **↑** key to program the modulation time constant.
- For programming to Hold, increase the value by **↑** key at the most significant digit to display “Hold”.

T	.	C	.			H	o	l	d	?
---	---	---	---	--	--	---	---	---	---	---

- Press **[ENT]** key to store the time constant programmed.

The programming range of the modulation time constant is 0.0 to 99.9 seconds (0.1 second step) and “Hold”.

Remarks

- The default time constant is 0.0 second.

Reference

- Operation when the modulation time constant is programmed to “Hold”.
By programming the signal modulation mode to Peak, the maximum temperature in measurement is held. By programming the signal modulation mode to Valley, the minimum temperature in measurement is held.
By programming the signal modulation mode to Delay, the temperature measured is displayed on condition that the modulation time constant is 99.9 seconds

5.5.4 Programming alarms

Two kinds of high alarm and low alarm can be programmed. If an alarm is on, either the “AH” (high alarm) or the “AL” (low alarm) marker lights on the external display and the buzzer sounds. Program to “OFF” if no alarm is required.

- Press **MODE** key to get either the high alarm programming screen (left figure) or the low alarm programming screen (right figure).

A	l	m	H			O	f	f		
---	---	---	---	--	--	---	---	---	--	--

A	l	m	L			O	f	f		
---	---	---	---	--	--	---	---	---	--	--

- Press **→** key to shift the digit and press **↑** key to program the alarm value
- For programming to OFF, increase the value by **↑** key at the most significant digit to display “OFF”.
- Press **ENT** key to store the alarm value programmed.

Alarm programming range

Model	High alarm programming range	Low alarm programming range
IR-AHT	-50 ~ 1000 °C (1°C step) OFF	-50 ~ 1000 °C (1°C step) OFF
IR-AHS	600 ~ 3000 °C (1°C step) OFF	600 ~ 3000 °C (1°C step) OFF
IR-AHU	900 ~ 3000 °C (1°C step) OFF	900 ~ 3000 °C (1°C step) OFF

Remarks

- The default high and low alarms are “OFF”.

6. Temperature data storage



This thermometer provides a function of storing temperature data measured up to maximum 1000 data into memory.

Two kinds of storage modes are prepared. The manual storage mode is to store the temperature data being measured at the time pressing [MEM] key, and the storage-with-interval mode is to store the temperature data being measured at every interval time programmed.

6.1 Manual storage mode

- Press [MODE] key for about 2 seconds on the measurement screen to get the storage mode programming screen.

M	M	O	D					O	f	f
---	---	---	---	--	--	--	--	---	---	---

- Press  key for programming to “Man”.
- Press  key to store the manual storage mode.

The  marker lights when the manual storage mode is stored.

Mem	
-----	---

- Press [MODE] key for returning to the measurement screen.
- Press [MEASURE] key to start the measurement.
- In measurement, press [MEM] to store the temperature data being measured at the time into memory and the message “Data Stored” appears at the temperature data storage.

D	a	t	a	S	t	o	r	e	d
---	---	---	---	---	---	---	---	---	---

In-not-measurement, by pressing  key, the temperature data being displayed at the time is stored into memory. (When a data is stored once in-not-measurement, any data after then can not be stored until the measurement is executed again.)

To make the memory function disable, program to “Off” in the storage mode programming screen.  key does not function and the temperature data are not stored into memory.

Remarks

- The default memory mode is “Off”.

6. Temperature data storage

6.2 Storage-with-interval mode

- Press [MODE] key for about 2 seconds on the measurement screen to get the storage mode programming screen.

M	M	O	D					O	f	f
---	---	---	---	--	--	--	--	---	---	---







- Press  key for programming to “Int”.
- Press  key to store the storage-with-interval mode.

The  marker lights when the storage-with-interval mode is stored.

Mem	
-----	---

- Press  key once to get the interval time programming screen.

I	n	t		0	:	0	1	:	0	0
---	---	---	--	---	---	---	---	---	---	---

- Press  key to shift the digit and press  key to program the interval time.
- Press [ENT] key to store the interval time programmed. On this stage, the storage-with-interval function does not activate.
- Press  key for about 2 seconds to get the measurement screen.
- Press  key to make the storage-with-interval function activate. The  marker lights in addition to the  marker on the function activated.

	
---	---

- Press  key to start the measurement. The temperature data at every interval time programmed are stored into memory and the message “Data Stored” appears each time at the temperature data storage.

D	a	t	a		S	t	o	r	e	d
---	---	---	---	--	---	---	---	---	---	---

- To cancel the storage-with-interval function temporarily, press  key. The  marker lights out.

The programming range of interval time is 1 second to 2 hours (0:00:01 to 2:00:00).

Remarks

- The default interval time is 1 minute (0:01:00).

6. Temperature data storage

6.3 Display of data stored

- Press **MODE** key for about 2 seconds on the measurement screen to get the storage mode programming screen.
- Press **MODE** key to display the temperature data stored. .

Index numbers (serial number from 1 to 1000 showing data storing numbers) are displayed on the left side and temperature data are displayed on the right side.

The temperature data stored into memory last is displayed first.

			1				1	0	0	0
--	--	--	---	--	--	--	---	---	---	---

- Press **→** key to display the previous temperature data stored before the temperature data displayed. Press **↑** key to display the next temperature data stored after the temperature data displayed.
- Press **MODE** key for about 2 seconds to cancel the display of temperature data stored.

The message “No Data” appears if any temperature data have not been stored.

6.4 Number of temperature data stored

Maximum 1000 temperature data can be stored into memory. The temperature data exceeding 1000 cannot be stored and the **F** marker lights on 1000 temperature data stored.

Meas		M	F
------	--	----------	----------

To store the temperature data under this condition newly, delete the previous temperature data referring to [6.5 Deletion of last storage data] and [6.6 Deletion of all storage data].

6.5 Deletion of last storage data

- The following procedure is to delete the last temperature data stored.
- Press **MODE** key for about 2 seconds on the measurement screen to get the storage mode programming screen.
- Press **MODE** key to get the last temperature data deletion screen.

L	D	D	E	L	Y	E	S	N	O
---	---	---	---	---	---	---	---	---	---

- Press **→** key to shift the cursor to “Yes”.
- Press **ENT** key.

When the data is deleted normally, the message “xxxx Erased” appears. This “xxxx” shows the index number of the temperature data deleted.

		1	0	E	r	a	s	e	d
--	--	---	---	---	---	---	---	---	---

The message “No Data” appears if any temperature data have not been stored.

- Press **MODE** key for about 2 seconds to cancel the last temperature data deletion.

6. Temperature data storage

6.6 Deletion of all storage data

- The following procedure is to delete all temperature data stored,
- Press **MODE** key for about 2 seconds on the measurement screen to get the storage mode programming screen .
- Press **MODE** key to get all temperature data deletion screen .

A	D	D	E	L	Y	E	S	N	O
---	---	---	---	---	---	---	---	---	---

- Press **→** key to shift the cursor to “Yes”.
- Press **ENT** key.

When the data are deleted normally, the message “All Erased” appears.

1	0	E	r	a	s	e	d
---	---	---	---	---	---	---	---

The message “No Data” appears if any temperature data have not been stored.

- Press **MODE** key for about 2 seconds to cancel all temperature data deletion.

7. User calibration

For the routine calibration of this thermometer, the user calibration function is provided to recalibrate this thermometer by using your black body furnace for calibration.

The calibration is executed on two optional temperature points.

7.1 Calibration method

- Press **ON/OFF** key while pressing **MODE** key to turn the power supply on.
- Press **MODE** key several times to get the zero/span calibration execution screen.

C	M	P				G	O			N	O
---	---	---	--	--	--	---	---	--	--	---	---

- Press **→** key to shift the cursor to “GO”.

Reference

Press **MODE** key on this condition, when you want to calibrate the span side only without calibration the zero side.

- Press **ENT** key to get the zero side calibration data programming screen.

The temperature data being displayed is on the real signal not being converted through emissivity compensation, signal modulation, and modulation time constant.

Meas Set											
6 12											
Zero 600c?											

- Measure the temperature of your black body furnace.
- During the measurement of the black body furnace temperature, press **→** key to shift the digit and press **↑** key to change the temperature displayed to the calibrated temperature of black body furnace

Caution

Use the **↑** key in the case that the numerical value is set up. However, do it after the column that sets up the numerical value is selected with the **→** key. If push the **↑** key without selecting the column, transferring it to the upper most column and the numerical value has done UP.

- Press **ENT** key to store the calibration data at the zero side.

As the confirmation of calibration data storage, the asterisk (*) appears beside the character “Zero”.

Z	e	r	o	*			7	0	0		
---	---	---	---	---	--	--	---	---	---	--	--

Caution

The auto power off function works when time is required to the span side calibration work start after zero side calibration ended, and the power supply becomes the condition of off.
(In the case that there is not key operation for 5 minutes)

- Press **MODE** key once to get the span side calibration data calibration screen.

S	p	a	n				3	0	0	0	
---	---	---	---	--	--	--	---	---	---	---	--

8. Analog Output

If your thermometer is with the optional analog output function, the analog output of 0 to 1V corresponding to the temperature data measured. (Models IR-AHT2, IR-AHS2 and IR-AHU2)
 You can record the temperature data measured on a recorder by this function

8.1 Programming scale

An optional temperature scaling to an analog output of 0 to 1V can be programmed.

- Press **ON/OFF** key while pressing **MODE** key to turn the power supply on.
- Press **MODE** key once to get the high output scaling value programming screen.

O	H					2	0	0	0
---	---	--	--	--	--	---	---	---	---

- Press **→** key to shift the digit and press **↑** key to program the high output scaling value.
- Press **ENT** key to store the high output scaling value programmed.
- Press **MODE** key once more to get the low output scaling value programming screen.

O	L					1	0	0	0
---	---	--	--	--	--	---	---	---	---

- Press **→** key to shift the digit and press **↑** key to program the low output scaling value.
- Press **ENT** key to store the low output scaling value programmed.
- Press **ON/OFF** key to turn the power supply off.

On the next start-up of this thermometer, you can get the analog output of 0 to 1V within the scaling range programmed.

The analog output programming range is mentioned below.

Model	High output scaling value programming range	Low output scaling value programming range
IR-AHT	-50 to 1000 °C(1°C step)	-50 to 1000 °C(1°C step)
IR-AHS	600 to 3000 °C(1°C step)	600 to 3000 °C(1°C step)
IR-AHU	900 to 3000 °C(1°C step)	900 to 3000 °C(1°C step)

Remarks

- The default scaling values
 IR-AHT 1000 °C (Maximum scaling), -50 °C (Minimum scaling)
 IR-AHS 3000 °C (Maximum scaling), 600 °C (Minimum scaling)
 IR-AHU 3000 °C (Maximum scaling), 900 °C (Minimum scaling)

8.2 Connections

Connect the analog output cable attached to the analog output jack inside the connector cover. Connect it to the innermost of the jack securely.

For the place of the analog output jack, refer to [3. Names and functions of component parts].

8.3 Temperature data on analog output

The temperature data on analog output are the same as those being displayed and the data are converted through emissivity compensation, signal modulation, and modulation time constant.

9. Maintenance and check

9.1 Self-diagnostic function

9.1.1 Low battery

The battery warning marker lights on the external display when the battery capacity becomes lower than a certain level and replace them at once with the new batteries.

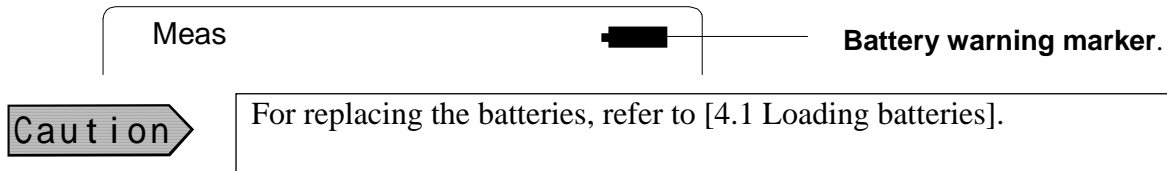

9.1.2 Abnormal internal temperature

If the temperature inside this thermometer becomes abnormal, the inside temperature error marker lights on the external display.

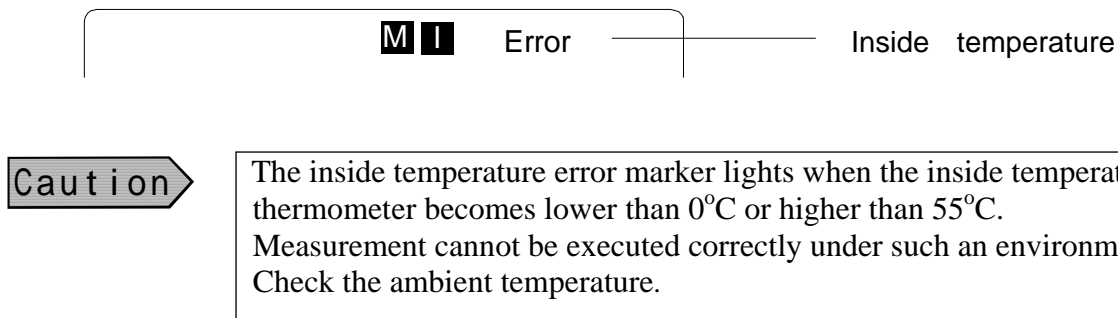

9.1.3 EEPROM error

If EEPROM storing the parameters and the temperature data becomes in error, the message “EEPROM ERROR” appears at the access timing to EEPROM.

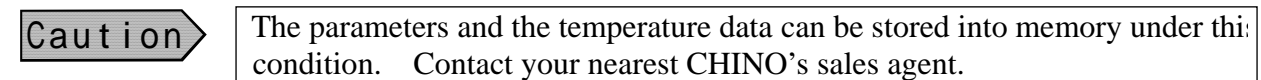
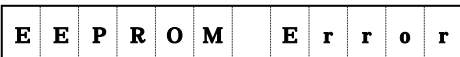

9.1.4 Status display

If key is pressed for about 2 seconds on the measurement screen in the stop condition, the status of this thermometer are displayed on the external display. Press key to switch the screens. The following status are displayed.

- Inside temperature
- Model
- Serial number
- Measuring temperature range
- Measuring wavelength

Press key for about 2 seconds for returning to the measurement screen.

9. Maintenance and check

9.2 Storage

Caution

- Don't store this thermometer at a hot and/or wet place.
- Make sure to mount the lens cap for storage.
- Remove the batteries if this thermometer is not used for longer than 2 weeks, otherwise this thermometer may become defective due to an electrolyte leak failure of the batteries.

9.3 Cleaning of cover glass

Wipe the cover glass inserted into the cover ring periodically with a soft cloth.

In case of Model IR-AHT, the cover glass is mounted at a deep position. Remove the ring from the thermometer to wipe the cover glass.

9.4 Cleaning of external display and eyepiece cover

Clean them periodically with a soft cloth.

9.5 Initializing to default condition

For initializing this thermometer to the default condition, press **ON/OFF** key while pressing **ENT** and **↑** keys. The message "Initialized" appears to confirm the initialization.

I n i t i a l i z e d

Caution

- By this operation, all parameters are initialized to the default condition and the temperature data stored are erased.

Remarks

- For the default parameters, refer to [11.2 Table of screens]

10. Accessories

10.1 Close-up lens (Model: IR-VHD: For IR-AHS and IR-AHU)

This lens is used for the measuring distance less than 0.5m.

The measuring diameter is determined by the distance factor. The measuring diameter is expressed by the following formula.

$$(\text{Measuring diameter}) / (\text{Measuring factor}) = \text{Measuring diameter } \phi D \text{ (Unit: mm)}$$

(Example) As the distance factor of Model IR-AHS is 100, the relation of measuring distance and measuring diameter is shown as:

$$250 \text{ to } 520/100 = \phi 2.5 \text{ to } \phi 5.4 \text{ (Unit: mm)}$$

The measuring distances and the measuring diameters of each model are shown in the table. In case of Model IR-AHS, it is possible to measure the object with the diameter of $\phi 1$ at the measuring distance of 100 mm.

Model	Distance	Min. diameter (IR-AHS)	Min. diameter (IR-AHU)
IR-VHD13	100 to 130(mm)	1 to 1.3(mm)	
IR-VHD18	130 to 180(mm)	1.3 to 1.8(mm)	
IR-VHD29	180 to 290(mm)	1.8 to 2.9(mm)	0.7 to 1.2(mm)
IR-VHD54	250 to 540(mm)	2.5 to 5.4(mm)	1.0 to 2.2(mm)

Mounting Method

- Remove the cover glass ring from the lens cylinder tip by turning it.
- Mount the close-up lens to the lens cylinder tip by screwing it.

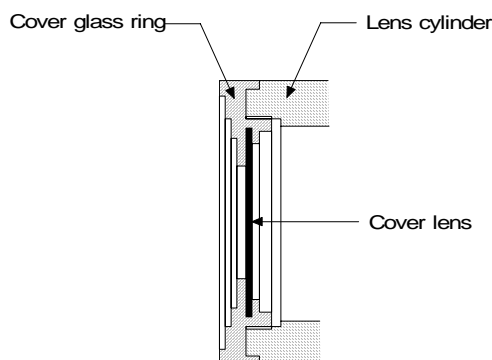

Remarks

- No cover glass can not be used for the close-up lens.

10. Accessories

10.2 AC adapter (Model IR-VHRA)

The adapter is for operation of this thermometer with AC power supply and is effective for use in the continuous measurement mode.

For the connection, insert the plug of the adapter into the DC power jack. For the place of the DC power jack, refer to [Inside connector cover] in [3. Names and functions of component parts].

Warning

- Make sure that 100VAC is used for the AC adapter. If not, electrical shock, fire, damage may occur.
- Do not touch the AC adapter or receptacle with wet hands.
- Do not wet the AC adapter. Fire may cause.
- Wipe out the dust on the AC adapter. Fire may cause.

Caution

- Connect the AC adapter to this thermometer with the power supply turned off.

10.3 Tripod (Model IR-ZBMT) and Universal head (Model IR-VMS)

These accessories are used for fixing this thermometer for long-term measurement.

Mount the tripod or the universal head via the tripod mounting adapter attached, if required.

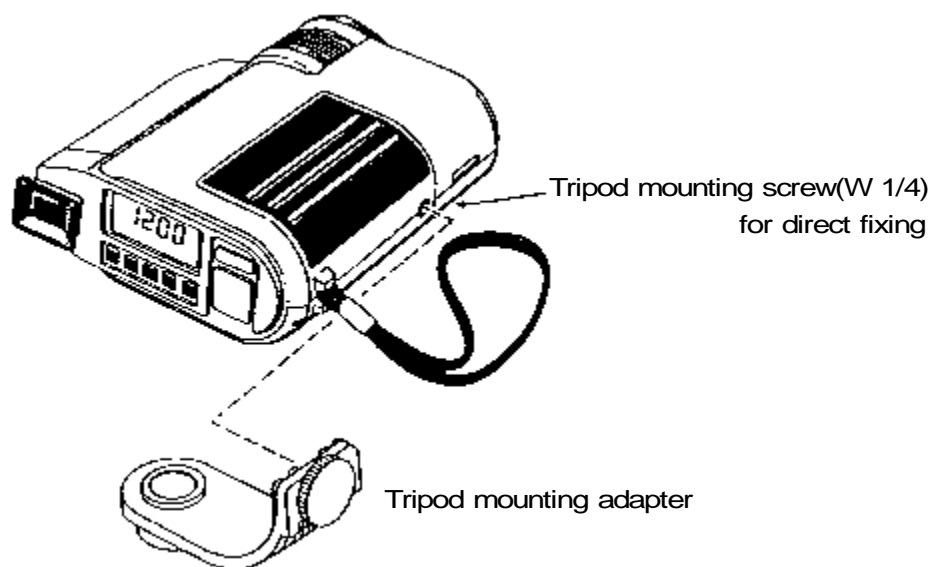

10.4 Data Logging Software (IR-AH Data Logging Software)

Three kinds of data management mode, real-time trend mode, multi-point monitoring mode by utilizing memory, and 1-point historical trend mode, are available.

Graph display, report creation, printing, and data storage can be easily executed.

The export of the measured data to spreadsheet applications is also possible.

11. List of Starting Modes/Screens

11.1 Modes at start time

The following operation modes are available by the key combinations at the start time.

Keys	Modes	Remarks
Press ON/OFF key only	Standard measurement	
Press ON/OFF while pressing MEASURE key	Continuous measurement	
Press ON/OFF key while pressing MODE key	System programming	No measurement can be executed.
Press ON/OFF key while pressing ENT and □ keys together	Initialization	After initialization, the standard measurement is executed.

11.2 Table of screens

The screens displayed on the external display are the following 4 kinds basically.

Modes	How-to-display from measurement screen	Makers appeared	Return to measurement screen
Programming measuring parameters	Press MODE key.	"Set"	Press MODE key on the low alarm programming screen.
Programming and display on temperature data storage	Press MODE key for 2 seconds.	"Mem"	Press MODE key for 2 seconds. (Enable from any screen)
Status display	Press □ key for 2 seconds.		Press □ key for 2 seconds. (Enable from any screen)
System programming	Press ON/OFF key while pressing MODE key to turn the power supply on.	"Set"	

For changing screens, press **MODE** key.

11.2.1. Measuring parameters programming/display items

Screen	Display	Programming range	Default
Emissivity	Emi.	0/10 to 1.99	1.00
Signal modulation mode	Mod.	Real, Peak, Valley, Delay	Real
Signal modulation time constant	T.C.	0.0 to 99.9 seconds, HOLD	0.0 second
High alarm	AlmH	-50 to 1000 °C, OFF (IR-AHT) 600 to 3000 °C, OFF (IR-AHS) 900 to 3000 °C., OFF (IR-AHU)	OFF
Low alarm	AlmL	-50 to 1000 °C, OFF (IR-AHT) 600 to 3000 °C, OFF (IR-AHS) 900 to 3000 °C., OFF (IR-AHU)	OFF

11.2.2. Temperature data storage programming/display items

Screen	Display	Programming range	Default
Storage mode	MMOD	OFF, Man, Int	OFF
Interval time programming	Int	00:00:01 to 02:00:00	00:01:00
Storage data display			
Last storage data deletion	LDDEL		
All storage data deletion	ADDEL		

The interval time programming screen is only displayed when the storage mode is programmed to "Int".

11. List of Starting Modes/Screens

11.2.3 Status display items

Screen	Display
Inside temperature	Dtemp
Model	Model
Serial number	SN
Measuring temperature range	R
Measuring wavelength	WL

11.2.4. System programming display items

Screen	Display	Programming range	Default
Temperature unit	Unit	°C, °F	°C
Output scaling high limit *1	OH	-50 to 1000 °C (IR-AHT) 600 to 3000 °C (IR-AHS) 900 to 3000 °C (IR-AHU)	1000 °C (IR-AHT) 3000 °C (IR-AHS) 3000 °C (IR-AHU)
Output scaling low limit *1	OL	-50 to 1000 °C (IR-AHT) 600 to 3000 °C (IR-AHS) 900 to 3000 °C (IR-AHU)	-50 °C (IR-AHT) 600 °C (IR-AHS) 900 °C (IR-AHU)
Zero/span calibration execution	CMP		
Calibration data programming at zero side *2	Zero	-50 to 1000 °C (IR-AHT) 600 to 3000 °C (IR-AHS) 900 to 3000 °C (IR-AHU)	-50 °C (IR-AHT) 600 °C (IR-AHS) 900 °C (IR-AHU)
Calibration data programming at span side *2	Span	-50 to 1000 °C (IR-AHT) 600 to 3000 °C (IR-AHS) 900 to 3000 °C (IR-AHU)	1000 °C (IR-AHT) 3000 °C (IR-AHS) 3000 °C (IR-AHU)
Calibration operation execution *2	CAL		
Calibration data recovery *2	Undo		

*1: The output scaling high limit and output scaling low limit are only displayed on the thermometers with analog output (option).

*2: The screens for the zero side calibration data programming, the span side calibration data programming, the calibration operation execution and the calibration data recovery are only displayed when you select “GO” on the zero/span calibration execution screen.

12. General Specifications

12.1 External dimensions

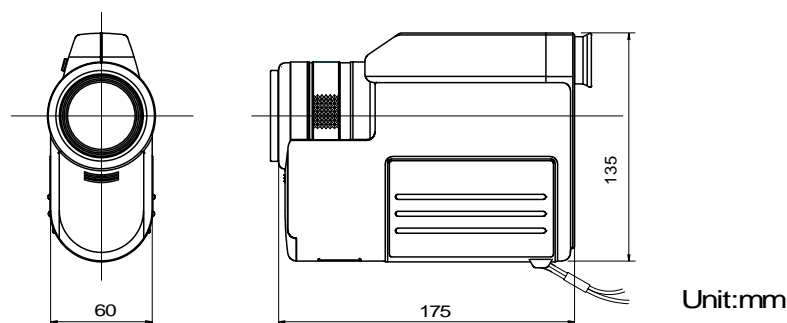

12. General Specifications

12.2 Specifications

Model	IR-AHS	IR-AHU	IR-AHT
Measuring System	Narrow band radiation thermometer		Wide band radiation thermometer
Detecting Element	Si		Thermopile
Measuring Wavelength	0.96 μ m	0.65 μ m	8 to 13 μ m
Measuring Range	600 to 3000 $^{\circ}$ C	900 to 3000 $^{\circ}$ C	-50 to 1000 $^{\circ}$ C
Accuracy Ratings	Lower than 1500 $^{\circ}$ C: $\pm 0.5\%$ of measured value ± 1 digit 1500 $^{\circ}$ C to 2000 $^{\circ}$ C: $\pm 1\%$ of measured value ± 1 digit Higher than 2000 $^{\circ}$ C: $\pm 2\%$ of measured value ± 1 digit ($\gamma = 1.0$, Reference operating condition: 23 $^{\circ}$ C $\pm 5^{\circ}$ C, 35 to 75%RH)		Lower than 200 $^{\circ}$ C: $\pm 2^{\circ}$ C ± 1 digit High than 200 $^{\circ}$ C: $\pm 1\%$ of measured value ± 1 digit
Repeatability	1 $^{\circ}$ C ± 1 digit		
Stability	1) Temperature drift: 0.015% of measured value / $^{\circ}$ C 2) Stability: $\pm 5^{\circ}$ C under EMC test environment		1) Temperature drift: Lower than 300 $^{\circ}$ C: 0.15 $^{\circ}$ C/ $^{\circ}$ C 300-700 $^{\circ}$ C: 0.05% of measured value / $^{\circ}$ C Higher than 700 $^{\circ}$ C: 0.025% of measured value / $^{\circ}$ C 2) Stability: $\pm 15^{\circ}$ C under EMC test environment
Resolution	1 $^{\circ}$ C		1 $^{\circ}$ C (More than 50 $^{\circ}$ C)
Response Time	0.5 second		1 second
Emissivity Compensation	=1.00 to 0.10 (0.01 increment)		
Signal Modulation	modulation : Real, Peak, Delay, and Valley . modulation ratio: 0 to 99 seconds, 1-sec increment Peak hold, Valley hold, Hold with the measuring switch turned off.		
Display System	LCD digital 4 digits, Displayed in the finder and on the panel board		
Data Storage Function	Maximum 1000 data		
Users' Calibration Function	Calibration at zero and span		
Output Signal	Digital transmission (RS-232C), Analog output (0 to 1V DC, option) with a cord		
Communications Function	RS-232C (The data logging software is sold separately.)		
Optical System	Focusable lens type		Cassegrain focusable mirror type
Distance Factor	100(Measuring distance L / Measuring diameter D)	250 (Measuring distance L / Measuring diameter D)	40 (Measuring distance L / Measuring diameter D)
Measuring Distance	L = 500mm to		L = 700mm to
Measuring Diameter	D = L / 100(ϕ , mm)	D = L / 250(ϕ , mm)	D = L / 40(ϕ , mm)
Collimation	Direct viewing finder		
Lens Diameter	ϕ 30mm		ϕ 40mm
Other Functions	Auto-power-off, Continuous measurement, $^{\circ}$ C / $^{\circ}$ F selection, Battery check, High / low alarms		
Ambient Temperature	0 to 50 $^{\circ}$ C		
Power Supply	AA (UM-3) battery, 4 pieces (about 20 hours for continuous measurement)		
Casing Material and Color	ABS resin, Gray		
Outside Dimensions and Weight	W135 x H60 x D175mm, About 700g (thermometer only)		
Attachment	4 pieces of AA (UM-3 battery), Adapter for tripod, Housing case		

13. Emissivity table

The emissivity are values determined by the material of object, profile of its surface, surface roughness, oxidized or not, measuring temperature, measuring wavelength and other factors.

They are represented by the thermal radiation ratio " ϵ " when a black body furnace at the same temperature is measured in the same wavelength band.

The emissivity " ϵ " is generally known by a value at the wavelength of $0.65\mu\text{m}$ when an optical pyrometer is used. The emissivity changes according to the above factors even in case of the same material. Please use the following table as a reference.

13.1 Emissivity table ($\lambda = 0.65\mu\text{m}$)

Metal	Emissivity		Oxide	Emissivity
	Solid	Liquid		
Zinc	0.42		Alumel (*)	0.87
Alumel	0.37		Chromel(*)	0.87
Aluminum	0.17	0.12	Constantan (*)	0.84
Antimony	0.32		Ceramics	0.25 to 0.5
Iridium	0.30		Cast iron (*)	0.70
Yttrium	0.35	0.35	55Fe. 37.5Cr. 7.5Al (*)	0.78
Uranium	0.54	0.34	70Fe. 23Cr. 5Al. 2Co (*)	0.75
Gold	0.14	0.22	80Ni. 20Cr (*)	0.90
Silver	0.07	0.07	60Ni. 24Fe. 16Cr (*)	0.83
Chromium	0.34	0.39	Stainless steel (*)	0.85
Chromel P	0.35		Aluminum oxide	0.22 to 0.4
Cobalt	0.36	0.37	Yttrium oxide	0.60
Constantan	0.35		Uranium oxide	0.30
Zirconium	0.32	0.30	Cobalt oxide	0.75
Mercury		0.23	Columbium oxide	0.55 to 0.71
Tin	0.18		Zirconium oxide	0.18 to 0.43
Carbon	0.8 to 0.9		Tin oxide	0.32 to 0.60
Tungsten	0.43		Cerium oxide	0.58 to 0.82
Tantalum	0.49		Titanium oxide	0.50
Cast iron	0.37	0.40	Iron oxide	0.63 to 0.98
Titanium	0.63	0.65	Copper oxide	0.60 to 0.80
Iron	0.35	0.37	Thorium oxide	0.20 to 0.57
Copper	0.10	0.15	Vanadium oxide	0.70
Thorium	0.54	0.34	Beryllium oxide	0.07 to 0.37
Nickel	0.36	0.37	Magnesium oxide	0.10 to 0.43
80Ni /20Cr	0.35			
60Ni / 024Fe / 16Cr	0.36		(*) : Oxidized on surfaces	
Platinum	0.30	0.38		
90Pt / 10Rh	0.27			
Palladium	0.33	0.38		
Vanadium	0.35	0.35		
Bismuth	0.29			
Beryllium	0.61	0.61		
Manganese	0.59	0.59		
Molybdenum	0.37	0.40		
Rhodium	0.24	0.30		

13. Emissivity table

13.2 Emissivity table ($\lambda = 0.9\mu\text{m}$)

Metal	Emissivity
Aluminum	0.10 to 0.23
Gold	0.015 to 0.02
Chrome	0.36
Cobalt	0.28 to 0.30
Iron	0.33 to 0.36
Copper	0.03 to 0.06
Tungsten	0.38 to 0.42
Titanium	0.50 to 0.62
Nickel	0.26 to 0.35
Platinum	0.25 to 0.30
Molybdenum	0.28 to 0.36

Alloy	Emissivity
Inconel X	0.40 to 0.60
Inconel 600	0.28
Inconel 617	0.29
Inconel	0.85 to 0.93
Incoloy 800	0.29
Kanthal	0.80 to 0.90
Stainless steel	0.30
Hastelloy X	0.3

Semi conductor	Emissivity
Silicon	0.69 to 0.71
Germanium	0.60
Gallium arsenic	0.68

Ceramics	Emissivity
Silicon carbide	0.80 to 0.83
Titanium carbide	0.47 to 0.50
Silicon nitride	0.89 to 0.90

Other	Emissivity
Carbon pigment	0.90 to 0.95
Graphite	0.87 to 0.92

13.3 Emissivity table ($\lambda = 1.55\mu\text{m}$)

Metal	Emissivity
Aluminum	0.09 to 0.40
Chrome	0.34 to 0.80
Cobalt	0.28 to 0.65
Copper	0.05 to 0.80
Gold	0.02
Steel plate	0.30 to 0.85
Lead	0.28 to 0.65
Magnesium	0.24 to 0.75
Molybdenum	0.25 to 0.80
Nickel	0.25 to 0.85
Palladium	0.23
Platinum	0.22
Rhodium	0.18
Silver	0.04 to 0.10
Tantalum	0.20 to 0.80
Tin	0.28 to 0.60
Titanium	0.50 to 0.80
Tungsten	0.30
Zinc	0.32 to 0.55

Alloy	Emissivity
Brass	0.18 to 0.70
Chromel, Alumel	0.30 to 0.80
Constantan, Manganin	0.22 to 0.60
Inconel	0.30 to 0.85
Monel	0.22 to 0.70
Nickel Chrome	0.28 to 0.85

Ceramics	Emissivity
Alumina ceramics	0.30
Red brick	0.80
White brick	0.35
Silicon brick	0.60
Sillimanite brick	0.60
Ceramics	0.50

Other	Emissivity
Asbestos	0.90
Asphalt	0.85
Carbon	0.85
Graphite	0.80
Soot	0.95
Cement, Concrete	0.70
Cloth	0.80

CHINO

CHINO CORPORATION

32-8, KUMANO-CHO, ITABASHI-KU, TOKYO 173-8632

Telephone: +81-3-3956-2171

Facsimile: +81-3-3956-0915

Web site <http://www.chino.co.jp/>

