

Operating Instructions

Cerabar M

Deltabar M

Deltapilot M

Process pressure / Differential pressure, Flow /
Hydrostatic



Cerabar M

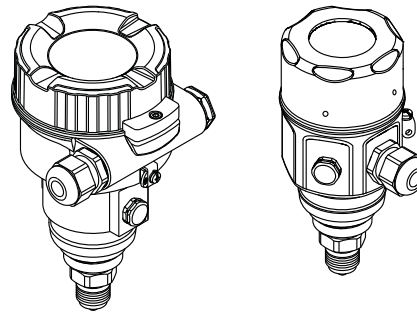

Deltabar M

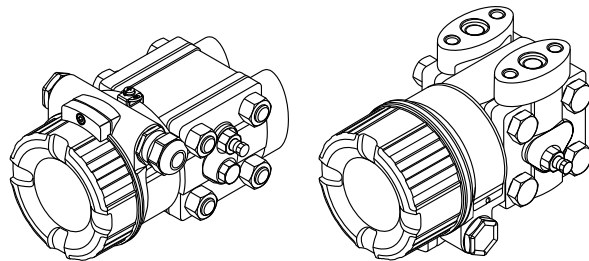

Deltapilot M

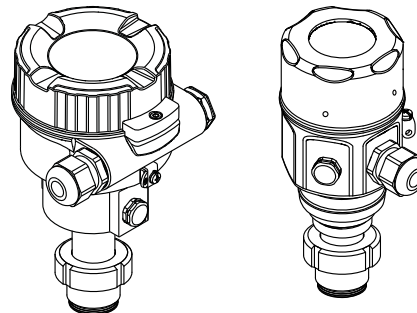

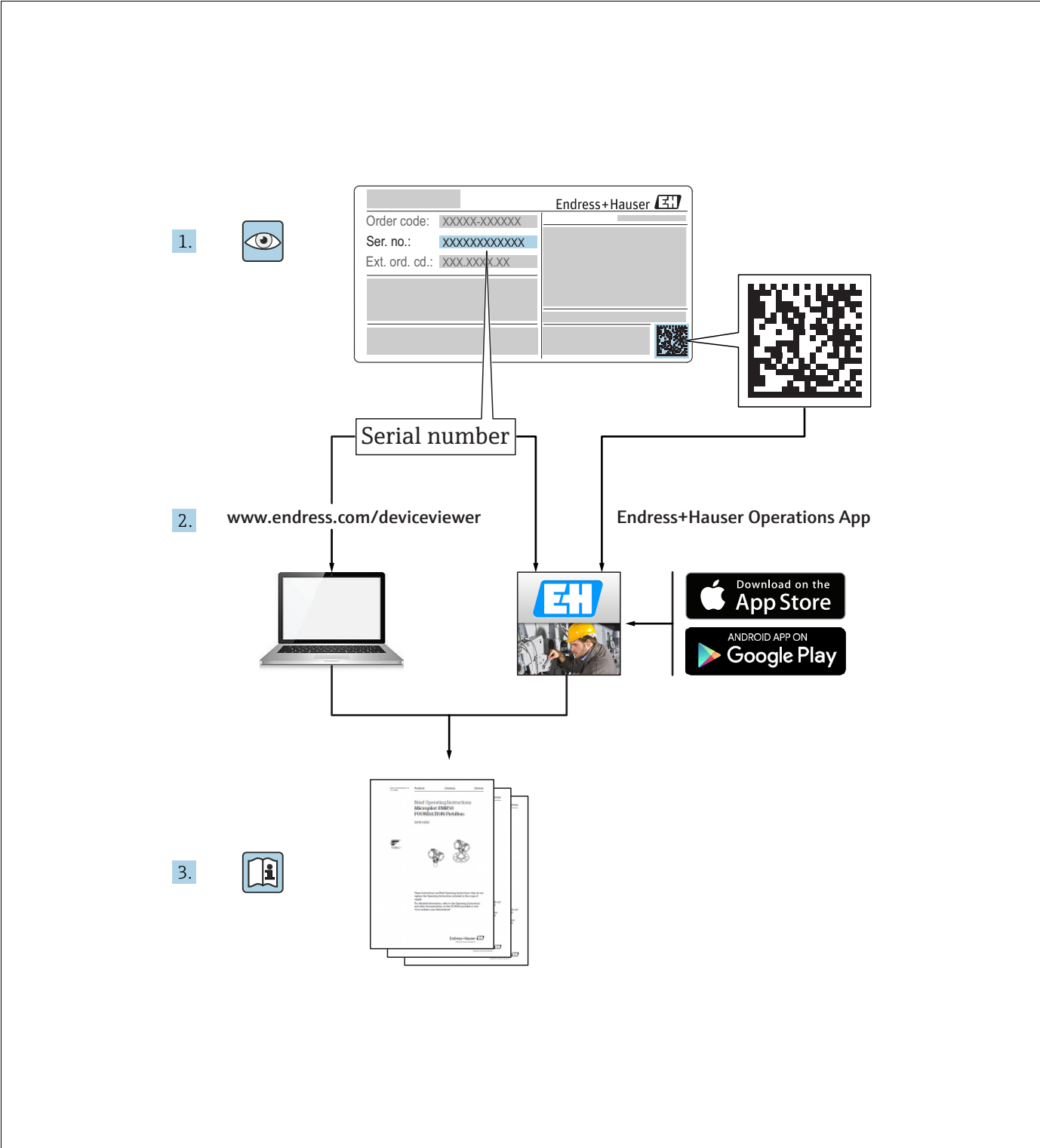

A0023555

Make sure the document is stored in a safe place such that it is always available when working on or with the device.

To avoid danger to individuals or the facility, read the "Basic safety instructions" section carefully, as well as all other safety instructions in the document that are specific to working procedures.

The manufacturer reserves the right to modify technical data without prior notice. Your Endress+Hauser distributor will supply you with current information and updates to these Instructions.

Table of contents

1	Document information	4	8	Commissioning with an operating menu (onsite display/FieldCare)	84
1.1	Document function	4	8.1	Function check	84
1.2	Symbols used	4	8.2	Commissioning	85
2	Basic safety instructions	7	8.3	Position zero adjustment	86
2.1	Requirements concerning the staff	7	8.4	Level measurement (Cerabar M and Deltapilot M) 87	
2.2	Designated use	7	8.5	Linearization	97
2.3	Workplace safety	7	8.6	Pressure measurement	101
2.4	Operational safety	7	8.7	Differential pressure measurement (Deltabar M) . 102	
2.5	Hazardous area	8	8.8	Flow measurement (Deltabar M)	104
2.6	Product safety	8	8.9	Level measurement (Deltabar M)	107
3	Identification	9	8.10	Overview of the onsite display operating menu ... 119	
3.1	Product identification	9	8.11	Description of parameters	127
3.2	Device designation	9	8.12	Saving or duplicating device data	148
3.3	Scope of delivery	12	9	Commissioning via Class 2 master (FieldCare)	149
3.4	CE mark, Declaration of Conformity	12	9.1	Function check	149
4	Installation	13	9.2	Commissioning	150
4.1	Incoming acceptance	13	9.3	Output value (Out Value)	151
4.2	Storage and transport	13	9.4	Electrical differential pressure measurement with gauge pressure sensors (Cerabar M or Deltapilot M) 153	
4.3	Installation conditions	13	9.5	Description of parameters	155
4.4	General installation instructions	14	9.6	Saving or duplicating device data	202
4.5	Installing Cerabar M	15	10	Maintenance	203
4.6	Installing Deltabar M	25	10.1	Cleaning instructions	203
4.7	Installing Deltapilot M	33	10.2	Exterior cleaning	203
4.8	Installing profile seal for universal process adapter 38		11	Troubleshooting	204
4.9	Closing the housing cover	38	11.1	Messages	204
4.10	Post-installation check	38	11.2	Response of outputs to errors	207
5	Electrical connection	39	11.3	Repair	208
5.1	Connecting the device	39	11.4	Repair of Ex-certified devices	208
5.2	Connecting the measuring unit	40	11.5	Spare Parts	209
5.3	Potential equalization	41	11.6	Return	209
5.4	Overvoltage protection (optional)	42	11.7	Disposal	209
5.5	Post-connection check	44	11.8	Software history	209
6	Operation	45	12	Technical data	210
6.1	Operating options	45		Index	211
6.2	Operation without an operating menu	46			
6.3	Operation with an operating menu	48			
6.4	PROFIBUS PA communication protocol	57			
7	Commissioning without an operating menu	82			
7.1	Function check	82			
7.2	Position adjustment	82			





1 Document information

1.1 Document function







These Operating Instructions contain all the information that is required in various phases of the life cycle of the device: from product identification, incoming acceptance and storage, to mounting, connection, operation and commissioning through to troubleshooting, maintenance and disposal.

1.2 Symbols used



1.2.1 Safety symbols

Symbol	Meaning
 A0011189-DE	DANGER! This symbol alerts you to a dangerous situation. Failure to avoid this situation will result in serious or fatal injury.
 A0011190-DE	WARNING! This symbol alerts you to a dangerous situation. Failure to avoid this situation can result in serious or fatal injury.
 A0011191-DE	CAUTION! This symbol alerts you to a dangerous situation. Failure to avoid this situation can result in minor or medium injury.
 A0011192-DE	NOTICE! This symbol contains information on procedures and other facts which do not result in personal injury.











1.2.2 Electrical symbols

Symbol	Meaning	Symbol	Meaning
	Direct current		Alternating current
	Direct current and alternating current		Ground connection A grounded terminal which, as far as the operator is concerned, is grounded via a grounding system.
	Protective ground connection A terminal which must be connected to ground prior to establishing any other connections.		Equipotential connection A connection that has to be connected to the plant grounding system: This may be a potential equalization line or a star grounding system depending on national or company codes of practice.

1.2.3 Tool symbols

Symbol	Meaning
 A0011221	Allen key
 A0011222	Hexagon wrench

1.2.4 Symbols for certain types of information

Symbol	Meaning
 A0011182	Permitted Indicates procedures, processes or actions that are permitted.
 A0011184	Forbidden Indicates procedures, processes or actions that are forbidden.
 A0011193	Tip Indicates additional information.
 A0015482	Reference to documentation
 A0015484	Reference to page
 A0015487	Reference to graphic
1. , 2. , ...	Series of steps
 A0018343	Result of a sequence of actions
 A0015502	Visual inspection
 A0015502	Indicates how to navigate to the parameter using the display and operating module
 A0015502	Indicates how to navigate to the parameter using operating tools (e.g. FieldCare)

1.2.5 Symbols in graphics

Symbol	Meaning
1, 2, 3, 4, ...	Item numbers
1. , 2. , ...	Series of steps
A, B, C, D, ...	Views

1.2.6 Symbols at the device

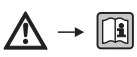
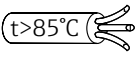
Symbol	Meaning
 A0019159	Safety instructions Observe the safety instructions contained in the associated Operating Instructions.
	Connecting cable immunity to temperature change Indicates that the connecting cables have to withstand a temperature of 85°C at least.

1.2.7 Registered trademarks

KALREZ[®], VITON[®], TEFLON[®]

Registered label of E.I. Du Pont de Nemours & Co., Wilmington, USA

TRI-CLAMP[®]

Registered label of Ladish & Co., Inc., Kenosha, USA

PROFIBUS PA[®]

Trademark of the PROFIBUS User Organization, Karlsruhe, Germany

GORE-TEX[®]

Registered label of W.L. Gore & Associates, Inc., USA

2 Basic safety instructions

2.1 Requirements concerning the staff

The personnel for installation, commissioning, diagnostics and maintenance must fulfill the following requirements:

- Trained, qualified specialists: must have a relevant qualification for this specific function and task
- Are authorized by the plant owner/operator
- Are familiar with federal/national regulations
- Before beginning work, the specialist staff must have read and understood the instructions in the Operating Instructions and supplementary documentation as well as in the certificates (depending on the application)
- Following instructions and basic conditions

The operating personnel must fulfill the following requirements:

- Being instructed and authorized according to the requirements of the task by the facility's owner-operator
- Following the instructions in these Operating Instructions

2.2 Designated use

The **Cerabar M** is a pressure transmitter for measuring level and pressure.

The **Deltabar M** is a differential pressure transmitter for measuring differential pressure, flow and level.

The **Deltapilot M** is a hydrostatic pressure sensor for measuring level and pressure.

2.2.1 Incorrect use

The manufacturer is not liable for damage caused by improper or non-designated use.

Verification for borderline cases:

For special fluids and fluids for cleaning, Endress+Hauser is glad to provide assistance in verifying the corrosion resistance of fluid-wetted materials, but does not accept any warranty or liability.

2.3 Workplace safety

For work on and with the device:

- Wear the required personal protective equipment according to federal/national regulations.
- Switch off the supply voltage before connecting the device.

2.4 Operational safety

Risk of injury!

- ▶ Operate the device in proper technical condition and fail-safe condition only.
- ▶ The operator is responsible for interference-free operation of the device.
- ▶ Only disassemble the device in pressurless condition!

Conversions to the device

Unauthorized modifications to the device are not permitted and can lead to unforeseeable dangers:

- ▶ If, despite this, modifications are required, consult with Endress+Hauser.

Repair

To ensure continued operational safety and reliability,

- ▶ Carry out repairs on the device only if they are expressly permitted.
- ▶ Observe federal/national regulations pertaining to repair of an electrical device.
- ▶ Use original spare parts and accessories from Endress+Hauser only.

2.5 Hazardous area

To eliminate a danger for persons or for the facility when the device is used in the hazardous area (e.g. explosion protection, pressure vessel safety):

- Based on the nameplate, check whether the ordered device is permitted for the intended use in the hazardous area.
- Observe the specifications in the separate supplementary documentation that is an integral part of these Instructions.

2.6 Product safety

This measuring device is designed in accordance with good engineering practice to meet state-of-the-art safety requirements, has been tested, and left the factory in a condition in which they are safe to operate. It fulfills general safety requirements and legal requirements. It also conforms to the EC directives listed in the device-specific EC declaration of conformity. Endress+Hauser confirms this fact by applying the CE mark.

3 Identification

3.1 Product identification

The following options are available for identification of the measuring device:

- Nameplate specifications
- Order code with breakdown of the device features on the delivery note
- Enter serial numbers from nameplates in W@M Device Viewer (www.endress.com/deviceviewer): All information about the measuring device is displayed.

For an overview of the technical documentation provided, enter the serial number from the nameplates in the W@M Device Viewer (www.endress.com/deviceviewer).

3.2 Device designation

3.2.1 Nameplate

- The MWP (maximum working pressure) is specified on the nameplate. This value refers to a reference temperature of 20°C (68°F) or 100°F (38°C) for ANSI flanges.
- The pressure values permitted at higher temperatures can be found in the following standards:
 - EN 1092-1: 2001 Tab. 18 ¹⁾
 - ASME B 16.5a – 1998 Tab. 2-2.2 F316
 - ASME B 16.5a – 1998 Tab. 2.3.8 N10276
 - JIS B 2220
- The test pressure corresponds to the over pressure limit (OPL) of the device = MWP x 1.5 ²⁾.
- The Pressure Equipment Directive (EC Directive 97/23/EC) uses the abbreviation "PS". The abbreviation "PS" corresponds to the MWP (maximum working pressure) of the measuring device.

- 1) With regard to their stability-temperature property, the materials 1.4435 and 1.4404 are grouped together under 13EO in EN 1092-1 Tab. 18. The chemical composition of the two materials can be identical.
- 2) The equation does not apply for PMP51 and PMP55 with a 40 bar (600 psi) or a 100 bar (1500 psi) measuring cell.

Aluminum housing

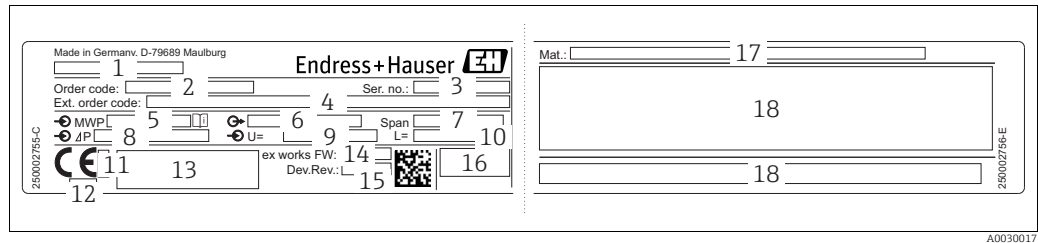

Fig. 1: Nameplate

- 1 Device name
- 2 Order code (for re-orders)
- 3 Serial number (for identification)
- 4 Extended order code (complete)
- 5 MWP (maximum working pressure)
- 6 Electronic version (output signal)
- 7 Min./max. span
- 8 Nominal measuring range
- 9 Supply voltage
- 10 Unit of length
- 11 ID number of notified body with regard to ATEX (optional)
- 12 ID number of notified body with regard to Pressure Equipment Directive (optional)
- 13 Approvals
- 14 Device version
- 15 Software version
- 16 Degree of protection
- 17 Wetted materials
- 18 Approval-specific information

Devices suitable for oxygen applications are fitted with an additional nameplate.

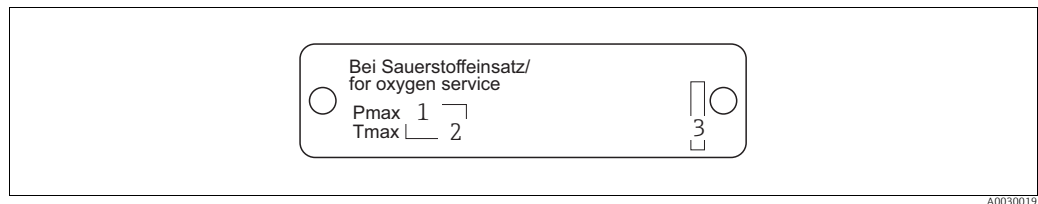

Fig. 2: Additional nameplate for devices suitable for oxygen applications

- 1 Maximum pressure for oxygen applications
- 2 Maximum temperature for oxygen applications
- 3 Layout identification of the nameplate

Stainless steel housing, hygienic

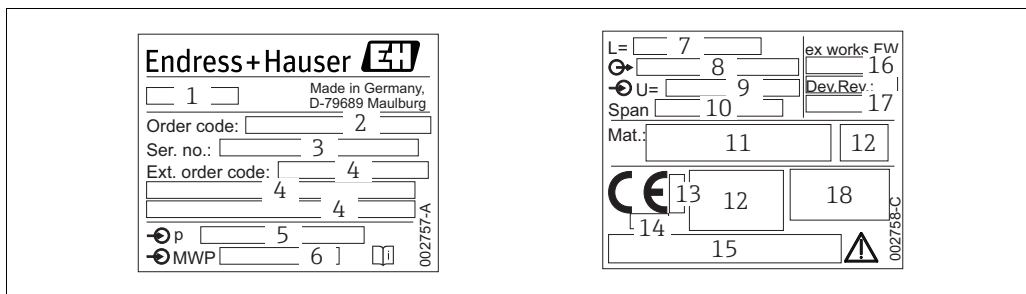

Fig. 3: Nameplate for Cerabar M and Deltapilot M

- 1 Device name
- 2 Order code (for re-orders)
- 3 Serial number (for identification)
- 4 Extended order code (complete)
- 5 Nominal measuring range
- 6 MWP (maximum working pressure)
- 7 Length data
- 8 Electronic version (output signal)
- 9 Supply voltage
- 10 Min./max. span
- 11 Wetted materials
- 12 Approval-specific information
- 13 ID number of notified body with regard to ATEX (optional)
- 14 ID number of notified body with regard to Pressure Equipment Directive (optional)
- 15 Approvals
- 16 Software version
- 17 Device version
- 18 Degree of protection

Devices with certificates are fitted with an additional plate.

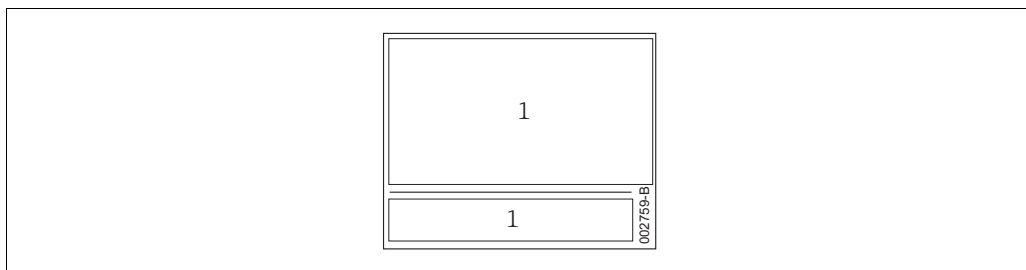

Fig. 4: Additional nameplate for devices with certificates

- 1 Approval-specific information

3.2.2 Identifying the sensor type

In the case of gauge pressure sensors, the "Pos. zero adjust" parameter appears in the operating menu ("Setup" -> "Pos. zero adjust").
 In the case of absolute pressure sensors, the "Calib. offset" parameter appears in the operating menu ("Setup" -> "Calib. offset").

3.3 Scope of delivery

The scope of delivery comprises:

- Device
- Optional accessories

Documentation supplied:

- The Operating Instructions BA00383P is available on the Internet.
→ See: www.endress.com → Download
- Brief Operating Instructions: KA01031P Cerabar M / KA01028P Deltabar M / KA01034P Deltapilot M
- Final inspection report
- Additional Safety Instructions for ATEX, IECEx and NEPSI devices
- Optional: factory calibration form, test certificates

3.4 CE mark, Declaration of Conformity

The devices are designed to meet state-of-the-art safety requirements, have been tested and left the factory in a condition in which they are safe to operate. The devices comply with the applicable standards and regulations as listed in the EC Declaration of Conformity and thus comply with the statutory requirements of the EC Directives. Endress+Hauser confirms the conformity of the device by affixing to it the CE mark.

4 Installation

4.1 Incoming acceptance

- Check the packaging and the contents for damage.
- Check the shipment, make sure nothing is missing and that the scope of supply matches your order.

4.2 Storage and transport

4.2.1 Storage

The device must be stored in a dry, clean area and protected against damage from impact (EN 837-2).

Storage temperature range:

See Technical Information for Cerabar M TI00436P / Deltabar M TI00434P / Deltapilot M TI00437P.

4.2.2 Transport

▲ WARNING

Incorrect transportation

Housing, diaphragm and capillaries may become damaged, and there is a risk of injury!

- ▶ Transport the measuring device to the measuring point in its original packaging or by the process connection.
- ▶ Follow the safety instructions and transport conditions for devices weighing more than 18 kg (39.6 lbs).
- ▶ Do not use capillaries as a carrying aid for the diaphragm seals.

4.3 Installation conditions

4.3.1 Dimensions

→ For dimensions, please refer to the Technical Information for Cerabar M TI00436P / Deltabar M TI00434P / Deltapilot M TI00437P, "Mechanical construction" section.

4.4 General installation instructions

- Devices with a G 1 1/2 thread:
When screwing the device into the tank, the flat seal has to be positioned on the sealing surface of the process connection. To avoid additional strain on the process isolating diaphragm, the thread should never be sealed with hemp or similar materials.
- Devices with NPT threads:
 - Wrap Teflon tape around the thread to seal it.
 - Tighten the device at the hexagonal bolt only. Do not turn at the housing.
 - Do not overtighten the thread when screwing. Max. torque: 20 to 30 Nm (14.75 to 22.13 lbf ft)

4.4.1 Mounting sensor modules with PVDF thread

⚠ WARNING

Risk of damage to process connection!

Risk of injury!

- ▶ Sensor modules with PVDF process connections with threaded connection must be installed with the mounting bracket provided!

⚠ WARNING

Material fatigue from pressure and temperature!

Risk of injury if parts burst! The thread can become loose if exposed to high pressure and temperatures.

- ▶ The integrity of the thread must be checked regularly and the thread may need to be re-tightened with the maximum tightening torque of 7 Nm (5.16 lbf ft). Teflon tape is recommended for sealing the 1/2" NPT thread.

4.5 Installing Cerabar M

- Due to the orientation of the Cerabar M, there may be a shift in the zero point, i.e. when the container is empty or partially full, the measured value does not display zero. You can correct this zero point shift → § 47, → Chap. "Function of the operating elements" or → § 86, → Chap. 8.3 "Position zero adjustment".
- For PMP55, please refer to Section 4.5.2 "Installation instructions for devices with diaphragm seals – PMP55", → § 18.
- Endress+Hauser offers a mounting bracket for installing on pipes or walls. → § 22, → Chap. 4.5.5 "Wall and pipe mounting (optional)".

4.5.1 Installation instructions for devices without diaphragm seals – PMP51, PMC51

NOTICE

Damage to the device!

If a heated Cerabar M is cooled during the cleaning process (e.g. by cold water), a vacuum develops for a short time, whereby moisture can penetrate the sensor through the pressure compensation (1).

- ▶ If this is the case, mount the Cerabar M with the pressure compensation (1) pointing downwards.

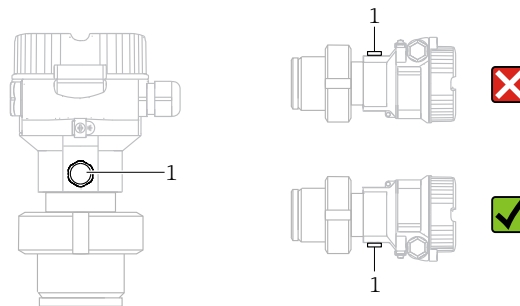

- Keep the pressure compensation and GORE-TEX® filter (1) free from contamination.
- Cerabar M transmitters without diaphragm seals are mounted as per the norms for a manometer (DIN EN 837-2). We recommend the use of shutoff devices and siphons. The orientation depends on the measuring application.
- Do not clean or touch process isolating diaphragms with hard or pointed objects.
- The device must be installed as follows in order to comply with the cleanability requirements of the ASME-BPE (Part SD Cleanability):

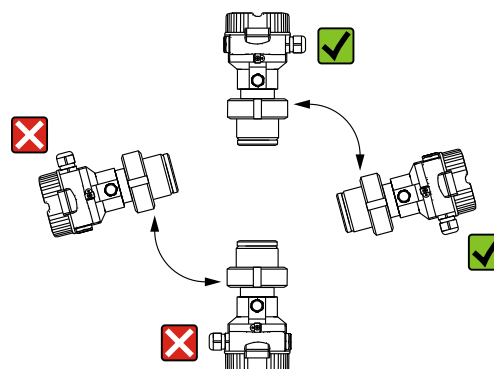

Pressure measurement in gases

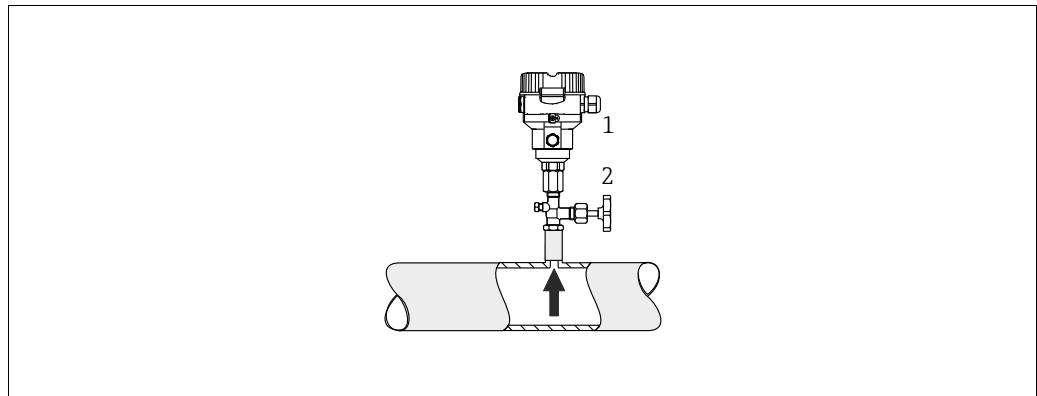

Fig. 5: Measuring arrangement for pressure measurement in gases

- 1 Cerabar M
- 2 Shutoff device

Mount the Cerabar M with the shutoff device above the tapping point so that any condensate can flow into the process.

Pressure measurement in steams

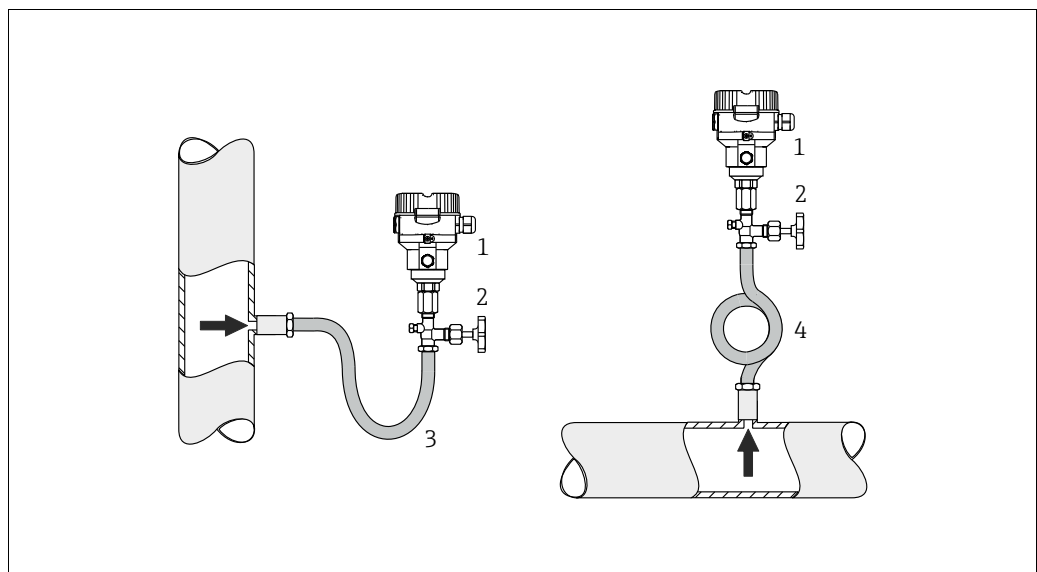

Fig. 6: Measuring arrangement for pressure measurement in steams

- 1 Cerabar M
- 2 Shutoff device
- 3 U-shaped siphon
- 4 Circular siphon

- Mount Cerabar M with siphon above the tapping point.
- Fill the siphon with liquid before commissioning.
The siphon reduces the temperature to almost the ambient temperature.

Pressure measurement in liquids

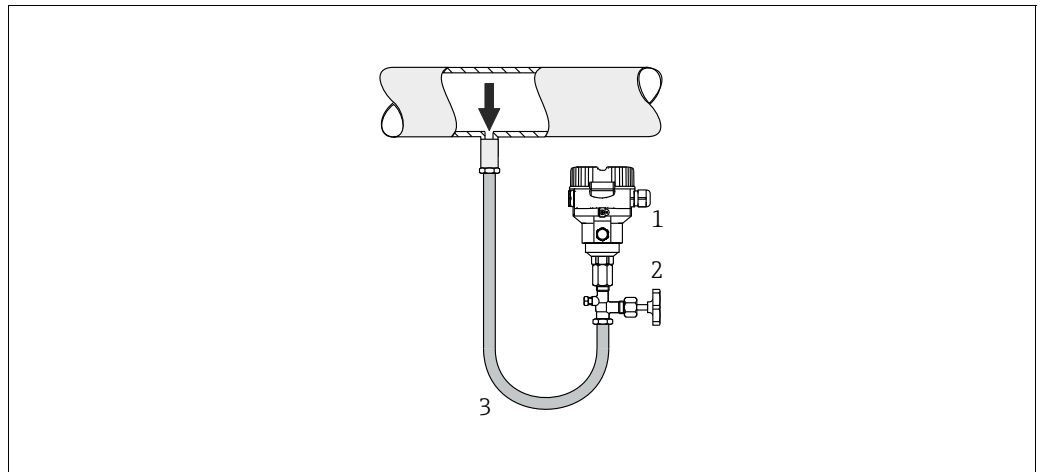

Fig. 7: Measuring arrangement for pressure measurement in liquids

- 1 Cerabar M
- 2 Shutoff device

- Mount Cerabar M with shutoff device below or at the same level as the tapping point.

Level measurement

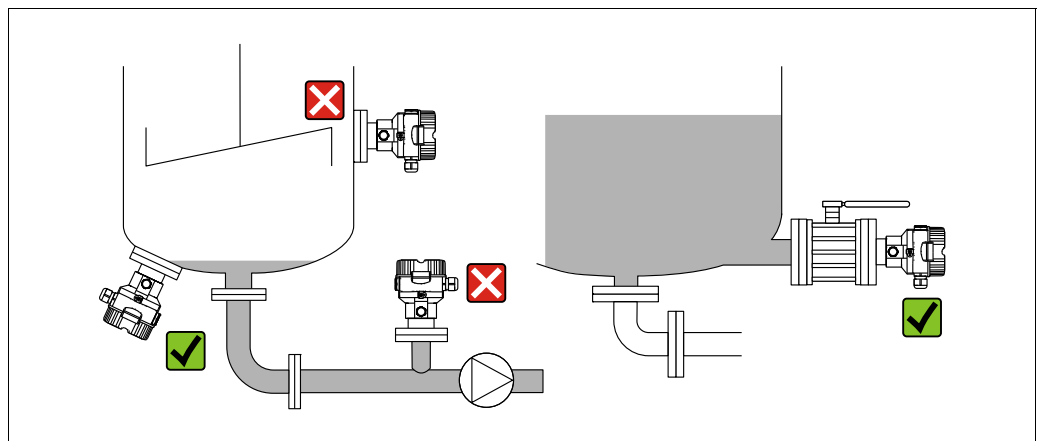

Fig. 8: Measuring arrangement for level

- Always install the Cerabar M below the lowest measuring point.
- Do not mount the device in the filling curtain or at a point in the tank which could be affected by pressure pulses from an agitator.
- Do not mount the device in the suction area of a pump.
- The calibration and functional test can be carried out more easily if you mount the device downstream of a shutoff device.

4.5.2 Installation instructions for devices with diaphragm seals – PMP55

- Cerabar M devices with diaphragm seals are screwed in, flanged or clamped, depending on the type of diaphragm seal.
- Please note that the hydrostatic pressure of the liquid columns in the capillaries can cause zero point shift. The zero point shift can be corrected.
- Do not clean or touch the process isolating diaphragm of the diaphragm seal with hard or pointed objects.
- Do not remove process isolating diaphragm protection until shortly before installation.

NOTICE

Improper handling!

Damage to the device!

- ▶ A diaphragm seal and the pressure transmitter together form a closed, oil-filled calibrated system. The fill fluid hole is sealed and may not be opened.
- ▶ When using a mounting bracket, sufficient strain relief must be ensured for the capillaries in order to prevent the capillary bending down (bending radius ≥ 100 (3.94 in)).
- ▶ Please observe the application limits of the diaphragm seal filling oil as detailed in the Technical Information for Cerabar M TI00436P, "Planning instructions for diaphragm seal systems" section.

NOTICE

In order to obtain more precise measurement results and to avoid a defect in the device, mount the capillaries as follows:

- ▶ Vibration-free (in order to avoid additional pressure fluctuations)
- ▶ Not in the vicinity of heating or cooling lines
- ▶ Insulate if the ambient temperature is below or above the reference temperature
- ▶ With a bending radius of ≥ 100 mm (3.94 in).
- ▶ Do not use the capillaries as a carrying aid for the diaphragm seals!

Vacuum application

For applications under vacuum, Endress+Hauser recommends mounting the pressure transmitter below the diaphragm seal. This prevents vacuum loading of the diaphragm seal caused by the presence of fill fluid in the capillary.

When the pressure transmitter is mounted above the diaphragm seal, the maximum height difference H1 in accordance with the illustrations below must not be exceeded.

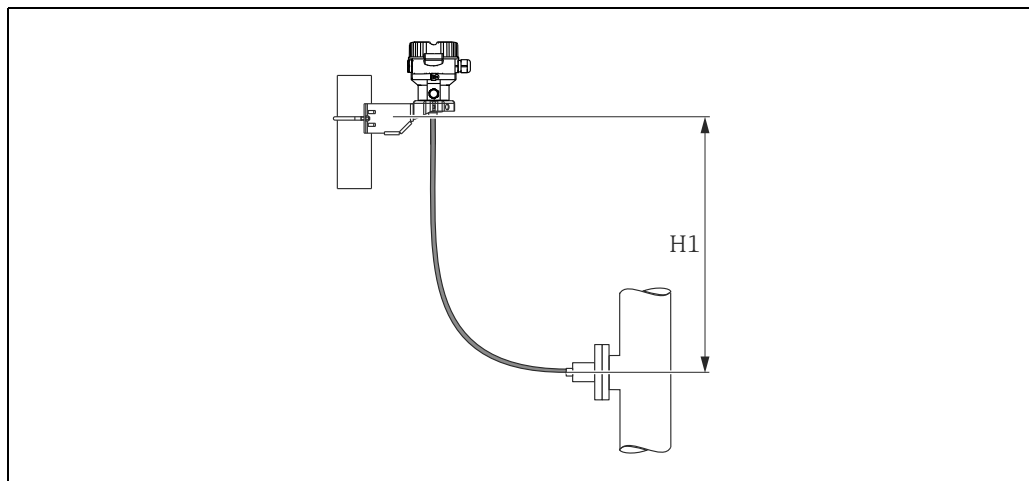

Fig. 9: Installation above the lower diaphragm seal

The maximum height difference depends on the density of the filling oil and the smallest ever pressure that is permitted to occur at the diaphragm seal (empty vessel), see illustration below:

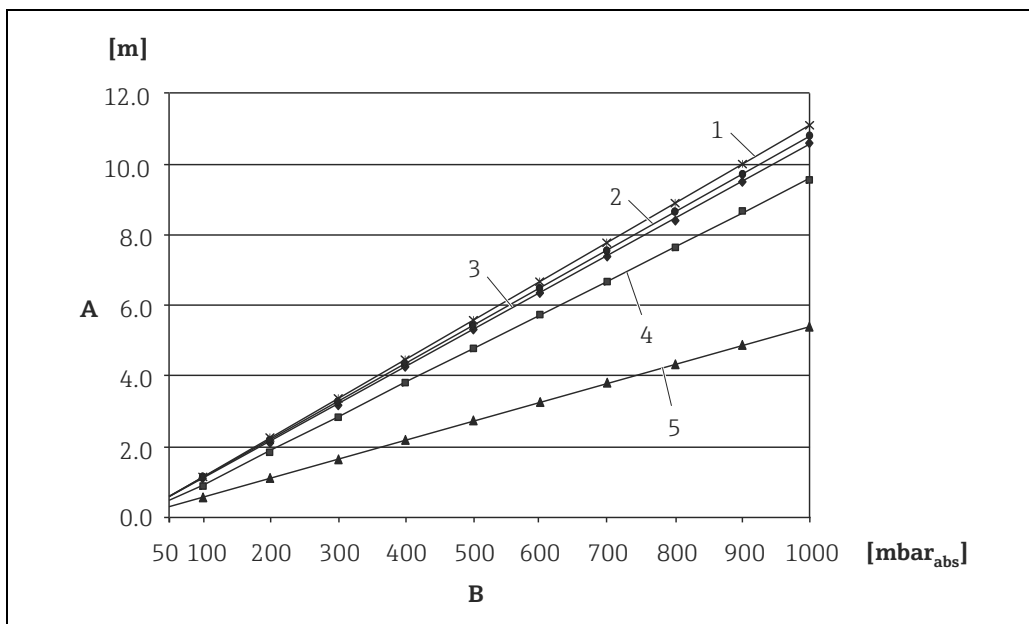

Fig. 10: Diagram of maximum installation height above the lower diaphragm seal for vacuum applications depending on the pressure at the diaphragm seal on the positive side

- A Height difference H1
- B Pressure at diaphragm seal
- 1 Low temperature oil
- 2 Vegetable oil
- 3 Silicone oil
- 4 High-temperature oil
- 5 Inert oil

Mounting with temperature isolator

Endress+Hauser recommends the use of temperature isolators in the event of constant extreme medium temperatures which lead to the maximum permissible electronics temperature of +85 °C (+185 °F) being exceeded.

Depending on the filling oil used, diaphragm seal systems with temperature isolators can be used for maximum temperatures of up to 400 °C (+752 °F). → For the temperature application limits, see technical Information, "Diaphragm seal filling oils" section.

To minimize the influence of rising heat, Endress+Hauser recommends the device be mounted horizontally or with the housing pointing downwards. The additional installation height also brings about a maximum zero point shift of 21 mbar (0.315 psi) due to the hydrostatic column in the temperature isolator. You can correct this zero point shift at the device.

The temperature restrictions are lowest with an insulation height of 30 mm (1.18 inch).

Full insulation exhibits virtually the same behavior as no insulation!

The temperature limits with an insulation height of 30 mm (1.18 inch) are illustrated in the following graphic.

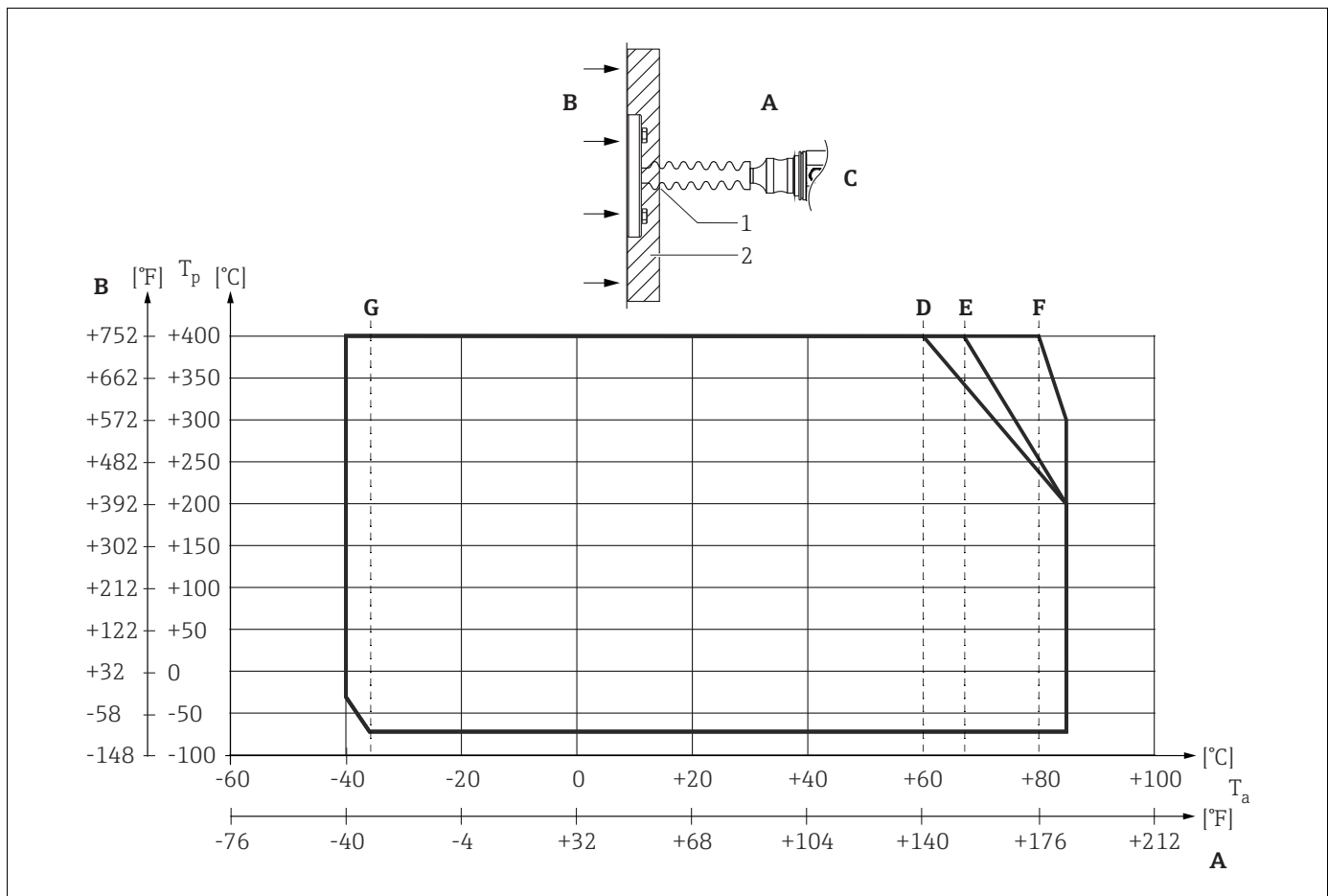

Fig. 11:

- A Ambient temperature: ≤ 85 °C (185 °F)
- B Process temperature: max. 400 °C (752 °F), depending on the filling oil used
- C Device with temperature isolator, material 316L (1.4404)
- D Without isolation
- E Maximum isolation
- F 30 mm (1.18. inch) isolation
- G Without isolation, maximum isolation, 30 mm (1.18. inch) isolation
- 1 Isolation height 30 mm (1.18. inch)
- 2 Isolation material

4.5.3 Seal for flange mounting

NOTICE

Corrupted measurement results.

The seal is not allowed to press against the process isolating diaphragm as this could affect the measurement result.

- ▶ Ensure that the seal is not touching the process isolating diaphragm.

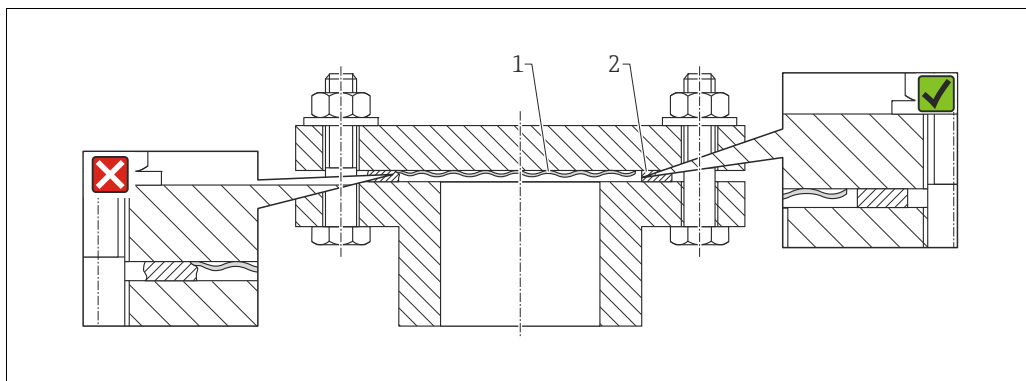

Fig. 12:
 1 Process isolating diaphragm
 2 Seal

4.5.4 Thermal insulation – PMP55

The PMP55 may only be insulated up to a certain height. The maximum permitted insulation height is indicated on the devices and applies to an insulation material with a heat conductivity $\leq 0.04 \text{ W/(m x K)}$ and to the maximum permitted ambient and process temperature. The data were determined under the most critical application "quiescent air".

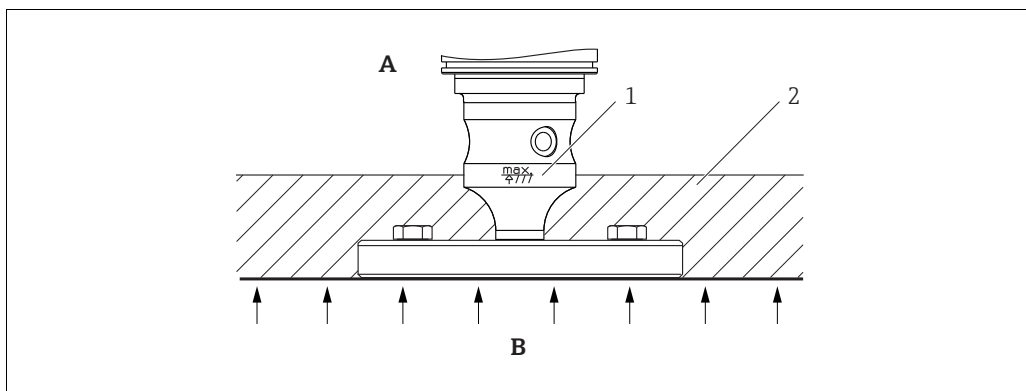
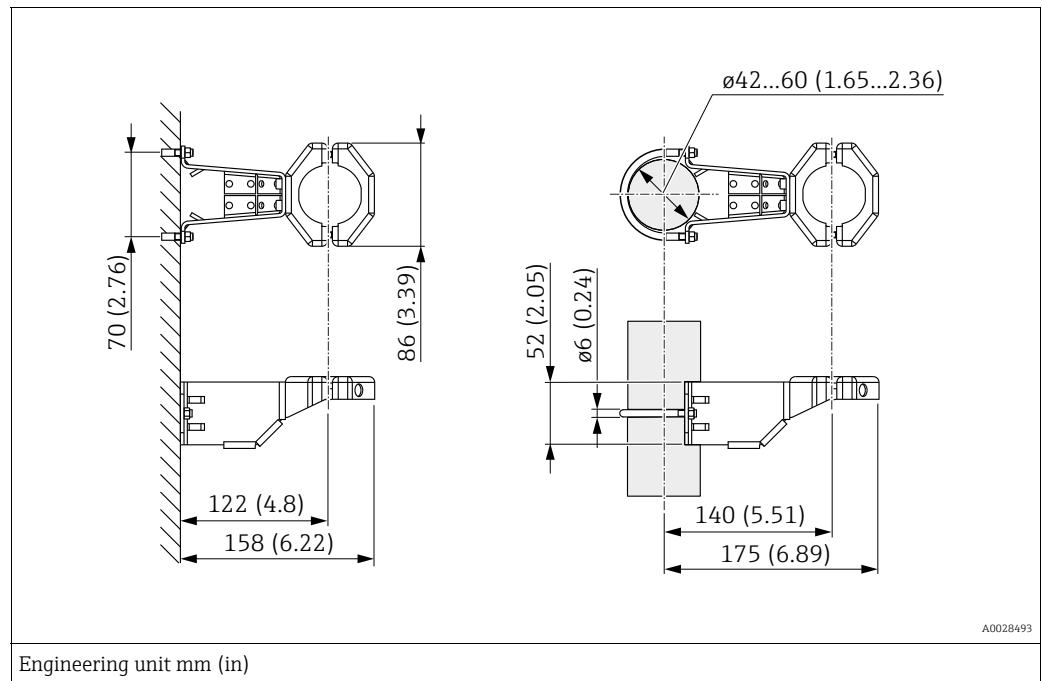

Fig. 13: Maximum permitted insulation height, here indicated on a PMP55 with a flange

- A Ambient temperature: $\leq 70 \text{ }^\circ\text{C}$ (158°F)
- B Process temperature: max. $400 \text{ }^\circ\text{C}$ (752°F), depending on the diaphragm seal filling oil used
- 1 Maximum permitted insulation height
- 2 Insulation material

4.5.5 Wall and pipe mounting (optional)

Endress+Hauser offers a mounting bracket for installation on pipes or walls (for pipe diameters from 1 ¼" to 2").



Please note the following when mounting:

- Devices with capillary tubes: mount capillaries with a bending radius ≥ 100 mm (3.94 in).
- When mounting on a pipe, tighten the nuts on the bracket uniformly with a torque of at least 5 Nm (3.69 lbs ft).

4.5.6 Assembling and mounting the "separate housing" version

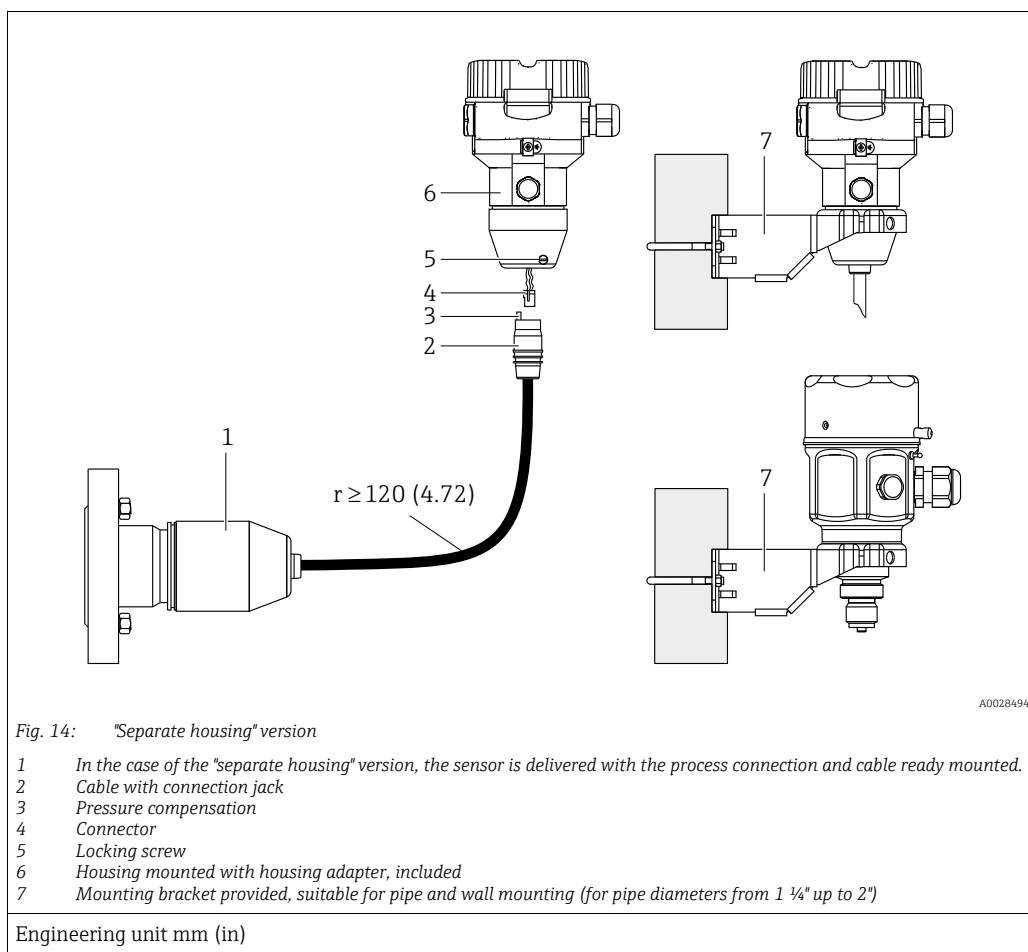

Assembly and mounting

1. Insert the connector (item 4) into the corresponding connection jack of the cable (item 2).
2. Plug the cable into the housing adapter (item 6).
3. Tighten the locking screw (item 5).
4. Mount the housing on a wall or pipe using the mounting bracket (item 7).
 When mounting on a pipe, tighten the nuts on the bracket uniformly with a torque of at least 5 Nm (3.69 lbs ft).
 Mount the cable with a bending radius (r) ≥ 120 mm (4.72 in).

Routing the cable (e.g. through a pipe)

You require the cable shortening kit.

Order number: 71093286

For details on mounting, see SD00553P/00/A6.

4.5.7 PMP51, version prepared for diaphragm seal mount – welding recommendation

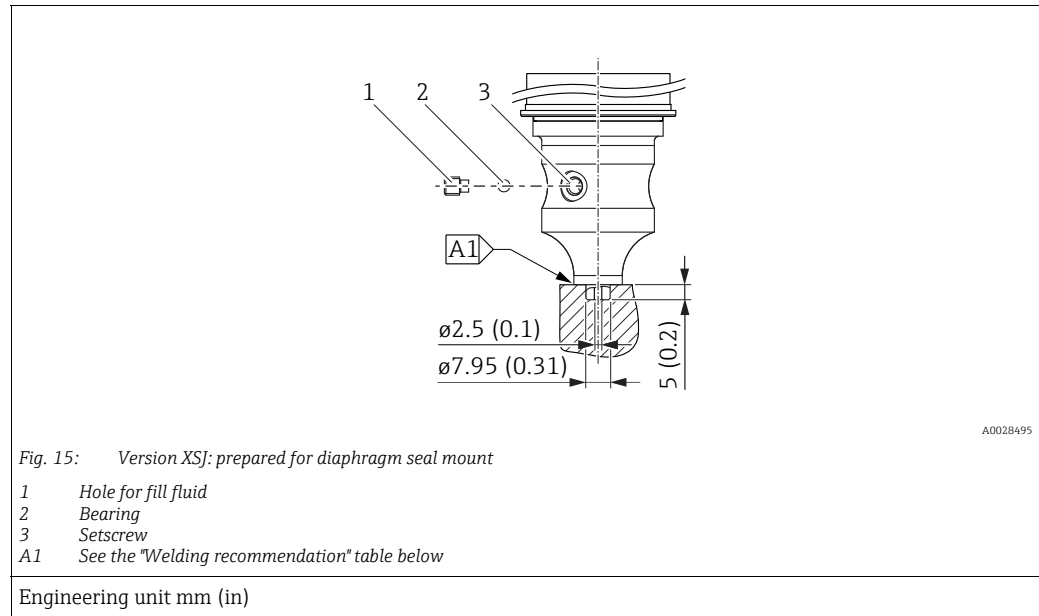

Endress+Hauser recommends welding on the diaphragm seal as follows for the "Version XSJ: prepared for diaphragm seal mount" version in feature 110 "Process connection" in the order code up to, and including, 40 bar (600 psi) sensors: the total welding depth of the fillet weld is 1 mm (0.04 in) with an outer diameter of 16 mm (0.63 in). Welding is performed according to the WIG method.

Consecutive seam no.	Sketch/welding groove shape, dimension as per DIN 8551	Base material matching	Welding method DIN EN ISO 24063	Welding position	Inert gas, additives
A1 for sensors ≤ 40 bar (600 psi)	<p>A0024811</p>	Adapter made of AISI 316L (1.4435) to be welded to diaphragm seal made of AISI 316L (1.4435 or 1.4404)	141	PB	Inert gas Ar/H 95/5 Additive: ER 316L Si (1.4430)

Information on filling

The diaphragm seal must be filled as soon as it has been welded on.

- After welded into the process connection, the sensor assembly must be properly filled with a filling oil and sealed gas-tight with a sealing ball and lock screw. Once the diaphragm seal has been filled, at the zero point the device display should not exceed 10% of the full scale value of the cell measuring range. The internal pressure of the diaphragm seal must be corrected accordingly.
- Adjustment / calibration:
 - The device is operational once it has been fully assembled.
 - Perform a reset. The device must then be calibrated to the process measuring range as described in the Operating Instructions.

4.6 Installing Deltabar M

NOTICE

Incorrect handling!

Damage of the device!

- ▶ Disassembly of the screws with item number (1) is not permissible under any circumstances and will result in loss of warranty.

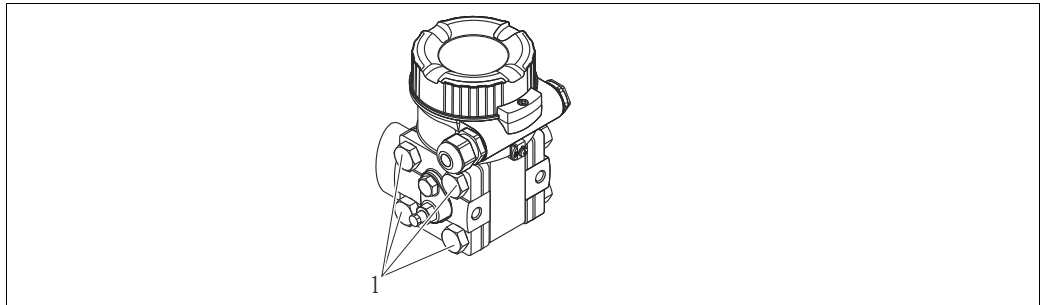

4.6.1 Installation position

- Due to the orientation of the Deltabar M, there may be a shift in the measured value, i.e. when the container is empty, the measured value does not display zero. You may correct this zero point shift by a position adjustment in one of the following ways:
 - via the operation keys on the electronics module (→ 47, "Function of the operating elements")
 - via the operating menu (→ 86, "Position zero adjustment")
- General recommendations for routing the impulse piping can be found in DIN 19210 "Methods for measurement of fluid flow; differential piping for flow measurement devices" or the corresponding national or international standards.
- Using a three-valve or five-valve manifold allows for easy commissioning, installation and maintenance without interrupting the process.
- When routing the impulse piping outdoors, ensure that sufficient anti-freeze protection is used, e.g. by using pipe heat tracing.
- Install the impulse piping with a monotonic gradient of at least 10%.
- Endress+Hauser offers a mounting bracket for installing on pipes or walls (→ 30, "Wall and pipe-mounting (option)").

Installation position for flow measurement



For more information about differential pressure flow measurement refer to following documents:

- Differential pressure flow measurements with orifices: Technical Information TI00422P
- Differential pressure flow measurement with Pitot tubes: Technical Information TI00425P

Flow measurement in gases

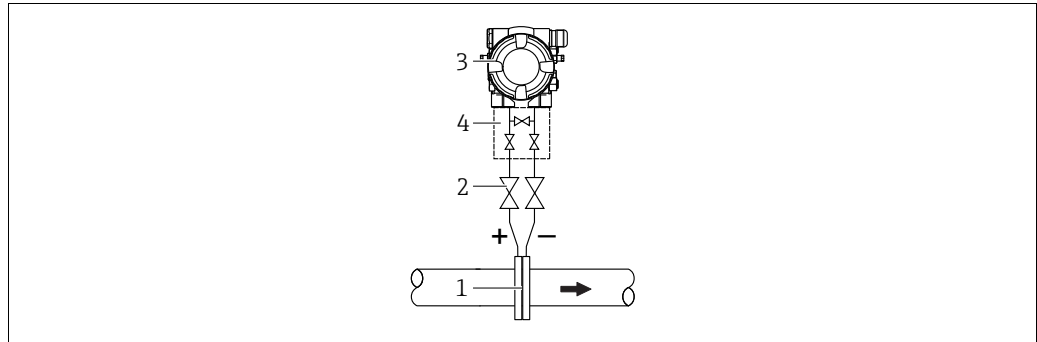

A0029783

Measuring layout for flow measurement in gases

- 1 Orifice plate or pitot tube
- 2 Shut-off valves
- 3 Deltabar M
- 4 Three-valve manifold

- Mount the Deltabar M above the measuring point so that the condensate which may be present, can run off into the process piping.

Flow measurement in steam

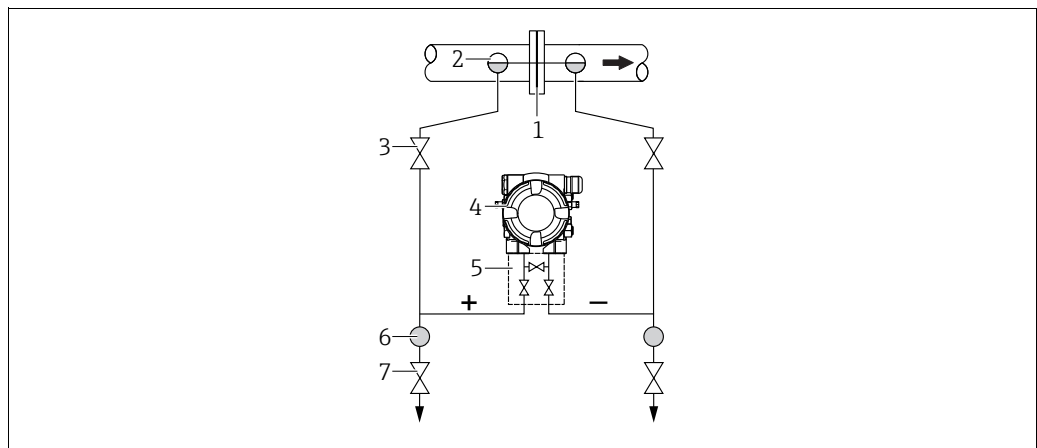

A0029784

Measuring layout for flow measurement in steam

- 1 Orifice plate or pitot tube
- 2 Condensate traps
- 3 Shut-off valves
- 4 Deltabar M
- 5 Three-valve manifold
- 6 Separator
- 7 Drain valves

- Mount the Deltabar M below the measuring point.
- Mount the condensate traps at the same level as the tapping points and at the same distance to the Deltabar M.
- Prior to commissioning, fill the impulse piping to the height of the condensate traps.

Flow measurement in liquids

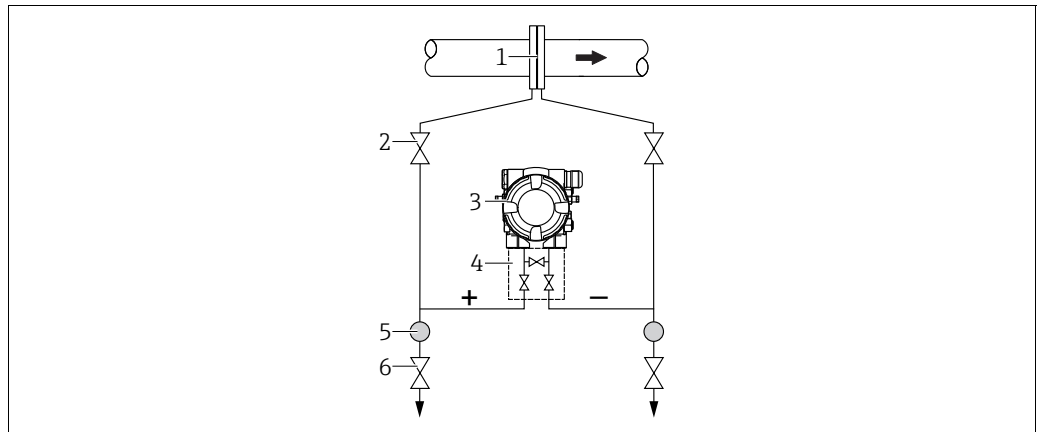

A0029785

Measuring layout for flow measurement in liquids

- 1 Orifice plate or pitot tube
- 2 Shut-off valves
- 3 Deltabar M
- 4 Three-valve manifold
- 5 Separator
- 6 Drain valves

- Mount the Deltabar M below the measuring point so that the impulse piping is always filled with liquid and gas bubbles can run back into the process piping.
- When measuring in media with solid parts, such as dirty liquids, installing separators and drain valves is useful for capturing and removing sediment.

Installation position for level measurement

Level measurement in an open container

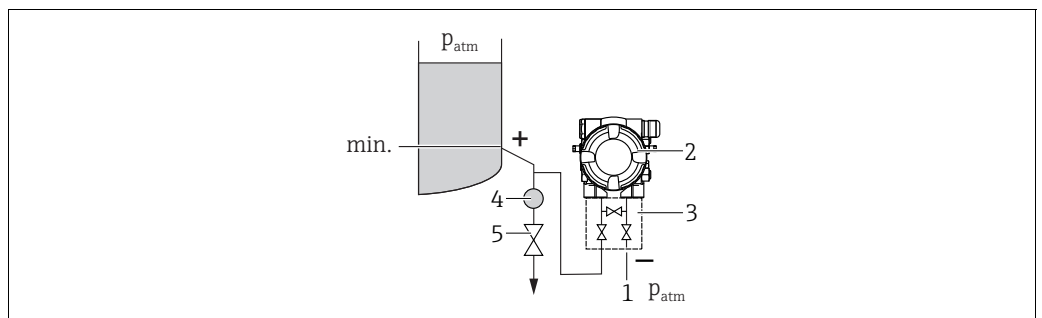

A0029787

Measuring layout for level measurement in open containers

- 1 The low-pressure side is open to atmospheric pressure
- 2 Deltabar M
- 3 Three-valve manifold
- 4 Separator
- 5 Drain valve

- Mount the Deltabar M below the lower measuring connection so that the impulse piping is always filled with liquid.
- The low-pressure side is open to atmospheric pressure.
- When measuring in media with solid parts, such as dirty liquids, installing separators and drain valves is useful for capturing and removing sediment.

Level measurement in a closed container

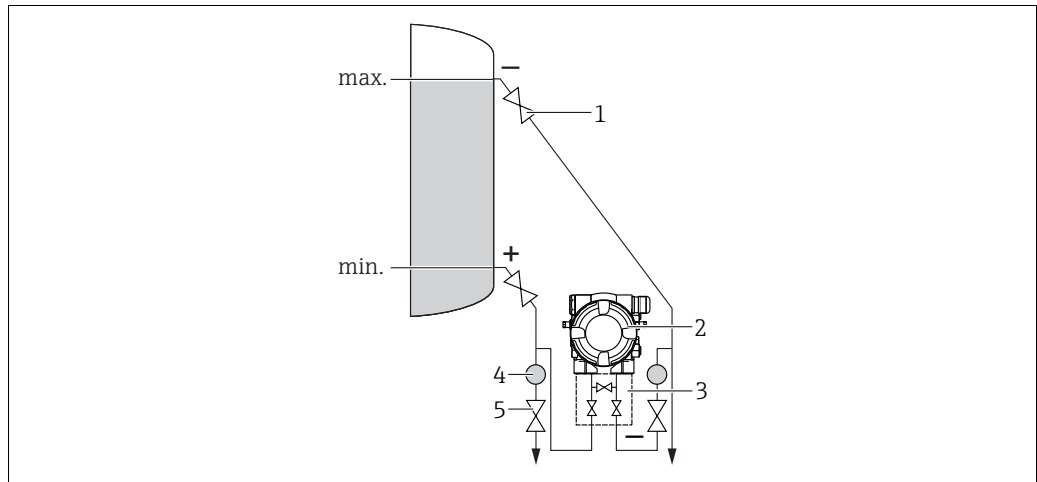

Measuring layout for level measurement in a closed container

- 1 Shut-off valves
- 2 Deltabar M
- 3 Three-valve manifold
- 4 Separator
- 5 Drain valves

- Mount the Deltabar M below the lower measuring connection so that the impulse piping is always filled with liquid.
- Always connect the low-pressure side above the maximum level.
- When measuring in media with solid parts, such as dirty liquids, installing separators and drain valves is useful for capturing and removing sediment.

Level measurement in a closed container with superimposed steam

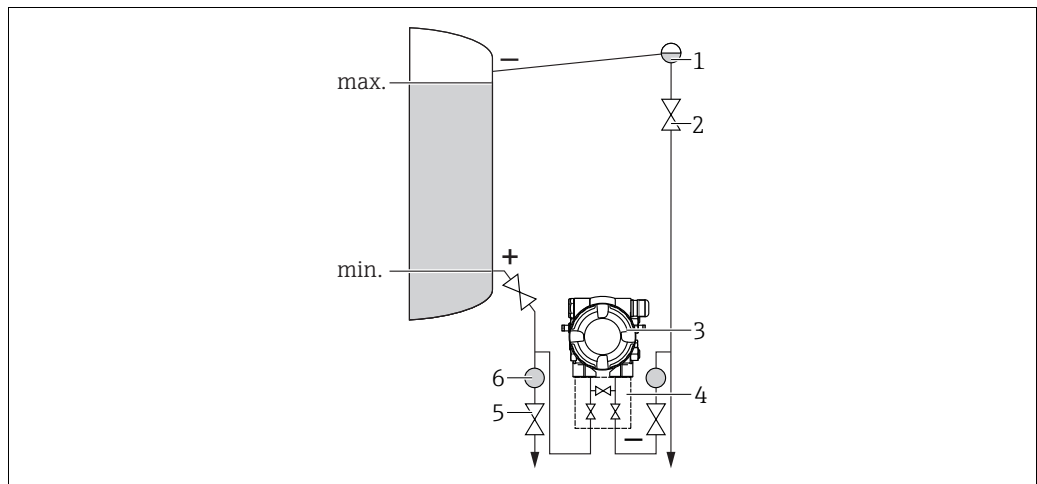

Measuring layout for level measurement in a container with superimposed steam

- 1 Condensate trap
- 2 Shut-off valves
- 3 Deltabar M
- 4 Three-valve manifold
- 5 Separator
- 6 Drain valves

- Mount the Deltabar M below the lower measuring connection so that the impulse piping is always filled with liquid.
- Always connect the low-pressure side above the maximum level.
- A condensate trap ensures constant pressure on the low-pressure side.

- When measuring in media with solid parts, such as dirty liquids, installing separators and drain valves is useful for capturing and removing sediment.

Installation position for differential pressure measurement

Differential pressure measurement in gases and steam

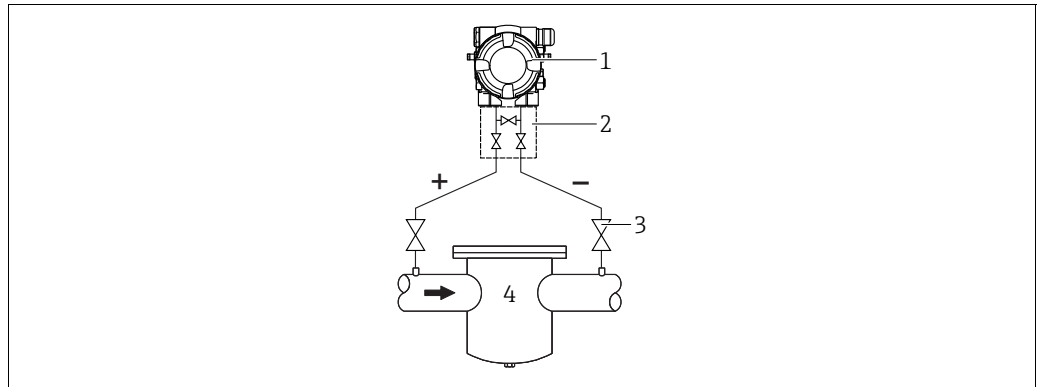

Measuring layout for differential pressure measurement in gases and steam

- 1 Deltabar M
- 2 Three-valve manifold
- 3 Shut-off valves
- 4 e.g. filter

- Mount the Deltabar M above the measuring point so that the condensate which may be present, can run off into the process piping.

Differential pressure measurement in liquids

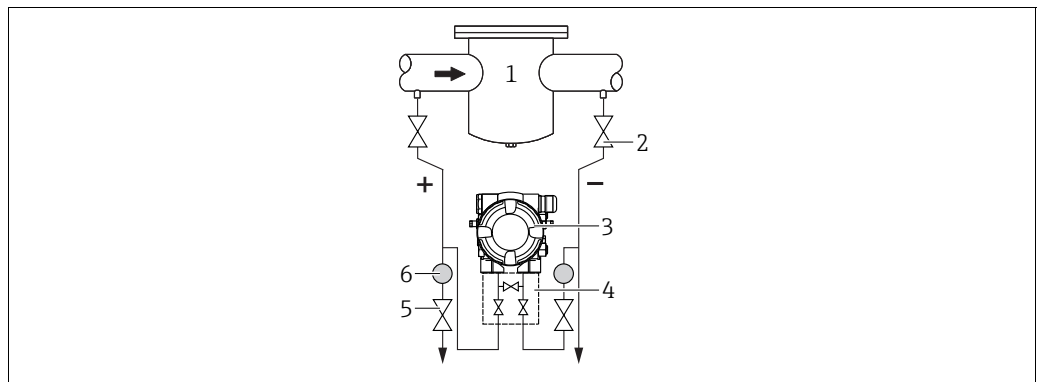

Measuring layout for differential pressure measurement in liquids

- 1 e.g. filter
- 2 Shut-off valves
- 3 Deltabar M
- 4 Three-valve manifold
- 5 Separator
- 6 Drain valves

- Mount the Deltabar M below the measuring point so that the impulse piping is always filled with liquid and gas bubbles can run back into the process piping.
- When measuring in media with solid parts, such as dirty liquids, installing separators and drain valves is useful for capturing and removing sediment.

4.6.2 Wall and pipe-mounting (option)

Endress+Hauser offers the following mounting brackets for installing the device on pipes or walls:

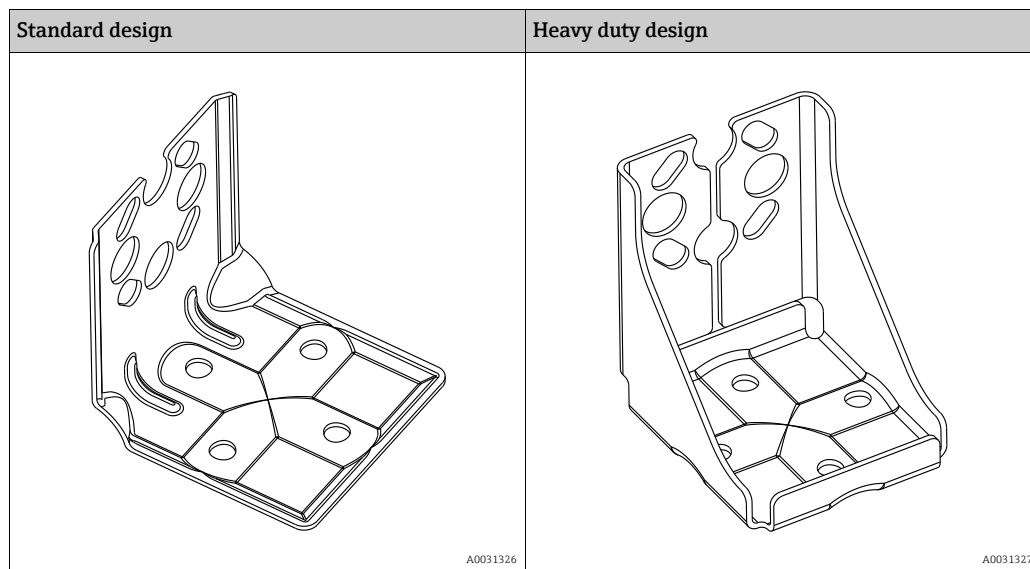

When using a valve block, the block's dimensions must be taken into account.
 Bracket for wall and pipe mounting including retaining bracket for pipe mounting and two nuts.
 material of the screws used to secure the device depend on the order code.
 Technical data (e.g. dimensions or order numbers for screws) see accessory document SD01553P/00/EN.

Please note the following when mounting:

- To prevent the mounting screws from scoring, lubricate them with a multi-purpose grease prior to mounting.
- In the case of pipe mounting, the nuts on the bracket must be tightened uniformly with a torque of at least 30 Nm (22.13 lbf ft).
- For installation purposes, only use the screws with item number (2) (see the following diagram).

NOTICE**Incorrect handling!**

Damage of the device!

- ▶ Disassembly of the screws with item number (1) is not permissible under any circumstances and will result in loss of warranty.

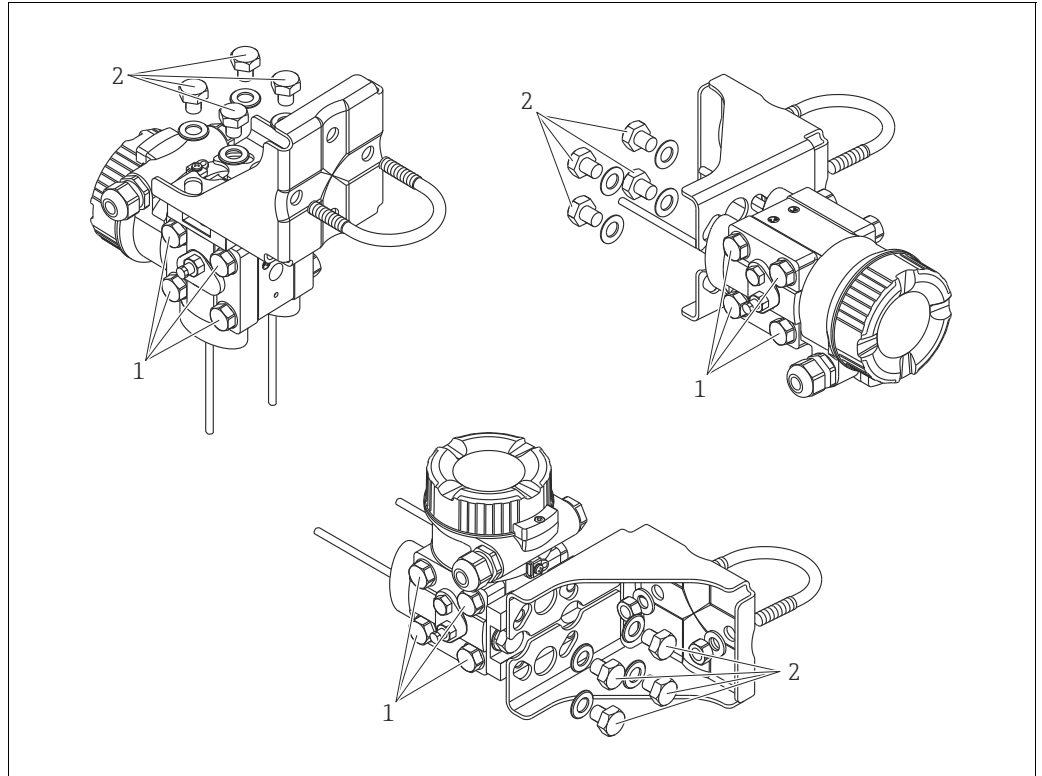

A0024167.eps

Typical installation arrangements

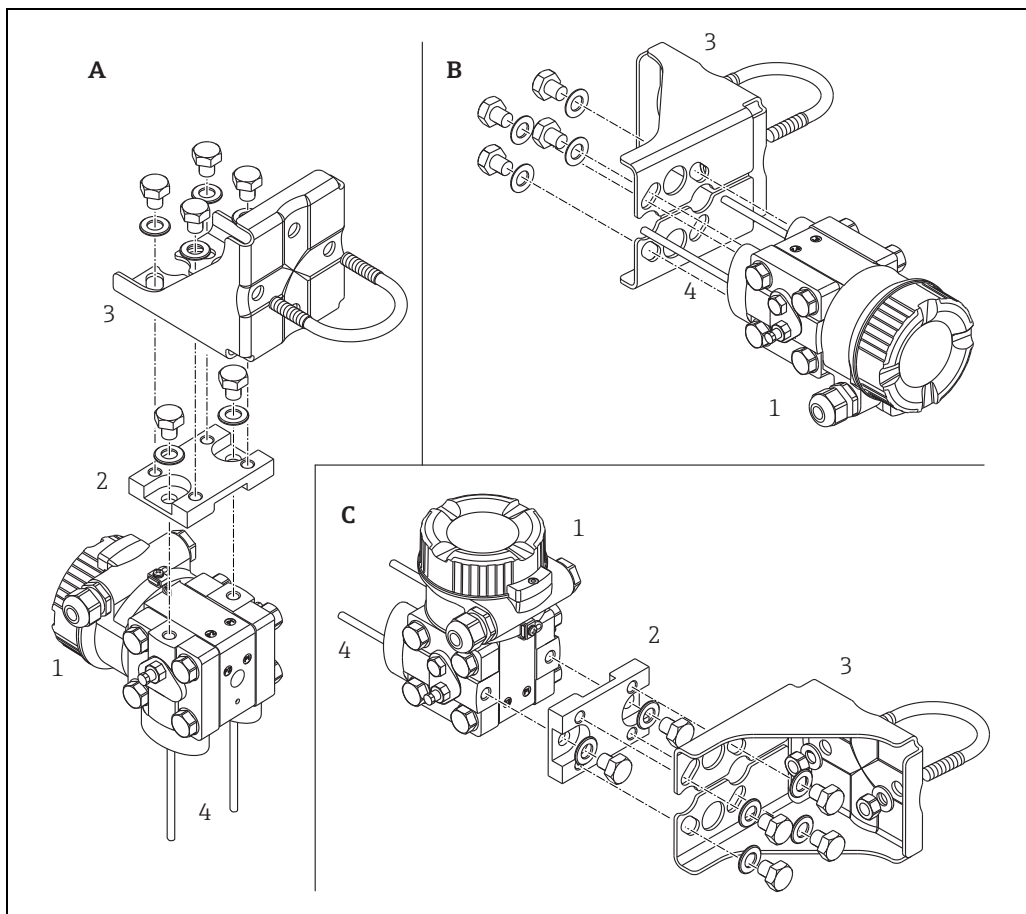

A0023109

Abb. 16:

- A Impulse line vertical, version V1, alignment 90°
- B Impulse line horizontal, version H1, alignment 180°
- C Impulse line horizontal, version H2, alignment 90°
- 1 Deltabar M
- 2 Adapter plate
- 3 Mounting bracket
- 4 Pressure line

4.7 Installing Deltapilot M

- Due to the orientation of the Deltapilot M, there may be a shift in the zero point, i.e. when the container is empty or partially full, the measured value does not display zero. You can correct this zero point shift → § 47, Section "Function of the operating elements" or → § 86, Section 8.3 "Position zero adjustment".
- The local display can be rotated in 90° stages.
- Endress+Hauser offers a mounting bracket for installing on pipes or walls. → § 22, Section 4.5.5 "Wall and pipe mounting (optional)".

4.7.1 General installation instructions

- Do not clean or touch process isolating diaphragms with hard or pointed objects.
- The process isolating diaphragm in the rod and cable version is protected against mechanical damage by a plastic cap.
- If a heated Deltapilot M is cooled during the cleaning process (e.g. by cold water), a vacuum develops for a short time, whereby moisture can penetrate the sensor through the pressure compensation (1). If this is the case, mount the Deltapilot M with the pressure compensation (1) pointing downwards.

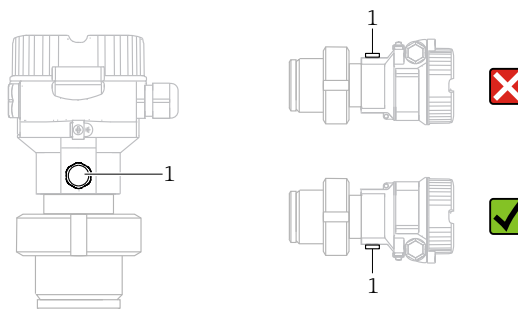

- Keep the pressure compensation and GORE-TEX® filter (1) free from contamination.
- The device must be installed as follows in order to comply with the cleanability requirements of the ASME-BPE (Part SD Cleanability):

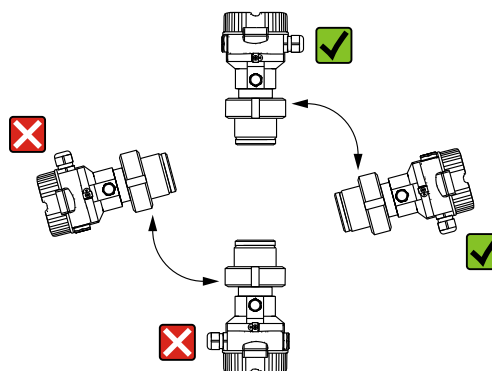

4.7.2 FMB50

Level measurement

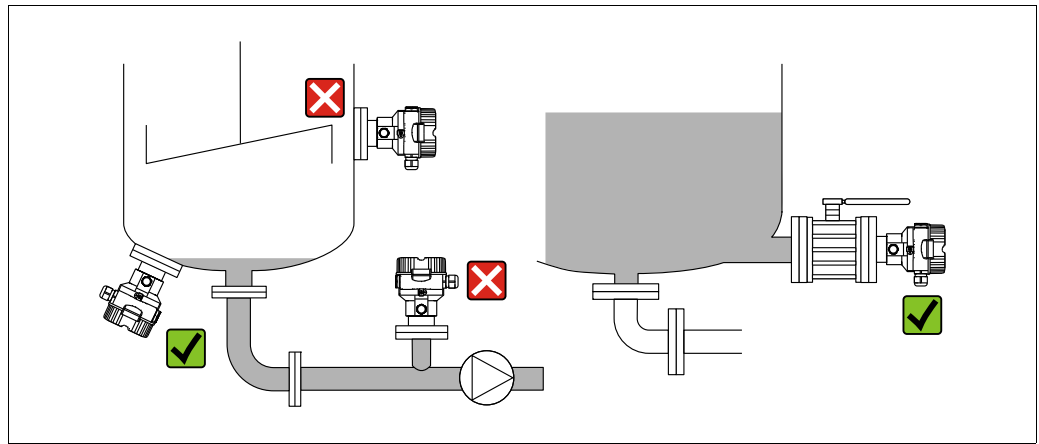

Fig. 17: Measuring arrangement for level

- Always install the device below the lowest measuring point.
- Do not install the device at the following positions:
 - in the filling curtain
 - in the tank outflow
 - in the suction area of a pump
 - or at a point in the tank that can be affected by pressure pulses from the agitator
- The calibration and functional test can be carried out more easily if you mount the device downstream of a shutoff device.
- Deltapilot M must be included in the insulation for media that can harden when cold.

Pressure measurement in gases

- Mount Deltapilot M with shutoff device above the tapping point so that any condensate can flow into the process.

Pressure measurement in steams

- Mount Deltapilot M with siphon above the tapping point.
- Fill the siphon with liquid before commissioning.
The siphon reduces the temperature to almost the ambient temperature.

Pressure measurement in liquids

- Mount Deltapilot M with the shutoff device below or at the same level as the tapping point.

4.7.3 FMB51/FMB52/FMB53

- When mounting rod and cable versions, make sure that the probe head is located at a point as free as possible from flow. To protect the probe from impact resulting from lateral movement, mount the probe in a guide tube (preferably made of plastic) or secure it with a clamping fixture.
- In the case of devices for hazardous areas, comply strictly with the safety instructions when the housing cover is open.
- The length of the extension cable or the probe rod is based on the planned level zero point. The height of the protective cap must be taken into consideration when designing the layout of the measuring point. The level zero point (E) corresponds to the position of the process isolating diaphragm. Level zero point = E; top of the probe = L.

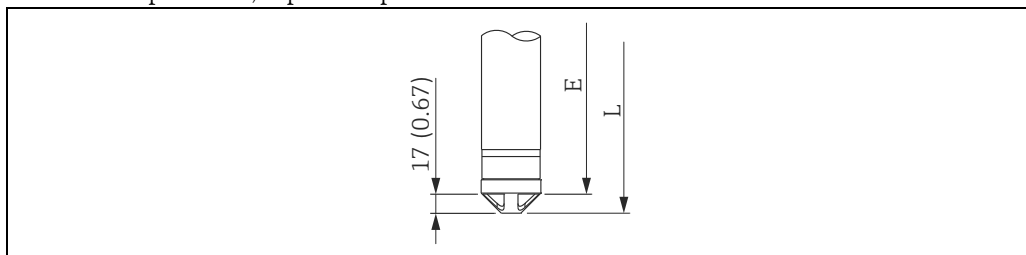

4.7.4 Mounting the FMB53 with a suspension clamp

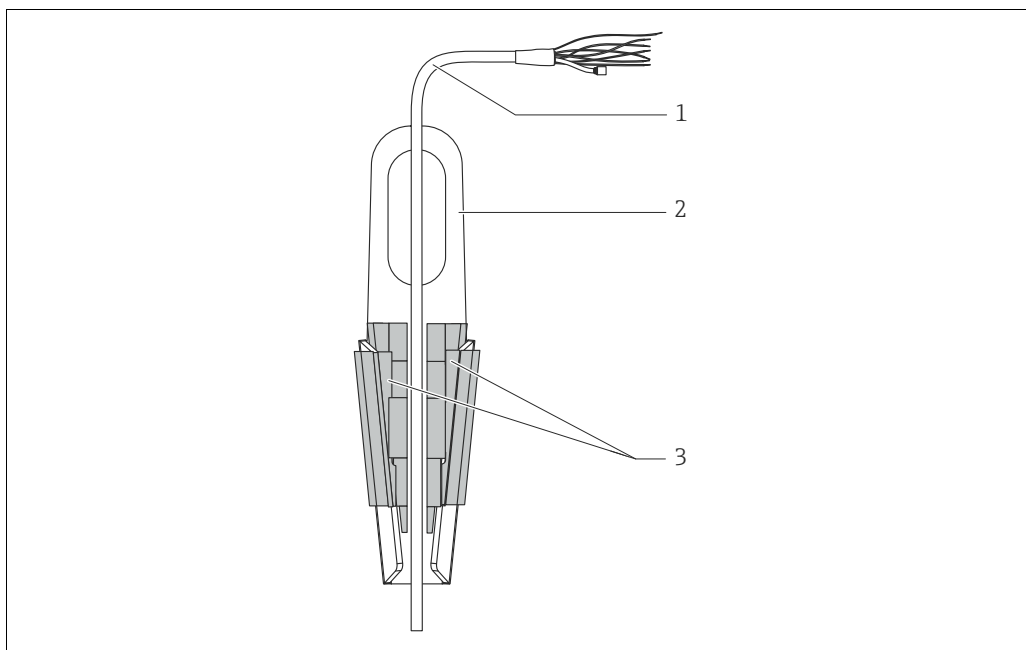

Fig. 18: Mounting with a suspension clamp

- 1 Extension cable
- 2 Suspension clamp
- 3 Clamping jaws

Mounting the suspension clamp:

1. Mount the suspension clamp (item 2). When selecting the place to fix the unit, take the weight of the extension cable (item 1) and the device into account.
2. Raise the clamping jaws (item 3). Position the extension cable (item 1) between the clamping jaws as illustrated in Figure.
3. Hold the extension cable in position (item 1) and push the clamping jaws (item 3) back down. Tap the clamping jaws gently from above to fix them in place.

4.7.5 Seal for flange mounting

NOTICE

Distorted measurement results.

The seal is not allowed to press on the process isolating diaphragm as this could affect the measurement result.

- ▶ Ensure that the seal is not touching the process isolating diaphragm.

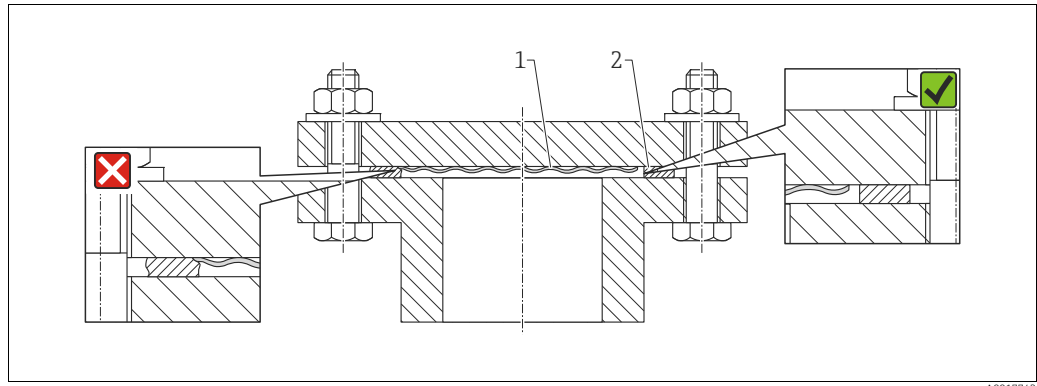
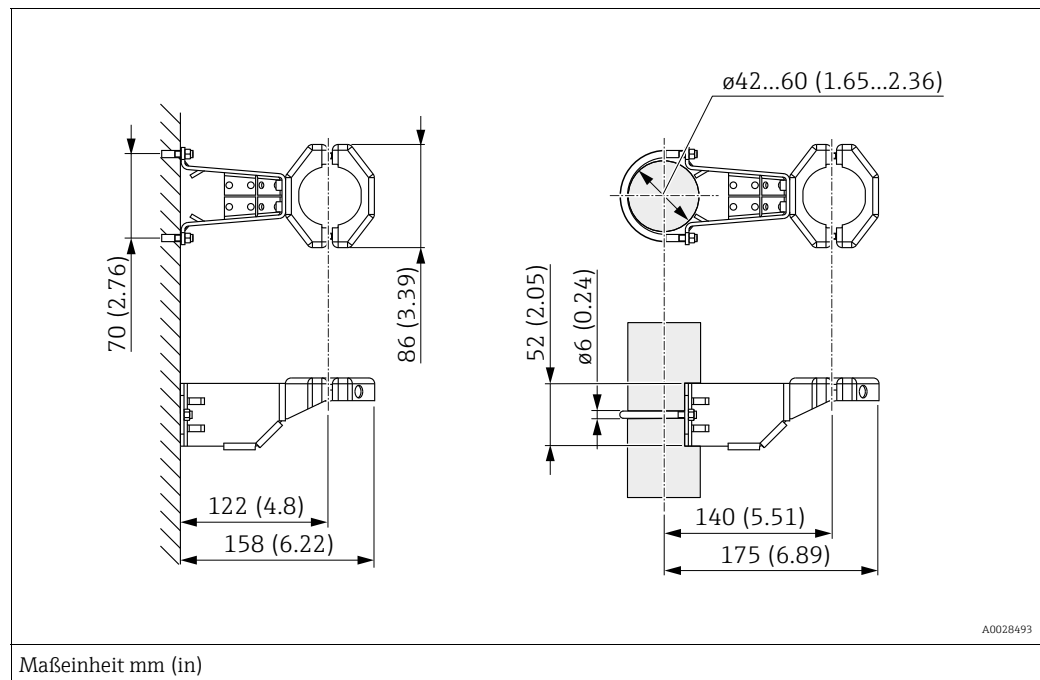

Fig. 19:
1 Process isolating diaphragm
2 Seal

4.7.6 Wall and pipe mounting (optional)

Mounting bracket

Endress+Hauser offers a mounting bracket for installing on pipes or walls (for pipes from 1 1/4" up to 2" diameter).



In the case of pipe mounting, the nuts on the bracket must be tightened uniformly with a torque of at least 5 Nm (3.69 lbf ft).

4.7.7 Assembling and mounting the "separate housing" version

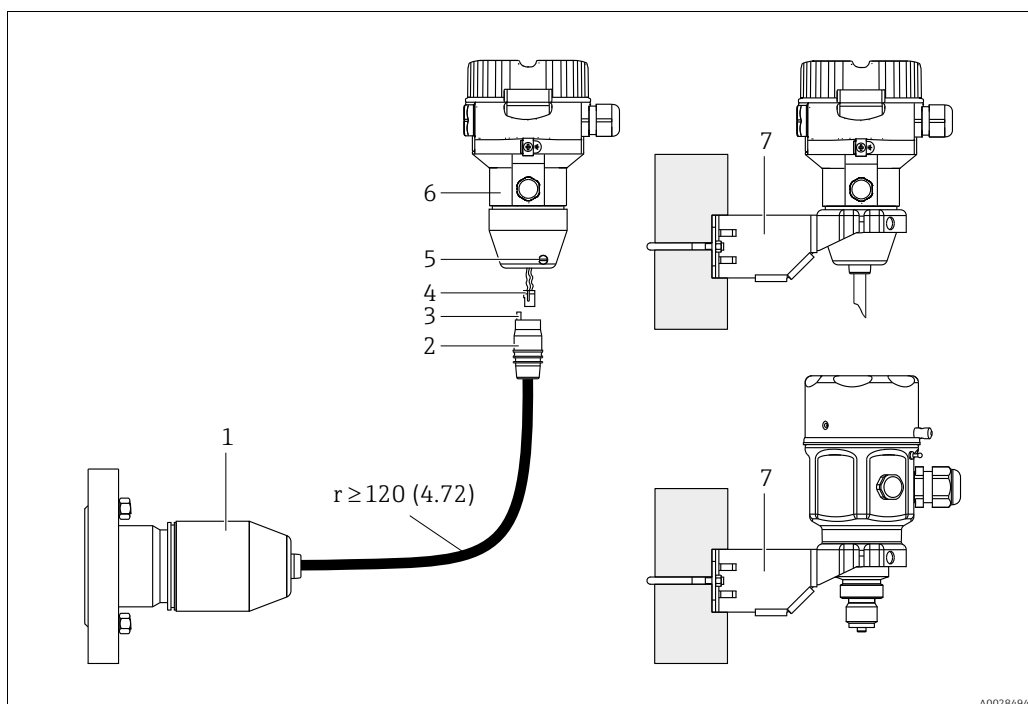

Fig. 20: "Separate housing" version

- 1 In the case of the "separate housing" version, the sensor is delivered with the process connection and cable ready mounted.
 2 Cable with connection jack
 3 Pressure compensation
 4 Connector
 5 Locking screw
 6 Housing mounted with housing adapter, included
 7 Mounting bracket provided, suitable for pipe and wall mounting (for pipes from 1 1/4" up to 2" diameter)

Maßeinheit mm (in)

Assembly and mounting

1. Insert the connector (item 4) into the corresponding connection jack of the cable (item 2).
2. Plug the cable into the housing adapter (item 6).
3. Tighten the locking screw (item 5).
4. Mount the housing on a wall or pipe using the mounting bracket (item 7).
 When mounting on a pipe, tighten the nuts on the bracket uniformly with a torque of at least 5 Nm (3.69 lbf ft).
 Mount the cable with a bending radius (r) ≥ 120 mm (4.72 in).

Routing the cable (e.g. through a pipe)

You require the cable shortening kit.

Order number: 71093286

For details on mounting, see SD00553P/00/A6.

4.7.8 Supplementary installation instructions

Sealing the probe housing

- Moisture must not penetrate the housing when mounting the device, establishing the electrical connection and during operation.
- Always firmly tighten the housing cover and the cable entries.

4.8 Installing profile seal for universal process adapter

For mounting details, see KA00096F/00/A3.

4.9 Closing the housing cover

NOTICE

Devices with EPDM cover seal - transmitter leakiness!

Mineral-based, animal-based or vegetable-based lubricants cause the EPDM cover seal to swell and the transmitter to become leaky.

- ▶ The thread is coated at the factory and therefore does not require any lubrication.

NOTICE

The housing cover can no longer be closed.

Damaged thread!

- ▶ When closing the housing cover, please ensure that the thread of the cover and housing are free from dirt, e.g. sand. If you feel any resistance when closing the cover, check the thread on both again to ensure that they are free from dirt.

4.9.1 Closing the cover on the stainless steel housing

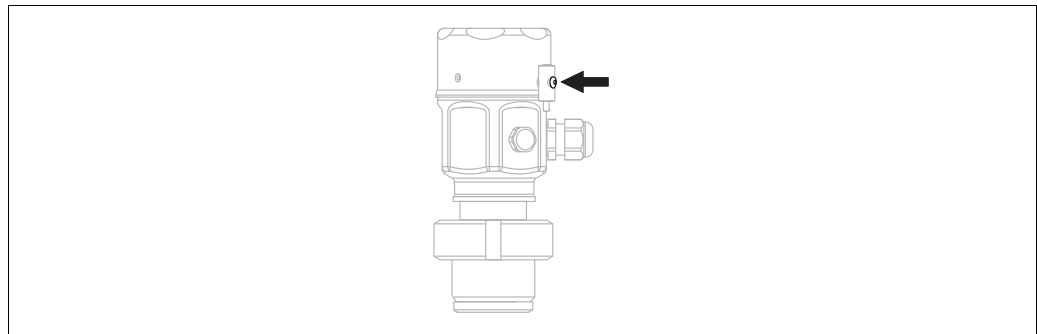

Fig. 21: Closing the cover

The cover for the electronics compartment is tightened by hand at the housing until the stop. The screw serves as DustEx protection (only available for devices with DustEx approval).

4.10 Post-installation check

0	Is the device undamaged (visual inspection)?
0	Does the device comply with the measuring point specifications? For example: <ul style="list-style-type: none"> ▪ Process temperature ▪ Process pressure ▪ Ambient temperature range ▪ Measuring range
0	Are the measuring point identification and labeling correct (visual inspection)?
0	Is the device adequately protected against precipitation and direct sunlight?
0	Are the securing screw and securing clamp tightened securely?

5 Electrical connection

5.1 Connecting the device

⚠ WARNING

Supply voltage might be connected!

Risk of electric shock and/or explosion!

- ▶ Ensure that no uncontrolled processes are activated in the system.
- ▶ Switch off the supply voltage before connecting the device.
- ▶ When using the measuring device in hazardous areas, installation must comply with the corresponding national standards and regulations and the Safety Instructions or Installation or Control Drawings.
- ▶ A suitable circuit breaker must be provided for the device in accordance with IEC/EN61010.
- ▶ Devices with integrated overvoltage protection must be grounded.
- ▶ Protective circuits against reverse polarity, HF influences and overvoltage peaks are integrated.

Connect the device in the following order:

1. Check that the supply voltage corresponds to the supply voltage indicated on the nameplate.
2. Switch off the supply voltage before connecting the device.
3. Remove housing cover.
4. Guide the cable through the gland. Preferably use a twisted, shielded two-wire cable.
5. Connect the device in accordance with the following diagram.
6. Screw down the housing cover.
7. Switch on the supply voltage.

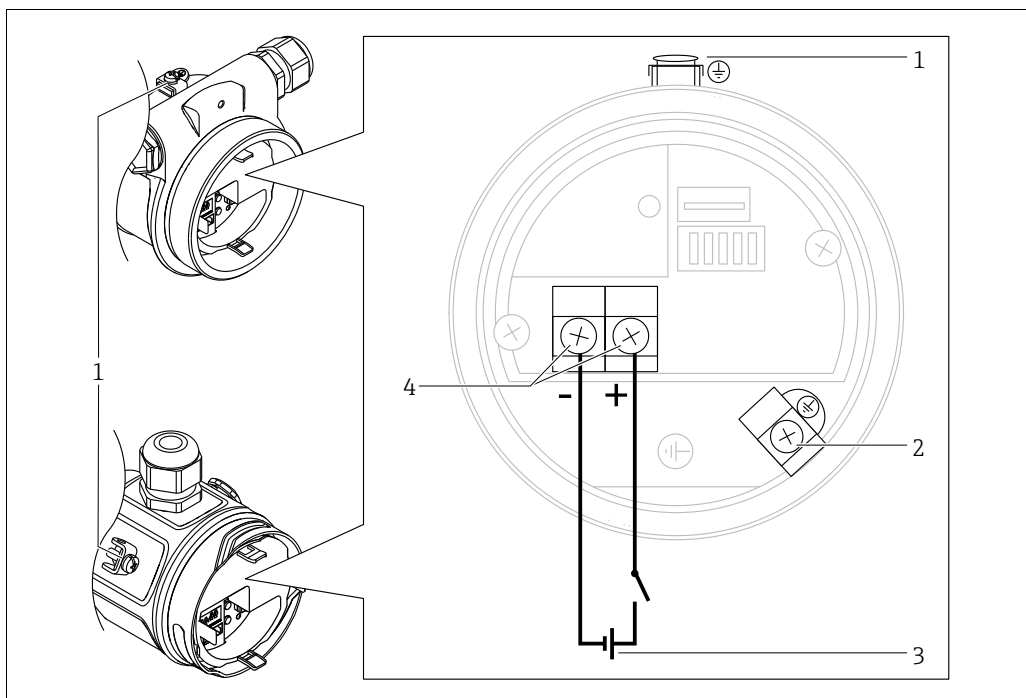

PROFIBUS PA electrical connection

- 1 External ground terminal
- 2 Grounding terminal
- 3 Supply voltage: 9 to 32 VDC (Segment coupler)
- 4 Terminals for supply voltage and signal

A0029967

5.1.1 Devices with M12 connector

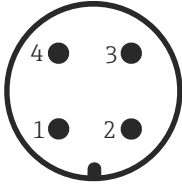
PIN assignment for M12 connector	PIN	Meaning
	1	Signal +
	2	Not assigned
	3	Signal -
	4	Earth

5.2 Connecting the measuring unit



For further information on the network structure and grounding and for further bus system components such as bus cables, see the relevant documentation, e.g. Operating Instructions BA00034S "PROFIBUS DP/PA: Guidelines for planning and commissioning" and the PNO Guideline.

5.2.1 Supply voltage

Electronic version	
PROFIBUS PA, version for non-hazardous areas	9 to 32 V DC

5.2.2 Current consumption

11 mA ±1 mA, switch-on current corresponds to IEC 61158-2, Clause 21.

5.2.3 Terminals

- Supply voltage and internal ground terminal: 0.5 to 2.5 mm² (20 to 14 AWG)
- External ground terminal: 0.5 to 4 mm² (20 to 12 AWG)

5.2.4 Cable specification

- Use a twisted, shielded two-wire cable, preferably cable type A.
- Cable outer diameter: 5 to 9 mm (0.2 to 0.35 in)



For further information on the cable specifications, see Operating Instructions BA00034S "PROFIBUS DP/PA: Guidelines for planning and commissioning", the PNO Guideline 2.092 "PROFIBUS PA User and Installation Guideline" and IEC 61158-2 (MBP).

5.2.5 Shielding/potential equalization

- You achieve optimum shielding against disturbances if the shielding is connected on both sides (in the cabinet and on the device). If potential equalization currents are expected in the plant, only ground shielding on one side, preferably at the transmitter.
- When using in hazardous areas, you must observe the applicable regulations. Separate Ex documentation with additional technical data and instructions is included with all Ex systems as standard.

5.3 Potential equalization

Hazardous area applications: Connect all devices to the local potential equalization. Observe the applicable regulations.

5.4 Overvoltage protection (optional)

Devices showing version "NA" in feature 610 "Mounted accessories" in the order code are equipped with a surge arrester (see Technical Information "Ordering information" section). The surge arrester is mounted at the factory on the housing thread for the cable gland and is approx. 70 mm (2.76 in) in length (take additional length into account when installing). The device is connected as specified in the following graphic. For details refer to TI001013KEN, XA01003KA3 and BA00304KA2.

5.4.1 Wiring

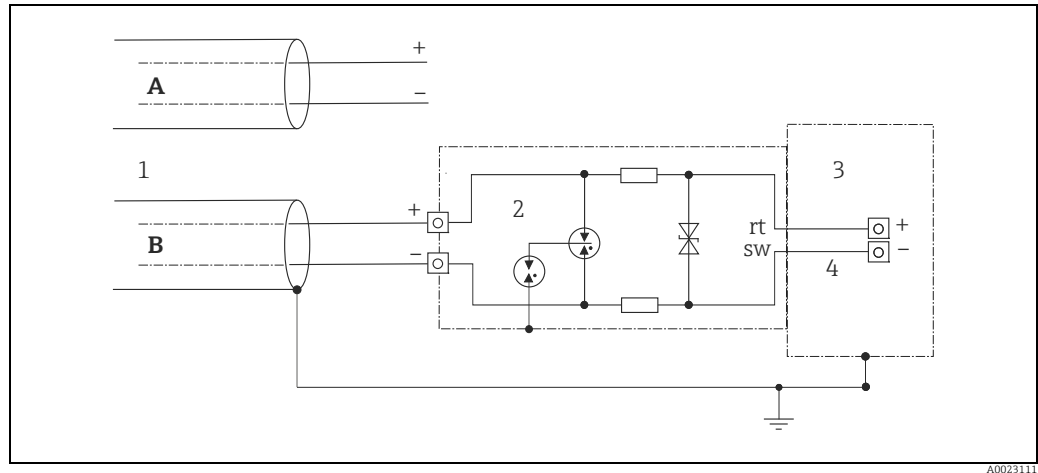
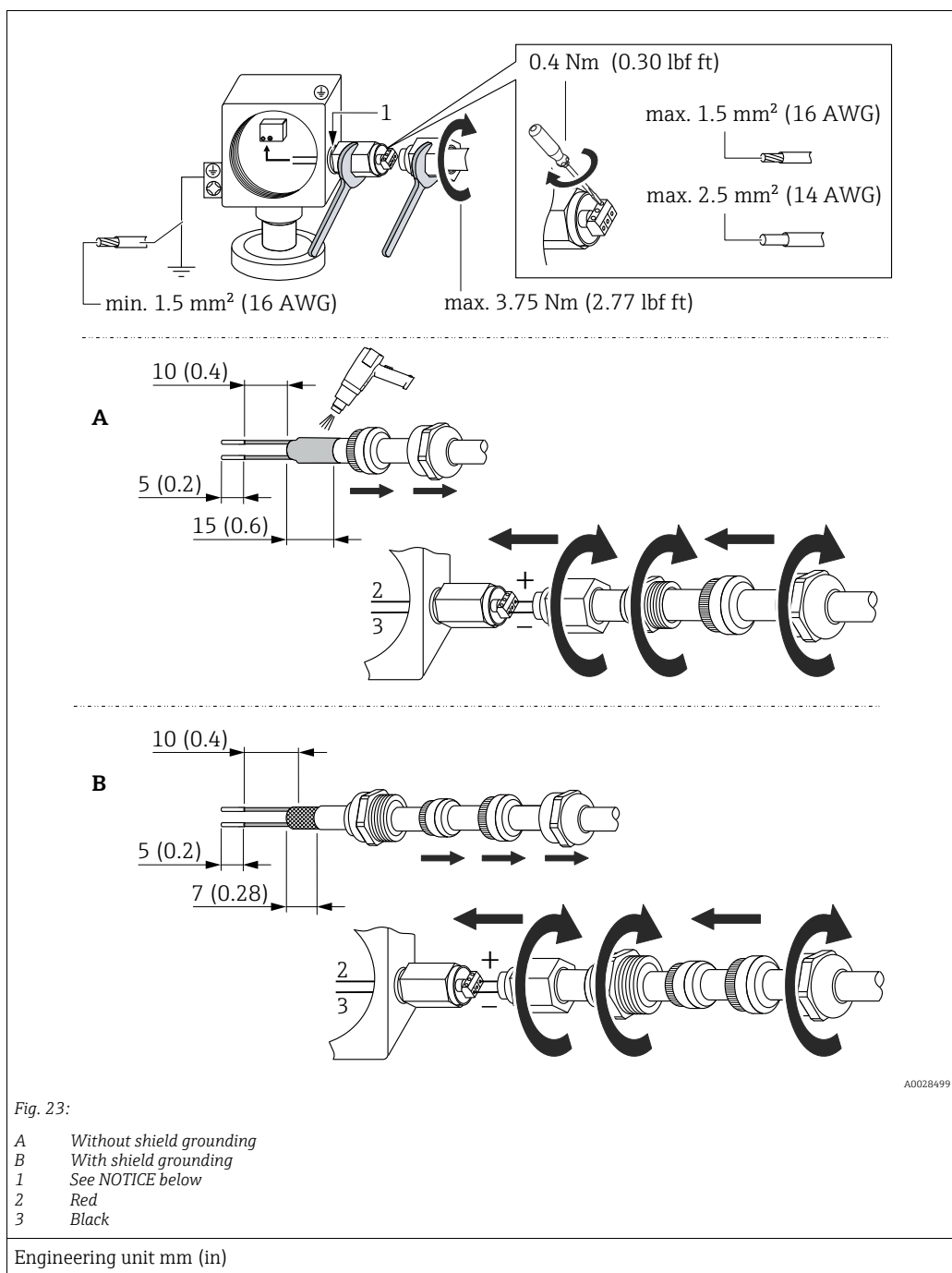

Fig. 22:

- A Without direct shield grounding
- B With direct shield grounding
- 1 Incoming connection cable
- 2 HAW569-DA2B
- 3 Unit to be protected
- 4 Connection cable

A0023111

5.4.2 Installation



NOTICE

Screw connection glued at factory!

Damage to the device and/or surge arrester!

- ▶ When releasing/tightening the union nut use a wrench to hold the screw steady so it does not turn.

5.5 Post-connection check

Perform the following checks after completing electrical installation of the device:

- Does the supply voltage match the specifications on the nameplate?
- Is the device properly connected?
- Are all screws firmly tightened?
- Are the housing covers screwed down tight?

As soon as voltage is applied to the device, the green LED on the electronic insert lights up briefly or the connected onsite display lights up.

6 Operation

6.1 Operating options

6.1.1 Operation without an operating menu

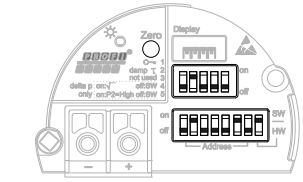
Operating options	Explanation	Graphic illustration	Description
Local operation without device display	The device is operated using the operating key and DIP switches on the electronic insert.		→ 46

6.1.2 Operation with an operating menu

Operation with an operating menu is based on an operation concept with "user roles"
 → 48.

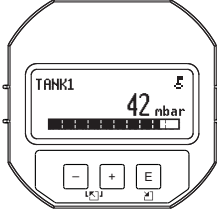
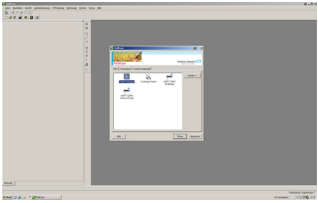
Operating options	Explanation	Graphic illustration	Description
Local operation with device display	The device is operated using the operating keys on the device display.		→ 50
Remote operation via FieldCare	The device is operated using the FieldCare operating tool.		→ 54

6.1.3 Operation via PA communication protocol

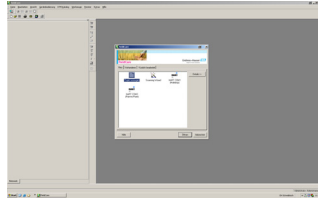
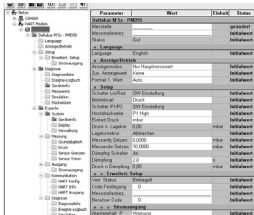
Operating options	Explanation	Graphic illustration	Description
Remote operation via FieldCare	The device is operated using the FieldCare operating tool.		→ 57
Remote operation via PDM	The device is operated using the PDM tool.		→ 57

6.2 Operation without an operating menu

6.2.1 Position of operating elements

The operating key and DIP switches are located on the electronic insert in the device.

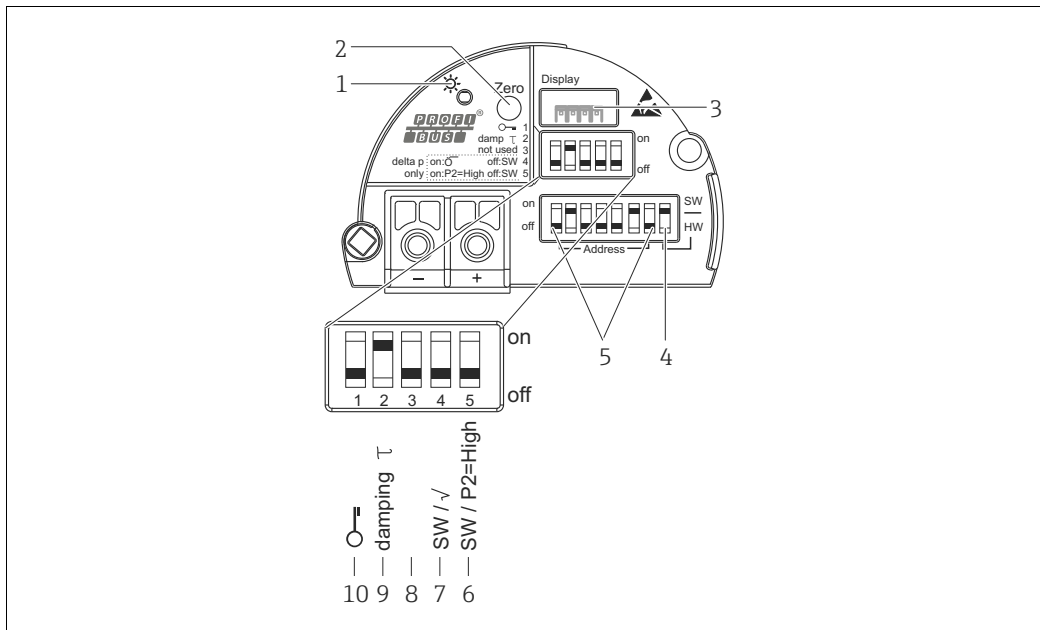

A0023126

Fig. 24: PROFIBUS PA electronic insert

- 1 Green LED to indicate successful operation
- 2 Operating key for position zero adjustment (Zero) or reset
- 3 Slot for optional local display
- 4 DIP-switch for bus address SW / HW
- 5 DIP-switch for hardware address
- 6+7 DIP switch only for Deltabar M
Switch 7: "SW/Square root"; used to control the output characteristics
Switch 6: "SW/P2-High"; used to determine the high-pressure side
- 8 Not used
- 9 DIP switch for switching damping on/off
- 10 DIP switch for locking/unlocking parameters relevant to the measured value

Function of the DIP switches

Switches	Symbol/ labeling	Switch position	
		"off"	"on"
1		The device is unlocked. Parameters relevant to the measured value can be modified.	The device is locked. Parameters relevant to the measured value cannot be modified.
2	damping τ	Damping is switched off. The output signal follows measured value changes without any delay.	Damping is switched on. The output signal follows measured value changes with the delay time τ . ¹⁾
4 (Deltabar)	SW/ $\sqrt{\quad}$	The measuring mode is "Pressure" and the output characteristics is "Linear", as per the SW default setting.	The measuring mode is "flow" and the output characteristics is "Square root" regardless of the settings in the operating menu.
5 (Deltabar)	SW/P2= High	The high-pressure side (+/HP) is defined by the setting in the operating menu. ("Setup" -> "High Press. Side")	The high-pressure side (+/HP) is allocated to the P2 pressure connection regardless of the setting in the operating menu.
6	Address	Set the device address using switches 1-7	
7	SW / HW	Hardware addressing	Software addressing

- 1) The value for the delay time can be configured via the operating menu ("Setup" -> "Damping").
Factory setting: $\tau = 2$ s or as per order specifications.

Function of the operating elements

Operating key(s)	Meaning
"Zero" pressed for at least 3 seconds	Position adjustment (zero point correction) Press key for at least 3 seconds. The LED on the electronic insert lights up briefly if the pressure applied has been accepted for position adjustment. → See also the following Section "Performing position adjustment on site."
"Zero" pressed for at least 12 seconds	Reset All parameters are reset to the order configuration.

Performing position adjustment on site

- Operation must be unlocked. →  54, Section 6.3.5 "Locking/unlocking operation".
- The device is configured at the factory for the Pressure measuring mode (Cerabar, Deltabar) or Level measuring mode (Deltapilot).
- The pressure applied must be within the nominal pressure limits of the sensor. See information on the nameplate.

Perform position adjustment:

1. Pressure is present at device.
2. Press key for at least 3 seconds.
3. If the LED on the electronic insert lights up briefly, the pressure applied has been accepted for position adjustment.
If the LED does not light up, the pressure applied was not accepted. Observe the input limits. For error messages, →  204, Section 11.1 "Messages".

6.2.2 Locking/unlocking operation

Once you have entered all the parameters, you can lock your entries against unauthorized and undesired access.



If operation is locked by means of the DIP switch, you can only unlock operation again by means of the DIP switch. If operation is locked by means of the operating menu, you can only unlock operation again using the operating menu.

Locking/unlocking via DIP switches

DIP switch 1 on the electronic insert is used to lock/unlock operation.

→ 47, "Function of the DIP switches".

6.3 Operation with an operating menu

6.3.1 Operation concept

The operation concept makes a distinction between the following user roles:

User role	Meaning
Operator	Operators are responsible for the devices during normal "operation". This is usually limited to reading process values either directly at the device or in a control room. If the work with the devices extends beyond value read-off tasks, the tasks involve simple, application-specific functions that are used in operation. Should an error occur, these users simple forward the information on the errors but do not intervene themselves.
Service engineer/ technician	Service engineers usually work with the devices in the phases following device commissioning. They are primarily involved in maintenance and troubleshooting activities for which simple settings have to be made at the device. Technicians work with the devices over the entire life cycle of the product. Thus, commissioning and advanced settings and configurations are some of the tasks they have to carry out.
Expert	Experts work with the devices over the entire product life cycle, but their device requirements are often extremely high. Individual parameters/functions from the overall functionality of the devices are required for this purpose time and again. In addition to technical, process-oriented tasks, experts can also perform administrative tasks (e.g. user administration). "Experts" can avail of the entire parameter set.

6.3.2 Structure of the operating menu

User role	Submenu	Meaning/use
Operator	Language	Only consists of the "Language" parameter (000) where the operating language for the device is specified. The language can always be changed even if the device is locked.
Operator	Display/operat.	Contains parameters that are needed to configure the measured value display (selecting the values displayed, display format, etc.). With this submenu, users can change the measured value display without affecting the actual measurement.

User role	Submenu	Meaning/use
Service engineer/ technician	Setup	<p>Contains all the parameters that are needed to commission measuring operations. This submenu has the following structure:</p> <ul style="list-style-type: none"> ▪ Standard setup parameters A wide range of parameters, which can be used to configure a typical application, is available at the start. The measuring mode selected determines which parameters are available. After making settings for all these parameters, the measuring operation should be completely configured in the majority of cases. ▪ "Extended setup" submenu The "Extended setup" submenu contains additional parameters for more in-depth configuration of the measurement operation to convert the measured value and to scale the output signal. This menu is split into additional submenus depending on the measuring mode selected.
Service engineer/ technician	Diagnosis	<p>Contains all the parameters that are needed to detect and analyze operating errors. This submenu has the following structure:</p> <ul style="list-style-type: none"> ▪ Diagnostic list Contains up to 10 error messages currently pending. ▪ Event logbook Contains the last 10 error messages (no longer pending). ▪ Instrument info Contains information on the device identification. ▪ Measured values Contains all the current measured values ▪ Simulation Is used to simulate pressure, level, flow and alarm/warning. ▪ Reset
Expert	Expert	<p>Contains all the parameters of the device (including those in one of the submenus). The "Expert" submenu is structured by the function blocks of the device. It thus contains the following submenus:</p> <ul style="list-style-type: none"> ▪ System Contains general device parameters that neither affect measurement nor integration into a distributed control system. ▪ Measurement Contains all the parameters for configuring the measurement. ▪ Communication Contains the parameters of the PROFIBUS PA interface. ▪ Application Contains all the parameters for configuring the functions that go beyond the actual measurement (e.g. totalizer). ▪ Diagnosis Contains all the parameters that are needed to detect and analyze operating errors.



For an overview of the entire operating menu: → 119 ff.

Direct access to parameters

The parameters can only be accessed directly via the "Expert" user role.

Parameter name	Description
<p>Direct access (119) Entry</p> <p> Menu path: Expert → Direct access</p>	<p>Use this function to enter a parameter code for direct access.</p> <p>User input:</p> <ul style="list-style-type: none"> ▪ Enter the desired parameter code. <p>Factory setting: 0</p>

6.3.3 Operation with a device display (optional)

A 4-line liquid crystal display (LCD) is used for display and operation. The onsite display shows measured values, dialog texts, fault messages and notice messages.

For easy operation the display can be taken out of the housing (see figure steps 1 to 3). It is connected to the device through a 90 mm (3.54 in) cable.

The display of the device can be turned in 90° stages (see figure steps 4 to 6).

Depending on the orientation of the device, this makes it easy to operate the device and read the measured values.

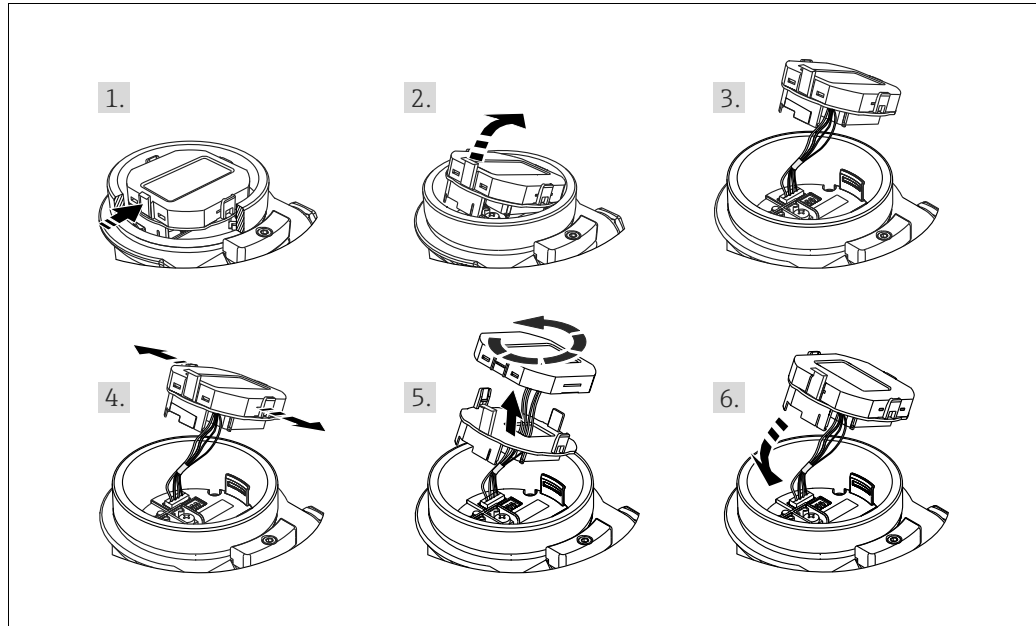

A0028500

Functions:

- 8-digit measured value display including sign and decimal point.
- Bar graph as graphic display of the standardized value of the Analog Input Block (→ see also → 151, Section 9.3.1 "Scaling the output value (Out Value)", graphic)
- Three keys for operation
- Simple and complete menu guidance as parameters are split into several levels and groups
- Each parameter is given a 3-digit parameter code for easy navigation
- Possibility of configuring the display to suit individual requirements and preferences, such as language, alternating display, display of other measured values such as sensor temperature, contrast setting.
- Comprehensive diagnostic functions (fault and warning message etc.)

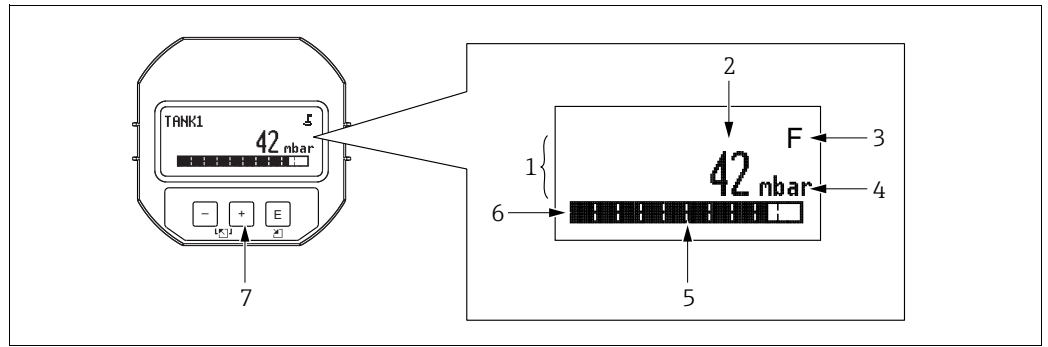

Fig. 25: Display

- 1 Main line
- 2 Value
- 3 Symbol
- 4 Unit
- 5 Bar graph
- 6 Information line
- 7 Operating keys

The following table illustrates the symbols that can appear on the onsite display. Four symbols can occur at one time.

Symbol	Meaning
🔒	Lock symbol The operation of the device is locked. To unlock the device, → 54, Locking/ unlocking operation.
☎	Communication symbol Data transfer via communication
√	Square root symbol (only Deltabar M) Active measuring mode "Flow measurement"
S	Error message "Out of specification" The device is being operated outside its technical specifications (e.g. during warmup or cleaning processes).
C	Error message "Service mode" The device is in the service mode (during a simulation, for example).
M	Error message "Maintenance required" Maintenance is required. The measured value remains valid.
F	Error message "Failure detected" An operating error has occurred. The measured value is no longer valid.

Operating keys on the display and operating module

Operating key(s)	Meaning
<input type="button" value="+"/>	<ul style="list-style-type: none"> - Navigate downwards in the picklist - Edit the numerical values and characters within a function
<input type="button" value="-"/>	<ul style="list-style-type: none"> - Navigate upwards in the picklist - Edit the numerical values and characters within a function
<input type="button" value="E"/>	<ul style="list-style-type: none"> - Confirm entry - Jump to the next item - Selection of a menu item and activation of the editing mode
<input type="button" value="+"/> and <input type="button" value="E"/>	Contrast setting of onsite display: darker
<input type="button" value="-"/> and <input type="button" value="E"/>	Contrast setting of onsite display: brighter
<input type="button" value="+"/> and <input type="button" value="-"/>	ESC functions: <ul style="list-style-type: none"> - Exit the edit mode for a parameter without saving the changed value. - You are in a menu at a selection level. Each time you press the keys simultaneously, you go up a level in the menu.

Operating example: Parameters with a picklist

Example: selecting "Deutsch" as the language of the menu.

	Language	000	Operation
1	<ul style="list-style-type: none"> ✓ English Deutsch 		"English" is set as the menu language (default value). A ✓ in front of the menu text indicates the active option.
2	<ul style="list-style-type: none"> Deutsch ✓ English 		Select "Deutsch" with <input type="button" value="⊕"/> or <input type="button" value="⊖"/> .
3	<ul style="list-style-type: none"> ✓ Deutsch English 		<ol style="list-style-type: none"> 1. Confirm your choice with <input type="button" value="E"/>. A ✓ in front of the menu text indicates the active option ("Deutsch" is now selected as the menu language). 2. Exit the edit mode for the parameter with <input type="button" value="E"/>.

Operating example: User-definable parameters

Example: setting "Set URV" parameter from 100 mbar (1.5 psi) to 50 mbar (0.75 psi).

	Set URV	014	Operation
1	1 0 0 . 0 0 0	mbar	The local display shows the parameter to be changed. The value highlighted in black can be changed. The "mbar" unit is specified in another parameter and cannot be modified here.
2	1 0 0 . 0 0 0	mbar	1. Press \boxplus or \boxminus to get to the editing mode. 2. The first digit is highlighted in black.
3	5 0 0 . 0 0 0	mbar	1. Use \boxplus to change "1" to "5". 2. Confirm "5" with \boxtimes . The cursor jumps to the next position (highlighted in black). 3. Confirm "0" with \boxtimes (second position).
4	5 0 0 . 0 0 0	mbar	The third position is highlighted in black and can now be edited.
5	5 0 . 0 0 0	mbar	1. Switch to the "." symbol with the \boxminus key. 2. Use \boxtimes to save the new value and exit the editing mode. → See next graphic.
6	5 0 . 0 0 0	mbar	The new value for the upper range value is 50.0 mbar (0.75 psi). – You exit the edit mode for the parameter with \boxtimes . – You can get back to the editing mode with \boxplus or \boxminus .

Operating example: Accepting the pressure present



Example: setting position adjustment

	Pos. zero adjust	007	Operation
1	✓ Abort Confirm		The pressure for position adjustment is present at the device.
2	Confirm ✓ Abort		Use \boxplus or \boxminus to switch to the "Confirm" option. The active option is highlighted in black.
3	Compensation accepted!		Accept the pressure present as position adjustment with the \boxtimes key. The device confirms the adjustment and goes back to the "Pos. zero adjust" parameter.
4	✓ Abort Confirm		Exit the edit mode for the parameter with \boxtimes .

6.3.4 Operation via FieldCare

FieldCare is an Endress+Hauser asset management tool based on FDT technology. With FieldCare, you can configure all Endress+Hauser devices as well as devices from other manufacturers that support the FDT standard. Hard- and software requirements can be found on the Internet: www.endress.com → Search for: FieldCare → FieldCare → Technical data.

FieldCare supports the following functions:

- Configuration of transmitters in online/offline mode
- Loading and saving device data (upload/download): see "Download select." parameter →  129 in the operating menu or via Physical Block →  165.
- Documentation of the measuring point
- Offline parametrization of transmitters



- In "Level expert" measuring mode, the configuration data which were generated by FDT upload cannot be saved back again (FDT download); they are used solely to document the configuration.
- Further information on FieldCare can be found on the Internet (<http://www.endress.com>, Download → Search for: FieldCare).
- As not all internal device dependencies can be mapped in offline operation, the consistency of the parameters must be checked before the parameters are transmitted to the device. The DIP switches must be set to the as-delivered state for this purpose (see Figure →  46). When commissioning for the first time, "Download select." must be set to "Device replacement".

6.3.5 Locking/unlocking operation

Once you have entered all the parameters, you can lock your entries against unauthorized and undesired access.

Locked operation is indicated as follows:



- By the  symbol on the onsite display
- The parameters are grayed out in FieldCare and the handheld terminal, which means they cannot be edited. Indicated in the corresponding "Lockstate" parameter.

Parameters which refer to how the display appears, e.g. "Language (000)", can still be altered.



If operation is locked by means of the DIP switch, you can only unlock operation again by means of the DIP switch. If operation is locked by means of the operating menu, you can only unlock operation again using the operating menu.

The "Operator code (021)" parameter is used to lock and unlock the device.

Parameter name	Description
Operator code (021) Entry  Menu path: Setup → Extended setup → Operator code	Use this function to enter a code to lock or unlock operation. User input: <ul style="list-style-type: none"> ▪ To lock: Enter a number ≠ the release code (value range: 1 to 9999). ▪ To unlock: Enter the release code.  The release code is "0" in the order configuration. Another release code can be defined in the " Code definition (023) " parameter. If the user has forgotten the release code, the release code can be visible by entering the number "5864". Factory setting: 0

The release code is defined in the "**Code definition (023)**" parameter.

Parameter name	Description
Code definition (023) Entry  Menu path: Setup → Extended setup → Code definition	Use this function to enter a release code with which the device can be unlocked. User input: <ul style="list-style-type: none"> ▪ A number between 0 and 9999 Factory setting: 0

6.3.6 Resetting to factory settings (reset)

By entering a certain code, you can completely, or partially, reset the entries for the parameters to the factory settings ("**Enter reset code (124)**"¹⁾). Enter the code by means of the "**Enter reset code (124)**" parameter (menu path: "Diagnosis" → "Reset" → "**Enter reset code (124)**").

There are various reset codes for the device. The following table illustrates which parameters are reset by the particular reset codes. Operation must be unlocked to reset parameters (→ [54](#)).



Any customer-specific configuration carried out at the factory is not affected by a reset (customer-specific configuration remains). If you want to change the customer-specific configuration carried out at the factory, please contact Endress+Hauser Service.

Reset code ¹⁾	Description and effect
62	PowerUp reset (warm start) <ul style="list-style-type: none"> ▶ The device is restarted. ▶ Data are read back anew from the EEPROM (processor is initialized again). ▶ Any simulation which may be running is ended.
333	User reset <ul style="list-style-type: none"> ▶ This code resets all the parameters apart from: <ul style="list-style-type: none"> - Device tag (022) - Operating hours (162) - Lo trim sensor (131) - Hi trim sensor (132) - Event logbook - Linearization table ▶ Any simulation which may be running is ended. ▶ The device is restarted.
7864	Total reset <ul style="list-style-type: none"> ▶ This code resets all the parameters apart from: <ul style="list-style-type: none"> - Operating hours (162) - Lo trim sensor (131) - Hi trim sensor (132) - Event logbook ▶ Any simulation which may be running is ended. ▶ The device is restarted.

1) To be entered in "Diagnosis" → "Reset" → "**Enter reset code (124)**"

1) The default value for the individual parameters is indicated in the parameter description (→ [127 ff](#))

6.4 PROFIBUS PA communication protocol

6.4.1 System architecture

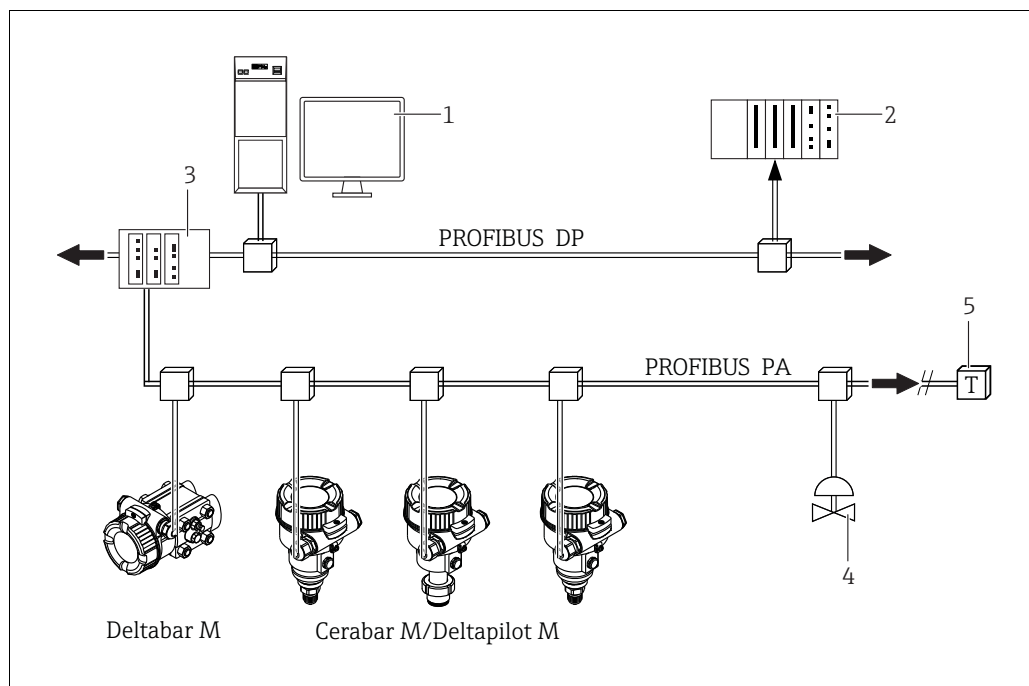

Fig. 26: PROFIBUS system architecture

- 1 PC with PROFIBUS interface card (Profiboard/Proficard) and FieldCare operating program (Class 2 master)
- 2 PLC (Class 1 master)
- 3 Segment coupler (DP/PA signal converter and bus power supply)
- 4 Additional devices and adjusters such as valves, for example
- 5 PROFIBUS PA terminating resistor



Further information on PROFIBUS PA is provided in the Operating Instructions BA00034S "PROFIBUS DP/PA: Guidelines for planning and commissioning", the PNO Guideline and the IEC 61158, IEC 61784, EN 50170/DIN 19245 and EN 50020 standards (FISCO model).

6.4.2 Number of devices

- Endress+Hauser devices meet the requirements specified by the FISCO model.
- Due to the low current consumption, the following can be operated at one bus segment when installation is performed according to FISCO
 - Up to 8 devices for EEx ia, CSA and FM IS applications
 - Up to 31 devices in all other applications, e.g. in non hazardous areas, EEx nA etc.

The maximum number of measuring devices at one bus segment is defined by their current consumption, the performance of the bus coupler, and the required bus length.

6.4.3 Operation

You can obtain special configuration and operating programs from various manufacturers for the configuration, such as the FieldCare operating program from Endress+Hauser (→ 54, "Operation via FieldCare"). This operating program makes it possible to configure the PROFIBUS PA and device-specific parameters. The predefined function blocks allow uniform access to network and device data.

6.4.4 Identification number of the device

The "Ident number sel (229)" parameter allows users to modify the identification number. The identification number (Ident number (Ident_Number)) must support the following settings:

Values for "Ident number sel"	Description
0 "0x9700"	Profile-specific identification number V3.02 with the "Classic" or "Condensed" status.
1 "0x1553", "0x1554", "0x1555"	Manufacturer-specific identification number (V3.02). Cerabar M, Deltabar M, Deltapilot M
127 "Auto. identification number (Auto.Id.Num.)"	Device adaptation mode (the device can communicate using a variety of identification numbers), see "Smart device management" (automatic smart device management).
128 "0x1503", "0x151C"	Manufacturer-specific identification number (V3.00). Deltapilot M, Cerabar M

The "Automatic Identification Number Selection" (value = 127) for Profile 3.02 is described in Section "Smart device management (automatic smart device management)".

The choice of identification number affects the status and diagnostic messages ("Classic" or "Condensed"). "Old" identification numbers work with the "Classic" status and old diagnostic messages.

New identification numbers only work with the "Condensed" status and new diagnostic messages.

Depending on the configuration data of the user or the behavior selected in the physical "Cond.status diag" block parameter, the profile identification number works with either the "Condensed" or "Classic" status.

The identification number can only be changed if no cyclic communication is taking place with the device.

Cyclic data transmission and the corresponding identification number of the device remain the same until cyclic transmission is aborted and reestablished or the device is shut down.

When reestablishing cyclic data transmission the device uses the last value of the "Ident number sel" parameter.

The choice of identification number also determines how many modules are assigned during cyclic communication. All blocks are internally instantiated in advance for all the devices but only the configured modules can be accessed depending on the entries in the device master data.

Table of the function blocks:

"Ident number sel" parameter	0 (Profile-specific)	128 (Old identification number)	127 (Auto. identification number)	1 (New identification number)
Cerabar M / Deltapilot M	3 blocks (PB,TB,AI)	3 blocks (PB,TB,AI)	Depends on the identification number automatically selected.	6 blocks (PB,TB,AI1, AI2,DAO_EH1, DAO_EH2)
	1 module (1xAI)	3 modules (2xAI, 1xAO)		4 modules (2xAI, 2xDAO_EH)
Deltabar M	3 blocks (PB,TB,AI)	...	Depends on the identification number automatically selected.	7 blocks (PB,TB,AI1, AI2,DAO_EH1,DAO_EH2,TOT)
	1 module (1xAI)	...		5 modules (2xAI, 2xDAO_EH, 1xTOT)



If the device is configured with an old identification number (0x151C), then it automatically switches to the pressure measurement mode (Pressure). The level measuring mode (Level) is not supported in an old pressure measuring device of the Cerabar M series (0x151C).

Table of the identification numbers:

Value for "Ident number sel"	Identification number			Selection text			Status	Diagnosis
	Cerabar M	Deltabar M	Deltapilot M	Cerabar M	Deltabar M	Deltapilot M		
0 (Profile-specific 3.x)	0x9700	0x9700	0x9700	0x9700	0x9700	0x9700	Classic status / Condensed status	Old diagnostic messages / New diagnostic messages
128 (Old identification number)	0x151C	...	0x1503	0x151C	...	0x1503	Classic status	Old diagnostic messages
127 (Adaptation mode)	0x1553 / 0x151C/ 0x9700	0x1554 / 0x9700	0x1555 / 0x1503/ 0x9700	Auto. identificatio n number	Auto. identificatio n number	Auto. identificatio n number	Depends on ident numbers	Depends on ident numbers
1 (New identification number)	0x1553	0x1554	0x1555	0x1553	0x1554	0x1555	Condensed status	New diagnostic messages

Smart device management (automatic smart device management)

Smart PA device management is performed by automatically adapting the device identification number. This makes it possible to replace old devices with new models without having to modify the PLC, allowing the transition from an installed device technology to a more sophisticated technology without interrupting the process.

With the "Automatic Identification Number Selection" option, the device behavior and rules (diagnostics, cyclic communication etc.) remain the same as those for a static identification number. The identification number is selected automatically depending on the recognized request frame -"Set Slave Parameter" or "Set Slave Address".

It is permitted to change the identification number in two specific device transition states, namely after Set Slave Address (SAP 55) and after Set Slave Parameter (SAP 61), and only if the identification number is listed in the table above.

If the identification number is undefined and the selector is set to "automatic", following a "Get Slave Diagnose" frame the device returns an identification number diagnostic value which is compatible with the device. After every new "Get Slave Diagnose" frame, the device returns another identification number that is compatible with the device until the PLC sends a "Set Slave Address" or "Set Slave Parameter" frame with a known identification number.

6.4.5 Device identification and addressing

Please note the following:

- An address must be assigned to each PROFIBUS PA device. The control system/master can only recognize the device if the address is set correctly.
- Each address can only be assigned once in any PROFIBUS PA network.
- Device addresses in the range from 0 to 125 are valid.
- The address "126" configured at the factory can be used for functional device testing and to connect to a PROFIBUS PA network already in operation. This address must be changed subsequently to add additional devices.
- On leaving the factory, all devices are delivered with the default address 126 and software addressing.
- The FieldCare operating program is delivered with the default address 1.

There are two ways to assign the device address to a Cerabar/Deltabar/Deltapilot:

- Via an operating program of the DP Class 2 master, such as FieldCare or
- Onsite via DIP switches.

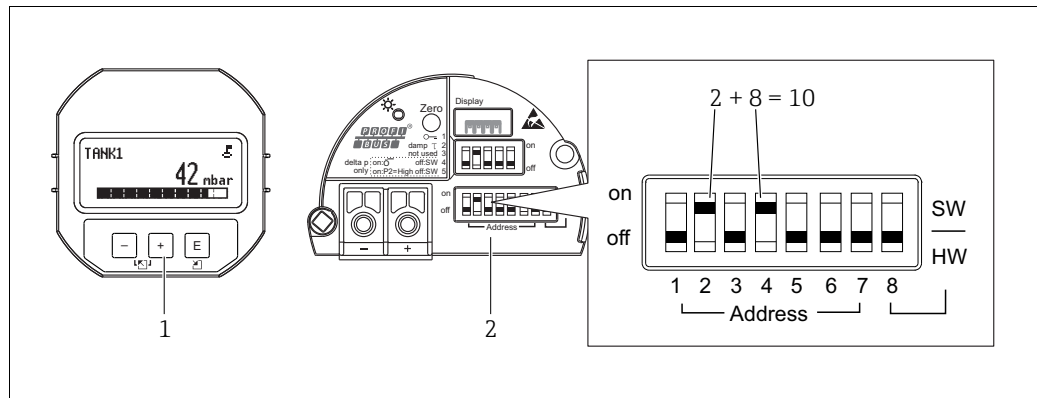

Fig. 27: Setting the device address via DIP switches

- 1 If necessary, remove onsite display (optional)
- 2 Set the hardware address via the DIP switches

Hardware addressing

A hardware address is set as follows:

1. Set the DIP switch 8 (SW/HW) to "Off".
2. Set the address with DIP switches 1 to 7.
3. The change of address takes effect after 10 seconds. The device is restarted.

DIP switch	1	2	3	4	5	6	7
Value when set to "On"	1	2	4	8	16	32	64
Value when set to "Off"	0	0	0	0	0	0	0

Software addressing

A software address is set as follows:

1. Set the DIP switch 8 (SW/HW) to "On" (factory setting).
2. The device is restarted.
3. The device reports its current address. Factory setting: 126
4. Set the address via the configuration program.
See the next section for information on how to enter a new address via FieldCare.
For other operating programs, see the corresponding operating manual.

Setting a new address via FieldCare. DIP switch 8 (SW/HW) is set to "On" (SW):

1. Select the Profibus DP communication DTM "PROFIdtm DPV1" via the menu "Device operation" → "Add device".
2. Click the mouse once to select the Profibus DP communication DTM and via the "Tools" menu, select → "Scanning tools" → "Create network". The network is scanned and a device previously connected reports with an active address (e.g. 126: default address).
3. The device must be disconnected from the bus to be able to assign a new address to the device. For this purpose, go to the "Device operation" menu and select "Disconnect".
4. Click the mouse once to select the Profibus DP communication DTM and via the "Device operation" menu, select → "Device functions" → "Additional functions" → "Set device station address". The "ProfiDTM DPV1 (Set device station address)" screen is displayed. Enter the old and new address and select "Set" to confirm. The new address is assigned to the device.
5. Click the mouse once to select the Profibus DP communication DTM and via the "Device operation" menu, select → "Device functions" → "Additional functions" → "Edit DTM station addresses...". The "PROFIdtm DPV1 (Edit DTM station addresses...)" screen is displayed. Enter the device address previously configured and select "Apply" to confirm. The new address is assigned to the device.
6. Click the mouse once to select the device DTM. The device is operated online via "Device operation" → "Connect".

6.4.6 System integration

Device master data (GSD files)

The device is ready for system integration following commissioning via the Class 2 master (FieldCare). To integrate the field devices into the bus system, the PROFIBUS PA system requires a description of the device, such as the device ID, identification number (Ident_Number), supported communication features, module structure (combination of cyclic input/output telegrams) and the meaning of the diagnostic bits.

These data are found in a device master file (GSD file) which is made available to the PROFIBUS DP master (e.g. PLC) when the communication system is being commissioned. In addition, it is also possible to integrate device bit maps which appear as icons in the network tree structure.

The following versions of the GSD are possible when using devices that support the "PA devices" profile:

- Deltapilot M:
 - Manufacturer-specific GSD, identification number (Ident_Number): 0x1555:
This GSD ensures the complete and unrestricted functionality of the field device. All the device-specific process parameters and functions are available.
 - Manufacturer-specific GSD, identification number: 0x1503:
The device behaves like a Deltapilot S DB50, DB50L, DB51, DB52, DB53.
→ See Operating Instructions BA00164F.
- Deltabar M:
 - Manufacturer-specific GSD, identification number (Ident_Number): 0x1554:
This GSD ensures the complete and unrestricted functionality of the field device. All the device-specific process parameters and functions are available.
- Cerabar M:
 - Manufacturer-specific GSD, identification number (Ident_Number): 0x1553:
This GSD ensures the complete and unrestricted functionality of the field device. All the device-specific process parameters and functions are available.
 - Manufacturer-specific GSD, identification number: 0x15C1:
The device behaves like a Cerabar M PMC41, PMC45, PMP41, PMP45, PMP46, PMP48.
→ See Operating Instructions BA00222P.
- Profile GSD:

As an alternative to the manufacturer-specific GSD, the PNO makes available a general database file called PA139700.gsd for devices with an Analog Input Block. This file supports transmission of the primary value. The transmission of a 2nd cyclic value or a display value is not supported. If a system is commissioned with the profile GSDs, devices of different manufacturers can be exchanged.

The following device master files (GSD) can be used:

Name of the device	Comments	Identification number (Ident_Number) ¹⁾	GSD	Type file	Bitmap
All	Profile GSD	0x9700	PA139700.gsd		
Deltapilot M PROFIBUS PA	Device-specific GSD	0x1555 ²⁾	EH3x1555.gsd		EH_1555_d.bmp/.dib EH_1555_n.bmp/.dib EH_1555_s.bmp/.dip
	Device-specific GSD. The device behaves like a Deltapilot S DB50, DB50L, DB51, DB52, DB53. → See Operating Instructions BA00164F.	0x1503 ²⁾	EH3_1503.gsd EH3x1503.gsd	EH31503x.200	EH_1503_d.bmp/.dib EH_1503_n.bmp/.dib EH_1503_s.bmp/.dip
Deltabar M PROFIBUS PA	Device-specific GSD	0x1554 ²⁾	EH3x1554.gsd		EH_1554_d.bmp/.dib EH_1554_n.bmp/.dib EH_1554_s.bmp/.dip
Cerabar M PROFIBUS PA	Device-specific GSD	0x1553 ²⁾	EH3x1553.gsd		EH_1553_d.bmp/.dib EH_1553_n.bmp/.dib EH_1553_s.bmp/.dip
	Device-specific GSD. The device behaves like a Cerabar M PMC41, PMC45, PMP41, PMP45, PMP46, PMP48. → See Operating Instructions BA00222P.	0x151C ²⁾	EH3_151C.gsd EH3x151C.gsd	EH3151Cx.200	EH_151C_d.bmp/.dib EH_151C_n.bmp/.dib EH_151C_s.bmp/.dip

- 1) Use the "Ident number sel" parameter to select the appropriate identification number
Menu path in FieldCare/onsite display: Setup → Extended setup or Expert → Communication → PB-PA config
- 2) Each device is given an identification number by the PROFIBUS user organization (PNO). The name of the GSD file is derived from this number. For Endress+Hauser, this identification number begins with the manufacturer ID "15xx".

The factory setting for the "Ident number sel" parameter is "Auto.Id.Num" (adaptation mode). The adaptation mode allows automatic identification/integration into the control system. The "Ident number sel" parameter can only be changed if the device is not included in cyclic communication (not commissioned in the PLC) or if cyclic communication of the PLC is set to "Stop". If an attempt is nevertheless made to change the parameter via a configuration software program, such as FieldCare, the entry is ignored.

The device master data (GSD files) for Endress+Hauser devices can be acquired as follows:

- Internet Endress+Hauser: <http://www.de.endress.com> → Download → Search for "GSD"
- Internet PNO: <http://www.profibus.com> (Products – Product Guide)
- On CD-ROM from Endress+Hauser, order number: 56003894

The profile device master data (GSD files) of the PNO can be acquired as follows:

- Internet PNO: <http://www.profibus.com> (Products – Profile GSD Library)

Directory tree of the GSD files for Endress+Hauser

All the data required to commission Endress+Hauser field devices with a PROFIBUS PA interface are contained in a single compressed file. Once unpacked, this file has the following structure:

Cerabar_M/PA/Profile3/Revision1.0/	→ BMP/	→ Eh1553_d.bmp Eh1553_n.bmp Eh1553_s.bmp
	→ DIB/	→ Eh1553_d.dib Eh1553_n.dib Eh1553_s.dib
	→ GSD/	→ Eh3x1553.gsd
	→ Info/	→ Liesmich.pdf Readme.pdf
Deltabar_M/PA/Profile3/Revision1.0/	→ BMP/	→ Eh1554_d.bmp Eh1554_n.bmp Eh1554_s.bmp
	→ DIB/	→ Eh1554_d.dib Eh1554_n.dib Eh1554_s.dib
	→ GSD/	→ Eh3x1554.gsd
	→ Info/	→ Liesmich.pdf Readme.pdf
Deltapilot_M/PA/Profile3/Revision1.0/	→ BMP/	→ Eh1555_d.bmp Eh1555_n.bmp Eh1555_s.bmp
	→ DIB/	→ Eh1555_d.dib Eh1555_n.dib Eh1555_s.dib
	→ GSD/	→ Eh3x1555.gsd
	→ Info/	→ Liesmich.pdf Readme.pdf

- Revision x.x stands for the specific device version.
- The "Info" folder contains information on implementing the field transmitters and any dependencies in the device software. Read this information carefully before commissioning.
- The "BMP" and "DIB" folders contain device-specific bitmaps which can be used depending on the configuration software.

Working with the device master data (GSD files)

The device master data (GSD files) must be integrated into a specific subdirectory of the PROFIBUS DP configuration software of the PLC used. Depending on the software used, these data can be either copied to the program-specific directory or imported into the database using an import function in the configuration software.

More information on the directories to which the device master data (GSD files) are to be saved is provided in the description of the specific configuration software used.

6.4.7 Cyclic data exchange

Block model

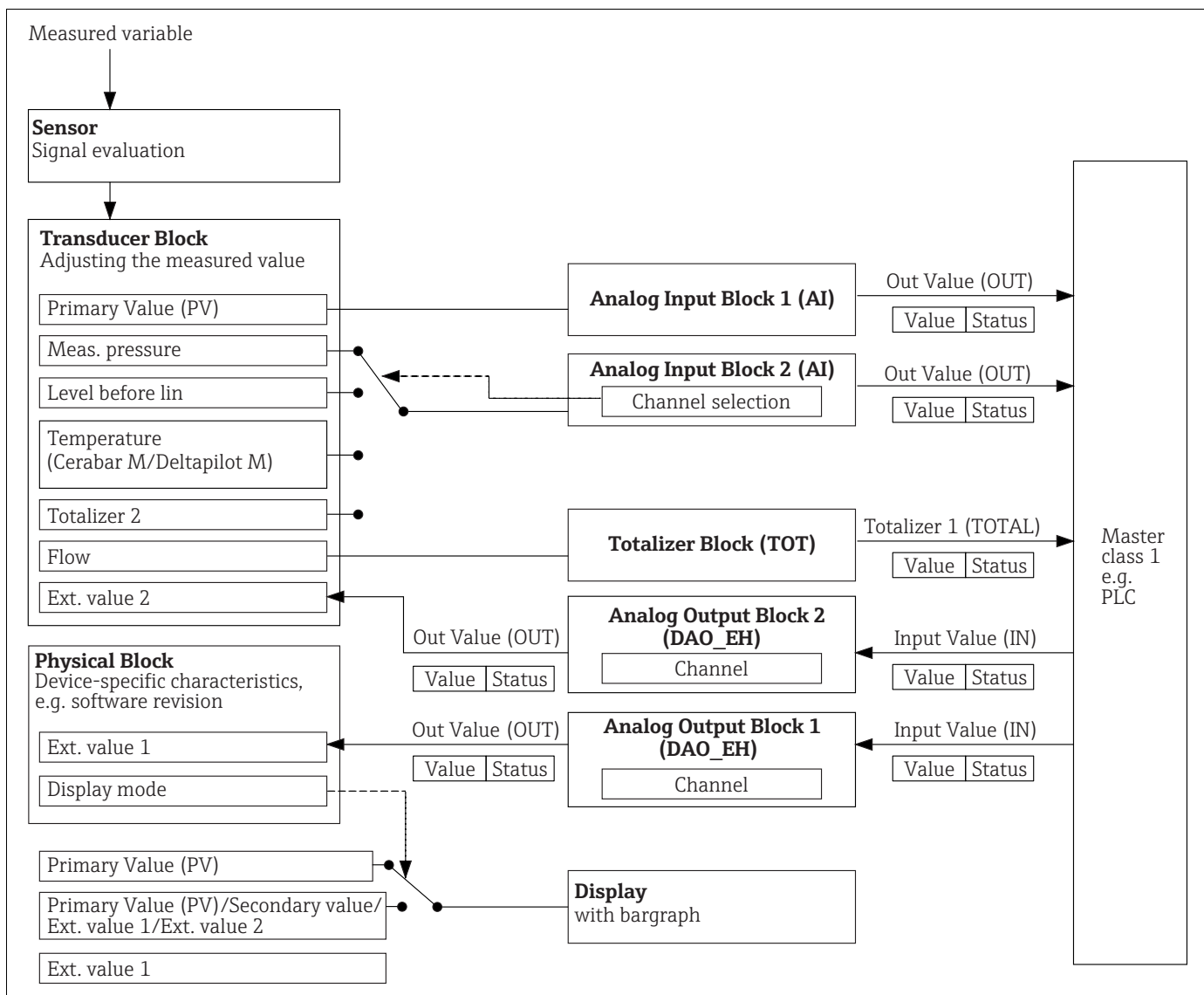

Fig. 28: The block model shows what data can be transmitted between the measuring device and the Class 1 master (e.g. PLC) during cyclic data exchange. Using the configuration software of your PLC, you can configure the cyclic data telegram via modules (→ see also this chapter, "Modules for the cyclic data diagram" section). The parameters written in upper-case are parameters in the operating program (e.g. PLC) via which you can make settings for the cyclic data telegram or show values on the screen (→ see also this chapter, "Description of parameters" section).

Function blocks

PROFIBUS uses predefined function blocks to describe the function blocks of a device and to define standard data access.

The following blocks are implemented:

- Physical Block:
The Physical Block contains device-specific features such as the device type, manufacturer, version etc. as well as functions such as write protection management and identification number changeover (Ident_Number)
- Transducer Block:
The Transducer Block contains all the measuring and device-specific parameters of the device.
 - Cerabar M and Deltapilot M:
The Transducer Block contains the pressure measuring principle for use as a pressure and level transmitter.
 - Deltabar M:
The Transducer Block contains the differential pressure measuring principle for use as a pressure, flow and level transmitter.
- Analog Input Block (function block):
The Analog Input Block contains the signal processing functions of the measured value, such as scaling, special function calculations, simulation etc.
The following graphic illustrates the structure of the standard Analog Input Block:

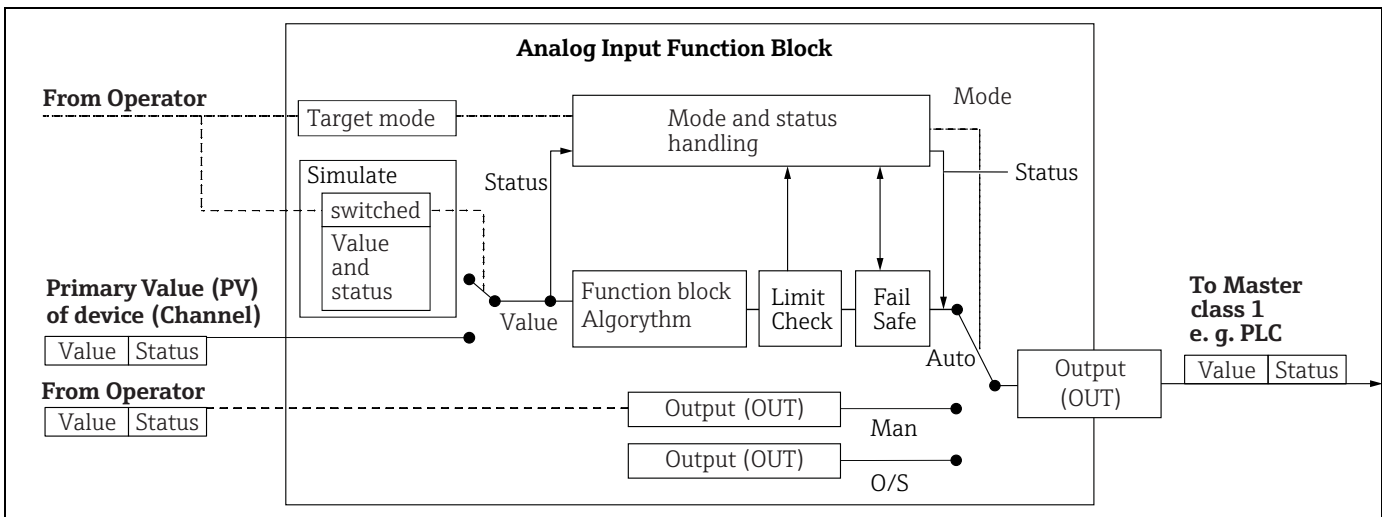

- Totalizer Block (function block) (Deltabar M):
The Totalizer Block contains the signal processing functions of the measured value to be totalized, such as flow, scaling, special function calculations, simulation etc.
The following graphic illustrates the structure of the standard Totalizer Block:

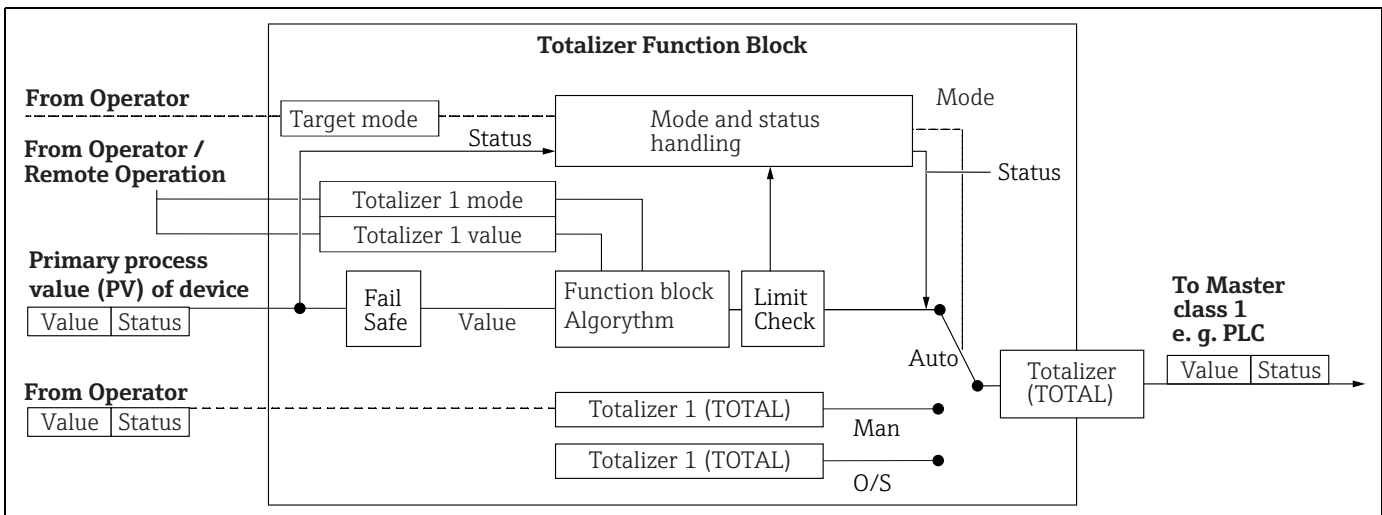

- Analog Output Block (function block)**
 The DAO_EH Block is an Analog Output Block specific to Endress+Hauser which is used to transmit external values from the PLC to the device and show them on the display. The block contains the signal processing functions that process the external value (IN) into the output value (Out Value).
 The following graphic illustrates the structure of the Endress+Hauser-specific Analog Output Block:

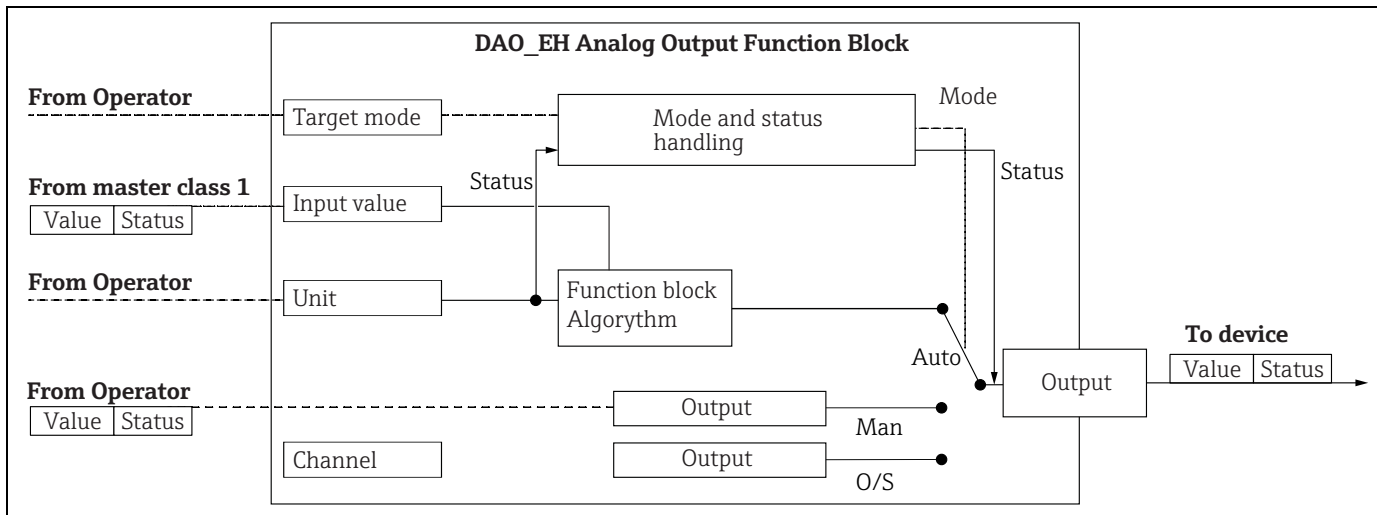

Description of parameters

Parameter name	Description
Output value (Out Value) (Analog Input Block 1)	This parameter displays the digital Output value (Out Value) of the Analog Input Block 1. The channel selection (channel entry) is permanently linked to the primary value. Menu path in FieldCare: Expert → Communication → Analog input 1 → AI parameter Menu path for onsite display: Expert → Communication → Analog input 1
Output value (Out Value) (Analog Input Block 2)	This parameter displays the digital Output value (Out Value) of the Analog Input Block. The following device measured values are linked via the channel entry. In the case of Cerabar M and Deltapilot M: "Meas. pressure", "Level before lin" and temperature In the case of Deltabar M: "Meas. pressure", "Level before lin", and totalizer 1 Menu path in FieldCare: Expert → Communication → Analog input 2 → AI parameter Menu path for onsite display: Expert → Communication → Analog input 2
Totalizer 1 (Totalizer Block) (Deltabar M)	This parameter displays the digital Output value (Out Value) of the Totalizer Block. The channel selection (channel entry) is permanently linked to the flow measured value. Menu path in FieldCare: Expert → Communication → Totalizer 1 → TOT parameter Menu path for onsite display: Expert → Communication → Totalizer 1
Input value (IN Value) (Analog Output Block 1)	The PLC sends this value to the device. The channel selection (channel) is permanently linked to the Ext. value 1. The "Ext. value 1" can be displayed on the onsite display (see this table, Display mode). Menu path in FieldCare: Expert → Communication → Analog output 1 → AO parameter Expert → Communication → Physical Block → PB parameter → Display value Menu path for onsite display: Expert → Communication → Analog output 1

Parameter name	Description
Input Value (IN Value) (Analog Output 2)	<p>The PLC sends this value to the device. The channel selection (channel) is permanently linked to the Ext. value 2. The "Ext. value 2" can be shown on the onsite display (see this table, Display mode). This channel is used by Cerabar M and Deltapilot M to display and/or transmit the calculated electrical differential pressure. In the case of Deltabar M, it is used for display purposes only (external temperature, top pressure). Menu path in FieldCare: Expert → Communication → Analog output 2 → AO parameter Menu path for onsite display: Expert → Communication → Analog output 2 Menu path for onsite display: and FieldCare Expert → Application</p>
Display mode	<p>Use this parameter to specify whether the main value or the Ext. value 1 should be displayed or whether the display should alternate between these values and the Ext. value 2. The appropriate modules (DAO_EH) must be cyclically configured to display the external values from the PLC in alternating mode. Menu path in FieldCare: Display/operat. Menu path for onsite display: Display/operat.</p> <p>Options:</p> <ul style="list-style-type: none"> ■ Main value only: the main value is shown on the onsite display. ■ Ext. value 1 only: a value from the PLC is shown on the onsite display (see →  28). ■ All alternating: the display alternates between the main value, Ext. value 1 and Ext. value 2. A value previously configured via "Add. disp. value" also alternates with the other values on the display. <p>Deltapilot M/Cerabar M example for the "Ext. value 1" option:</p> <ul style="list-style-type: none"> ■ Two Deltapilot M or two Cerabar M devices measure the drop in pressure over a filter. The differential pressure is calculated in the PLC. Using the "Ext. value 1" option, assign this calculated value to the onsite display. <p>Deltabar M example for the "Ext. value 1" option:</p> <ul style="list-style-type: none"> ■ One Deltabar M device measures a volume flow. The temperature and the pressure are also measured simultaneously at the measuring point. All these measured values are fed to a PLC. The PLC calculates the steam mass from the volume flow, temperature and pressure measured values. Using the "Ext. value 1" option, assign this calculated value to the onsite display. <p>Factory setting:</p> <ul style="list-style-type: none"> ■ Main value only

Modules for the cyclic data diagram

The following modules are available in the measuring device for the cyclic data diagram:

- Output value (Out Value) (Analog Input Block 1)
Depending on the measuring mode selected, a pressure, flow or level value is transmitted here.
- Output value (Out Value) (Analog Input Block 2)
Depending on the option selected, the measured pressure, level before linearization, sensor temperature or a totalizer 2 value is transmitted here.
- Totalizer 1 (Totalizer Block) (Deltabar M)
Depending on the flow measuring mode selected, the totalizer 1 value is transmitted here.
- Input value (IN Value) (Analog Output Block 1)
This can be any value which is transmitted by the PLC to the device. This value can also be shown on the onsite display (Ext. value 1).
- Input value (IN Value) (Analog Output Block 2)
This can be any value which is transmitted by the PLC to the device. This value can also alternate with another value on the onsite display (Ext. value 2) or be used to calculate the differential pressure.
- FREE PLACE
Select this empty module if a value should not be used in the data telegram.

Structure of the output data PLC

Using the Data_Exchange service, a PLC can write output data to the device in the call telegram. The cyclic data telegram has the following structure:

Index	Output data	Data access	Data format/comments
0, 1, 2, 3	Input value (IN Value) (Analog Output 1)	Write	32 bit floating point number (IEEE 754)
4	Input status (IN Status) (Analog Output 1)	Write	→ See "Status codes" section
5, 6, 7, 8	Input value (IN Value) (Analog Output 2)	Write	32 bit floating point number (IEEE 754)
9	Input status (IN Status) (Analog Output 2)	Write	→ See "Status codes" section

Structure of the input data measuring device - PLC

Using the Data_Exchange service, a PLC can read input data from the device in the response telegram. The cyclic data telegram has the following structure:

Index	Input data	Data access	Data format/comments
0, 1, 2, 3	Output value (Out Value) (Analog Input 1)	Read	32 bit floating point number (IEEE 754)
4	Output status (Out Status) (Analog Input 1)	Read	→ See "Status codes" section
5, 6, 7, 8	Output value (Out Value) (Analog Input 2)	Read	32 bit floating point number (IEEE 754)
9	Output status (Out Status) (Analog Input 2)	Read	→ See "Status codes" section
10, 11, 12, 13	Totalizer 1 value (Totalizer) (Deltabar M)	Read	32 bit floating point number (IEEE 754)
14	Totalizer 1 status (Totalizer) (Deltabar M)	Read	→ See "Status codes" section

Status codes

The Cerabar M, Deltapilot M and Deltabar M devices support the "Condensed Status" function as defined in the PNO specification. However, the "Classic" status is also supported to ensure compatibility with older devices in the M series and due to the profile-specific identification number (Profile Specific Ident. Number).

The status type is selected depending on the device identification number:

- The "Classic" status is enabled if the identification number (Ident number) is set to 0x151C (Cerabar M PMC4x, PMP4x) / 0x1503 (Deltapilot S DB5x) / 0x9700 (specific identification number for Profile 3.x).
- The "Condensed" status is enabled if the identification number (Ident number) is set to 0x1553 (Cerabar M s1)/0x1554 (Deltabar M s1) /0x1555 (Deltapilot M s1) / 0x9700 (specific identification number for Profile 3.02).

If the profile identification number is selected, the status type can be set via the "Cond.status diag" parameter.

The "Condensed" and/or "Classic" status and their current active states are displayed by the "Physical Block" in the "Feature" parameter.

The measuring device supports the following status codes for the Output value parameters of the Analog Input Blocks and the Totalizer Block:

Classic status

Status code	Device state	Meaning	Output value (Out Value) (Analog Input 1)	Output value (Out Value) (Analog Input 2)	Totalizer 1 (Totalizer (Deltabar M))
0000 0000	BAD	Not specific	X ¹⁾	X ¹⁾	-
0000 0100	BAD	Configuration error (e.g. adjustment not performed correctly)	X ¹⁾	X ¹⁾	X
0000 1100	BAD	Device error	X ¹⁾	X ¹⁾	X
0001 0000	BAD	Sensor error	X ¹⁾	X ¹⁾	-
0001 1100	BAD	Out of service (Target mode)	X	X	X
0100 0000	UNCERTAIN	Not specific	X	X	X
0100 0100	UNCERTAIN	Last valid value (Fail safe mode = 1)	X	X	X
0100 1000	UNCERTAIN	Substitute value (Fail safe mode = 0)	X	X	X
0100 1100	UNCERTAIN	Initial value (Fail safe mode = 1)	X	X	X
0101 1000	UNCERTAIN	Abnormal	X	X	X
0101 1100	UNCERTAIN	Configuration error (e.g. linearization table not monotonic increasing)	X	X	X
0101 0011	UNCERTAIN	Sensor calibration - constant	X	X	X
0101 0010	UNCERTAIN	Sensor calibration - limit value exceeded	X	X	X
0101 0010	UNCERTAIN	Sensor calibration - limit value undershot	X	X	X
0101 0000	UNCERTAIN	Sensor calibration	X	X	X
0110 0000	UNCERTAIN	Simulation value	X	X	X
1000 0000	GOOD	Good	X	X	X
1000 1000	GOOD	Warning limit	X	X	X
1000 1001	GOOD	Warning limit - limit value exceeded	X	X	X
1000 1010	GOOD	Warning limit - limit value undershot	X	X	X
1000 1100	GOOD	Alarm limit	X	X	X
1000 1101	GOOD	Alarm limit - limit value exceeded	X	X	X
1000 1110	GOOD	Alarm limit - limit value undershot	X	X	X

1) Only if the analog input failure behavior = 2 ("Status BAD")

Condensed status

The main reason for implementing the "Condensed" status mode in the Profibus PA Profile 3.02 is to clarify the diagnostic events resulting from use in the PCS/DCS and in the operating station.

Furthermore, this functionality also implements the requirements of NE 107.

The following "Condensed" status codes are configured via the device.

Status code ¹⁾	Device state	Meaning	Output value (Out Value) (Analog Input 1)	Output value (Out Value) (Analog Input 2)	Totalizer 1 (Totalizer (Deltabar M))
0010 01xx	BAD ²⁾	Maintenance alarm, advanced diagnostics present	X	X	X
0010 10xx	BAD ²⁾	Process error, no maintenance required	X ³⁾	X ³⁾	X ⁴⁾
0011 11xx	BAD ²⁾	Function check / local override	X ³⁾	X ³⁾	X
0010 0011	BAD ²⁾	Switch off	X	X	X
0111 1011	UNCERTAIN	Process error, no maintenance required - limit value constant	X	X	X
0111 1010	UNCERTAIN	Process error, no maintenance required - limit value exceeded	X	X	X
0111 1001	UNCERTAIN	Process error, no maintenance required - limit value undershot	X	X	X
0111 1000	UNCERTAIN	Process error, no maintenance required	X	X	X
0110 10xx	UNCERTAIN	Maintenance required	X	X	X
0100 1011	UNCERTAIN	Substitute value	X	X	X
0100 1111	UNCERTAIN	Initial value			X
0111 0011	UNCERTAIN	Simulated value, start	X	X	X
0111 0100	UNCERTAIN	Simulated value, end	X	X	X
1000 0000	GOOD	Good	X	X	X
1011 1100	GOOD	Function check	X	X	X

1) Variable x: 0 or 1

2) See → Chap. 11.2.1

3) Only if the analog input failure behavior = 2 ("Status BAD")

4) Only if the "Total. 1 failsafe" parameter is set to 1 ("Hold") or 0 ("Run")

6.4.8 Acyclic data exchange

Acyclic data exchange is used:

- To transmit commissioning or maintenance parameters
- To display measured variables that are not part of the cyclic data diagram.

Using the acyclic data exchange function, device parameters can be modified even when the device is involved in cyclic data exchange with a PLC.

There are two kinds of acyclic data exchange:

- Acyclic communication via the C2 channel (MS2)
- Acyclic communication via the C1 channel (MS1)

Acyclic communication via the C2 channel (MS2)

During communication via the C2 channel, a master opens a communication channel via a service access point (SAP) in order to access the device. A master that supports acyclic communication via the C2 channel is known as a Class 2 master. FieldCare, for example, is a Class 2 master.

All the device parameters must be made known to the master before data can be exchanged via PROFIBUS.

The following options are available here:

- A configuration program in the master which accesses the parameters via slot and index addresses (e.g. FieldCare)
- A software component (DTM: device type manager)

The DTM can be found on the FieldCare CD.

Restrictions:

- The number of SAPs available will determine the number of Class 2 masters that can simultaneously communicate with a device. The device supports MS2 communication with two SAPs. Ensure that multiple masters do not write-access the same data as the consistency of the data cannot be guaranteed if this occurs.
- The use of the C2 channel for acyclic data exchange increases the cycle times of the bus system. This must be taken into account when programming the control system or controller.

Acyclic communication via the C1 channel (MS1)

During acyclic communication via the C1 channel, a master which is already communicating cyclically with the device opens an additional acyclic communication channel via the SAP 0x33 (special SAP for MS1). It can then acyclically read or write the parameters via the slot and index addresses like a Class 2 master.

The device supports MS1 communication with one SAP.

NOTICE

The memory modules are only designed for a limited number of writes.

Parameters written acyclically are saved as persistent data to the memory modules (e.g. EEPROM, Flash). The memory modules are only designed for a limited number of writes. The device does not even come close to reaching this maximum number of writes during normal operation without MS1 (during configuration). However, this number can be quickly exceeded if the device is incorrectly programmed. This reduces the service life of the device dramatically.

- ▶ In the application program, avoid permanently writing parameters, such as for every program cycle.

6.4.9 Slot/index tables

The device parameters are listed in the following tables. The parameters can be accessed via the slot and index numbers. The individual blocks each contain standard parameters, block parameters and manufacturer-specific parameters.

If you use FieldCare as the operating program, input screens are available as the user interface.

General explanatory remarks

Object type

- Record: contains data structures (DS)
- Array: group of a specific data type
- Simple: contains individual data types, e.g. Float

Data type

- DS: data structure, contains data types such as Unsigned8, OctetString etc.
- Float: IEEE 754 format
- Integer:
 - Integer8: value range = -128 to 127
 - Integer16: value range = -32768 to 32767
 - Integer32: value range = $-2^{31} \dots (2^{31}-1)$
- OctetString: binary encoded
- VisibleString: ASCII encoded
- Unsigned:
 - Unsigned8: value range = 0 to 255
 - Unsigned16: value range = 0 to 65535
 - Unsigned32: value range = 0 to 4294967295

Storage Class

- Cst: constant parameter
- D: dynamic parameter
- N: nonvolatile parameter
- S: static parameter

Physical Block

Parameter	Slot	Index	Object type	Data type	Size (Byte)	Storage Class	Read	Write	Page
Physical Block Standard Parameters									
Block object	0	16	Record	DS-32	20	Cst	x		→ 155
Static rev. no.	0	17	Simple	Unsigned16	2	N	x		→ 155
TAG	0	18	Simple	VisibleString	32	S	x	x	→ 155
Strategy	0	19	Simple	Unsigned16	2	S	x	x	→ 156
Alert key	0	20	Simple	Unsigned8	1	S	x	x	→ 156
Target mode	0	21	Simple	Unsigned8	1	S	x	x	→ 156
Block mode	0	22	Record	DS-37	3	D	x		→ 156
Alarm summary	0	23	Record	DS-42	8	D	x		→ 156
Firmware version	0	24	Simple	VisibleString	16	Cst	x		→ 156
Hardware Rev.	0	25	Simple	VisibleString	16	Cst	x		→ 156
Manufacturer ID	0	26	Simple	Unsigned16	2	Cst	x		→ 156
Device name str.	0	27	Simple	VisibleString	16	Cst	x		→ 157
Serial number	0	28	Simple	VisibleString	16	Cst	x		→ 157
Diagnosis	0	29	Simple	Unsigned32	4	D	x		→ 157
Diag extension	0	30	Simple	OctetString	6	D	x		→ 157
Diag mask	0	31	Simple	OctetString	4	Cst	x		→ 157
Diag mask Ex	0	32	Simple	OctetString	6	Cst	x		→ 157
Dev. certificat.	0	33	Simple	VisibleString	32	Cst	x		→ 157
Write locking	0	34	Simple	Unsigned16	2	N	x	x	→ 158
Enter reset code	0	35	Simple	Unsigned16	2	S	x	x	→ 158
Additional info.	0	36	Simple	OctetString	32	S	x	x	→ 158
Message	0	37	Simple	OctetString	32	S	x	x	→ 158
Install. date	0	38	Simple	OctetString	16	S	x	x	→ 158
Ident number sel	0	40	Simple	Unsigned8	1	S	x	x	→ 158
Lock switch	0	41	Simple	Unsigned8	1	D	x		→ 158

Parameter	Slot	Index	Object type	Data type	Size (Byte)	Storage Class	Read	Write	Page
Feature	0	42	Record	DS-68	8	N	x		→ 159
Cond.status diag	0	43	Simple	Unsigned8	1	S	x	x	→ 159
Physical Block Endress+Hauser Parameters									
Diagnostic code	0	54	Record	Endress+Hauser-specific	5	D	x		→ 159
Last diag. code	0	55	Record	Endress+Hauser-specific	5	D	x		→ 159
Bus address	0	59	Simple	Unsigned8	1	D	x		→ 159
Set unit to bus	0	61	Simple	Unsigned8	1	S	x	x	→ 159
Ext. value 1	0	62	Record	Endress+Hauser-specific	6	D	x	x	→ 160
Profile revision	0	64	Simple	VisibleString	32	Cst	x		→ 160
Reset logbook	0	65	Simple	Unsigned8	1	S	x	x	→ 160
Ident number (Ident_Number)	0	66	Simple	Unsigned16	2	D	x		→ 160
Check conf.	0	67	Simple	Unsigned8	1	D	x		→ 160
Order number	0	69	Simple	VisibleString	32	Cst	x		→ 160
Tag location	0	70	Simple	VisibleString	22	Cst	x	x	→ 160
Signature	0	71	Simple	OctetString	54	Cst	x	x	→ 161
ENP version	0	72	Simple	VisibleString	16	Cst	x		→ 161
Device diag.	0	73	Simple	OctetString	48	D	x		→ 161
Ext. order code	0	74	Simple	VisibleString	60	Cst	x		→ 161
Service locking	0	75	Simple	Unsigned16	2	D	x	x	→ 161
Up/Dl feature	0	76	Simple	Unsigned16	2	Cst	x		→ 161
Updl control	0	77	Simple	Unsigned8	1	D	x	x	→ 161
Updl status	0	78	Simple	Unsigned8	1	N	x		→ 161
Updl veri delay	0	79	Simple	Unsigned16	2	N	x		→ 161
Up/Dl rev	0	80	Simple	Unsigned16	2	Cst	x		→ 161
Config. counter	0	89	Simple	Unsigned16	2	D	x		→ 161
Operating hours	0	90	Simple	Unsigned32	4	D	x		→ 161
Sim. error no.	0	91	Simple	Unsigned16	2	D	x	x	→ 162
Sim. messages	0	92	Simple	Unsigned8	1	D	x	x	→ 162
Language	0	93	Simple	Unsigned8	1	N	x	x	→ 162
Device name str.	0	94	Simple	Unsigned8	1	Cst	x		→ 162
Display mode	0	95	Simple	Unsigned8	1	N	x	x	→ 162
Add. disp. value	0	96	Simple	Unsigned8	1	N	x	x	→ 162
Format 1st value	0	97	Simple	Unsigned8	1	N	x	x	→ 162
Format 1st value	0	98	Simple	Unsigned8	1	N	x		→ 163
Status (Device Status)	0	99	Simple	Unsigned8	1	D	x		→ 163
Format ext. val. 2	0	100	Simple	Unsigned8	1	N	x	x	→ 163
Advanced diagnostics 7 (Diag add ext.)	0	101	Record	OctetString	6	D	x		→ 163
Diag mask add ext.	0	102	Record	OctetString	6	Cst	x		→ 163
Electr. serial no.	0	103	Simple	VisibleString	16	Cst	x		→ 163
Diagnostic code	0	104	Simple	Array	20	D	x		→ 163
Sw build nr.	0	105	Simple	Unsigned16	2	Cst	x		→ 163
Lockstate	0	106	Simple	Unsigned8	1	D	x		→ 163
Com.err.counters	0	107	Record	Endress+Hauser-specific	10	D	x		→ 164
Addressing	0	108	Simple	Unsigned8	1	D	x		→ 164
Alarm behav. P	0	109	Simple	Unsigned8	1	S	x	x	→ 164
Maintenance instructions	0	110	Simple	Array	20	D	x		→ 164
Operator code	0	111	Simple	Unsigned16	2	N	x	x	→ 164
Format ext. val. 1	0	112	Simple	Unsigned8	1	N	x	x	→ 164
Reset	0	113	Simple	Unsigned16	2	D	x	x	→ 164
Code definition	0	114	Simple	Unsigned16	2	N	x	x	→ 165
DIP switch	0	115	Record	Endress+Hauser-specific	4	D	x		→ 165
Last diag. code	0	116	Simple	Array	20	D	x		→ 165
Instructions	0	117	Simple	Unsigned16	2	D	x		→ 165
Download select.	0	118	Simple	Unsigned8	1	D	x	x	→ 165
PB view 1	0	126	Simple	PB_View	17	N	x		→ 165

Analog Input Block 1 and Analog Input Block 2

Parameter	Slot ¹⁾	Index	Object type	Data type	Size (Byte)	Storage Class	Read	Write	Page
Analog Input Block Standard Parameters									
Block object	1 / 2	16	Record	DS-32	20	Cst	x		→ 166
Static rev. no.	1 / 2	17	Simple	Unsigned16	2	N	x		→ 166
TAG	1 / 2	18	Simple	VisibleString	32	S	x	x	→ 166
Strategy	1 / 2	19	Simple	Unsigned16	2	S	x	x	→ 166
Alert key	1 / 2	20	Simple	Unsigned8	1	S	x	x	→ 166
Target mode	1 / 2	21	Simple	Unsigned8	1	S	x	x	→ 167
Block mode	1 / 2	22	Record	DS-37	3	D	x		→ 167
Alarm summary	1 / 2	23	Record	DS-42	8	D	x		→ 167
Analog Input Block Parameters									
Batch information	1 / 2	24	Record	DS-67	10	S	x	x	→ 167
Output value (Out Value)	1 / 2	26	Record	DS-33	5	D	x	x ²⁾	→ 167
Proc value scale	1 / 2	27	Array	Float	8	S	x	x	→ 168
Output scale	1 / 2	28	Record	DS-36	11	S	x	x	→ 168
Characterization	1 / 2	29	Simple	Unsigned8	1	S	x	x	→ 168
Channel	1 / 2	30	Simple	Unsigned16	2	S	x	x	→ 168
Filt. time const.	1 / 2	32	Simple	Float	4	S	x	x	→ 168
Fail safe mode	1 / 2	33	Simple	Unsigned8	1	S	x	x	→ 169
Failsafe default	1 / 2	34	Simple	Float	4	S	x	x	→ 169
Limit hysteresis	1 / 2	35	Simple	Float	4	S	x	x	→ 170
Upper limit alarm	1 / 2	37	Simple	Float	4	S	x	x	→ 170
Upper limit warning	1 / 2	39	Simple	Float	4	S	x	x	→ 170
Lower limit warning	1 / 2	41	Simple	Float	4	S	x	x	→ 171
Lower limit alarm	1 / 2	43	Simple	Float	4	S	x	x	→ 171
Upper limit alarm	1 / 2	46	Record	DS-39	16	D	x		→ 171
Upper limit warning	1 / 2	47	Record	DS-39	16	D	x		→ 171
Lower limit warning	1 / 2	48	Record	DS-39	16	D	x		→ 171
Lower limit alarm	1 / 2	49	Record	DS-39	16	D	x		→ 171
Simulate	1 / 2	50	Record	DS-50	6	S	x	x	→ 172
Unit text	1 / 2	51	Simple	OctetString	16	S	x	x	→ 172
PV scale unit	1 / 2	61	Simple	Unsigned16	2	N	x		→ 172
AI view 1	1 / 2	62	Simple	FB_view	18	D	x		→ 172

- 1) Analog Input Block 1 = Slot 1; Analog Input Block 2 = Slot 2
- 2) If "Block mode" current mode = manual (Man)

Analog Output Block 1 and Analog Output Block 2

Parameter	Slot ¹⁾	Index	Object type	Data type	Size (Byte)	Storage Class	Read	Write	Page
Analog Output Block Standard Parameters									
Block object	3 / 4	16	Record	DS-32	20	Cst	x		→ 173
Static rev. no.	3 / 4	17	Simple	Unsigned16	2	N	x		→ 173
TAG	3 / 4	18	Simple	VisibleString	32	S	x	x	→ 173
Strategy	3 / 4	19	Simple	Unsigned16	2	S	x	x	→ 173
Alert key	3 / 4	20	Simple	Unsigned8	1	S	x	x	→ 174
Target mode	3 / 4	21	Simple	Unsigned8	1	S	x	x	→ 174
Block mode	3 / 4	22	Record	DS-37	3	D	x		→ 174
Alarm summary	3 / 4	23	Record	DS-42	8	D	x		→ 174
Analog Output Block Parameters									
Batch information	3 / 4	24	Record	DS-67	10	S	x	x	→ 174
Input value	3 / 4	26	Record	DS-101	5	D	x		→ 175
Channel	3 / 4	27	Simple	Unsigned16	2	S	x	x	→ 175
Data size	3 / 4	28	Simple	Unsigned8	1	Cst	x		→ 175
Data max. size	3 / 4	29	Simple	Unsigned8	1	Cst	x		→ 175
Fail safe time	3 / 4	32	Simple	Float	4	S	x	x	→ 175
Fail safe mode	3 / 4	33	Simple	Unsigned8	1	S	x	x	→ 175
Failsafe default	3 / 4	34	Simple	Float	4	S	x	x	→ 175
Unit	3 / 4	35	Simple	Unsigned16	2	S	x	x	→ 176
Output value (Out Value)	3 / 4	36	Simple	DS-101	5	D	x	x	→ 176
AO view 1	3 / 4	39	Simple	OctetString	20	D	x		→ 176

1) Analog Output Block 1 = Slot 3; Analog Output Block 2 = Slot 4

Totalizer Block (Deltabar M)

Parameter	Slot	Index	Object type	Data type	Size (Byte)	Storage Class	Read	Write	Page
Totalizer Block Standard Parameters									
Block object	5	16	Record	DS-32	20	Cst	x		→ 177
Static rev. no.	5	17	Simple	Unsigned16	2	N	x		→ 177
TAG	5	18	Simple	VisibleString	32	S	x	x	→ 177
Strategy	5	19	Simple	Unsigned16	2	S	x	x	→ 177
Alert key	5	20	Simple	Unsigned8	1	S	x	x	→ 177
Target mode	5	21	Simple	Unsigned8	1	S	x	x	→ 178
Block mode	5	22	Record	DS-37	3	D	x		→ 178
Alarm summary	5	23	Record	DS-42	8	D	x		→ 178
Totalizer Block Parameters									
Batch information	5	24	Record	DS-67	10	S	x	x	→ 178
Totalizer 1	5	26	Record	DS-36	11	S	x	x	→ 178
Eng. unit totalizer 1	5	27	Simple	Unsigned8	1	S	x	x	→ 178
Channel	5	28	Simple	Unsigned16	2	S	x	x	→ 179
Total 1 value	5	29	Simple	Unsigned8	1	N	x	x	→ 179
Totalizer 1 mode	5	30	Simple	Float	4	S	x	x	→ 179
Total. 1 failsafe	5	31	Simple	Unsigned8	1	S	x	x	→ 179
Preset value	5	32	Simple	Float	4	S	x	x	→ 179
Limit hysteresis	5	33	Simple	Float	4	S	x	x	→ 180
Upper limit alarm	5	34	Simple	Float	4	S	x	x	→ 180
Upper limit warning	5	35	Simple	Float	4	S	x	x	→ 180
Lower limit warning	5	36	Simple	Float	4	S	x	x	→ 180
Lower limit alarm	5	37	Simple	Float	4	S	x	x	→ 181
Upper limit alarm	5	38	Record	DS-39	16	D	x		→ 181
Upper limit warning	5	39	Record	DS-39	16	D	x		→ 181
Lower limit warning	5	40	Record	DS-39	16	D	x		→ 181
Lower limit alarm	5	41	Record	DS-39	16	D	x		→ 181
Tot view 1	5	52	Simple	OctetString	18	D	x		→ 181

Transducer Block

Parameter	Slot	Index	Object type	Data type	Size (Byte)	Storage Class	Read	Write	Page
Transducer Block Standard Parameters									
Block object	6	16	Record	DS-32	20	Cst	x		→ 182
Static rev. no.	6	17	Simple	Unsigned16	2	N	x		→ 182
TAG	6	18	Simple	VisibleString	32	S	x	x	→ 182
Strategy	6	19	Simple	Unsigned16	2	S	x	x	→ 182
Alert key	6	20	Simple	Unsigned8	1	S	x	x	→ 182
Target mode	6	21	Simple	Unsigned8	1	S	x	x	→ 183
Block mode	6	22	Record	DS-37	3	D	x		→ 183
Alarm summary	6	23	Record	DS-42	8	D	x		→ 183
Sensor pressure	6	24	Simple	Float	4	D	x		→ 183
URL sensor	6	25	Simple	Float	4	N	x		→ 183
LRL sensor	6	26	Simple	Float	4	N	x		→ 183
Hi trim sensor	6	27	Simple	Float	4	S	x	x	→ 183
Lo trim sensor	6	28	Simple	Float	4	S	x	x	→ 183
Minimum span	6	29	Simple	Float	4	N	x		→ 183
Press. eng. unit	6	30	Simple	Unsigned16	2	S	x		→ 184
Corrected press.	6	31	Record	DS-33	5	D	x		→ 184
Sensor Meas. Type	6	32	Simple	Unsigned16	2	N	x		→ 184
Sensor serial no.	6	33	Simple	Unsigned32	4	N	x		→ 184
Primary value	6	34	Record	DS-33	5	D	x		→ 184
Primary value unit	6	35	Simple	Unsigned16	2	S	x	x	→ 184
Transmitter type	6	36	Simple	Unsigned16	2	S	x	x	→ 184
Sensor Temp. (Cerabar/Deltapilot)	6	43	Record	DS-33	5	D	x		→ 184
Temp. eng. unit. (Cerabar/Deltapilot)	6	44	Simple	Unsigned16	2	S	x	x	→ 185
Value (sec val 1)	6	45	Record	DS-33	5	D	x		→ 185
Press. eng. unit	6	46	Simple	Unsigned16	2	S	x	x	→ 185
Value (sec val 2)	6	47	Record	DS-33	5	D	x		→ 185
Sec val2 unit	6	48	Simple	Unsigned16	2	S	x	x	→ 185
Characterization	6	49	Simple	Unsigned8	1	S	x	x	→ 185
Measuring range	6	50	Array	Float	8	S	x	x	→ 185
Working range	6	51	Array	Float	8	S	x	x	→ 185
Set low-flow cut-off	6	52	Simple	Float	4	S	x	x	→ 186
Squareroot point	6	53	Simple	Float	4	S	x	x	→ 186
Tab actual numb	6	54	Simple	Unsigned8	1	N	x		→ 186
Line numb.:	6	55	Simple	Unsigned8	1	D	x	x	→ 186
Table max. number	6	56	Simple	Unsigned8	1	N	x		→ 186
Table min. number	6	57	Simple	Unsigned8	1	N	x		→ 186
Simulation mode	6	58	Simple	Unsigned8	1	D	x	x	→ 186
Status (characteristic)	6	59	Simple	Unsigned8	1	D	x		→ 186
Tab xy value	6	60	Array	Float	8	D	x	x	→ 187
Max. meas. press.	6	61	Simple	Float	4	N	x	x ¹⁾	→ 187
Min. meas. press.	6	62	Simple	Float	4	N	x	x ¹⁾	→ 187
Transducer Block Endress+Hauser Parameter									
Empty calib. (Tr)	6	66	Simple	Float	4	S	x	x	→ 187
Full calib.	6	67	Simple	Float	4	S	x	x	→ 187
Pressure Empty/Full	6	68	Array	Float	8	N	x		→ 187
Calibration Empty/Full	6	69	Array	Float	8	N	x		→ 187
Max. Turndown	6	70	Simple	Float	4	S	x	x	→ 187
High-press. side	6	71	Simple	Unsigned8	1	S	x	x	→ 188
Reset peakhold	6	72	Simple	Unsigned8	1	D	x	x	→ 188
Measuring mode	6	73	Simple	Unsigned8	1	S	x	x	→ 188
Simulation mode	6	74	Simple	Unsigned8	1	D	x	x	→ 188
Sim. level	6	76	Simple	Float	4	D	x	x	→ 189
Sim. tank cont.	6	77	Simple	Float	4	D	x	x	→ 189
Sim. flow (Deltabar M)	6	78	Simple	Float	4	D	x	x	→ 189
Sim. pressure	6	79	Simple	Float	4	D	x	x	→ 189
Electr. delta P (Cerabar / Deltapilot)	6	80	Simple	Unsigned8	1	S	x	x	→ 190
Pressure abs range	6	81	Simple	Float	4	N	x		→ 190
Lo trim measured	6	82	Simple	Float	4	N	x	x	→ 190
Hi trim measured	6	83	Simple	Float	4	N	x	x	→ 190
Pos. zero adjust (Deltabar M and gauge pressure sensors)	6	84	Simple	Unsigned8	1	N	x	x	→ 190
Calib. offset (absolute pressure sensor)	6	86	Simple	Float	4	S	x	x	→ 190

Parameter	Slot	Index	Object type	Data type	Size (Byte)	Storage Class	Read	Write	Page
Damping	6	87	Simple	Float	4	S	x	x	→ 190
Meas. pressure	6	88	Simple	Float	4	D	x		→ 191
Unit before lin.	6	89	Simple	Unsigned16	2	S	x	x	→ 192
Calibration mode	6	90	Simple	Unsigned8	1	S	x	x	→ 192
Height unit	6	91	Simple	Unsigned16	2	S	x	x	→ 192
Density unit	6	92	Simple	Unsigned16	2	S	x		→ 192
Adjust density	6	93	Simple	Float	4	S	x	x	→ 192
Process Density	6	94	Simple	Float	4	S	x	x	→ 193
Meas. Level	6	95	Simple	Float	4	D	x		→ 193
Empty height	6	96	Simple	Float	4	S	x	x	→ 193
Full height	6	97	Simple	Float	4	S	x	x	→ 193
Level before lin	6	97	Simple	Float	4	S	x	x	→ 193
Tank description	6	101	Simple	VisibleString	32	S	x	x	→ 193
Lin. mode	6	102	Simple	Unsigned8	1	S	x	x	→ 194
Unit after lin.	6	103	Simple	Unsigned16	2	S	x	x	→ 194
Tank content	6	104	Simple	Float	4	D	x		→ 194
Empty calib.	6	105	Simple	Float	4	S	x	x	→ 194
Full calib.	6	106	Simple	Float	4	S	x	x	→ 195
Tab xy value	6	107	Array	Float	8	D	x		→ 195
Edit table	6	108	Simple	Unsigned8	1	D	x	x	→ 195
Lin tab index 01	6	109	Array	Float	8	D	x	x	→ 195
...									...
Lin tab index 32	6	140	Array	Float	8	D	x	x	→ 195
Ext. value 2	6	141	Record	DS-101	5	D	x		→ 195
Ext.val.2 unit	6	142	Simple	Unsigned16	2	D	x		→ 195
Flow type	6	143	Simple	Unsigned8	1	S	x	x	→ 196
Max. flow	6	144	Simple	Float	4	S	x	x	→ 196
Max. pressure flow	6	145	Simple	Float	4	S	x	x	→ 196
Flow unit	6	146	Simple	Unsigned16	2	S	x	x	→ 196
Mass flow unit	6	147	Simple	Unsigned16	2	S	x	x	→ 196
Std. flow unit	6	148	Simple	Unsigned16	2	S	x	x	→ 196
Norm. flow unit	6	149	Simple	Unsigned16	2	S	x	x	→ 197
Flow unit	6	150	Simple	Unsigned16	2	S	x	x	→ 197
Flow	6	151	Simple	Float	4	D	x		→ 197
Totalizer 2 mode	6	153	Simple	Unsigned8	1	S	x	x	→ 197
Totalizer 2	6	154	Simple	Float	4	D	x	x	→ 197
Eng. unit totalizer 2	6	155	Simple	Unsigned16	2	S	x	x	→ 197
Totalizer 2	6	156	Simple	VisibleString	8	D	x		→ 197
Totalizer 2 overflow	6	157	Simple	VisibleString	8	D	x		→ 198
Eng. unit totalizer 2	6	158	Simple	Unsigned16	2	S	x	x	→ 197
Eng. unit totalizer 2	6	159	Simple	Unsigned16	2	S	x	x	→ 197
Eng. unit totalizer 2	6	160	Simple	Unsigned16	2	S	x	x	→ 197
Eng. unit totalizer 2	6	161	Simple	Unsigned16	2	S	x	x	→ 197
Totalizer 1	6	162	Simple	VisibleString	8	D	x		→ 198
Totalizer 1 overflow	6	163	Simple	VisibleString	8	D	x		→ 198
Total. 2 failsafe	6	164	Simple	Unsigned8	1	S	x	x	→ 198
Damping	6	165	Simple	Float	4	S	x		→ 198
Level selection	6	166	Simple	Float	1	S	x	x	→ 198
High-press. side	6	167	Simple	Unsigned8	1	N	x		→ 199
Fixed ext. value (Cerabar / Deltapilot)	6	168	Simple	Float	4	S	x	x	→ 199
Empty pressure	6	169	Simple	Float	4	S	x	x	→ 199
Full pressure	6	170	Simple	Float	4	S	x	x	→ 199
Pressure af. damp	6	171	Simple	Float	4	D	x		→ 199
Calib. Offset	6	172	Simple	Float	4	S	x	x	→ 200
Sensor temp.	6	173	Simple	Float	4	D	x		→ 200
X-value	6	174	Simple	Float	4	D	x		→ 200
Sensor serial no.	6	175	Simple	VisibleString	16	N	x		→ 200
Totalizer 1	6	176	Simple	Float	4	D	x		→ 200
PaTbRangeParameters	6	177	Record	X	32	S	x	x	→ 201
Eng. unit totalizer 1	6	178	Simple	Unsigned16	2	S	x	x	→ 201
Eng. unit totalizer 1	6	179	Simple	Unsigned16	2	S	x	x	→ 201
Eng. unit totalizer 1	6	180	Simple	Unsigned16	2	S	x	x	→ 201
Eng. unit totalizer 1	6	181	Simple	Unsigned16	2	S	x	x	→ 201
TB View 1	6	250	Simple	OctetString	18	D	x		→ 201

1) Can only be reset

6.4.10 Data format

In PROFIBUS PA, the analog values are cyclically transmitted to the PLC in data blocks that are 5 bytes long. The measured value is represented in the first 4 bytes in the form of floating point numbers in accordance with the IEEE standard. The 5th byte contains standardized status information pertaining to the device.

Byte 1	Byte 2	Byte 3	Byte 4	Byte 5
Measured value as IEEE 754 floating point number				Status

The measured value is transmitted as an IEEE 754 floating point number as follows:

$$\text{Measured value} = (-1)^{\text{Sign}} \times 2^{(E - 127)} \times (1 + F)$$

D15	D14	D13	D12	D11	D10	D9	D8	D7	D6	D5	D4	D3	D2	D1	D0
Sign	Exponent (E)								Fraction (F)						
	2 ⁷	2 ⁶	2 ⁵	2 ⁴	2 ³	2 ²	2 ¹	2 ⁰	2 ⁻¹	2 ⁻²	2 ⁻³	2 ⁻⁴	2 ⁻⁵	2 ⁻⁶	2 ⁻⁷
Fraction (F)															
2 ⁻⁸	2 ⁻⁹	2 ⁻¹⁰	2 ⁻¹¹	2 ⁻¹²	2 ⁻¹³	2 ⁻¹⁴	2 ⁻¹⁵	2 ⁻¹⁶	2 ⁻¹⁷	2 ⁻¹⁸	2 ⁻¹⁹	2 ⁻²⁰	2 ⁻²¹	2 ⁻²²	2 ⁻²³

Example

40 F0 00 00 hex = 0100 0000 1111 000 000 000 0000 binary

$$\begin{aligned} \text{Value} &= (-1)^0 \times 2^{(129 - 127)} \times (1 + 2^{-1} + 2^{-2} + 2^{-3}) \\ &= 1 \times 2^2 \times (1 + 0.5 + 0.25 + 0.125) \\ &= 1 \times 4 \times 1.875 \\ &= 7.5 \end{aligned}$$

Restrictions:

- Not all programmable logic controllers support the IEEE 754 format. In such cases, a conversion module must be used or written.
- Depending on the data management mode (most-significant byte or low significant byte) used in the PLC (master), the byte sequence may have to be changed (byte swapping routine).

Data structures

A number of data types, e.g. DS-36, are listed in the slot/index table. These data types are data structures, structured in accordance with the PROFIBUS PA Specification, Part 1, Version 3.0. They consist of several elements that are addressed via the slot, index and sub-index:

Parameter name	Type	Slot	Index	Element	Sub-index	Type	Size (Byte)
Output value (Out Value)	DS-33	1	26	Output value (Out Value)	1	Float	4
				Status (Device Status)	5	Unsigned8	1

Parameter name	Type	Slot	Index	Element	Sub-index	Type	Size (Byte)
Output scale	DS-36	1	28	Upper value	1	Float	4
				Lower value	5	Float	4
				Unit	9	Unsigned16	2
				Decimal point	11	Integer8	1

6.4.11 Assignment of the PA profile to internal parameters

As defined in the specification of the Profibus device, the following table describes the influence of the profile parameters on the basic parameters and the assignment of the Transducer Block:

Sensor Type	Basic parameter				PROFIBUS PA profile parameter		
	Measuring mode (005)	Flow type (044)	Lin. mode (037) ¹⁾	Primary value unit	Characterization type (TB_LIN_TYPE)	Transmitter type (PV_TYPE)	Unit (PV_UNIT)
Absolute pressure/ gauge pressure/ diff.	Pressure			Press. eng. unit (125)	No linearization (=0)	Pressure (=0)	Press. eng. unit
Differential (Deltabar)	Flow	Volume operat. cond.		Flow unit (048)	Square root (=10)	Flow (=1)	Volume flow unit
	Flow	Vol. norm. cond.		Norm. flow unit (046)	Square root (=10)	Flow (=1)	Norm. flow unit
	Flow	Vol. std. cond.		Std. flow unit (047)	Square root (=10)	Flow (=1)	Standard flow unit
	Flow	Mass		Mass flow unit (045)	Square root (=10)	Flow (=1)	Mass flow unit
	Flow	Flow in %		% (172)	Square root (=10)	Flow (=1)	%
Absolute pressure/ gauge pressure/ diff.	Level (linear)		Linear or Table editing mode	Unit before lin (025)	No linearization (=0)	Level easy (=130)	Level unit (% Volume, Mass, Height)
	Level (with lin. table)		Activate table	Unit after lin. (038)	Linearization (=1)	Level easy (=130)	Level unit (% Volume, Mass, Height)

- 1) The device uses the "Lin. mode (037)" parameter internally to enable or disable the linearization table (to set the device to the linear or linearization measuring mode). The same parameter is also used to set the table to the edit mode or to check and validate the edited table.

The editing, enabling/disabling and control of the linearization table in the "Level" measuring mode affects the Transducer Block and the internal "Basic" parameters. They have to be assigned to one another to obtain a simple mechanism between the internal and profile configuration.

The device only contains one table and the linearization cannot be activated while the table is being edited or if the table is incorrect. We have defined that the "Level" mode must be linear in such instances. The "Characterization Type" parameter (TB_TYPE) must be set to "Linear" as soon as the linearization table is disabled or is being edited or cannot be enabled.

If the level configuration is modified:

1. Using the "Basic" parameters:

- Successful modification of the LinearisationTableMode basic parameter ("Lin. mode (037)") to "Linear" or "Activate table" must update the PA profile parameters. If the linearization table could not be activated due to a mistake in the table, the "Characterization Type" (TB_TYPE) parameter then remains unchanged.
- The linearization table mode ("Lin. mode (037)" basic parameter) can be set to the editing mode (manual or semi-automatic entry): in instances of this nature, the "Characterization Type" (TB_TYPE) Profibus parameter must be changed to "Linear".
- The "Erase table" option of the "Lin. mode (037)" basic parameter resets the parameter to "Linear" so that the "Characterization Type" (TB_TYPE) parameter must return to "No linearization".

2. Using the PA profile parameters:

- The modification of the Characterization Type (TB_LIN_TYPE) PA profile parameter updates the basic parameter "Lin. mode (037)". If the linearization table cannot be activated due to a mistake in the table, then the table must be corrected and activated again.

To edit the table the parameter Simulation mode (TAB_OP_CODE) must be set to 1 (Editing) to allow the edition. At the end of the edition the new table can be activated by setting 3 (Check and activate table).

Measuring mode (TAB_OP_CODE)	Function	Effect on "Lin. mode (037)"
0	Reset table	Delete table, then "Linear"
1	Editing	Manual entry
3	Check and activate table	Activate table if the table is correct or leave the table unchanged.
4	Delete point (only available in the manual and semiautomatic mode)	Manual or semi automatic entry
5	Enter point (only available in the manual and semiautomatic mode)	Manual or semi automatic entry

The Characterization parameter (TB_LIN_TYPE) is affected by:

- Simulation mode (TAB_OP_CODE): If the table is being edited, the Characterization parameter (TB_LIN_TYPE) is automatically set to "Linear". If the table was activated successfully, the Characterization Type parameter (TB_LIN_TYPE) is automatically set to "Linearization".
- "Lin. mode (037)": Just as in the case of the Simulation mode (TAB_OP_CODE), this parameter is also used by the basic application to set the device to linear or linearized conversion or to edit the linearization table. The "Linear", "Manual entry", "Semi-auto. entry" or "Delete table" options must reset Characterization parameter (TB_LIN_TYPE) to "Linear". The "Activate table" option with a successful result must reset the Characterization parameter (TB_LIN_TYPE) to "Linearization".

7 Commissioning without an operating menu

The device is configured at the factory for the Pressure measuring mode (Cerabar, Deltabar) or Level measuring mode (Deltapilot). The measuring range and the unit in which the measured value is transmitted correspond to the specifications on the nameplate.

⚠ WARNING

Exceeding the maximum allowable working pressure!

Risk of injury due to bursting of parts! Warning messages are generated if pressure is too high.

- ▶ If a pressure smaller than the minimum permitted pressure or greater than the maximum permitted pressure is present at the device, the following messages are output in succession (depending on the setting in the "Alarm behavior" (050) parameter):
 - "S140 Working range P" or "F140 Working range P"
 - "S841 Sensor range" or "F841 Sensor range"
 - "S971 Adjustment"
- Use the device only within the sensor range limits.

NOTICE



Shortfall of the allowable working pressure!

Output of messages if pressure is too low.

- ▶ If a pressure smaller than the minimum permitted pressure or greater than the maximum permitted pressure is present at the device, the following messages are output in succession (depending on the setting in the "Alarm behavior" (050) parameter):
 - "S140 Working range P" or "F140 Working range P"
 - "S841 Sensor range" or "F841 Sensor range"
 - "S971 Adjustment"
- Use the device only within the sensor range limits.

7.1 Function check

Carry out a post-installation and a post-connection check as per the checklist before commissioning the device.

- "Post-installation check" checklist →  38
- "Post-connection check" checklist →  44

7.2 Position adjustment

The following functions are possible by means of the key on the electronic insert:

- Position adjustment (zero point correction)
- Device reset →  47 (total reset)



- Operation must be unlocked. →  54, "Locking/unlocking operation"
- The device is configured for the "Pressure" measuring mode as standard.
- The pressure applied must be within the nominal pressure limits of the sensor. See information on the nameplate.

Carrying out position adjustment
Pressure is present at device.
↓
Press the "Zero" key for at least 3 s.
↓

Carrying out position adjustment	
Does the LED on the electronic insert light up briefly?	
Yes	No
↓	↓
Applied pressure for position adjustment has been accepted.	¹⁾ Applied pressure for position adjustment has not been accepted. Observe the input limits.

1) Observe warning on commissioning (→  82)

8 Commissioning with an operating menu (onsite display/FieldCare)

The device is configured at the factory for the Pressure measuring mode (Cerabar, Deltabar) or Level measuring mode (Deltapilot). The measuring range and the unit in which the measured value is transmitted correspond to the specifications on the nameplate.

▲ WARNING

Exceeding the maximum allowable working pressure!

Risk of injury due to bursting of parts! Warning messages are generated if pressure is too high.

- ▶ If a pressure smaller than the minimum permitted pressure or greater than the maximum permitted pressure is present at the device, the following messages are output in succession (depending on the setting in the "Alarm behavior" (050) parameter):
"S140 Working range P" or "F140 Working range P"
"S841 Sensor range" or "F841 Sensor range"
"S971 Adjustment"
Use the device only within the sensor range limits.

NOTICE



Shortfall of the allowable working pressure!

Output of messages if pressure is too low.

- ▶ If a pressure smaller than the minimum permitted pressure or greater than the maximum permitted pressure is present at the device, the following messages are output in succession (depending on the setting in the "Alarm behavior" (050) parameter):
"S140 Working range P" or "F140 Working range P"
"S841 Sensor range" or "F841 Sensor range"
"S971 Adjustment"
Use the device only within the sensor range limits.

8.1 Function check

Carry out a post-installation and a post-connection check as per the checklist before commissioning the device.

- "Post-installation check" checklist →  38
- "Post-connection check" checklist →  44

8.2 Commissioning

Commissioning comprises the following steps:

1. Function check → [84](#)
2. Selecting the language, measuring mode and pressure unit → [85](#)
3. Position adjustment → [86](#)
4. Configuring measurement:
 - Pressure measurement → [101 ff](#)
 - Level measurement (Cerabar M and Deltapilot M) → [87 ff](#)
 - Flow measurement (Deltabar M) → [104 ff](#)
 - Level measurement (Deltabar M) → [107 ff](#)

8.2.1 Selecting the language, measuring mode and pressure unit

Language selection

Parameter name	Description
Language (000) Options Menu path: Main menu → Language	Select the language for the onsite display. Options: <ul style="list-style-type: none"> ▪ English ▪ Possibly another language (as selected when ordering the device) ▪ One further language (language of the manufacturing plant) Factory setting: English

Measuring mode selection

Parameter name	Description
Measuring mode (005) Options Menu path: Setup → Measuring mode (005)	Select the measuring mode. The operating menu is structured differently depending on the measuring mode selected. ⚠ WARNING Changing the measuring mode affects the span (URV)! This situation can result in product overflow. <ul style="list-style-type: none"> ▶ If the measuring mode is changed, the span setting (URV) must be verified and, if necessary, reconfigured! Options: <ul style="list-style-type: none"> ▪ Pressure ▪ Level ▪ Flow Factory setting: Pressure

Pressure unit selection

Parameter name	Description
Press. eng. unit (125) Options Menu path: Setup → Press. eng. unit (125)	Select the pressure unit. If a new pressure unit is selected, all pressure-specific parameters are converted and displayed with the new unit. Options: <ul style="list-style-type: none"> ▪ mbar, bar ▪ mmH₂O, mH₂O, ▪ inH₂O, ftH₂O ▪ Pa, kPa, MPa ▪ psi ▪ mmHg, inHg ▪ kgf/cm² Factory setting: mbar or bar depending on the sensor nominal measuring range, or as per order specifications

8.3 Position zero adjustment

The pressure resulting from the orientation of the device can be corrected here.

Parameter name	Description
Corrected press. (172) Display Menu path: Setup → Corrected press. (172)	Displays the measured pressure after sensor trim and position adjustment.  If this value is not equal to "0", it can be corrected to "0" by the position adjustment.
Pos. zero adjust (007) (Deltabar M and gauge pressure sensor) Options Menu path: Setup → Pos. zero adjust (007) (Deltabar and gauge pressure sensor)	Position adjustment – the pressure difference between zero (set point) and the measured pressure need not be known. Example: <ul style="list-style-type: none"> – Measured value = 2.2 mbar (0.032 psi) – Correct the measured value via the "Pos. zero adjust (007) (Deltabar and gauge pressure sensor)" parameter with the "Confirm" option. This means that you are assigning the value 0.0 to the pressure present. – Measured value (after pos. zero adjust) = 0.0 mbar Options <ul style="list-style-type: none"> ▪ Confirm ▪ Abort Factory setting: Abort
Calib. offset (192) (008) (absolute pressure sensor) Entry Menu path: Setup → Calib. offset (192)	Position adjustment – the pressure difference between the set point and the measured pressure must be known. Example: <ul style="list-style-type: none"> – Measured value = 982.2 mbar (14.25 psi) – You correct the measured value with the value entered (e.g. 2.2 mbar (0.032 psi)) via the "Calib. offset (192)" parameter. This means that you are assigning the value 980.0 (14.21 psi) to the pressure present. – Measured value (after calib. offset) = 980.0 mbar (14.21 psi) Factory setting: 0.0

8.4 Level measurement (Cerabar M and Deltapilot M)

8.4.1 Information on level measurement

- The limit values are not checked, i.e. the values entered must be appropriate for the sensor and the measuring task for the device to be able to measure correctly.
- Customer-specific units are not possible.
- There is no unit conversion.
- The values entered for "**Empty calib. (028)/Full calib. (031)**", "**Empty pressure (029)/ Full pressure (032)**", "**Empty height (030)/Full height (033)**" must be at least 1 % apart. The value will be rejected, and a warning message displayed, if the values are too close together.

You have a choice of two methods for calculating the level: "In pressure" and "In height". The table in the "Overview of level measurement" section that follows provides you with an overview of these two measuring tasks.

8.4.2 Overview of level measurement

Measuring task	Level selection	Measured variable options	Description	Measured value display
Calibration is performed by entering two pressure-level value pairs.	"In pressure"	Via the " Unit before lin (025) " parameter: %, level, volume or mass units.	<ul style="list-style-type: none"> - Calibration with reference pressure (wet calibration), see → 88 - Calibration without reference pressure (dry calibration), see → 90 	The measured value display and the " Level before lin. (019) " parameter display the measured value.
Calibration is performed by entering the density and two height-level value pairs.	"In height"		<ul style="list-style-type: none"> - Calibration with reference pressure (wet calibration), see → 92 - Calibration without reference pressure (dry calibration), see → 94 	

8.4.3 "In pressure" level selection Calibration with reference pressure (wet calibration)

Example:

In this example, the level in a tank should be measured in "m". The maximum level is 3 m (9.8 ft). The pressure range is due to the filling height and the density.

Prerequisite:

- The measured variable is in direct proportion to the pressure.
- The tank can be filled and emptied.



The values entered for **"Empty calib. (028)/Full calib. (031)"** and the pressures present at the device must be at least 1% apart. The value will be rejected, and a warning message displayed, if the values are too close together. Further limit values are not checked; i.e. the values entered must be appropriate for the sensor and the measuring task so that the measuring device can measure correctly.

Description	
1	Perform "position adjustment" → 86.
2	Select the "Level" measuring mode via the "Measuring mode (005)" parameter. Menu path: Setup → Measuring mode (005)
3	Select a pressure unit via the "Press. eng. unit (125)" parameter, here "mbar" for example. Menu path: Setup → Press. eng. unit (125)
4	Select the "in pressure" level mode by means of the "Level selection (024)" parameter. Menu path: Setup → Extended Setup → Level → Level selection (024)

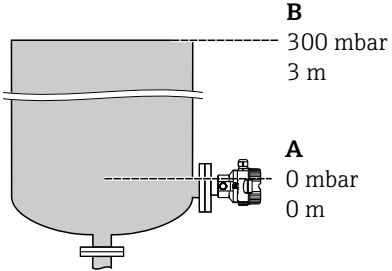

B
300 mbar
3 m

A
0 mbar
0 m

A0030028

Fig. 29: Calibration with reference pressure – wet calibration

A See Table, Step 7.
B See Table, Step 8.

Description	
5	<p>Select a level unit by means of the "Unit before lin (025)" parameter, here "m" for example.</p> <p>Menu path: Setup → Extended Setup → Level → Unit before lin (025)</p>
6	<p>Select the "Wet" option by means of the "Calibration mode (027)" parameter.</p> <p>Menu path: Setup → Extended Setup → Level → Calibration mode (027)</p>
7	<p>The pressure for the lower calibration point is present at the device, here 0 mbar for example.</p> <p>Select the "Empty calib. (028)" parameter.</p> <p>Menu path: Setup → Extended Setup → Level → Empty calib. (028)</p> <p>Enter the level value, here 0 m for example. The pressure value present is assigned to the lower level value by confirming the value.</p>
8	<p>The pressure for the upper calibration point is present at the device, here 300 mbar (4.35 psi) for example.</p> <p>Select the "Full calib. (031)" parameter.</p> <p>Menu path: Setup → Extended Setup → Level → Full calib. (031)</p> <p>Enter the level value, here 3 m (9.8 ft) for example. The pressure value present is assigned to the upper level value by confirming the value.</p>
9	<p>If calibration is performed with a medium other than the process medium, enter the density of the calibration medium in "Adjust density (034)".</p> <p>Menu path: Setup → Extended Setup → Level → Adjust density (034)</p>
10	<p>If calibration was performed with a medium other than the process medium, specify the density of the process medium in the "Process density (035)" parameter.</p> <p>Menu path: Setup → Extended setup → Level → Process density (035).</p>
11	<p>Result: The measuring range is set for 0 to 3 m (9.8 ft).</p>

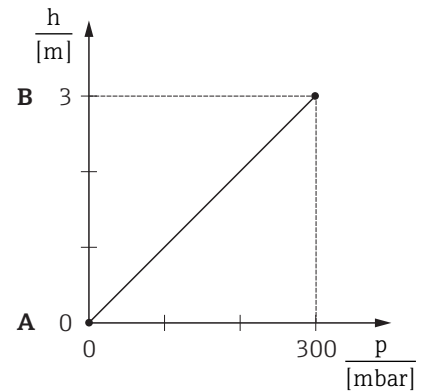

Fig. 30: Calibration with reference pressure - wet calibration

A0017658

A See Table, Step 7.
B See Table, Step 8.



The measured variables %, level, volume and mass are available for this level mode. See → 134 "**Unit before lin (025)**".

8.4.4 "In pressure" level selection Calibration without reference pressure (dry calibration)

Example:

In this example, the volume in a tank should be measured in liters. The maximum volume of 1000 liters (264 gal) corresponds to a pressure of 450 mbar (6.53 psi). The minimum volume of 0 liters corresponds to a pressure of 50 mbar (0.72 psi) since the device is mounted below the start of the level measuring range.

Prerequisite:

- The measured variable is in direct proportion to the pressure.
- This is a theoretical calibration i.e. the pressure and volume values for the lower and upper calibration point must be known.



- The values entered for "**Empty calib. (028)/Full calib. (031)**", "**Empty pressure (029)/Full pressure (032)**" must be at least 1% apart. The value will be rejected, and a warning message displayed, if the values are too close together. Further limit values are not checked; i.e. the values entered must be appropriate for the sensor and the measuring task so that the measuring device can measure correctly.
- Due to the orientation of the device, there may be pressure shifts in the measured value, i.e. when the container is empty or partly filled, the measured value is not zero. For information on how to perform position adjustment, see → 86, "Position zero adjustment".

Description	
1	Select the "Level" measuring mode via the " Measuring mode (005) " parameter. Menu path: Setup → Measuring mode (005)
2	Select a pressure unit via the " Press. eng. unit (125) " parameter, here "mbar" for example. Menu path: Setup → Press. eng. unit (125)
3	Select the "in pressure" level mode by means of the " Level selection (024) " parameter. Menu path: Setup → Extended Setup → Level → Level selection (024)
4	Select a volume unit via the " Unit before lin (025) " parameter, here "l" (liter) for example. Menu path: Setup → Extended Setup → Level → Unit before lin (025)

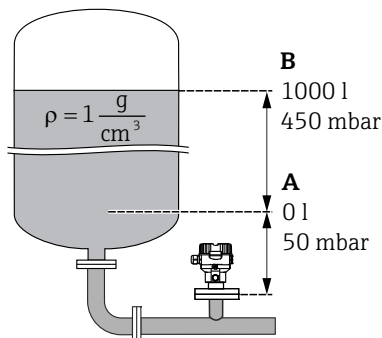

B
1000 l
450 mbar

A
0 l
50 mbar

A0030030

Fig. 31: Calibration without reference pressure – dry calibration

A See Table, Steps 7 + 8.
B See Table, Steps 9 + 10.

Description	
5	Select the "Dry" option by means of the " Calibration mode (027) " parameter. Menu path: Setup → Extended Setup → Level → Calibration mode (027)
6	" Adjust density (034) " contains the factory setting 1.0, but this value can be changed if required. The entered value pairs must correspond to this density. Menu path: Setup → Extended Setup → Level → Adjust density (034)
7	Enter the volume value for the lower calibration point via the " Empty calib. (028) " parameter, here 0 liters for example. Menu path: Setup → Extended Setup → Level → Empty calib. (028)
8	Enter the pressure value for the lower calibration point via the " Empty pressure (029) " parameter, here 50 mbar (0.72 psi) for example. Menu path: Setup → Extended Setup → Level → Empty pressure (029)
9	Enter the volume value for the upper calibration point via the " Full calib. (031) " parameter, here 1000 liters (264 gal) for example. Menu path: Setup → Extended Setup → Level → Full calib. (031)
10	Enter the pressure value for the upper calibration point via the " Full pressure (032) " parameter, here 450 mbar (6.53 psi) for example. Menu path: Setup → Extended Setup → Level → Full pressure (032)
11	If calibration was performed with a medium other than the process medium, specify the density of the process medium in the " Process density (035) " parameter. Menu path: Setup → Extended setup → Level → Process density (035) .
12	Result: The measuring range is set for 0 to 1000 l (264 gal).

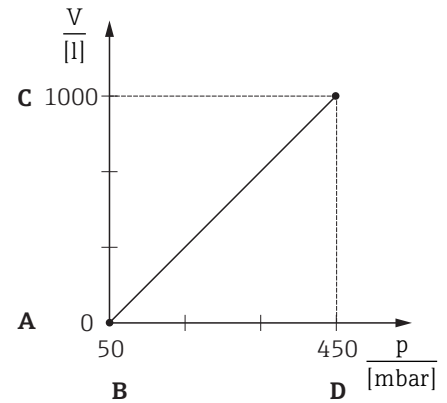

Fig. 32: Calibration with reference pressure – wet calibration

- A See Table, Step 7.
- B See Table, Step 8.
- C See Table, Step 9.
- D See Table, Step 10.

A0031028



The measured variables %, level, volume and mass are available for this level mode.
See → 134 "**Unit before lin (025)**".

8.4.5 "In height" level selection Calibration with reference pressure (wet calibration)

Example:

In this example, the volume in a tank should be measured in liters. The maximum volume of 1000 liters (264 gal) corresponds to a level of 4.5 m (14.8 ft). The minimum volume of 0 liters corresponds to a level of 0.5 m (1.6 ft) since the device is mounted below the start of the level measuring range.

The density of the medium is 1 g/cm³ (1 SGU).

Prerequisite:

- The measured variable is in direct proportion to the pressure.
- The tank can be filled and emptied.



The values entered for "Empty calib. (028)/Full calib. (031)" and the pressure values present at the device must be at least 1% apart. The value will be rejected, and a warning message displayed, if the values are too close together. Further limit values are not checked; i.e. the values entered must be appropriate for the sensor and the measuring task so that the measuring device can measure correctly.

Description	
1	Perform position adjustment. See → 86.
2	Select the "Level" measuring mode via the "Measuring mode (005)" parameter. Menu path: Setup → Measuring mode (005)
3	Select a pressure unit via the "Press. eng. unit (125)" parameter, here "mbar" for example. Menu path: Setup → Press. eng. unit (125)
4	Select the "in height" level mode via the "Level selection (024)" parameter. Menu path: Setup → Extended Setup → Level → Level selection (024)
5	Select a volume unit via the "Unit before lin (025)" parameter, here "l" (liter) for example. Menu path: Setup → Extended Setup → Level → Unit before lin (025)

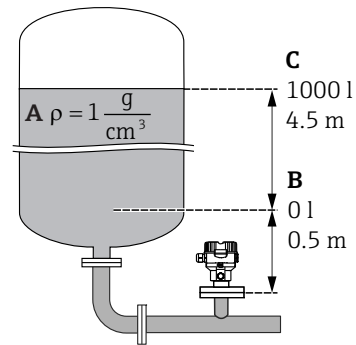

Fig. 33: Calibration with reference pressure – wet calibration

- A See Table, Step 8.
- B See Table, Step 9.
- B See Table, Step 9.

A0031027

Description	
6	Select a level unit by means of the " Height unit (026) " parameter, here "m" for example. Menu path: Setup → Extended Setup → Level → Height unit (026)
7	Select the "Wet" option by means of the " Calibration mode (027) " parameter. Menu path: Setup → Extended Setup → Level → Calibration mode (027)
8	If calibration is performed with a medium other than the process medium, enter the density of the calibration medium in the " Adjust density (034) " parameter, here 1 g/cm ³ (1 SGU) for example. Menu path: Setup → Extended Setup → Level → Adjust density (034)
9	The pressure for the lower calibration point is present at the device, here 0.5 m covered / 49 mbar (0.71 psi) for example. Enter the volume value for the lower calibration point via the " Empty calib. (028) " parameter, here 0 liters for example. Menu path: Setup → Extended Setup → Level → Empty calib. (028)
10	The pressure for the upper calibration point is present at the device, here 4.5 m covered / 441 mbar (6.4 psi) for example. Enter the volume value for the upper calibration point via the " Full calib. (031) " parameter, here "1000 liters" (264 gal) for example. Menu path: Setup → Extended Setup → Level → Full calib. (031)
11	If calibration was performed with a medium other than the process medium, specify the density of the process medium in the " Process density (035) " parameter. Menu path: Setup → Extended Setup → Level → Process density (035)
12	Result: The measuring range is set for 0 to 1000 l (264 gal).

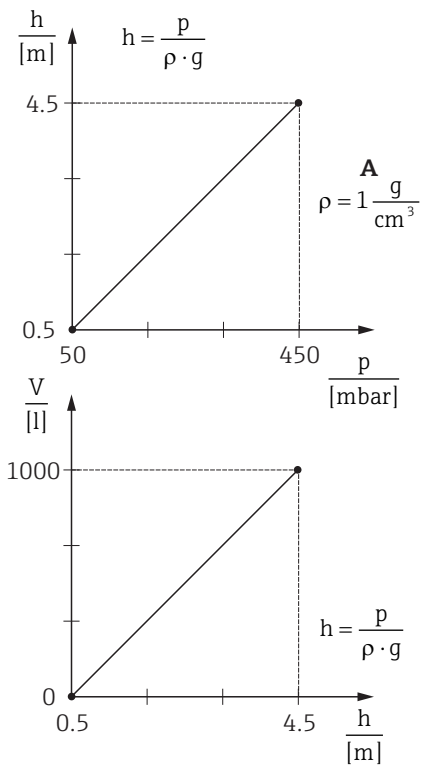

Fig. 34: Calibration with reference pressure - wet calibration
 A See Table, Step 8.
 B See Table, Step 9.
 C See Table, Step 10.



The measured variables %, level, volume and mass are available for this level mode → 134 "**Unit before lin (025)**".

8.4.6 "In height" level selection Calibration without reference pressure (dry calibration)

Example:

In this example, the volume in a tank should be measured in liters. The maximum volume of 1000 liters (264 gal) corresponds to a level of 4.5 m (14.8 ft). The minimum volume of 0 liters corresponds to a level of 0.5 m (1.6 ft) since the device is mounted below the start of the level measuring range.

Prerequisite:

- The measured variable is in direct proportion to the pressure.
- This is a theoretical calibration i.e. the height and volume values for the lower and upper calibration point must be known.



- The values entered for "Empty calib. (028)/Full calib. (031)", "Empty height (030)/Full height (033)" must be at least 1% apart. The value will be rejected, and a warning message displayed, if the values are too close together. Further limit values are not checked; i.e. the values entered must be appropriate for the sensor and the measuring task so that the measuring device can measure correctly.
- Due to the orientation of the device, there may be pressure shifts in the measured value, i.e. when the container is empty or partly filled, the measured value is not zero. For information on how to perform position adjustment, see → 86, "Position zero adjustment".

Description	
1	Select the "Level" measuring mode via the "Measuring mode (005)" parameter. Menu path: Setup → Measuring mode (005)
2	Select a pressure unit via the "Press. eng. unit (125)" parameter, here "mbar" for example. Menu path: Setup → Press. eng. unit (125)
3	Select the "in height" level mode via the "Level selection (024)" parameter. Menu path: Setup → Extended Setup → Level → Level selection (024)
4	Select a volume unit via the "Unit before lin (025)" parameter, here "l" (liter) for example. Menu path: Setup → Extended Setup → Level → Unit before lin (025)
5	Select a level unit by means of the "Height unit (026)" parameter, here "m" for example. Menu path: Setup → Extended Setup → Level → Height unit (026)
6	Select the "Dry" option by means of the "Calibration mode (027)" parameter. Menu path: Setup → Extended Setup → Level → Calibration mode (027)
7	Enter the density of the medium via the "Adjust density (034)" parameter, here "1 g/cm ³ " (1 SGU) for example. Menu path: Setup → Extended Setup → Level → Adjust density (034)

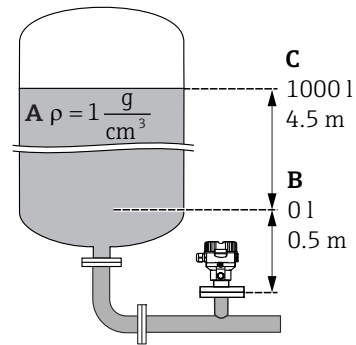

Fig. 35: Calibration without reference pressure – dry calibration

- A See Table, Step 7.
- B See Table, Step 8 and 10.
- C See Table, Step 9 and 11.

Description	
8	<p>Enter the volume value for the lower calibration point via the "Empty calib. (028)" parameter, here 0 liters for example.</p> <p>Menu path: Setup → Extended Setup → Level → Empty calib. (028)</p>
9	<p>Enter the height value for the lower calibration point via the "Empty height (030)" parameter, here 0.5 m (1.6 ft) for example.</p> <p>Menu path: Setup → Extended Setup → Level → Empty height (030)</p>
10	<p>Enter the volume value for the upper calibration point via the "Full calib. (031)" parameter, here 1000 liters (264 gal) for example.</p> <p>Menu path: Setup → Extended Setup → Level → Full calib. (031)</p>
11	<p>Enter the height value for the upper calibration point via the "Full height (033)" parameter, here 4.5 m (14.8 ft) for example.</p> <p>Menu path: Setup → Extended Setup → Level → Full height (033)</p>
12	<p>If the process uses a medium other than that on which the calibration was based, the new density must be specified in the "Process density (035)" parameter.</p> <p>Menu path: Setup → Extended setup → Level → Process density (035).</p>
13	<p>Result: The measuring range is set for 0 to 1000 l (264 gal).</p>

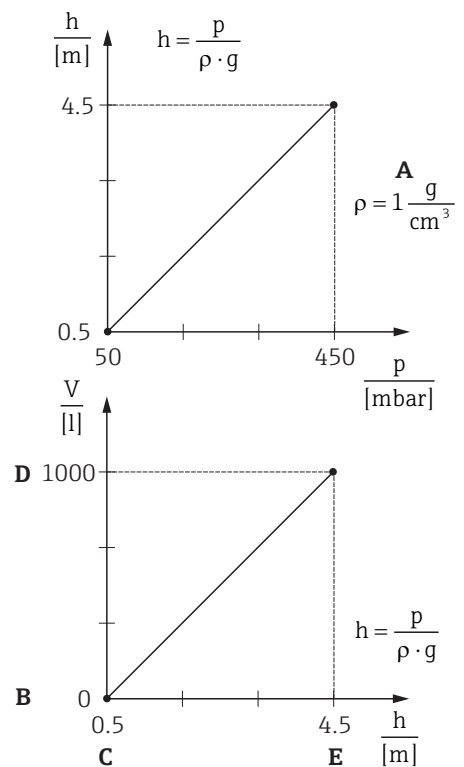















Fig. 36: Calibration with reference pressure - wet calibration

- A See Table, Step 7.
- B See Table, Step 8.
- C See Table, Step 9.
- D See Table, Step 10.
- E See Table, Step 11.



The measured variables %, level, volume and mass are available for this level mode → 134 "Unit before lin (025)".

8.4.7 Required parameters for Level measuring mode

Parameter name	Description
Level selection (024)	→  134
Unit before lin (025)	→  134
Height unit (026)	→  134
Calibration mode (027)	→  134
Empty calib. (028)	→  135
Empty pressure (029)	→  135
Empty height (030)	→  135
Full calib. (031)	→  135
Full pressure (032)	→  135
Full height (033)	→  135
Density unit (127)	→  136
Adjust density (034)	→  136
Process density (035)	→  136
Level before lin. (019)	→  136

8.5 Linearization

8.5.1 Manual entry of the linearization table via onsite display

Example:

In this example, the volume in a tank with a conical outlet should be measured in m³.

Prerequisite:

- This is a theoretical calibration, i.e. the points for the linearization table are known.
- A level calibration has been performed.



For a description of the parameters mentioned, → Chap. 8.11 "Description of parameters".

Description	
<p>1 Select the "Manual entry" option via the "Lin. mode (037)" parameter.</p> <p>Menu path: Setup → Extended Setup → Linearization → Lin. mode (037)</p>	
<p>2 Select a unit via the "Unit after lin. (038)" parameter, e.g. m³.</p> <p>Menu path: Setup → Extended Setup → Linearization → Unit after lin. (038)</p>	
<p>3 Enter the number of the point in the table via the "Line numb. (039)" parameter.</p> <p>Menu path: Setup → Extended Setup → Linearization → Line numb. (039)</p>	
<p>The level is entered via the "X-value (040) (manual entry)" parameter, here 0 m for example. Confirm your entry.</p> <p>Menu path: Setup → Extended Setup → Linearization → X-value (040) (manual entry)</p>	
<p>Using the "Y-value (041) (manual entry/in semi-auto. entry)" parameter, enter the associated volume value, here 0 m³ for example, and confirm the value.</p> <p>Menu path: Setup → Extended Setup → Linearization → Y-value (041) (manual entry/in semi-auto. entry)</p>	

	Description
4	To enter another point in the table, select the "Next point" option via the " Edit table (042) " parameter. Enter the next point as explained in Step 3. Menu path: Setup → Extended Setup → Linearization → Edit table (042)
5	Once all the points have been entered in the table, select the "Activate table" option via the " Lin. mode (037) " parameter. Menu path: Setup → Extended Setup → Linearization → Lin. mode (037)
6	Result: The measured value after linearization is displayed.



Error message F510 "Linearization" is displayed as long as the table is being entered and is not activated.

8.5.2 Manual entry of the linearization table via the operating tool

Using an operating tool based on FDT technology (e.g. FieldCare), you can enter linearization using a module specially designed for this purpose. This provides you with an overview of the selected linearization even during entry. In addition, it is possible to access preprogrammed tank shapes.



The linearization table may also be entered manually point by point in the operating tool menu, see → Chap. 8.5.1 "Manual entry of the linearization table via onsite display".

8.5.3 Semi-automatic entry of the linearization table

Example:

In this example, the volume in a tank with a conical outlet should be measured in m³.

Prerequisite:

- The tank can be filled or emptied. The linearization characteristic must rise continuously.
- A level calibration has been performed.



For a description of the parameters mentioned → Chap. 8.11 "Description of parameters".

Description	
1	Select the "Semi-auto. entry" option via the " Lin. mode (037) " parameter. Menu path: Setup → Extended Setup → Linearization → Lin. mode (037)
2	Select a unit via the " Unit after lin. (038) " parameter, e.g. m ³ . Menu path: Setup → Extended Setup → Linearization → Unit after lin. (038)
3	Fill the tank to the height of the 1st point.
4	Enter the number of the point in the table via the " Line numb. (039) " parameter. Menu path: Setup → Extended Setup → Linearization → Line numb. (039)
	The actual level is displayed via the " X-value (040) (manual entry) " parameter. Menu path: Setup → Extended Setup → Linearization → X-value (040) (manual entry)
	Using the " Y-value (041) (manual entry/in semi-auto. entry) " parameter, enter the associated volume value, here 0 m ³ for example, and confirm the value. Menu path: Setup → Extended Setup → Linearization → Y-value (041) (manual entry/in semi-auto. entry)
5	To enter another point in the table, select the "Next point" option via the " Edit table (042) " parameter. Enter the next point as explained in Step 4. Menu path: Setup → Extended Setup → Linearization → Edit table (042)
6	Once all the points have been entered in the table, select the "Activate table" option via the " Lin. mode (037) " parameter. Menu path: Setup → Extended Setup → Linearization → Lin. mode (037)
7	Result: The measured value after linearization is displayed.

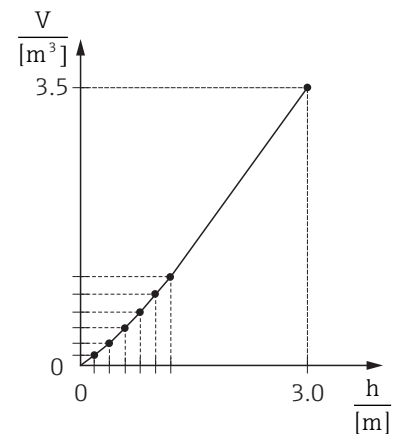
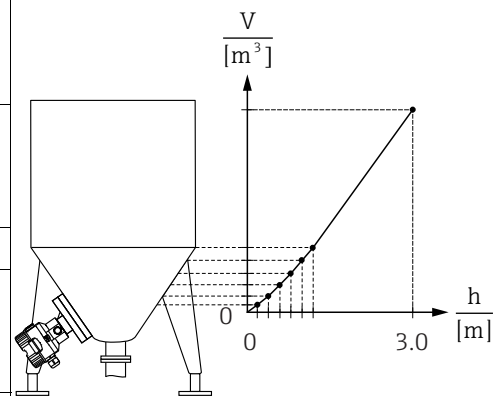









A0030032



Error message F510 "Linearization" is displayed as long as the table is being entered and is not activated.

8.5.4 Required parameters for linearization

Parameter name	Description
Lin. mode (037)	→  136
Unit after lin. (038)	→  137
Line numb. (039)	→  137
X-value (040) (manual entry)	→  137
Y-value (041) (manual entry/in semi-auto. entry)	→  137
Edit table (042)	→  137
Tank description (173)	→  137
Tank content (043)	→  137

8.6 Pressure measurement

8.6.1 Calibration without reference pressure (dry calibration)

Example:

In this example, a device with a 400 mbar (6 psi) sensor is configured for the 0 to +300 mbar (4.35 psi) measuring range, i.e. 0 mbar and 300 mbar (4.35 psi) are assigned.

Prerequisite:

This is a theoretical calibration, i.e. the pressure values for the lower and upper range are known.



Due to the orientation of the device, there may be pressure shifts in the measured value, i.e. the measured value is not zero in a pressureless condition. For information on how to perform position adjustment, see → 86. Calibration is possible only using FieldCare.

	Description
1	Select the "Pressure" measuring mode via the " Measuring mode (005) " parameter. Menu path: Setup → Measuring mode (005)
2	Select a pressure unit via the " Press. eng. unit (125) " parameter, here "mbar" for example. Menu path: Setup → Press. eng. unit (125)
3	Where necessary scale the "Output value (Out Value)" of the Analog Input Block, → 151, parameter descriptions for "Proc value scale" and "Output scale".
4	Result: The measuring range is configured for 0 to +300 mbar (4.35 psi).

8.7 Differential pressure measurement (Deltabar M)

8.7.1 Preparatory steps













Before calibrating the device, the impulse piping must be cleaned and filled with medium. → See the following table.

	Valves	Meaning	Preferred installation
1	Close 3.		
2	Fill measuring system with medium.		
	Open A, B, 2, 4.	Medium flows in.	
3	Clean impulse piping if necessary: ¹⁾ – by blowing out with compressed air in the case of gases – by rinsing out in the case of liquids.		
	Close 2 and 4.	Block off device.	
	Open 1 and 5. ¹⁾	Blow out/rinse out impulse piping.	
	Close 1 and 5. ¹⁾	Close valves after cleaning.	
4	Vent device.		
	Open 2 and 4.	Introduce medium.	
	Close 4.	Close low-pressure side.	
	Open 3.	Balance positive and low-pressure side.	
	Open 6 and 7 briefly, then close them again.	Fill device completely with medium and remove air.	
5	Set measuring point in operation.		
	Close 3.	Shut off high-pressure side from low-pressure side.	
	Open 4.	Connect low-pressure side.	
	Now – 1 ¹⁾ , 3, 5 ¹⁾ , 6 and 7 are closed. – 2 and 4 are open. – A and B open (if present).		
6	Carry out calibration if necessary. → See also page 103.		<p><i>Above: preferred installation for gases</i> <i>Below: preferred installation for liquids</i></p> <p><i>I Deltabar M</i> <i>II Three-valve manifold</i> <i>III Separator</i> <i>1, 5 Drain valves</i> <i>2, 4 Inlet valves</i> <i>3 Equalizing valve</i> <i>6, 7 Vent valves on Deltabar M</i> <i>A, B Shut-off valve</i></p>

1) for arrangement with 5 valves

8.7.2 Required parameters for differential pressure via Pressure measuring mode

Parameter name	Description
Measuring mode (005)	→  130
Switch P1/P2 (163) (Deltabar)	→  132
High-pressure side (006) (Deltabar)	→  132
Press. eng. unit (125)	→  131
Corrected press. (172)	→  133
Pos. zero adjust (007) (Deltabar and gauge pressure sensor)	→  130
Calib. offset (192)	→  130
Damping switch (164)	→  131
Damping value (017)	→  131
Pressure af. damp (111)	→  133

8.8 Flow measurement (Deltabar M)

8.8.1 Information on flow measurement

In the "Flow" measuring mode, the device determines a volume or mass flow value from the differential pressure measured. The differential pressure is generated by means of primary elements such as pitot tubes or orifice plates and depends on the volume or mass flow. Four flow types are available: volume flow, norm volume flow (European norm conditions), standard volume flow (American standard conditions), mass flow and flow in %.

In addition, the Deltabar M software provides two totalizers as standard. The totalizers integrate the volume or the mass flow. The counting function and the unit can be set separately for both totalizers. The first totalizer (totalizer 1) can be reset to zero at any time while the second (totalizer 2) totalizes the flow from commissioning onwards and cannot be reset.



The totalizers are not available for the flow type "Flow in %".

8.8.2 Preparatory steps



Before calibrating the Deltabar M, the impulse piping must be cleaned and filled with medium. → See the following table.













	Valves	Meaning	Preferred installation
1	Close 3.		
2	Fill measuring system with medium.		
	Open A, B, 2, 4.	Medium flows in.	
3	Clean impulse piping if necessary ¹⁾ : – by blowing out with compressed air in the case of gases – by rinsing out in the case of liquids.		
	Close 2 and 4.	Block off device.	
	Open 1 and 5. ¹⁾	Blow out/rinse out impulse piping.	
	Close 1 and 5. ¹⁾	Close valves after cleaning.	
4	Vent device.		
	Open 2 and 4.	Introduce medium.	
	Close 4.	Close low-pressure side.	
	Open 3.	Balance positive and low-pressure side.	
	Open 6 and 7 briefly, then close them again.	Fill device completely with medium and remove air.	
5	Carry out position zero adjustment (→ 86) if the following conditions are met. If the conditions are not met, then do not carry out the pos. zero adjustment until after step 6. Conditions: – The process cannot be blocked off. – The tapping points (A and B) are at the same geodetic height.		
6	Set measuring point in operation.		
	Close 3.	Shut off high-pressure side from low-pressure side.	
	Open 4.	Connect low-pressure side.	
	Now – 1 ¹⁾ , 3, 5 ¹⁾ , 6 and 7 are closed. – 2 and 4 are open. – A and B open (if present).		
7	Carry out position zero adjustment (→ 86) if the flow can be blocked off. In this case, step 5 is not applicable.		
8	Carry out calibration. 106, → Chap. 8.8.3.		

Above: preferred installation for gases
Below: preferred installation for liquids

- I Deltabar M
- II Three-valve manifold
- III Separator
- 1, 5 Drain valves
- 2, 4 Inlet valves
- 3 Equalizing valve
- 6, 7 Vent valves on Deltabar M
- A, B Shut-off valves

1) for arrangement with 5 valves

8.8.3 Required parameters for the "Flow" measuring mode

Parameter name	Description
Lin./SQRT switch (133) (Deltabar)	→  130
Measuring mode (005)	→  130
Switch P1/P2 (163) (Deltabar)	→  132
High-pressure side (006) (Deltabar)	→  132
Press. eng. unit (125)	→  131
Corrected press. (172)	→  133
Pos. zero adjust (007) (Deltabar and gauge pressure sensor)	→  130
Max. flow (009)	→  139
Max. pressure flow (010)	→  139
Damping switch (164)	→  131
Damping value (017)	→  131
Flow (018)	→  139
Pressure af. damp (111)	→  133

8.9 Level measurement (Deltabar M)

8.9.1 Preparatory steps

Open container



Before calibrating the device, the impulse piping must be cleaned and filled with medium. → See the following table.

	Valves	Meaning	Installation
1	Fill container to a level above the lower tap.		<p style="text-align: right; font-size: small;">A0030038</p>
2	Fill measuring system with medium.		
	Open A.	Open shut-off valve.	
3	Vent device.		
	Open 6 briefly, then close it again.	Fill device completely with medium and remove air.	
4	Set measuring point in operation.		
	Now - B and 6 are closed. - A is open.		
5	Carry out calibration according to one of the following methods:		<p><i>Open container</i></p> <ul style="list-style-type: none"> I Deltabar M II Separator 6 Vent valves on Deltabar M A Shut-off valve B Drain valve
	<ul style="list-style-type: none"> ▪ "in pressure" - with reference pressure (→ 110) ▪ "in pressure" - without reference pressure (→ 112) ▪ "in height" - with reference pressure (→ 114) ▪ "in height" - without reference pressure (→ 116) 		

Closed container



Before calibrating the device, the impulse piping must be cleaned and filled with medium. → See the following table.

Valves	Meaning	Installation	
1	Fill container to a level above the lower tap.	<p style="text-align: right;">A0030039</p>	
2	Fill measuring system with medium.		
	Close 3.		Shut off high-pressure side from low-pressure side.
	Open A and B.		Open shut-off valves.
3	Vent high-pressure side (empty low-pressure side if necessary).		
	Open 2 and 4.		Introduce medium on high-pressure side.
	Open 6 and 7 briefly, then close them again.		Fill high-pressure side completely with medium and remove air.
4	Set measuring point in operation.		
	Now		
	- 3, 6 and 7 are closed.		
	- 2, 4, A and B are open.		
5	Carry out calibration according to one of the following methods:	<p><i>Closed container</i></p> <ul style="list-style-type: none"> I Deltabar M II Three-valve manifold III Separator 1, 5 Drain valves 2, 4 Inlet valves 3 Equalizing valve 6, 7 Vent valve on Deltabar M A, B Shut-off valve 	

Closed container with superimposed steam



Before calibrating the device, the impulse piping must be cleaned and filled with medium. → See the following table.

	Valves	Meaning	Installation
1	Fill container to a level above the lower tap.		
	Fill measuring system with medium.		
	Open A and B.	Open shut-off valves.	
2	Fill the negative impulse piping to the level of the condensate trap.		
	Vent device.		
	Open 2 and 4.	Introduce medium.	
	Close 4.	Close low-pressure side.	
	Open 3.	Balance positive and low-pressure side.	
3	Open 6 and 7 briefly, then close them again.	Fill device completely with medium and remove air.	
	Set measuring point in operation.		
	Close 3.	Shut off high-pressure side from low-pressure side.	
	Open 4.	Connect low-pressure side.	
4	Now - 3, 6 and 7 are closed. - 2, 4, A and B are open.		<p><i>Closed container with superimposed steam</i></p> <ul style="list-style-type: none"> I Deltabar M II Three-valve manifold III Separator 1, 5 Drain valves 2, 4 Inlet valves 3 Equalizing valve 6, 7 Vent valves on Deltabar M A, B Shut-off valves
	Carry out calibration according to one of the following methods:		
5	<ul style="list-style-type: none"> ▪ "in pressure" - with reference pressure (→ 110) ▪ "in pressure" - without reference pressure (→ 112) ▪ "in height" - with reference pressure (→ 114) ▪ "in height" - without reference pressure (→ 116) 		

8.9.2 "In pressure" level selection Calibration with reference pressure (wet calibration)

Example:

In this example, the level in a tank should be measured in "m". The maximum level is 3 m (9.8 ft). The pressure range is due to the filling height and the density.

Prerequisite:

- The measured variable is in direct proportion to the pressure.
- The tank can be filled and emptied.



The values entered for **"Empty calib. (028)/Full calib. (031)"** and the pressures present at the device must be at least 1% apart. The value will be rejected, and a warning message displayed, if the values are too close together. Further limit values are not checked; i.e. the values entered must be appropriate for the sensor and the measuring task so that the measuring device can measure correctly.

Description	
1	Perform "position adjustment" → 86.
2	Select the "Level" measuring mode via the "Measuring mode (005)" parameter. Menu path: Setup → Measuring mode (005)
3	Select a pressure unit via the "Press. eng. unit (125)" parameter, here "mbar" for example. Menu path: Setup → Press. eng. unit (125)
4	Select the "in pressure" level mode by means of the "Level selection (024)" parameter. Menu path: Setup → Extended Setup → Level → Level selection (024)

Description	
5	Select a level unit by means of the " Unit before lin (025) " parameter, here "m" for example. Menu path: Setup → Extended Setup → Level → Unit before lin (025)
6	Select the "Wet" option by means of the " Calibration mode (027) " parameter. Menu path: Setup → Extended Setup → Level → Calibration mode (027)
7	The pressure for the lower calibration point is present at the device, here 0 mbar for example. Select the " Empty calib. (028) " parameter. Menu path: Setup → Extended Setup → Level → Empty calib. (028) Enter the level value, here 0 m for example. The pressure value present is assigned to the lower level value by confirming the value.
8	The pressure for the upper calibration point is present at the device, here 300 mbar (4.35 psi) for example. Select the " Full calib. (031) " parameter. Menu path: Setup → Extended Setup → Level → Full calib. (031) Enter the level value, here 3 m (9.8 ft) for example. The pressure value present is assigned to the upper level value by confirming the value.
9	If calibration is performed with a medium other than the process medium, enter the density of the calibration medium in " Adjust density (034) ". Menu path: Setup → Extended Setup → Level → Adjust density (034)
10	If calibration was performed with a medium other than the process medium, specify the density of the process medium in the " Process density (035) " parameter. Menu path: Setup → Extended setup → Level → Process density (035) .
11	Result: The measuring range is set for 0 to 3 m (9.8 ft).

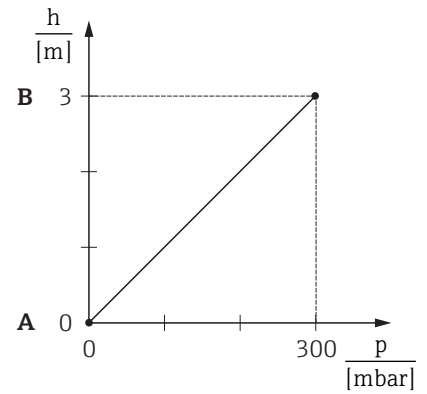

Fig. 37: Calibration with reference pressure - wet calibration

A0017658

A See Table, Step 7.
B See Table, Step 8.



The measured variables %, level, volume and mass are available for this level mode. See → 134 "**Unit before lin (025)**".

8.9.3 "In pressure" level selection Calibration without reference pressure (dry calibration)

Example:

In this example, the volume in a tank should be measured in liters. The maximum volume of 1000 liters (264 gal) corresponds to a pressure of 450 mbar (6.53 psi). The minimum volume of 0 liters corresponds to a pressure of 50 mbar (0.72 psi) since the device is mounted below the start of the level measuring range.

Prerequisite:

- The measured variable is in direct proportion to the pressure.
- This is a theoretical calibration i.e. the pressure and volume values for the lower and upper calibration point must be known.



- The values entered for "**Empty calib. (028)/Full calib. (031)**", "**Empty pressure (029)/Full pressure (032)**" must be at least 1% apart. The value will be rejected, and a warning message displayed, if the values are too close together. Further limit values are not checked; i.e. the values entered must be appropriate for the sensor and the measuring task so that the measuring device can measure correctly.
- Due to the orientation of the device, there may be pressure shifts in the measured value, i.e. when the container is empty or partly filled, the measured value is not zero. For information on how to perform position adjustment, see → 86, "Position zero adjustment".

Description	
1	Select the "Level" measuring mode via the " Measuring mode (005) " parameter. Menu path: Setup → Measuring mode (005)
2	Select a pressure unit via the " Press. eng. unit (125) " parameter, here "mbar" for example. Menu path: Setup → Press. eng. unit (125)
3	Select the "in pressure" level mode by means of the " Level selection (024) " parameter. Menu path: Setup → Extended Setup → Level → Level selection (024)
4	Select a volume unit via the " Unit before lin (025) " parameter, here "l" (liter) for example. Menu path: Setup → Extended Setup → Level → Unit before lin (025)

Description	
5	Select the "Dry" option by means of the " Calibration mode (027) " parameter. Menu path: Setup → Extended Setup → Level → Calibration mode (027)
6	" Adjust density (034) " contains the factory setting 1.0, but this value can be changed if required. The entered value pairs must correspond to this density. Menu path: Setup → Extended Setup → Level → Adjust density (034)
7	Enter the volume value for the lower calibration point via the " Empty calib. (028) " parameter, here 0 liters for example. Menu path: Setup → Extended Setup → Level → Empty calib. (028)
8	Enter the pressure value for the lower calibration point via the " Empty pressure (029) " parameter, here 50 mbar (0.72 psi) for example. Menu path: Setup → Extended Setup → Level → Empty pressure (029)
9	Enter the volume value for the upper calibration point via the " Full calib. (031) " parameter, here 1000 liters (264 gal) for example. Menu path: Setup → Extended Setup → Level → Full calib. (031)
10	Enter the pressure value for the upper calibration point via the " Full pressure (032) " parameter, here 450 mbar (6.53 psi) for example. Menu path: Setup → Extended Setup → Level → Full pressure (032)
11	If calibration was performed with a medium other than the process medium, specify the density of the process medium in the " Process density (035) " parameter. Menu path: Setup → Extended setup → Level → Process density (035) .
12	Result: The measuring range is set for 0 to 1000 l (264 gal).

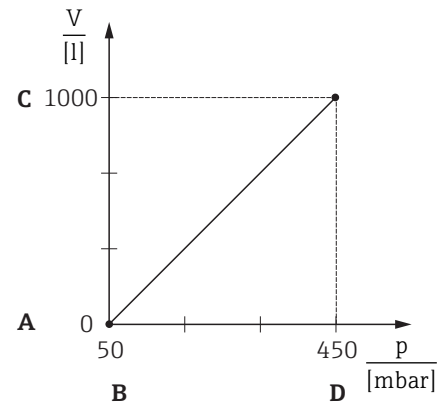

Fig. 38: Calibration without reference pressure – dry calibration

A0031194

- A See Table, Step 7.
- B See Table, Step 8.
- C See Table, Step 9.
- D See Table, Step 10.



The measured variables %, level, volume and mass are available for this level mode.
See → 134 "**Unit before lin (025)**".

8.9.4 "In height" level selection Calibration without reference pressure (dry calibration)

Example:

In this example, the volume in a tank should be measured in liters. The maximum volume of 1000 liters (264 gal) corresponds to a level of 4.5 m (14.8 ft). The minimum volume of 0 liters corresponds to a level of 0.5 m (1.6 ft) since the device is mounted below the start of the level measuring range.

Prerequisite:

- The measured variable is in direct proportion to the pressure.
- This is a theoretical calibration i.e. the height and volume values for the lower and upper calibration point must be known.



- The values entered for "**Empty calib. (028)/Full calib. (031)**", "**Empty height (030)/Full height (033)**" must be at least 1% apart. The value will be rejected, and a warning message displayed, if the values are too close together. Further limit values are not checked; i.e. the values entered must be appropriate for the sensor and the measuring task so that the measuring device can measure correctly.
- Due to the orientation of the device, there may be pressure shifts in the measured value, i.e. when the container is empty or partly filled, the measured value is not zero. For information on how to perform position adjustment, see → 86, "Position zero adjustment".

	Description
1	Select the "Level" measuring mode via the " Measuring mode (005) " parameter. Menu path: Setup → Measuring mode (005)
2	Select a pressure unit via the " Press. eng. unit (125) " parameter, here "mbar" for example. Menu path: Setup → Press. eng. unit (125)
3	Select the "in height" level mode via the " Level selection (024) " parameter. Menu path: Setup → Extended Setup → Level → Level selection (024)
4	Select a volume unit via the " Unit before lin (025) " parameter, here "l" (liter) for example. Menu path: Setup → Extended Setup → Level → Unit before lin (025)
5	Select a level unit by means of the " Height unit (026) " parameter, here "m" for example. Menu path: Setup → Extended Setup → Level → Height unit (026)
6	Select the "Dry" option by means of the " Calibration mode (027) " parameter. Menu path: Setup → Extended Setup → Level → Calibration mode (027)
7	Enter the density of the medium via the " Adjust density (034) " parameter, here "1 g/cm ³ " (1 SGU) for example. Menu path: Setup → Extended Setup → Level → Adjust density (034)

Description	
8	<p>Enter the volume value for the lower calibration point via the "Empty calib. (028)" parameter, here 0 liters for example.</p> <p>Menu path: Setup → Extended Setup → Level → Empty calib. (028)</p>
9	<p>Enter the height value for the lower calibration point via the "Empty height (030)" parameter, here 0.5 m (1.6 ft) for example.</p> <p>Menu path: Setup → Extended Setup → Level → Empty height (030)</p>
10	<p>Enter the volume value for the upper calibration point via the "Full calib. (031)" parameter, here 1000 liters (264 gal) for example.</p> <p>Menu path: Setup → Extended Setup → Level → Full calib. (031)</p>
11	<p>Enter the height value for the upper calibration point via the "Full height (033)" parameter, here 4.5 m (14.8 ft) for example.</p> <p>Menu path: Setup → Extended Setup → Level → Full height (033)</p>
12	<p>If the process uses a medium other than that on which the calibration was based, the new density must be specified in the "Process density (035)" parameter.</p> <p>Menu path: Setup → Extended setup → Level → Process density (035).</p>
13	<p>Result: The measuring range is set for 0 to 1000 l (264 gal).</p>

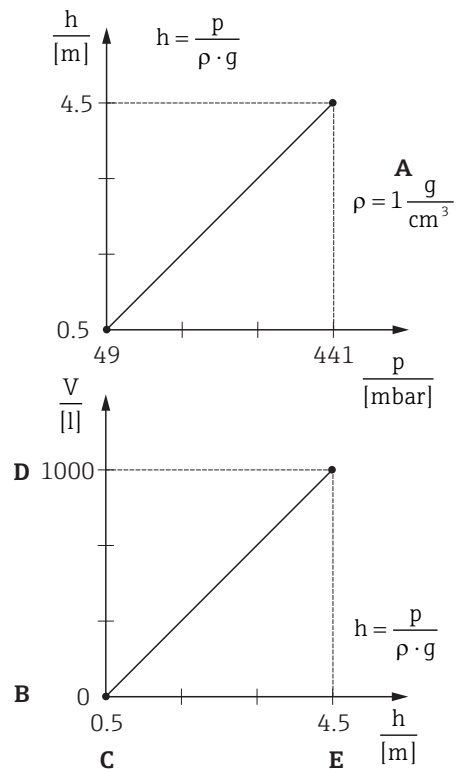

Fig. 39: Calibration without reference pressure - dry calibration

- A See Table, Step 7.
- B See Table, Step 8.
- C See Table, Step 9.
- D See Table, Step 10.
- E See Table, Step 11.



The measured variables %, level, volume and mass are available for this level mode → 134 **"Unit before lin (025)"**.

8.9.5 "In height" level selection Calibration with reference pressure (wet calibration)

Example:

In this example, the volume in a tank should be measured in liters. The maximum volume of 1000 liters (264 gal) corresponds to a level of 4.5 m (14.8 ft). The minimum volume of 0 liters corresponds to a level of 0.5 m (1.6 ft) since the device is mounted below the start of the level measuring range.

The density of the medium is 1 g/cm³ (1 SGU).

Prerequisite:

- The measured variable is in direct proportion to the pressure.
- The tank can be filled and emptied.



The values entered for **"Empty calib. (028)/Full calib. (031)"** and the pressure values present at the device must be at least 1% apart. The value will be rejected, and a warning message displayed, if the values are too close together. Further limit values are not checked; i.e. the values entered must be appropriate for the sensor and the measuring task so that the measuring device can measure correctly.

	Description
1	Perform position adjustment. See → 86.
2	Select the "Level" measuring mode via the "Measuring mode (005)" parameter. Menu path: Setup → Measuring mode (005)
3	Select a pressure unit via the "Press. eng. unit (125)" parameter, here "mbar" for example. Menu path: Setup → Press. eng. unit (125)
4	Select the "in height" level mode via the "Level selection (024)" parameter. Menu path: Setup → Extended Setup → Level → Level selection (024)
5	Select a volume unit via the "Unit before lin (025)" parameter, here "l" (liter) for example. Menu path: Setup → Extended Setup → Level → Unit before lin (025)

Description	
6	Select a level unit by means of the "Height unit (026)" parameter, here "m" for example. Menu path: Setup → Extended Setup → Level → Height unit (026)
7	Select the "Wet" option by means of the "Calibration mode (027)" parameter. Menu path: Setup → Extended Setup → Level → Calibration mode (027)
8	If calibration is performed with a medium other than the process medium, enter the density of the calibration medium in the "Adjust density (034)" parameter, here 1 g/cm ³ (1 SGU) for example. Menu path: Setup → Extended Setup → Level → Adjust density (034)
9	The pressure for the lower calibration point is present at the device, here 0.5 m covered / 49 mbar (0.71 psi) for example. Enter the volume value for the lower calibration point via the "Empty calib. (028)" parameter, here 0 liters for example. Menu path: Setup → Extended Setup → Level → Empty calib. (028)
	The pressure for the upper calibration point is present at the device, here 4.5 m covered / 441 mbar (6.4 psi) for example. Enter the volume value for the upper calibration point via the "Full calib. (031)" parameter, here "1000 liters" (264 gal) for example. Menu path: Setup → Extended Setup → Level → Full calib. (031)
11	If calibration was performed with a medium other than the process medium, specify the density of the process medium in the "Process density (035)" parameter. Menu path: Setup → Extended Setup → Level → Process density (035)
12	Result: The measuring range is set for 0 to 1000 l (264 gal).

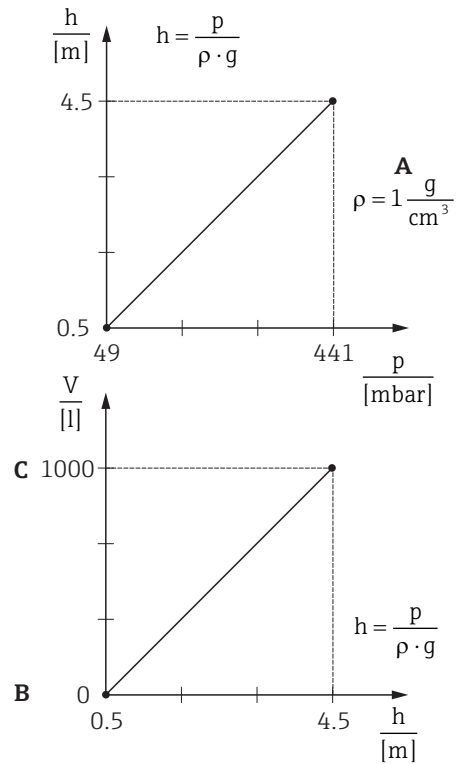

Fig. 40: Calibration with reference pressure - wet calibration

- A See Table, Step 8.
- B See Table, Step 9.
- C See Table, Step 10.



The measured variables %, level, volume and mass are available for this level mode → 134 "Unit before lin (025)".

8.9.6 Required parameters for Level measuring mode

Parameter name	Description
Level selection (024)	→ 134
Unit before lin (025)	134
Height unit (026)	134
Calibration mode (027)	134
Empty calib. (028)	135
Empty pressure (029) <i>Empty pressure (185)</i>	135
Empty height (030) <i>Empty height (186)</i>	135
Full calib. (031)	135
Full pressure (187) <i>Full pressure (032)</i>	135
Full height (033) <i>Full height (188)</i>	135
Density unit (127)	136
Adjust density (034)	136
Process density (035)	136
Level before lin. (019)	136

8.10 Overview of the onsite display operating menu

All parameters and their direct access code (in brackets) are listed in the following table. The page number refers to where a description of the parameter can be found.

Level 1	Level 2	Level 3	Level 4	Page		
Parameters in italics cannot be edited (read only). Specific settings, such as the Measuring mode (005) , dry or wet calibration, or hardware locking, determine whether these parameters are displayed.						
Language (000)				→ 128		
Display/operat.	Display mode (001)			→ 128		
	Add. disp. value (002)			→ 128		
	Format 1st value (004)			→ 129		
	Format ext. val. 1 (235)			→ 129		
	Format ext. val. 2 (258)			→ 129		
Setup	Lin./SQRT switch (133) (Deltabar)			→ 130		
	Measuring mode (005) <i>Measuring mode (182)</i>			→ 130		
	Switch P1/P2 (163) (Deltabar)			→ 132		
	High-pressure side (183) (Deltabar) <i>High-pressure side (006) (Deltabar)</i>			→ 132		
	Press. eng. unit (125)			→ 131		
	Corrected press. (172)			→ 133		
	Pos. zero adjust (007) (Deltabar and gauge pressure sensor) Calib. offset (192) (absolute pressure sensors)			→ 130 → 130		
	Max. flow (009) ("Flow" measuring mode) (Deltabar)			→ 139		
	Max. pressure flow (010) ("Flow" measuring mode) (Deltabar)			→ 139		
	Empty calib. (011) ("Level" measuring mode and "Calibration mode (027)" = wet)			→ 135		
	Full calib. (012) ("Level" measuring mode and "Calibration mode (027)" = wet)			→ 135		
	Damping switch (164) (read only)			→ 131		
	Damping value (184) <i>Damping value (017)</i>			→ 131		
	Flow (018) ("Flow" measuring mode) (Deltabar)			→ 139		
	Level before lin. (019) ("Level" measuring mode)			→ 136		
	Pressure af. damp (111)			→ 133		
	Extended setup	Code definition (023)			→ 127	
		Device tag (022)			→ 128	
		Ident number sel (229)			→ 140	
		Operator code (021)			→ 127	
		Level (Level measuring mode)	Level selection (024)			→ 134
			Unit before lin (025)			134
			Height unit (026)			134
Calibration mode (027)			134			
Empty calib. (028)			135			
Empty pressure (029) <i>Empty pressure (185)</i>			135			
Empty height (030) <i>Empty height (186)</i>			135			
...	Full calib. (031)	135		

Level 1	Level 2	Level 3	Level 4	Page
... Setup	... Extended setup	... Level (Level measuring mode)	Full pressure (187) <i>Full pressure (032)</i>	135
			Full height (033) <i>Full height (188)</i>	135
			Density unit (127)	136
			Adjust density (034)	136
			Process density (035)	136
			Level before lin. (019)	136
		Linearization	Lin. mode (037)	136
			Unit after lin. (038)	137
			Line numb. (039)	137
			X-value (040) (manual entry) <i>X-value (123) (in linear/activ table)</i>	137
			Y-value (041) (manual entry/in semi- auto. entry) <i>Y-value (194) (in linear/activ table)</i>	137
			Edit table (042)	137
			Tank description (173)	137
			Tank content (043)	137
		Flow ("Flow" measuring mode) (Deltabar)	Flow type (044)	138
			Mass flow unit (045)	138
			Norm. flow unit (046)	138
			Std. flow unit (047)	138
			Flow unit (048)	139
			Max. flow (009)	139
			Max. pressure flow (010)	139
			Set low-flow cut-off (049)	139
			Flow (018)	139
		Analog input 1	Channel (171)	140
			Output value (Out Value) (224)	141
			Status (196)	141
			Filt. time const. (197)	141
			Fail safe mode (198)	141
			Failsafe default (199)	141
		Analog input 2	Channel (230) (Cerabar/Deltapilot)	141
			Channel (231) (Deltabar)	141
			Output value (Out Value) (201)	141
			Status (202)	141
			Filt. time const. (203)	141
			Fail safe mode (204)	141
			Failsafe default (205)	141
		Analog output 1	Fail safe time (206)	142
			Fail safe mode (207)	142
			Failsafe default (208)	142
			Input value (209)	142
	

Level 1	Level 2	Level 3	Level 4	Page		
... Setup	... Extended setup	... Analog output 1	Input status (220)	142		
			Unit (211)	142		
		Analog output 2	Fail safe time (212)	142		
			Fail safe mode (213)	142		
			Failsafe default (214)	142		
			Input value (215)	142		
			Input status (223)	142		
			Unit (217)	143		
		Totalizer 1 (Deltabar)	Channel (218)	143		
			Eng. unit total.1 (058) (059) (060) (061)	143		
			Totalizer 1 mode (175)	143		
			Total. 1 failsafe (221)	143		
			Total.1 value (219)	143		
			Preset value (222)	143		
			Totalizer 1 (261)	143		
		Status (236)	144			
		Totalizer 2 (Deltabar)	Eng. unit totalizer 2 (065) (066) (067) (068)	144		
			Totalizer 2 mode (177)	144		
			Total. 2 failsafe (178)	145		
			Totalizer 2 (069)	145		
				Totalizer 2 overflow (070)	145	
		Diagnosis	Diagnostic code (071)			145
			Last diag. code (072)			145
Min. meas. press. (073)			145			
Max. meas. press. (074)			145			
Diagnostic list	Diagnostic 1 (075)			146		
	Diagnostic 2 (076)			146		
	Diagnostic 3 (077)			146		
	Diagnostic 4 (078)			146		
	Diagnostic 5 (079)			146		
	Diagnostic 6 (080)			146		
	Diagnostic 7 (081)			146		
	Diagnostic 8 (082)			146		
	Diagnostic 9 (083)			146		
	Diagnostic 10 (084)			146		
Event logbook	Last diag. 1 (085)			146		
	Last diag. 2 (086)			146		
	Last diag. 3 (087)			146		
	Last diag. 4 (088)			146		
	Last diag. 5 (089)			146		
	Last diag. 6 (090)			146		
	Last diag. 7 (091)			146		

Level 1	Level 2	Level 3	Level 4	Page	
...	...	Last diag. 8 (092)		146	
... Diagnosis	... Event log	Last diag. 9 (093)		146	
		Last diag. 10 (094)		146	
	Instrument info	Firmware version (095)		128	
		Serial number (096)		128	
		Ext. order code (097)		128	
		Order code (098)		128	
		Device tag (022)		128	
		ENP version (099)		128	
		Config. counter (100)		146	
		LRL sensor (101)		139	
		URL sensor (102)		139	
		Ident number (225)		140	
	Measured values	Flow (018)		139	
		Level before lin. (019)		136	
		Tank content (043)		137	
		Meas. pressure (020)		132	
		Sensor pressure (109)		133	
		Corrected press. (172)		133	
		Pressure af. damp (111)		133	
		Sensor temp. (110) (Cerabar/Deltapilot)		131	
		Analog input 1	Channel (171)		140
			Output value (Out Value) (224)		141
			Status (196)		141
		Analog input 2	Channel (230) (Cerabar/Deltapilot)		141
			Channel (231) (Deltabar)		141
			Output value (Out Value) (201)		141
			Status (202)		141
		Analog output 1	Input value (209)		142
			Input status (220)		142
		Analog output 2	Input value (215)		142
			Input status (223)		142
		Totalizer 1 (Deltabar)	Channel (218)		143
			Totalizer 1 (261)		144
			Status (236)		144
		Totalizer 2 (Deltabar)	Totalizer 2 (069)		145
	Totalizer 2 overflow (070)			145	
	Simulation	Simulation mode (112)		146	
		Sim. pressure (113)		147	
		Sim. flow (114) (Deltabar)		147	
		Sim. level (115)		148	
		Sim. tank cont. (116)		148	
		Sim. error no. (118)		148	

Level 1	Level 2	Level 3	Level 4	Page	
	Reset	Enter reset code (124)		129	
Expert	Direct access (119)			127	
	System	Code definition (023)		127	
		Lock switch (120)		127	
		Operator code (021)		127	
		Instrument info	Device tag (022)		128
			Serial number (096)		128
			Firmware version (095)		128
			Ext. order code (097)		128
			Order code (098)		128
			ENP version (099)		128
			Electr. serial no. (121)		128
			Sensor serial no. (122)		128
		Display	Language (000)		128
			Display mode (001)		128
			Add. disp. value (002)		128
			Format 1st value (004)		129
			Format ext. val. 1 (235)		129
			Format ext. val. 2 (258)		129
		Management	Enter reset code (124)		129
			Download select.		129
	Measurement	Lin./SQRT switch (133) (Deltabar)		130	
		Measuring mode (005) <i>Measuring mode (182)</i>		130	
		Basic setup	Pos. zero adjust (007) (Deltabar and gauge pressure sensor)		130
			Calib. offset (192) Calib. offset (008)		130
			Damping switch (164) (read only)		131
			Damping value (184) <i>Damping value (017)</i>		131
			Press. eng. unit (125)		131
			Temp. eng. unit. (126) (Cerabar/ Deltapilot)		131
			Sensor temp. (110) (Cerabar/ Deltapilot)		131
		Pressure	Switch P1/P2 (163) (Deltabar)		132
			High-pressure side (183) (Deltabar) <i>High-pressure side (006) (Deltabar)</i>		132
			Meas. pressure (020)		132
			Sensor pressure (109)		133
Corrected press. (172)				133	
Pressure af. damp (111)				133	
Level		Level selection (024)		134	
		Unit before lin (025)		134	
		Height unit (026)		134	

Level 1	Level 2	Level 3	Level 4	Page	
...	Calibration mode (027)	134	
...	Empty calib. (028)	135	
... Expert	... Measurement	... Level	Empty pressure (185) Empty pressure (029)	135	
			Empty height (030) Empty height (186)	135	
			Full calib. (031)	135	
			Full pressure (187) Full pressure (032)	135	
			Full height (033) Full height (188)	135	
			Density unit (127)	136	
			Adjust density (034)	136	
			Process density (035)	136	
			Level before lin. (019)	136	
			Linearization	Lin. mode (037)	136
				Unit after lin. (038)	137
				Line numb. (039)	137
		X-value (040) (manual entry) X-value (123) (in linear/activ table)		137	
		Y-value (041) (manual entry/in semi-auto. entry) Y-value (194) (in linear/activ table)		137	
		Edit table (042)		137	
		Tank description (173)		137	
		Tank content (043)		137	
		Flow (Deltabar)	Flow type (044)	138	
			Mass flow unit (045)	138	
			Norm. flow unit (046)	138	
			Std. flow unit (047)	138	
			Flow unit (048)	139	
			Max. flow (009)	139	
			Max. pressure flow (010)	139	
			Set low-flow cut-off (049)	139	
			Flow (018)	139	
		Sensor limits	LRL sensor (101)	139	
			URL sensor (102)	139	
		Sensor trim	Lo trim measured (129)	140	
			Hi trim measured (130)	140	
			Lo trim sensor (131)	140	
			Hi trim sensor (132)	140	
		Communication	PB-PA Info	Ident number (225)	140
				Profile revision (227)	140
			PB-PA Config	Addressing (228)	140
				Bus address (233)	140
	Ident number sel (229)			140	

Level 1	Level 2	Level 3	Level 4	Page		
...	...		Cond.status diag (234)	140		
...	...	Analog input 1	Channel (171)	→ 140		
... Expert	... Communication	... Analog input 1	Output value (Out Value) (224)	141		
			Status (196)	141		
			Filt. time const. (197)	141		
			Fail safe mode (198)	141		
			Failsafe default (199)	141		
		Analog input 2	Channel (230) (Cerabar/Deltapilot)	141		
			Channel (231) (Deltabar)	141		
			Output value (Out Value) (201)	141		
			Status (202)	141		
			Filt. time const. (203)	141		
			Fail safe mode (204)	141		
			Failsafe default (205)	141		
		Analog output 1	Fail safe time (206)	142		
			Fail safe mode (207)	142		
			Failsafe default (208)	142		
			Input value (209)	142		
			Input status (220)	142		
			Unit (211)	142		
		Analog output 2	Fail safe time (212)	142		
			Fail safe mode (213)	142		
			Failsafe default (214)	142		
			Input value (215)	142		
			Input status (223)	142		
			Unit (217)	143		
		Totalizer 1 (Deltabar)	Channel (218)	143		
			Eng.unit total.1 (058) (059) (060) (061)	143		
			Totalizer 1 mode (175)	→ 143		
			Total. 1 failsafe (221)	143		
			Total.1 value (219)	143		
			Preset value (222)	143		
			Totalizer 1 (261)	144		
			Status (236)	144		
		Application	Electr. Delta P (158) (Cerabar / Deltapilot)		→ 144	
			Fixed ext. value (174) (Cerabar / Deltapilot)		→ 144	
			Ext. val. 2 (259)		→ 144	
			Ext. val. 2 status (260)		→ 144	
			Totalizer 2 (Deltabar)	Eng. unit totalizer 2 (065) (066) (067) (068)		144
				Totalizer 2 mode (177)		144
				Total. 2 failsafe (178)		145
				Totalizer 2 (069)		145

Level 1	Level 2	Level 3	Level 4	Page
			Totalizer 2 overflow (070)	145
	Diagnosis	Diagnostic code (071)		145
...	...	Last diag. code (072)		145
... Expert	... Diagnosis	Reset logbook (159)		145
		Min. meas. press. (073)		145
		Max. meas. press. (074)		145
		Reset peakhold (161)		145
		Alarm behav. P (050)		145
		Operating hours (162)		146
		Config. counter (100)		146
		Diagnostic list	Diagnostic 1 (075)	146
			Diagnostic 2 (076)	146
			Diagnostic 3 (077)	146
			Diagnostic 4 (078)	146
			Diagnostic 5 (079)	146
			Diagnostic 6 (080)	146
			Diagnostic 7 (081)	146
			Diagnostic 8 (082)	146
			Diagnostic 9 (083)	146
			Diagnostic 10 (084)	146
		Event logbook	Last diag. 1 (085)	146
			Last diag. 2 (086)	146
			Last diag. 3 (087)	146
			Last diag. 4 (088)	146
			Last diag. 5 (089)	146
			Last diag. 6 (090)	146
			Last diag. 7 (091)	146
			Last diag. 8 (092)	146
			Last diag. 9 (093)	146
			Last diag. 10 (094)	146
		Simulation	Simulation mode (112)	146
			Sim. pressure (113)	147
			Sim. flow (114) (Deltabar)	147
			Sim. level (115)	148
			Sim. tank cont. (116)	148
			Sim. error no. (118)	148

8.11 Description of parameters



This section describes the parameters in the order they are arranged in the "Expert" operating menu.

Expert

Parameter name	Description
Direct access (119) Entry	Enter the direct access code to go directly to a parameter. Options: <ul style="list-style-type: none"> ▪ A number between 0 and 999 (only valid entries are recognized) Factory setting: 0 Note: For direct access, it is not necessary to enter leading zeros.

8.11.1 System

Expert → System

Parameter name	Description
Code definition (023) Entry	Use this function to enter the release code that will be used to unlock the device. Options: <ul style="list-style-type: none"> ▪ A number between 0 and 9999 Factory setting: 0
Lock switch (120) Display	Displays the status of DIP switch 1 (on) on the electronic insert. You can lock or unlock parameters relevant to the measured value with DIP switch 1. If operation is locked by means of the " Operator code (021) " parameter, you can only unlock operation again by means of this parameter. Display: <ul style="list-style-type: none"> ▪ On (locking switched on) ▪ Off (locking switched off) Factory setting: Off (locking switched off)
Operator code (021) Entry	Use this function to enter a code to lock or unlock the device operation. Options: <ul style="list-style-type: none"> ▪ To lock: Enter a number ≠ the release code. ▪ To unlock: Enter the release code.  The release code is "0" in the default configuration. Another release code can be defined in the " Code definition (023) " parameter. If the user has forgotten the release code, it can be made visible again by entering the number sequence "5864". Factory setting: 0

Expert → System → Instrument info

Parameter name	Description
Device tag (022) Entry	Enter the device tag (max. 32 alphanumeric characters). Factory setting As per order specifications
Serial number (096) Display	Displays the serial number of the device (11 alphanumeric characters).
Firmware version (095) Display	Displays the firmware version.
Ext. order code (097) Display	Displays the extended order code (max. 60 alphanumeric characters). Factory setting As per order specifications
Order code (098) Display	Displays the order code (max. 20 alphanumeric characters). Factory setting As per order specifications
ENP version (099) Display	Displays the ENP version (ENP = electronic nameplate)
Electr. serial no. (121) Display	Displays the serial number of the main electronics (11 alphanumeric characters).
Sensor serial no. (122) Display	Displays the serial number of the sensor (11 alphanumeric characters).

Expert → System → Display

Parameter name	Description
Language (000) Options	Select the language for the onsite display. Options: <ul style="list-style-type: none"> ▪ English ▪ One further language (language of the manufacturing plant) ▪ Possibly another language (as selected when ordering the device) Factory setting: English
Display mode (001) Options	Specify the contents for the first line of the onsite display in the measuring mode. Options: <ul style="list-style-type: none"> ▪ Main value only (value+bar graph) ▪ Ext. value1 only (value+status) ▪ All alternating (main value+secondary value+Ext. value 1+Ext. value 2) Ext. value 1 and Ext. value 2 are only displayed if the PLC sends these values via the analog output blocks to the device. Factory setting: Main value only
Add. disp. value (002) Options	Specify the contents for the second line of the onsite display in the measuring mode. Options: <ul style="list-style-type: none"> ▪ No value ▪ Pressure ▪ Main value (%) ▪ Totalizer 1 (Deltabar M) ▪ Totalizer 2 (Deltabar M) ▪ Temperature (Cerabar/Deltapilot) The options depend on the measuring mode chosen. Factory setting: No value

Parameter name	Description
Format 1st value (004) Options	Specify the number of places after the decimal point for the value displayed in the main line for the primary value. Options: <ul style="list-style-type: none"> ■ Auto ■ x ■ x.x ■ x.xx ■ x.xxx ■ x.xxxx ■ x.xxxxx Factory setting: Auto
Format ext. val. 1 (235) Options	Specify the number of places after the decimal point for the value displayed in the main line for the external value 1. Options: <ul style="list-style-type: none"> ■ x.x ■ x.xx ■ x.xxx ■ x.xxxx ■ x.xxxxx Factory setting: x.x
Format ext. val. 2 (258) Options	Specify the number of places after the decimal point for the value displayed in the main line for the external value 2. Options: <ul style="list-style-type: none"> ■ x.x ■ x.xx ■ x.xxx ■ x.xxxx ■ x.xxxxx Factory setting: x.x

Expert → System → Management

Parameter name	Description
Enter reset code (124) Entry	Reset parameters completely or partially to the factory values or order configuration by entering a reset code, → 56, "Resetting to factory settings (reset)". Factory setting: 0
Download select. Display	Select the data records for the upload/download function in Fieldcare and PDM. Prerequisite: DIP switches are set to the "SW" setting and "Damping" is set to "On". A download with the "Configuration copy" factory setting causes the device to download all the parameters required for a measurement. The "Electronics replace" setting only takes effect if an appropriate release code is entered in the "Operator code" parameter. Options: <ul style="list-style-type: none"> ■ Configuration copy: With this option, general configuration parameters are overwritten except for the serial number, order number, calibration, position adjustment, application and tag information. ■ Device replacement: With this option, general configuration parameters are overwritten except for the serial number, order number, calibration and position adjustment. ■ Electronics replace: With this option, general configuration parameters are overwritten. Factory setting: Configuration copy

8.11.2 Measurement

Expert → Measurement



Parameter name	Description
Lin./SQRT switch (133) (Deltabar) Display	Displays the status of DIP switch 4 on the electronic insert, which is used to define the output characteristics of the current output. Display: <ul style="list-style-type: none"> ▪ SW setting The output characteristic depends on the measuring mode; default = "linear". ▪ Square root The flow measurement is active and the square root signal is used. Factory setting SW setting
Measuring mode (005) Measuring mode (182) Options	Select the measuring mode. The operating menu is structured differently depending on the measuring mode selected. <div style="background-color: #ffcc00; padding: 2px;">⚠ WARNING</div> Changing the measuring mode affects the span (URV)! This situation can result in product overflow. <ul style="list-style-type: none"> ▶ If the measuring mode is changed, the span setting (URV) must be verified and, if necessary, reconfigured! Options: <ul style="list-style-type: none"> ▪ Pressure ▪ Level ▪ Flow (Deltabar M only) Factory setting Pressure or as per order specifications

Expert → Measurement → Basic setup

Parameter name	Description
Pos. zero adjust (007) (Deltabar and gauge pressure sensor) Options	Position adjustment – the pressure difference between zero (set point) and the measured pressure doesn't need to be known. Example: <ul style="list-style-type: none"> – Measured value = 2.2 mbar (0.032 psi) – Correct the measured value via the "Pos. zero adjust (007) (Deltabar and gauge pressure sensor)" parameter with the "Confirm" option. This means that you are assigning the value 0.0 to the pressure present. – Measured value (after pos. zero adjust) = 0.0 mbar Options <ul style="list-style-type: none"> ▪ Confirm ▪ Abort Factory setting: Abort
Calib. offset (192) Calib. offset (008) Entry	Position adjustment – the pressure difference between the set point and the measured pressure must be known. Example: <ul style="list-style-type: none"> – Measured value = 982.2 mbar (14.25 psi) – You correct the measured value with the value entered (e.g. 2.2 mbar (0.032 psi)) via the "Calib. offset (192)" parameter. This means that you are assigning the value 980.0 (14.21 psi) to the pressure present. – Measured value (after pos. zero adjust) = 980.0 mbar (14.21 psi) Factory setting: 0.0

Parameter name	Description
Damping switch (164) Display	<p>Displays the switch position of DIP switch 2 which is used to switch the damping of the output signal on and off.</p> <p>Display:</p> <ul style="list-style-type: none"> ▪ Off The output signal is not damped. ▪ On The output signal is damped. The attenuation constant is specified in the "Damping value (184)" parameter <p>Factory setting On</p>
Damping value (017) Damping value (184) Entry	<p>Enter damping time (time constant τ). The damping affects the speed at which the measured value reacts to changes in pressure.</p> <p>Input range: 0.0 to 999.0 s</p> <p>Factory setting: 2.0 or as per order specifications</p>
Press. eng. unit (125) Options	<p>Select the pressure unit. If a new pressure unit is selected, all pressure-specific parameters are converted and displayed with the new unit.</p> <p>Options:</p> <ul style="list-style-type: none"> ▪ mbar, bar ▪ mmH₂O, mH₂O, ▪ inH₂O, ftH₂O ▪ Pa, kPa, MPa ▪ psi ▪ mmHg, inHg ▪ kgf/cm² <p>Factory setting: mbar or bar depending on the sensor nominal measuring range, or as per order specifications</p>
Temp. eng. unit. (126) (Cerabar/Deltapilot) Options	<p>Select the unit for the temperature measured values.</p> <p></p> <p>The setting affects the unit for the "Sensor temp. (110)" parameter.</p> <p>Options:</p> <ul style="list-style-type: none"> ▪ °C ▪ °F ▪ K <p>Factory setting: °C</p>
Sensor temp. (110) (Cerabar/Deltapilot) Display	<p>Displays the temperature currently measured in the sensor. This can deviate from the process temperature.</p>

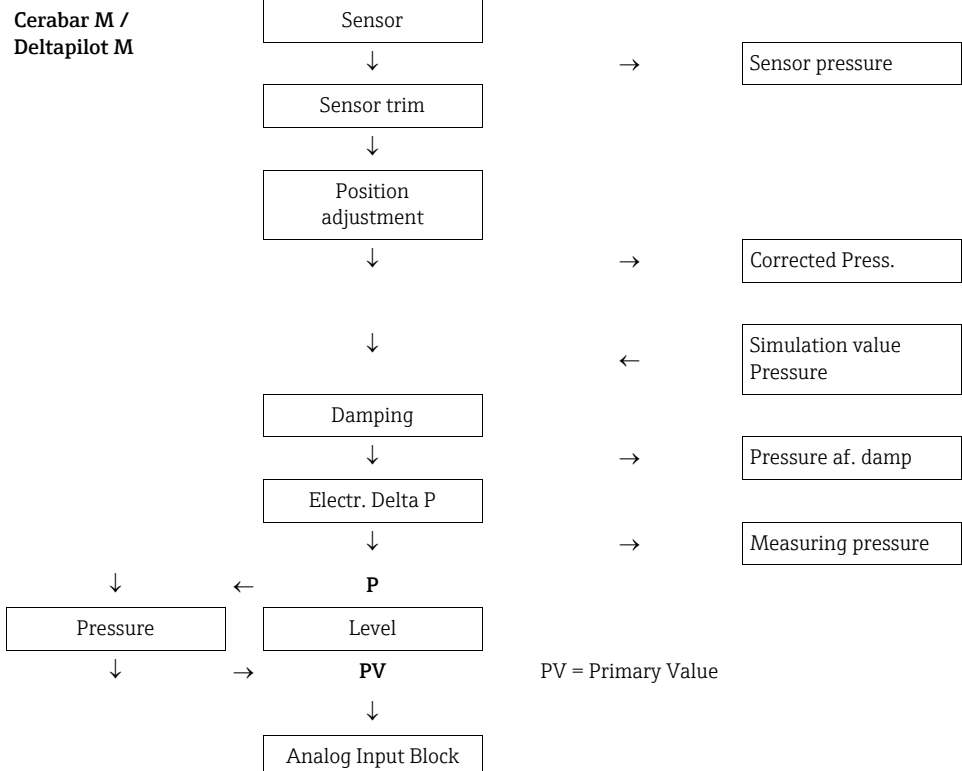

Expert → Measurement → Pressure

Parameter name	Description
Switch P1/P2 (163) (Deltabar) Display	Indicates whether the "SW/P2 High" DIP switch (DIP switch 5) is switched on.  The "SW/P2 High" DIP switch determines which pressure input corresponds to the high-pressure side. Display: <ul style="list-style-type: none"> SW setting "SW/P2 High" is switched off: The "High-pressure side (183) (Deltabar)" parameter determines which pressure input corresponds to the high-pressure side. P2 High "SW/P2 High" is switched on: Pressure input P2 corresponds to the high-pressure side, independent of the setting in the "High-pressure side (183) (Deltabar)" parameter. Factory setting: SW setting
High-pressure side (006) (Deltabar) High-pressure side (183) (Deltabar) Options	Determines, which pressure input corresponds to the high-pressure side.  This setting is only valid if the DIP switch "SW/P2 High" is switched off (see "Switch P1/P2 (163) (Deltabar)" parameter). Otherwise P2 corresponds to the high-pressure side in any case. Options: <ul style="list-style-type: none"> P1 High Pressure input P1 is the high-pressure side. P2 High Pressure input P2 is the high-pressure side. Factory setting P1 High
Meas. pressure (020) Display Cerabar M / Deltapilot M	Displays the measured pressure after sensor recalibration, position adjustment and damping.  <pre> graph TD Sensor[Sensor] --> ST[Sensor trim] ST --> PA[Position adjustment] PA --> D[Damping] D --> EDP[Electr. Delta P] EDP --> P[P] P --> Level[Level] Level --> AIB[Analog Input Block] Sensor --> SP[Sensor pressure] PA --> CP[Corrected Press.] D --> SV[Simulation value Pressure] EDP --> PAD[Pressure af. damp] P --> MP[Measuring pressure] P --> Pressure[Pressure] Level --> PV[PV] </pre> <p>PV = Primary Value</p>

Parameter name	Description
Deltabar M	
<pre> graph TD subgraph Transducer_Block [Transducer Block] Sensor[Sensor] --> ST[Sensor trim] ST --> PA[Position adjustment] PA --> Damping[Damping] Damping --> P[P] P --> Pressure[Pressure] P --> Level[Level] P --> Flow[Flow] end Pressure --> SP[Sensor pressure] PA --> CP[Corrected Press.] Damping --> PAD[Pressure af. damp] P --> MP[Measuring pressure] P --> SV[Simulation value Pressure] Pressure --> PV[PV] Level --> PV Flow --> PV PV --> AIB[Analog Input Block] </pre>	
Sensor pressure (109) Display	Displays the measured pressure before the sensor trim and position adjustment.
Corrected press. (172) Display	Displays the measured pressure after the sensor trim and position adjustment.
Pressure af. damp (111) Display	Displays the measured pressure after sensor trim, position adjustment and damping.

Expert → Measurement → Level



Parameter name	Description
Level selection (024) Options	Select the method for calculating the level Options: <ul style="list-style-type: none"> ▪ In pressure If this option is selected, specify two pressure/level value pairs. The level value is displayed directly in the unit that you select via the "Unit before lin (025)" parameter. ▪ In height If this option is selected, specify two height/level value pairs. From the measured pressure, the device first calculates the height using the density. This information is then used to calculate the level in the "Unit before lin (025)" selected using the two value pairs specified. Factory setting: In pressure
Unit before lin (025) Options	Select the unit displayed with the measured value and parameter of the level before linearization.  The unit selected is only used to describe the measured value. This means that the measured value is not converted when a new output unit is selected. Example: <ul style="list-style-type: none"> ▪ Current measured value: 0.3 ft ▪ New output unit: m ▪ New measured value: 0.3 m Options <ul style="list-style-type: none"> ▪ % ▪ mm, cm, dm, m ▪ ft, in ▪ m³, in³ ▪ l, hl ▪ ft³ ▪ gal, lgal ▪ kg, t ▪ lb Factory setting: %
Height unit (026) Options	Select the height unit. The measured pressure is converted to the selected height unit using the " Adjust density (034) " parameter. Prerequisite " Level selection (024) " = In height Options <ul style="list-style-type: none"> ▪ mm ▪ m ▪ in ▪ ft Factory setting: m
Calibration mode (027) Options	Select the calibration mode. Options: <ul style="list-style-type: none"> ▪ Wet Wet calibration takes place by filling and emptying the container. In the case of two different levels, the level, volume, mass or percentage value entered is assigned to the pressure measured at this point in time ("Empty calib. (028)" and "Full calib. (031)" parameters). ▪ Dry Dry calibration is a theoretical calibration. For this calibration, you specify two pressure/level value pairs or height/level value pairs via the following parameters: "Empty calib. (028)", "Empty pressure (029)", "Full calib. (031)", "Full pressure (032)", "Empty height (030)", "Full height (033)". Factory setting: Wet

Parameter name	Description
Empty calib. (028) Empty calib. (011) Entry	Enter the output value for the lower calibration point (container empty). The unit defined in " Unit before lin (025) " will be used.  <ul style="list-style-type: none"> ▪ In the case of wet calibration, the level (container empty) must actually be available. The associated pressure is then automatically recorded by the device. ▪ In the case of dry calibration, the level (container empty) does not have to be available. The associated pressure has to be entered in the "Empty pressure (029)" parameter for the "In pressure" level selection. The associated height has to be entered in the "Empty height (030)" parameter for the "In height" level selection. Factory setting: 0.0
Empty pressure (029) Empty pressure (185) Entry/Display	Enter the pressure value for the lower calibration point (container empty). → See also " Empty calib. (028) ". Prerequisite <ul style="list-style-type: none"> ▪ "Level selection (024)" = In pressure ▪ "Calibration mode (027)" = Dry -> entry ▪ "Calibration mode (027)" = Wet -> display Factory setting: 0.0
Empty height (030) Empty height (186) Entry/Display	Enter the height value for the lower calibration point (container empty). Select the unit via the " Height unit (026) " parameter. Prerequisite: <ul style="list-style-type: none"> ▪ "Level selection (024)" = In height ▪ "Calibration mode (027)" = Dry -> entry ▪ "Calibration mode (027)" = Wet -> display Factory setting: 0.0
Full calib. (031) Full calib. (012) Entry	Enter the output value for the upper calibration point (container full). The unit defined in " Unit before lin (025) " will be used.  <ul style="list-style-type: none"> ▪ In the case of wet calibration, the level (container full) must actually be available. The associated pressure is then automatically recorded by the device. ▪ In the case of dry calibration, the level (container full) does not have to be available. The associated pressure has to be entered in the "Full pressure (032)" parameter for the "In pressure" level selection. The associated height has to be entered in the "Full height (033)" parameter for the "In height" level selection. Factory setting: 100.0
Full pressure (032) Full pressure (187) Entry/Display	Enter the pressure value for the upper calibration point (container full). → See also " Full calib. (031) ". Prerequisite <ul style="list-style-type: none"> ▪ "Level selection (024)" = In pressure ▪ "Calibration mode (027)" = Dry -> entry ▪ "Calibration mode (027)" = Wet -> display Factory setting: Upper-range limit (URL) of the sensor
Full height (033) Full height (188) Entry/Display	Enter the height value for the upper calibration point (container full). Select the unit via the " Height unit (026) " parameter. Prerequisite: <ul style="list-style-type: none"> ▪ "Level selection (024)" = In height ▪ "Calibration mode (027)" = Dry -> entry ▪ "Calibration mode (027)" = Wet -> display Factory setting: Upper-range limit (URL) is converted to a height unit

Parameter name	Description
Density unit (127) Display	Displays the density unit. The measured pressure is converted to a height using the " Height unit (026) " and " Adjust density (034) " parameters. Factory setting: g/cm ³
Adjust density (034) Entry	Enter the density of the medium. The measured pressure is converted to a height using the " Height unit (026) " and " Adjust density (034) " parameters. Factory setting: 1.0
Process density (035) Entry	Enter a new density value for density correction. The calibration was carried out with water as the medium, for example. Now the container is to be used for another medium with another density. The calibration is corrected appropriately by entering the new density value in the " Process density (035) " parameter.  If you change to dry calibration after completing a wet calibration using the " Calibration mode (027) " parameter, the density for the " Adjust density (034) " and " Process density (035) " parameters must be entered correctly before changing the calibration mode. Factory setting: 1.0
Level before lin. (019) Display	Displays the level value before linearization table.

Expert → Measurement → Linearization

Parameter name	Description
Lin. mode (037) Options	Select the linearization mode. Options: <ul style="list-style-type: none"> ▪ Linear The level is output without being converted beforehand. "Level before lin. (019)" is output. ▪ Erase table The existing linearization table is deleted. ▪ Manual entry (sets the table to the edit mode, an alarm is output): The value pairs of the table ("X-value (040) (manual entry)" and "Y-value (041) (manual entry/in semi-auto. entry)") are entered manually. ▪ Semiautomatic entry (sets the table to the edit mode, an alarm is output): The container is emptied or filled in stages in this entry mode. The device records the level value automatically ("X-value (040) (manual entry)"). The associated volume, mass or %-value is entered manually ("Y-value (041) (manual entry/in semi-auto. entry)"). ▪ Activate table The table entered is activated and checked with this option. The device shows the level after linearization. Factory setting: Linear

Parameter name	Description
Unit after lin. (038) Options	Select the unit of the level value after linearization (unit of the Y-value). Options: <ul style="list-style-type: none"> ▪ % ▪ cm, dm, m, mm ▪ hl ▪ in³, ft³, m³ ▪ l ▪ in, ft ▪ kg, t ▪ lb ▪ gal ▪ lgal Factory setting: %
Line numb. (039) Entry	Enter the number of the current point in the table. The subsequent entries in " X-value (040) (manual entry) " and " Y-value (041) (manual entry/in semi-auto. entry) " refer to this point. Input range: 1 to 32
X-value (040) (manual entry) X-value (123) (in linear/activ table) X-value (193) (in semi-auto. entry) Entry/Display	Enter the " X-value (040) (manual entry) " (level before linearization) for the specific point in the table and confirm.  <ul style="list-style-type: none"> ▪ If "Lin. mode (037)" = "Manual entry", the level value must be entered. ▪ If "Lin. mode (037)" = "Semiautomatic entry", the level value is displayed and must be confirmed by entering the associated Y-value.
Y-value (041) (manual entry/in semi-auto. entry) Y-value (194) (in linear/activ table) Entry/Display	Enter the " Y-value (041) (manual entry/in semi-auto. entry) " (value after linearization) for the specific point in the table. The unit is determined by " Unit after lin. (038) ".  The linearization table must be monotonic (increasing or decreasing).
Edit table (042) Options	Select the function for editing the table. Options: <ul style="list-style-type: none"> ▪ Next point: The "Line numb." parameter is incremented by 1. The next point can be entered. ▪ Current point: stay on the current point to correct a mistake for example. ▪ Previous point: The "Line numb." parameter is decremented by 1. The previous point can be corrected/entered again. ▪ Insert point: insert an additional point (see example below). ▪ Delete point: delete the current point (see example below). Example: Add a point - in this case between the 4th and 5th point for example – Select point 5 via the " Line numb. (039) " parameter. – Select the "Insert point" option via the " Edit table (042) " parameter. – Point 5 is displayed for the " Line numb. (039) " parameter. Enter new values for the " X-value (040) (manual entry) " and " Y-value (041) (manual entry/in semi-auto. entry) " parameters. Example: Delete a point - in this case the 5th point for example – Select point 5 via the " Line numb. (039) " parameter. – Select the "Delete point" option via the " Edit table (042) " parameter. – The 5th point is deleted. All of the subsequent points are moved up one number i.e. following deletion, the 6th point becomes Point 5. Factory setting: Current point
Tank description (173) Entry	Enter the tank description (max. 32 alphanumeric characters)
Tank content (043) Display	Displays the level value after linearization.

Expert → Measurement → Flow (Deltabar M)

Parameter name	Description
Flow type (044) Options	Select the flow type. Options: <ul style="list-style-type: none"> ■ Volume operat. cond. (volume under operating conditions) ■ Volume norm. cond. (norm volume under norm conditions in Europe: 1013.25 mbar and 273.15 K (0 °C)) ■ Volume std. cond. (standard volume under standard conditions in the USA: 1013.25 mbar (14.7 psi) and 288.15 K (15 °C/59 °F)) ■ Mass (mass under operating conditions) ■ Flow in % Factory setting: Volume operat. conditions
Mass flow unit (045) Options	Select mass flow unit. When a new flow unit is selected, all flow-specific parameters are converted and displayed with the new unit within a flow type. When the flow type is changed, conversion is not possible. Prerequisite: <ul style="list-style-type: none"> ■ "Flow type" (044) = Mass Options: <ul style="list-style-type: none"> ■ g/s, kg/s, kg/min, kg/h ■ t/s, t/min, t/h, t/d ■ oz/s, oz/min ■ lb/s, lb/min, lb/h ■ ton/s, ton/min, ton/h, ton/d Factory setting: kg/s
Norm. flow unit (046) Options	Select norm flow unit. When a new flow unit is selected, all flow-specific parameters are converted and displayed with the new unit within a flow type. When the flow type is changed, conversion is not possible. Prerequisite: <ul style="list-style-type: none"> ■ "Flow type" (044) = Volume norm. cond. Options: <ul style="list-style-type: none"> ■ Nm³/s, Nm³/min, Nm³/h, Nm³/d Factory setting: Nm ³ /s
Std. flow unit (047) Options	Select standard flow unit. When a new flow unit is selected, all flow-specific parameters are converted and displayed with the new unit within a flow type. When the flow type is changed, conversion is not possible. Prerequisite: <ul style="list-style-type: none"> ■ "Flow type" (044) = Volume std. cond. Options: <ul style="list-style-type: none"> ■ Sm³/s, Sm³/min, Sm³/h, Sm³/d ■ SCFS, SCFM, SCFH, SCFD Factory setting: Sm ³ /s

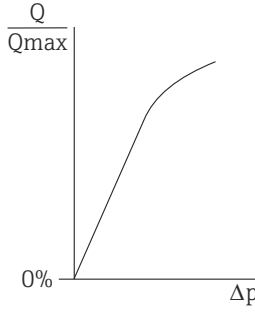
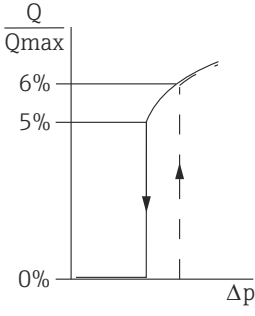
Parameter name	Description
Flow unit (048) Options	Select volume flow unit. When a new flow unit is selected, all flow-specific parameters are converted and displayed with the new unit within a flow type. When the flow type is changed, conversion is not possible. Prerequisite: <ul style="list-style-type: none"> "Flow type" (044) = Volume operat. cond. Options: <ul style="list-style-type: none"> dm³/s, dm³/min, dm³/h m³/s, m³/min, m³/h, m³/d l/s, l/min, l/h hl/s, hl/min, hl/d ft³/s, ft³/min, ft³/h, ft³/d ACFS, ACFM, ACFH, ACFD ozf/s, ozf/min gal/s, gal/min, gal/h, gal/d, Mgal/d Igal/s, Igal/min, Igal/h bbl/s, bbl/min, bbl/h, bbl/d Factory setting: m ³ /s
Max. flow (009) Entry	Enter maximum flow of primary element. See also layout sheet of primary element. The maximum flow is assigned to the maximum pressure which you enter via the "Max. pressure flow" (010) parameter. Factory setting: 100.0
Max. pressure flow (010) Entry	Enter maximum pressure of primary element. → See layout sheet of primary element. This value is assigned to the maximum flow value (→ see "Max. flow (009)"). Factory setting: Upper-range limit (URL) of the sensor
Set low-flow cut-off (049) Entry	Enter switch-on point of the flow-flow cut-off. The hysteresis between the switch-on point and the switch-off point is always 1 % of the maximum flow value. Input range: Switch-off point: 0 to 50 % of end flow value ("Max. flow (009)"). <div style="display: flex; justify-content: space-around;">   </div> Factory setting: 5 % (of the maximum flow value)
Flow (018) Display	Displays the present flow value.

Expert → Measurement → Sensor limits

Parameter name	Description
LRL sensor (101) Display	Displays the lower-range limit of the sensor.
URL sensor (102) Display	Displays the upper-range limit of the sensor.

Expert → Measurement → Sensor trim

Parameter name	Description
Lo trim measured (129) Display	Displays the reference pressure present to be accepted for the lower calibration point.
Hi trim measured (130) Display	Displays the reference pressure present to be accepted for the upper calibration point.
Lo trim sensor (131) Display	Internal service parameter.
Hi trim sensor (132) Display	Internal service parameter.

8.11.3 Communication**Expert → Communication → PROFIBUS PA Info**

Parameter name	Description
Ident number (225) Display	Displays the set identification number.
Profile revision (227) Display	Displays the profile version of the device.

Expert → Communication → PROFIBUS PA conf

Parameter name	Description
Addressing (228) Display	Displays the addressing mode: via hardware (DIP switch) or software. Factory setting: Software
Bus address (233) Display	Displays the set bus address. Factory setting: 126
Ident number sel (229) Options	For entering the identification number of the device. For more information, see Section 6.4.4. Options: <ul style="list-style-type: none"> ▪ Auto ident number: Adaption mode of the device ▪ Profile: 0x9700 ▪ Manufacturer-specific: 0x1553 (Cerabar), 0x1554 (Deltabar), 0x1555 (Deltapilot) ▪ Compatibility mode: 0x151C (Cerabar), 0x1503 (Deltapilot) "Auto ident number" Factory setting: Auto ident number
Cond.status diag (234) Display/Options	Displays whether "Condensed status" or "Classic status" is set. Further informations see → Chap. 6.4.4. Factory setting: Condensed status

Expert → Communication → Analog input 1

Parameter name	Description
Channel (171) Display	Displays the Transducer Block measured variable that is used. Factory setting: Primary value

Parameter name	Description
Output value (Out Value) (224) Display	Displays the output value (Out Value) of the Analog Input 1 Block.
Status (196) Display	Displays the output status (Out Status) of the Analog Input 1 Block.
Filt. time const. (197) Entry	For entering the damping time of the Analog Input 1 Block. Factory setting: 0.0 sec.
Fail safe mode (198) Options	Specifies the output value of the Analog Input 1 in case of an error. Options: <ul style="list-style-type: none"> ▪ Fail safe value ▪ Last valid out val. ▪ Status BAD Factory setting: Last valid out val.
Failsafe default (199) Entry	Substitute value in case of an error. Prerequisite: <ul style="list-style-type: none"> ▪ "Fail safe mode (198)" = Fail safe value Factory setting: 0.0

Expert → Communication → Analog input 2

Parameter name	Description
Channel (230) (Cerabar/Deltapilot) Channel (231) (Deltabar) Options	Select the Transducer Block measured variable to be used. Options: <ul style="list-style-type: none"> ▪ Totalizer 2 (Deltabar) ▪ Level before lin. (019) ▪ Pressure ▪ Temperature (Cerabar/Deltapilot) Factory setting: Pressure
Output value (Out Value) (201) Display	Output value (Out Value) of the Analog Input 2 Block.
Status (202) Display	Output status (Out Status) of the Analog Input 2 Block.
Filt. time const. (203) Entry	For entering the damping time of the Analog Input 2 Block. Factory setting: 0.0 sec.
Fail safe mode (204) Options	Specifies the output value of the Analog Input 2 in case of an error. Options: <ul style="list-style-type: none"> ▪ Fail safe value ▪ Last valid out val. ▪ Status BAD Factory setting: Last valid out val.
Failsafe default (205) Entry	Substitute value in the event of an error. Prerequisite: <ul style="list-style-type: none"> ▪ "Fail safe mode (204)" = Fail safe value Factory setting: 0.0

Expert → Communication → Analog output 1

Parameter name	Description
Fail safe time (206) Options	For entering the damping time of the Analog output 1 Block. Factory setting: 0.0 sec.
Fail safe mode (207) Options	Specifies the output value of the Analog output 1 in case of an error. Options: <ul style="list-style-type: none"> ▪ Fail safe value ▪ Last valid out val. ▪ Status BAD Factory setting: Last valid out val.
Failsafe default (208) Entry	Substitute value in the event of an error. Prerequisite: <ul style="list-style-type: none"> ▪ "Fail safe mode (207)" = Fail safe value Factory setting: 0.0
Input value (209) Display	Displays the value that is sent to the device.
Input status (220) Display	Displays the status that is sent to the device.
Unit (211) Options	For entering the unit for the value that is sent to the device. Options: <ul style="list-style-type: none"> ▪ % ▪ Pressure units ▪ Flow units ▪ Level units ▪ Temperature units ▪ Unknown Factory setting: Unknown

Expert → Communication → Analog output 2

Parameter name	Description
Fail safe time (212) Options	Enter the damping time of the Analog output 1 Block. Factory setting: 0.0 sec.
Fail safe mode (213) Options	Specifies the output value of the Analog output 1 in the event of an error. Options: <ul style="list-style-type: none"> ▪ Fail safe value ▪ Last valid out val. ▪ Status BAD Factory setting: Last valid out val.
Failsafe default (214) Entry	Substitute value in the event of an error. Prerequisite: <ul style="list-style-type: none"> ▪ "Fail safe mode (213)" = Fail safe value Factory setting: 0.0
Input value (215) Display	Displays the value that is sent to the device.
Input status (223) Display	Displays the status that is sent to the device.

Parameter name	Description
Unit (217) Options	For entering the unit for the value that is sent to the device. Options: <ul style="list-style-type: none"> ■ Pressure units, temperature units

Expert → Communication → Totalizer 1 (Deltabar)



With the "Flow in %" flow type setting, the totalizer is not available and is not displayed at this position.

Parameter name	Description
Channel (218) Display	Displays the measured variable that is used as input value for the channel. Factory setting: Flow
Eng.unit total.1 (058) (059) (060) (061) Options	Select unit for totalizer 1. Options Depending on the setting in the " Flow type (044) " parameter (→ 138), this parameter offers a list of volume, norm volume, standard volume and mass units. When a new volume or mass unit is selected, totalizer-specific parameters are converted and displayed with the new unit within a unit group. When the flow mode is change, the totalizer value is not converted. The Direct Access Code depends on the selected " Flow type (044) ": <ul style="list-style-type: none"> - (058): Flow. meas. type "Mass" - (059): Flow. meas. type "Volume norm. cond." - (060): Flow. meas. type "Volume std. cond." - (061): Flow. meas. type "Volume process cond." Factory setting: m ³ (Flow. meas. type "Volume process cond.")
Totalizer 1 mode (175) Options	Define the behavior of the totalizer. Options: <ul style="list-style-type: none"> ■ Balanced: Integration of all measured flows (positive and negative) ■ Pos. flow only: only positive flows are integrated. ■ Neg. flow only: only negative flows are integrated. ■ Hold: The totalizer is stopped and keeps its current value. Factory setting: Pos. flow only
Total. 1 failsafe (221) Options	Set the failsafe mode of the totalizer. Options: <ul style="list-style-type: none"> ■ Actual value (It is integrated with the current flow value on.) ■ Hold (stop the totalizer) ■ Memory (the totalizer continues running with the last valid value) Factory setting: Actual value
Total.1 value (219) Options	Set the totalizer to zero or a predefined value. Options: <ul style="list-style-type: none"> ■ Totalize (normal function of the totalizer) ■ Reset (totalizer is reset to zero) ■ Preset (totalizer is set to a predefined value (see "Preset value (222)".)) Factory setting: Totalize
Preset value (222) Entry	Value for setting the totalizer to a predefined value, see option "Preset" of " Total.1 value (219) ". Factory setting: 0.0

Parameter name	Description
Totalizer 1 (261) Display	Displays the totalizer value.
Status (236) Display	Displays the totalizer status.

8.11.4 Application

Expert → Application (Cerabar M and Deltapilot M)

Parameter name	Description
Electr. Delta P (158) (Cerabar / Deltapilot) Options	This function activates the electr. delta P application with an external or constant value. Options: <ul style="list-style-type: none"> ■ Off ■ Ext. value2 ■ Constant Factory setting: Off
Fixed ext. value (174) (Cerabar / Deltapilot) Entry	Use this function to enter the constant value for the electr. delta P application. The value refers to " Press. eng. unit (125) " Factory setting: 0.0
Ext. val. 2 (259) Display	Displays the PROFIBUS input value 2 (Analog Output 2).
Ext. val. 2 status (260) Display	Displays the status of the PROFIBUS input value 2 (Analog Output 2).

Expert → Application → Totalizer 2 (Deltabar M)



With the "Flow in %" flow type setting, the totalizer is not available and is not displayed at this position.

Parameter name	Description
Eng. unit totalizer 2 (065) (066) (067) (068) Options	Select the unit for totalizer 2. The Direct Access Code depends on the selected " Flow type (044) ": <ul style="list-style-type: none"> - (065): Flow. meas. type "Mass" - (066): Flow. meas. type "Gas norm. cond." - (067): Flow. meas. type "Gas. std. cond." - (068): Flow. meas. type "Volume process cond." Factory setting: m ³
Totalizer 2 mode (177) Options	Define the behavior of the totalizer 2. Options: <ul style="list-style-type: none"> ■ Balanced: Integration of all measured flows (positive and negative) ■ Pos. flow only: only positive flows are integrated. ■ Neg. flow only: only negative flows are integrated. ■ Hold: The totalizer is stopped and keeps its current value. Factory setting: Pos. flow only

Parameter name	Description
Total. 2 failsafe (178) Options	Define the behavior of the totalizer in the case of an error. Options: <ul style="list-style-type: none"> ▪ Actual value (It is integrated with the current flow value on.) ▪ Hold: The totalizer is stopped and keeps its current value. Factory setting: Actual value
Totalizer 2 (069) Display	Displays the totalizer value. The Totalizer 2 overflow (070) parameter displays the overflow. Example: The value 123456789 m ³ is indicated as follows: <ul style="list-style-type: none"> - Totalizer 1: 3456789 m³ - Totalizer 1 overflow: 12 E7 m³
Totalizer 2 overflow (070) Display	Displays the overflow value of totalizer 2. → See also " Totalizer 2 (069) ".

8.11.5 Diagnosis

Expert → Diagnosis

Parameter name	Description
Diagnostic code (071) Display	Displays the diagnostic message with the highest priority currently present.
Last diag. code (072) Display	Displays the last diagnostic message that occurred and was rectified.  The messages listed in the Last diag. code (072) parameter can be deleted via the " Reset logbook (159) " parameter.
Reset logbook (159) Options	With this parameter, you reset all the messages of the " Last diag. code (072) " parameter and the "Last diag. 1 (085)" to "Last diag. 10 (094)" event log. Options: <ul style="list-style-type: none"> ▪ Abort ▪ Confirm Factory setting: Abort
Min. meas. press. (073) Display	Displays the lowest pressure value measured (peakhold indicator). You can reset this indicator by means of the " Reset peakhold (161) " parameter.
Max. meas. press. (074) Display	Displays the highest pressure value measured (peakhold indicator). You can reset this indicator by means of the " Reset peakhold (161) " parameter.
Reset peakhold (161) Options	You can reset the "Min. meas. press." and "Max. meas. press." indicators with this parameter. Options: <ul style="list-style-type: none"> ▪ Abort ▪ Confirm Factory setting: Abort
Alarm behav. P (050) Options	Set the measured value status for when the sensor limits are exceeded or undershot. Options: <ul style="list-style-type: none"> ▪ Warning The device continues measuring. An error message is displayed. "UNCERTAIN" is displayed for the measured value status. ▪ Alarm "BAD" is displayed for the measured value status. An error message is displayed. Factory setting: Warning

Parameter name	Description
Operating hours (162) Display	Displays the operating hours of the device. This parameter cannot be reset.
Config. counter (100) Display	Displays the configuration counter. This counter is increased by one every time a parameter or group is changed. The counter counts up to 65535 and then starts again at zero.

Expert → Diagnosis → Diagnostic list

Parameter name	Description
Diagnostic 1 (075) Diagnostic 2 (076) Diagnostic 3 (077) Diagnostic 4 (078) Diagnostic 5 (079) Diagnostic 6 (080) Diagnostic 7 (081) Diagnostic 8 (082) Diagnostic 9 (083) Diagnostic 10 (084)	These parameters contain up to ten diagnosis messages that are currently pending, arranged in order of priority.

Expert → Diagnosis → Event logbook

Parameter name	Description
Last diag. 1 (085) Last diag. 2 (086) Last diag. 3 (087) Last diag. 4 (088) Last diag. 5 (089) Last diag. 6 (090) Last diag. 7 (091) Last diag. 8 (092) Last diag. 9 (093) Last diag. 10 (094)	These parameters contain the last occurred 10 diagnosis messages that have been rectified. They can be reset using the "Reset logbook (159)" parameter. Errors which have occurred multiple times are displayed once only.

Expert → Diagnosis → Simulation

Parameter name	Description
Simulation mode (112) Options	<p>Switch on the simulation mode and select the simulation type. Any simulation running is switched off if the measuring mode or Lin. mode (037) level mode is changed.</p> <p>Options:</p> <ul style="list-style-type: none"> ▪ None ▪ Pressure, → see this table, "Sim. pressure (113)" parameter ▪ Level, → see this table, "Sim. level (115)" parameter ▪ Flow, → see this table, "Sim. flow (114) (Deltabar)" parameter ▪ Tank content, → see this table, "Sim. tank cont. (116)" parameter ▪ Alarm/warning, → see this table, "Sim. error no. (118)" parameter
Cerabar M / Deltapilot M	<div style="border: 1px solid black; padding: 10px; margin: 10px 0;"> <div style="display: flex; align-items: center;"> <div style="border-right: 1px solid black; padding-right: 10px; width: 150px;">Transducer Block</div> <div style="text-align: center; flex-grow: 1;"> <div style="border: 1px solid black; padding: 5px; margin-bottom: 5px;">Sensor</div> <div style="text-align: center;">↓</div> <div style="border: 1px solid black; padding: 5px; margin-bottom: 5px;">Sensor trim</div> <div style="text-align: center;">↓</div> <div style="border: 1px solid black; padding: 5px;">Position adjustment</div> </div> </div> </div>

Parameter name	Description
	<div style="text-align: center;"> ↓ ← Simulation value Pressure ↓ Damping ↓ Electr. Delta P ↓ P ↓ Pressure ← Level ↓ → PV PV = Primary Value ↓ Analog Input Block </div>
	<div style="text-align: center;"> ↓ ← Simulation value: - Level - Tank content ↓ ↓ ↓ → PV PV = Primary Value ↓ Analog Input Block </div>
Sim. pressure (113) Entry	<p>Enter the simulation value. → See also "Simulation mode (112)".</p> <p>Prerequisite:</p> <ul style="list-style-type: none"> ▪ "Simulation mode (112)" = Pressure <p>Value when switched on: Current pressure measured value</p>
Sim. flow (114) (Deltabar) Entry	<p>Enter the simulation value. → See also "Simulation mode (112)".</p> <p>Prerequisite:</p> <ul style="list-style-type: none"> ▪ "Measuring mode (005)" = Flow and "Simulation mode (112)" = Flow

Parameter name	Description
Sim. level (115) Entry	Enter the simulation value. → See also " Simulation mode (112) ". Prerequisite: ▪ " Measuring mode (005) " = Level and " Simulation mode (112) " = Level
Sim. tank cont. (116) Entry	Enter the simulation value. → See also " Simulation mode (112) ". Prerequisites: ▪ " Measuring mode (005) " = Level, Lin. mode (037) = "Activate table" and " Simulation mode (112) " = Tank content.
Sim. error no. (118) Entry	Enter the diagnostic message number. → See also " Simulation mode (112) ". Prerequisite: ▪ " Simulation mode (112) " = Alarm/warning Value when switched on: 484 (Simulation mode (112) active)

8.12 Saving or duplicating device data

The device does not have a memory module. With an operating tool based on FDT technology (e.g. FieldCare), the following options are, however, available (see "Download select." parameter → 129 in the operating menu or via the Physical Block → 165.):

- Storage/recovery of configuration data
- Duplication of device parameters
- Transfer of all relevant parameters when replacing electronic inserts.

For further information, please refer to the Operating Instructions for the FieldCare operating program.

9 Commissioning via Class 2 master (FieldCare)

The device is configured at the factory for the Pressure measuring mode (Cerabar, Deltabar) or Level measuring mode (Deltapilot). The measuring range and the unit in which the measured value is transmitted correspond to the specifications on the nameplate.

▲ WARNING

Exceeding the maximum allowable working pressure!

Risk of injury due to bursting of parts! Warning messages are generated if pressure is too high.

- ▶ If a pressure smaller than the minimum permitted pressure or greater than the maximum permitted pressure is present at the device, the following messages are output in succession (depending on the setting in the "Alarm behavior" (050) parameter):
"S140 Working range P" or "F140 Working range P"
"S841 Sensor range" or "F841 Sensor range"
"S971 Adjustment"
Use the device only within the sensor range limits.

NOTICE



Shortfall of the allowable working pressure!

Output of messages if pressure is too low.

- ▶ If a pressure smaller than the minimum permitted pressure or greater than the maximum permitted pressure is present at the device, the following messages are output in succession (depending on the setting in the "Alarm behavior" (050) parameter):
"S140 Working range P" or "F140 Working range P"
"S841 Sensor range" or "F841 Sensor range"
"S971 Adjustment"
Use the device only within the sensor range limits.

9.1 Function check

Carry out a post-installation and a post-connection check as per the checklist before commissioning the device.

- "Post-installation check" checklist →  38
- "Post-connection check" checklist →  44

9.2 Commissioning

The procedure for commissioning and operating the FieldCare program is described in the integrated FieldCare online help.

Proceed as follows to commission the device:

1. Check the hardware write protection on the electronic insert (→ [§ 54](#), Section 6.3.5 "Locking/unlocking operation").
The "**Lock switch (120)**" parameter indicates the status of the hardware write protection (Menu path: Expert → System or Expert → Communication → Physical Block → PB Parameter → Device)
2. Enter the tag name via the "TAG" parameter. (Menu path: Expert → System → Instrument info or Setup → Extended Setup → Instrument Info)
3. Assign the device an address in the bus:
Operating program of the DP Class 2 master such as FieldCare: (→ [§ 60](#), Section 6.4.5 "Device identification and addressing" or via the address switch.
4. Configure the manufacturer-specific device parameters via the Setup menu or configure the Transducer Block
Configure the Analog Output Block
Configure the Totalizer Block (Deltabar).
5. Configure the Physical Block (menu path: Expert → Communication → Physical Block)
6. Configure the Analog Input Block or AI-Block.
 - In the Analog Input Block, the input value or input range can be scaled in accordance with the requirements of the automation system (→ [§ 151](#), Section 9.3.1 "Scaling the output value (Out Value)").
 - Set limit values if necessary.
7. Configure cyclic data transmission (→ [§ 62](#), Section 6.4.6 "System integration" and → [§ 65](#), Section 6.4.7 "Cyclic data exchange").

9.3 Output value (Out Value)

9.3.1 Scaling the output value (Out Value)

In the Analog Input Block, the input value or input range can be scaled in accordance with the automation requirements.

Example:

The measuring range 0 to 500 mbar should be rescaled to 0 to 10000.

- Select the "Proc value scale" group.
 Menu path: Expert → Communication → Analog input 1 → AI parameter → Proc value scale
 - Enter "0" as the lower value.
 - Enter "500" as the upper value.
- Select the "Output scale" group.
 Menu path: Expert → Communication → Analog input 1 → AI parameter → Output scale
 - For EU_0_PERCENT (lower value), enter "0".
 - For EU_100_PERCENT (upper value), enter "10000".
 - For UNITS_INDEX (unit), select "User unit" for example.
 The unit selected here does not have any effect on the scaling.
- Result:
 At a pressure of 350 mbar, the value 7000 is output to the PLC as the output value (OUT Value).

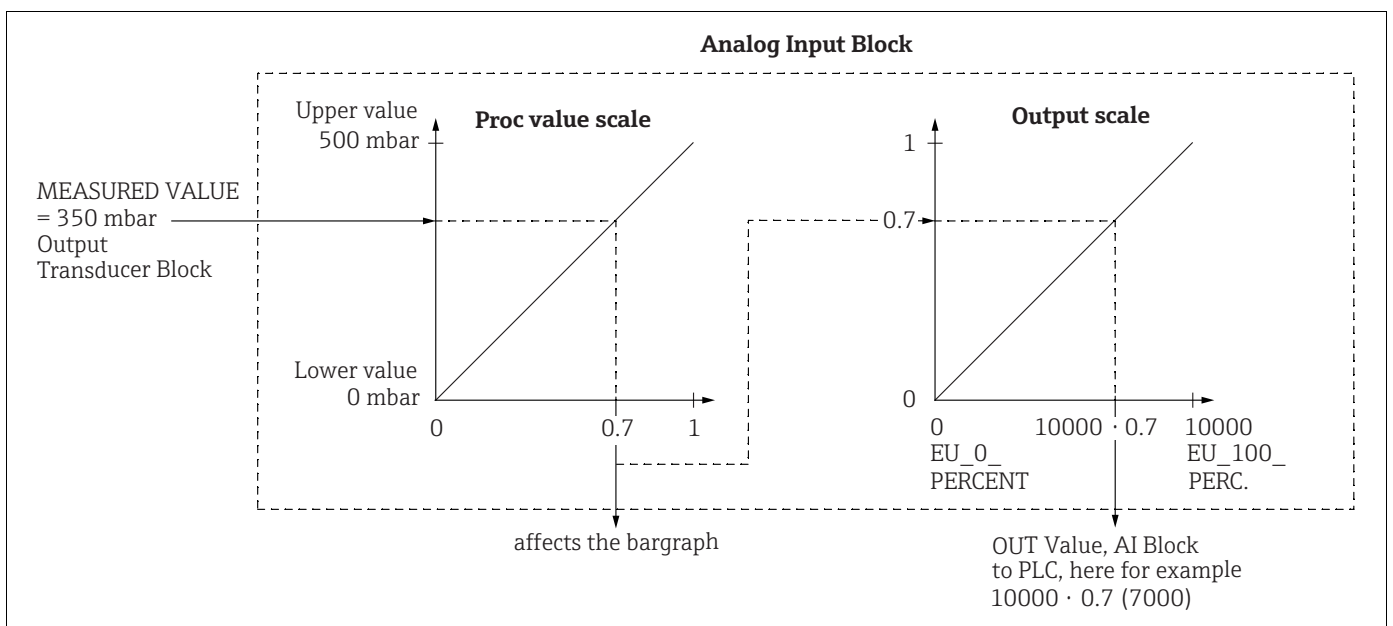

⚠ CAUTION

Note Dependencies when setting parameters!

- ▶ The output value (Out Value) can only be scaled via remote operation (e.g. FieldCare).
- ▶ When a unit changes within a measuring mode (pressure, flow - flow type), the values for "Proc value scale" and "Output scale" are converted.
 When a unit changes within a measuring mode, the "Proc value scale" is converted and "Output scale" is updated.
- ▶ If the measuring mode is changed, no conversion takes place. The device has to be recalibrated if the measuring mode is changed.

- ▶ 2 AIs are available. The first is assigned to the primary value and the second can be assigned to a second measured variable. Both must be scaled accordingly.
- ▶ When the configuration (measuring mode, unit, scaling) is changed in the Transducer Block, the values of "Proc value scale" and "Output scale" are automatically set equal to the Transducer Block scaling.
- ▶ The unit of "Proc value scale" is the primary value unit of the Transducer Block.
- ▶ The configuration of the AI Block 1 is automatically updated with the Transducer Block configuration (if the configuration of the Transducer Block is changed in the Setup menu, this change is copied to the AI Block). This means that the configuration of the AI Blocks must be performed at the end, as the configuration would be overwritten by the setup otherwise.

9.4 Electrical differential pressure measurement with gauge pressure sensors (Cerabar M or Deltapilot M)

Example:

In the example given, two Cerabar M or Deltapilot M devices (each with a gauge pressure sensor) are interconnected. The pressure difference can thus be measured using two independent Cerabar M or Deltapilot M devices.



For a description of the parameters mentioned → Chap. 8.11 "Description of parameters".

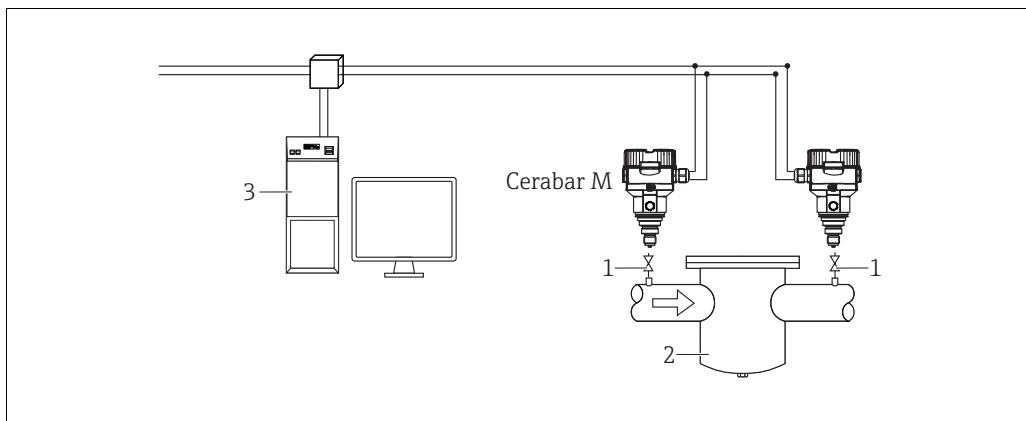

Fig. 41:
 1 Shut-off valves
 2 E.g. filter
 3 PA HOST System

1.)

Description Adjustment of the Cerabar M/Deltapilot M on the high-pressure side in the Transducer Block	
1	Open the Transducer Block.
2	Select the "Pressure" measuring mode via the "Measuring mode (005)" or "Transmitter type" parameter.
3	Select a pressure unit via the "Press. eng. unit" parameter (125), here "mbar" for example.
4	The Cerabar M/Deltapilot M is unpressurized, perform position adjustment, see → 86.
5	Set the Transducer Block to the "Auto" block mode. Where necessary, configure via the Analog Input Block "Channel" parameter and output scaling (→ 168).

2.)

The output of the Analog Input Block of the device on the high-pressure is read by the PLC and sent as an output variable via the input of the Analog Output 2 block of the device on the low-pressure side. Here, the "Unit" of Analog Output 2 must be set to a pressure unit (the same unit as the unit of the device on the high-pressure side).

3.)

Description Adjustment of the Cerabar M/Deltapilot M on the low-pressure side (the differential is generated in this device) in the Transducer Block	
1	Select the "Pressure" measuring mode via the " Measuring mode (005) " or "Transmitter type" parameter.
2	Select a pressure unit via the " Press. eng. unit (125) " parameter, here "mbar" for example.
3	The Cerabar M/Deltapilot M is unpressurized, perform position adjustment, see → 86.
4	Select "Ext. value 2" via the " Electr. Delta P (158) (Cerabar / Deltapilot) " parameter.
5	Select the desired pressure unit via the "Unit" parameter in the Analog Output 2 Block (here "mbar" for example).
6	The current measured values and status information returned by the device on the high-pressure side can be read via the "Ext. value 2" and "Ext. val. 2 status" parameters.

⚠ CAUTION**Note Dependencies when setting parameters!**

- ▶ It is not permitted to reverse the assignment of the measuring points and the direction of communication.
- ▶ The measured value of the transmitting device must always be greater than the measured value of the receiving device (via the "Electr. delta P" function).
- ▶ Adjustments that result in an offset of the pressure values (e.g. position adjustment, trim) must always be performed in accordance with the individual sensor and its orientation, independently of the "Electr. Delta P" application. Other settings result in non-permitted use of the "Electr. Delta P" function and can lead to incorrect measured values.
- ▶ In order to be able to transmit the "BAD" status of the transmitting device (high-pressure side) to the receiver device (low-pressure side), the "**Fail safe mode (198)**" parameter of the analog input of the device on the high-pressure side and the "**Fail safe mode (213)**" parameter of analog output 2 of the device on the low-pressure side must be set to "Status BAD".

9.5 Description of parameters

9.5.1 Block model

The Cerabar M/Deltabar M/Deltapilot M has the following blocks:



- Physical Block
- Analog Input Block 1 / Analog Input Block 2
- Analog Output Block 1 / Analog Output Block 2
- Totalizer Block (Deltabar M)
- Transducer Block

9.5.2 Physical Block



Expert → Communication → Physical Block → PB Standard Parameter	
Parameter name	Description
Block object Display Slot: 0 Index: 16	<p>The "Block object" parameter is a structured parameter consisting of 13 elements. This parameter describes the characteristics of the Physical Block.</p> <p>Reserved profile parameter</p> <ul style="list-style-type: none"> ■ 250 = not used <p>Block object</p> <ul style="list-style-type: none"> ■ 1 = Physical Block <p>Parent class</p> <ul style="list-style-type: none"> ■ 1 = Transmitter <p>Class</p> <ul style="list-style-type: none"> ■ 250 = not used <p>Device rev.</p> <ul style="list-style-type: none"> ■ 1 <p>Device rev. comp</p> <ul style="list-style-type: none"> ■ 1 <p>DD_revision</p> <ul style="list-style-type: none"> ■ 0 (for future use) <p>Profile</p> <ul style="list-style-type: none"> ■ Number of the PROFIBUS PA profile in the PNO ■ 0x40, 0x02 (compact class B) <p>Profile revision</p> <ul style="list-style-type: none"> ■ Displays the profile version, here: 0x302 (Profile 3.02) <p>Execution time</p> <ul style="list-style-type: none"> ■ 0 (for future use) <p>No. of parameters</p> <ul style="list-style-type: none"> ■ Number of parameters of the Physical Block, here: 110 <p>Index of View 1 Fb</p> <ul style="list-style-type: none"> ■ Address of the "PB view 1" parameter, here: 0x00, 0x7E <p>Number of view lists</p> <ul style="list-style-type: none"> ■ 1 = The Block contains one "View object".
Static rev. no. Display Index: 0 Slot: 17	<p>Displays the static revision counter for the parameters of the Physical Block. The counter is incremented by one with each change of a static parameter of the Physical Block. The counter counts up to 65535 and then starts again at zero.</p> <p>Factory setting: 0</p>
TAG Entry Slot: 0 Index: 18	<p>Enter device tag e.g. TAG number (max. 32 alphanumeric characters).</p> <p>Factory setting: ----- or as per order specifications</p>

Expert → Communication → Physical Block → PB Standard Parameter	
Parameter name	Description
Strategy Entry Slot: 0 Index: 19	Enter user-specific value for grouping and thus faster evaluation of the blocks. Grouping takes place by entering the same numerical value for the "Strategy" parameter of the block in question. Input range: 0 to 65535 Factory setting: 0
Alert key Entry Slot: 0 Index: 20	Enter the user-specific value (e.g. identification number of the plant unit). The process control system can use this information to sort alarms and events that were generated by this block. Input range: 0 to 255 Factory setting: 0
Target mode Options Slot: 0 Index: 21	Select the desired block mode. Only the "Automatic (Auto)" mode can be selected for the Physical Block. Options: ▪ Automatic (Auto) Factory setting: Automatic (Auto)
Block mode Display Slot: 0 Index: 22	The "Block mode" parameter is a structured parameter consisting of three elements. PROFIBUS makes a distinction between the following block modes: automatic mode (Auto), manual user intervention (Man) and out of service (O/S). The Physical Block only works in the automatic mode (Auto) and out of service (O/S). Actual mode ▪ Displays the current block mode. ▪ Factory setting: automatic (Auto) Permitted mode ▪ Displays the modes supported by the block. ▪ Factory setting: 8 = automatic (Auto) Normal mode ▪ Displays the normal working mode of the block. ▪ Factory setting: automatic (Auto)
Alarm summary Display Slot: 0 Index: 23	The "Alarm summary" is a structured parameter consisting of four elements. Current alarm summary ▪ Displays the current alarms ▪ Factory setting: 0x0, 0x0
Firmware version Display Slot: 0 Index: 24	Displays the software version. E.g.: 01.00.10
Hardware Rev. Display Slot: 0 Index: 25	Displays the revision number of the main electronics. E.g. 01.00.00
Manufacturer ID Display Slot: 0 Index: 26	Displays the manufacturer number in decimal numerical format. Here: 17 Endress+Hauser

Expert → Communication → Physical Block → PB Standard Parameter	
Parameter name	Description
Device name str. Display Slot: 0 Index: 27	Displays the name of the device. Possible names: Cerabar M, Deltabar M or Deltapilot M
Serial number Display Slot: 0 Index: 28	Displays the serial number of the device (11 alphanumeric characters).
Diagnosis Display Slot: 0 Index: 29	The "Diagnosis" parameter is a structured parameter consisting of two elements. This parameter displays bit-encoded profile alarms that are pending. Several alarm messages can occur at any one time. If the highest bit of the fourth byte is set to 1, see the "Diag extension" (→ see this table) and "Advanced diagnostics 7 (Diag add ext.)" (→ ¶ 163) parameters display additional messages. Diagnose ■ Factory setting: 0x0, 0x0, 0x0, 0x0
Diag extension Display Slot: 0 Index: 30	The "Diag extension" parameter is a structured parameter consisting of three elements. This parameter displays bit-encoded manufacturer-specific alarms and warnings that are pending. Several alarm messages can occur at any one time. In addition, the "Advanced diagnostics 7 (Diag add ext.)" parameter (→ ¶ 163) can display additional alarm messages and warnings. Extended diagnostics 1, 2 ■ Factory setting: 0x0, 0x0 Extended diagnostics 3, 4 ■ Factory setting: 0x0, 0x0 Extended diagnostics 5, 6 ■ Factory setting: 0x0, 0x0
Diag mask Display Slot: 0 Index: 31	The "Diag mask" parameter is a structured parameter consisting of two elements. This parameter describes what profile alarms are supported by the device. Bit = 0: alarm is not supported; Bit = 1: alarm is supported. Diag mask A ■ 0xB1, 0x24 Diag mask B ■ 0x0, 0x80
Diag mask Ex Display Slot: 0 Index: 32	This parameter describes what manufacturer-specific alarms and warnings are supported by the device. Bit = 0: alarm is not supported; Bit = 1: alarm is supported.
Dev. certificat. Display Slot: 0 Index: 33	Displays the certificate.

Expert → Communication → Physical Block → PB Standard Parameter	
Parameter name	Description
Write locking Entry Slot: 0 Index: 34	Use this function to enter a code to lock or unlock operation.  <ul style="list-style-type: none"> ▪ The -symbol on the onsite display indicates that operation is locked. Parameters which refer to how the display appears, e.g. "Language (000)", can still be modified. ▪ If operation is locked by means of the DIP switch, you can only unlock operation again by means of the DIP switch. If operation is locked by means of remote operation e.g. FieldCare, you can only unlock operation again by means of remote operation. <p>Options:</p> <ul style="list-style-type: none"> ▪ Lock: Enter the number 0. ▪ Unlock: Enter the number 2457. <p>Factory setting: 2457</p>
Enter reset code Entry Slot: 0 Index: 35	Reset parameters completely or partially to the factory values or order configuration using the "Enter reset code". Factory setting: 0
Additional info. Entry Slot: 0 Index: 36	Enter the tag description (max. 32 alphanumeric characters). Factory setting: Empty field or as per order specifications
Message Entry Slot: 0 Index: 37	Enter the user-specific "Message", e.g. a description of the device in the application or plant (max. 32 alphanumeric characters). Factory setting: ----- or as per order specifications
Install. date Entry Slot: 0 Index: 38	Enter the installation date of the device (max. 16 alphanumeric characters). Factory setting: Empty field
Ident number sel Options Slot: 0 Index: 40	Select the device master data (GSD file) Cerabar M: <ul style="list-style-type: none"> ▪ 0x9700: Profile GSD ▪ 0x1553: Device-specific GSD (factory setting) ▪ 0x151C: Device-specific GSD. The device behaves like a Cerabar M PMC41, PMC45, PMP41, PMP45, PMP46, PMP48. → See Operating Instructions BA00222P. <p>Deltabar M:</p> <ul style="list-style-type: none"> ▪ 0x9700: Profile GSD ▪ 0x1554: Device-specific GSD (factory setting) <p>Deltapilot M:</p> <ul style="list-style-type: none"> ▪ 0x9700: Profile GSD ▪ 0x1555: Device-specific GSD (factory setting) ▪ 0x1503: Device-specific GSD. The device behaves like a Deltapilot S DB50, DB50L, DB51, DB52 or DB53. → See Operating Instructions BA00164F.
Lock switch Display Slot: 0 Index: 41	Displays the status of DIP switch 1 (on) on the electronic insert. You can lock or unlock parameters relevant to the measured value with DIP switch 1. If operation is locked by means of the "Write locking" parameter, you can only unlock operation again by means of this parameter ("Write locking" →  158). Display: <ul style="list-style-type: none"> ▪ On (locking switched on) ▪ Off (locking switched off) <p>Factory setting: Off (locking switched off)</p>

Expert → Communication → Physical Block → PB Standard Parameter	
Parameter name	Description
Feature Display Slot: 0 Index: 42	Displays optional features implemented in the device, and the status of these features. It indicates whether the feature is supported or not. The settings are based on the actual identification number of the device. The "Classic" and "Condensed" status modes are supported in the profile Ident_Number and both are set in the feature. Only the "Classic" status are supported in the compatibility mode (old identification number). Only the "Condensed" status is supported with the new identification number.
Cond.status diag Display Slot: 0 Index: 43	Indicates the mode of a device that can be configured for status and diagnostic behavior. Options: <ul style="list-style-type: none"> ▪ Condensed status ▪ Classic status Factory setting: Condensed status

Expert → Kommunikation → Physical Block → PB Endress+Hauser Parameter	
Parameter name	Description
Diagnostic code Display Slot: 0 Index: 54	Displays the current message present. → See also these Operating Instructions, Section 11.1 "Messages". The "Status (Device Status)" field and the "Diagnostic code" display the message with the highest priority.
Last diag. code Slot: 0 Index: 55	Displays the last message that occurred and have been already fixed.  <ul style="list-style-type: none"> ▪ The messages listed in the Last diag. code parameter can be deleted via the "Reset logbook" parameter.
Bus address Display Slot: 0 Index: 59	Displays the device address in the PROFIBUS PA bus. You can configure the address either locally on the electronic insert (hardware addressing) or via the software (software addressing). Using a DIP switch on the electronic insert, you can specify whether the hardware or software address is active. Factory setting: 126
Set unit to bus Options Slot: 0 Index: 61	The onsite display and the "Primary value" parameter display the same value as standard. The digital output value (Out Value) of the Analog Input Block "Output value (Out Value)" is independent of the onsite display and the "Primary value". The following options are available to make the onsite display, the "Primary value" and the digital output value (Out Value) display the same value. <ul style="list-style-type: none"> ▪ Set the values for the lower and upper limit of the "Proc value scale" (→ 168) and "Output scale" (→ 168) as equal in the Analog Input Block ▪ Via the "Set unit to bus" parameter, confirm the "On" option. Confirming the option automatically sets the limits for "Proc value scale" and "Output scale" to equal values.  <p>If you confirm the "Set unit to bus" parameter, please note that a change in the digital output value (Out Value) can affect the control system.</p>

Expert → Kommunikation → Physical Block → PB Endress+Hauser Parameter	
Parameter name	Description
Ext. value 1 Display Slot: 0 Index: 62	<p>The "Ext. value 1" parameter is a structured parameter consisting of three elements. The value and status displayed here is transmitted to the device via Analog Output Block 1 by the PLC. The "Ext. value 1" can be displayed on the onsite display (see → Fig. 31 and the "Display mode" parameter).</p> <p>Ext. val. 1</p> <ul style="list-style-type: none"> ▪ Factory setting: 0.0 <p>Ext. val. 1 status</p> <ul style="list-style-type: none"> ▪ Factory setting: BAD <p>Ext. val. 1 avail.</p> <ul style="list-style-type: none"> ▪ This element indicates whether the PLC is sending a value to the device. <ul style="list-style-type: none"> 0: The PLC is not sending a value, along with the status, to the device. 1: The PLC is sending a value, along with the status, to the device. ▪ Factory setting: 0
Profile revision Display Slot: 0 Index: 64	Displays the profile version, here: 3.02.
Reset logbook Options Slot: 0 Index: 65	<p>Use this parameter to reset all the messages of the "Last diag. code" parameter.</p> <p>Options:</p> <ul style="list-style-type: none"> ▪ Abort ▪ Confirm <p>Factory setting: Abort</p>
Ident number (Ident_Number) Display Slot: 0 Index: 66	<p>Displays the device identification number and the selected device master data (GSD file). Select the device master data (GSD file) via the "Ident number sel" parameter (→ ¶ 158).</p> <p>Cerabar M:</p> <ul style="list-style-type: none"> ▪ 0x9700: Profile GSD ▪ 0x1553: Device-specific GSD (factory setting) ▪ 0x151C: Device-specific GSD. The device behaves like a Cerabar M PMC41, PMC45, PMP41, PMP45, PMP46, PMP48. → See Operating Instructions BA00222P. <p>Deltabar M:</p> <ul style="list-style-type: none"> ▪ 0x9700: Profile GSD ▪ 0x1554: Device-specific GSD (factory setting) <p>Deltapilot M:</p> <ul style="list-style-type: none"> ▪ 0x9700: Profile GSD ▪ 0x1555: Device-specific GSD (factory setting) ▪ 0x1503: Device-specific GSD. The device behaves like a Deltapilot S DB50, DB50L, DB51, DB52 or DB53. → See Operating Instructions BA00164F.
Check conf. Display Slot: 0 Index: 67	<p>Function to check whether the configuration of a Class 1 master was accepted in the device for cyclic data exchange.</p> <p>Display:</p> <ul style="list-style-type: none"> ▪ 0 (configuration not OK) ▪ 1 (configuration OK) <p>Factory setting: 0</p>
Order number Display Slot: 0 Index: 69	<p>Device order code.</p> <p>Factory setting: As defined per order.</p>
Tag location Entry Slot: 0 Index: 70	User ID description of the slot module location.

Expert → Kommunikation → Physical Block → PB Endress+Hauser Parameter	
Parameter name	Description
Signature Entry Slot: 0 Index: 71	Enter the signature. Factory setting: As per order specifications
ENP version Display Slot: 0 Index: 72	This parameter indicates the version of the standard for electronic nameplates supported by the device. Factory setting: 2.02.00
Device diag. Display Slot: 0 Index: 73	Contains the device diagnostic in bit-encoded format (bit string). Allows access to all the diagnostic data of the device via one single acyclic read command.
Ext. order code Display Slot: 0 Index: 74	Display the extended order code. Factory setting As per order specifications
Service locking Entry Slot: 0 Index: 75	Internal service parameter.
Up/DI feature Display Slot: 0 Index: 76	Describes the function supported by the device. Factory setting 3
Updl control Display Slot: 0 Index: 77	Control parameter for parameter transaction. Factory setting passive
Updl status Display Slot: 0 Index: 78	Status information on the current status of the parameter transaction. Factory setting Data transfer status OK
Updl veri delay Entry Slot: 0 Index: 79	Delay between the end of the download and the activation of the new configuration. After this delay, the "Updl status" parameter must be updated correctly. A device restart may be required. Factory setting 120
Up/DI rev Display Slot: 0 Index: 80	Version of the upload/download specification. Factory setting 1
Config. counter Display Slot: 0 Index: 89	Displays the configuration counter. This counter is increased by 1 every time a configuration parameter or group is changed. The counter counts up to 65535 and then starts again at zero.
Operating hours Display Slot: 0 Index: 90	Displays the operating hours of the device. This parameter cannot be reset.

Expert → Kommunikation → Physical Block → PB Endress+Hauser Parameter	
Parameter name	Description
Sim. error no. Entry Slot: 0 Index: 91	Enter the diagnostic message number. → See also "Simulation mode". Prerequisite: <ul style="list-style-type: none"> ▪ "Simulation mode" = Alarm/warning Value when switched on: 484 (Simulation mode active)
Sim. messages Entry Slot: 0 Index: 92	Enter the message number for simulation. Prerequisite: <ul style="list-style-type: none"> ▪ Simulation = alarm/warning Factory setting: 484 "Simul error" (simulation active)
Language Options Slot: 0 Index: 93	Select language. Options: <ul style="list-style-type: none"> ▪ English ▪ Possibly another language (as selected when ordering the device) ▪ One further language (language of the manufacturing plant) Factory setting: English
Device name str. Display Slot: 0 Index: 94	Displays the name of the device. Possible names: Cerabar M, Deltabar M or Deltapilot M
Display mode Options Slot: 0 Index: 95	Specify the contents for the first line of the onsite display in the measuring mode. Options: <ul style="list-style-type: none"> ▪ Main value only (value+bar graph) ▪ External value1 only (value+status) ▪ All alternating (main value+secondary value+Ext. value 1+Ext. val. 2 (259)) Ext. value 1 and Ext. val. 2 (259) are only displayed if the PLC sends these values to the device. Factory setting: Main value only
Add. disp. value Options Slot: 0 Index: 96	Specify the contents for the second line of the onsite display in the measuring mode. Options: <ul style="list-style-type: none"> ▪ No value ▪ Pressure ▪ Main value (%) ▪ Totalizer 1 (Deltabar M) ▪ Totalizer 2 (Deltabar M) ▪ Temperature (Cerabar/Deltapilot) The options depend on the measuring mode chosen. Factory setting: No value
Format 1st value Options Slot: 0 Index: 97	Specify the number of places after the decimal point for the value displayed in the main line. Options: <ul style="list-style-type: none"> ▪ Auto ▪ x ▪ x.x ▪ x.xx ▪ x.xxx ▪ x.xxxx ▪ x.xxxxx Factory setting: Auto

Expert → Kommunikation → Physical Block → PB Endress+Hauser Parameter	
Parameter name	Description
Format 1st value Display Slot: 0 Index: 98	Specify the number of places after the decimal point for the value displayed in the main line. Options: <ul style="list-style-type: none"> ■ Auto ■ x ■ x.x ■ x.xx ■ x.xxx ■ x.xxxx ■ x.xxxxx Factory setting: Auto
Status (Device Status) Display Slot: 0 Index: 99	Provides information on the current status of the device. Display: <ul style="list-style-type: none"> ■ Good ■ Failure ■ Function check ■ Maintenance req. ■ Out of spec.
Format ext. val. 2 Options Slot: 0 Index: 100	Specify the number of places after the decimal point for the value displayed in the main line. Options: <ul style="list-style-type: none"> ■ x.x ■ x.xx ■ x.xxx ■ x.xxxx ■ x.xxxxx Factory setting: x.x
Advanced diagnostics 7 (Diag add ext.) Display Slot: 0 Index: 101	This parameter displays bit-encoded manufacturer-specific alarms and warnings that are pending. Several alarm messages can occur at any one time. In addition, the "Diag extension" parameter (→ 157) can display additional alarm messages and warnings. Factory setting: 0x0, 0x0
Diag mask add ext. Display Slot: 0 Index: 102	This parameter describes what manufacturer-specific alarms and warnings are supported by the device. Bit = 0: alarm is not supported; Bit = 1: alarm is supported.
Electr. serial no. Display Slot: 0 Index: 103	Displays the serial number of the main electronics (11 alphanumeric characters).
Diagnostic code Display Slot: 0 Index: 104	Displays the current message present. → See also these Operating Instructions, → Chap. 11.1 "Messages". The "Status" (Slot 0 Index 99) field and the "Diagnostic code" parameter display the message with the highest priority.
Sw build nr. Display Slot: 0 Index: 105	This parameter displays the software build number.
Lockstate Display Slot: 0 Index: 106	Displays the current locking status of the device or conditions that can lock the device (hardware locking, software locking).

Expert → Kommunikation → Physical Block → PB Endress+Hauser Parameter	
Parameter name	Description
Com.err.counters Display Slot: 0 Index: 107	This parameter is a structured parameter and monitors PROFIBUS communication-specific errors on the lowest communication layers. "Frame CRC error": number of received frames with a PA CRC error. "Frame delim. err.": number of received frames with an incorrect ASIC start delimitation character. "Frame length err.": number of received frames with incorrect number of the received byte. "Frame retry err.": number of time the master has tried to run a retry request. "Frame type error.": number of received frames with a damaged first frame delimitation character.
Addressing Display Slot: 0 Index: 108	Displays the addressing mode: via hardware (DIP switch) or software. Factory setting: Software
Alarm behav. P Options Slot: 0 Index: 109	Set the measured value status for when the sensor limits are exceeded or undershot. Options: <ul style="list-style-type: none"> ▪ Warning The device continues measuring. An error message is displayed. "UNCERTAIN" is displayed for the measured value status. ▪ Alarm "BAD" is displayed for the measured value status. An error message is displayed. Factory setting: Warning
Maintenance instructions Display Slot: 0 Index: 110	Displays the diagnostic message with the highest priority currently present (Record with the 10 highest active warnings/error messages).
Operator code Entry Slot: 0 Index: 111	Use this function to enter a code to lock or unlock operation. User input: <ul style="list-style-type: none"> ▪ To lock: Enter a number ≠ the release code (value range: 0 to 9999). ▪ To unlock: Enter the release code.  The release code is "0" in the order configuration. Another release code can be defined in the "Code definition" parameter. If the user has forgotten the release code, the release code can be visible by entering the number "5864". Factory setting: 0
Format ext. val. 1 Options Slot: 0 Index: 112	Specify the number of places after the decimal point for the value displayed in the main line. Options: <ul style="list-style-type: none"> ▪ x.x ▪ x.xx ▪ x.xxx ▪ x.xxxx ▪ x.xxxxx Factory setting: x.x
Reset Entry Slot: 0 Index: 113	Reset parameters completely or partially to the factory values or order configuration by entering a reset code. Factory setting: 0

Expert → Kommunikation → Physical Block → PB Endress+Hauser Parameter	
Parameter name	Description
Code definition Entry Slot: 0 Index: 114	Use this function to enter a release code with which the device can be unlocked. User input: <ul style="list-style-type: none"> A number between 0 and 9999 Factory setting: 0
DIP switch Display Slot: 0 Index: 115	Displays the status of the active DIP switches.
Last diag. code Display Slot: 0 Index: 116	Record with the last diagnostic message that occurred and was rectified.  <ul style="list-style-type: none"> Digital communication: the last message is displayed. The messages listed in the Last diag. code parameter can be deleted via the "Reset logbook" parameter.
Instructions Display Slot: 0 Index: 117	Instructions for resolving the highest active warning/error message.
Download select. Display Slot: 0 Index: 118	Select the data records for the upload/download function in Fieldcare and PDM. Prerequisite: DIP switch 1, 3, 4 and 5 set to "OFF", DIP switch 2 set to "ON" (see picture in Chap. 6.2.1)). A download with the "Configuration copy" factory setting causes the device to download all the parameters required for a measurement. The setting "Electronics replace" only takes effect if an appropriate release code is entered in the "Operator code" parameter. Options: <ul style="list-style-type: none"> Configuration copy: With this option, general configuration parameters are overwritten except for the serial number, order number, calibration, position adjustment, and application. Device replacement: With this option, general configuration parameters are overwritten except for the serial number, order number, calibration and position adjustment. Electronics replace: This option contains all parameters from "Configuration copy" and "Device replacement" and: "position adjustment", "sensor trimm", "serial number", "order number". Factory setting: Configuration copy
PB view 1 Display Slot: 0 Index: 126	Group of Physical Block parameters that are read as one via a communication request. The "PB view 1" comprises: <ul style="list-style-type: none"> Static rev. no. Block mode Alarm summary Diagnosis

9.5.3 Analog Input Block 1 / Analog Input Block 2

Expert → Communication → Analog Input 1/Analog Input 2 → AI Standard Parameter	
Parameter name	Description
Block object Display AI1 Slot: 1 AI2 Slot: 2 Index: 16	<p>The "Block object" parameter is a structured parameter consisting of 13 elements. This parameter describes the characteristics of the Analog Input Block.</p> <p>Reserved profile parameter</p> <ul style="list-style-type: none"> 250 = not used <p>Block object</p> <ul style="list-style-type: none"> 2 = Function Block <p>Parent class</p> <ul style="list-style-type: none"> 1 = Input <p>Class</p> <ul style="list-style-type: none"> 1 = Analog Input <p>Device rev.</p> <ul style="list-style-type: none"> 1 <p>Device rev. comp</p> <ul style="list-style-type: none"> 1 <p>DD_revision</p> <ul style="list-style-type: none"> 0 (for future use) <p>Profile</p> <ul style="list-style-type: none"> Number of the PROFIBUS PA profile in the PNO 0x40, 0x02 (compact class B) <p>Profile revision</p> <ul style="list-style-type: none"> Displays the profile version, here: 0x302 (Profile 3.02) <p>Execution time</p> <ul style="list-style-type: none"> 0 (for future use) <p>No. of parameters</p> <ul style="list-style-type: none"> Number of parameters of the Analog Input Block, here: 46 <p>Index of View 1</p> <ul style="list-style-type: none"> Address of the "AI view 1" parameter, here: AI1 = 0x01, 0x3E; AI2 = 0x02, 0x3E <p>Number of view lists</p> <ul style="list-style-type: none"> 1 = The Block contains one "View object".
Static rev. no. Display AI1 Slot: 1 AI2 Slot: 2 Index: 17	<p>Displays the static revision for the parameters of the Analog Input Block. The counter is incremented by one with each change of a static parameter of the Analog Input Block. The counter counts up to 65535 and then starts again at zero.</p> <p>Factory setting: 0</p>
TAG Entry AI1 Slot: 1 AI2 Slot: 2 Index: 18	<p>Enter device tag e.g. TAG number (max. 32 alphanumeric characters).</p> <p>Factory setting: _____ or as per order specifications</p>
Strategy Entry AI1 Slot: 1 AI2 Slot: 2 Index: 19	<p>Enter user-specific value for grouping and thus faster evaluation of the blocks. Grouping takes place by entering the same numerical value for the "Strategy" parameter of the block in question.</p> <p>Input range: 0 to 65535</p> <p>Factory setting: 0</p>
Alert key Entry AI1 Slot: 1 AI2 Slot: 2 Index: 20	<p>Enter the user-specific value (e.g. identification number of the plant unit). The process control system can use this information to sort alarms and events that were generated by this block.</p> <p>Input range: 0 to 255</p> <p>Factory setting: 0</p>

Expert → Communication → Analog Input 1/Analog Input 2 → AI Standard Parameter	
Parameter name	Description
Target mode Options AI1 Slot: 1 AI2 Slot: 2 Index: 21	Select the desired block mode. Options: <ul style="list-style-type: none"> ▪ Automatic (Auto) ▪ Manual (Man) ▪ Out of service (O/S) Factory setting: Automatic (Auto)
Block mode Display AI1 Slot: 1 AI2 Slot: 2 Index: 22	The "Block mode" parameter is a structured parameter consisting of three elements. PROFIBUS makes a distinction between the following block modes: automatic mode (Auto), manual user intervention (Man) and out of service (O/S). Actual mode <ul style="list-style-type: none"> ▪ Displays the current block mode. ▪ Factory setting: automatic (Auto) Permitted mode <ul style="list-style-type: none"> ▪ Displays the modes supported by the block. ▪ Factory setting: 152 = automatic (Auto), manual user intervention or out of service Normal mode <ul style="list-style-type: none"> ▪ Displays the normal working mode of the block. ▪ Factory setting: automatic (Auto)
Alarm summary Display AI1 Slot: 1 AI2 Slot: 2 Index: 23	The "Alarm summary" parameter is a structured parameter consisting of four elements. Current alarm summary <ul style="list-style-type: none"> ▪ Displays the current alarms ▪ Factory setting: 0x0, 0x0

Expert → Communication → Analog Input 1/Analog Input 2 → AI Endress+Hauser Parameter	
Parameter name	Description
Batch information Entry AI1 Slot: 1 AI2 Slot: 2 Index: 24	The "Batch information" parameter is a structured parameter consisting of four elements. This parameter is used in batch processes in accordance with IEC 61512 Part 1 (ISA S88). The "Batch information" parameter is required in a decentralized automation system to identify the input channels used. In addition, the errors occurring for the current batch process can also be displayed. Batch ID <ul style="list-style-type: none"> ▪ Enter the ID of a batch application so you can assign device messages, such as alarms etc. Batch unit (no. of recipe unit procedure or of the unit) <ul style="list-style-type: none"> ▪ Enter the recipe code required for the batch application or the related unit, such as the reactor for example. Batch operation <ul style="list-style-type: none"> ▪ Enter the recipe currently available. Batch phase <ul style="list-style-type: none"> ▪ Enter the current recipe phase.
Output value (Out Value) Display/Entry AI1 Slot: 1 AI2 Slot: 2 Index: 26	The "Output value (Out Value)" parameter is a structured parameter consisting of two elements. Output value (Out Value) <ul style="list-style-type: none"> ▪ Displays the output value (Out Value) of the Analog Input Block. Out status <ul style="list-style-type: none"> ▪ Displays the status of the Output value (Out Value)  <p>If the "MAN" (manual) block mode was selected by means of the "Block mode" parameter, the output value (Out Value) "Output value (Out Value)" and its status can be specified manually here.</p>

Expert → Communication → Analog Input 1/Analog Input 2 → AI Endress+Hauser Parameter	
Parameter name	Description
Proc value scale Entry AI1 Slot: 1 AI2 Slot: 2 Index: 27	Scale the input value of the Analog Input Block. Lower value: <ul style="list-style-type: none"> ▪ Enter the lower value for the input value of the Analog Input Block. ▪ Factory setting: 0 Upper value: <ul style="list-style-type: none"> ▪ Enter the upper value for the input value of the Analog Input Block. ▪ Factory setting: 100 Example: → 151
Output scale Entry AI1 Slot: 1 AI2 Slot: 2 Index: 28	Scale the output value (Out Value) of the Analog Input Block. → See also this table, "Proc value scale" parameter description. Lower value: <ul style="list-style-type: none"> ▪ Enter the lower limit for the output value (Out Value) of the Analog Input Block. ▪ Factory setting: 0 Upper value: <ul style="list-style-type: none"> ▪ Enter the upper limit for the output value (Out Value) of the Analog Input Block. ▪ Factory setting: 100 Unit: <ul style="list-style-type: none"> ▪ Select the unit. The unit selected here does not have any effect on the scaling. This unit is only editable in the operating program. ▪ Factory setting: % Decimal point: <ul style="list-style-type: none"> ▪ Specify the number of decimal places for the output value (Out Value). ▪ Factory setting: 0
Characterization Options AI1 Slot: 1 AI2 Slot: 2 Index: 29	This parameter is used to set the characteristic type for the Analog Input Block ever linear.
Channel Entry AI1 Slot: 1 AI2 Slot: 2 Index: 30	This parameter is used to assign a process variable of the Transducer Block to the input of the Analog Input Block. AI2 options: <ul style="list-style-type: none"> ▪ Pressure (0x011D) ▪ Level before lin. (0x0152) ▪ Totalizer 2 (0x18A) (Deltabar) ▪ Sensor temperature (0x011B) (Deltapilot/Cerabar) Factory setting: AI1: Measured value (digital value 0x0112) (fixed setting) AI2: Pressure (digital value 0x011D)
Filt. time const. Entry AI1 Slot: 1 AI2 Slot: 2 Index: 32	Enter the filter time constant for the 1st order digital filter. This time is required in order for 63 % of a change in the Analog Input Block (input value) to have an effect on the "Output value (Out Value)". → See also the "Damping" parameter description (→ 190). If the "MAN" (manual) block mode was selected by means of the "Target mode" parameter, the time entered here does not affect the output value (Out Value). Factory setting: 0.0 s

Expert → Communication → Analog Input 1/Analog Input 2 → AI Endress+Hauser Parameter	
Parameter name	Description
Fail safe mode Options AI1 Slot: 1 AI2 Slot: 2 Index: 33	<p>If the Analog Input Block receives an input value or simulation value with the status BAD, the Analog Input Block continues working with the failsafe mode defined by means of this parameter.</p> <p>The following options are available by means of the "Fail safe mode" parameter:</p> <ul style="list-style-type: none"> ▪ Last valid out val. The last valid value is used for further processing with the status UNCERTAIN. ▪ Fail safe value The value specified by means of the "Failsafe default" parameter is used for further processing with the status UNCERTAIN. → See this table, "Failsafe default" parameter description. ▪ Status BAD The current value is used for further processing with the status BAD. <p></p> <p>The BAD status is anyway activated if the "Out of service" (O/S) option was selected by means of the "Target mode" parameter.</p> <p>Factory setting: Last valid out val.</p>
Failsafe default Entry AI1 Slot: 1 AI2 Slot: 2 Index: 34	<p>Enter the value for the "Fail safe value" option selected via the "Fail safe mode" parameter. → See also this table, "Fail safe mode" parameter description.</p> <p>Factory setting: 0.0000 %</p>

Expert → Communication → Analog Input 1/Analog Input 2 → AI Endress+Hauser Parameter	
Parameter name	Description
Limit hysteresis Entry AI1 Slot: 1 AI2 Slot: 2 Index: 35	<p>Enter hysteresis value for the upper and lower alarm value or critical alarm value. The alarm conditions remain active as long as the measured value is in the hysteresis.</p> <p>The hysteresis affects the following alarm or critical alarm limit values:</p> <ul style="list-style-type: none"> ■ "Upper limit alarm": upper critical alarm limit value ■ "Upper limit warning": upper alarm limit value ■ "Lower limit warning": lower alarm limit value ■ "Lower limit alarm": lower critical alarm limit value <p style="text-align: right; font-size: small;">A0030353</p> <p><i>Fig. 42: Illustration of the output value (Out Value) with limit values and hysteresis as well as the alarms "Upper limit alarm", "Upper limit warning", "Lower limit warning" and "Lower limit alarm"</i></p> <p>Input range: 0.0 to 50.0 % with regard to the range of the "Output scale" group (→ 168)</p> <p>Factory setting: 0.5000 %</p>
Upper limit alarm Entry AI1 Slot: 1 AI2 Slot: 2 Index: 37	<p>Enter upper critical limit value. If the "Output value (Out Value)" exceeds this limit value, the "Upper limit alarm" parameter displays an alarm message. → See also this table, "Limit hysteresis".</p> <p>Factory setting: 3.4028e+038 %</p>
Upper limit warning Entry AI1 Slot: 1 AI2 Slot: 2 Index: 39	<p>Enter upper limit value. If the "Output value (Out Value)" exceeds this limit value, the "Upper limit warning" parameter displays an alarm message. → See also this table, "Limit hysteresis" parameter description.</p> <p>Factory setting: 3.4028e+038 %</p>

Expert → Communication → Analog Input 1/Analog Input 2 → AI Endress+Hauser Parameter	
Parameter name	Description
Lower limit warning Entry AI1 Slot: 1 AI2 Slot: 2 Index: 41	Enter lower limit value. If the "Output value (Out Value)" drops below this limit value, the "Lower limit warning" parameter displays an alarm message. → See also this table, "Limit hysteresis" parameter description. Factory setting: -3.4028e+038 %
Lower limit alarm Entry AI1 Slot: 1 AI2 Slot: 2 Index: 43	Enter lower critical limit value. If the "Output value (Out Value)" drops below this limit value, the "Lower limit alarm" parameter displays an alarm message. → See also this table, "Limit hysteresis" parameter description. Factory setting: -3.4028e+038 %
Upper limit alarm Display AI1 Slot: 1 AI2 Slot: 2 Index: 46	The "Upper limit alarm" parameter is a structured parameter consisting of four elements. The parameter displays the status of the upper critical limit value alarm. → 170, "Limit hysteresis", graphic. Status <ul style="list-style-type: none"> ■ Displays the current status of the "Upper limit alarm" e.g. alarm still active, alarm reported to control level etc. ■ Factory setting: 0 Alarm output value (Out Value) <ul style="list-style-type: none"> ■ Displays the value that violated the upper critical limit ("Upper limit alarm"). ■ Factory setting: 0.0000 %
Upper limit warning Display AI1 Slot: 1 AI2 Slot: 2 Index: 47	The "Upper limit warning" parameter is a structured parameter consisting of four elements. The parameter displays the status of the upper limit value alarm. → 170, "Limit hysteresis", graphic. Status <ul style="list-style-type: none"> ■ Displays the current status of the "Upper limit warning" e.g. alarm still active, alarm reported to control level etc. ■ Factory setting: 0 Warning output value (Out Value) <ul style="list-style-type: none"> ■ Displays the value that violated the upper limit (Upper limit warning). ■ Factory setting: 0.0000 %
Lower limit warning Display AI1 Slot: 1 AI2 Slot: 2 Index: 48	The "Lower limit warning" parameter is a structured parameter consisting of four elements. The parameter displays the status of the lower limit value alarm. → 170, "Limit hysteresis", graphic. Status <ul style="list-style-type: none"> ■ Displays the current status of the "Lower limit warning" e.g. alarm still active, alarm reported to control level etc. ■ Factory setting: 0 Warning output value (Out Value) <ul style="list-style-type: none"> ■ Displays the value that violated the lower limit ("Lower limit warning"). ■ Factory setting: 0.0000 %
Lower limit alarm Display AI1 Slot: 1 AI2 Slot: 2 Index: 49	The "Lower limit alarm" parameter is a structured parameter consisting of four elements. The parameter displays the status of the lower critical limit value alarm. → 170, "Limit hysteresis", graphic. Status <ul style="list-style-type: none"> ■ Displays the current status of the "Lower limit alarm" e.g. alarm still active, alarm reported to control level etc. ■ Factory setting: 0 Alarm output value (Out Value) <ul style="list-style-type: none"> ■ Displays the value that violated the lower critical limit ("Lower limit alarm"). ■ Factory setting: 0.0000 %



Expert → Communication → Analog Input 1/Analog Input 2 → AI Endress+Hauser Parameter	
Parameter name	Description
Simulate Entry AI1 Slot: 1 AI2 Slot: 2 Index: 50	<p>The "Simulate" parameter is a structured parameter consisting of three elements. This parameter is used to simulate the input value and status of the Analog Input Block. As this value runs through the complete algorithm, the behavior of the Analog Input Block can be checked.</p> <p>Simulation</p> <ul style="list-style-type: none"> ▪ 0: Simulation mode switched off ▪ 1: Simulation mode switched on <p>Simulation value</p> <ul style="list-style-type: none"> ▪ This element is displayed if the simulation mode was enabled via the simulation element. Depending on the settings for the "Measuring mode (005)", level selection and unit parameters, you can enter a pressure, level, volume, mass or flow value here. ▪ Factory setting: 0.0 <p>Status</p> <ul style="list-style-type: none"> ▪ This element is displayed if the simulation mode was enabled via the simulation element. Enter the status for the simulation value. ▪ Factory setting: 128 (GOOD)
Unit text Entry AI1 Slot: 1 AI2 Slot: 2 Index: 51	<p>Enter text (max. 16 alphanumeric characters).</p> <p>Factory setting: Empty field</p>
PV scale unit Display AI1 Slot: 1 AI2 Slot: 2 Index: 61	<p>This parameter describes the unit of the process variable of the Transducer Block which is assigned to this Analog Input Block via the channel (see "Channel" parameter → 168).</p>
AI view 1 Display AI1 Slot: 1 AI2 Slot: 2 Index: 62	<p>Group of Analog Input Block parameters that are read as one via a communication request.</p> <p>The "AI view 1" comprises:</p> <ul style="list-style-type: none"> ▪ Static rev. no. ▪ Block mode ▪ Alarm summary ▪ Output value (Out Value)

9.5.4 Analog Output Block 1 / Analog Output Block 2

Expert → Communication → Analog Output 1/Analog Output 2 → AO Standard Parameter	
Parameter name	Description
Block object Display AO1 Slot: 3 AO2 Slot: 4 Index: 16	The "Block object" parameter is a structured parameter consisting of 13 elements. This parameter describes the characteristics of the Analog Output Block. Reserved profile parameter <ul style="list-style-type: none"> 250 = not used Block object <ul style="list-style-type: none"> 2 = Function Block Parent class <ul style="list-style-type: none"> 2 = Output Class <ul style="list-style-type: none"> 128 = Endress+Hauser Analog Output Block (DAO_EH) Device rev. <ul style="list-style-type: none"> 1 Device rev. comp <ul style="list-style-type: none"> 1 DD-revision <ul style="list-style-type: none"> 0 (for future use) Profile <ul style="list-style-type: none"> Number of the PROFIBUS PA profile in the PNO 0x40, 0x02 (compact class B) Profile revision <ul style="list-style-type: none"> Displays the profile version, here: 0x302 (Profile 3.02) Execution time <ul style="list-style-type: none"> 0 (for future use) No. of parameters <ul style="list-style-type: none"> Number of parameters of the Endress+Hauser Analog Output, here: 23 Index of View 1 <ul style="list-style-type: none"> Address of the "AO view 1" parameter, here: AO1 = 0x03, 0x27; AO2 = 0x04, 0x27 Number of view lists <ul style="list-style-type: none"> 1 = The Block contains one "View object".
Static rev. no. Display AO1 Slot: 3 AO2 Slot: 4 Index: 17	Displays the static revision counter for the parameters of the Analog Output Block. The counter is incremented by one with each change of a static parameter of the Analog Output Block. The counter counts up to 65535 and then starts again at zero. Factory setting: 0
TAG Entry AO1 Slot: 3 AO2 Slot: 4 Index: 18	Enter device tag e.g. TAG number (max. 32 alphanumeric characters). Factory setting: _____ or as per order specifications
Strategy Entry AO1 Slot: 3 AO2 Slot: 4 Index: 19	Enter user-specific value for grouping and thus faster evaluation of the blocks. Grouping takes place by entering the same numerical value for the "Strategy" parameter of the block in question. Input range: 0 to 65535 Factory setting: 0

Expert → Communication → Analog Output 1/Analog Output 2 → AO Standard Parameter	
Parameter name	Description
Alert key Entry AO1 Slot: 3 AO2 Slot: 4 Index: 20	Enter the user-specific value (e.g. identification number of the plant unit). The process control system can use this information to sort alarms and events that were generated by this block. Input range: 0 to 255 Factory setting: 0
Target mode Options AO1 Slot: 3 AO2 Slot: 4 Index: 21	Select the desired block mode. Options: <ul style="list-style-type: none"> ▪ Automatic (Auto) ▪ Manual (Man) ▪ Out of service (O/S) Factory setting: Automatic (Auto)
Block mode Display AO1 Slot: 3 AO2 Slot: 4 Index: 22	The "Block mode" parameter is a structured parameter consisting of three elements. PROFIBUS makes a distinction between the following block modes: automatic mode (Auto), manual user intervention (Man) and out of service (O/S). Actual mode <ul style="list-style-type: none"> ▪ Displays the current block mode. ▪ Factory setting: automatic (Auto) Permitted mode <ul style="list-style-type: none"> ▪ Displays the modes supported by the block. ▪ Factory setting: 152 = automatic (Auto), manual user intervention or out of service Normal mode <ul style="list-style-type: none"> ▪ Displays the normal working mode of the block. ▪ Factory setting: automatic (Auto)
Alarm summary Display AO1 Slot: 3 AO2 Slot: 4 Index: 23	The "Alarm summary" parameter is a structured parameter consisting of four elements. Current alarm summary <ul style="list-style-type: none"> ▪ Displays the current alarms ▪ Factory setting: 0x0, 0x0

Expert → Communication → Analog Output 1/Analog Output 2 → AO Endress+Hauser Parameter	
Parameter name	Description
Batch information Entry AO1 Slot: 3 AO2 Slot: 4 Index: 24	The "Batch information" parameter is a structured parameter consisting of four elements. This parameter is used in batch processes in accordance with IEC 61512 Part 1 (ISA S88). The "Batch information" parameter is required in a decentralized automation system to identify the input channels used. In addition, the errors occurring for the current batch process can also be displayed. Batch ID <ul style="list-style-type: none"> ▪ Enter the ID of a batch application so you can assign device messages, such as alarms etc. Batch unit (no. of recipe unit procedure or of the unit) <ul style="list-style-type: none"> ▪ Enter the recipe code required for the batch application or the related unit, such as the reactor for example. Batch operation <ul style="list-style-type: none"> ▪ Enter the recipe currently available. Batch phase <ul style="list-style-type: none"> ▪ Enter the current recipe phase.

Expert → Communication → Analog Output 1/Analog Output 2 → AO Endress+Hauser Parameter	
Parameter name	Description
Input value Display AO1 Slot: 3 AO2 Slot: 4 Index: 26	The "Input value" parameter is a structured parameter consisting of two elements. Input value ■ Displays the input value of the Analog Output Block. Input status ■ Displays the status of the input value  If the "MAN" (manual) block mode was selected by means of the "Block mode" parameter, the "Input value" and its status can be specified manually here.
Channel Display AO1 Slot: 3 AO2 Slot: 4 Index: 27	This parameter is used to assign the output of the Analog Output Block to the received parameter of the Transducer Block. Factory setting: "Ext. value 1" fixed assignment to the external value 1 for the Analog Output 1 "Ext. value 2" fixed assignment to the external value 2 for the Analog Output 2
Data size Display AO1 Slot: 3 AO2 Slot: 4 Index: 28	Size of the "Output value (Out Value)" parameter in number of bytes, without status byte. Factory setting: 4
Data max. size Display AO1 Slot: 3 AO2 Slot: 4 Index: 29	Maximum size of the "Output value (Out Value)" parameter in number of bytes, with status byte.
Fail safe time Entry AO1 Slot: 3 AO2 Slot: 4 Index: 32	Time in seconds since the failure was detected until action on the part of the block if the condition persists. Factory setting: 0
Fail safe mode Options AO1 Slot: 3 AO2 Slot: 4 Index: 33	If the Analog Output Block receives an input value with the status BAD, the Analog Output Block continues working with the failsafe mode defined by means of this parameter. The following options are available by means of the "Fail safe mode" parameter: ■ Last valid out val. The last valid value is used for further processing with the status UNCERTAIN. ■ Fail safe value The value specified by means of the "Failsafe default" parameter is used for further processing with the status UNCERTAIN. → See this table, "Failsafe default" parameter description. ■ Status bad The current value is used for further processing with the status BAD.  The failsafe mode is anyway activated if the "Out of service" (O/S) option was selected by means of the "Target mode" parameter. Factory setting: Last valid out val.
Failsafe default Entry AO1 Slot: 3 AO2 Slot: 4 Index: 34	Enter the value for the "FsafeValue" option selected via the "Fail safe mode" parameter. → See also this table, "Fail safe mode" parameter description. Factory setting: 0.0000

Expert → Communication → Analog Output 1/Analog Output 2 → AO Endress+Hauser Parameter	
Parameter name	Description
Unit Entry AO1 Slot: 3 AO2 Slot: 4 Index: 35	This parameter describes the unit for the input value. Factory setting: Unknown
Output value (Out Value) Display AO1 Slot: 3 AO2 Slot: 4 Index: 36	The "Output value (Out Value)" parameter is a structured parameter consisting of two elements. Output value (Out Value) <ul style="list-style-type: none"> ▪ Displays the output value (Out Value) of the Analog Output Block. It is transmitted to the "Ext. val. 1" or "Ext. value 2" parameter via the channel. Out status <ul style="list-style-type: none"> ▪ Displays the status of the output value (Out Value).  If the "MAN" (manual) block mode was selected by means of the "Block mode" parameter, the "Output value (Out Value)" and its status can be written manually here.
AO view 1 Display AO1 Slot: 3 AO2 Slot: 4 Index: 39	Group of Analog Output Block parameters that are read as one via a communication request. The "AO view 1" comprises: <ul style="list-style-type: none"> ▪ Static rev. no. ▪ Block mode ▪ Alarm summary ▪ Input value ▪ Data size ▪ Data max. size

9.5.5 Totalizer Block (Deltabar M)

Expert → Communication → Totalizer 1 → ToT Standard Parameter	
Parameter name	Description
Block object Display Slot: 5 Index: 16	The "Block object" parameter is a structured parameter consisting of 13 elements. This parameter describes the characteristics of the Totalizer Block. Reserved profile parameter ■ 250 = not used Block object ■ 2 = Function Block Parent class ■ 5 = Calculation Class ■ 8 = Totalizer Device rev. ■ 1 Device rev. comp ■ 1 DD-revision ■ 0 (for future use) Profile ■ Number of the PROFIBUS PA profile in the PNO ■ 0x40, 0x02 (compact class B) Profile revision ■ Displays the profile version, here: 0x302 (Profile 3.02) Execution time ■ 0 (for future use) No. of parameters ■ Number of parameters for the totalizer, here: 36 Index of View 1 ■ Address of the "Tot view 1" parameter, here: 0x05, 0x34 Number of view lists ■ 1 = The Block contains one "View object".
Static rev. no. Display Index: 5 Slot: 17	Displays the static revision counter for the parameters of the Totalizer Block. The counter is incremented by one with each change of a static parameter of the Totalizer Block. The counter counts up to 65535 and then starts again at zero. Factory setting: 0
TAG Entry Slot: 5 Index: 18	Enter device tag e.g. TAG number (max. 32 alphanumeric characters). Factory setting: _____ or as per order specifications
Strategy Entry Slot: 5 Index: 19	Enter user-specific value for grouping and thus faster evaluation of the blocks. Grouping takes place by entering the same numerical value for the "Strategy" parameter of the block in question. Input range: 0 to 65535 Factory setting: 0
Alert key Entry Slot: 5 Index: 20	Enter the user-specific value (e.g. identification number of the plant unit). The process control system can use this information to sort alarms and events that were generated by this block. Input range: 0 to 255 Factory setting: 0

Expert → Communication → Totalizer 1 → ToT Standard Parameter	
Parameter name	Description
Target mode Options Slot: 5 Index: 21	Select the desired block mode. Options: <ul style="list-style-type: none"> ▪ Automatic (Auto) ▪ Manual (Man) ▪ Out of service (O/S) Factory setting: Automatic (Auto)
Block mode Display Slot: 5 Index: 22	The "Block mode" parameter is a structured parameter consisting of three elements. PROFIBUS makes a distinction between the following block modes: automatic mode (Auto), manual user intervention (Man) and out of service (O/S). Actual mode <ul style="list-style-type: none"> ▪ Displays the current block mode. ▪ Factory setting: automatic (Auto) Permitted mode <ul style="list-style-type: none"> ▪ Displays the modes supported by the block. ▪ Factory setting: 152 = automatic (Auto), manual user intervention or out of service Normal mode <ul style="list-style-type: none"> ▪ Displays the normal working mode of the block. ▪ Factory setting: automatic (Auto)
Alarm summary Display Slot: 5 Index: 23	The "Alarm summary" parameter is a structured parameter consisting of four elements. Current alarm summary <ul style="list-style-type: none"> ▪ Displays the current alarms ▪ Factory setting: 0x0, 0x0

Expert → Communication → Totalizer 1 → ToT Endress+Hauser Parameter	
Parameter name	Description
Batch information Entry Slot: 5 Index: 24	The "Batch information" parameter is a structured parameter consisting of four elements. This parameter is used in batch processes in accordance with IEC 61512 Part 1 (ISA S88). The "Batch information" parameter is required in a decentralized automation system to identify the input channels used. In addition, the errors occurring for the current batch process can also be displayed. Batch ID <ul style="list-style-type: none"> ▪ Enter the ID of a batch application so you can assign device messages, such as alarms etc. Batch unit (no. of recipe unit procedure or of the unit) <ul style="list-style-type: none"> ▪ Enter the recipe code required for the batch application or the related unit, such as the reactor for example. Batch operation <ul style="list-style-type: none"> ▪ Enter the recipe currently available. Batch phase <ul style="list-style-type: none"> ▪ Enter the current recipe phase.
Totalizer 1 Display Slot: 5 Index: 26	The "Totalizer 1" function block contains the value and the associated status of the Totalizer 1.
Eng. unit totalizer 1 Entry Slot: 5 Index: 27	Unit of the Totalizer 1. Factory setting: m ³

Expert → Communication → Totalizer 1 → ToT Endress+Hauser Parameter	
Parameter name	Description
Channel Entry Slot: 5 Index: 28	Describes the flow measured value channel which is calculated by the Transducer Block.
Total 1 value Entry Slot: 5 Index: 29	Set the totalizer to zero or a predefined value. Options: <ul style="list-style-type: none"> ▪ Totalize (normal function of the totalizer) ▪ Reset (totalizer is reset to zero) ▪ Preset (totalizer is set to a predefined value) Factory setting: Totalize
Totalizer 1 mode Options Slot: 5 Index: 30	This function block parameter controls the totalization behavior. The following options are available: <ul style="list-style-type: none"> ▪ Balanced: true arithmetic integration of the flow values. ▪ Positive flow only: only positive flow values are totalized. ▪ Negative flow only: only negative flow values are totalized. ▪ Hold: the totalizer stops totalizing. Factory setting: Pos. flow only
Total. 1 failsafe Options Slot: 5 Index: 31	Define the behavior of the totalizer in the case of an error. Options: <ul style="list-style-type: none"> ▪ Actual value (It is integrated with the current flow value on.) ▪ Hold: The totalizer is stopped and keeps its current value. ▪ Memory (the totalizer continues running with the last valid value) Factory setting: Actual value
Preset value Entry Slot: 5 Index: 32	Value for setting the totalizer to a predefined value, see option "Preset" of "Total 1 value". Factory setting: 0.0

Expert → Communication → Totalizer 1 → ToT Endress+Hauser Parameter	
Parameter name	Description
Limit hysteresis Entry Slot: 5 Index: 33	<p>Enter hysteresis value for the upper and lower alarm value or critical alarm value. The alarm conditions remain active as long as the measured value is in the hysteresis. The hysteresis affects the following alarm or critical alarm limit values:</p> <p>The hysteresis affects the following alarm or critical alarm limit values:</p> <ul style="list-style-type: none"> ■ "Upper limit alarm": upper critical alarm limit value ■ "Upper limit warning": upper alarm limit value ■ "Lower limit warning": lower alarm limit value ■ "Lower limit alarm": lower critical alarm limit value <div style="text-align: center;"> </div> <p style="text-align: right; font-size: small;">A0030353</p> <p><i>Fig. 43: Illustration of the output value (Totalizer 1) with limit values and hysteresis as well as the alarms "Upper limit alarm", "Upper limit warning", "Lower limit warning" and "Lower limit alarm"</i></p> <p>Factory setting: 0 m³</p>
Upper limit alarm Entry Slot: 5 Index: 34	<p>Enter upper critical limit value. If the "Totalizer 1" exceeds this limit value, the "Upper limit alarm" parameter displays an alarm message. → See also this table, "Limit hysteresis" parameter description.</p> <p>Factory setting: 3.4028e+038 m³</p>
Upper limit warning Entry Slot: 5 Index: 35	<p>Enter upper limit value. If the "Totalizer 1" exceeds this limit value, the "Upper limit warning" parameter displays an alarm message. → See also this table, "Limit hysteresis" parameter description.</p> <p>Factory setting: 3.4028e+038 m³</p>
Lower limit warning Entry Slot: 5 Index: 36	<p>Enter lower limit value. If the "Totalizer 1" drops below this limit value, the "Lower limit warning" parameter displays an alarm message. → See also this table, "Limit hysteresis" parameter description.</p> <p>Factory setting: -3.4028e+038 m³</p>

Expert → Communication → Totalizer 1 → ToT Endress+Hauser Parameter	
Parameter name	Description
Lower limit alarm Entry Slot: 5 Index: 37	Enter lower critical limit value. If the "Lower limit alarm" drops below this limit value, the "Lower limit alarm" parameter displays an alarm message. → See also this table, "Limit hysteresis" parameter description. Factory setting: -3.4028e+038 m ³
Upper limit alarm Display Slot: 5 Index: 38	The "Upper limit alarm" parameter is a structured parameter consisting of four elements. The parameter displays the status of the upper critical limit value alarm. → 180, "Limit hysteresis", graphic. Status <ul style="list-style-type: none"> ■ Displays the current status of the "Upper limit alarm" e.g. alarm still active, alarm reported to control level etc. ■ Factory setting: 0 Alarm output value (Out Value) <ul style="list-style-type: none"> ■ Displays the value that violated the upper critical limit ("Upper limit alarm"). ■ Factory setting: 0.0000 m³
Upper limit warning Display Slot: 5 Index: 39	The "Upper limit warning" parameter is a structured parameter consisting of four elements. The parameter displays the status of the upper limit value alarm. → 180, "Limit hysteresis", graphic. Status <ul style="list-style-type: none"> ■ Displays the current status of the "Upper limit warning" e.g. alarm still active, alarm reported to control level etc. ■ Factory setting: 0 Warning output value <ul style="list-style-type: none"> ■ Displays the value that violated the upper limit (Upper limit warning). ■ Factory setting: 0.0000 m³
Lower limit warning Display Slot: 5 Index: 48	The "Lower limit warning" parameter is a structured parameter consisting of four elements. The parameter displays the status of the lower limit value alarm. → 180, "Limit hysteresis", graphic. Status <ul style="list-style-type: none"> ■ Displays the current status of the "Lower limit warning" e.g. alarm still active, alarm reported to control level etc. ■ Factory setting: 0 Warning output value <ul style="list-style-type: none"> ■ Displays the value that violated the lower limit ("Lower limit warning"). ■ Factory setting: 0.0000 m³
Lower limit alarm Display Slot: 5 Index: 41	The "Lower limit alarm" parameter is a structured parameter consisting of four elements. The parameter displays the status of the lower critical limit value alarm. → 180, "Limit hysteresis", graphic. Status <ul style="list-style-type: none"> ■ Displays the current status of the "Lower limit alarm" e.g. alarm still active, alarm reported to control level etc. ■ Factory setting: 0 Alarm output value <ul style="list-style-type: none"> ■ Displays the value that violated the lower critical limit ("Lower limit alarm"). ■ Factory setting: 0.0000 m³
Tot view 1 Display Slot: 5 Index: 52	Group of Totalizer Block parameters that are read as one via a communication request. The "Tot view 1" comprises: <ul style="list-style-type: none"> ■ Static rev. no. ■ Block mode ■ Alarm summary ■ Totalizer 1

9.5.6 Transducer Block

Expert → Communication → Transducer Block → TB Standard Parameter	
Parameter name	Description
Block object Display Slot: 6 Index: 16	<p>The "Block object" parameter is a structured parameter consisting of 13 elements. This parameter describes the characteristics of the Transducer Block.</p> <p>Reserved profile parameter</p> <ul style="list-style-type: none"> 250 = not used <p>Block object</p> <ul style="list-style-type: none"> 3 = Transducer Block <p>Parent class</p> <ul style="list-style-type: none"> 1 = Pressure <p>Class</p> <ul style="list-style-type: none"> 7 = Differential pressure, gauge pressure, absolute pressure <p>Device rev.</p> <ul style="list-style-type: none"> 1 <p>Device rev. comp</p> <ul style="list-style-type: none"> 1 <p>DD_revision</p> <ul style="list-style-type: none"> 0 (for future use) <p>Profile</p> <ul style="list-style-type: none"> Number of the PROFIBUS PA profile in the PNO 0x40, 0x02 (compact class B) <p>Profile revision</p> <ul style="list-style-type: none"> Displays the profile version, here: 0x302 (Profile 3.02) <p>Execution time</p> <ul style="list-style-type: none"> 0 (for future use) <p>No. of parameters</p> <ul style="list-style-type: none"> Number of parameters for the transducer, here: 234 <p>Index of View 1</p> <ul style="list-style-type: none"> Address of the "TB View 1" parameter, here: 0x06, 0xFA <p>Number of view lists</p> <ul style="list-style-type: none"> 1 = The Block contains one "View object".
Static rev. no. Display Index: 6 Slot: 17	<p>Displays the static revision counter for parameters of the Transducer Block. The counter is incremented by one with each change of a static parameter of the Transducer Block. The counter counts up to 65535 and then starts again at zero.</p> <p>Factory setting: 0</p>
TAG Entry Slot: 6 Index: 18	<p>Enter device tag e.g. TAG number (max. 32 alphanumeric characters).</p> <p>Factory setting: _____ or as per order specifications</p>
Strategy Entry Slot: 6 Index: 19	<p>Enter user-specific value for grouping and thus faster evaluation of the blocks. Grouping takes place by entering the same numerical value for the "Strategy" parameter of the block in question.</p> <p>Input range: 0 to 65535</p> <p>Factory setting: 0</p>
Alert key Entry Slot: 6 Index: 20	<p>Enter the user-specific value (e.g. identification number of the plant unit). The process control system can use this information to sort alarms and events that were generated by this block.</p> <p>Input range: 0 to 255</p> <p>Factory setting: 0</p>



Expert → Communication → Transducer Block → TB Standard Parameter	
Parameter name	Description
Target mode Options Slot: 6 Index: 21	Select the desired block mode. Only the "Automatic (Auto)" mode can be selected for the Transducer Block. Options: <ul style="list-style-type: none"> ▪ Automatic (Auto) Factory setting: Automatic (Auto)
Block mode Display Slot: 6 Index: 22	The "Block mode" parameter is a structured parameter consisting of three elements. PROFIBUS makes a distinction between the following block modes: automatic mode (Auto), manual user intervention (Man) and out of service (O/S). The Transducer Block only works in the "Automatic (Auto)" mode. Actual mode <ul style="list-style-type: none"> ▪ Displays the current block mode. ▪ Factory setting: automatic (Auto) Permitted mode <ul style="list-style-type: none"> ▪ Displays the modes supported by the block. ▪ Factory setting: 8 = automatic (Auto) Normal mode <ul style="list-style-type: none"> ▪ Displays the normal working mode of the block. ▪ Factory setting: automatic (Auto)
Alarm summary Display Slot: 6 Index: 23	The "Alarm summary" parameter is a structured parameter consisting of four elements. Current alarm summary <ul style="list-style-type: none"> ▪ Displays the current alarms ▪ Factory setting: 0x0, 0x0

Expert → Communication → Transducer Block → TB Endress+Hauser Parameter	
Parameter name	Description
Sensor pressure Display Slot: 6 Index: 24	Displays the measured pressure before sensor trim, position adjustment and damping. → 132, Meas. pressure (020) , graphic
URL sensor Display Slot: 6 Index: 25	Displays the upper-range limit of the sensor.
LRL sensor Display Slot: 6 Index: 26	Displays the lower-range limit of the sensor.
Hi trim sensor Display Slot: 6 Index: 27	Sensor recalibration by entering a target pressure while simultaneously and automatically accepting a reference pressure present for the upper calibration point.
Lo trim sensor Entry Slot: 6 Index: 28	Sensor recalibration by entering a target pressure while simultaneously and automatically accepting a reference pressure present for the lower calibration point.
Minimum span Display Slot: 6 Index: 29	Displays the smallest possible span.

Expert → Communication → Transducer Block → TB Endress+Hauser Parameter	
Parameter name	Description
Press. eng. unit Options Slot: 6 Index: 30	Select the pressure unit. If a new pressure unit is selected, all pressure-specific parameters are converted and displayed with the new unit. Options: <ul style="list-style-type: none"> ▪ mbar, bar ▪ mmH2O, mH2O, ▪ inH2O, ftH2O ▪ Pa, kPa, MPa ▪ psi ▪ mmHg, inHg ▪ kgf/cm² Factory setting: mbar or bar depending on the sensor nominal measuring range, or as per order specifications
Corrected press. Display Slot: 6 Index: 31	Displays the measured pressure after sensor trim and position adjustment.  If this value is not equal to "0", it can be corrected to "0" by the position adjustment.
Sensor Meas. Type Display Slot: 6 Index: 32	Displays the sensor type. <ul style="list-style-type: none"> ▪ Deltabar M = differential ▪ Cerabar M with gauge pressure sensors = gauge ▪ Cerabar M with absolute pressure sensors = absolute ▪ Deltapilot M with gauge pressure sensors = gauge
Sensor serial no. Display Slot: 6 Index: 33	Displays the serial number of the sensor (11 alphanumeric characters).
Primary value Display Slot: 6 Index: 34	The "Primary value" parameter is a structured parameter consisting of two elements. Measured value <ul style="list-style-type: none"> ▪ Depending on the settings for the "Measuring mode (005)", Lin. mode (037) and unit parameters, a pressure, level, volume, mass or flow value is displayed here. Status <ul style="list-style-type: none"> ▪ Displays the status of the measured value
Primary value unit Display Slot: 6 Index: 35	This parameter describes the unit of the primary value depending on the "transmitter type".
Transmitter type Display Slot: 6 Index: 36	This parameter describes the measuring mode of the pressure transmitter. Options: <ul style="list-style-type: none"> ▪ Pressure ▪ Flow ▪ Level
Sensor Temp. (Cerabar/ Deltapilot) Display Slot: 6 Index: 43	The "Sensor Temp. (Cerabar/Deltapilot)" parameter is a structured parameter consisting of two elements. Sensor temp. <ul style="list-style-type: none"> ▪ Displays the temperature currently measured in the sensor. This can deviate from the process temperature. Status <ul style="list-style-type: none"> ▪ Displays the status of the measured temperature.

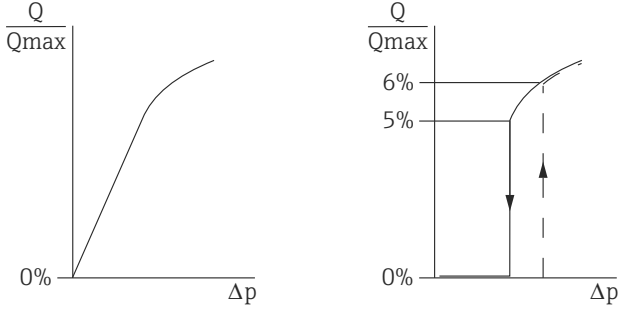
Expert → Communication → Transducer Block → TB Endress+Hauser Parameter	
Parameter name	Description
Temp. eng. unit. (Cerabar/Deltapilot) Options Slot: 6 Index: 44	Select the unit for the temperature measured values.  The setting affects the unit for the "Sensor temp." parameter. Options: <ul style="list-style-type: none"> ■ °C ■ °F ■ K Factory setting: °C
Value (sec val 1) Display Slot: 6 Index: 45	This parameter contains the pressure value and the status that is available for the function block.
Press. eng. unit Display Slot: 6 Index: 46	This parameter contains the pressure unit of the Value (sec val 1) parameter (= "Press. eng. unit").
Value (sec val 2) Display Slot: 6 Index: 47	This parameter contains the measured value after input scaling and the status that is available for the function block. The parameter contains the standardized pressure value without an engineering unit.
Sec val2 unit Display Slot: 6 Index: 48	This parameter contains the unit of the "Value (sec val 2)" parameter. The digital value, that corresponds "None" and is transmitted, is 1997 (PROFIBUS PA Profile).
Characterization Display Slot: 6 Index: 49	Type of characteristic. Options: <ul style="list-style-type: none"> ■ Linear ■ Linearization ■ Square root
Measuring range Entry Slot: 6 Index: 50	The "Measuring range" parameter is a structured parameter consisting of two elements. Full pressure <ul style="list-style-type: none"> ■ Enter the upper limit for the input value of the Transducer Block. ■ Factory setting: URL sensor (→ For the sensor upper range value, see "URL sensor".) Empty pressure <ul style="list-style-type: none"> ■ Enter the lower limit for the input value of the Transducer Block. ■ Factory setting: 0
Working range Entry Slot: 6 Index: 51	The "Working range" parameter is a structured parameter consisting of two elements. Full calib. <ul style="list-style-type: none"> ■ Enter the upper limit for the output value (Out Value) of the Transducer Block. ■ Factory setting: URL sensor (→ For the sensor upper range value, see "URL sensor".) Empty calib. <ul style="list-style-type: none"> ■ Enter the lower limit for the output value (Out Value) of the Transducer Block. ■ Factory setting: 0

Expert → Communication → Transducer Block → TB Endress+Hauser Parameter	
Parameter name	Description
Set low-flow cut-off Display Slot: 6 Index: 52	<p>Enter switch-on point of the flow-flow cut-off. The hysteresis between the switch-on point and the switch-off point is always 1 % of the maximum flow value.</p> <p>Input range: Switch-off point: 0 to 50 % of end flow value ("Max. flow (009)").</p>  <p style="text-align: right;"><small>A0025191</small></p> <p>Factory setting: 5 % (of the maximum flow value)</p>
Squareroot point Display Slot: 6 Index: 53	<p>Shows the number of value pairs of a linearization table. The value is calculated if the table is activated.</p>
Tab actual numb Display Slot: 6 Index: 54	<p>Contains the actual numbers of entries in the table. It is calculated when table transmission has ended.</p>
Line numb.: Display Slot: 6 Index: 55	<p>The "Line numb.:" parameter identifies which element in the table is currently in the "Tab xy value" parameter.</p>
Table max. number Display Slot: 6 Index: 56	<p>"Table max. number" is the maximum size (number of value pairs "X-value" and "Y value") of the table in the device.</p>
Table min. number Display Slot: 6 Index: 57	<p>For device-internal reasons (e.g. calculation), it is sometimes necessary to use a minimum number of table values. This number is provided in the "Table min. number" parameter.</p>
Simulation mode Options Slot: 6 Index: 58	<p>Select the function for entering the table.</p> <p>Options:</p> <ul style="list-style-type: none"> ▪ Clear table: deletes an active linearization table ▪ New operation: creates a new linearization table ▪ Accept input table: enables the linearization table entered ▪ Delete point: deletes a linearization point. ▪ Insert point: adds a new linearization point. <p>Factory setting: Clear table</p>
Status (characteristic) Display Slot: 6 Index: 59	<p>Displays the result of check of the linerization tabel.</p>

Expert → Communication → Transducer Block → TB Endress+Hauser Parameter	
Parameter name	Description
Tab xy value Display Slot: 6 Index: 60	"X-value" and "Y value" value pairs for Linearization curve.
Max. meas. press. Display Slot: 6 Index: 61	Displays the highest pressure value measured (peakhold indicator). You can reset this indicator by means of the "Reset peakhold" parameter.
Min. meas. press. Display Slot: 6 Index: 62	Displays the lowest pressure value measured (peakhold indicator). You can reset this indicator by means of the "Reset peakhold" parameter.
Empty calib. Entry Slot: 6 Index: 66	<p>Enter the output value for the lower calibration point (container empty). The unit defined in "Unit before lin." must be used.</p> <p></p> <ul style="list-style-type: none"> In the case of wet calibration, the level (container empty) must actually be available. The associated pressure is then automatically recorded by the device. In the case of dry calibration, the level (container empty) does not have to be available. The associated pressure has to be entered in the "Empty pressure" parameter for the "In pressure" level selection. The associated height has to be entered in the "Empty height" parameter for the "In height" level selection. <p>Factory setting: 0.0</p>
Full calib. Entry Slot: 6 Index: 67	<p>Enter the output value for the upper calibration point (container full). The unit defined in "Unit before lin." must be used.</p> <p></p> <ul style="list-style-type: none"> In the case of wet calibration, the level (container full) must actually be available. The associated pressure is then automatically recorded by the device. In the case of dry calibration, the level (container full) does not have to be available. The associated pressure has to be entered in the "Full pressure" parameter for the "In pressure" level selection. The associated height has to be entered in the "Full height" parameter for the "In height" level selection. <p>Factory setting: 100.0</p>
Pressure Empty/Full Display Slot: 6 Index: 68	Internal service parameter.
Calibration Empty/Full Display Slot: 6 Index: 69	Internal service parameter.
Max. Turndown Display Slot: 6 Index: 70	Internal service parameter

Expert → Communication → Transducer Block → TB Endress+Hauser Parameter	
Parameter name	Description
High-press. side Display Slot: 6 Index: 71	Determines, which pressure input corresponds to the high-pressure side. i This setting is only valid if the "SW/P2 High" DIP switch is switched off (see "Switch P1/P2 (163) (Deltabar)" parameter). Otherwise P2 corresponds to the high-pressure side in any case.
Reset peakhold Display Slot: 6 Index: 72	You can reset the "Min. meas. press." and "Max. meas. press." indicators with this parameter. Options: <ul style="list-style-type: none"> ▪ Abort ▪ Confirm Factory setting: Abort
Measuring mode Options Slot: 6 Index: 73	Select the measuring mode. The operating menu is structured differently depending on the measuring mode selected. ⚠ WARNING Changing the measuring mode affects the span (URV)! This situation can result in product overflow. ► If the measuring mode is changed, the span setting (URV) must be verified and, if necessary, reconfigured! Options: <ul style="list-style-type: none"> ▪ Pressure ▪ Level ▪ Flow (Deltabar) Factory setting: Pressure
Simulation mode Options Slot: 6 Index: 74	Switch on the simulation mode and select the simulation type. A simulation that is running is switched off if the measuring mode or Lin. mode (037) level mode is changed. Options: <ul style="list-style-type: none"> ▪ None ▪ Pressure, → see this table, "Sim. pressure" parameter ▪ Level, → see this table, "Sim. level" parameter ▪ Flow, → see this table, "Sim. flow (Deltabar M)" parameter ▪ Tank content, → see this table, "Sim. tank cont." parameter ▪ Alarm/warning, → see this table, "Sim. error no." parameter
<p>Cerabar M / Deltapilot M</p> <pre> graph TD subgraph Transducer_Block [Transducer Block] direction TB S[Sensor] --> ST[Sensor trim] ST --> PA[Position adjustment] PA --> D[Damping] D --> EP[Electr. Delta P] EP --> P[P] end SV[Simulation value Pressure] --> PA </pre>	

Expert → Communication → Transducer Block → TB Endress+Hauser Parameter	
Parameter name	Description
<div style="border: 1px solid black; padding: 5px; margin-bottom: 5px;">Pressure</div> <div style="text-align: center;">↓</div> <div style="text-align: center;">→</div>	<div style="border: 1px solid black; padding: 5px; margin-bottom: 5px;">Level</div> <div style="text-align: center;">←</div> <div style="border: 1px solid black; padding: 5px; margin-bottom: 5px;">Simulation value: - Level - Tank content</div> <div style="text-align: center;">↓</div> <div style="text-align: center;">PV PV = Primary Value</div> <div style="text-align: center;">↓</div> <div style="border: 1px solid black; padding: 5px; margin-bottom: 5px;">Analog Input Block</div>
Deltabar M	
<div style="border: 1px solid black; padding: 5px; margin-bottom: 5px;">Pressure</div> <div style="text-align: center;">↓</div> <div style="text-align: center;">→</div>	<div style="border: 1px solid black; padding: 5px; margin-bottom: 5px;">Sensor</div> <div style="text-align: center;">↓</div> <div style="border: 1px solid black; padding: 5px; margin-bottom: 5px;">Sensor trim</div> <div style="text-align: center;">↓</div> <div style="border: 1px solid black; padding: 5px; margin-bottom: 5px;">Position adjustment</div> <div style="text-align: center;">↓</div> <div style="text-align: center;">←</div> <div style="border: 1px solid black; padding: 5px; margin-bottom: 5px;">Damping</div> <div style="text-align: center;">↓</div> <div style="text-align: center;">P</div> <div style="text-align: center;">←</div> <div style="border: 1px solid black; padding: 5px; margin-bottom: 5px;">Level</div> <div style="text-align: center;">←</div> <div style="border: 1px solid black; padding: 5px; margin-bottom: 5px;">Flow</div> <div style="text-align: center;">←</div> <div style="border: 1px solid black; padding: 5px; margin-bottom: 5px;">Simulation value: - Level - Tank content</div> <div style="border: 1px solid black; padding: 5px; margin-bottom: 5px;">Simulation value: - Flow</div> <div style="text-align: center;">↓</div> <div style="text-align: center;">PV PV = Primary Value</div> <div style="text-align: center;">↓</div> <div style="border: 1px solid black; padding: 5px; margin-bottom: 5px;">Analog Input Block</div>
Sim. level Entry Slot: 6 Index: 76	Enter the simulation value. → See also "Simulation mode". Prerequisite: ■ "Measuring mode" = Level and "Simulation mode" = Level
Sim. tank cont. Entry Slot: 6 Index: 77	Enter the simulation value. → See also "Simulation mode". Prerequisite: ■ "Measuring mode" = Level, Lin. mode = "Activate table" and "Simulation mode" = Tank content.
Sim. flow (Deltabar M) Entry Slot: 6 Index: 78	Enter the simulation value. → See also "Simulation mode". Prerequisite: ■ "Measuring mode" = Flow and "Simulation mode" = Flow
Sim. pressure Entry Slot: 6 Index: 79	Enter the simulation value. → See also "Simulation mode". Prerequisite: ■ "Simulation mode" = Pressure Value when switched on: Current pressure measured value

Expert → Communication → Transducer Block → TB Endress+Hauser Parameter	
Parameter name	Description
Electr. delta P (Cerabar / Deltapilot) Options Slot: 6 Index: 80	This function activates the electr. delta P application with an external or constant value. Options: <ul style="list-style-type: none"> ▪ Off ▪ Ext. value 2 ▪ Constant Factory setting: Off
Pressure abs range Entry Slot: 6 Index: 81	Absolute measuring range of the sensor.
Lo trim measured Display Slot: 6 Index: 82	Displays the reference pressure present to be accepted for the lower calibration point.
Hi trim measured Display Slot: 6 Index: 83	Displays the reference pressure present to be accepted for the upper calibration point.
Pos. zero adjust (Deltabar M and gauge pressure sensors) Options Slot: 6 Index: 84	Position adjustment – the pressure difference between zero (set point) and the measured pressure doesn't need not be known. Example: <ul style="list-style-type: none"> – Measured value = 2.2 mbar (0.032 psi) – Correct the measured value via the "Pos. zero adjust (Deltabar M and gauge pressure sensors)" parameter with the "Confirm" option. This means that you are assigning the value 0.0 to the pressure present. – Measured value (after pos. zero adjust) = 0.0 mbar Options <ul style="list-style-type: none"> ▪ Confirm ▪ Abort Factory setting: Abort
Calib. offset (absolute pressure sensor) Entry Slot: 6 Index: 86	Position adjustment – the pressure difference between the set point and the measured pressure must be known. Example: <ul style="list-style-type: none"> – Measured value = 982.2 mbar (14.25 psi) – You correct the measured value with the value entered (e.g. 2.2 mbar (0.032 psi)) via the "Calib. Offset" parameter. This means that you are assigning the value 980.0 (14.21 psi) to the pressure present. – Measured value (after calib. offset) = 980.0 mbar (14.21 psi) Factory setting: 0.0
Damping Entry/Display Slot: 6 Index: 87	Enter damping time (time constant τ). The damping affects the speed at which the measured value reacts to changes in pressure.  The damping is only active if DIP switch 2 "damping τ " is in the ON position.

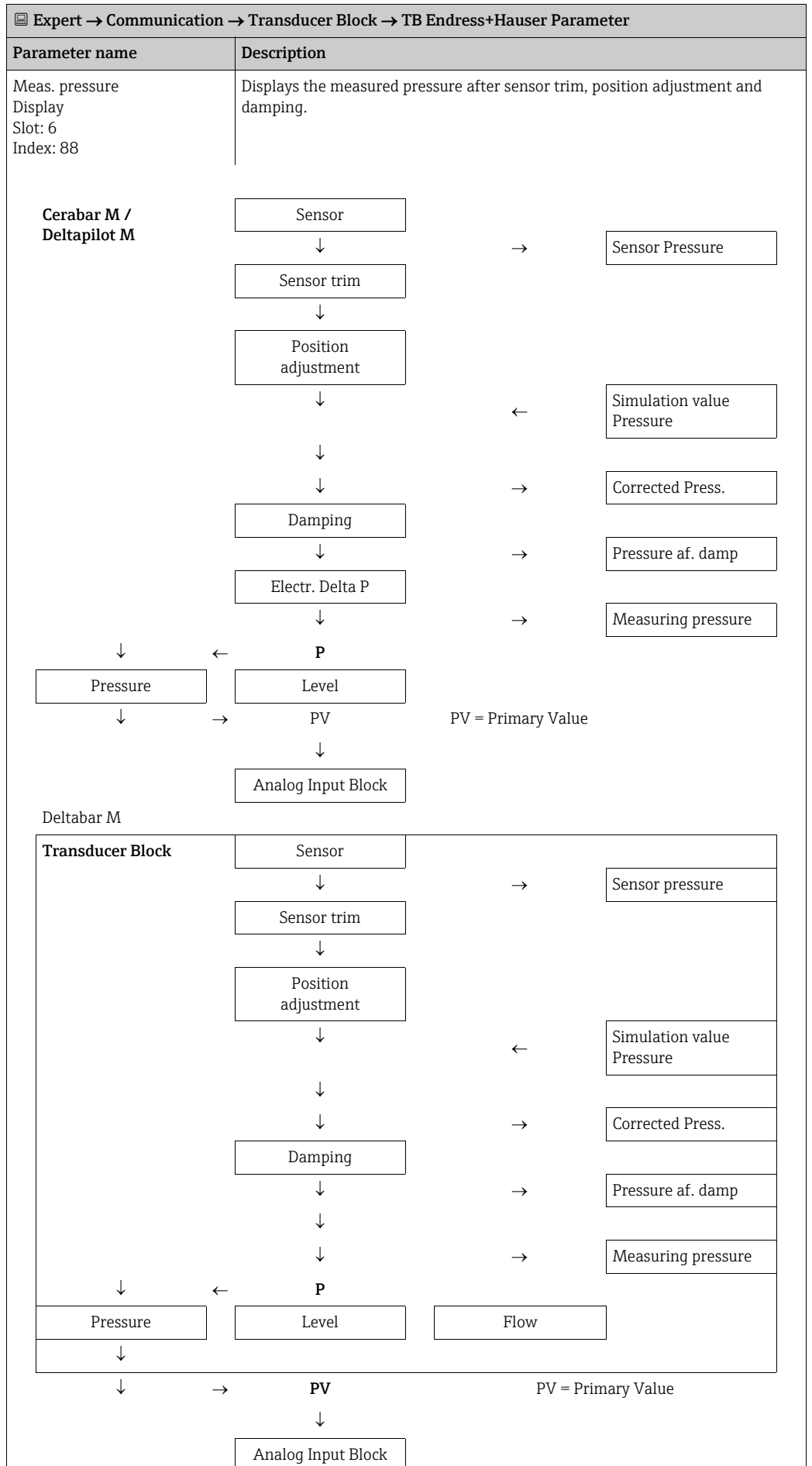

Expert → Communication → Transducer Block → TB Endress+Hauser Parameter	
Parameter name	Description
Unit before lin. Entry Slot: 6 Index: 89	Select the unit for the measured value display for the level before linearization.  The unit selected is only used to describe the measured value. This means that the measured value is not converted when a new output unit is selected. Example: <ul style="list-style-type: none"> ▪ Current measured value: 0.3 ft ▪ New output unit: m ▪ New measured value: 0.3 m Options <ul style="list-style-type: none"> ▪ % ▪ mm, cm, dm, m ▪ ft, in ▪ m³, in³ ▪ l, hl ▪ ft³ ▪ gal, lgal ▪ kg, t ▪ lb Factory setting: %
Calibration mode Options Slot: 6 Index: 90	Select the calibration mode. Options: <ul style="list-style-type: none"> ▪ Wet Wet calibration takes place by filling and emptying the container. In the case of two different levels, the level, volume, mass or percentage value entered is assigned to the pressure measured at this point in time ("Empty calib." and "Full calib." parameters). ▪ Dry Dry calibration is a theoretical calibration. For this calibration, you specify two pressure/level value pairs via the following parameters: "Empty calib.", "Empty pressure", "Full calib.", "Full pressure", "Empty height", "Full height". Factory setting: Wet
Height unit Options Slot: 6 Index: 91	Select the height unit. The measured pressure is converted to the selected height unit using the "Adjust density" parameter. Prerequisite "Level selection" = In height Options <ul style="list-style-type: none"> ▪ mm ▪ m ▪ in ▪ ft Factory setting: m
Density unit Display Slot: 6 Index: 92	Displays the density unit. The measured pressure is converted to a height using the "Height unit" and "Adjust density" parameters. Factory setting: <ul style="list-style-type: none"> ▪ g/cm³
Adjust density Entry Slot: 6 Index: 93	Enter the density of the medium. The measured pressure is converted to a height using the "Height unit" and "Adjust density" parameters. Factory setting: 1.0

Expert → Communication → Transducer Block → TB Endress+Hauser Parameter	
Parameter name	Description
Process Density Entry Slot: 6 Index: 94	Enter a new density value for density correction. The calibration was carried out with water as the medium, for example. Now the container is to be used for another medium with another density. The calibration is corrected appropriately by entering the new density value in the "Process Density" parameter.  If you change to dry calibration after completing a wet calibration using the "Calibration mode" parameter, the density for the "Adjust density" and "Process Density" parameters must be entered correctly before changing the calibration mode. Factory setting: 1.0
Meas. Level Display Slot: 6 Index: 95	Displays the height currently measured. The measured pressure is converted to a height using the Process density (035) parameter.
Empty height Entry/Display Slot: 6 Index: 96	Enter the height value for the lower calibration point (container empty). Select the unit via the "Height unit" parameter. Prerequisite: <ul style="list-style-type: none"> ■ "Level selection" = In height ■ "Calibration mode" = Dry -> entry ■ "Calibration mode" = Wet -> display Factory setting: 0.0
Full height Entry/Display Slot: 6 Index: 97	Enter the height value for the upper calibration point (container full). Select the unit via the "Height unit" parameter. Prerequisite: <ul style="list-style-type: none"> ■ "Level selection" = In height ■ "Calibration mode" = Dry -> entry ■ "Calibration mode" = Wet -> display Factory setting: Upper-range limit (URL) is converted to a height unit
Level before lin Display Slot: 6 Index: 98	Displays the level value before the linearization table.
Tank description Entry Slot: 6 Index: 101	Enter the tank description (max. 32 alphanumeric characters)

Expert → Communication → Transducer Block → TB Endress+Hauser Parameter	
Parameter name	Description
Lin. mode Options Slot: 6 Index: 102	Select the linearization mode. Options: <ul style="list-style-type: none"> ▪ Linear The level is output without being converted beforehand. "Level before lin" is output. ▪ Erase table: The existing linearization table is deleted. ▪ Manual entry (sets the table to the edit mode, an alarm is output): The value pairs of the table ("X-value" and "Y-value (041) (manual entry/in semi-auto. entry)") are entered manually. ▪ Semiautomatic entry (sets the table to the edit mode, an alarm is output): The container is emptied or filled in stages in this entry mode. The device records the level value automatically ("X-value"). The associated volume, mass or %-value is entered manually ("Y-value (041) (manual entry/in semi-auto. entry)"). ▪ Activate table The table entered is activated and checked with this option. The device shows the level after linearization. Factory setting: Linear
Unit after lin. Options Slot: 6 Index: 103	Select the unit of the level value after linearization (unit of the Y-value). Options: <ul style="list-style-type: none"> ▪ % ▪ cm, dm, m, mm ▪ hl ▪ in³, ft³, m³ ▪ l ▪ in, ft ▪ kg, t ▪ lb ▪ gal ▪ lgal Factory setting: %
Tank content Display Slot: 6 Index: 104	Displays the level value after linearization.
Empty calib. Entry Slot: 6 Index: 105	Enter the output value for the lower calibration point (container empty). The unit defined in "Unit before lin." must be used.  <ul style="list-style-type: none"> ▪ In the case of wet calibration, the level (container empty) must actually be available. The associated pressure is then automatically recorded by the device. ▪ In the case of dry calibration, the level (container empty) does not have to be available. The associated pressure has to be entered in the "Empty pressure" parameter for the "In pressure" level selection. The associated height has to be entered in the "Empty height" parameter for the "In height" level selection. Factory setting: 0.0

Expert → Communication → Transducer Block → TB Endress+Hauser Parameter	
Parameter name	Description
Full calib. Entry Slot: 6 Index: 106	Enter the output value for the upper calibration point (container full). The unit defined in "Unit before lin." must be used.  <ul style="list-style-type: none"> ▪ In the case of wet calibration, the level (container full) must actually be available. The associated pressure is then automatically recorded by the device. ▪ In the case of dry calibration, the level (container full) does not have to be available. The associated pressure has to be entered in the "Full pressure" parameter for the "In pressure" level selection. The associated height has to be entered in the "Full height" parameter for the "In height" level selection. <p>Factory setting: 100.0</p>
Tab xy value Display Slot: 6 Index: 107	Displays a pair of points of the linearization table.
Edit table Options Slot: 6 Index: 108	Select the function for entering the table. <p>Options:</p> <ul style="list-style-type: none"> ▪ Next point: enter the next point. ▪ Current point: stay on the current point to correct a mistake for example. ▪ Previous point: skip back to the previous point to correct a mistake for example. ▪ Insert point: insert an additional point (see example below). ▪ Delete point: delete the current point (see example below). <p>Example: Add a point - in this case between the 4th and 5th point for example</p> <ul style="list-style-type: none"> - Select point 5 via the "Line numb.:" parameter. - Select the "Insert point" option via the "Edit table" parameter. - Point 5 is displayed for the "Line numb.:" parameter. Enter new values for the "X-value" and "Y-value (041) (manual entry/in semi-auto. entry)" parameters. <p>Example: Delete a point - in this case the 5th point for example</p> <ul style="list-style-type: none"> - Select point 5 via the "Line numb.:" parameter. - Select the "Delete point" option via the "Edit table" parameter. - The 5th point is deleted. All of the subsequent points are moved up one number i.e. following deletion, the 6th point becomes Point 5. <p>Factory setting: Current point</p>
Lin tab index 01 Entry Slot: 6 Index: 109	First table point parameter for linearization via the Fieldcare module.
...	
Lin tab index 32 Entry Slot: 6 Index: 140	Last table point parameter for linearization via the Fieldcare module.
Ext. value 2 Display Slot: 6 Index: 141	Output value and status parameters of Analog Output 2.
Ext.val.2 unit Entry Slot: 6 Index: 142	Unit of the output value parameter of Analog Output 2.

Expert → Communication → Transducer Block → TB Endress+Hauser Parameter	
Parameter name	Description
Flow type Options Slot: 6 Index: 143	Select the flow type. Options: <ul style="list-style-type: none"> ▪ Volume operat. cond. (volume under operating conditions) ▪ Volume norm. cond. (norm volume under norm conditions in Europe: 1013.25 mbar and 273.15 K (0 °C)) ▪ Volume std. cond. (standard volume under standard conditions in the USA: 1013.25 mbar (14.7 psi) and 288.15 K (15 °C/59 °F)) ▪ Mass (mass under operating conditions) ▪ Flow in % Factory setting: Volume operat. conditions
Max. flow Entry Slot: 6 Index: 144	Enter maximum flow of primary element. See also layout sheet of primary element. The maximum flow is assigned to the maximum pressure which you enter via " Max. pressure flow (010) ".
Max. pressure flow Entry Slot: 6 Index: 145	Enter maximum pressure of primary element. → See layout sheet of primary element. This value is assigned to the maximum flow value (→ see " Max. flow (009) ").
Flow unit Entry Slot: 6 Index: 146	Unit of the set "flow type".
Mass flow unit Options Slot: 6 Index: 147	Select mass flow unit. When a new flow unit is selected, all flow-specific parameters are converted and displayed with the new unit within a flow type. When the flow type is changed, conversion is not possible. Prerequisite: <ul style="list-style-type: none"> ▪ "Flow type" = Mass Options: <ul style="list-style-type: none"> ▪ g/s, kg/s, kg/min, kg/h ▪ t/s, t/min, t/h, t/d ▪ oz/s, oz/min ▪ lb/s, lb/min, lb/h ▪ ton/s, ton/min, ton/h, ton/d Factory setting: kg/s
Std. flow unit Options Slot: 6 Index: 148	Select standard flow unit. When a new flow unit is selected, all flow-specific parameters are converted and displayed with the new unit within a flow type. When the flow type is changed, conversion is not possible. Prerequisite: <ul style="list-style-type: none"> ▪ "Flow type" = Volume std. conditions Options: <ul style="list-style-type: none"> ▪ Sm³/s, Sm³/min, Sm³/h, Sm³/d ▪ SCFS, SCFM, SCFH, SCFD Factory setting: Sm ³ /s

Expert → Communication → Transducer Block → TB Endress+Hauser Parameter	
Parameter name	Description
Norm. flow unit Options Slot: 6 Index: 149	Select norm flow unit. When a new flow unit is selected, all flow-specific parameters are converted and displayed with the new unit within a flow type Flow type. When the flow type is changed, conversion is not possible. Prerequisite: <ul style="list-style-type: none"> ▪ "Flow type" = Volume norm. cond. Options: <ul style="list-style-type: none"> ▪ Nm³/s, Nm³/min, Nm³/h, Nm³/d Factory setting: Nm ³ /s
Flow unit Options Slot: 6 Index: 150	Select volume flow unit. When a new flow unit is selected, all flow-specific parameters are converted and displayed with the new unit within a flow type Flow type. When the flow type is changed, conversion is not possible. Prerequisite: <ul style="list-style-type: none"> ▪ "Flow type" = Volume operat. cond. Options: <ul style="list-style-type: none"> ▪ dm³/s, dm³/min, dm³/h ▪ m³/s, m³/min, m³/h, m³/d ▪ l/s, l/min, l/h ▪ hl/s, hl/min, hl/d ▪ ft³/s, ft³/min, ft³/h, ft³/d ▪ ACFS, ACFM, ACFH, ACFD ▪ ozf/s, ozf/min ▪ gal/s, gal/min, gal/h, gal/d, Mgal/d ▪ Igal/s, Igal/min, Igal/h ▪ bbl/s, bbl/min, bbl/h, bbl/d Factory setting: m ³ /s
Flow Display Slot: 6 Index: 151	Displays the present flow value.
Totalizer 2 mode Options Slot: 6 Index: 153	Define the behavior of the totalizer. Options: <ul style="list-style-type: none"> ▪ Balanced: Integration of all measured flows (positive and negative) ▪ Pos. flow only: only positive flows are integrated. ▪ Neg. flow only: only negative flows are integrated. ▪ Hold: The totalizer is stopped and keeps its current value. Factory setting: Pos. flow only
Totalizer 2 Display Slot: 6 Index: 154	Displays the counter reading of totalizer 2. The Totalizer 2 overflow parameter displays the overflow. Example: The value 123456789 m ³ is indicated as follows: <ul style="list-style-type: none"> - Totalizer 1: 3456789 m³ - Totalizer 1 overflow: 12 E7 m³
Eng. unit totalizer 2 Options Slot: 6 Index: 155	Select the unit for totalizer 2. The Direct Access Code and the option list depends on the selected "Flow type": <ul style="list-style-type: none"> - (065): Flow. meas. type "Mass" - (066): Flow. meas. type "Gas norm. cond." - (067): Flow. meas. type "Gas. std. cond." - (068): Flow. meas. type "Volume process cond." Factory setting: m ³

Expert → Communication → Transducer Block → TB Endress+Hauser Parameter	
Parameter name	Description
Totalizer 2 Display Slot: 6 Index: 156	Displays the total flow value of totalizer 2. The Totalizer 2 overflow parameter displays the overflow. Example: The value 123456789 m ³ is indicated as follows: – Totalizer 1: 3456789 m ³ – Totalizer 1 overflow: 12 E7 m ³
Totalizer 2 overflow Display Slot: 6 Index: 157	Displays the overflow value of totalizer 2. → See also "Totalizer 2".
Eng. unit totalizer 2 Options Slot: 6 Index: 158, 159, 160, 161	Select the unit for totalizer 2. → See also UNIT_TOT (224). The Direct Access Code and the option list depends on the selected "Flow type": – (065): Flow. meas. type "Mass" – (066): Flow. meas. type "Gas norm. cond." – (067): Flow. meas. type "Gas. std. cond." – (068): Flow. meas. type "Volume process cond." Factory setting: m ³
Totalizer 1 Display Slot: 6 Index: 162	Displays the totalizer value.
Totalizer 1 overflow Display Slot: 6 Index: 163	Displays the overflow value of totalizer 1. → See also "Totalizer 1"
Total. 2 failsafe Options Slot: 6 Index: 164	Define the behavior of the totalizer 2 in the case of an error. Options: ▪ Actual value (It is integrated with the current flow value on.) ▪ Hold: The totalizer is stopped and keeps its current value. Factory setting: Actual value
Damping Entry/Display Slot: 6 Index: 165	Enter damping time (time constant τ). The damping affects the speed at which the measured value reacts to changes in pressure.  The damping is only active if DIP switch 2 "damping τ " is in the ON position.
Level selection Options Slot: 6 Index: 166	Select the method for calculating the level Options: ▪ In pressure If this option is selected, specify two pressure/level value pairs. The level value is displayed directly in the unit that you select via the "Unit before lin." parameter. ▪ In height If this option is selected, specify two height/level value pairs. From the measured pressure, the device first calculates the height using the density. This information is then used to calculate the level in the "Unit before lin." selected using the two value pairs specified. Factory setting: In pressure

Expert → Communication → Transducer Block → TB Endress+Hauser Parameter	
Parameter name	Description
High-press. side Selection/Display Slot: 6 Index: 167	Determines, which pressure input corresponds to the high-pressure side.  This setting is only valid if the "SW/P2 High" DIP switch is switched off (see "Switch P1/P2 (163) (Deltabar)" parameter). Otherwise P2 corresponds to the high-pressure side in any case.
Fixed ext. value (Cerabar / Deltapilot) Entry Slot: 6 Index: 168	Use this function to enter the constant value. The value refers to Electr. delta P (Cerabar / Deltapilot)" (→ 190). Factory setting: 0.0
Empty pressure Entry/Display Slot: 6 Index: 169	Enter the pressure value for the lower calibration point (container empty). → See also "Empty calib." Prerequisite <ul style="list-style-type: none"> ▪ "Level selection" = In pressure ▪ "Calibration mode" = Dry -> entry ▪ "Calibration mode" = Wet -> display Factory setting: 0.0
Full pressure Entry/Display Slot: 6 Index: 170	Enter the pressure value for the upper calibration point (container full). → See also "Full calib. (031)". Prerequisite <ul style="list-style-type: none"> ▪ "Level selection" = In pressure ▪ "Calibration mode" = Dry -> entry ▪ "Calibration mode" = Wet -> display Factory setting: Upper-range limit (URL) of the sensor
Pressure af. damp Display Slot: 6 Index: 171	Displays the measured pressure after sensor trim, position adjustment and damping. <div style="display: flex; align-items: center;"> <div style="margin-right: 20px;"> <p>Cerabar M / Deltapilot M</p> </div> </div>

Expert → Communication → Transducer Block → TB Endress+Hauser Parameter	
Parameter name	Description
<p>Deltabar M</p>	
<p>Calib. Offset Entry</p> <p>Slot: 6 Index: 172</p>	<p>Position adjustment – the pressure difference between the set point and the measured pressure must be known.</p> <p>Example:</p> <ul style="list-style-type: none"> – Measured value = 982.2 mbar (14.25 psi) – You correct the measured value with the value entered (e.g. 2.2 mbar (0.032 psi)) via the "Calib. Offset" parameter. This means that you are assigning the value 980.0 (14.21 psi) to the pressure present. – Measured value (after calib. offset) = 980.0 mbar (14.21 psi) <p>Factory setting: 0.0</p>
<p>Sensor temp. (Cerabar/Deltapilot) Display</p> <p>Slot: 6 Index: 173</p>	<p>Displays the temperature currently measured in the sensor. This can deviate from the process temperature.</p>
<p>X-value Display/Semiautomatic entry</p> <p>Slot: 6 Index: 174</p>	<p>If "Lin. mode" = "Semiautomatic", the level value is displayed and must be confirmed by entering the associated Y-value.</p>
<p>Sensor serial no. Display</p> <p>Slot: 6 Index: 175</p>	<p>Displays the serial number of the sensor (11 alphanumeric characters).</p>
<p>Totalizer 1 Display</p> <p>Slot: 6 Index: 176</p>	<p>Displays the totalizer value.</p>

Expert → Communication → Transducer Block → TB Endress+Hauser Parameter	
Parameter name	Description
PaTbRangeParameters Entry Slot: 6 Index: 177	This parameter is a structured parameter with transducer scaling information for the internal function of the upload/download module.
Eng. unit totalizer 1 Options Slot: 6 Index: 178, 179, 180, 181	Select unit for totalizer 1. Options Depending on the setting in the "Flow type" parameter (→ 196), this parameter offers a list of volume, norm volume, standard volume and mass units. When a new volume or mass unit is selected, totalizer-specific parameters are converted and displayed with the new unit within a unit group. When the flow mode is change, the totalizer value is not converted. The Direct Access Code depends on the selected "Flow type": – (058): Flow. meas. type "Mass" – (059): Flow. meas. type "Volume norm. cond." – (060): Flow. meas. type "Volume std. cond." – (061): Flow. meas. type "Volume process cond." Factory setting: m ³
TB View 1 Entry Slot: 6 Index: 182	Group of Transducer Block parameters that are read as one via a communication request. The TB View 1 comprises: <ul style="list-style-type: none"> ■ Static rev. no. ■ Block mode ■ Alarm summary ■ Primary value

9.6 Saving or duplicating device data

The device does not have a memory module. With an operating tool based on FDT technology (e.g. FieldCare), the following is, however, possible:

- Storage/recovery of configuration data
- Duplication of device parameters
- Transfer of all relevant parameters when replacing electronic inserts.

For further information, please refer to the Operating Instructions for the FieldCare operating program.

10 Maintenance

Deltabar M requires no maintenance.

For Cerabar M and Deltapilot M keep the pressure compensation and GORE-TEX® filter (1) free from contamination.

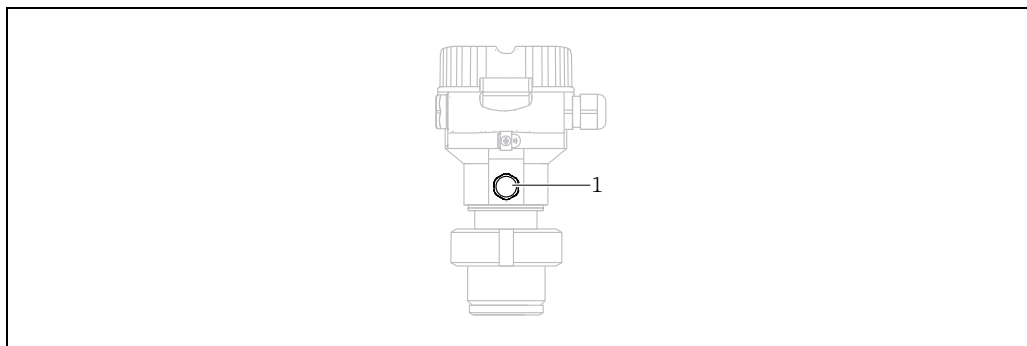

A0028502

10.1 Cleaning instructions

Endress+Hauser offer flushing rings as accessories to clean process isolating diaphragms without taking the transmitters out of the process.

For further information please contact your local Endress+Hauser Sales Center.

10.1.1 Cerabar M PMP55

We recommend you perform CIP (cleaning in place (hot water)) before SIP (sterilization in place (steam)) for pipe diaphragm seals. A frequent use of sterilization in place (SIP) will increase the stress on the process isolating diaphragm. Under unfavorable circumstances in the long term view we cannot exclude that a frequent temperature change could lead to a material fatigue of the process isolating diaphragm and possibly to a leakage.

10.2 Exterior cleaning

Please note the following points when cleaning the device:

- The cleaning agents used should not corrode the surface and the seals.
- Mechanical damage to the process isolating diaphragm, e.g. due to pointed objects, must be avoided.
- Observe the degree of protection of the device. See the nameplate if necessary (→ 9 ff).

11 Troubleshooting

11.1 Messages

The following table lists the messages that can occur. The Diagnostic code parameter shows the message with the highest priority. The device has four different status information codes according to NAMUR NE107:

- F = failure
- M (warning) = maintenance required
- C (warning) = function check
- S (warning) = out of specification (deviations from the permitted ambient or process conditions determined by the device with the self-monitoring function, or errors in the device itself indicate that the measuring uncertainty is greater than what would be expected under normal operating conditions).

Diagnostic code	Error message	Cause	Measure
0	No error	–	–
C411	Up-/Download	– Upload active.	Upload/download active, please wait
C484	Error simul.	– Fault state simulation is switched on, i.e. the device is not measuring at present.	End the simulation
C485	Measure simul.	– Simulation is switched on, i.e. the device is not measuring at present.	End the simulation
C824	Process pressure	– Overpressure or low pressure present. – Electromagnetic effects are greater than specifications in the technical data. This message normally only appears briefly.	1. Check the pressure value 2. Restart the device 3. Perform a reset
F002	Sens. unknown	– Sensor does not suit the device (electronic sensor nameplate).	Contact Endress+Hauser Service
F062	Sensor conn.	– Cable connection between sensor and main electronics disconnected. – Sensor defect. – Electromagnetic effects are greater than specifications in the technical data.	1. Check sensor cable 2. Replace electr. 3. Contact Endress+Hauser Service 4. Replace sensor (snap-on Version)
F081	Initialization	– Cable connection between sensor and main electronics disconnected. – Sensor defect. – Electromagnetic effects are greater than specifications in the technical data. This message normally only appears briefly.	1. Perform a reset 2. Check sensor cable 3. Contact Endress+Hauser Service
F083	Permanent mem.	– Sensor defect. – Electromagnetic effects are greater than specifications in the technical data. This message normally only appears briefly.	1. Restart the device 2. Contact Endress+Hauser Service
F140	Working range P	– Overpressure or low pressure present. – Electromagnetic effects are greater than specifications in the technical data. – Sensor defect.	1. Check the process pressure 2. Check the sensor range
F261	Electronics	– Main electronics defective. – Fault in the main electronics.	1. Restart the device 2. Replace electr.
F282	Data memory	– Fault in the main electronics. – Main electronics defective.	1. Restart the device 2. Replace electr.
F283	Permanent mem.	– Main electronics defective. – Electromagnetic effects are greater than specifications in the technical data. – The supply voltage is disconnected when writing. – An error occurred when writing.	1. Perform a reset 2. Replace electr.

Diagnostic code	Error message	Cause	Measure
F410	Up-/Download	<ul style="list-style-type: none"> - The file is defect. - During the download, the data are not correctly transmitted to the processor, e.g. because of open cable connections, spikes (ripple) on the supply voltage or electromagnetic effects. 	<ol style="list-style-type: none"> 1. Repeat download 2. Use another file 3. Perform a reset
F411	Up-/Download	<ul style="list-style-type: none"> - Download active. 	<ol style="list-style-type: none"> 1. Upload/download active, please wait 2. Restart, if download aborted
F437	Configuration	<ul style="list-style-type: none"> - The Profibus configuration is inconsistent. 	Adapt the characteristic type with the transmitter type in the Transducer Block Check the transmitter type Check the characterization Check the unit
F510	Linearization	<ul style="list-style-type: none"> - The linearization table is being edited. 	<ol style="list-style-type: none"> 1. Conclude entries 2. Select "linear"
F511	Linearization	<ul style="list-style-type: none"> - The linearization table consists of less than 2 points. 	<ol style="list-style-type: none"> 1. Table too small 2. Corr. table 3. Accept the table
F512	Linearization	<ul style="list-style-type: none"> - The linearization table is not monotonic increasing or decreasing. 	<ol style="list-style-type: none"> 1. Tab. not monotonic 2. Corr. table 3. Accept the table
F841	Sensor range	<ul style="list-style-type: none"> - Overpressure or low pressure present. - Sensor defect. 	<ol style="list-style-type: none"> 1. Check the pressure value 2. Contact Endress+Hauser Service
F882	Input signal	<ul style="list-style-type: none"> - External measured value is not received or displays a failure status. 	<ol style="list-style-type: none"> 1. Check the bus 2. Check source device 3. Check the setting
M002	Sens. unknown	<ul style="list-style-type: none"> - Sensor does not suit the device (electronic sensor nameplate). Device continues measuring. 	Contact Endress+Hauser Service
M283	Permanent mem.	<ul style="list-style-type: none"> - Cause as indicated for F283. - Correct measurement can continue as long as you do not need the peakhold indicator function. 	<ol style="list-style-type: none"> 1. Perform a reset 2. Replace electr.
M410	Up-/Download	<ul style="list-style-type: none"> - A value is exceeded or a parameter change was not accepted. - During the download, the data are not correctly transmitted to the processor, e.g. because of open cable connections, spikes (ripple) on the supply voltage or electromagnetic effects. - Electromagnetic effects are greater than specifications in the technical data. - The supply voltage is disconnected when writing. - An error occurred when writing. 	<ol style="list-style-type: none"> 1. Press the "Confirm" button to confirm 2. Repeat download 3. Use another file 4. Perform a reset
M431	Adjustment	<ul style="list-style-type: none"> - The pressure applied is outside the set measuring range (but within the sensor range). - The calibration carried out would result in the sensor nominal operating range being undershot or overshoot. 	<ol style="list-style-type: none"> 1. Check the measuring range 2. Check position adjustment 3. Check the setting
M434	Scaling	<ul style="list-style-type: none"> - Values for calibration (e.g. lower range value and upper range value) are too close together. - Lower range value and/or upper range value undershoot or overshoot the sensor range limits. - The sensor was replaced and the customer-specific configuration does not suit the sensor. - Unsuitable download carried out. 	<ol style="list-style-type: none"> 1. Check the measuring range 2. Check the setting 3. Contact Endress+Hauser Service
M438	Data record	<ul style="list-style-type: none"> - The supply voltage is disconnected when writing. - An error occurred when writing. 	<ol style="list-style-type: none"> 1. Check setting 2. Restart the device 3. Replace electr.
M515	Configuration Flow	<ul style="list-style-type: none"> - Max. flow out of nominal range of sensor 	<ol style="list-style-type: none"> 1. Recalibrate the device 2. Restart the device

Diagnostic code	Error message	Cause	Measure
M520	Ident. number	<ul style="list-style-type: none"> - The configured identification number is not supported by the device. - The user configuration data are not compatible with the set identification number. - The configuration data are not supported by the device or a requested feature is not enabled in the device (e.g. watchdog function, failsafe). - Unsuitable download carried out. 	Use the correct identification number
M882	Input signal	<ul style="list-style-type: none"> - External measured value displays a warning status. 	<ol style="list-style-type: none"> 1. Check the bus 2. Check source device 3. Check the setting
S110	Working range T	<ul style="list-style-type: none"> - Over temperature and low temperature present. - Electromagnetic effects are greater than specifications in the technical data. - Sensor defect. 	<ol style="list-style-type: none"> 1. Check proc. temp. 2. Check temperature range
S140	Working range P	<ul style="list-style-type: none"> - Overpressure or low pressure present. - Electromagnetic effects are greater than specifications in the technical data. - Sensor defect. 	<ol style="list-style-type: none"> 1. Check the process pressure 2. Check the sensor range
S822	Process temp.	<ul style="list-style-type: none"> - The temperature measured in the sensor is greater than the upper nominal temperature of the sensor. - The temperature measured in the sensor is lower than the lower nominal temperature of the sensor. 	<ol style="list-style-type: none"> 1. Check the temperature 2. Check the setting
S841	Sensor range	<ul style="list-style-type: none"> - Overpressure or low pressure present. - Sensor defect. 	<ol style="list-style-type: none"> 1. Check the pressure value 2. Contact Endress+Hauser Service

11.1.1 Onsite display error messages

If the device detects a defect in the onsite display during initialization, the following error messages can be displayed:

Message	Measure
Initialization, VU Electr. Defect A110	Exchange onsite display.
Initialization, VU Electr. Defect A114	
Initialization, VU Electr. Defect A281	
Initialization, VU Checksum Err. A110	
Initialization, VU Checksum Err. A112	
Initialization, VU Checksum Err. A171	

11.2 Response of outputs to errors

The device makes a distinction between the message types F (failure) and M, S, C (warning).
→ See the following table and Page 204, Section 11.1 "Messages".

Output	F (failure)	M, S, C (warning)
PROFIBUS	The process variable in question is transmitted with the status BAD ¹⁾ .	Device continues measuring. The process variable in question is transmitted with the status UNCERTAIN.
Onsite display	<ul style="list-style-type: none"> – The measured value and message are displayed alternately – Measured value display: F-symbol is permanently displayed. 	<ul style="list-style-type: none"> – The measured value and message are displayed alternately – Measured value display: M, S, or C-symbol flashes.

- 1) Process value: depends on the AI configuration
Totalizer 1: depends on the "Total. 1 failsafe" parameter

11.2.1 Analog Input Block

If the Analog Input Block receives an input value or simulation value with the status BAD, the Analog Input Block continues working with the failsafe mode defined by means of the "Fail safe mode" parameter.

The following options are available by means of the "Fail safe mode" parameter:

- Last valid out val.
The last valid value is used for further processing with the status UNCERTAIN.
- Fail safe value
The value specified by means of the "Failsafe default" parameter is used for further processing with the status UNCERTAIN.
- Status BAD
The current value is used for further processing with the status BAD.

Factory setting:

- Fail safe mode: Last valid out val.
- Failsafe default: 0



The BAD status is in anyway output if the "Out of service" (O/S) option was selected by means of the "Target mode" parameter.

11.2.2 Totalizer 1 Block

If the Totalizer 1 receives an input value from the transducer with the status BAD, the Totalizer 1 Block continues working with the failsafe mode defined by means of the "Total. 1 failsafe" parameter.

The following options are available by means of the "Total. 1 failsafe" parameter:

- Run
Totalizer 1 continues calculating with the input value, i.e. the input status is ignored. Depending on the "Cond. status diag", the value is output with the status "UNCERTAIN" in the "Classic status" mode or with the status "BAD" in the "Condensed status" mode.
- Memory
Totalizer 1 continues calculating with the last valid input value with the status "UNCERTAIN".
- Hold
Totalizer 1 is stopped if a BAD status occurs for the input value.

Factory setting:

Run



- The BAD status is in anyway output if the "Out of service" option was selected via the "Block mode/Target mode" parameter.
- If the error refers to a hardware failure, the "Totalizer 1" output retains the status "BAD" whatever is the failsafe mode.

11.3 Repair

The Endress+Hauser repair concept provides for measuring devices to have a modular design and that the customer can also carry out repairs (see → 209, Section 11.5 "Spare Parts").

- For certified devices, please see the "Repair of Ex-certified devices" section.
- For more information on service and spare parts, contact Endress+Hauser Service.
→ See www.endress.com/worldwide.

11.4 Repair of Ex-certified devices

WARNING

Limitation of electrical safety due to incorrect connection!

Risk of explosion!

When repairing Ex-certified devices, please note the following:

- Only specialist personnel or Endress+Hauser may repair certified devices.
- Relevant standards, national hazardous area regulations and safety instructions and certificates must be observed.
- Only genuine Endress+Hauser spare parts may be used.
- When ordering spare parts, please check the device designation on the nameplate. Identical parts may only be used as replacements.
- Electronic inserts or sensors already in use in a standard device may not be used as spare parts for a certified device.
- Carry out repairs according to the instructions. Following a repair, the device must fulfill the requirements of the specified individual tests.
- A certified device may only be converted to another certified device version by Endress+Hauser.
- All repairs and modifications must be documented.

11.5 Spare Parts

- Some replaceable measuring device components are identified by means of a spare part nameplate. This contains information about the spare part.
- All the spare parts for the measuring device along with the order code are listed in the W@M Device Viewer (www.endress.com/deviceviewer) and can be ordered. If available, users can also download the associated Installation Instructions.



Measuring device serial number:

- Located on the device and spare part nameplate.
- Can be read out via the "Serial number" parameter in the "Instrument info" submenu.

11.6 Return

The measuring device must be returned if repairs or a factory calibration are required, or if the wrong measuring device has been ordered or delivered. According to legal regulations, Endress+Hauser, as a ISO-certified company, is required to follow certain procedures when handling returned products that are in contact with process fluids.

To ensure swift, safe and professional device returns, please read the return procedures and conditions on the Endress+Hauser website at www.services.endress.com/return-material.

11.7 Disposal

When disposing, separate and recycle the device components based on the materials.

11.8 Software history

Device	Date	Software version	Software modifications	Operating Instructions
Cerabar M	01.2011	01.00.zz	Original software. Compatible with: – FieldCare from version 2.08.00	BA00383P/00/EN/01.11 71089566
				BA00383P/00/EN/02.11 71134594
				BA00383P/00/EN/03.11 71134883
				BA00383P/00/EN/04.12 71157183
				BA00383P/00/EN/05.12 71191307
				BA00383P/00/EN/06.14 71241503
				BA00383P/00/EN/07.14 71270332
				BA00383P/00/EN/08.16 71316872

Device	Date	Software version	Software modifications	Operating Instructions
Deltabar M	01.2011	01.00.zz	Original software. Compatible with: – FieldCare from version 2.08.00	BA00383P/00/EN/01.11 71089566
				BA00383P/00/EN/02.11 71134594
				BA00383P/00/EN/03.11 71134883
				BA00383P/00/EN/04.12 71157183
				BA00383P/00/EN/05.12 71191307
				BA00383P/00/EN/06.14 71241503
				BA00383P/00/EN/07.14 71270332
				BA00383P/00/EN/08.16 71316872

Device	Date	Software version	Software modifications	Operating Instructions
Deltapilot M	01.2011	01.00.zz	Original software. Compatible with: – FieldCare from version 2.08.00	BA00383P/00/EN/01.11 71089566
				BA00383P/00/EN/02.11 71134594
				BA00383P/00/EN/03.11 71134883
				BA00383P/00/EN/04.12 71157183
				BA00383P/00/EN/05.12 71191307
				BA00383P/00/EN/06.14 71241503
				BA00383P/00/EN/07.14 71270332
				BA00383P/00/EN/08.16 71316872

12 Technical data

For the technical data, please refer to the Technical Information for Cerabar M TI00436P / Deltabar M TI00434P / Deltapilot M TI00437P.

Index

A

Acyclic data exchange 72

B

Basic safety instructions 7

C

Cable specification 40–41

Cyclic data exchange 65

Cyclic data telegram 68

D

Data format 79

Designated use 7

Device addressing 60

Device display 50

Device identification 60

Diaphragm seals, installation instructions 18

Diaphragm seals, vacuum application 19

Differential pressure measurement, installation 29

Differential pressure measurement, preparatory steps 102

Display 50

E

Electrical connection 39

F

Factory setting 56

FieldCare 54

Flow measurement 104

Flow measurement, installation 25

Flow measurement, preparatory steps 105

G

General structure of the operating menu 48

GSD files 62

H

Hazardous area 8

I

Input data, structure 69

Installation instructions 33

Installation instructions for devices with diaphragm seals
18

Installation instructions for devices without diaphragm
seals 15

K

Keys, local, function 47, 52

Keys, local, pressure measuring mode 82

L

Language selection 85

Level measurement 17, 87

Level measurement, installation 27

Level measurement, preparatory steps 107

Linearization 97

Locking operation 48, 54

M

Measuring arrangement for pressure measurement . 16–
17

Measuring layout for flow measurement 26

Measuring layout for level measurement 27

Measuring layout for pressure measurement 29

Measuring mode selection 85

Mounting, suspension clamp 35

N

Nameplate 9

Number of devices 57

O

Operating elements, function 47, 52

Operating elements, position 46

Operating keys, position 46

Operational safety 7

Output data, structure 69

Overvoltage protection 42

P

Pipe mounting 22, 30, 36

Position adjustment, onsite 47

Position zero adjustment 86

Potential equalization 41

Product safety 8

PROFIBUS PA system architecture 57

R

Repair 208

Repair of Ex-certified devices 208

Reset 56

Returning devices 209

S

Scaling the OUT value 151

Scope of delivery 12

Separate housing, assembly and mounting 23, 37

Shielding 41

Slot/index tables 73

Software history 209

Spare Parts 209

Status code 69

Storage 13

Supply voltage 40

System integration 62

T

Temperature isolator, installation instructions 20

U

Unlocking operation 48, 54

W

Wall and pipe-mounting	30
Wall mounting	22, 36
Welding recommendation	24
Workplace safety	7



71316872

www.addresses.endress.com
