



Multi-functional precision thermometer, model CTR3000



Part of your business

Further languages can be found at www.wika.com.

© 2016 WIKA Alexander Wiegand SE & Co. KG

All rights reserved.

WIKA® is a registered trademark in various countries.

Prior to starting any work, read the operating instructions!

Keep for later use!

Contents

1.	General Information	6
1.1	Software license agreement.....	6
2.	Short overview	7
2.1	Overview	7
2.2	Description	7
2.3	Scope of delivery.....	7
3.	Safety	8
3.1	Explanation of symbols	8
3.2	Intended use	8
3.3	Improper use.....	10
3.4	Responsibility of the operator.....	10
3.5	Personnel qualification	10
3.6	Personal protective equipment.....	11
3.7	Labelling, safety marks.....	11
4.	Design and Function	12
4.1	Overview	12
4.2	Principles of measurement.....	13
4.2.1	PRT measurement.....	13
4.2.2	Thermocouple measurement	13
4.2.3	Thermocouple reference junction compensation	13
4.3	Front panel.....	14
4.3.1	Overview	14
4.3.2	Warm up time	14
4.3.3	Main screen; Home.....	15
4.3.4	Thermometer inputs.....	16
4.3.4.1	Resistance thermometers	16
4.3.4.2	Thermocouples.....	17
4.4	Application selection and parameter inputs	17
4.5	Rear panel.....	18
4.5.1	USB interface (standard).....	18
4.5.2	Ethernet interface	18
4.5.3	RS232 Communication interface card.....	18
4.5.4	Power input.....	18
4.5.5	Input channel expansion port (CTS Expansion, TC Expansion)	19
4.5.6	Name plate	19
4.6	Applications and their functions	20

- 4.6.1 Application <<Home>> 20
 - 4.6.1.1 Status bar 21
 - 4.6.1.2 Channel selection 21
 - 4.6.1.3 Freeze function 22
 - 4.6.1.4 Unit selection 22
 - 4.6.1.5 $\sqrt{2}$ current multiplier 23
 - 4.6.1.6 Probe selection 23
 - 4.6.1.7 Resolution “+/-“function 24
 - 4.6.1.8 Peak “clear” function 24
 - 4.6.1.9 Information bar 25
- 4.6.2 Application <<Settings>> 26
 - 4.6.2.1 Language 26
 - 4.6.2.2 Backlight-Off 26
 - 4.6.2.3 Brightness 27
 - 4.6.2.4 Time and Date 27
 - 4.6.2.5 Sound 28
 - 4.6.2.6 Data separator 28
 - 4.6.2.7 Factory reset 28
 - 4.6.2.8 Display – Average value 29
 - 4.6.2.9 Probes – Standard probe settings 29
 - 4.6.2.10 Probes – Alarm for probes 30
- 4.6.3 Application <<Probes>> 31
 - 4.6.3.1 New probe <<Resistance thermometers>> 32
 - 4.6.3.2 New probe <<thermocouples>> 35
 - 4.6.3.3 New probe <<thermistors>> 38
 - 4.6.3.4 Configure existing probes 40
 - 4.6.3.5 SMART probes 41
- 4.6.4 Application <<Scan>> 42
 - 4.6.4.1 Configuring a scan 42
 - 4.6.4.2 View 43
- 4.6.5 Application <<Logger>> 46
 - 4.6.5.1 General 47
 - 4.6.5.2 Log files 48
- 4.6.6 Application <<Remote>> 50
- 4.6.7 Application <<Info>> 51
- 4.6.8 Application <<Service>> 51
 - 4.6.8.1 Firmware update 51
 - 4.6.8.2 Program SMART probe 52
 - 4.6.8.3 WIKA service level 52
- 4.7 Download function 53**
 - 4.7.1 Log files 53

4.7.2	Screenshot	54
4.7.3	Measured Probes	54
4.7.4	SMART probes	55
4.7.5	All probes	55
4.7.6	Instrument details	56
4.8	Calibration services	56
4.9	Remote operation.....	56
5.	Transport, packaging and storage.....	57
5.1	Transport	57
5.2	Packaging and storage	57
6.	Commissioning, operation	58
7.	Faults.....	59
8.	Maintenance, cleaning and servicing	60
8.1	Maintenance	60
8.2	Cleaning	60
8.3	Recalibration	60
9.	Dismounting, return and disposal	61
9.1	Dismounting	61
9.2	Return.....	61
9.3	Disposal	62
10.	Specifications	63
11.	Technical information.....	64
11.1	Measurement uncertainty and traceability.....	64
11.2	International temperature scale.....	64
11.3	Measurement.....	65
11.3.1	Thermocouple	65
11.3.1.1	Introduction.....	65
11.3.1.2	Connection	66
11.3.2	Resistance thermometer.....	66
11.3.2.1	Linearization functions for resistance thermometers.....	66

Declarations of conformity can be found online at www.wika.com.

1. General Information

- The instrument described in the operating instructions has been designed and manufactured using state-of-the-art technology. All components are subject to stringent quality and environmental criteria during production. Our management systems are certified to ISO 9001 and ISO 14001.
- These operating instructions contain important information on handling the multi-functional precision thermometer CTR3000. Working safely requires that all safety instructions and work instructions are observed.
- Observe the relevant local accident prevention regulations and general safety regulations for the range of use of the multi-functional precision thermometer CTR3000.
- The operating instructions are part of the instrument and must be kept in the immediate vicinity of the multi-functional precision thermometer CTR3000 and readily accessible to skilled personnel at any time.
- Skilled personnel must have carefully read and understood the operating instructions, prior to beginning any work.
- The general terms and conditions, contained in the sales documentation, shall apply.
- Subject to technical modifications.
- Factory calibrations/DKD/DAkkS calibrations are carried out in accordance with international standards.

Further information:

- Internet address: www.wika.de / www.wika.com
- Relevant data sheet: CT 60.15
- Application consultant: Tel.: +49 9372 132-0
Fax: +49 9372 132-406
info@wika.de

Abbreviations, definitions

(S)PRT/RTD	Resistance thermometer
TC	Thermocouple

1.1 Software license agreement

The software included in this product contains copyrighted software that is licensed under the GPL/LGPL. A copy of the license texts can be found at the end of this document. You may obtain the complete Corresponding Source code from us for a period of three years after our last shipment of this product and/or spare parts therefor, which will be no earlier than 01/01/2030, for a fee of 10€. Please write an e-mail to CTServiceTeam@wika.com and write „Corresponding Source for CTR3000“ in the subject line. This offer is valid to anyone in receipt of this information.

WARNING! Installing modified versions of open source software components on the product will result in the loss of warranty. Also support service and software updates will be refused. Make sure to follow the safety precautions in the user manual. Improper access to the instrument is likely to result in its damaging.

2. Short overview

2.1 Overview



- ❶ Input for resistance thermometers or thermistors (5-DIN plug)
- ❷ Input for thermocouples (standard miniature plug)
- ❸ User interface, touchscreen
- ❹ Front end USB: Upload and download function
- ❺ Power on/off

2.2 Description

The model CTR3000 precision thermometer provides a complete measurement and control interface for users wishing to make high-accuracy temperature measurements or calibrate thermometers. It supports a wide range of thermometer types including 25 Ω SPRTs, 100 Ω PRTs, thermistors and thermocouples.

The CTR3000 is a high-accuracy instrument designed for laboratory and industrial temperature measurement and calibration applications.

2.3 Scope of delivery

- Model CTR3000 multi-functional precision thermometer incl. power cord
- Choice of model CTP5000/CTP9000 temperature probes, when ordered

3. Safety

EN

3.1 Explanation of symbols



DANGER!

... indicates a directly dangerous situation resulting in serious injury or death, if not avoided.



WARNING!

... indicates a potentially dangerous situation that can result in serious injury or death, if not avoided.



CAUTION!

... indicates a potentially dangerous situation that can result in light injuries or damage to property or the environment, if not avoided.

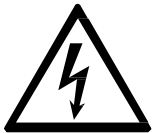

DANGER!

... identifies hazards caused by electrical power. Should the safety instructions not be observed, there is a risk of serious or fatal injury.



Information

... points out useful tips, recommendations and information for efficient and trouble-free operation.

3.2 Intended use

Application

The model CTR3000 precision thermometer provides a complete measurement and control interface for users wishing to make high-accuracy temperature measurements or calibrate thermometers. It supports a wide range of thermometer types including 25 Ω SPRTs, 100 Ω PRTs, thermistors and thermocouples.

The CTR3000 is a high-accuracy instrument designed for laboratory and industrial temperature measurement and calibration applications intended to be used in a basic electromagnetic environment.

Functionality

The instrument will operate with all 3- and 4-wire (S)PRTs (25 Ω , 100 Ω) platinum resistance thermometers as well as most standard international thermocouple types and NTC thermistors. The following temperature measurement units are selectable: $^{\circ}\text{C}$, $^{\circ}\text{F}$, K. Base measuring units mV and Ω are also displayed. The temperature values will be calculated through common conversion of the base measurement.

Due to the wide range of this instrument it makes individual instruments needless and makes the calibration cost-effective.

Features included:

- Dual capability for both thermocouple and resistance thermometer measurements
- Input channels can be expanded up to 44
- Large graphic touchscreen for temperature measurement values as well as configuration settings and statistical results
- Logger and log-data transfer to USB stick or communication interface
- Scan function with a live screen and graph
- Communication interfaces available for automated monitoring and calibration applications

This instrument is not permitted to be used in hazardous areas!

The instrument has been designed and built solely for the intended use described here, and may only be used accordingly.

The technical specifications contained in these operating instructions must be observed. Improper handling or operation of the instrument outside of its technical specifications requires the instrument to be taken out of service immediately and inspected by an authorised WIKA service engineer.

Handle electronic precision measuring instruments with the required care (protect from humidity, impacts, strong magnetic fields, static electricity and extreme temperatures, do not insert any objects into the instrument or its openings). Plugs and sockets must be protected from contamination.

The manufacturer shall not be liable for claims of any type based on operation contrary to the intended use.

For indoor use only

Use only the delivered power supply STONTRONICS 3A-182WP06
Input of external Power supply: 100/240 V~, 50-60 Hz, 0.6 A

Don't connect lines within a building which are longer than 30 m, or leave the building (including lines of outdoor installations).

3.3 Improper use

EN



WARNING!

Injuries through improper use

Improper use of the instrument can lead to hazardous situations and injuries.

- ▶ Refrain from unauthorised modifications to the instrument.
- ▶ Do not use the instrument within hazardous areas.
- ▶ Do not use the instrument with abrasive or viscous media.

Any use beyond or different to the intended use is considered as improper use.

3.4 Responsibility of the operator

The CTR3000 multifunctional precision thermometer is a high accuracy instrument designed for laboratory and industrial temperature measurement and calibration applications.

The operator is therefore responsible for legal obligations regarding safety at work.

The safety instructions within these operating instructions, as well as the safety, accident prevention and environmental protection regulations for the application area must be maintained.

The operator is obliged to maintain the product label in a legible condition.

To ensure safe working on the instrument, the operating company must ensure

- that the operating personnel are regularly instructed in all topics regarding work safety, first aid and environmental protection and know the operating instructions and in particular, the safety instructions contained therein.
- that the instrument is suitable for the particular application in accordance with its intended use.
- that personal protective equipment is available.

3.5 Personnel qualification



WARNING!

Risk of injury should qualification be insufficient

Improper handling can result in considerable injury and damage to equipment.

- ▶ The activities described in these operating instructions may only be carried out by skilled personnel who have the qualifications described below.

Skilled personnel

Skilled personnel, authorised by the operator, are understood to be personnel who, based on their technical training, knowledge of measurement and control technology and on their experience and knowledge of country-specific regulations, current standards and directives, are capable of carrying out the work described and independently recognising potential hazards.

Special operating conditions require further appropriate knowledge, e.g. of aggressive media.

3.6 Personal protective equipment

The personal protective equipment is designed to protect the skilled personnel from hazards that could impair their safety or health during work. When carrying out the various tasks on and with the instrument, the skilled personnel must wear personal protective equipment.

Follow the instructions displayed in the work area regarding personal protective equipment!

3.7 Labelling, safety marks

Product label

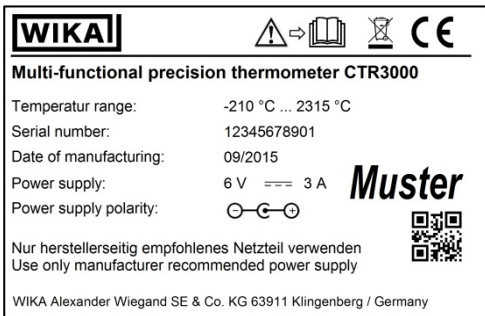

Symbols



Before mounting and commissioning the instrument, ensure you read the operating instructions!



CE, Communauté Européenne

Instruments bearing this mark comply with the relevant European directives.



This marking on the instruments indicates that they must not be disposed of in domestic waste. The disposal is carried out by return to the manufacturer or by the corresponding municipal authorities (see EU directive 2012/19/EU).

4. Design and Function

EN

4.1 Overview

The CTR3000 is a high accuracy instrument designed for laboratory and industrial temperature measurement and calibration applications.

Features include:

- unique dual capability for both thermocouple and resistance thermometer measurements;
- number of input channel can be expanded from four to forty-four channels;
- large graphic touchscreen for temperature measurement values as well as configuration settings and statistical results;
- advanced functions include differential measurement, programmable scanning routines, programmable timer, data logging, statistical reporting;
- USB and Ethernet (RS232 as an option) communication interfaces available for automated monitoring and calibration applications;

The CTR3000 will operate with all 3 and 4-wire Pt100 (100 Ohm) platinum resistance thermometers as well as most standard international thermocouple types. Temperature measurement units are selectable by front panel operation; °C, °F, K. Base measurement units mV, Ω are also displayed. Resistance accuracy is better than $\pm 2\text{m}\Omega$ equivalent to temperature measurement precision of $\pm 5\text{mK}$ for Pt100 thermometers.

Standard miniature sockets allow convenient connection for thermocouple inputs. Connection sockets incorporate integral temperature compensation sensors making high accuracy thermocouple measurement possible without the use of an external reference junction.

4.2 Principles of measurement

4.2.1 PRT measurement

The CTR3000 measures the voltage (V_t) developed across the unknown sensor resistance (R_t) and the voltage (V_s) across a stable internal reference resistance (R_s) connected in series and passing the same current. The voltages are in proportion to the resistances so the thermometer resistance is derived from: $R_t = R_s \times V_t / V_s$. This technique achieves immunity from slow moving time and temperature drift in the electronics as it is not affected by voltage measurement gain variations or current source fluctuations.

In the same way that AC resistance measurement eliminates thermal EMFs, switched DC achieves a similar advantage. Switched DC works by reversing the current flow on alternate measurement cycles and taking the average value, thereby cancelling any thermal EMF offsets from the measurement.

For PRTs, the relationship between resistance and temperature varies slightly from one PRT to another. Therefore, no matter how accurately the CTR3000 measures the PRT resistance, if the relationship between resistance and temperature for a particular PRT is not known, accurate temperature measurement is not possible.

The CTR3000 uses PRT calibration data to overcome this problem and calculates temperature from temperature conversion functions stored in internal memory. This method enables the CTR3000 accurately to convert resistance to temperature, uniquely for each PRT used. It is very important therefore that a PRT is used on the correct and properly configured input channel.

4.2.2 Thermocouple measurement

As well as the PRT resistance measurement facility the CTR3000 also functions as a precision millivolt-meter. Designed for high accuracy measurement over the EMF voltage range of all standard base and precious metal thermocouples, the CTR3000 achieves a basic voltage accuracy of better than $\pm 0,004\% + 2\ \mu\text{V}$ over the full measurement range.

Thermocouple EMFs are converted to temperature using the EN60584 linearization functions.

The voltage input connection is specially designed to minimise the thermal gradient between the terminals. This is particularly important when the internal reference junction compensation is used, as any temperature difference at the connection junction will influence the measurement result.

4.2.3 Thermocouple reference junction compensation

The electrical connection between the thermocouple element and the CTR3000 input connector is often referred to as the internal reference junction. All standard thermocouple reference functions are defined relative to 0°C . To eliminate the physical need to reproduce this temperature inside the CTR3000, the actual connection temperature is accurately measured with an internal PRT. This temperature is converted to an equivalent EMF and added to the actual thermocouple voltage measurement, thereby correcting for the connection temperature.

For high precision thermocouple measurement applications, i.e. calibration, an external reference junction may be used. Using an external reference junction eliminates the uncertainties associated with reference junction compensation.

4.3 Front panel

4.3.1 Overview

EN



- ① Input for resistance thermometers or thermistors (5-DIN plug)
- ② Input for thermocouples (standard miniature plug)
- ③ User interface, touchscreen
- ④ Front end USB: Upload and download function
- ⑤ Power on/off

4.3.2 Warm up time

It is recommended that the CTR3000 be warmed up before use to stabilize the environmentally controlled components. This will ensure the best performance to the specifications. We recommend a warm up time of 1 hour for full accuracy specifications.¹

¹ The internal cold junction compensation needs up to 2 hours for performing best.

4.3.3 Main screen; Home



- | | | | |
|----|---|----|---|
| 1 | Home application | 13 | Freeze the display; function key |
| 2 | General settings | 14 | Root 2 for sensor current PRT; function key* |
| 3 | Probe settings | 15 | Current displaying of average, stability and number of measurements |
| 4 | Scan settings | 16 | Peak displaying |
| 5 | Logger settings | 17 | Minus decimal place |
| 6 | Remote settings | 18 | Measured value in the base unit according to probe, e.g. Ω for Pt100 and mV for TC (displays °C, if the base unit is selected using button 9) |
| 7 | Info display | 19 | Current measured value** |
| 8 | Service settings | 20 | Selected channel; shortcut |
| 9 | Unit; shortcut | 21 | Current application name |
| 10 | Plus decimal place | | |
| 11 | Clear the peak values (min, max measured since starting the instrument) | | |
| 12 | Selected probe (standard or custom); shortcut | | |

* Selecting $\sqrt{2}$ current multiplier

This option increases current through the probes by $\sqrt{2}$ (double-power), to determine any probe self-heating. The best method of using this option is first to let the sensor reach a steady temperature and note the value. It may take some time to stabilise. Note the value down.

Press √2 the probe will increase the heating effect on the probe, and the value displayed will represent the temperature due to the increased current. When the reading has stabilised, note the temperature and calculate the temperature change.

** The selected input channel is interrogated before each measurement cycle, and when enabled, SMART probes are identified by 'SMART' appearing as (S) beside the field 14. Open circuit thermometer input channels will display nothing, the symbol "OL" displays that the measurement value is out of range.

4.3.4 Thermometer inputs

4.3.4.1 Resistance thermometers

EN

The CTR3000 has two resistance thermometer and two thermocouple input channels, the input sockets are located on the instruments front panel.

PRTs are connected via the 5 pin DIN sockets. You may connect 2, 3, or 4 wire PRTs as shown below. Un-terminated platinum resistance thermometers may be connected through an optional adapter box which is available as an accessory, (CTA5000-ADAP5-Z).

Resistance thermometer connection (5-pin DIN connector)

Channel 1 and 2 (PRT1, PRT2)

View towards front panel connector

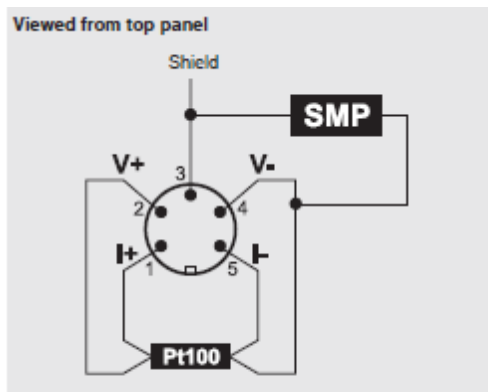
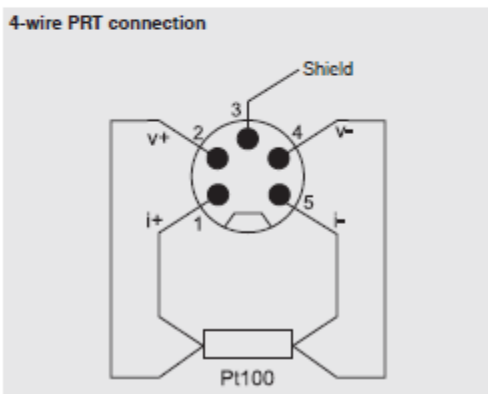
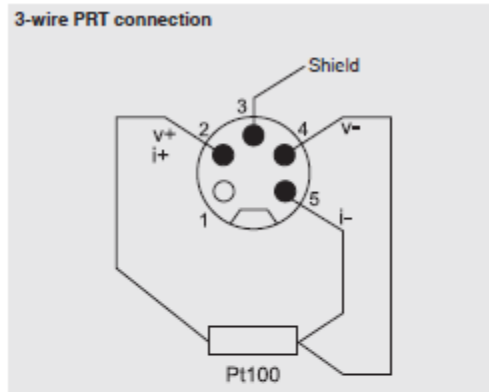
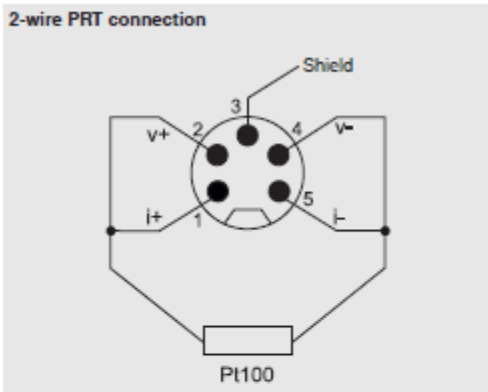

Options - with DIN plug or SMART plug

With the SMART connector on the probes, storing the data is needed only once - in the connector! The calibration data stays with the probe - permanently. It can even be used on another instrument without any further action.

The SMART connector saves time and reduces error. If there are existing calibrated or uncalibrated probes, no problem, CTR3000 automatically registers if a probe is SMART or normal.

4.3.4.2 Thermocouples

Thermocouples may be directly connected to the CTR3000 at the standard miniature sockets. These sockets are within a temperature compensated isothermal block which eliminates the need for an external ice point reference junction. However, the CTR3000 may also be used with an external ice point reference for high precision measurement and calibration work.

Thermocouple connection (miniature connector), channel 3 and 4 (TC3, TC4)

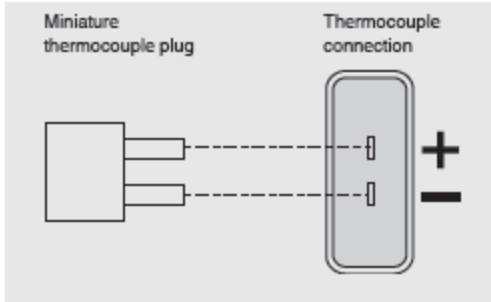

4.4 Application selection and parameter inputs

The application selection area on the right side of the screen is the area where settings, probes, logger, service and other apps can be chosen. As each App is chosen, related application parameters will appear on the left of the screen along with the name of the application, and a reduced size icon in the top title section. When a parameter is chosen, related selections, sliding scales or a data entry key pad will appear in the input area on the right where the application selection buttons were previously displayed. An example of each type of input is shown below. To return to the App selection menu, simply press the Menu button  below the input area.

Application title →



← Input title

Parameter inputs:

Related selections

Data entry key pad

Sliding scales



The selection will be presented on the right side of the function key for the input.

Confirm the values with  Min/max values will be indicated below the blue screen also QWERTZ keyboard available

14191761.01 03/2017 EN

4.5 Rear panel

EN

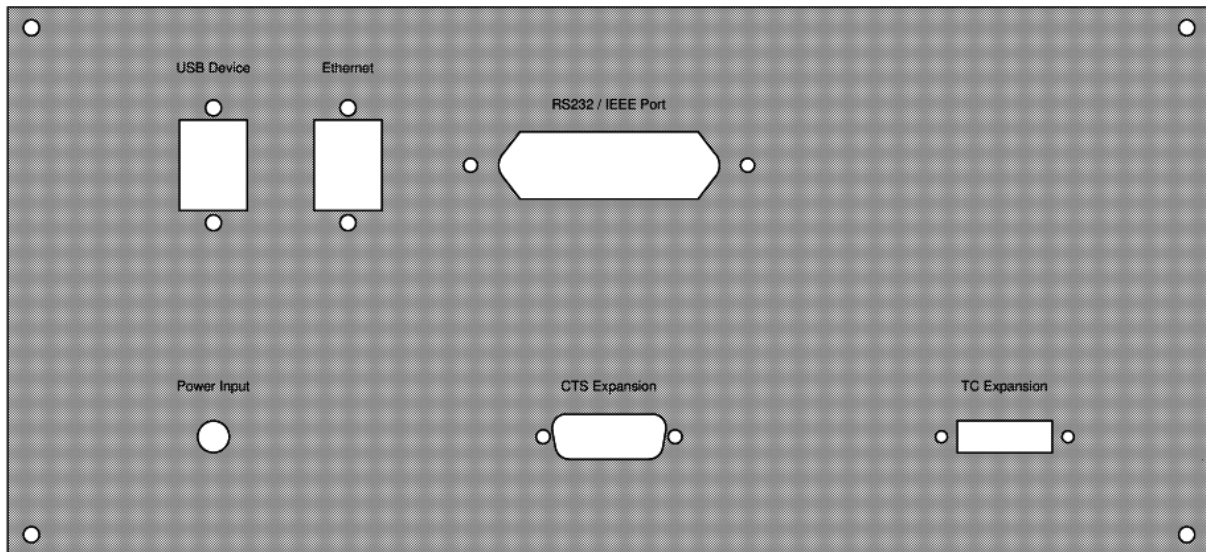

4.5.1 USB interface (standard)

The USB connector is fitted as standard. Communication requires the installation of the USB driver on a PC.

The instrument can be controlled through simple SCPI commands and can transmit SCPI result-data, which may be recorded using a simple terminal program.

Please refer to section 4.6.6 Application <<Remote>> for further details.

4.5.2 Ethernet interface

The Ethernet function allows the user to set the following by inputting a numeric value in each separate field:

- IP
- Netmask
- Gateway
- Port
- DHCP settings

Set the Ethernet communication parameters as described in Section 4.6.6 Application <<Remote>>.

4.5.3 RS232 Communication interface card

Optional RS232 communication interface card slot. A blanking plate is fitted if there is no communication interface card.

The CTR3000 may (optionally) be fitted with one of these interfaces. Operation is similar for all communication interfaces. Please refer to section 4.6.6 Application <<Remote>> for further details.

4.5.4 Power input

Use only the delivered power cable!

4.5.5 Input channel expansion port (CTS Expansion, TC Expansion)

Optional input channel expansion ports.

An expansion port connector is provided on the rear panel. The CTS expansion connector enables up to four CTS5000 switchboxes to be used to expand the number of input connections to provide up to 64 additional channels.

The universal switchbox CTS3000 will follow.

4.5.6 Name plate

Please see all details in chapter 3.7 Labelling, safety marks.

4.6 Applications and their functions

4.6.1 Application <<Home>>

EN

The Home App is the normal operation screen. This application is different from the others in that it is not used to setup the configuration but is used to monitor the temperature measurement values applied to this device.



- | | | | |
|----|---|----|---|
| 1 | Home application | 13 | Freeze the display; function key |
| 2 | General settings | 14 | Root 2 for sensor current PRT; function key* |
| 3 | Probe settings | 15 | Current displaying of average, stability and number of measurements |
| 4 | Scan settings | 16 | Peak displaying |
| 5 | Logger settings | 17 | Minus decimal place |
| 6 | Remote settings | 18 | Measured value in the base unit according to probe, e.g. Ω for Pt100 and mV for TC (displays °C, if the base unit is selected using button 9) |
| 7 | Info display | 19 | Current measured value** |
| 8 | Service settings | 20 | Selected channel; shortcut |
| 9 | Unit; shortcut | 22 | Current application name |
| 10 | Plus decimal place | | |
| 11 | Clear the peak values (min, max measured since starting the instrument) | | |
| 12 | Selected probe (standard or custom); shortcut | | |

4.6.1.1 Status bar



The status bar at the top end of the screen gives a description of the actual operating mode of the device.

Log = Logger is active
 SCAN = Scan is running
 REM = Interface is active

EN

4.6.1.2 Channel selection

By pressing function key 20 (refer to section 4.3.3 Main screen; Home) the menu for the channel selection opens on the right side. Back via the menu button on the bottom line.



1 = PRT 1
 2 = PRT 2
 3 = TC 3
 4 = TC 4

The selected channel will be indicated in the function key 20 like Chan "#selection#".

Mathematical functions

The CTR3000 can display several mathematical functions between two different channels (X, Y). The unit can be selected after the selection of the channel via function key 9 (refer to section 4.3.3 Main screen; Home). If the units for these two channels do not match (like PRT and TC), the value will be displayed in a temperature unit like °C, °F, or K.

- Input necessary for X and Y
- If you click on "X=" or "Y=" then a list of available channels opens on the right side
 - o Only numbers for channels selectable, which are connected
 - o If an invalid number is selected, an information dialog appears.



SMART probes take time to read their stored information. The SMART probe 'read on channel change' is disabled once a difference mode is selected. To change probes, select a single channel before reselecting a difference mode with SMART probes.

4.6.1.3 Freeze function

While clicking on the button “Freeze” (function key 13 please refer to section 4.3.3 Main screen; Home) the colour turns into orange and the display freezes/ holds.

EN

This function helps the user to read easier the values.



4.6.1.4 Unit selection

By pressing function key 9 (refer to section 4.3.3 Main screen; Home) the menu for the unit selection opens on the right side. Back via the menu button on the bottom line.



Sequence as shown left for all PRT channels.

Sequence for all TC channels like °C, °F, K and mV.

The selected unit will be indicated in the function key 9 like “#selection#”.

Beside the “Freeze” Button on the left side the corresponding value is displayed, e.g.:

- Pt100 and °C → then show Ohm
- TC and mV → then show °C

Calculation and units

1 °Celsius

$x \text{ °C} * 1,8 + 32 = y \text{ °Fahrenheit}$

$x \text{ °C} + 273,15 = y \text{ Kelvin}$

Temperature units

The temperature cannot be measured. The device measures Ohm or mV.

These electrical signals are calculated into temperature through the conversion of the probe.

4.6.1.5 $\sqrt{2}$ current multiplier

This option increases current through the probes by $\sqrt{2}$ (double-power), to determine any probe self-heating. The best method of using this option is first to let the sensor reach a steady temperature and note the value. It may take some time to stabilize.

Press the function key 14 (refer to section 4.3.3 Main screen; Home) and immediately the increased current through the probe will increase the heating effect on the probe, and the value displayed will represent the temperature change due to the increased current. When the reading has stabilized, note the temperature change. The result is the actual temperature with the effect of probe self-heating eliminated.

4.6.1.6 Probe selection

By pressing function key 12 (refer to section 4.3.3 Main screen; Home) the menu for the probe selection opens on the right side. Back via the menu button on the bottom line.



Standard probes see below.

Stored probes: List of all configured probes in the menu "Probes". Details see below.

The selected channel will be indicated in the function key 12 like "#selection#".

Standard probes for all PRT channels:

- Default 3w PRT (Pt100): Pt100, 3w, DIN conversion, internal 100 Ohm 3W-PT100
- Default 4w PRT (Pt100): Pt100, 4w, DIN conversion, internal 100 Ohm 4W-PT100
- Default SPRT (Pt25): Pt25, 4w, DIN conversion, internal 25 Ohm 4W-PT25
- Default Thermistor: 500 kOhm, no temperature conversion THERMISTOR

Standard probes for all TC channels:

- Default Thermocouple: TC K, internal reference cold junction

Stored probes:

- List of all configured probes in the menu "Probes". Details see below.
- "+" allows the user to configure a new probe and the user is directly linked to the menu "probes" (details in section 4.6.3 Application <<Probes).
- Sequence of the listed probes acc. ABC



A probe can only be assigned to one channel at a time, so it is not possible to e.g. assign stored probe PRT1 to channel 1 and 2 at the same time. This means that if a probe, which is currently assigned to a channel, is assigned to another channel. it is no longer assigned to the first channel. If no probe is explicitly assigned to a channel, the default probe for the channel type will be used. For PRT channels, this is 4W-PT100, for TC channels TC(K).

Easy access to probe settings:

Holding the button of the stored probes (in the home screen) >2s opens the probe menu for editing the selected probe. Please find more details how to edit/change probes in section 4.6.3 Application <<Probes>>.

EN



If a SMART probe is connected to a channel this function is invalid. Probe selection list will not show up, button is disabled. The SMART probe's identifier is shown in the button; the label shows "Probe (S)" to indicate the SMART probe.

4.6.1.7 Resolution "+/-" function

By pressing function key 17/10 (refer to section 4.3.3 Main screen; Home) the resolution will be lower/higher. Means the numbers of decimal places are configured.



By pressing „+“ a digit after the point/comma will be added, by pressing „-“ a digit after the point/comma will be deleted.

The buttons will turn inactive if the maximum or minimum setting is reached.

By changing the unit the numbers of the settable decimal places will change.

Minimum = 0 (no comma/point)

Maximum = 0.0001K/°C/°F / 0.00001Ω (PRT) / 0.00001mV (TC)

4.6.1.8 Peak "clear" function

The peak function (Min/Max) shows the maximum and minimum value for the actual recorded measurement in the unit displayed in the function key 9.



The peak field 16 (refer to section 4.3.3 Main screen; Home) shows in the first line Peak_Max and in the second line Peak_Min.

By pressing the „Clear“ function key 11 (refer to section 4.3.3 Main screen; Home) the values will be deleted and the values are refreshed.



Resolution fixed at 4 respectively 5 decimal places, only depending on unit selection.
Temperature selected → 4 places
Base value selected → 5 places
So only a change of the unit causes change of peak values.

4.6.1.9 Information bar

The information bar, field 15 (refer to section 4.3.3 Main screen; Home), displays relevant measurements which help you to have an easier calibration documentation.

Values

- Number of measurements: Setting in Settings >> Display >> Average value
- Average : Average value over the last xy values; displayed in the selected unit on the home screen
- Stability: shows the standard deviation
- Difference: displays the difference between the reference (first probe marked as reference) and the device under test (all other channels); displayed in the unit of the device under test (only shown in scan mode when the selected view is calibration, please refer to section 4.6.4 Application <<Scan>>)



Information bar has the same colour as the corresponding channel selection on the home screen (blue, green, red and orange). If channels are displayed in a list or no channel relevant information is displayed the information bar will be displayed in grey.

4.6.2 Application <<Settings>>

EN

General settings can be done in this menu in the following categories: general, display and probes. Pressing on the home screen the button “settings” guides the user into the sub-menu. This will open on the left side. For every entry settings can be done by clicking on the button. The settings menu opens on the right side.



4.6.2.1 Language

The language parameter provides a selection of different languages. Once a language is chosen all words within all menus will appear in the chosen language. This will not affect the decimal separator.



4.6.2.2 Backlight-Off

This setting will mean that the backlight will switch off, if no button is pressed for the set time. Options are displayed below.

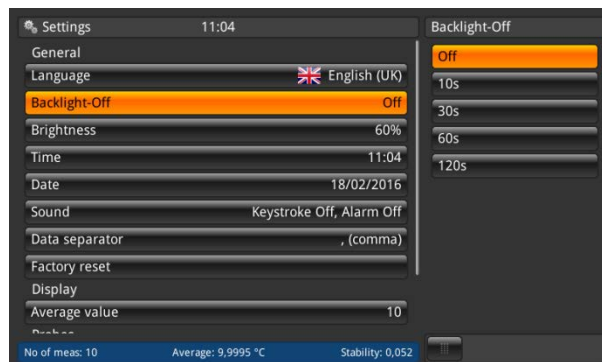

4.6.2.3 Brightness

The brightness setting provides a sliding scale to increment the screen brightness in all screens. Sliding your finger along the bar graph or touching anywhere in the bar graph will change the brightness of the screen. After the setting is made and your finger is removed from the screen the menu will show the brightness percent selected and revert back to the main settings menu.

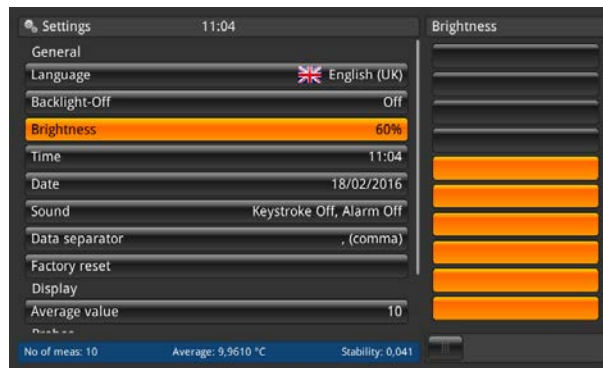

4.6.2.4 Time and Date

This setting ensured the correct time and date for your country. Different time and date formats are available.

Time changes on the main screen e.g. home view according to this setting. Date changes affect the stored calculation of the recalibration date.



Instrument has to restart after date or time change due to technical reasons. The instrument has no internal battery for the clock. This means that when the instrument remains powered off for several days, it loses the date and time setting.

4.6.2.5 Sound

The setting enables/disables the keystroke sound and the alarm sound.

EN

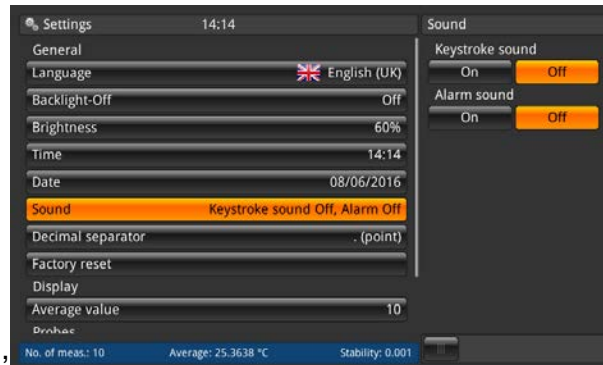

4.6.2.6 Data separator

The setting of the radix character (decimal mark) can be done from a dot (.) to a comma (,) or vice versa.

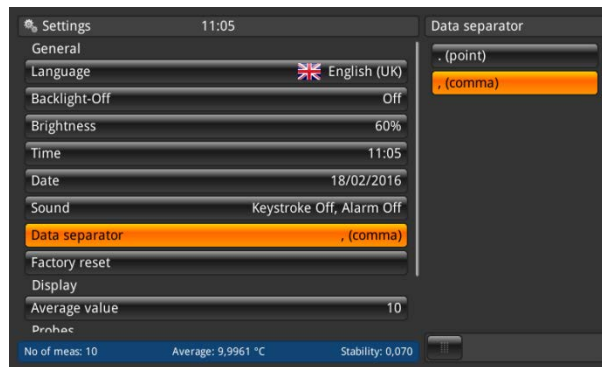

4.6.2.7 Factory reset

This function resets all values to their standard. Defined user probes won't be deleted. Factory reset overwrites the user calibration data with the factory calibration data.

The following dialog will follow by pressing the button <<Factory reset>> in which the user must obviously confirm that he resets the values to the standard ones.



4.6.2.8 Display – Average value

The average value is stated in the information bar on the home screen or other measuring screens. Definition: Average value = arithmetic average over the last measurements.

$$s = \sqrt{\frac{1}{n-1} \sum_{i=1}^n (x_i - \bar{x})^2}$$

The setting defines the “n” value for the formula above. When clicking on the button below <<sample count>> the numpad opens.

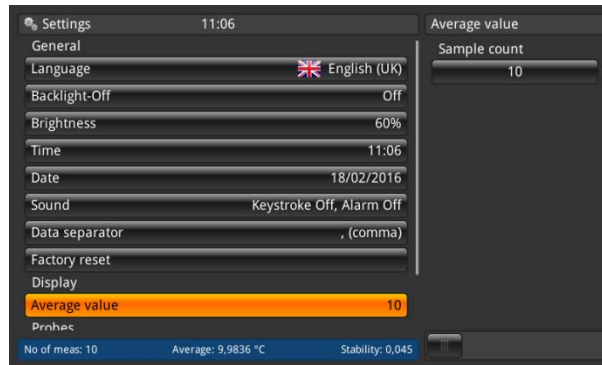

4.6.2.9 Probes – Standard probe settings

By clicking on the “Standard probe settings” button on the left side, the sub menu opens on the right. This function helps because these standard settings are pre-configured, if the user wants to store a new probe. Repeating types of thermometers can be easily pre-configured in this way.

For each section (standard conversion PRT, standard internal resistor, standard conversion TC and standard reference junction) one selection is necessary! For more details refer to chapter 4.6.3 Application <<Probes>>.

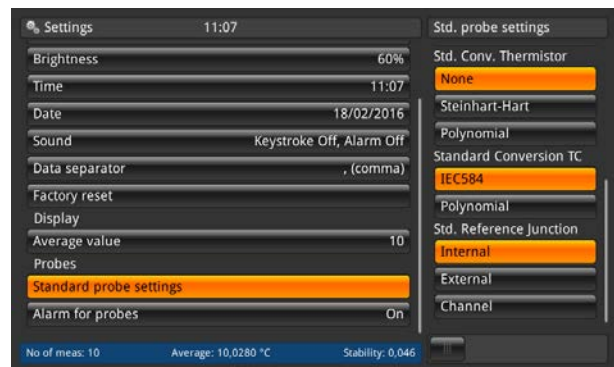
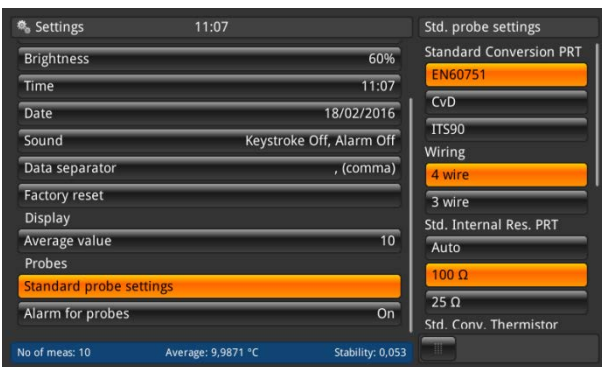

Standard settings are marked in orange.

4.6.2.10 Probes – Alarm for probes

By clicking on the “alarm for probes” button on the left side, the sub menu opens on the right. The option is between having an alarm for probes or not.

EN

If ON is clicked, then the measured temperature is compared with Tmax (set under probes). If $T_{max} < \text{measured temperature}$, then an error appears (exclamation mark left beside the function key 12).

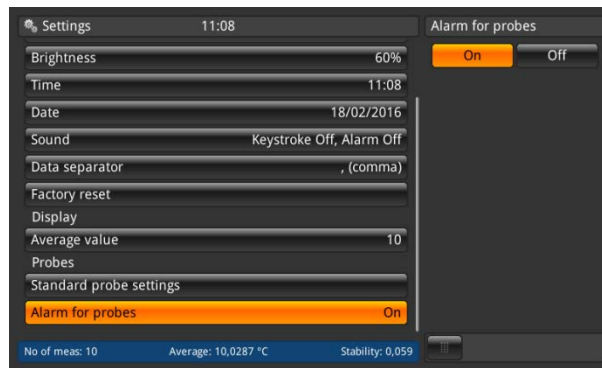

4.6.3 Application <<Probes>>

Higher accuracy measurements can be made using calibrated thermometers whose characteristics have been determined. Before being used, the thermometer and its calibration details must be entered into the CTR3000 in the application <<probes>> (press the button <<probes>> while being in the <<Home>> application) under <<new probe>>. The thermometer will then appear in the thermometer list below <<configure existing probes>> (refer to the following chapters).

Existing thermometers can be deleted via the recycle bin. These can also be find quick by searching the thermometers with the text search button (refer to section 4.6.3.4 Configure existing probes).



The maximum cable length of a temperature probe is 2 m.

4.6.3.1 New probe <<Resistance thermometers>>

To configure a new resistance thermometer click on the button <<resistance thermometer (PRT, SPRT)>> and the menu with all settings opens on the right. Once all settings are done the changes must be confirmed with <<Store>>.

EN

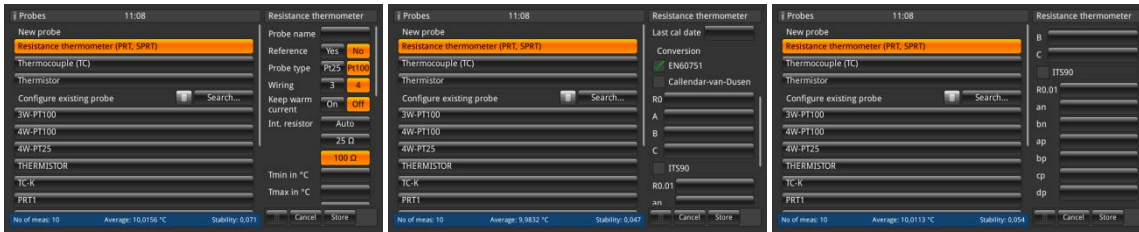

1. Probe name

Please enter a unique name (e.g. certificate number or serial number) for the new thermometer. This name is also shown later under the existing probes and for this name a search can be done. The input can be done via the qwertz keyboard.

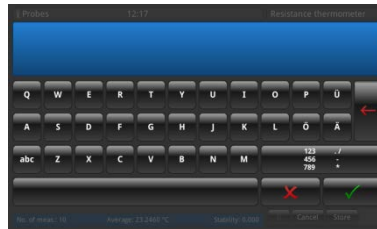

2. Reference

Please mark the thermometer as reference or not. This is important for the scan mode - view calibration because the difference between the first reference and the device under test will be calculated and displayed in the information bar.

3. Probe type

Is the thermometer a Pt25 or Pt100?

4. Wiring

Will be the connection a 3-wire or 4-wire?

5. Keep warm current

The device has the facility to drive deselected resistors or PRTs from a constant DC current source. This allows them to be kept at their normal working temperature, and so decrease settling time for each channel.

The keep warm current is user selectable as ON/OFF. If set on, the CTR3000 automatically adjusts the PRT current (from 1 mA for the 100 ohm reference) to 2 mA for the 25 ohm reference.

6. Int. resistor

The CTR3000 allows the choice between two internal reference resistors (25Ω and 100Ω) or the Auto-function. The 25 ohm resistor should only be used when a 25 ohm PRT (or lower) is used. Use the 100Ω reference resistor for all probes with R0 values above 25 Ω

The menu allows the use of Auto selection. The auto selection looks at the R0 value of the probe. If R0 is below 50 ohms, the 25 ohm reference is selected; any R0 value equal to or above 50 ohms will use the 100 ohm reference.

The CTR3000 automatically adjusts the PRT current (from 1 mA for the 100 ohm reference) to 2 mA for the 25 ohm reference.

7. Tmin

Probes may have a minimum temperature set for them (positive or negative). When the probe is assigned to a channel, the probe's temperature is checked against the set minimum and a range error (exclamation mark left beside the function key 12) issued if the minimum temperature is exceeded.

8. Tmax

Probes may have a maximum temperature set for them (positive or negative). When the probe is measured and active on a channel, the probe's temperature is checked against the set maximum and a range error (exclamation mark left beside the function key 12) issued if the maximum temperature is exceeded.

9. Last cal.

Please enter the last calibration date of the thermometer.

If the system date = last cal date + 1 year then a pop up is coming up which reminds that the probe is due to recalibration.



The recalibration cycle depends mainly on the thermal stress on the thermometer. The calibration time can only be estimated and is decided on by the user. Therefore check the calibration system at the triple point or freezing point of water on a regular basis (independent of the recalibration cycle). Recommendation is a calibration once a year.

10. Conversion

PRTs and SPRTs can be calibrated individually (resistance-temperature characteristics determined) in order to achieve low uncertainties. There are two algorithms used to represent the thermometer's characteristic (the Callendar Van Dusen equation and the ITS90 equations). The Callendar Van Dusen equation was developed first and was used as the primary conversion algorithm for all PRTs up until 1990. It is still applicable for PRTs and SPRT, although better uncertainty can be achieved by using the ITS90 equations (particularly important when using higher accuracy SPRTs).

In 1990, the International Temperature Scale was revised and a new set of equations were defined for converting the resistance of a PRT to temperature. These equations (commonly referred to as ITS90) comprise a nominal conversion that represent the average conversion characteristic and deviation functions that provide the adjustment for the characteristics of the individual thermometer. They are intended for use with high purity platinum and provide a better fit than can be achieved with the older Callendar Van Dusen equation. The ITS90 equations are sometimes also used with industrial PRTs made using the lower sensitivity 0.00385K^{-1} wire and can provide a small improvement in uncertainty compared with the Callendar Van Dusen equation.

a. *EN60751 as defined in the standard*

You can use the generic EN60751 conversion with PRTs that are made with a grade of wire that meets the requirements of the standard. The measurement uncertainty will depend on the class of thermometer and its temperature.

Standard coefficients:

$$R_0 = 100 \text{ Ohm}$$

$$A = 3.9083 \times 10^{-3} \text{ } ^\circ\text{C}^{-1}$$

$$B = -5.775 \times 10^{-7} \text{ } ^\circ\text{C}^{-2}$$

$$C = -4.183 \times 10^{-12} \text{ } ^\circ\text{C}^{-4}$$

b. *Callendar-van-Dusen like specified in the calibration certificate: R_0 , A , B and C*

This follows the formula:

$$R_t = R_0 [1 + At + Bt^2 + C(t - 100^\circ\text{C}) t^3]$$

$$(C = 0, \text{ if } t > 0 \text{ } ^\circ\text{C})$$

c. *ITS 90 as specified in the calibration certificate: $R_{0.01}$, a_n , b_n , a_p , b_p , c_p , d_p*



Make sure using the correct calibration parameters for the thermometer, since incorrect calibration parameters lead to erroneous results. The coefficients can be found in the calibration certificate while ordered a calculation.



If you order a CTR3000 with a resistance thermometer and a system calibration with calculation of the coefficients, the probe will be stored under the serial number and will be calibrated with the normal sensor current. No root 2.

4.6.3.2 New probe <<thermocouples>>

To configure a new thermocouple click on the button <<thermocouple (TC)>> and the menu with all settings opens on the right. Once all settings are done the changes must be confirmed with <<Store>>.

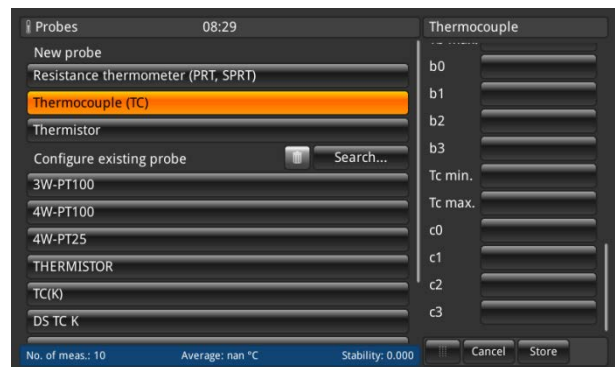
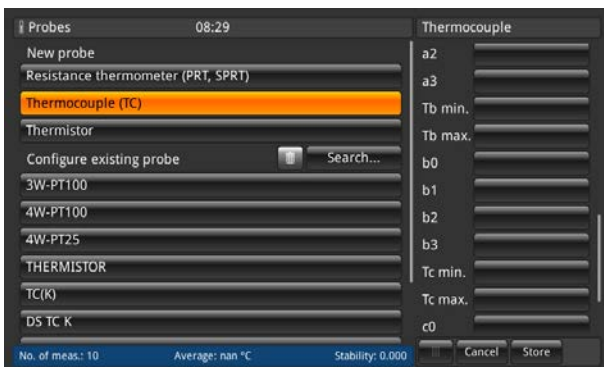
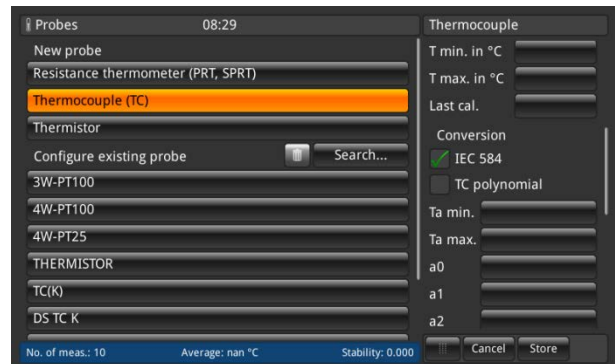
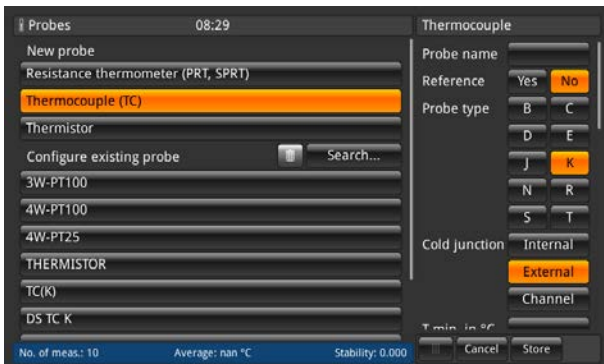

The CTR3000 can be used with any thermocouple (calibrated or uncalibrated) fitted with a standard miniature thermocouple connector. Connect your thermocouple to either of the miniature thermocouple connectors on the front panel.

1. Probe name
Please enter a unique name (e.g. certificate number or serial number) for the new thermometer. This name is also shown later under the existing probes and for this name a search can be done.
2. Reference
Please mark the thermometer as reference or not. This is important for the scan mode - view calibration because the difference between the first reference and the device under test will be calculated and displayed in the information bar.
3. Probe type
Is this thermocouple type B, E, J, K, N, R, S or T?

4. Cold junction

Three selections can be done: internal, external, channel

The selected issue turns into orange. If channel is selected then the num pad opens to define the channel. The number of the channel is right-aligned showed left to the button <<channel>>. Below the button <<channel>> the name of the probe is displayed.

a. *Internal*

Internal reference junction compensation using the internal temperature compensated copper isothermal junction. This is the default mode.

For direct temperature connection with no external reference junction. High accuracy measurement, requiring additional connection reference junctions.

b. *External*

No reference junction compensation applied to the measurement. All measurements are made with respect to 0°C. Used with an external ice point reference junction. Suitable for highest precision measurement.

c. *Channel*

External reference junction compensation using PRT measurement of reference junction. No measurement channels are lost as the reference channel PRT uses the corresponding input channel. For temperature controlled or ovenised reference junctions.

5. Tmin

Probes may have a minimum temperature set for them (positive or negative). When the probe is assigned to a channel, the probe's temperature is checked against the set minimum and a range error (exclamation mark left beside the function key 12) issued if the minimum temperature is exceed.

6. Tmax

Probes may have a maximum temperature set for them (positive or negative). When the probe is measured and active on a channel, the probe's temperature is checked against the set maximum and a range error (exclamation mark left beside the function key 12) issued if the maximum temperature is exceed.

7. Last cal.

Please enter the last calibration date of the thermometer.

If the system date = last cal date + 1 year then a pop up is coming up which reminds that the probe is due to recalibration.



The recalibration cycle depends mainly on the thermal stress on the thermometer. The calibration time can only be estimated and is decided on by the user. Therefore check the calibration system at the triple point or freezing point of water on a regular basis (independent of the recalibration cycle). Recommendation is a calibration once a year.

8. Conversion

The EMF-temperature characteristics of thermocouples are non-linear and the CTR3000 uses standard algorithms (from IEC584) to convert the measured EMF to a temperature. Thermocouples can be calibrated individually to achieve better measurement uncertainty. The calibration is presented as a deviation function polynomial.

- a. *IEC 584 as defined in the standard*
- b. *TC polynomial like specified in the calibration certificate*

$$\Delta V = C_0 + C_1 t + C_2 t^2 + C_3 t^3$$

where t is the temperature in °C and ΔV is the correction in millivolts.



Thermocouples are standardised, and the reference function for the most common thermocouple types is defined in IEC 584. The characteristic of individual thermocouples is usually close to the reference function. Therefore it is recommended to determine the deviation function from the reference function for the thermocouple under test in up to three temperature ranges, which must be indicated.



Make sure using the correct calibration parameters for the thermometer, since incorrect calibration parameters lead to erroneous results. The coefficients can be found in the calibration certificate while ordered a calculation.

4.6.3.3 New probe <<thermistors>>

To configure a new thermistor click on the button <<thermistor>> and the menu with all settings opens on the right. Once all settings are done the changes must be confirmed with <<Store>>.

EN

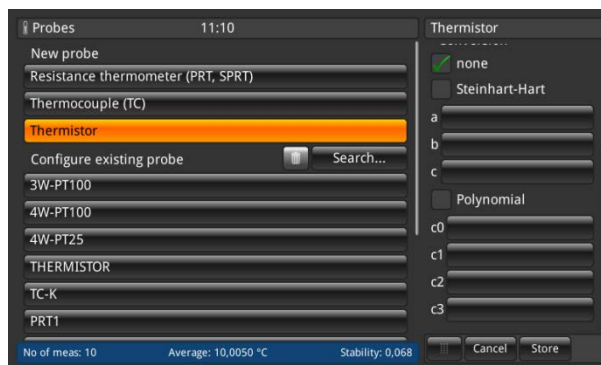
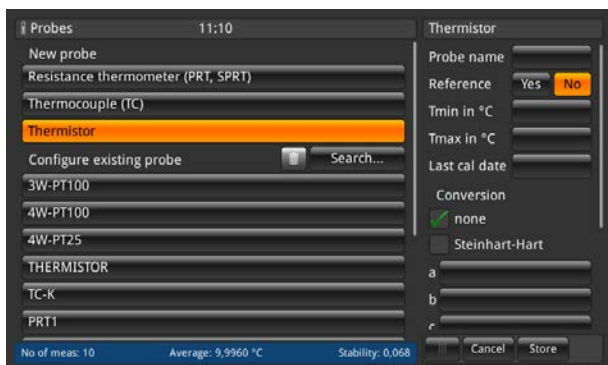

The CTR3000 can be used with thermistors. These are typically NTCs (negative temperature coefficient). Compared with PRTs/SPRTs, thermistors have a much higher resistance (typically measured in tens of k Ω), operate over a more limited temperature range (typically < 150°C) are highly non-linear (essentially logarithmic).

1. Probe name
Please enter a unique name (e.g. certificate number or serial number) for the new thermometer. This name is also shown later under the existing probes and for this name a search can be done.
2. Reference
Please mark the thermometer as reference or not. This is important for the scan mode - view calibration because the difference between the first reference and the device under test will be calculated and displayed in the information bar.
3. Tmin
Probes may have a minimum temperature set for them (positive or negative). When the probe is assigned to a channel, the probe's temperature is checked against the set minimum and a range error (exclamation mark left beside the function key 12) issued if the minimum temperature is exceeded.

4. Tmax

Probes may have a maximum temperature set for them (positive or negative). When the probe is measured and active on a channel, the probe's temperature is checked against the set maximum and a range error (exclamation mark left beside the function key 12) issued if the maximum temperature is exceeded.

5. Last cal.

Please enter the last calibration date of the thermometer.

If the system date = last cal date + 1 year then a pop up is coming up which reminds that the probe is due to recalibration.



The recalibration cycle depends mainly on the thermal stress on the thermometer. The calibration time can only be estimated and is decided on by the user. Therefore check the calibration system at the triple point or freezing point of water on a regular basis (independent of the recalibration cycle). Recommendation is a calibration once a year.

6. Conversion

a. *None, only the resistance is displayed*

b. *Steinhart-Hart like specified in the calibration certificate: a, b, and c*

The Steinhart-Hart equation is commonly used to convert the measured resistance to temperature.

$$\frac{1}{T} = a + b \cdot \ln(R) + c \cdot \ln^3(R)$$

c. *Polynomial like specified in the calibration certificate; c0, c1, c2 and c3*

$$\frac{1}{T} = c_0 + c_1 \cdot \ln(R) + c_2 \cdot \ln^2(R) + c_3 \cdot \ln^3(R)$$



Make sure using the correct calibration parameters for the thermometer, since incorrect calibration parameters lead to erroneous results. The coefficients can be found in the calibration certificate while ordered a calculation.

4.6.3.4 Configure existing probes

Under the menu section <<configure existing probe>> existing standard or user-defined probes can be changed or updated e.g. with new calibration data.

EN

As soon as you click on a probe on the left side, all parameters (detailed description in the chapters before) depending on the probe type (resistance thermometer, thermocouple or thermistor) will open on the right side.

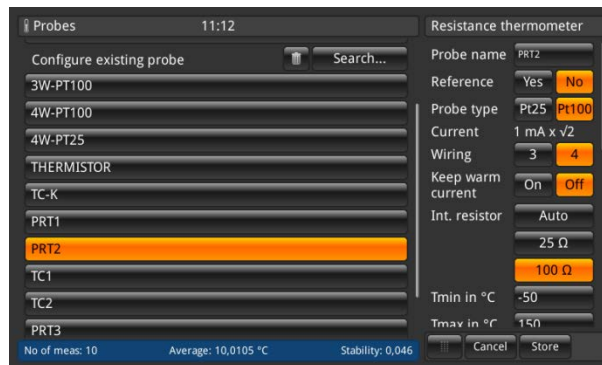

For the standard probes 3W-PT100, 4W-PT100, 4W-PT25, Thermistor and TC (K) only a few changes can be done. All other user defined probes can be configured as needed.

Delete

The recycle bin has been placed on the left side of the search field. This function deletes existing probes if they are selected in the list below. Every time the CTR3000 needs a confirmation for deleting probes.

Search

By clicking on the “search” button on the left side, the text pad opens on the right. There you are able to search after the probe name and the search button allows filtering the thermometer list, which is helpful to find thermometers within a large list. The character * can be used as wildcard to show all thermometers matching a name pattern. Found results are displayed then on the left side under the menu section <<configure existing probe>>.



To get all existing probes again displayed please press the button <<clear>> beside the filter.

4. Design and Function

Whenever you have changed the settings of your user-defined probe, you are able to restore the last configuration over the <<restore>> button at the end of the setting dialog. The CTR3000 wants to have a confirmation for restoring the last probe data. And then again the <<store>> button must be pressed as a confirmation.

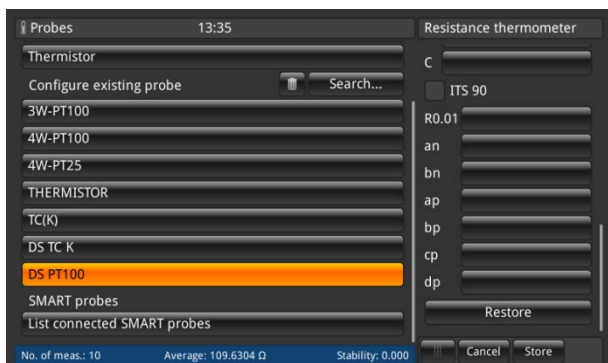

4.6.3.5 SMART probes

Under the menu section <<SMART probes>> you can disable SMART probes. When a SMART probe is disabled for a channel, the instrument uses the probe settings assigned to the channel.

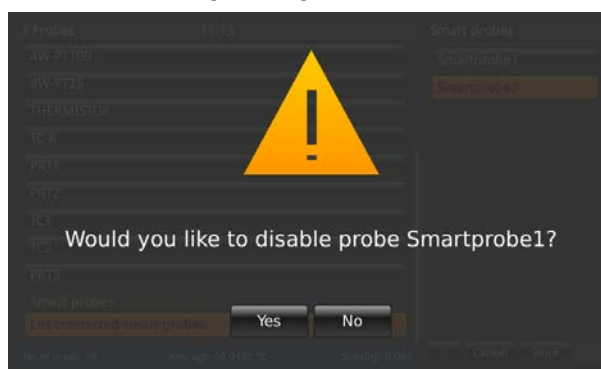
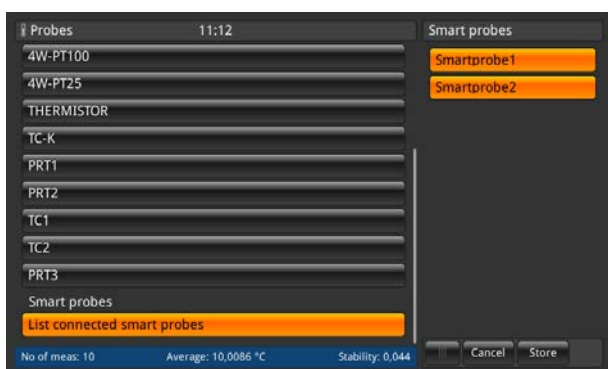

By clicking on the button << list connected SMART probes>> all connected SMART probes will be listed on the right side with their probe name. Every probe highlighted in orange is enabled/active and all others not. Clicking on the button of an active SMART probe means that this will be disabled. This setting has to be confirmed.



When SMART probe disabled for a channel, the instrument uses the probe settings assigned to the channel.



The scan of listed smart probes cannot be done while a scan is active.

4.6.4 Application <<Scan>>

EN

The application <<scan>> (via button <<scan>> in the right application menu) describes the function of this device that sequentially measures each channel and either temporarily shows the data on the display in the selected view. Scans are started manually by the user. To scan a channel, the CTR3000 sequentially cycles through the channels that are selected and makes measurements. Therefore this function allows the user to see more channels on the screen and to have a more or less automatic measurement of several channels.

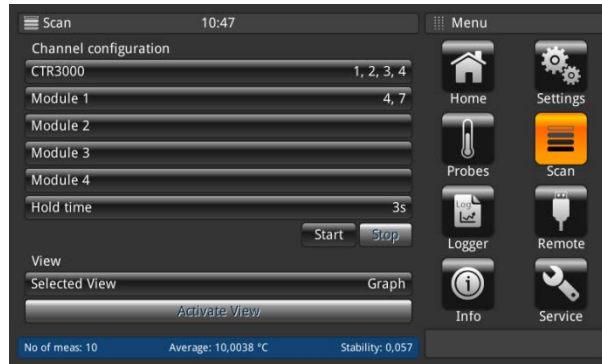

Modules are only available and selectable if these are connected.

4.6.4.1 Configuring a scan

Under the menu section <<channel configuration>> all or user-defined channels can be selected for the scan routine. Same procedure as for all other inputs: click on the left side and the input options will open on the right side.

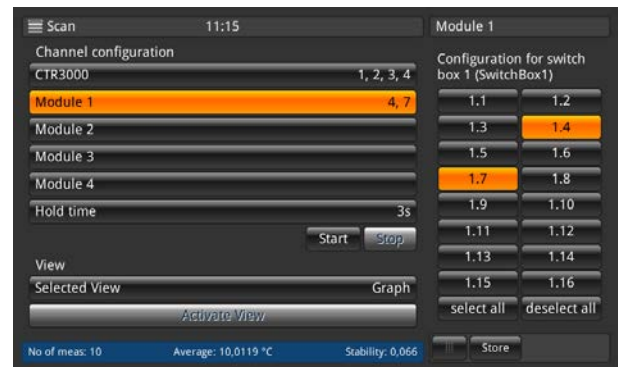
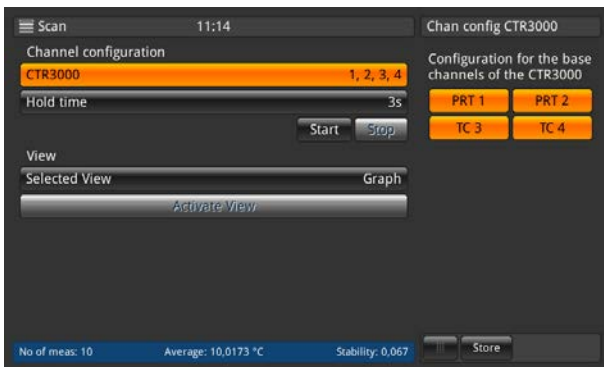

Select the channels you want to measure and then store the configuration by pressing the button <<store>>.

Select the channels you want to measure and then store the configuration by pressing the button <<store>>. By pressing the buttons <<select all>>/ <<deselect al>> the selection is easier by choosing all or nothing with one click.



Please ensure that for all configured resistance thermometers the keep warm current is <<ON>>. This allows quicker and more accurate measurements.

To set up a proper scan a hold time is needed. This value means how long the device stays at one channel before it switches to the next channel. The input of the value is via the numpad on the right side.

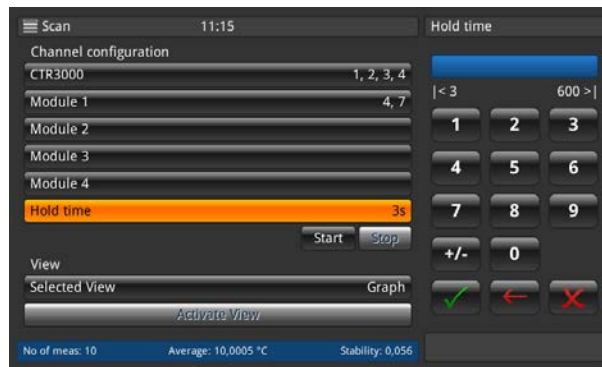

Valid values: 3 ...600 s

Means the quickest changing between the channels is 3s.

After all settings are done start the scan via the button <<start>>. Also in this menu the scan routine can be stopped, by pressing the button <<Stop>>. This button is active if the scan is already started. Vice versa the start button is only active if the scan is stopped.

4.6.4.2 View

By pressing the button <<selected view>> the sub menu opens on the right side. Scan or calibration view means that you see all channels you selected on the screens. According to the numbers of selected channels the view changes a little bit. Please see below for details. The graph view shows a graphic version with all selected channels.

To activate the selected view press the button <<Activate view>> (only active if the scan is started), this action guides to the selected scan view.

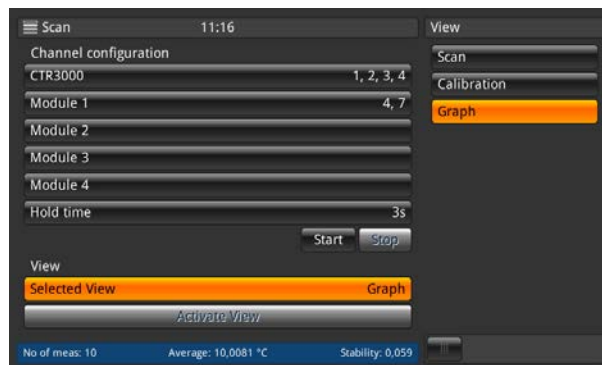

While changing from the scan application to the home application, please note that the scan is still active. This will be seen status and information bar.



Scan/Calibration view:

The difference between these two views is the information bar at the bottom of the device. In this a difference for the calibration view is displayed. The difference is the difference between the reference (probe marked as reference and listed first) and the device under test (all other channels), displayed in the unit of the device under test.

The function buttons and their behavior are known from the home application.



Scan/Calibration view: 2 channels selected

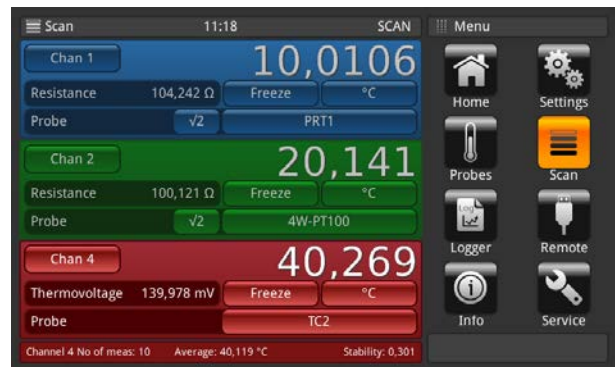

Scan/Calibration view: 3 channels selected



Scan/Calibration view: 3 channels selected

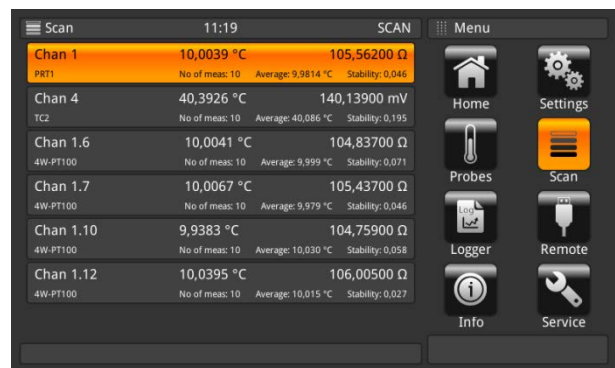

Scan/Calibration view: more than 4 channels selected



Pressing again the application <<scan>>, during seeing the different views of the scan, guides the user into the application <<scan>> menu, where all settings can be done and the scan can be stopped. Please refer to section 4.6.4.1 Configuring a scan.

Graph view:

With the graphic feature, channel measurement data for up to ten channels can be plotted and viewed on the display.

A probe must be assigned to a channel before on the home screen or via the function button in the graphic view itself. Also the unit must be chosen via the function button, which is indicated at the top of the y-axis. Only the same units can be displayed. E.g. Chan PRT1=Ohm, Chan 8.1=mV → displaying the graph in °C/°F/K is possible, but not in Ohm/mV. If the unit changes the y-axis is switched to auto scale.

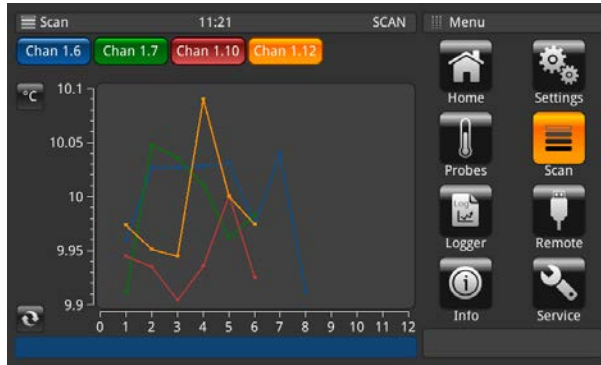

The x-axis shows the numbers of measurement. This is scrollable from the left to the right and vice versa. (Re-fresh button go to the actual measurement point in the graph) The y-axis shows the measuring values.



Pressing again the application <<scan>>, during seeing the different views of the scan, guides the user into the application <<scan>> menu, where all settings can be done and the scan can be stopped. Please refer to section Configuring a scan.

Adjustment of the graph



Via clicking on the button <<unit>>, in this case <<°C>>, a sub menu opens where the unit and the scale can be adjusted. Please take care that you set the right values for the customized scale in <<min>> and <<max>>, so that all measured values are displayed in the graph. The division will be chosen automatically. The closer min/max the better the resolution. Please confirm all inputs by pressing the button <<store>>.

4.6.5 Application <<Logger>>

EN

The application <<logger>> (via button <<logger>> in the right application menu) describes the function of this device that logs all data which is displayed on the <<Home>> or <<Scan>> Application. If a scan is active the actual channel will be logged. The different possible settings are explained in the following sections.

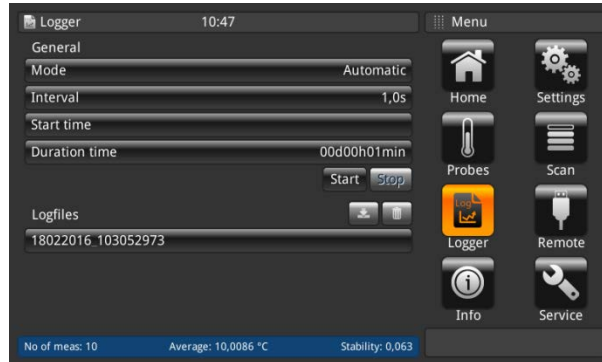

To start a logger with the preferred settings (described below) press the button <<Start>>. Then the <<LOG>> appears in the status line, which shows that the logger is active. By pressing <<Stop>> the logger is stopped and the <<LOG>> disappears in the status line.

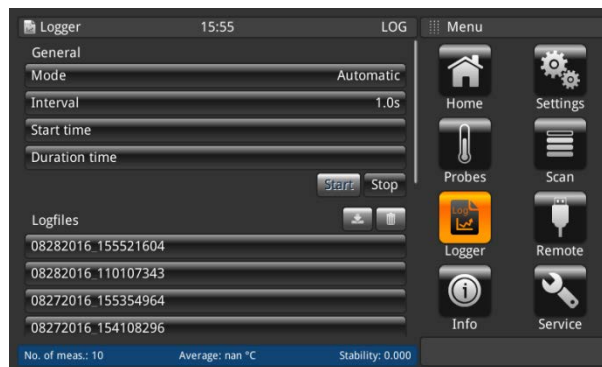

While the logger is active, please do not change the probe configuration, including plugging or unplugging of SMART probes.

4.6.5.1 General

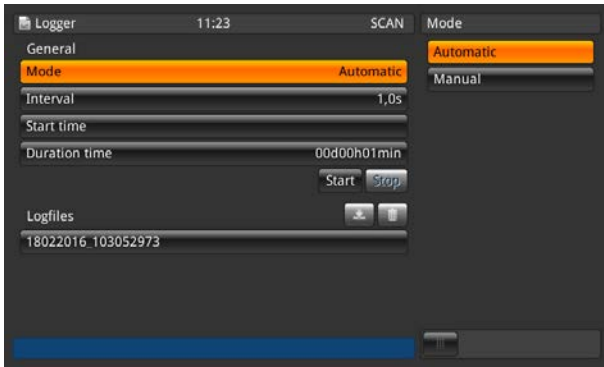

Click on the button <<mode>> and two options are visible on the right side: Automatic and manual

- Automatic mode requires the setting <<interval>>
- Manual mode: A value is taken while pressing the <<Log>> button 3s long, when being in the application <<Home>>

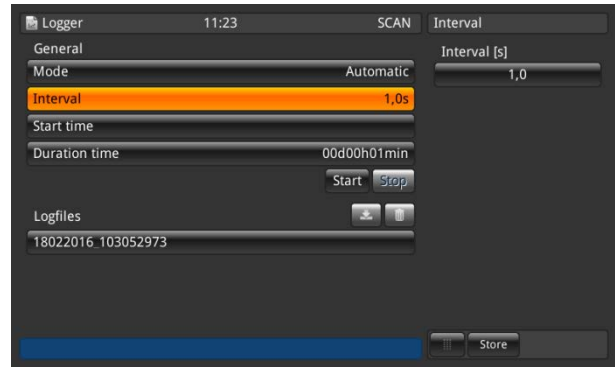

The interval describes the time when the device takes automatically a value from the measurement. Clicking on the button on the right side under the capture <<Interval [s]>> opens a num pad.

Settable values:

- Minimum 0.5 s
- Maximum 3600 s
- Step 0.5
- Standard value = 1 s

Please store the setting.

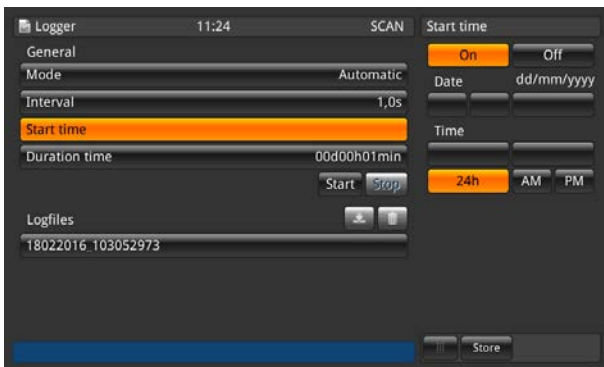

Start time describes the time, when the log starts. A date and a time have to be defined. Please store the setting.

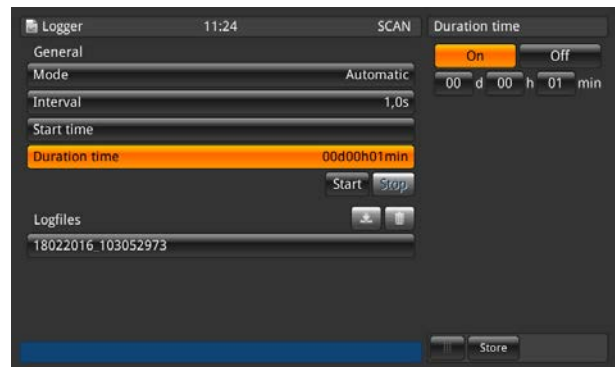

Duration time describes the time, when the log ends after starting. A setting in days, hours or minutes has to be done. Please store the setting.



Please ensure that the date and time is set correct under <<Settings>>.

4.6.5.2 Log files

The device itself has a capability of approx. 1.4 Mio values. If the storage is full, no log files will be overwritten. An error log rises up and requests to delete data from the device.

EN

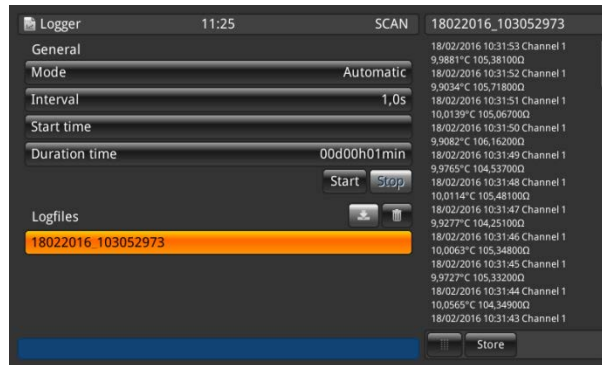

By pressing the button <<Start>> a new log is created and named under log files with a time/date stamp according to the set time/date format. If a start or duration time is selected the button displays also the time until the log starts and then shows the remaining time until it stop.

While clicking on the created log file in the list, the log data will be viewed on the right side and will be updated after every recorded value (the values will be added on the top, that the newest value is always visible).

By pressing the button <<Stop>> the log is done and stored completely under log files.

Delete, download function of log files

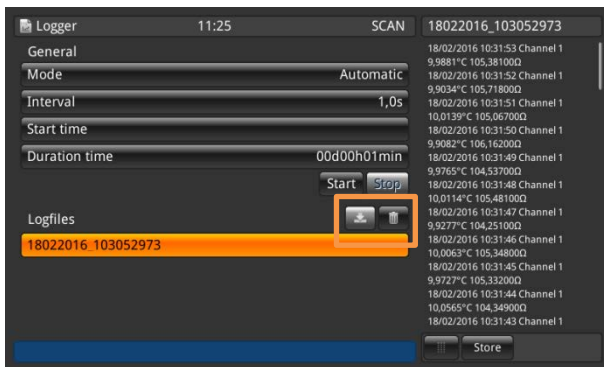

By clicking on an existing log file the values appear on the right side. The head line displays the name of the log file.

Moreover the download  and clear  button are active.



An active log file cannot be downloaded and deleted!

Click on the log file you want to edit. Then click on the download or delete symbol.

If a download is required please ensure that a USB memory stick is inserted in the front end USB! When the download is completed, please ensure that you eject the USB memory stick properly via the  sign in the status line. More details in section **Fehler! Verweisquelle konnte nicht gefunden werden. Fehler! Verweisquelle konnte nicht gefunden werden.**

If the delete button is pressed, a dialog pops up which needs again a confirmation.



If the device cannot detect a memory stick, the download button is inactive.

Stored log data

Via a USB memory stick in the front end USB the log data can be downloaded and can be viewed in e.g. Excel. Open Excel and import the file. Please take care that the data format is chosen with UTF-8.



Please ensure that the decimal separator setting on the device match to your setting on the PC.

Data which is displayed on the screen will be logged. E.g. scan is activated for 2 channels -> 2 channels will be logged.

General data:

- Instrument name
- Serial number, Firmware
- Per channel the probe data (what probe and all settings)
- Start date
- Start time

Log data:

- Time/date stamp
- Channel
- measurement value in °C (or other set standard unit)
- measurement raw data/ electrical value

If one channel is marked as reference, then for all other channels the difference is calculated:

- difference in °C (or other set standard unit)
- difference in raw data/ electrical value



Differences can only be calculated, if the units match.

4.6.6 Application <<Remote>>

EN

This application <<Remote>> allows to operate the device with SCPI commands (command set available in a separate document) over a rear panel USB/Ethernet or RS232 connection.

With the Remote Settings application users can select the remote command set for all interfaces. The Ethernet network parameters and Serial parameters can also be set here.

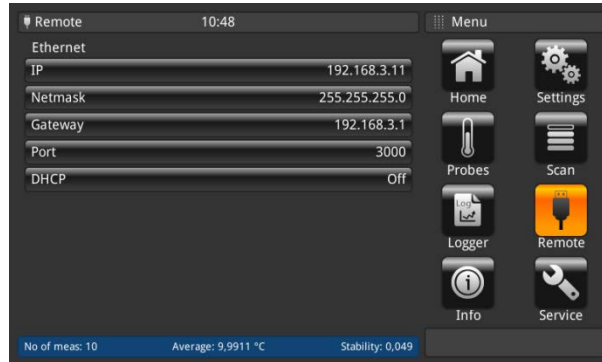

*As a RS232 card is connected more functions will be displayed.

USB

The USB PC interface will be installed as a virtual COM driver. The communication protocol is:

- Bits per second 9600
- Data bits 8
- Stop bits 1
- Parity none
- Flow control none

Ethernet

The Ethernet function allows the user to set the following by inputting a numeric value in each separate field:

- IP
- Netmask
- Gateway
- Port
- DHCP settings

The Ethernet communication parameters are set as a default.

Before using Ethernet communication, four parameters must be set up: IP, Netmask, Gateway, and Port.



Please contact the network administrator for proper settings.

Please consult the computer resources department prior to connecting this instrument to your network to verify there are no conflicts with existing IP addresses.

4.6.7 Application <<Info>>



The Information Application displays information about the instrument, including:

- Wika address
- Model number, serial number and manufacturing date
- Measuring system serial number and firmware version
- User interface serial number and user interface software version
- Used storage

4.6.8 Application <<Service>>

4.6.8.1 Firmware update

Entering the application <<service>> a firmware update under the customer service level can be done while pressing the button <<Firmware update>>. The menu opens on the right side.

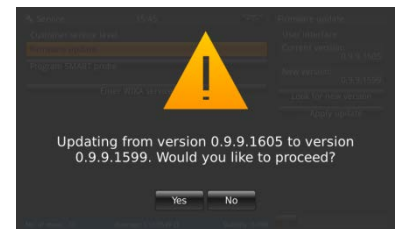
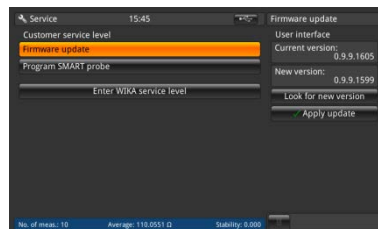
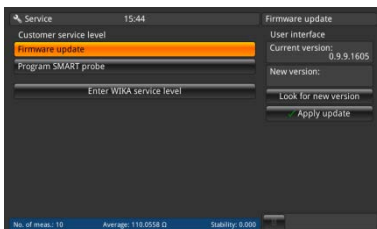

Please ensure that a USB/memory stick with the folder “CTR3000” and the suitable file is inserted. Otherwise the CTR3000 will not recognize the new version.

If a USB stick is inserted press on the button <<Look for a new version>> and then the device search for a suitable file on the USB stick. If one is found the new version number is shown in the field “new version” to install this press the button <<apply update>>.

Please confirm with <<yes>> to update the device with the new firmware. The answer will be <<Firmware update ok>>.

14191761.01 03/2017 EN



If the file cannot be found, an error log is raised.



The firmware update does not delete the settings, probes and log files!

4.6.8.2 Program SMART probe

Entering the application <<service>> the SMART probes can be programmed under the customer service level can be done while pressing the button <<Program SMART probe>>. The menu opens on the right side.

EN

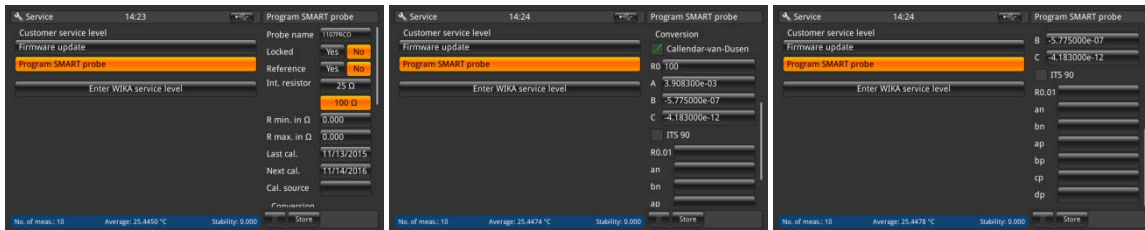

Here all settings can be done which are stored on the EEPROM on this SMART probe. Similar to the settings for new probes. Please refer to section 4.6.3.1 New probe <<Resistance thermometers>> to understand the meaning of these settings.



No history is stored on the memory!



This can only be done while a SMART probe is connected and on the home screen, the channel is selected where the SMART probe is connected. Otherwise an error log is raised.





4.6.8.3 WIKA service level



Only accessible with a password!
Only for authorized users.

4.7 Download function

The device first stores all data on the device, which can be downloaded later on to a USB memory drive. A direct storing process on the USB memory drive is not possible. To enter the download function the device must detect an USB memory stick. Then the symbol  appears in the status bar. Get access to the function while clicking on this symbol .

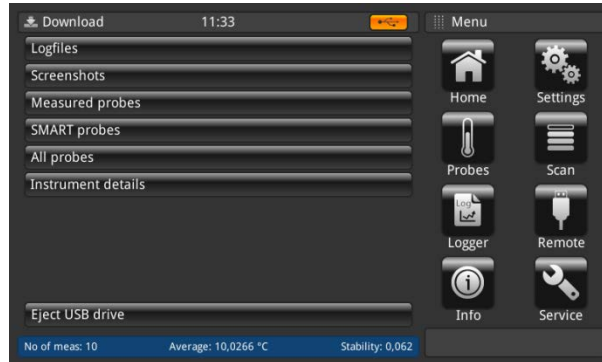

Please ensure that you eject the USB drive every time when you are ready via the function button, to be sure that all data is saved!

All downloaded data will be stored in the directory “CTR3000” in the USB stick’s file system root. The directory will be created, if it does not exist.

4.7.1 Log files

Clicking on log files a dialog opens on the right side. All created log files are listed there. To select or delete these please use the right function button.

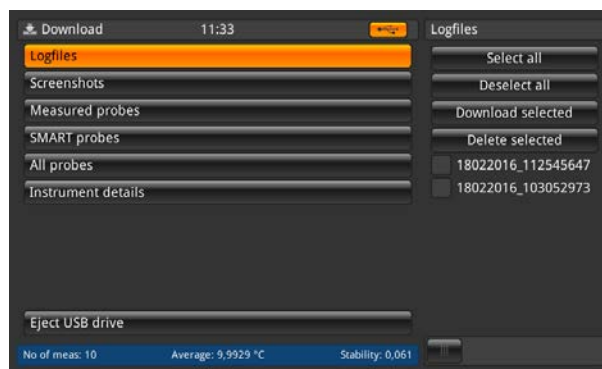

Function button	Result
Select all	Ticks all log files with a ✓ in the box in front of the log file’s name
Deselect all	Removes the ✓ in the box in front of the log file’s name
Download selected	Downloads all log files marked with a ✓ to the USB memory stick
Delete selected	Deletes all log files marked with a ✓ from the device

The downloaded log file is a file in the format *.txt, which can be easily opened in e.g. EXCEL.

Name of a log file in the directory *CTR3000 \Logfiles:

Ddmmyyyy_hhmmss

(This can change according to the set time and date format in the application <<settings>>.)

For details regarding the content of the downloaded log file please refer to section 4.6.5.2 Log files.

4.7.2 Screenshot

Clicking on screenshots a dialog opens on the right side. All created screenshots are listed there. To select or delete these please use the right function button.

EN

Function button	Result
Select all	Ticks all screenshots with a ✓ in the box in front of the screenshot's name
Deselect all	Removes the ✓ in the box in front of the screenshot's name
Download selected	Downloads all screenshots marked with a ✓ to the USB memory stick
Delete selected	Deletes all screenshots marked with a ✓ from the device

The downloaded screenshot is a file in the format *.png.

Name of a screenshot in the directory *CTR3000\Screenshots:

Ddmmyyy_hhmmss

(This can change according to the set time and date format in the application <<settings>>.)

4.7.3 Measured Probes

Clicking on the button <<measured probes>> downloads all details into a *.txt file on the USB memory stick. Only the assigned probes are downloaded.

A window pops up which shows that the download is complete. 

Following information is stored in the file in the directory *CTR3000\measured probes:

- Probe name
- Probe type
- Reference probe
- T min.
- T max.
- Last calibration:
- Thermocouple type [only for thermocouples]
- Cold junction compensation [only for thermocouples]
- PRT type [only for resistance thermometers]
- Wiring [only for resistance thermometers]
- Internal resistor [only for resistance thermometers]
- Standby current [only for resistance thermometers]
- Conversion

4.7.4 SMART probes

Clicking on the button <<SMART probes>> downloads all details into a *.txt file on the USB memory stick. Only the connected SMART probes are downloaded. SMART probes are only available as resistance thermometers.

A window pops up which shows that the download is complete. 

Following information is stored in the file in the directory *CTR3000\SMART probes:

- Probe name
- Probe type
- Reference probe
- Last calibration
- Next calibration
- Calibration source
- Internal resistor
- Conversion
- [Conversion coefficients according to selected conversion]
- Working range
- Locked

4.7.5 All probes

Clicking on the button <<all probes>> downloads all details into a *.txt file on the USB memory stick. All probes which are configured on the device are downloaded.

A window pops up which shows that the download is complete. 

Following information is stored in the file in the directory *CTR3000\all probes:

- Probe name
- Probe type
- Reference probe
- T min.
- T max.
- Last calibration:
- Thermocouple type [only for thermocouples]
- Cold junction compensation [only for thermocouples]
- PRT type [only for resistance thermometers]
- Wiring [only for resistance thermometers]
- Internal resistor [only for resistance thermometers]
- Standby current [only for resistance thermometers]
- Conversion

4.7.6 Instrument details

Clicking on the button <<instrument details>> downloads all details into a *.txt file on the USB memory stick.

A window pops up which shows that the download is complete. 

Following information is stored in the file in the directory *CTR3000\instrument_details:

- Model
- Instrument serial number
- Measuring serial number
- User interface serial number
- User interface version
- Firmware version

4.8 Calibration services

DKD/DAkkS certificate - official certificates:

We recommend that the instrument is regularly recalibrated by the manufacturer, with time intervals of approx. 12 months. The basic settings will be corrected if necessary.

If a RTD or TC simulator is connected to one of the instrument's channels and both the simulator and the CTR3000 are connected to the same computer via USB, please use a USB isolator between the simulator and the computer. Otherwise there is a chance that the measurement value is affected.

4.9 Remote operation

All commands can be found in a separate document.

5. Transport, packaging and storage

5.1 Transport

Check the instrument for any damage that may have been caused by transport. Obvious damage must be reported immediately.



CAUTION!

Damage through improper transport

With improper transport, a high level of damage to property can occur.

- ▶ When unloading packed goods upon delivery as well as during internal transport, proceed carefully and observe the symbols on the packaging.
- ▶ With internal transport, observe the instructions in chapter 5.2 "Packaging and storage".

If the instrument is transported from a cold into a warm environment, the formation of condensation may result in instrument malfunction. Before putting it back into operation, wait for the instrument temperature and the room temperature to equalise. A warm up time of 30 minutes is recommended. Please refer to section 4.3.2 Warm up time for any details.

5.2 Packaging and storage

Do not remove packaging until just before mounting.

Keep the packaging as it will provide optimum protection during transport (e.g. change in installation site, sending for repair).

Permissible conditions at the place of storage:

- Relative humidity: 0 ... 80 % r. h. (no condensation)
- Storage temperature -20 ... +50 °C (-4 ... +122 °F)

Avoid exposure to the following factors:

- Direct sunlight or proximity to hot objects
- Mechanical vibration, mechanical shock (putting it down hard)
- Soot, vapour, dust and corrosive gases
- Hazardous environments, flammable atmospheres

Store the instrument in its original packaging in a location that fulfils the conditions listed above. If the original packaging is not available, pack and store the instrument as described below:

1. Wrap the instrument in an antistatic plastic film.
2. Place the instrument, along with shock-absorbent material, in the packaging.
3. If stored for a prolonged period of time (more than 30 days), place a bag, containing a desiccant, inside the packaging.

6. Commissioning, operation

EN

Personnel: Skilled personnel

Only use original parts (see chapter 11 “Accessories”).



CAUTION!

Damage to the instrument

When working on open electrical circuits (printed circuit boards) there is a risk of damaging sensitive electronic components through electrostatic discharge.

- ▶ The correct use of grounded working surfaces and personal armbands is required.

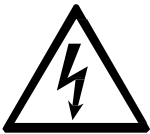

DANGER!

Danger to life caused by electric current

Upon contact with live parts, there is a direct danger to life.

- ▶ The instrument may only be installed and mounted by skilled personnel.
- ▶ Operation using a defective power supply unit (e.g. short-circuit from the mains voltage to the output voltage) can result in life-threatening voltages at the instrument!

7. Faults

Personnel: Skilled personnel

EN



For contact details, please see chapter 1 “General information” or the back page of the operating instructions.

Faults	Causes	Measures
OL	No reading	Check if probe is proper connected.

8. Maintenance, cleaning and servicing

EN

Personnel: Service personnel

8.1 Maintenance

This instrument is maintenance-free.

Repairs must only be carried out by the manufacturer.
Only use original parts (see chapter 11 "Accessories").

8.2 Cleaning



CAUTION!

Physical injuries and damage to property and the environment

Improper cleaning may lead to physical injuries and damage to property and the environment. Residual media in the dismantled instrument can result in a risk to personnel, the environment and equipment.

► Carry out the cleaning process as described below.

1. Before cleaning, correctly disconnect the thermometer from the temperature heater, switch the device off and disconnect it from the mains.
2. Use the requisite protective equipment.
3. Clean the instrument with a moist cloth.

Electrical connections must not come into contact with moisture!



CAUTION!

Damage to the instrument

Improper cleaning may lead to damage to the instrument!

- Do not use any aggressive cleaning agents, alcohol or thinners.
- Do not use any hard or pointed objects for cleaning.
- Do not use a hard or abrasive brush.

Wash or clean the dismantled instrument, in order to protect persons and the environment from exposure to residual media.

8.3 Recalibration

DKD/DAkkS certificate - official certificates:

We recommend that the instrument is regularly recalibrated by the manufacturer, with time intervals of approx. 12 months. The basic settings will be corrected if necessary

9. Dismounting, return and disposal

Personnel: Skilled personnel



WARNING!

Physical injuries and damage to property and the environment through residual media

Residual media in which the thermometer is inserted can result in a risk to persons, the environment and equipment.

- ▶ Wear the requisite protective equipment (see chapter 3.6 “Personal protective equipment”).
- ▶ Observe the information in the material safety data sheet for the corresponding medium.
- ▶ Wash or clean the dismantled instrument, in order to protect persons and the environment from exposure to residual media.

9.1 Dismounting



WARNING!

Risk of burns

During dismantling there is a risk of dangerously hot media escaping.

- ▶ Let the instrument/thermometer cool down sufficiently before dismantling it!



DANGER!

Danger to life caused by electric current

Upon contact with live parts, there is a direct danger to life.

- ▶ The dismantling of the instrument may only be carried out by skilled personnel.
- ▶ Only disconnect the pressure measuring instrument/measuring assembly/test and calibration installations once the system has been disconnected from the power!

9.2 Return

Strictly observe the following when shipping the instrument:

All instruments delivered to WIKA must be free from any kind of hazardous substances (acids, bases, solutions, etc.) and must therefore be cleaned before being returned.



WARNING!

Physical injuries and damage to property and the environment through residual media

Residual media in the dismantled instrument can result in a risk to persons, the environment and equipment.

- ▶ With hazardous substances, include the material safety data sheet for the corresponding medium.
- ▶ Clean the instrument, see chapter 8.2 “Cleaning”.

When returning the instrument, use the original packaging or a suitable transport packaging.

To avoid damage:

EN

1. Wrap the instrument in an antistatic plastic film.
2. Place the instrument along with shock-absorbent material in the packaging. Place shock-absorbent material evenly on all sides of the transport packaging.
3. If possible, place a bag containing a desiccant inside the packaging.
4. Label the shipment as carriage of a highly sensitive measuring instrument.



Information on returns can be found under the heading “Service” on our local website.

9.3 Disposal

Incorrect disposal can put the environment at risk.

Dispose of instrument components and packaging materials in an environmentally compatible way and in accordance with the country-specific waste disposal regulations



This marking on the instruments indicates that they must not be disposed of in domestic waste. The disposal is carried out by return to the manufacturer or by the corresponding municipal authorities (see EU directive 2012/19/EU).

10. Specifications

For further specifications see WIKA data sheet CT 60.15 and the order documentation.

More specific data for thermocouples

TC-Type	Working Range [°C]		Working Range [mV]	
	min	max	min	max
B	250	1820	0.291	13.820
E	-200	1000	-8.825	76.373
J	-210	1200	-8.095	69.553
K	-200	1372	-5.891	54.886
N	-200	1300	-3.990	47.513
R	-50	1768	-0.226	21.103
S	-50	1768	-0.235	18.693
T	-200	400	-5.603	20.872

Type of probe Accuracy

B	$\pm 0.09 \text{ °C} + \pm 0.025 \text{ \% of rdg.}$
E	$\pm 0.05 \text{ °C} + \pm 0.031 \text{ \% of rdg.}$
J	$\pm 0.07 \text{ °C} + \pm 0.030 \text{ \% of rdg.}$
K	$\pm 0.09 \text{ °C} + \pm 0.035 \text{ \% of rdg.}$
N	$\pm 0.08 \text{ °C} + \pm 0.035 \text{ \% of rdg.}$
R	$\pm 0.27 \text{ °C} + \pm 0.020 \text{ \% of rdg.}$
S	$\pm 0.27 \text{ °C} + \pm 0.020 \text{ \% of rdg.}$
T	$\pm 0.09 \text{ °C} + \pm 0.025 \text{ \% of rdg.}$



The maximum cable length of all attached cables e.g. temperature probe or interface cables is 2 m.

To reach the maximal accuracy an ambient temperature between 17°C and 23°C must be fulfilled.

In the event of interference caused by high-frequency electromagnetic fields in a frequency range from 400 to 480 MHz, an increased measuring deviation of up to 0.29 K is expected for resistance thermometers. In a frequency range from 380 to 480 MHz, an increased measuring deviation of up to 0.12 K is expected for thermocouples. Intended to be used in a basic electromagnetic environment.

11. Technical information

11.1 Measurement uncertainty and traceability

EN

Measurement is usually made on the assumption that there is a true value. Whenever a measurement is performed it is unlikely that the measured value will equal the true value. The difference between the two values is the measurement error which will lie within the specified limits of uncertainty. Uncertainty is defined as an estimate characterising the range of values within which the true value lies.

By taking a statistically significant number of measurement samples, a distribution of results will emerge. Confidence in the distribution increases as more measurements are made. Using statistical methods, the distribution may be described in terms of mean, variance and standard deviation. The uncertainty or precision limit of a particular measurement is characterised by this distribution.

Traceability is defined as the property of a measurement that may be related to appropriate reference standards through an unbroken chain of comparisons. Through traceability it is possible to demonstrate the accuracy of a measurement in terms of SI units.

11.2 International temperature scale

The purpose of the International Temperature Scale is to define procedures by which certain specified practical thermometers including PRTs and thermocouples of the required quality can be calibrated. The values of temperature obtained from them can be precise and reproducible, matching at the same time the corresponding thermodynamic values as closely as current technology permits.

Since 1968 when the International Practical Temperature Scale of 1968 (IPTS68) was adopted, there have been significant advances in the techniques employed in establishing temperature standards and in the measurement of thermodynamic temperature. The International Temperature Scale of 1990 (ITS-90) gives practical effect to these improvements. Particular features are:

- ITS-90 specifies the use of the PRT up to the freezing point of silver, 961.78°C. The platinum 10% rhodium/platinum thermocouple is no longer specified for use in the scale, though it and other noble metal thermocouples will continue to be used as secondary standards.
- New, more precise, fixed points have been introduced and mathematical procedures for calculating resistance temperature equivalents have been revised so as to reduce the 'non-uniqueness' of the scale: that is, to reduce the differences which occur between different, identically calibrated PRTs. In particular, the calibration of a PRT can no longer be extrapolated beyond the freezing point of zinc, 419.527°C, but requires a measurement at the freezing point of aluminium, 660.323°C.
- Alternative definitions are permitted in certain sub-ranges; the calibration of a PRT can be terminated at almost any fixed point. This allows primary calibrations to be carried out with suitable PRTs over reduced ranges, and will be of special importance to metrology standards departments which need to make precise measurements at ambient temperatures.

- The part of the ITS-90 scale which may be measured by PRTs extends from 83.8058 K (-189.3442°C) to 961.78°C. The CTR3000 is specified to measure temperature over the range -200°C to +962°C. The actual range of temperatures which may be measured depends on the type and range of the PRT.

The ITS-90 scale has much improved continuity, precision and reproducibility compared with IPTS68. The implementation of the ITS-90 scale according to its definition calls for changes in equipment and procedure compared with IPTS68, but lower uncertainties of calibration are achievable in all parts of the range. However, the instruments and equipment needed to implement the ITS-90 scale in calibration laboratories will be substantially the same.

11.3 Measurement

11.3.1 Thermocouple

11.3.1.1 Introduction

Very broadly the thermoelectric effect occurs when an electrical circuit consisting of dissimilar metal conductors is subjected to a temperature gradient. An electric potential or voltage is developed along the conductors. This voltage potential varies proportionally with temperature and provides a means by which to measure temperature.

There are two categories of thermocouple:

Rare metal, Platinum based types

Rare metal, platinum types are mostly used for high temperature precision thermometry. Maximum temperatures of 1700°C and measurement uncertainties of up to 0.4°C are possible. The sensitivity of platinum based thermocouples is usually in the region of 10µV/ °C, which means that high accuracy, high resolution measurements require sensitive instruments such as the CTR3000.

Base metal, Nickel based

Base metal thermocouples operate over a wide temperature range with high temperature types designed for use up to 1600°C. Temperatures above 2300°C are possible with new high temperature tungsten rhenium types. Typical sensitivity figures of >30µV/ °C characterise most of the base metal thermocouple family.

These are easily affected by contamination effects which results in recalibration and drift. This is especially pronounced at high temperatures where drift figures of the order of 10°C are possible. It is important to be aware of the particular contamination effects and to select the correct thermocouple for the measurement environment. The N type thermocouple offers the best performance in terms of reproducibility and measurement uncertainty, operating up to 1250°C. It is the best choice for most general measurement applications, calling for accuracy with low time and temperature drift

11.3.1.2 Connection

Thermocouples measure temperature difference. As all practical thermocouples consist of at least 2 junctions, it is important when performing absolute temperature measurement that one of the junctions is referenced to a known temperature.

The reference junction and voltage measurement precision significantly influence the overall temperature measurement accuracy. Intermediate connection junctions such as connectors and extension cables between the measurement thermocouple and the CTR3000 also influence the measurement result.

11.3.2 Resistance thermometer

The CTR3000 will operate with a range of 3 and 4-wire 25/100 Ohm PRTs. The best performance will be achieved only where good quality PRTs are used from reputable, proven sources. As with any measured parameter, the performance of a measurement system depends upon its stability and repeatability. Low quality PRTs are likely to reduce system performance.

The relationship between temperature and resistance depends on several factors, including the alpha value and the PRT calibration. Consequently more than one equation is required for resistance to temperature conversion. Calibration data for the PRTs takes the form of Callendar van Dusen coefficients.

WIKA provides a range of proven PRTs of the series CTP5000 especially for use with the CTR3000, as well as offering a service to provide customised PRTs to meet individual customers' requirements.

High "alpha" PRTs: The best possible system accuracy is achieved using high "alpha" (α) PRTs, or more correctly, PRTs using high α (high purity) platinum wire.

Low "alpha" PRTs: Low α PRTs contain a higher level of impurities in the platinum resistance wire used. This affects the resistance value at a given temperature (the temperature coefficient). As impurities already exist in the platinum resistance wire, additional contamination has a reduced effect and hence low α PRTs are more immune to contamination and are therefore better for industrial applications. To ensure a robust PRT, the detector within the PRT is contained within materials, which can themselves be the source of contamination at elevated temperatures. The PRTs supplied by WIKA have been optimised for the temperature ranges for which they are specified and, when calibrated, are temperature cycled to enhance stability in use.

PRTs which are used outside their design and/or calibration temperature range, especially at higher temperatures, risk irreversible alteration to their calibration either by induced thermal stresses or by contamination.

11.3.2.1 Linearization functions for resistance thermometers

The CTR3000 provides one standard and 2 user definable algorithms for converting resistance to temperature. The choice will depend on the type of PRT and its calibration.

- Standard: EN60751 (2009):- used for un-calibrated industrial PRTs with 0.003851 “alpha” value, to provide a conversion of resistance to temperature in accordance with the EN60751 (ITS 90) standard.

Selecting EN60751 from the standard menu selects the standard coefficients from BS EN60751 based on ITS90. The coefficients for EN60751 are as follows:

$$R_0 = 100 \text{ Ohm}$$

$$A = 3.9083 \times 10^{-3} \text{ } ^\circ\text{C}^{-1}$$

$$B = -5.775 \times 10^{-7} \text{ } ^\circ\text{C}^{-2}$$

$$C = -4.183 \times 10^{-12} \text{ } ^\circ\text{C}^{-4}$$