

# OVAL GEAR FLOWMETER ELECTRONIC MODEL 006/009 (1/4")

INSTRUCTION MANUAL— 'F' Serial Meters

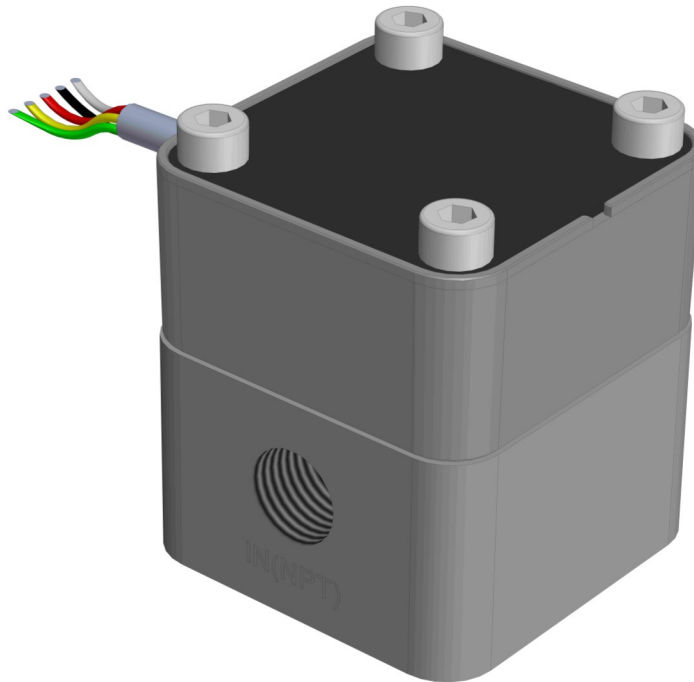

## To the Owner

### **PLEASE READ THIS SAFETY INFORMATION CAREFULLY BEFORE USE.**

Read and retain this instruction manual to assist you in the operation and maintenance of this product.

If you have any problems with the meter, refer to the maintenance and trouble shooting sections of this manual.

This manual contains connection and operating instructions for meters with Pulse outputs.

Models with a Liquid Crystal Display have an additional LCD instruction manual supplied. If you need further assistance, contact your local representative or distributor for advice.

This Flow Meter has incorporated the oval rotor principal into its design. This has proven to be a reliable and highly accurate method of measuring flow.

Exceptional repeatability and high accuracy over a wide range of fluid viscosities and flow rates are features of the oval rotor design. With a low pressure drop and high pressure rating oval rotor flow meters are suitable for both gravity and pump (in line) applications.

This instruction manual covers pulse meters constructed in Aluminium or Stainless Steel. Also included are the high pressure versions of this model.

## Important Information



### WARNING

**Before use, confirm the fluid to be used is compatible with the meter. Refer to Industry fluid compatibility charts or consult your local representative for advice.**

To prevent damage from dirt or foreign matter it is recommended that a Y or Basket type 200 mesh strainer be installed as close as possible to the inlet side of the meter. Contact your local representative for advice.



### CAUTION

**When a strainer is installed it should be regularly inspected and cleaned. Failure to keep the strainer clean will dramatically effect flow meter performance.**



### CAUTION

**To prevent damage caused by air purge slowly fill the meter with fluid. To reduce pressure build up turn off the pump at the end of each day.**

Maintenance can be carried out to the liquid crystal displays and pulse units without removing or isolating the meter from the line. When maintenance to any other part of the meter is required, the meter must be isolated and the line pressure reduced.

The reed switch pulse unit can cause inaccurate rate counts when used with high speed counters. It is advised that a debounce circuit be used. Contact your meter distributor for further information.

## Operating Principle

When fluid passes through the meter the rotors turn, as shown below. The magnets which are located in the rotors will pass across the pulser circuit board (containing either Reed switches or Hall Effect sensors). A signal is generated which is then sent by the Pulse Circuit Board (PCB) to the relevant LC display or receiving instrument..

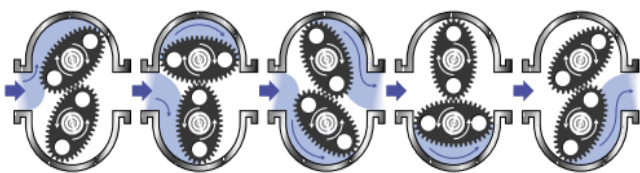

## Installation Procedure

- 1) It is recommended that when setting up pipe work for meter installations a bypass line be included in the design. This provides the facility for a meter to be removed for maintenance without interrupting production. (see figure)
- 2) Use thread sealant on all pipe threads.
- 3) For pump applications ensure pipe work has the appropriate working pressure rating to match the pressure output of the pump. See Meter Specifications section for further details.
- 4) Install a wire mesh strainer, Y or basket type 200 mesh (74 micron), as close as possible to the inlet side of the meter.
- 5) Ensure that the meter is installed so that the flow of the liquid is in the direction of the arrows embossed on the meter body.

- 6) The meter can be installed in any orientation as long as the meter shafts are in a horizontal plane. (Refer to figures to the right for correct installation) The register assembly may be orientated to suit the individual.  
*Note:* Incorrect installation can cause premature wear of meter components.

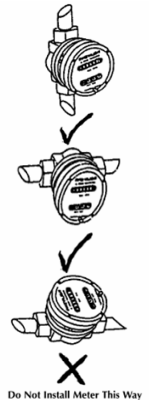

- 7) Do not over tighten meter connections. *Note:* Incorrect installation can cause premature wear of meter components.
- 8) It is important that after initial installation you fill the line slowly, high speed air purge could cause damage to the rotors.
- 9) Test the system for leaks.
- 10) Check the strainer for swarf or foreign material, after the first 200 litres check periodically, particularly if the flow rate decreases.

## Maintenance Procedures

### Disassembly

Ensure that the fluid supply to the meter is disconnected, and the line pressure is released before disassembly, with the exception for repair or maintenance to the LC Display or PCB where there is no necessity to isolate the meter from flow. Refer to the exploded parts diagram on subsequent pages for item numbers.

1. Loosen and remove 4 Phillips head or cap head screws (Item 7), see Page 7.
2. Remove the meter cap (Item 5) and O-Ring (Item 4).
3. Remove the rotors (Item 2 & 3), note the position of the rotor with the magnet(s) or grub screws
4. Clean and inspect all components, replace as necessary, see page 8 for spare parts listing.

### Reassembly

1. Replace the rotors (Item 2 & 3), see below for correct orientation. Rotate the rotors by hand to ensure correct engagement.
2. Fit the O-Ring (Item 4) into the O-Ring groove in the meter body (Item 1).
3. Fit the top cap assembly (Item 5), fit the legend plate (Item 6) into correct orientation. Ensure all the alignment marks are lined up with the mark on the body.
4. Fit and tighten the 4 bolts/screws (1-3-2-4) to the required torque.
5. Check meter function using low air pressure.
6. Restore the fluid & reconnect the wiring as detailed on page 5.

### Troubleshooting Guide

Problem	Cause	Remedy
Fluid will not flow through meter	a) Foreign matter blocking rotors b) Line strainer blocked c) Damaged rotors d) Meter connections over tightened e) Fluid is too viscous	a) Dismantle meter, clean rotors (strainer must be fitted in line) b) Clean strainer c) Replace rotors (Strainer must be fitted in line) d) Re-adjust connections e) See specifications for maximum viscosity
Reduced flow through meter	a) Strainer is partially blocked b) Fluid is too viscous	a) Clean strainer b) See specifications for maximum viscosity
Meter reading inaccurate	a) Fluid flow rate is too high or too low b) Air in fluid c) Excess wear caused by incorrect installation	a) See specifications for minimum and maximum flow rates b) Bleed air from system c) Check meter body and rotors. Replace as required. Refer to installation instructions
Meter not giving a pulse signal	a) Faulty hall effect sensor b) Faulty reed switch c) Magnets failed	a) Replace PCB Board b) Replace PCB Board c) Replace magnets
LCD register not working	a) Battery not connected properly b) Battery flat c) Faulty wiring connections d) Faulty LC Display e) Faulty connection from LC Display	a) Check battery connections b) Replace battery c) Check wiring for loose or faulty connections d) Replace LC Display e) Check wiring connections

Note:  
The Active Rotor, Alignment Dimple and Cap Notch must be aligned when assembling the flow-meter

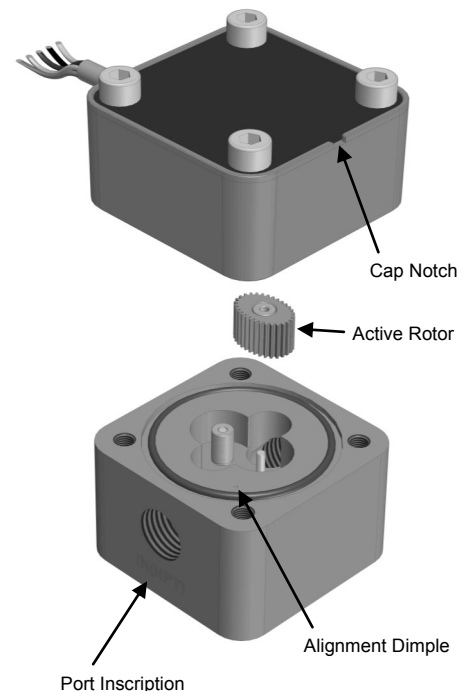

Note: 'CR' Range has a notch in the body not an alignment dimple.

'MH' Range can have the active rotor in either location.

Magnet hole/grub screw side must be facing the meter body.

## Flowmeter

			Metric	US
<b>006 Flowmeter Range</b>	Flow Range	Below 5 cP	2 - 100 l/hr	0.5 - 26 G/hr
		5 to 1000 cP	0.5 - 100 l/hr	0.13 - 26 G/hr
	K-Factor (Pulses per Unit of Measure)		Refer to Flowmeter Data Plate	
<b>009 Flowmeter Range</b>	Flow Range	Below 5 cP	25 - 500 L/hr	6.6- 130 G/hr
		5 to 1000 cP	15 - 500 L/hr	4 - 130 G/hr
	K-Factor (Pulses per Unit of Measure)		Refer to Flowmeter Data Plate	
Standard Operating Temperature - Types F,S,CR,			-40 to 80°C	-40 to 176°F
- Types M,MH			-40 to 120°C	-40 to 248°F
Maximum Operating Pressure <sup>1</sup>				
<ul style="list-style-type: none"> <li>• CR - Corrosive Range</li> <li>• S - Solvent Range</li> <li>• F - Fuel and Oil</li> <li>• M - Industrial Range</li> <li>• MH - High Pressure Industrial Range</li> </ul>			500 kPa 1000 kPa 1000 kPa 5500 kPa 55000 kPa	75 PSI 150 PSI 150 PSI 800 PSI 8000 PSI
Accuracy of Reading			±1%	

1. Conforms to Directive 97/23/EC—Cat 1

## High Specification Flow Meters

The following specifications apply when high temperature or high viscosity options are used.

	Metric	US
High Temperature	120°C	248°F
High Pressure (MH Model)	55000 kPa	8000 psi
High Viscosity	Above 1000 Centipoise	

## Pulser Board/Sensor Specifications

There are 2 pulse board options with all Macnaught pulse flowmeters:

Standard Option 1 - 1 x Reed Switch 1x Hall Effect Output

Hazardous Option 2 - 1 x Reed Switch Output

Output Signals	Standard Pulse Meter		2x Digital (Square Wave)
Reed Switch <sup>2</sup> (Mechanical Sensor)	Current	Maximum	500mA
	Voltage	Maximum	30V DC
	Contact Rating	Maximum <sup>3</sup>	10W
Hall Effect IC <sup>2</sup> (Electronic Sensor)	Maximum Supply Current		7.5mA
	Maximum Output Current		25mA
	Operating Voltage		4.5V to 24V DC
	Transistor Type		Open-Collector NPN

2. Voltage & current specifications apply per sensor (not combined).

3. Contact rating maximum is 10W. Neither current nor voltage maximums should be exceeded in achieving this.

# Analogue Output (4-20mA)

Analogue outputs are available as an auxiliary display signal by including the following LCD displays with your flowmeter. These may be fitted to the meter or remote (wall mount) types.

- |            |   |                       |
|------------|---|-----------------------|
| <b>DRA</b> | Small display with analogue output module | Remote or Meter Mount |
| <b>ERA</b> | Large display with analogue output module | Remote Mount only     |

## Pulser Wiring Diagram - MH Model



**Please read this information carefully before installation**

**Hall Effect:**

Hall effect sensors require an external pull up resistor to be fitted by the installer for correct operation. Powering a Hall effect sensor without a resistor wired between the supply voltage and the signal line will result in damage to the sensor.

**Reed Switch:**

In order to protect the reed switch from over current, and to maximise life expectancy, we recommend limiting the current through the switch by fitting a series resistor in between the signal leg and the PLC/signal sensing device.

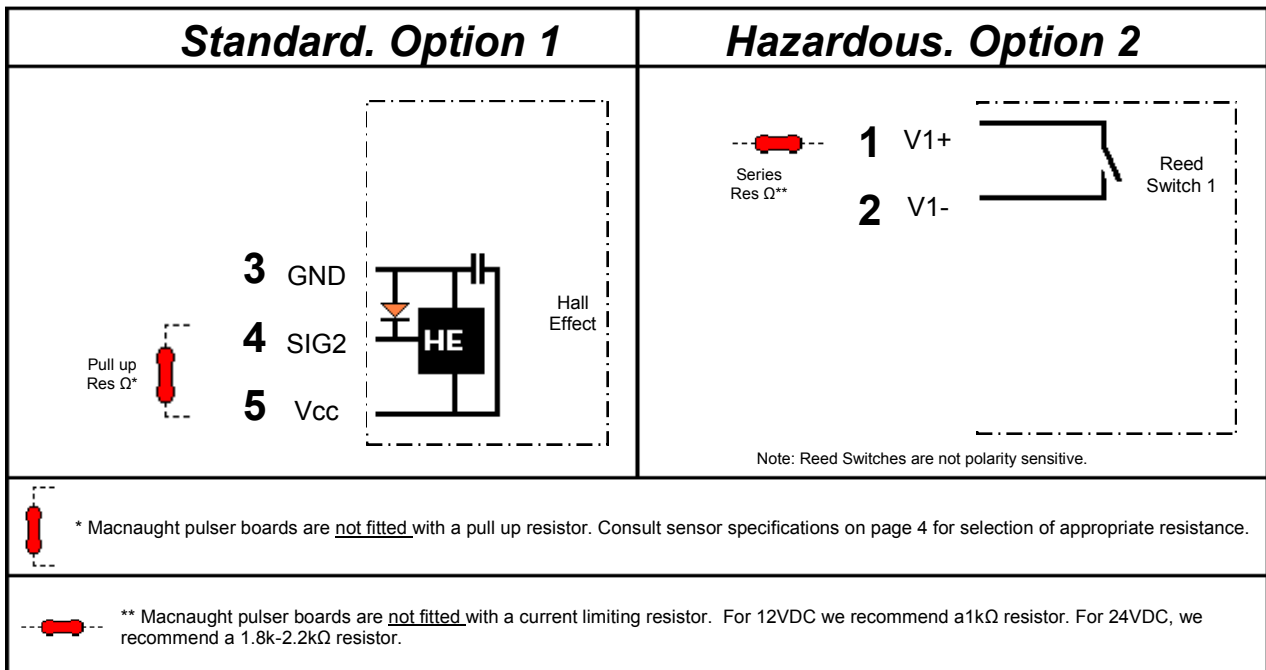

**Note:** Consult the following instruction sheets if the flow meter is fitted with an LCD Display.

Display Part Number:	DR	DRA	ER	ERB	ERA	ERS
Instruction Sheet:	DR013	DR014	MS574	MS392	MS476	MS351



**Please read this information carefully before installation**

**Hall Effect:**

Hall effect sensors require an external pull up resistor to be fitted by the installer for correct operation. Powering a Hall effect sensor without a resistor wired between the supply voltage and the signal line will result in damage to the sensor.



\* Macnaught pulser boards are not fitted with a pull up resistor. Consult sensor specifications on page 4 for selection of appropriate resistance.

**Reed Switch:**

In order to protect the reed switch from over current, and to maximise life expectancy, we recommend limiting the current through the switch by fitting a series resistor in between the signal leg and the PLC/signal sensing device.



\*\* Macnaught pulser boards are not fitted with a current limiting resistor. For 12VDC we recommend a 1kΩ resistor. For 24VDC, we recommend a 1.8k-2.2kΩ resistor.

**Sensor Wiring Connections**

Output Type	Wire	Function	Wire	Function	Wire	Function	Note
Reed/Hall	Reed	Green	Yellow				No Polarity Required
	Hall	Red	+ VDC	Black	Gnd (0V)	White	NPN Open Collector
Reed/Reed	Reed	Green	Yellow				No Polarity Required
Dual Hall		Red	+ VDC	Black	Gnd (0V)	White	NPN Open Collector
Reed/Hall LCD	Reed	Black	Black				Connects to LCD
	Hall	Red	+ VDC	Black	Gnd (0V)	White	NPN Open Collector

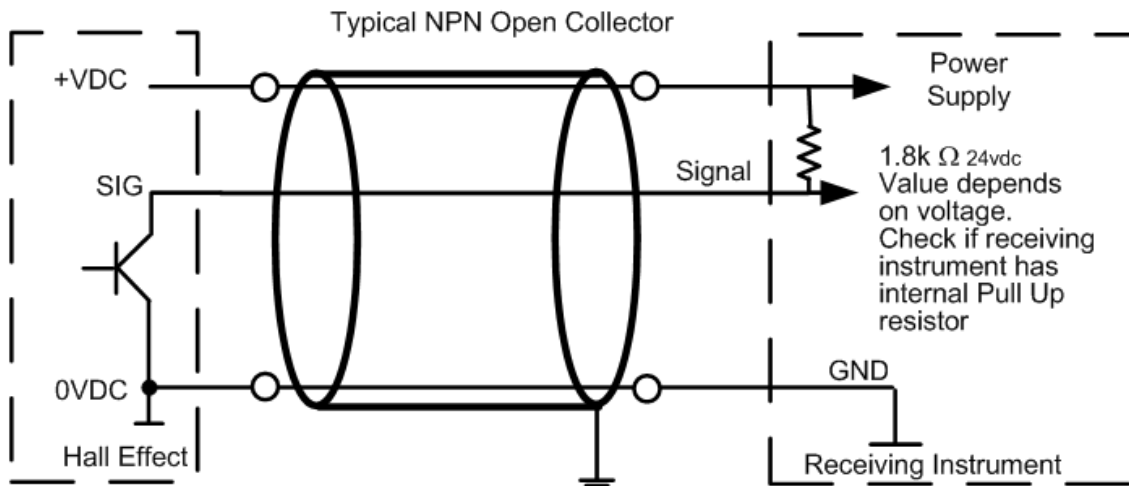

## Exploded Diagram - Type M,F,S,CR

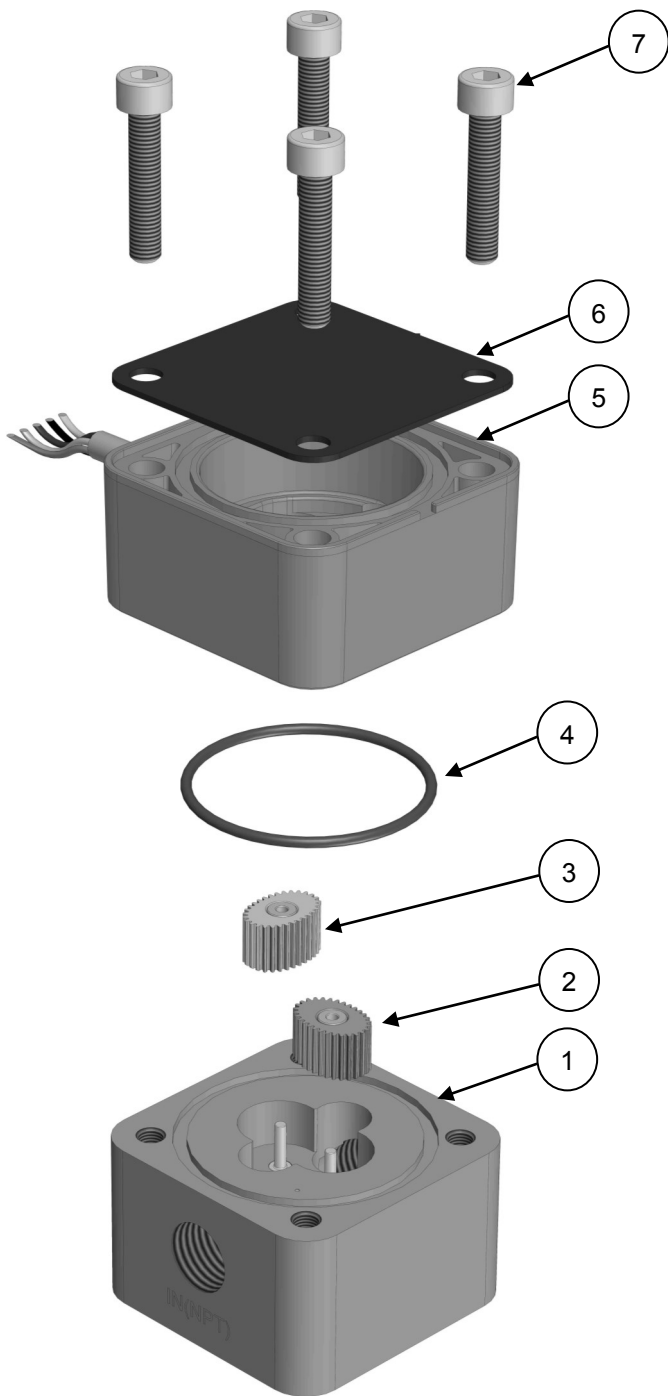

Item N°	Part Description
1	Meter Body
2	Active Rotor
3	Neutral Rotor
4	O-Ring
5	Meter Cap
6	Legend Plate
7	Meter Cap Screws





## Seal Kit - (for Models M,F,S and CR)

Customer Model Number

<b>F</b>	<b>006</b>	<b>—</b>	<b>1</b>	<b>S</b>	<b>2</b>
----------	------------	----------	----------	----------	----------

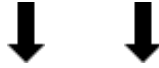

Coding Sequence

<b>SKit</b>	<b>—</b>	Type	Size
-------------	----------	------	------

Kit Components

Order Number	Components	Qty	Items
e.g <b>SKit – F006</b>	Meter Body O-Ring	1	7

## Rotor Kit - (for Models M,F,S and CR)

Customer Model Number

<b>F</b>	<b>006</b>	<b>—</b>	<b>1</b>	<b>S</b>	<b>2</b>
----------	------------	----------	----------	----------	----------



Coding Sequence

<b>RKit</b>	<b>—</b>	Type	Size	<b>—</b>	<b>S</b>
-------------	----------	------	------	----------	----------

Kit Components

Order Number	Components	Qty	Items
e.g <b>RKit – F006 – S</b>	Complete Rotor Assembly	1 set	5+6
	Meter Body O-Rings	1	7
	Meter Cap Screws	4	4

## Cut Away Diagram - Type MH High Pressure

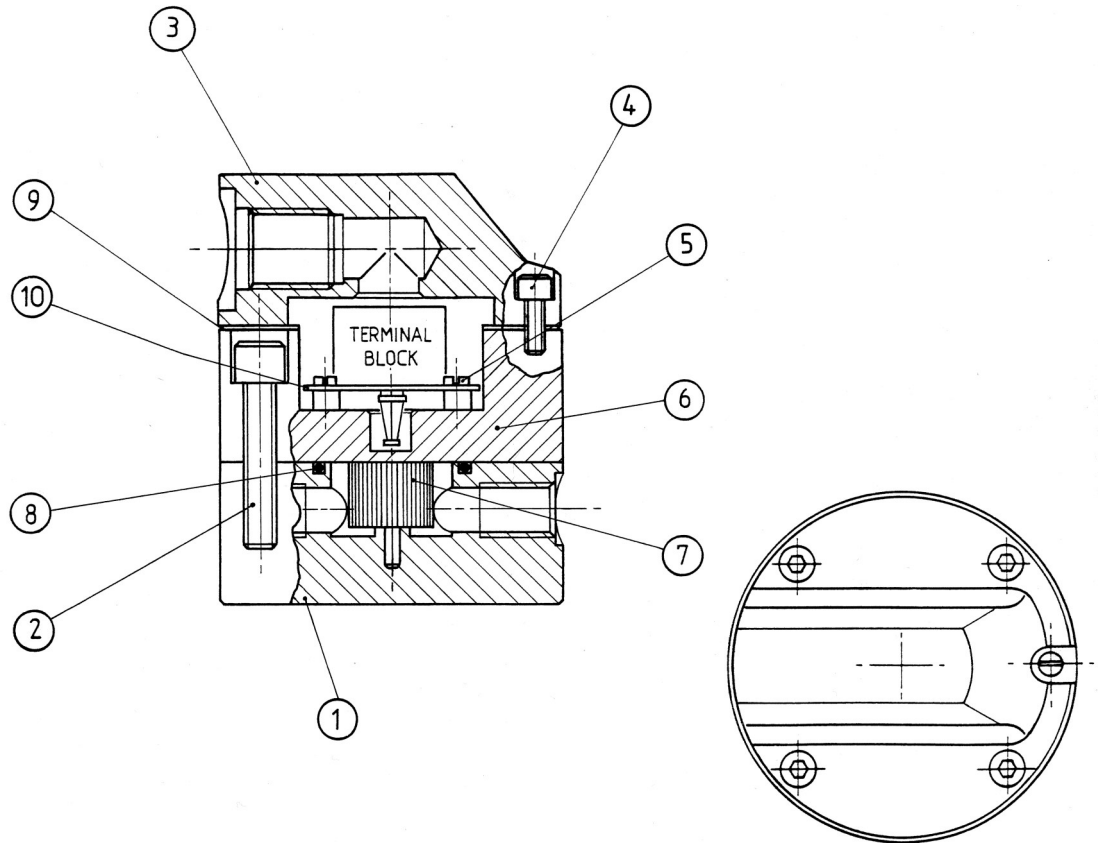

## Parts Identification - Type MH

Item No.	Part Description
1	Meter Body
2	Bolt Set
3	Pulser Cap
4	Pulser Cap Screws
5	PCB screws
6	Meter Cap
7	Rotor Set
8	Meter Cap O-Ring
9	Pulser Cap Gasket
10	PCB

## Spare Parts Kits - (Type MH only)

There are 3 **Spare Kit** options available for the purchase of replacement components:

- Pulser Kit (PKit) - Replacement Pulser Cap
- Rotor Kit (RKit) - Complete Rotor assembly
- Seal Kit (SKit) - Complete set of O-Rings/Gaskets

### Spare Kit Coding Procedure.

1. Determine what type of Spare Parts Kit is required (e.g. Rotor Kit)
2. Use the 'Coding Sequence' to construct a part number according to the meter type.

## Pulser Kit - (Type MH only)

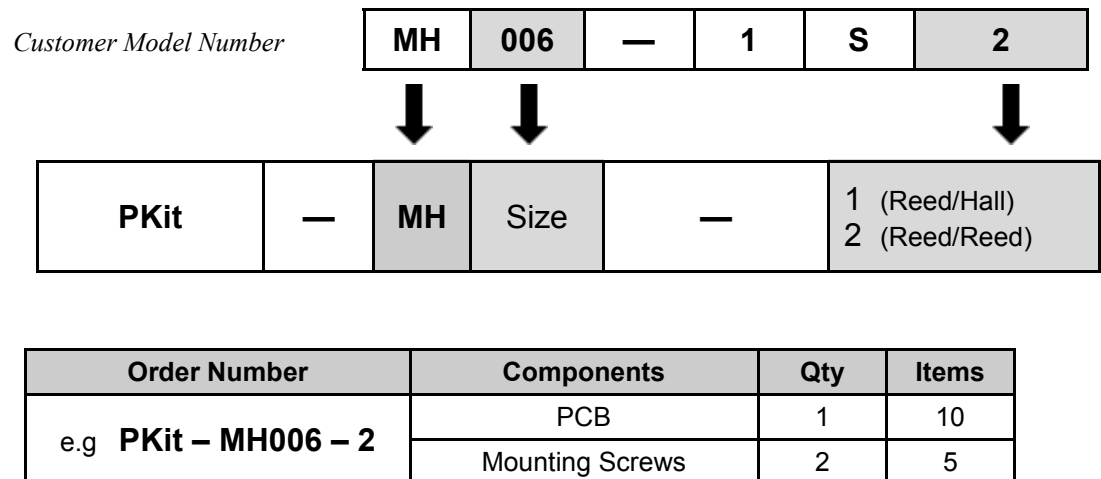

## Seal Kit - (Type MH only)

Customer Model Number

MH	006	—	1	S	2
----	-----	---	---	---	---



Coding Sequence

SKit	—	Type	Size
------	---	------	------

Kit Components

Order Number	Components	Qty	Items
e.g SKit – MH006	Meter Body O-Ring	1	8

## Rotor Kit - (Type MH only)

Customer Model Number

MH	006	—	1	S	2
----	-----	---	---	---	---



Coding Sequence

RKit	—	Type	Size	—	S
------	---	------	------	---	---

Kit Components

Order Number	Components	Qty	Items
e.g RKit – MH006 – S	Complete Rotor Assembly	1 set	7
	Meter Body O-Rings	1	8
	Meter Cap Screws	4	2

## Wetted Parts

### Model 006

Component	Type 'F'	Type 'S'	Type 'M'	Type 'MH'	Type 'CR'
Meter Body	Al	Al	SS	SS	PPS
Meter Cap	Al	Al	SS	SS	PPS
Rotor Shafts	SS	SS	SS	SS	Hast C
Rotors - Standard	SS	SS	SS	SS	PPS
- High Temp.	-	-	SS	SS	-
Rotor Bushes	CA	CA	CA	CA	-
O-Ring	FKM	FFKM	FFKM	FFKM	FFKM

### Model 009

Component	Type 'F'	Type 'S'	Type 'M'	Type 'MH'	Type 'CR'
Meter Body	Al	Al	SS	SS	PPS
Meter Cap	Al	Al	SS	SS	PPS
Rotor Shafts	SS	SS	SS	SS	Hast C
Rotors - Standard	SS	SS	SS	SS	PPS
- High Temp.	-	-	SS	SS	-
- High Viscosity.	SS	SS	SS	SS	-
Rotor Bushes	CA	CA	CA	CA	-
O-Ring	FKM	FFKM	FFKM	FFKM	FFKM

K - FEP/PTFE Encapsulated

SS - Stainless Steel 316 /304

Al - Aluminium AA610

CA - Carbon

FKM - Viton ®

PPS - Polyphenylene Sulphide

PVDF - Polyvinylidene Flouride

FFKM - Perfluoro Elastomer

Hast C - Hastelloy C™

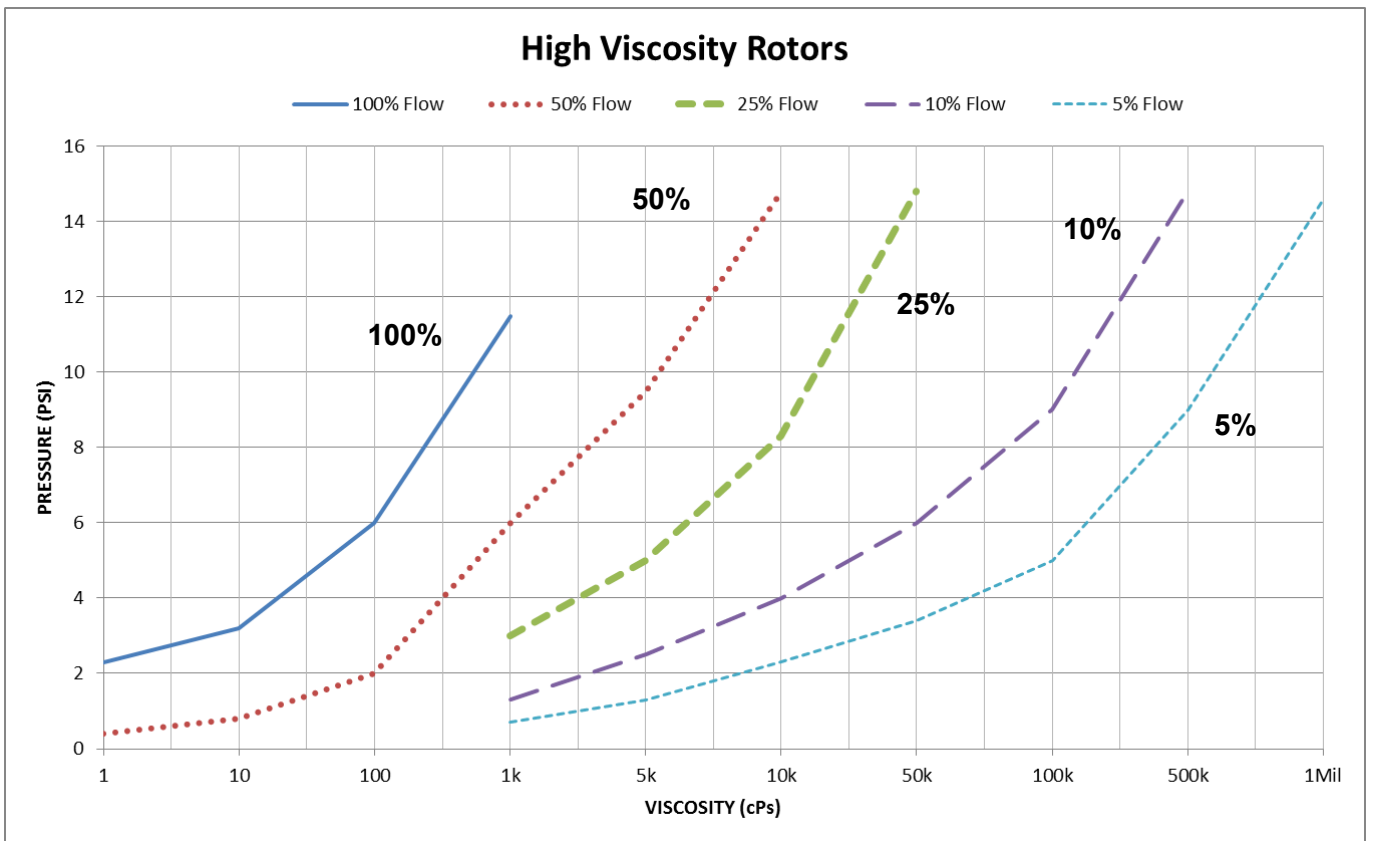
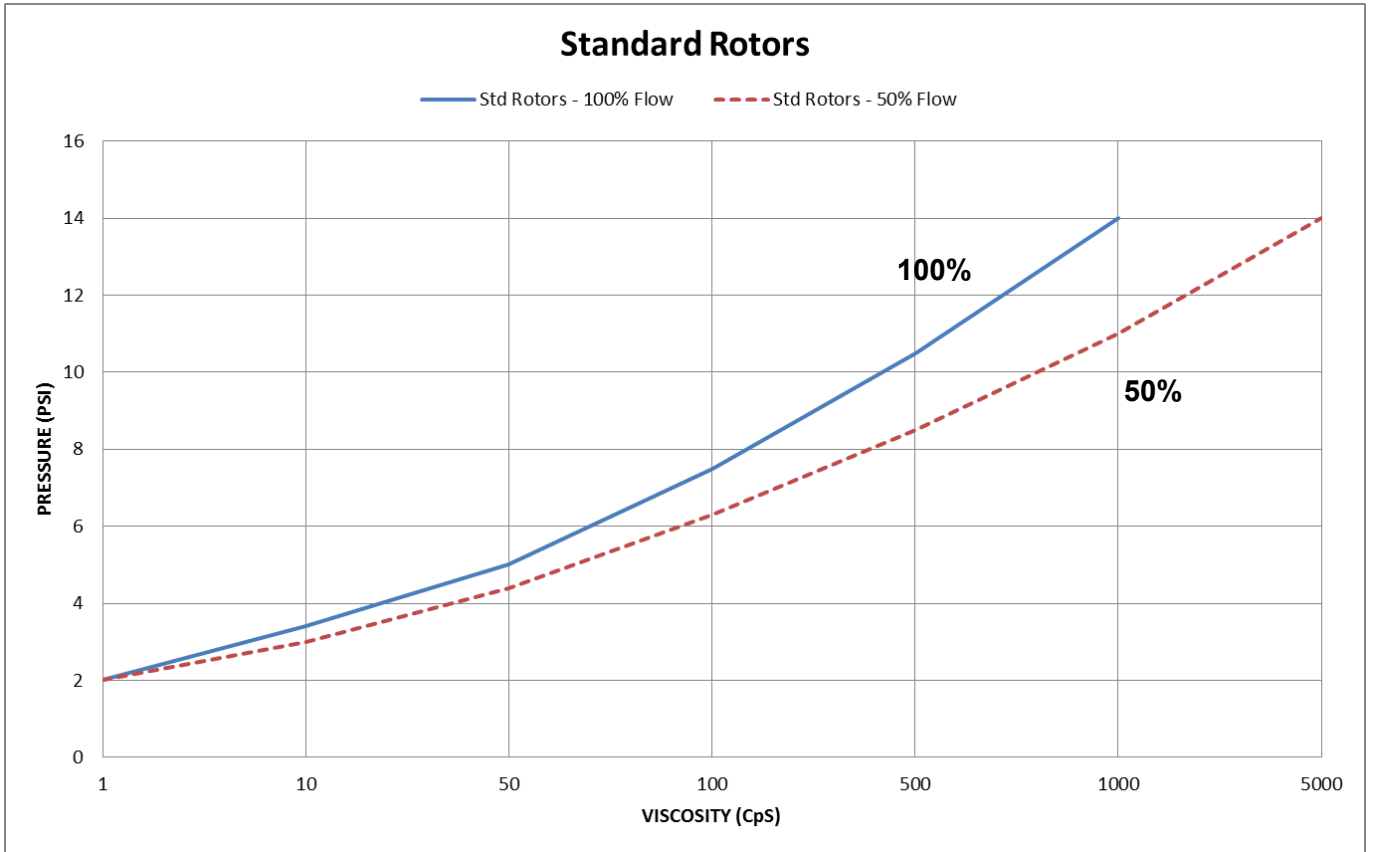

# Meter Dimensions

		A - Face to Face Length			B - Register Height				
		CR Series (Ryton)	F and S Series' (Al)	M Series (SS)	MH Series SS HP)	CR Series (Ryton)	F and S Series' (Al)	M Series (SS)	MH Series (SS HP)
RC/NPT		64	60	50	83	58	58.6	58.6	108
RP			60	50	83	100	100	100	126
	Pulse								
	DR								

Pulse

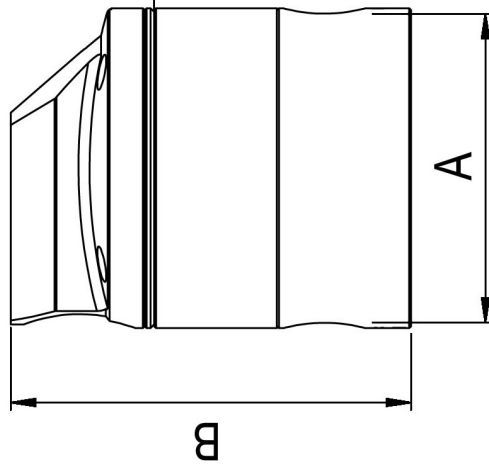

MH Series

DR

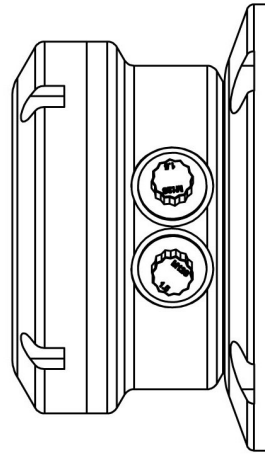

Pulse

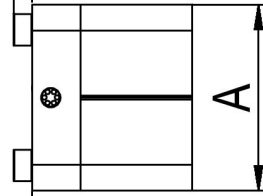

Pulse

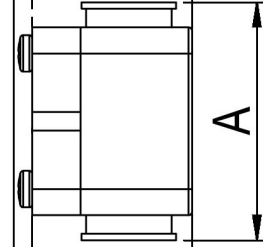

Pulse

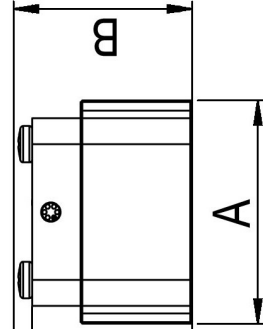

M Series CR Series F and S Series' F and S Series'









**WEEE Directive - Waste Electrical and Electronic Equipment**



The WEEE Directive requires the recycling of waste electrical and electronic equipment in the European Union.

Whilst the WEEE Directive does not apply to some of Macnaught's products, we support its policy and ask you to be aware of how to dispose of this product.

The crossed out wheeled bin symbol illustrated and found on our products signifies that this product should not be disposed of in general waste or landfill.

Please contact your local dealer national distributor or Macnaught Technical Services for information on product disposal.



**Macnaught Pty Limited**

ABN 66 000 075 785

41-49 Henderson Street  
Turrella NSW 2205 Sydney Australia  
Postal Address PO Box 90  
Amcliffe NSW 2205 Sydney Australia

**T:** +61 2 9567 0401

**F:** +61 2 9597 7773

**W:** [www.macnaught.com.au](http://www.macnaught.com.au)