

Technical Information

Memosens CPS31D and Ceratex CPS31

pH electrodes, analog and digital with Memosens technology

For drinking water and swimming pool water

Gel-filled reference system with ceramic diaphragm



Application

- Drinking water
- Swimming pool water
- pH compensation for measuring free chlorine

Your benefits

- One or three ceramic diaphragms
- Optional salt ring for extended operating life
- Very low level of ion depletion in electrolyte
- Gel filling, no electrolyte refill required
- Can be used up to 4 bar (60 psi) absolute pressure
- Can be used up to 80 °C (176 °F)
- Shaft length 120 mm
- Memosens plug-in head
- ESA or GSA plug-in head

Further benefits offered by Memosens technology

- Maximum process safety thanks to non-contact, inductive signal transmission
- Digital data transmission ensures data security
- Very easy to use as sensor-specific data are stored in the sensor
- Recording of sensor load data in the sensor enables predictive maintenance

Function and system design

Measuring principle	<p>pH measurement</p> <p>The pH value is a measure of the acid or base character of a medium. Depending on the pH value of the medium, the electrode's membrane glass provides an electrochemical potential. This is the result of H⁺ ions selectively penetrating the outer layer of the membrane. As a result, an electrochemical boundary layer forms here with an electric potential. An integrated Ag/AgCl reference system forms the required reference electrode.</p> <p>The transmitter converts the measured voltage into the corresponding pH value according to the Nernst equation.</p>
General characteristics	<p>Durability</p> <p>Depending on the version, the electrode can withstand pressures up to 4 bar (60 psi) and temperatures up to 80 °C (176 °F).</p>
Communication and data processing with CPS31D	<p>Measuring system data which digital sensors can save in the sensor include:</p> <ul style="list-style-type: none"> ■ Manufacturer data <ul style="list-style-type: none"> - Serial number - Order code - Date of manufacture ■ Calibration data <ul style="list-style-type: none"> - Date of calibration - Calibrated slope at 25 °C (77 °F) - Calibrated zero point at 25 °C (77 °F) - Temperature offset - Number of calibrations - Serial number of the transmitter used to perform the last calibration ■ Operating data <ul style="list-style-type: none"> - Temperature application range - pH application range - Date of initial commissioning - Maximum temperature value - Operating hours at temperatures above 80 °C / 100 °C (176 °F / 212 °F) - Operating hours for very low and very high pH values (Nernst voltage below -300 mV, above +300 mV) - Number of sterilizations - Glass membrane impedance <p>The data listed above can be displayed using the Mycom S CPM153, Liquiline M CM42 and Liquiline CM44x transmitters.</p>
Dependability with CPS31D	<p>Reliability</p> <p>Memosens technology digitizes the measured values in the sensor and transmits them to the transmitter via a non-contact connection in a way that is free from any potential interference. The result:</p> <ul style="list-style-type: none"> ■ Automatic error message generation if the sensor fails or the connection between sensor and transmitter is interrupted ■ Immediate error detection increases measuring point availability

Maintainability

Sensors with Memosens technology have integrated electronics that save calibration data and other information, such as total hours of operation and operating hours under extreme measuring conditions etc. Once the sensor has been connected, the sensor data are automatically sent to the transmitter and used to calculate the current measured value.

Saving the calibration data makes it possible to calibrate and adjust the sensor irrespective of the measuring point. The result:

- Convenient calibration in the measuring lab under optimum external conditions improves the quality of the calibration.
- Measuring point availability is dramatically increased by the quick and easy replacement of precalibrated sensors.
- The availability of the sensor data makes it possible to accurately determine the maintenance intervals of the measuring point and enables predictive maintenance.
- The sensor history can be documented using external storage media and evaluation programs. The sensor's field of application can be determined based on its previous history.

Integrity

With its inductive transmission of the measured value via a non-contact plug-in connection, Memosens guarantees maximum process safety and offers the following advantages:

- All problems caused by moisture are eliminated:
 - The plug-in connection is free from corrosion
 - Moisture cannot corrupt the measured value
 - Plug-in system can even be connected under water
- The transmitter is galvanically decoupled from the medium.
- EMC safety is guaranteed by screening measures in the digital measured value transmission.

Measuring system

A complete measuring system comprises:

- pH electrode CPS31D or CPS31
- Transmitter, e.g. Liquiline CM44x (for CPS31D with Memosens technology)
- Measuring cable, e.g. CYK10 for CPS31D
- Immersion, flow or retractable assembly, e.g. Flowfit CCA250

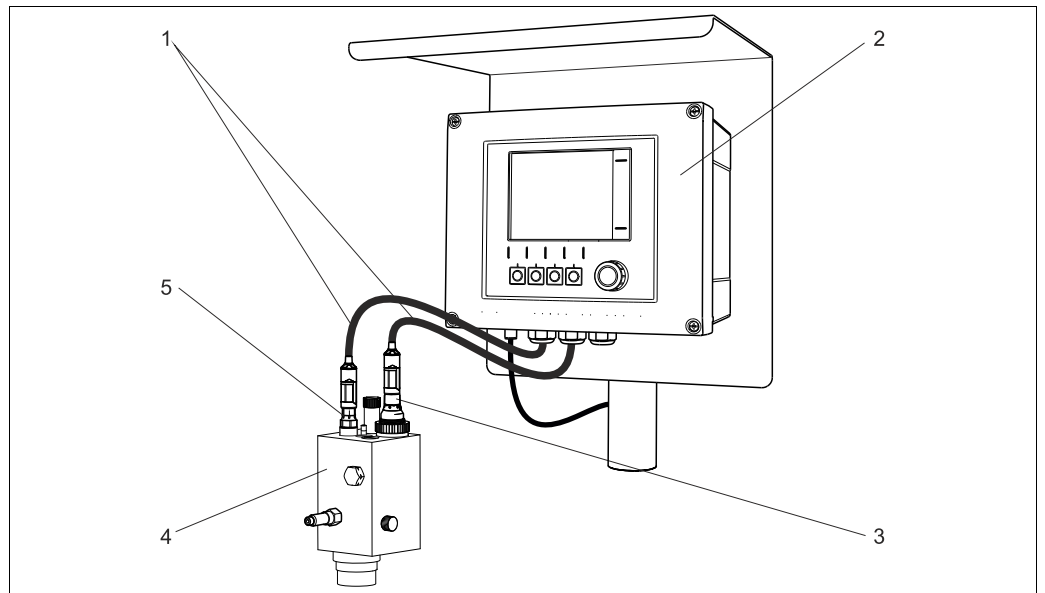

Example of a measuring system: pH compensation for chlorine measurement

- 1 Cable CYK10
- 2 Liquiline CM44x transmitter
- 3 Chlorine sensor CCS142D
- 4 Flowfit assembly CCA250
- 5 pH electrode CPS31D

Input

Measured variables	pH value Temperature
Measuring range	pH: 1 to 12 Temperature: 0 to 80 °C (32 to 176 °F)

Installation

Installation instructions

Do not install the electrodes upside down. The inclination angle must be at least 15° from the horizontal. A smaller inclination angle is not permitted as it could cause an air bubble to form in the glass sphere and prevent the inner electrolyte from completely wetting the pH membrane.

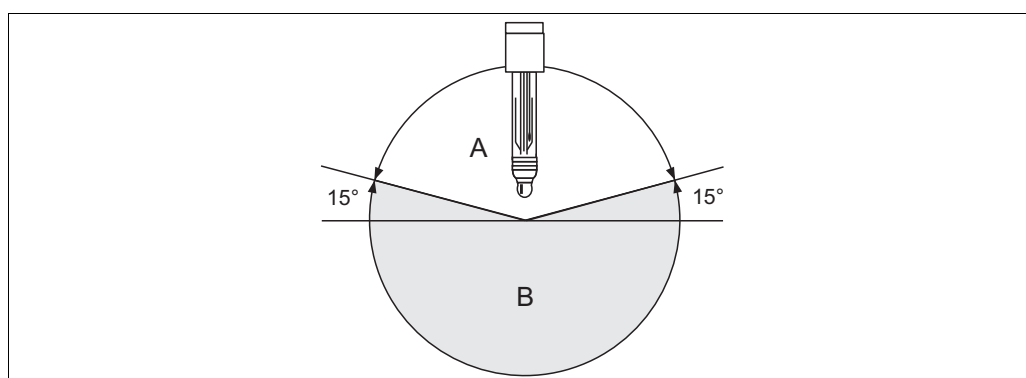

Electrode installation; angle at least 15° from the horizontal

A Permitted orientation
B Incorrect orientation

NOTICE

Before screwing in the electrode, make sure the threaded connection of the assembly is clean and runs smoothly.

- ▶ Hand tighten the electrode (3 Nm)! (Information valid only when installing with Endress+Hauser assemblies.)
- ▶ Also pay attention to the installation instructions provided in the Operating Instructions of the assembly used.

Environment

Ambient temperature range

NOTICE
Risk of damage due to frost

- ▶ The sensor must not be used at temperatures below -15 °C (5 °F).

Storage temperature

0 to 50 °C (32 to 120 °F)

Degree of protection

IP 67: GSA plug-in head (with closed connector system)
 IP 68: ESA plug-in head (1 m (3.3 ft) water column, 50 °C (120 °F), 168 h)
 IP 68: Memosens plug-in head (10 m (33 ft) water column, 25 °C (77 °F), 45 days, 1 M KCl)

Process

Process temperature range

0 to 80 °C (32 to 176 °F)

Process pressure (absolute)

1 to 4 bar (15 to 60 psi)

CAUTION
Sensor is exposed to pressure when used for longer periods under increased process pressure
Risk of injury due to glass breakage

- ▶ Do not apply too much heat to sensors of this type if they are being used under reduced process pressure or under atmospheric pressure.
- ▶ Wear protective goggles and suitable gloves when handling this type of sensor.

Pressure-temperature load

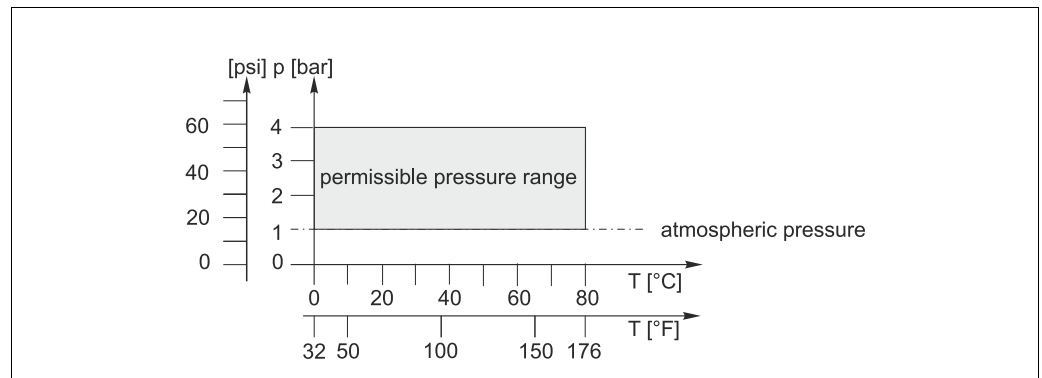

A0019521-EN

Pressure-temperature load

Minimum conductivity

100 $\mu\text{S/cm}$
 50 $\mu\text{S/cm}$ for "AC" version (three diaphragms)

Mechanical construction

Design, dimensions CPS31

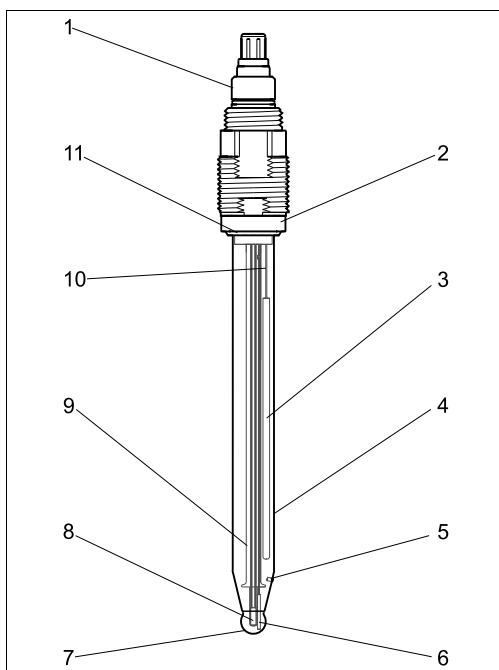

CPS31 with ESA plug-in head

- 1 ESA electrode plug-in head, Pg 13.5
- 2 Pressure ring
- 3 Capillaries
- 4 Shaft tube
- 5 Diaphragm
- 6 Ag/AgCl internal reference lead

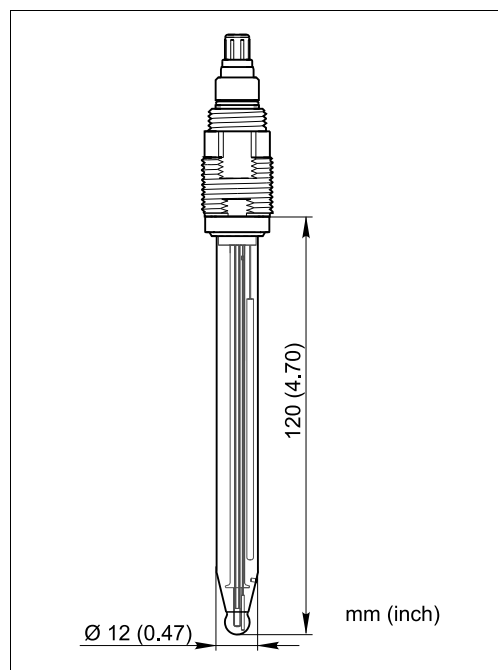

CPS31 with ESA plug-in head

- 7 pH membrane glass
- 8 Temperature probe
- 9 Internal tube
- 10 Leads, external
- 11 O-ring

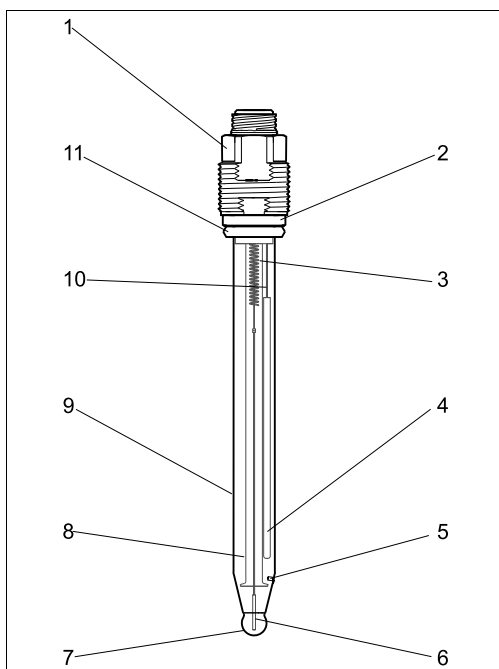

CPS31 with GSA plug-in head

- 1 GSA electrode plug-in head, Pg 13.5
- 2 Pressure ring
- 3 Compression spring
- 4 Capillaries
- 5 Diaphragm
- 6 Ag/AgCl internal reference lead

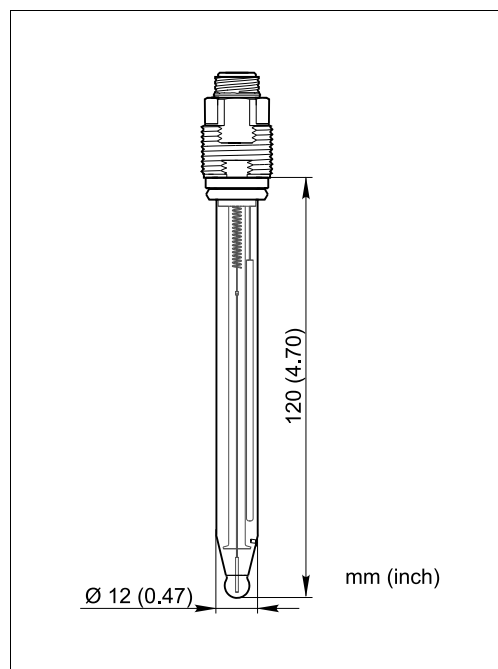

CPS31 with GSA plug-in head

- 7 pH membrane glass
- 8 Internal tube
- 9 Shaft tube
- 10 Lead, external
- 11 O-ring

Design, dimensions CPS31D

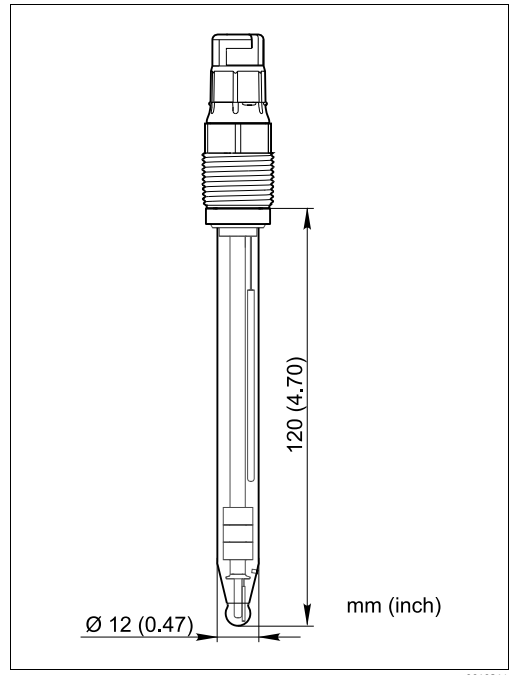
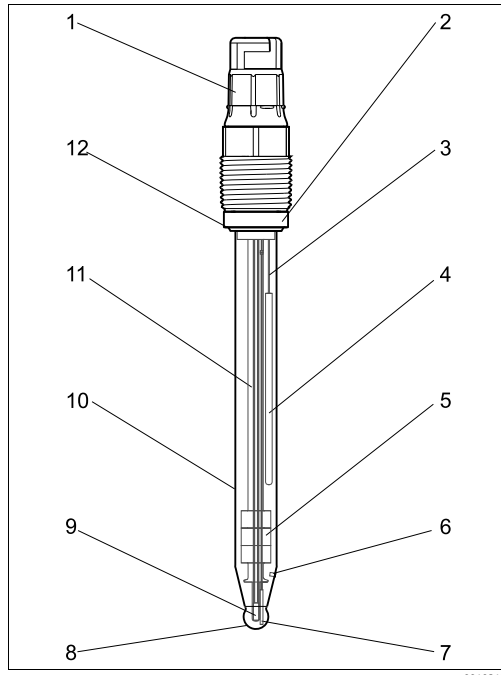

CPS31D

- 1 Memosens plug-in head
- 2 Pressure ring
- 3 Lead, external
- 4 Capillaries
- 5 Salt rings (optional)
- 6 Diaphragm

CPS31D

- 7 Ag/AgCl internal reference lead
- 8 pH membrane glass
- 9 Temperature probe
- 10 Shaft tube
- 11 Internal tube with leads
- 12 O-ring

Weight	0.1 kg (0.22 lbs)	
Materials	Electrode shaft pH membrane glass Metal lead Diaphragm	Glass Type A Ag/AgCl Ceramic
Process connection	Pg 13.5	
Temperature sensor	CPS31D: CPS31:	NTC 30K Pt 100
Plug-in heads	CPS31D: CPS31:	Memosens plug-in head for digital, non-contact data transmission ESA, GSA
Reference system	Ag/AgCl, gel, 3M KCl Optional: Salt ring, KCl-saturated	

Certificates and approvals

TÜV certificate ESA and Memosens plug-in head

Pressure resistance 16 bar (232 psi), minimum three times the safety pressure

Electromagnetic compatibility of CPS31D

Interference emission and interference immunity as per EN 61326: 2006

Ordering information

Product pages

You can create a valid and complete order code on the Internet with the Configurator tool.

Enter the following addresses in the browser to access the relevant product page:

www.products.endress.com/cps31

www.products.endress.com/cps31d

Product Configurator

1. You can find the following options on the right-hand side of the product page:

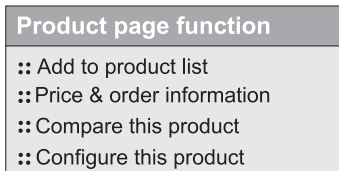

2. Click "Configure this product".

3. The Configurator opens in a separate window. You can now configure your device and receive the complete and valid order code.

4. Now export the order code as a PDF or Excel file. To do so, click the corresponding button at the top of the page.

Accessories

Assemblies (selection)

Cleanfit CPA472

- Compact plastic retractable assembly for installation in tanks and pipes, for manual or pneumatically remote-controlled operation
- Order according to product structure (--> Online Configurator, www.products.endress.com/cpa472)
- Technical Information TI00223C/07/EN

Cleanfit CPA475

- Retractable assembly for installation in tanks and pipes under sterile conditions
- Order according to product structure (--> Online Configurator, www.products.endress.com/cpa475)
- Technical Information TI00240/C/07/EN

Unifit CPA442

- Installation assembly for food, biotechnology and pharmaceuticals, with EHEDG and 3A certificate,
- Order according to product structure (--> Online Configurator, www.products.endress.com/cpa442)
- Technical Information TI00306/C/07/EN

Dipfit CPA111

- Immersion and installation assembly for open and closed containers
- Order according to product structure (--> Online Configurator, www.products.endress.com/cpa111)
- Technical Information TI00112C/07/EN

Flowfit CPA250

- Flow assembly for pipe installation of pH/ORP sensors with Pg 13.5 and 120 mm (4.72") installation length
- Order according to product structure (--> Online Configurator, www.products.endress.com/cpa250)
- Technical Information TI00041C/07/EN

Ecofit CPA640

- Adapter for 120 mm pH sensors
 - Order according to product structure (--> Online Configurator, www.products.endress.com/cpa640)
 - Technical Information TI00264C/07/EN
-

Buffer solutions

High quality buffer solutions of Endress+Hauser - CPY20

Solutions which are traced by a DAkkS-accredited Endress+Hauser buffer laboratory (DkkS = German Accreditation Body) to a primary reference material of the PTB and to standard reference material of the National Institute of Standards and Technology (NIST) in accordance with DIN 19266 are used as secondary reference buffer solutions.

- Order according to product structure (-> Online Configurator, www.products.endress.com/cpy20)
-

Measuring cable

Memosens data cable CYK10

- For digital sensors with Memosens technology
- Order according to product structure (--> Online Configurator, www.products.endress.com/cyk10)
- Technical Information TI00118C/07/EN

Measuring cable CPK9

- For sensors with ESA plug-in head, for high-temperature and high-pressure applications, IP 68
- Order as per product structure
- Technical Information TI00501C/07/EN

Special measuring cable CPK1

- For pH/ORP electrodes with GSA plug-in head
- Order as per product structure
- Technical Information TI00501C/07/EN

www.addresses.endress.com
