

Model CPB3500 Pneumatic Dead-Weight Tester

Operating and Maintenance Instructions

Copyright © DH-Budenberg

No part of this document may be reproduced or translated, in any form, electronic or otherwise

Without prior written consent of DH-Budenberg

**DH-Budenberg wil notl be liable for incidental or consequential
damage in connection with the use of this document.**

**DH-Budenberg Ltd reserve the right to change the contents form of this manual at any time without prior
notice having been given.**

**This product must only be used for the express purpose as advertised by DH-Budenberg and as referred
to in this and other DH-Budenberg approved literature**

Contents

SECTION	TITLE	PAGE
	SAFETY PRECAUTIONS	4
	Air/gas supply	4
	Lifting of weights	4
	Mineral oils Health & Safety (C.O.S.H.H.) Information	4
1	DATA SHEET	5
1.1	Tester Dimensions	5
1.2	Pressure ranges	5
1.3	Liquids used	5
2	DESCRIPTION	6
2.1	General	6
2.2	CPB3500 Series base unit	7
2.3	CPS3500 Piston unit:0.15 – 1bar	8
2.4	CPS3500 Piston unit:0.1 – 7 bar	8
2.5	CPS3500 Piston unit:0.2 – 25 bar	8
2.6	CPS3500 Piston unit: 1 – 70 bar and 1 - 120 bar	8
2.7	Functional	10
3	INSTALLATION	11
3.1	Unpacking the tester	11
3.2	Environmental requirements	11
3.3	Assembly of base units	11
3.4	Packing list	12
4	OPERATING INSTRUCTIONS	16
4.1	Procedure	16
4.2	Completion	16
4.3	Cleaning gauges	18
4.4	Temperature measurement of piston units	20
5	FAULT FINDING	21
6	PERIODIC MAINTENANCE	22
6.1	Cleaning the unit	22
7	CORRECTIVE MAINTENANCE	23
7.1	General	23
7.2	Removing cover	23
7.3	Valve seals	23
7.4	Supply/Release valve testing procedure	23
7.5	Volume adjuster	23
7.6	System Gauge indicator	24
7.7	Piston/Cylinder unit	24
7.8	Overhaul and Re-certification	24
8	SPARE PARTS	26
8.1	Spare parts list	26
8.2	Ordering spares	26
8.3	Spare seal identification chart	29
9	OPTIONAL EXTRAS	30
9.1	Model 24 vacuum adaptor	30
9.2	Model 27 gauge stand	30
9.3	Model 35 Air/Liquid interface	30
9.4	Fine increment weights	30
9.5	UKAS certificate of calibration	30

Safety Precautions

AIR/GAS SUPPLY

The CPB3500 series range of dead-weight testers requires a regulated supply of clean dry gas to operate. Any compressed pneumatic source represents a source of considerable potential energy and as with electricity, precautions must be taken to prevent accidents.

Before connecting/disconnecting instruments under test the operator should ensure no pressure is present in the system.

Before connecting/disconnecting the tester from its pressure source the operator should ensure that the pressure source is isolated from the tester. We recommend using a Nitrogen Cylinder as the gas from this is normally dry and clean. Alternatively use compressed air, filtered and dried to remove oil and moisture which could cause the piston or the tester to become sticky. Fit a reducing valve to reduce pressure to just above the maximum pressure at which the tester is to be used.

This tester **IS NOT** suitable to calibrate **oxygen** gauges the air/gas must be **completely oil-free for safety**. Do not use oxygen in the tester. Calibrate only oil-free gauges to avoid contamination of the tester.

If no suitable supply is available use a hand pump for pressures or vacuum use

LIFTING OF WEIGHTS

Care must be taken when lifting weights for the dead weight tester. Each weight must be lifted individually and never attempt to lift stacks of weights on or off the tester.

MINERAL OILS HEALTH AND SAFETY (C.O.S.H.H.) INFORMATION

DH-Budenberg provide hydraulic mineral oil in 500 ml containers labeled "ISO VG 22" for use on CPS3500 Piston unit: 1 to 120 bar dead-weight testers. It is no more hazardous than other common lubricating oils.

It is the nature of the way in which this equipment is used, that there could be frequent and/or prolonged skin contact; in a few individuals this could give rise to skin irritation (Keratosis or Dermatitis). The use of an effective barrier cream will greatly reduce this possibility.

DESCRIPTION

Closed flash point:	greater than 120°C
Storage:	not above 30°C
Oral LD 50:	15 g per kg body weight
Threshold limit value:	5 mg/m ³ .
Fire extinguishing media:	carbon dioxide/dry chemical foam or water fog
Spillage:	soak with absorbent clay or proprietary absorbent
Waste disposal:	burn or dump in approved area.

EMERGENCY TREATMENT OF ACUTE EFFECTS

Ingestion:	Do not induce vomiting. Administer 250 ml milk or olive oil. The main hazard following accidental ingestion is aspiration of liquid into the lungs.
Aspiration:	Send to hospital immediately
Inhalation:	Remove to fresh air, if nausea persists seek medical attention.
Eye contact:	Wash with copious amounts of water for at least 10 minutes. If irritation results or persists, obtain medical advice.
Skin Contact:	Where skin rashes or other abnormalities occur as a result or prolonged or repeated contact, medical advice should be obtained as soon as possible.

OTHER LIQUIDS

For some very particular applications we supply specially constructed liquids. Copies of manufacturer's data will be sent to users on request.

Data Sheet

1.1 TESTER DIMENSIONS

WIDTH	= 400mm
DEPTH	= 360 mm
HEIGHT (Without Piston/Cylinder unit)	= 210 mm
HEIGHT With CPB3500 Piston/Cylinder (-1 to 1 bar)	= 210 mm
HEIGHT With CPB3500 Piston/Cylinder (0.1 to 7 bar)	= 225 mm
HEIGHT With CPB3500 Piston/Cylinder (0.2 to 25 bar)	= 210 mm
HEIGHT With CPB3500 Piston/Cylinder (1 to 120 bar)	= 240 mm
Weight of base	= 17 kg

1.2 PRESSURE RANGES

CPS3500 Piston unit	15 to 1000 mbar (pure gas)
(vac operation with Model 24)	-1000mbar to - 15mbar #
CPS3500 Piston unit	0.1 to 7.0 bar (pure gas)
CPS3500 Piston unit	0.2 to 25 bar (pure gas)
CPS3500 Piston unit	1.0 to 120 bar (oil lubricated, gas operated)
CPP120-X Comparator	vac to 120 bar (pure gas)

Maximum negative gauge pressure is dependent on atmospheric pressure.

1.3 OILS SUITABLE FOR TESTER - (Model CPS3500: 1 – 120 bar Only)

The CPS3500 piston unit is an oil lubricated re-entrant type Piston/Cylinder unit with air pressure applied to the surface oil. The following oils are commercially available oils suitable for use with the Piston/Cylinder unit.

ISO 3448 viscosity grade	Approx. SAE viscosity classification	Shell	Esso	Mobil
VG22	10W	Tellus 22	Nuto H22	DTE 22
VG32		Tellus R22	Nuto H32	DTE Oil Light
VG37		Tellus V32		
		DTE 24		
		Tellus 37		
		Tellus R37		
		Tellus T37		
		Tellus V37		

OTHER LIQUIDS

An inert fluorinated fluid (such as Halocarbon*, Fomblin* or Fluorolube*) may alternatively be used with a CPS3500 Piston/Cylinder unit to prevent any contamination of gas by hydrocarbon vapor.

WARNING

NO LIQUID SHOULD EVER BE POURED INTO THE MODEL 550 BASE AS THIS WOULD CONTAMINATE THE UNIT RENDERING IT UNSUITABLE FOR CALIBRATION PURPOSES.

* HALOCARBON, Trade Mark of Halocarbon Products Corp.

* FOMBLIN, Trade Mark of Montedison

* FLUOROLUBE, Trade Mark of Hooker Chemical Corp.

Description

2.1 GENERAL

The CPB3500 series dead-weight tester can be supplied in several different configurations. The series is based around the CPB3500 base unit which is common to all the different configurations. The base unit provides a pressure source, volume adjuster, control valves, system indicating gauge and gauge or piston connections. When the base unit is used with one of the CPS3500 piston units the configuration provides a high accuracy dead-weight tester. When the base unit is used in the CPP120-X configuration with a high accuracy standard test gauge, it provides a simple to use comparator.

In the dead-weight tester configuration the selected piston unit is normally screwed onto the left hand side pressure block of the base unit and the gauge under test is connected to the right hand pressure block of the base unit. In the comparator configuration a reference gauge is normally connected to the left hand side pressure block of the base unit and the gauge under test is connected to the right hand pressure block of the base unit. The pressure datum of the tester is marked on the piston units.

Any CPP120-X comparator can be converted to any dead-weight tester by the addition of the appropriate piston/cylinder unit and weights and any dead-weight tester can be converted to a CPP120-X comparator with the addition of an extra gauge stand.

General View of CPB3500 series

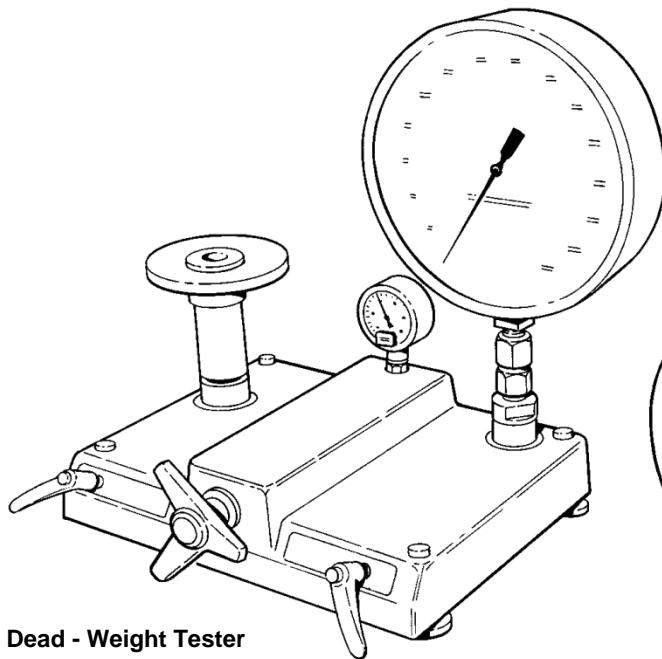

Dead - Weight Tester

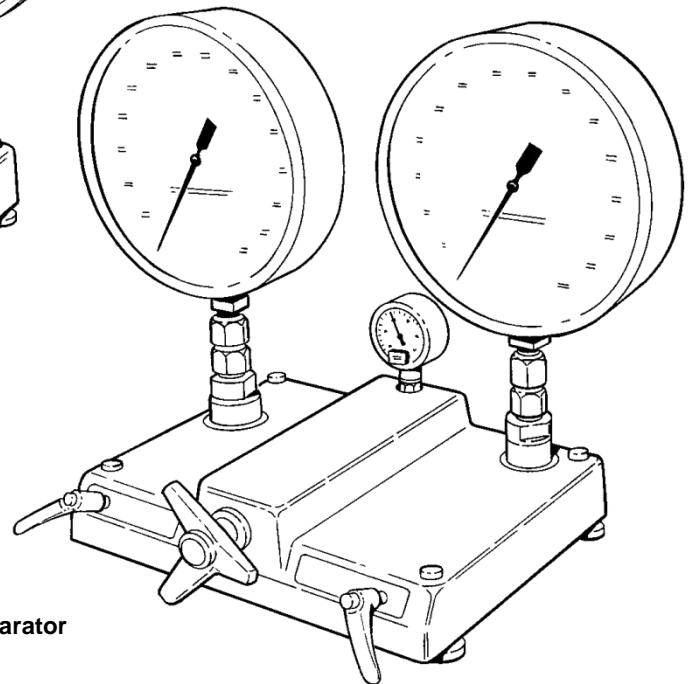

Comparator

2.2 CPB3500 SERIES BASE UNIT

The CPB3500 series base unit consists of a solid aluminium base plate mounted on four adjustable leveling feet, pressure inlet manifold with system pressure gauge, supply/vent control valves, volume adjuster and pipe work to two stainless steel pressure connection blocks. The pipework is covered by an easy to clean ABS moulded cover.

INLET MANIFOLD

The inlet manifold is bolted to the rear of the aluminium base plate. The external pressure source should be connected here.

SYSTEM PRESSURE GAUGE

The system pressure gauge gives an indication only of the approximate pressure which is in the system. This gauge is not intended for calibrating other instruments.

CONTROL VALVES

Two control valves are provided at the front of the tester base. The valves control the supply and release of pressure into the tester base.

THE VALVES ARE OF A 'SOFT SEAT' DESIGN AND SHOULD ONLY REQUIRE TO BE FINGER TIGHT TO ACHIEVE AN EFFECTIVE SEAL. OVERTIGHTENING OF THE VALVE WILL RESULT IN A SHORTER WORKING LIFE & THUS INVOLVE MAINTENANCE.

VOLUME ADJUSTER

A volume adjuster is provided to achieve fast and accurate adjustment of small changes in pressure which are required when calibrating high accuracy instruments.

CONNECTION BLOCK

Pressure supply pipes from the volume adjuster are terminated at two pressure blocks mounted on the base unit. The pressure blocks are fitted with internal thread bosses projecting up through the cover of the base unit. These threaded bosses enable piston units to be directly screwed onto them, or union connections for various sizes of gauge connections to be screwed on them.

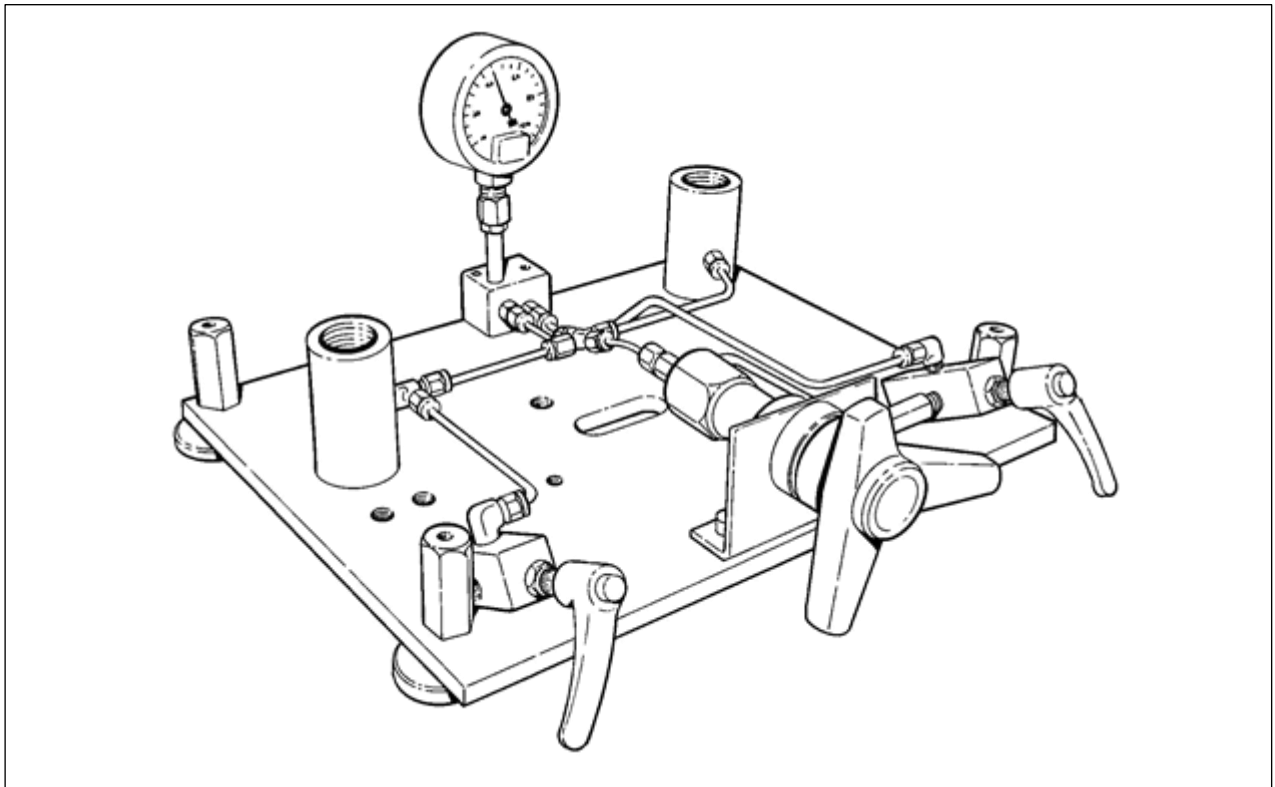

2.3 CPS3500 Piston unit: 0.015 to 1.0 bar (pure gas)

The piston unit is a simple rugged single range piston unit which covers a vacuum range from - 1000 mbar to - 15 mbar (when connected to a vacuum pump and a Model 24 [see section 9.2]) and pressure ranges from 15 mbar to 1000 mbar.

The cylinder for the piston unit screws directly onto the base unit pressure connection. The piston head carries the calibration weights and is fitted to the end of the piston. An integral stop is machined into the piston which abuts the internal end of the cylinder when the maximum piston extension is reached. The pressure datum level of the piston unit is a grooved ring on the outside of the piston/cylinder assembly.

Very low pressure can be attained with this piston unit which makes it especially useful for calibrating differential pressure transmitters and vacuum instruments.

2.4 CPS3500 Piston unit: 0.1 to 7.0 bar (pure gas)

The piston unit is a similar piston unit to the CPS3500:0.015 to 1.0 bar unit, except it covers the pressure range 0.1 to 7.0 bar.

2.5 CPS3500 Piston unit: 0.2 to 25 bar (pure gas)

The piston unit is a single ranged piston unit which covers the pressure range 0.2 to 25 bar. The tungsten carbide measuring cylinder for the piston unit is fitted into a housing which screws directly onto the base unit pressure connection.

The piston head carries an overhung calibration weight. The larger annular weights fit over the skirt of the overhang, which gives the advantage of better spin times. Smaller weights fit on top of the overhung weight. A bearing is fitted to the piston/cylinder housing which takes up forces due to under pressure or over pressure.

The pressure datum level of the piston unit is a grooved ring on the adaptor which the piston/cylinder is assembled to.

This piston/cylinder unit covers a wide pressure range. The weights are smaller and easier to handle than those of a CPS3500:0.1 to 7.0 at overlapping pressure.

2.6 CPS3500 Piston unit: 1 to 70, 1 to 120 bar (oil lubricated, gas operated)

The oil lubricated piston unit is a rugged design of piston unit which cover the pressure range of 1 to 120 bar.

The measuring cylinder for the piston unit is fitted into a housing which screws directly onto the base unit pressure connection.

The piston head carries the calibration weights and is fitted to the end of the piston. A stop is fitted to the piston which abuts the internal end of the cylinder when the piston reaches the end of its stroke. The pressure datum level of the piston unit is a grooved ring on the outside of the piston/cylinder assembly.

The piston/cylinder operates by applying air pressure to the surface oil contained in the piston/cylinder housing. (See section 4 for details of operation).

CPS3500 Piston Cylinder Units



CPS3500: 0.015 – 1 bar



CPS3500: 0.1 – 7 bar



CPS3500: 0.2 – 25 bar



CPS3500: 1 – 70 bar and 1 – 120 bar

2.7 FUNCTIONAL

Operation of the tester is by controlling the supply/release of a pneumatic pressure/vacuum source by the supply valve and the vent valve. With the use of the control valves (and if applicable the system pressure gauge) the operator can approximately reach the pressure they require.

To achieve the exact pressure required the volume adjuster should be rotated clockwise/anti-clockwise to increase/decrease pressure. Excessive force is not required on the control valves and or volume adjuster to achieve the desired results. To release the test pressure the vent valve is opened.

Schematic Diagram

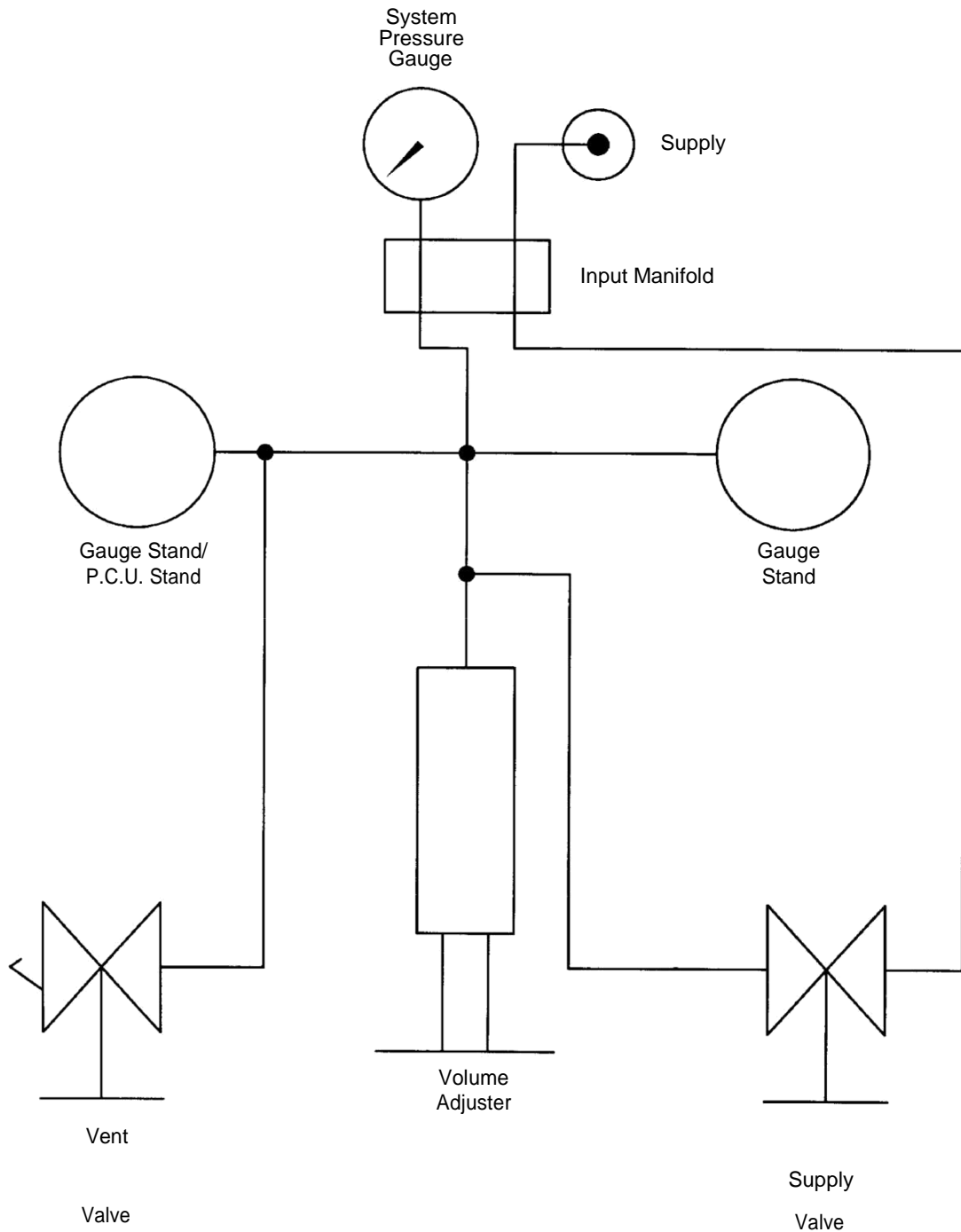

Installation

3.1 UNPACKING THE TESTER

As soon as possible after delivery open the packaging of the dead-weight tester and check that you have all the items detailed for your tester in the packing list detailed in section 3.4.

As you are unpacking the items examine the items for signs of damage or breakage during transit.

If any items are missing get in touch immediately with DH-Budenberg to inform us of the shortage.

3.2 ENVIRONMENTAL REQUIREMENTS

When siting the tester, if not in a temperature controlled laboratory, look for an area that satisfies the following criteria as much as possible

- a constant temperature area free from draughts and sources of heat or cold
- an area free from noise and vibration; if possible an area away from any constantly used pathways
- A clean dry area free from corrosive liquids or vapors.

A strong, stable, level table or workbench is required with the capability of supporting the tester plus a full load of test weights and with sufficient space to operate the test unit.

3.3 ASSEMBLY OF BASE UNITS

Fastening base to bench

The base is to be mounted on a firm, level table or bench about 0.9 m high. Space is normally required for storing the weights on the left hand side of the bench. The centre line of the front adjustable feet of the unit should be about 40 mm from the front edge of the bench to allow adequate clearance for the handwheel.

- (1) Mark the position of the adjustable feet of the unit on the top of the bench.
- (2) Position a level plate at the centre of each of the adjustable feet of the unit and screw the plate to the bench to ensure that the tester is rigid.
- (3) Fit the base unit on the bench with the adjustable feet on the level plates and the handwheel projecting over the front of the bench.
- (4) Using the spirit level provided level the unit in both the front/rear axis and the side to side axis by adjusting the four knurled feet. If a piston unit is to be fitted the levelling procedure should be carried out after the piston unit has been fitted to the dead-weight tester and the spirit level should be placed on the weight carrier during the levelling procedure.

3.4 PACKING LIST

A full packing list for all Models of testers is detailed below.

FOR ALL MODELS

The tester carton should contain:-

- 1 - copy of the operating and maintenance instructions
- 1 - 550 Series base
- 1 – USB device with manuals/data sheets loaded
- 1 - Tool roll containing:-
 - 1 - Hexagon wrench key 2 mm A/F
 - 1 - Hexagon wrench key 3 mm A/F
 - 2 - 30 mm A/F open ended spanners
 - 1 - Spirit level
 - 4 - Level plates
 - 1 - Bag of seals
 - 1 - G1/2 (1/2" B.S.P.) angle connection (If ordered separately)
 - 1 - Pointer punch
 - 1 - Pointer remover
 - 1 - Inlet manifold adaptor
 - 1 - Set of connections as ordered

B.S.P	N.P.T.	METRIC
1 - G 1/8*	1 - 1/8 in*	1 - M12 X 1.5
1 - G 1/4	1 - 1/4 in	1 - M20 X 1.5
1 - G 3/8	1 - 3/8 in	
1 - G 1/2	1 - 1/2 in	

* If ordered separately

FOR MODEL cpp120-X ONLY

- 2 - Gauge Stands
- 1 - Standard gauge (if ordered separately)

FOR MODEL CPS3500: 1 to 120 bar ONLY

- 1 - Gauge stand
- 1 - 500 ml bottle of oil
- 1 - Piston/Cylinder unit (as specified in your order)
- 1 - Set of weights supplied in separate carton
- 1 - Certificate of accuracy

FOR ALL OTHER MODELS

- 1 - Gauge stand
- 1 - Piston/Cylinder unit (as specified in your order)
- 1 - Set of weights
- 1 - Certificate of accuracy (not model CPP120-X)

SET OF WEIGHTS SUPPLIED FOR DEAD-WEIGHT TESTERS

1)	CPS3500: 0.015 to 1 bar	mbar (mm water x 10)	in. water
	Area = 1/2 in ² Range 15 mbar to 1000 mbar or 5 - 400 in. water (Ranges apply for vacuum use also)	6 x 100 6 x 50 3 x 20 2 x 10 1 x 5 make up weight to 15	2 x 100 2 x 50 1 x 45 2 x 20 1 x 10 1 x 5 2 x 2 1 x 1 make up weight to 5
	CPS3500: 0.015 to 2 bar	mbar (mm water x 10)	in. water
	All details as above plus additional weight	1 x 100	1 x 400
	CPS3500: 0.1 to 7 bar	bar (kg/cm ²)	lb/in ²
	Area = 1/2 in ² Range 0.1 to 7 bar or 1 to 100 lb/in ²	5 x 1 2 x 0.5 1 x 0.4 2 x 0.2 1 x 0.1 1 x 0.05 make up weight to 0.1	8 x 10 2 x 5 1 x 4 2 x 2 1 x 1 1 x 0.5 make up to piston 1
	CPS3500: 0.2 to 25 bar	bar (kg/cm ²)	lb/in ²
	Area = 1/8 in ² Range 0.2 to 25 bar or 3 to 400 lb/in ²	3 x 5 1 x 4.5 2 x 2 1 x 1 1 x 0.5 *1 x 0.3 make up weight to 0.2	2 x 100 1 x 90 1 x 50 2 x 20 1 x 10 1 x 5 *1 x 7 make up weight to 3
	*Over hang weight		
	CPS3500: 1 to 70 bar	bar (kg/cm ²)	lb/in ²
	Area = 1/16 in ² Range 1 to 70 bar or 10 to 1000 lb/in ²	2 x 20 1 x 18 1 x 10 2 x 4 1 x 2 2 x 1 1 x 0.5 make up weight to 1	3 x 200 1 x 180 1 x 100 2 x 40 1 x 20 2 x 10 1 x 5 piston 10
	CPS3500: 1 to 120 bar	bar (kg/cm ²)	lb/in ²
	Area = 1/16 in ² Range 1 to 120 bar or 10 to 1600 lb/in ²	4 x 20 1 x 18 1 x 10 2 x 4 1 x 2 2 x 1 1 x 0.5 make up weight to 1	6 x 200 1 x 180 1 x 100 2 x 40 1 x 20 2 x 10 1 x 5 piston 10

WEIGHT SET CAN BE PROVIDED IN ALTERNATIVE PRESSURE UNITS AND MANUFACTURED FOR LOCAL GRAVITY (GRAVITY VALUE IN m/s² UNIT TO 5 DECIMAL PLACES ONLY)
CONSULT YOUR LOCAL WIKA OFFICE FOR ADVICE ON AVAILABILITY

ASSEMBLY OF THE DEAD-WEIGHT TESTER

- (1) Fit appropriate piston unit for the gauges to be calibrated to the left hand connection and the gauge stand to the right hand connection. Ensure that the mating faces are absolutely clean and the 25 mm diameter 'O' ring seals are correctly located. Excess force is not required.
- (2) Check the level of the tester with the spirit level on the piston unit weight carrier. Level if necessary by using the levelling screws.
- (3) Fit the appropriate connection to the gauge stand, using a bonded seal to make the joint and screw a test gauge (for installation use a known gauge) into position, also with a bonded seal. If preferred, a copper or leather washer can be substituted for the bonded seal at the gauge. The loose nut on the tester base enables the gauge to be positioned as required and for back connection gauges the angle connection is screwed into the loose connection.

ASSEMBLY OF THE CPP120-X UNIT

- (1) Install the Model CPP120-X series base unit as detailed above.
- (2) Screw in place the two gauge stands.
- (3) Ensure that the mating faces are absolutely clean and the 25 mm diameter 'O' ring seal is correctly located in its recess. Excess force is not required.
- (4) Fit the gauge to be tested (for installation testing use a known gauge) using the appropriate connection to one gauge stand and the standard test gauge to the other. Joints should be made using the bonded seals provided or if preferred copper or leather washers. The loose connections on the tester base enable gauges to be positioned as required.

CONNECTING PNEUMATIC SUPPLY

- (1) The connection for the pneumatic supply line is situated at the rear of the tester base.
- (2) The inlet manifold is tapped G¹/₄, with a spotface machined in it for sealing purposes, using a bonded seal (item No. 38 in spare seal bag).
Alternatively, an inlet manifold adaptor is supplied which when fitted with the above bonded seal will give an alternative input connection of ¹/₄" N.P.T.
- (3) An isolated regulated pneumatic supply line should be connected to the tester input manifold block.
- (4) Ensure supply valve is shut and release valve is open before turning on the regulated pneumatic supply as quoted on instruction plate situated on the tester.

POST ASSEMBLY TEST

- (1) Fit piston/cylinder unit to base. Blank off gauge connection.
- (2) Apply minimum pressure to piston unit to ensure the unit has not been damaged in transit. The unit should spin freely at its lowest pressure coming to a gradual, not sudden stop. If it does not, or it makes a squealing noise it should be cleaned. (See section 7.7)
- (3) Remove blank plug from gauge stand and carry out a test calibration of a known gauge (see section 4) to ensure that the unit is working correctly over the gauge pressure range.
- (4) Release pressure and remove test gauge

NOTE: To remove the gauge from the equipment, use the appropriate size of spanners on the top section of the gauge connection and on the body of the gauge only. Ensure that the lower part of the gauge connection is not rotated as this may release the gauge stand from the base.

- (5) The equipment is now ready to use.

CAUTION**GENERAL**

The pneumatic dead-weight tester is intended for calibration of clean dry instruments. Dirt and excessive moisture in the base will significantly affect the performance of the unit, and can cause damage, particularly if a piston unit is used for a prolonged period when dirty.

OXYGEN USE

DH-Budenberg do not produce a dead weight tester that is suitable for use on oxygen, non-standard manufacturing procedures can be employed to produce an OIL FREE version, but this should be made clear of its intended use at the earliest.

If the operator is not sure of the condition of the tester with regards as to how it has been used in the past, it is DH-Budenberg recommendation that the base should not be used for calibrating instruments for use on oxygen.

Failure to comply with this procedure would render any liabilities against DH-Budenberg null and void.

If the tester is used to calibrate oxygen instruments it is imperative that no oil/hydrocarbons are present, as this would result in an explosion when it came into contact with oxygen. Calibrate only oil free gauges to avoid contamination of the tester.

Operating Instructions

4.1 PROCEDURE

CPS3500: All positive pressure units - PRESSURE CALIBRATION

- (1) Connect the instrument under test, using suitable adaptor provided. (N.B. for tapered threaded connection PTFE tape should be used for producing an effective seal). It is not recommended that liquid sealants are used as they may contaminate the base.
- (2) Load the piston head/weight carrier with the weight equivalent to the desired pressure. Each weight is marked with the pressure equivalent and piston area.
- (3) Adjust the volume adjuster until it is approximately at its mid-position. Ensuring the gas supply is properly regulated, close the vent valve and slowly open the supply valve to increase the pressure.
- (4) As you slowly reach the desired calibration pressure (an indication is supplied by the system pressure gauge) spin the weights and close the supply valve.

NOTE: THE VALVES HAVE A SNUBBING ACTION TO EASE ADJUSTMENT, AND A SOFT SEAT TO MAKE SEALING RELIABLE AND SIMPLE. THE VALVES ONLY REQUIRE TO BE FINGER TIGHT TO SEAL. OVERTIGHTENING THE VALVES WILL RESULT IN A SHORTENING OF THE LIFE OF THE SEAL AND THUS INVOLVE MAINTENANCE. THE VALVE HANDLE CAN BE POSITIONED TO SUIT THE OPERATORS PREFERRED ANGLE OF OPERATION. TO ALTER PLACE THUMB ON THE ROUND DIAMETER ON THE HANDLE AND LIFT THE HANDLE ARM TOWARDS THE OPERATOR. WHILE IN THE UP POSITION TURN CLOCKWISE/ANTI-CLOCKWISE TO THE DESIRED OPERATING ANGLE. RELEASING THE HANDLE WILL RE-ENGAGE THE HANDLE TO THE SPINDLE.

- (5) By turning clockwise the volume adjuster handle the piston unit will rise and "float" in its operating band. The correct pressure has been achieved when the weights are spinning and it is floating in its operating band. By turning anti-clockwise the volume adjuster handle, the piston unit will fall.

NOTE: During calibration the weights should be rotated by hand. It is desirable that the weights should only be rotated when approximately the correct pressure is obtained. Weights should not be brought to rest by fully releasing the pressure and allowing the piston head to rotate against its stop under the full load of the weight pile.

PROCEDURE

CPS3500: -1 to -0.015 bar VACUUM CALIBRATION

- (1) Fit the Model 24 vacuum adaptor to the left hand gauge stand.
- (2) Slide annular weights over the neck of the adaptor before fixing the piston/cylinder unit to it. Load the required weights onto the underside of the piston head.
- (3) Carry out procedures 3 onwards as described above.

CPS3500: 1 to 70 bar and 1 to 120 bar ONLY

The procedure for generating pressure is as described above.

In this tester the air pressure is applied to the surface of the oil which lubricates the piston unit. Before applying pressure to the tester, fill the unit with oil supplied through the filler hole using an oil can. There is a slight leakage of oil past the piston and occasionally the reservoir will need to be topped up. Mineral oil viscosity grade VG22 is supplied with the tester.

If the tester is to be used to calibrate oxygen gauges the tester should be thoroughly degreased and an inert oil used to lubricate the piston. Chlorofluorocarbon oils may be used. Other suitable oils are Fomblin (Montedison) or Fluorolube (Hooker Chemical Corporation). Do not admit oxygen into the tester. Gas/Air supply should be completely oil free for safety.

If the piston unit is removed from the tester the connection should be blanked, care being taken not to invert the unit and the unit stored safely in an upright position. If the unit is removed for a long period then it should be drained of oil and stored upside down on the weight carrier.

If the tester or piston units are to be carried around then the unit must always be kept in the upright position.

4.2 COMPLETION

- (1) After the test is finished, stop the weights rotating.
- (2) Gently open the vent valve to release the pressure in the system.
- (3) The base is now ready for another test and any residual pressure is relieved.

4.3 CLEANING GAUGES

WARNING:

THIS CLEANING DEGREASING PROCESS IS ONLY SUITABLE FOR USE WITH PRESSURE GAUGES WITH EITHER PHOSPHOR BRONZE, BERYLLIUM COPPER, MONEL OR STAINLESS STEEL BOURDON TUBES IN THE FORM OF A 'C'.

IT IS NOT ADVISABLE TO DEGREASE PRESSURE GAUGES WITH STEEL BOURDON TUBES SINCE A VERY SMALL AMOUNT OF CORROSION ON THE BORE OF A BOURDON TUBE CAN CAUSE INACCURACIES OF READING AND EARLY FAILURE OF THE TUBE.

THIS METHOD OF CLEANING IS NOT SUITABLE FOR USE WITH PRESSURE GAUGES WHICH ARE FITTED WITH COILED BOURDON TUBES, NOR ANY GAUGES WHICH ARE TO BE USED ON OXYGEN, AS COMPLETE REMOVAL OF OIL IS NOT ASSURED, REFER TO MANUFACTURER.

EQUIPMENT

This consists of a syringe and a special needle with the point bent through 90°.

INSTRUCTIONS

- (1) Fill syringe with solvent (Proprietary cold degreasing liquid).
- (2) With gauge connection pointing upwards, put needle into connection and insert by feel the point into the hole leading to the tube.
- (3) Inject the solvent. Ideally the tube should be half full.
- (4) Shake gauge in various attitudes to agitate solvent.
- (5) Suck solvent back into syringe, holding gauge at an angle.
- (6) Check that solvent removed is clean. To be sure that all oil has been removed, repeat cleaning process until solvent removed from gauge is as clean as that put in.
- (7) Shake out solvent remaining in gauge.

Cleaning Of Gauges

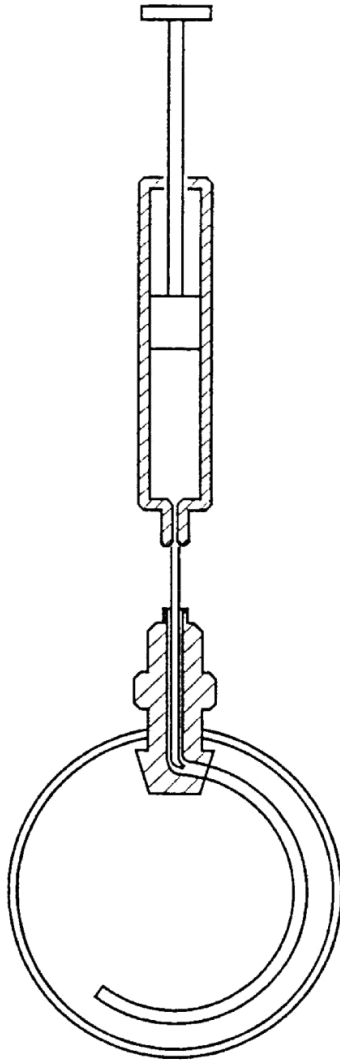

Filling with solvent

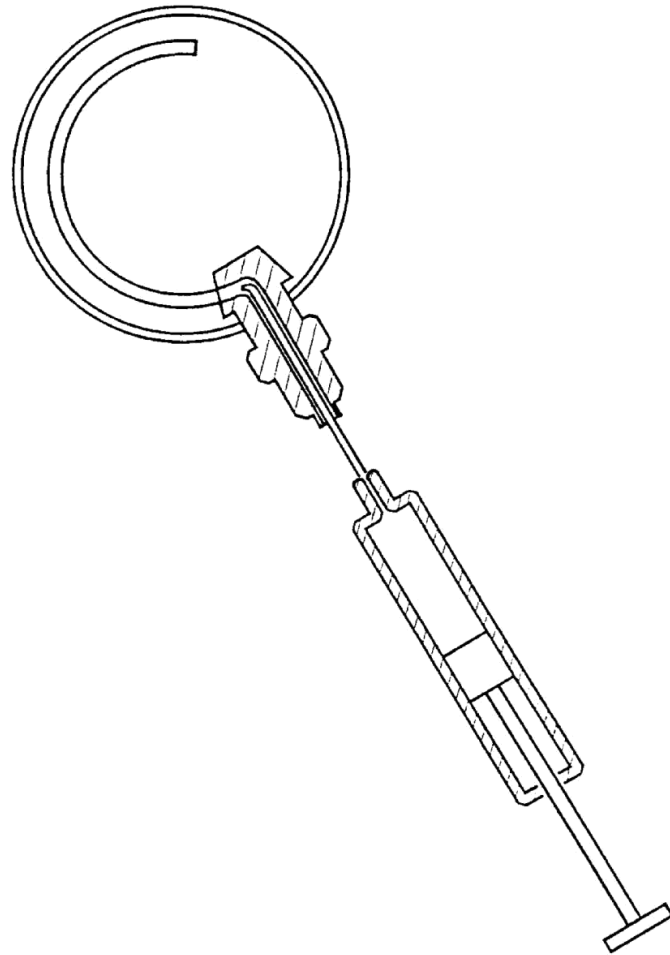

Removing the solvent

4.4 TEMPERATURE MEASUREMENT OF PISTON UNITS

For many purposes such as calibrating most types of dial gauges and transducers, accurate knowledge of the temperature of a piston unit is not necessary. However, in order to achieve the utmost accuracy from a dead-weight tester it is important to know the temperature of the piston unit as close as possible to the working part of the unit.

In laboratories where the room temperature is controlled it is most likely that the temperature of the working parts of the unit will not differ from the ambient temperature by more than 0.5°C. When working in uncontrolled temperatures, however, one would have to measure the temperature of the piston unit.

A possible way to do this is to use a disc shaped thermistor type probe sensing element taped to the outer surface of the piston unit. The sensing element should be insulated from the ambient temperature by covering the element with a thin strip of polystyrene, or other insulating material, then taping this to the piston unit.

We can supply a suitable instrument. Consult your local distributor for advice on availability.

Fault Finding

The following fault finding chart is an aid to fault finding on your equipment in the event of a fault occurring.:-

FAULT	POSSIBLE CAUSE	REMEDY
Equipment does not provide any output pressure.	Pneumatic supply not connected	Check if supply is connected and bottle is pressurised.
	Connection at manifold leaking	Check for leaks with soapy water
	Supply valve blocked	Check sealing arrangement Strip down or return to supplier.
	Gauge connection leaking	Check seals & replace if necessary.
	Supply valve handle disconnected from spindle	Examine supply valve tighten up screw securing valve handle to spindle as necessary.
	If unable to locate cause	Check for leaks/return to DH·Budenberg.
	Incorrect operating procedure is being followed	Ensure correct operating procedure is being followed (see section 4).
Equipment provides pressure but pressure decays to zero	Vent valve soft seat faulty; present by hissing noise	Re-tighten release valve change seal if applicable.
	Missing or damaged seals present by hissing noise	Examine seals on equipment to ensure they are fitted correctly and are undamaged - replace if necessary.
	If unable to locate a cause	Return to DH·Budenberg.
Weights not spinning	Weights are on stops	Ensure weights are not on their stops.
	Piston/Cylinder unit dirty	Clean Piston/Cylinder unit as section 7.7.
	Piston/Cylinder unit jammed	Return to DH·Budenberg.

Periodic Maintenance

Cleaning the base unit is the only periodic maintenance required. With normal use no further maintenance should be necessary. If required the tester or comparator can be returned to our works for re-conditioning. If unable to return the unit, details on stripping the unit and replacing the spare parts are given in the corrective maintenance section. Accuracy, overhaul, and re-certification is also explained in corrective maintenance.

The base unit should be wiped down with a damp cloth to remove any dirt, debris which may enter into the tester. All handles should be checked to ensure they are correctly fastened to their spindles. The gap between the inside edge of the cover and the base should be inspected to ensure released pressure can vent away from the case.

The volume adjuster spindle should be lightly smeared with a silicone grease if it becomes difficult to operate.

Corrective Maintenance

7.1 GENERAL

This section contains details of stripping the unit and replacing the spare parts which are listed in Section 8.

The component identification numbers in brackets in each procedure refer to relevant detail drawing in section 8.

7.2 REMOVING THE COVER

- (1) Disconnect the pneumatic supply. Ensure it is isolated before breaking the pressure joint.
- (2) Unscrew gauge stands and/or piston/cylinder unit.
- (3) Remove handwheels off supply/vent valves and volume adjuster handle.
- (4) Remove 4 - off black plastic cover in the four extreme corners and unscrew the screws.
- (5) Lift cover from back and slide forwards to clear volume adjuster.

7.3 REPLACING SEALS ON SUPPLY/RELEASE VALVES

- (1) Remove valve handles off supply/vent valves.
- (2) Unscrew gland nut, and turn spindle anti-clockwise until spindle, gland packing and bonded seal are removed from the valve body.
- (3) Remove used valve seat with a suitable hooked tool.
- (4) Ensure soft seat face of valve seat is clean and free from any marks, indents etc.
- (5) Insert new soft seat into valve body. With a suitable drift ensure soft seat is seated correctly.
- (6) Re-assemble bonded seal, gland packing and spindle, ensuring all dirt etc has been removed.

7.4 SUPPLY/VENT VALVE TESTING PROCEDURE

- (1) Blank off piston cylinder stand and gauge stand(s).
- (2) Close supply valve and vent valve.
- (3) Apply maximum pressure to dead weight tester/comparator (as indicated on system pressure gauge) and observe the gauge for 5-10 minutes to ensure no pressure is leaking past supply valve soft seat.
- (4) Open supply valve and check supply valve gland nut for any leaks with soapy water or other suitable leak detection method.
- (5) Close supply valve (with maximum pressure in system) and observe system pressure is leaking past vent valve soft seat.

7.5 VOLUME ADJUSTER

The volume adjuster should not be dismantled due to the complexity of the internal seals arrangement unless performed by an experienced technician as special tools are needed for assembly/re-assembly. DH-Budenberg can re-new seals/clean if required without sending the complete dead-weight tester back.

- (1) Fully wind in clockwise volume adjuster handle before removing handwheel.
- (2) Slacken off back nuts (2 - off) of pressure connection at end of volume adjuster and remove pipe ends and back nuts from fittings.
- (3) Using a suitable pin spanner unscrew lock nut and remove volume adjuster body from bracket.

7.6 SYSTEM GAUGE INDICATOR

- (1) Using suitable spanners located on the gauge body and tester loose union remove the gauge from the tester.
- (2) Replace the bonded seal situated at the bottom of the loose union connection.
- (3) Re-fit gauge, position accordingly.

NOTE: Ensure gauge is of the correct pressure range required. Failure to do so could result in damaging the gauge.

7.7 PISTON/CYLINDER UNIT

As the piston/cylinder unit represents a high proportion of the total value of the tester, it should always be handled with care and every effort made to keep it clean.

The piston/cylinder unit is made to extremely fine limits of accuracy and it is not advisable to dismantle it; however it will require periodic cleaning. The following procedure should be followed:

- (1) Remove piston/cylinder unit from the base, and dis-assemble the piston/cylinder unit.
- (2) With a clean dry lint free cloth rub the surface of the piston .
- (3) Tightly pull through the cylinder a clean dry lint free cloth.
- (4) Re-assemble the piston/cylinder unit. Great care should be taken when re-assembling the piston to the cylinder -
DO NOT FORCE UNITS TOGETHER.
- (5) If this does not remedy the fault then either :
 - a) wash the piston/cylinder in a mild soapy solution, rinse and dry thoroughly and clean with a lint free cloth as above.
 - b) Clean the piston/cylinder with acetone, dry thoroughly and clean with a lint free cloth as above.

The above methods are applicable to Model CPS3500: 0.015 to 25 bar piston/cylinder units. A CPS3500: 1 to 120 bar piston/cylinder unit is lubricated with a hydraulic fluid and therefore is not as susceptible to contamination affecting its performance.

Should the unit become damaged it should be returned complete for replacement or repair. Parts from different units are not inter-changeable as they have to be weighed and evaluated as a whole.

The serial number of the piston/cylinder unit appears in the certificate of accuracy and is marked on the body of the unit. This number, as well as the tester serial number should always be quoted in correspondence concerning the piston/cylinder unit.

The piston/cylinder connection should be blanked if it is removed from the tester. If the unit is taken off for any reason it should be stored upside-down resting on the weight carrier (except CPS3500: 1 to 120 bar piston unit refer to section Cleaning Piston/Cylinder Units).

This covers stripping the unit to enable simple repairs and the fitting of recommended spare parts to be carried out.

7.8 FACTORY OVERHAUL AND RE-CERTIFICATION OF DEAD-WEIGHT TESTERS MAINTENANCE OF ACCURACY

The accuracy of a dead-weight tester depends primarily on the effective area of the piston unit and on the weights applied to the piston. The effective area of the piston unit can be affected by wear of the unit. This is generally caused by contamination in the tester by foreign matter from instruments being calibrated, by water, or chemicals from instruments, or by rust or corrosion caused by contaminants.

Weights are made of austenitic stainless steel which are entirely stable. In the past we have supplied testers with specially treated cast iron weights and martensitic stainless steel weights. Whilst these earlier weights were entirely suitable under normal conditions of use, they may exhibit some instability of mass if left in contact with damp materials or water.

NEED FOR OVERHAUL AND RE-CERTIFICATION

We recommend that the tester be returned to us for overhaul and re-certification at any time if when used in accordance with instructions:

- (a) The piston does not spin freely (after cleaning).
- (b) The rate of fall of the piston is appreciably greater than when new and makes use of the tester difficult.
- (c) The weights are damaged or seriously corroded.
- (d) The tester cannot be made to operate satisfactorily due to wear or damage to pump piping or valves which cannot be rectified by the user.

For periodic maintenance and recertification the actual period will depend on how a tester is used. A tester kept in a laboratory and carefully used might need to be returned every 2 to 3 years. A tester carried around from site to site and used for calibrating high accuracy gauges or transducers from industrial process plant or for measuring pressures directly might well need to be returned at intervals of less than one year.

The actual period between overhaul and re-certification should be fixed by the user in the light of the above comments taking into account the requirements of any inspection authority which might be involved.

IDENTIFICATION OF WEIGHTS

All weight sets supplied with a dead-weight tester have allocated, and are marked with, a weight set number. Additionally, if users wish to ensure that only specific weights sets are used with an individual dead-weight tester or piston/cylinder unit, then the serial number of the tester, and/or piston/cylinder unit may also be marked on the main weights. Regrettably due to their size, increment weights can only be marked with the serial number of a piston/cylinder unit.

OVERHAUL AND RE-CERTIFICATION

To provide the best possible service, testers should be returned as complete units comprising the base, the piston and cylinder unit, and all weights. Users may at their discretion elect to service the base themselves and only return the piston and cylinder unit with weights for overhaul. In such instances, certification issued after overhaul can only refer to the piston and cylinder and weight set numbers and not to the base to which they were originally fitted.

Tester bases will be stripped, all pipework cleaned, all seals replaced, worn components replaced where desirable, and all reassembled and tested.

The weights will all be checked and brought to within original limits if possible. If one or two weights are missing or beyond economic repair they will be replaced. If more are missing/beyond economic repair customers instructions will be sought.

The piston unit will be checked for accuracy and sensitivity. If it is not satisfactory for any reason a quotation will be submitted for a replacement unit.

A new certificate of accuracy will be issued for each overhauled tester. Unless otherwise instructed on order when there has been a slight change in area of the piston unit the certificate will reflect this; the accuracy will not be affected by more than 0.03%. For example the certificate of accuracy of an overhauled tester might show that the error does not exceed 0.05% when the original certificate shows that the error did not exceed 0.02%.

We can issue UKAS certificates of calibration for overhauled testers and also for testers in good condition whether or not of our manufacture. Details will be supplied on request.

ORDERING AND PRICING

No tester will be overhauled if it is not economical to do so. By far the most expensive component likely to need replacement is the piston unit. This unit will not be replaced unless customers approval has been obtained.

When customers ordering procedure does not allow an open order to be placed we quote a basic price for the overhaul and re-certification of a particular model of tester. This assumes the tester and weights are in good condition and covers stripping, cleaning of pipework, replacement of seals, re-assembly and testing, checking of weights and of piston unit.

The basic price covers our certificate of accuracy in the typical form. Customers requiring a more detailed certificate of calibration should state this on their order.

Any additional work required will not be carried out but will be quoted separately. These additional charges will be detailed on the invoice but the piston units will not be replaced without customers approval. Orders should therefore state basic quoted price "plus additional service and replacement parts as required".

Spare Parts

8.1 SPARE PARTS LIST

The list covers all the items subject to wear. Any inquiries should be addressed to DH-Budenberg.

UNIT	ITEM No	DESCRIPTION	PART No
Piston/Cylinder (Not for model CPP120-X)	1	Piston/Cylinder assembly CPS3500: 0.015 to 1 bar	3/4020
		CPS3500: 0.1 to 7 bar	3/4205
		CPS3500: 0.2 to 25 bar	3/4110
		CPS3500: 1 to 120 bar	3/4210
	8 *	('O' ring for model 556 P.C.U)	YR1385
Gauge stand	10*	'O' ring for model CPS3500: 1 to 120 bar	YR1340
	2	Model CPB3500 Gauge stand PA/6051	YC3659
	7*	'O' ring (also used on P.C.Us)	YR1390
Supply valve		Supply valve complete with fittings	YC5880
Vent valve		Vent valve complete with fittings	YC5875
Volume adjuster	41*	Supply/Vent valve bonded seal	YR1351
	40*	Supply/Vent valve soft seat	SOR10
	39*	Supply/Vent valve gland packing	YR1435
		Volume adjuster assembly with fittings	QA/3105
	36*	Volume adjuster anti-extrusion rings	YR1479
System pressure gauge	35*	Volume adjuster 'O'rings	YR6490
	37*	Bonded seal	YR1337
		CPS3500: 0.015 to 1 bar	3/4622
		CPS3500: 0.1 to 7 bar	3/4624
		CPS3500: 0.2 to 25 bar	3/4626
	31*	CPS3500: 1 to 120 bar	3/4628
		Bonded seal	YR1352

* ITEMS MARKED THUS * ARE CONTAINED IN THE BAG OF SEALS SUPPLIED WITH THE TESTER WHICH IS ALSO AVAILABLE AS A SPARE

8.2 ORDERING SPARES

When ordering spares or making inquiries always give:

- (1) Tester Model No. (on front of this manual)
- (2) Tester Serial No. (on nameplate)
- (3) Description of part. See spare parts lists.

Whilst every effort is made to ensure that the correct parts are supplied, this cannot be guaranteed unless full information is given.

Ordering spares can be carried out from our service department at the following address:

DH-Budenberg
10 Huntsman Drive, Northbank Industrial Estate,
Irlam, Manchester
M44 5EG United Kingdom

Tel: +44 (0)870 7877370
E-mail: sales@wika.com

Spare seals/assemblies for Model CPB120, CPP120-X

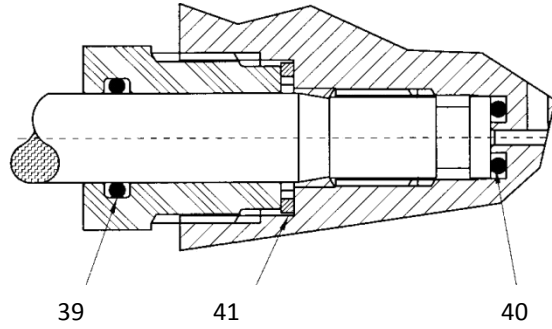

Enlarged Section
Valve
Sealing Arrangement

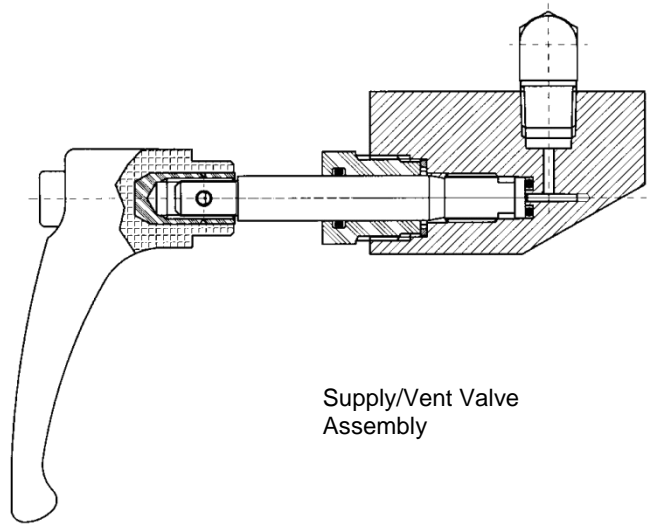

Supply/Vent Valve
Assembly

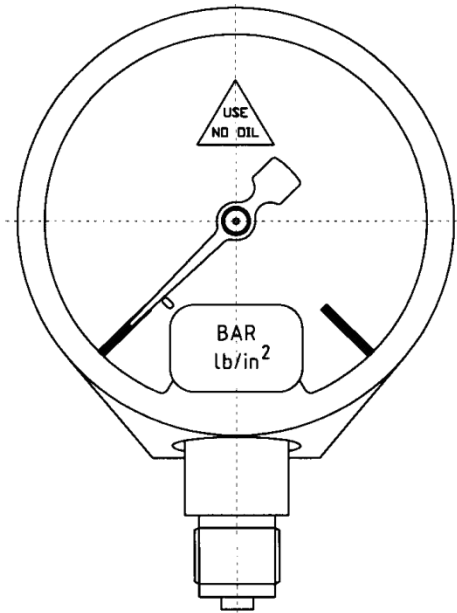

System Pressure
Gauge

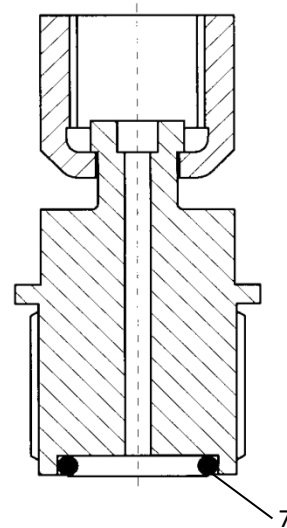

Gauge Stand

Spare seals/assemblies for Model CPB120, CPP120-X

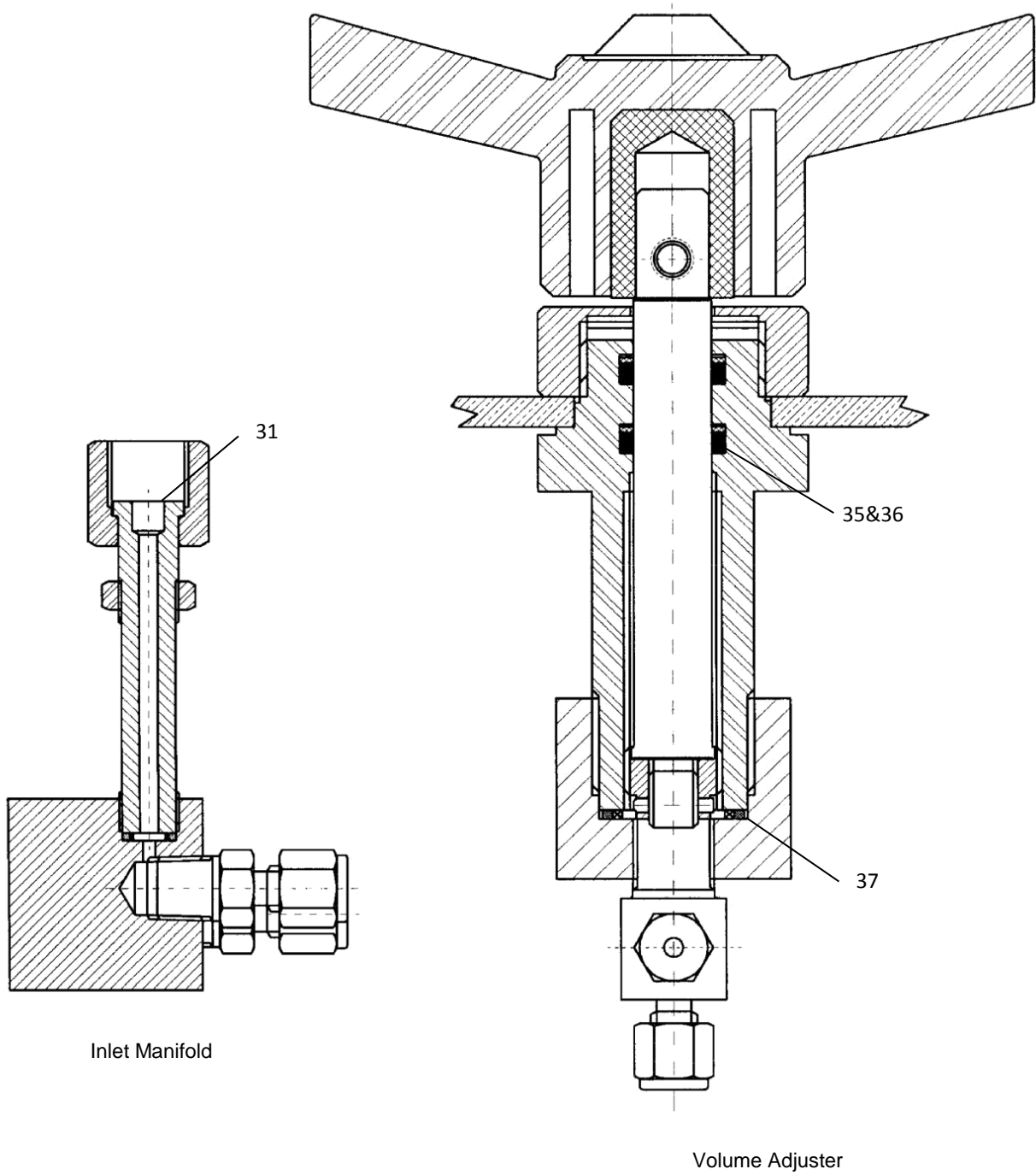

Spare Seal Identification Chart

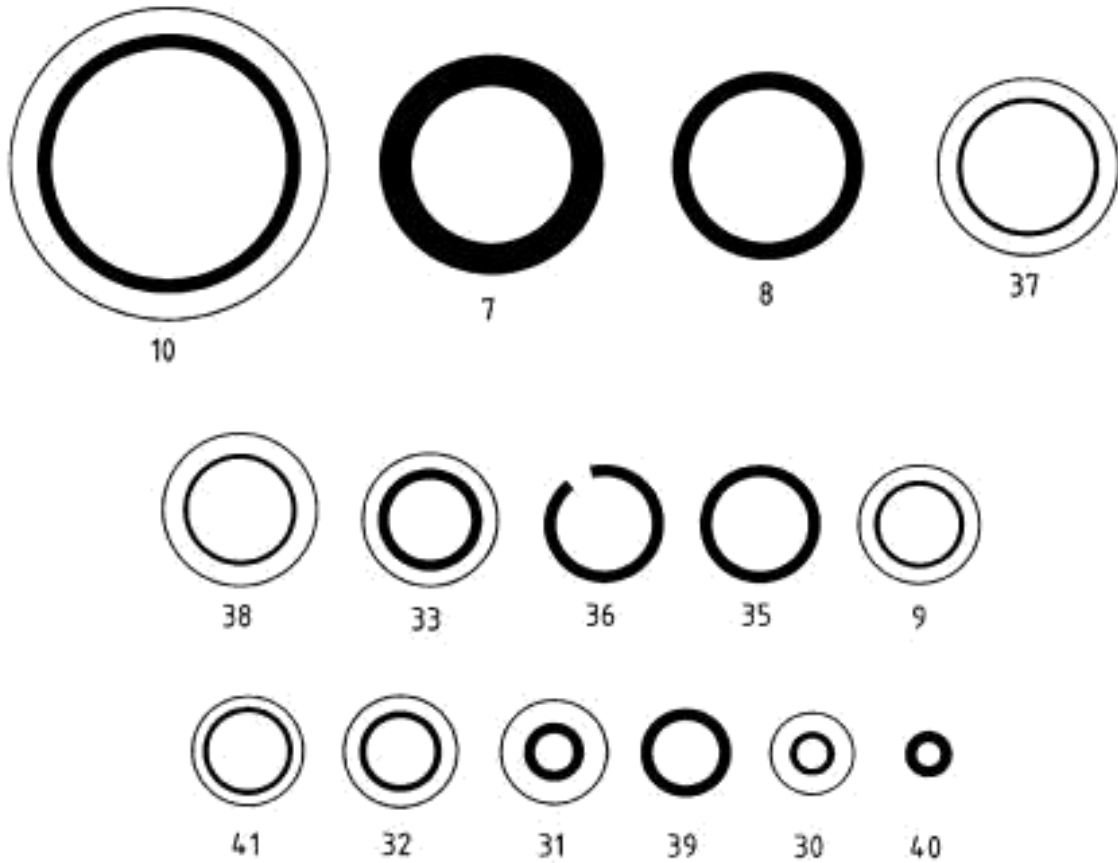

ITEM No	Qty	PART No
7	4	YR1390
8	1	YR1385
9	1	YR1335
10	2	YR1340
30	2	YR1315
31	5	YR1352
32	2	YR1320
33	4	YR1321
35	2	YR6490
36	2	YR1479
37	2	YR1337
38	2	YR1336
39	2	YR1435
40	2	SDR10
41	2	YR1351

Optional Extras

9.1 MODEL 24 VACUUM ADAPTOR

A Model 24 vacuum adaptor enables a CPS3500 Piston unit: 0.015 to 1 bar piston/cylinder unit to be mounted upside down and so with annular weights to operate at a pressure under atmosphere.

9.2 MODEL 27 - TWO GAUGE STAND

This is available for the testing of two gauges simultaneously.

9.3 MODEL 35 AIR/LIQUID INTERFACE

The Model 35 low pressure air/liquid interface is designed to enable laboratories, instrument calibration departments, etc to calibrate instruments up to 25 bar (400 lb/in²) on liquid* using an air dead-weight tester which is more accurate and will operate at much lower pressures than an oil dead-weight tester.

* Liquids which attack nitrile rubber seals cannot be used.

9.4 FINE INCREMENT WEIGHTS

Extra weight sets to give fine increments of pressure less than those normally supplied with the tester can be supplied for use with most piston/cylinder units.

9.5 UKAS CERTIFICATE OF CALIBRATION

All dead-weight testers are available with certificates of calibration on pressure, also certificates of effective area of the piston unit and of the mass of the weights. Consult your local distributor for advice.