

Technical Information

Cleanfit CPA875

Retractable process assembly for sterile and hygienic applications for in-line measurement with standard 12 mm sensors for parameters such as pH, ORP, oxygen and NIR

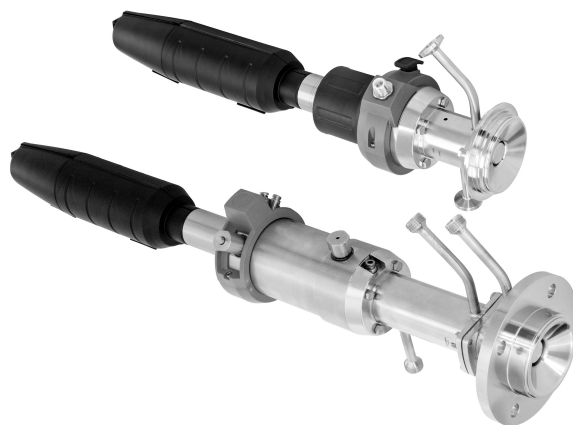

Application

The modular retractable assembly has been consistently developed with safety in mind:

- Safety in operation
- Safety during cleaning for hygienic processes
- Protection against contamination in sterile processes

The assembly is therefore perfectly suitable for use in the following industries:

- Food and beverages
- Biotechnology
- Life sciences
- Special chemicals

Your benefits

- Maximum availability with minimum maintenance
- Safe measurement and accurate measured values
- Higher product quality thanks to reliable measurement results
- Modular design ensures investment is secure
- EHEDG-certified assembly: process connection and service chamber
- Features certified to FDA and USP Class VI

Function and system design

Mode of operation	<p>With the Cleanfit CPA875 retractable assembly, you can carry out pH, ORP, oxygen and other measurements reliably using suitable sensors. You can remove, clean, sterilize or calibrate/adjust the sensors without interrupting the process.</p> <p>The assembly can be installed in both vessels and pipes.</p>
Design	<p>The retractable assembly has a modular design and can therefore be flexibly adapted to a wide array of applications. It is available with both a manual and a pneumatic drive.</p> <p>A choice of two chamber systems is available for the assembly:</p> <ul style="list-style-type: none"> ■ Single-chamber system with a service chamber or ■ double-chamber system with an "inner" service chamber and a "front" service chamber <p>It is possible to choose between the following strokes for the electrode guide:</p> <ul style="list-style-type: none"> ■ 36 mm for flow housing, for example, and ■ 78 mm for installation in vessels, for example <p>This minimizes boundary effects both in the event of flow and in the event of measured values in cooled or heated vessels.</p> <p>All common process connections are available: Clamp / Aseptic DIN 11864 / BioControl / BioConnect / Dairy fitting / ISO228 Thread / Varivent</p>
Safety function	<p>Locking mechanism without sensor If the sensor is not installed, it is not possible to pneumatically or manually move the assembly from the service position to the measuring position.</p> <p>Manual or pneumatic drive The sensor can be driven both manually and pneumatically. The manual drive has a self-retaining thread to hold the sensor in any intermediate position. The manual drive can be used for process pressures up to 8 bar (116 psi). The pneumatic drive can be used for process pressures up to 16 bar (232 psi).</p> <p>Limit position locking if compressed air fails If the compressed air fails in pneumatic assemblies, the assembly remains in the position previously selected. The process pressure cannot force it out of the measuring position and into an intermediate position.</p> <p>Limit position locking with manual drive For position locking, the manual version has an unlocking button in both the measuring position and the service position.</p> <p>Impossible to remove sensor in the measuring position The protection cap for covering the sensor has the following functions:</p> <ul style="list-style-type: none"> – Mechanical sensor safety – Prevents sensor removal in the assembly measuring position <p>The bottom part of the protection cap is partly inserted into the drive and cannot be opened as a result.</p> <p>Non-rotating sensor guide During insertion/retraction, the position of the ridges of the immersion tube in the area of the sensor head retains the pre-setting once selected. This guarantees optimum and clear positioning of the sensor in the process and during cleaning.</p> <p>Limit position detection (can be retrofitted) In the case of assemblies with a pneumatic drive, the service and measuring position of the sensor are detected inductively and reported to connected systems (only for the measuring position in the case of the manual drive assembly).</p>
Cleaning	<p>Medium drains completely out of "inner" service chamber and the "front" service chamber" If the assembly is mounted in an angle of up to 15° to the horizontal, the cleaning medium can drain off completely, without leaving any residue.</p> <p>Special process seal without openings Special, patented aseptic seals are used to avoid any openings that cannot be cleaned. These meet the same hygienic requirements as pipe connections used in corresponding applications (not for NA process connection).</p>

Certified materials

All sealing materials that are in contact with the medium are FDA-certified and meet USP Class VI specifications.

Electropolished materials 1.4435 (AISI 316 L)

All metal parts that are in contact with the medium have a surface roughness of Ra <0.76 µm or optionally Ra <0.38 µm.

The Cleanfit CPA875 assembly has been developed to meet cleanability and sterility demands.

Both versions feature different sealing principles to meet these requirements.

- Double-chamber system with sensor cleaning in the "front" service chamber and single-chamber system for certified cleanability
- Double-chamber system with sensor cleaning in the "inner" service chamber for certified cleanability and sterility

Certified cleanability

EHEDG-certified sterilisability

The assembly, including the service chamber and process connection, can be sterilized according to EHEDG specifications.

EHEDG-certified cleanability of service chamber and process seal

In connection with process seal cleaning in a defined third rest position, the assembly, along with the service chamber and process adapter, have been designed according to the EHEDG guidelines for cleanability and sterilizability and certified by the EHEDG. This certifies that residual medium is not only destroyed but is also removed completely from the service chamber and the sealing surface without leaving any residue. Therefore the service chamber and sealing surface are free from product residue and microorganisms.

Certified sterility

Safety in sterile processes with the CPA875 double-chamber system

Contamination-free assembly insertion/retraction thanks to dynamic sealing based on the "syringe principle"

The moving seals in the "inner" service chamber of the double-chamber assembly prevent already sterilized parts from being contaminated by still non-sterilized parts of the sensor guide. This rules out the possibility of contamination of the service chamber, and ultimately the process, even with strict sterility requirements.

Double-chamber system for safe separation between the process and service chamber

On-the-fly cleaning, recalibration and testing of the sensor in a process with sensitive medium requires the reliable and safe separation of the service chamber from the process. For this purpose the "front" chamber of the double chamber assembly can be exposed to sealing medium, for instance. At the same time, this chamber isolates the temperature from the process. The sensor can therefore be removed, calibrated/adjusted or simply cleaned and tested without affecting the process.

Elements

The assembly is available with a manual or pneumatic drive.

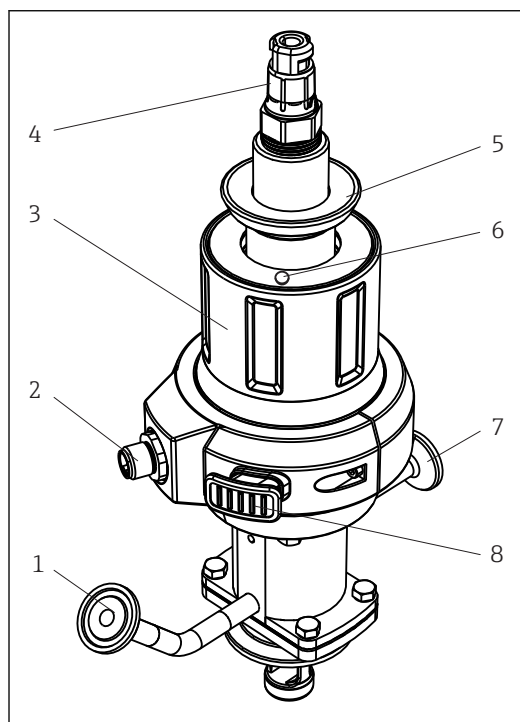

A0020086

1 Assembly with manual drive (without protection cap)

- 1 Rinse connection
- 2 Connection for limit position switch
- 3 Manual drive
- 4 Sensor head
- 5 Fastening ring for protective cap
- 6 Unlocking button (service position)
- 7 Rinse connection
- 8 Unlocking button (measuring position)

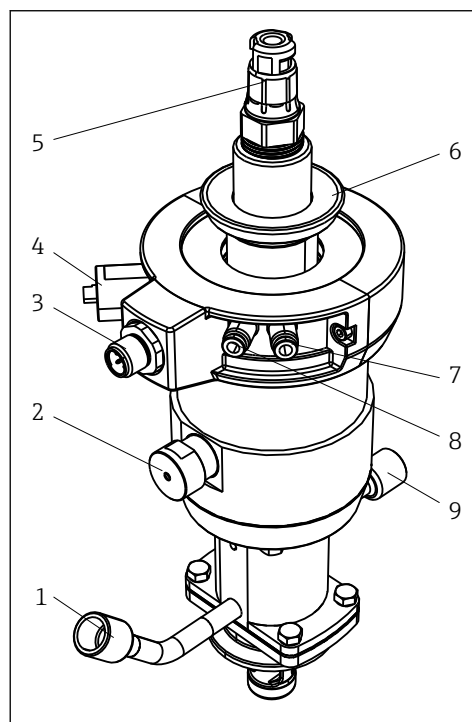

A0029435

2 Assembly with pneumatic drive (without protective cap)

- 1 Rinse connection
- 2 Automatic limit position lock, process
- 3 Connection for limit position switch
- 4 Automatic limit position lock, service
- 5 Sensor head
- 6 Fastening ring for protective cap
- 7 Pneumatic connection (move to measuring position)
- 8 Pneumatic connection (move to service position)
- 9 Rinse connection

Sealing principle

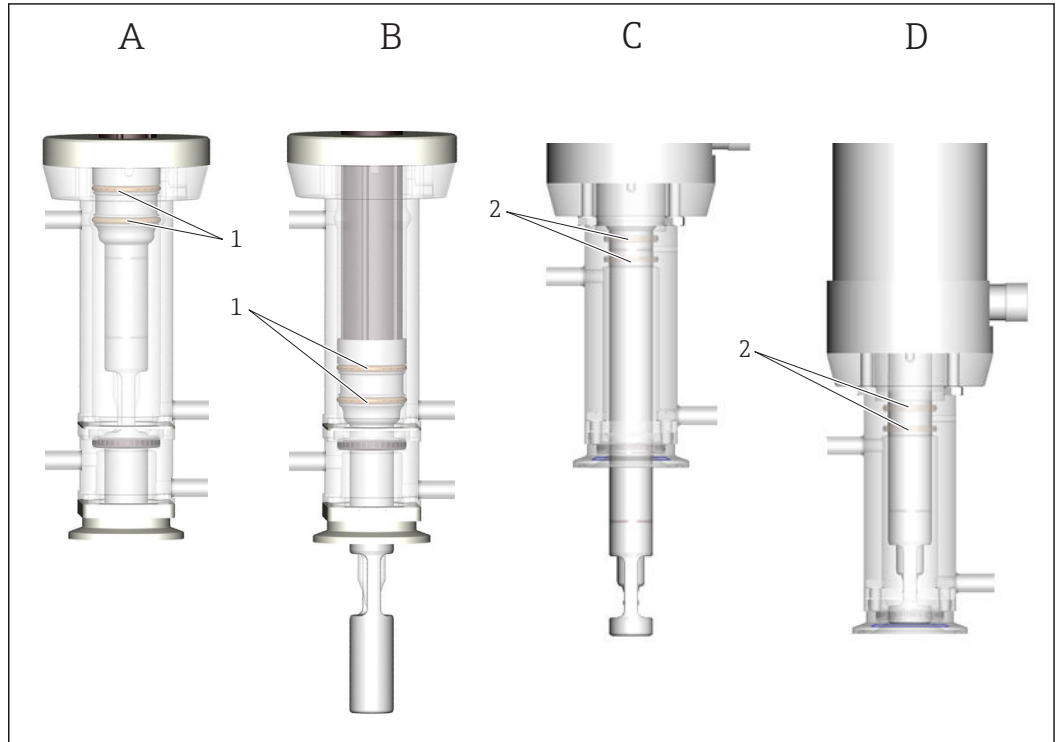

A0021906

3 Sealing principle

- A Double chamber in service position
- B Double chamber in measuring position
- C Single chamber in measuring position
- D Single chamber in service position
- 1 "Moving" seals in the double chamber
- 2 "Fixed" seals in the single chamber

Measuring system with single chamber

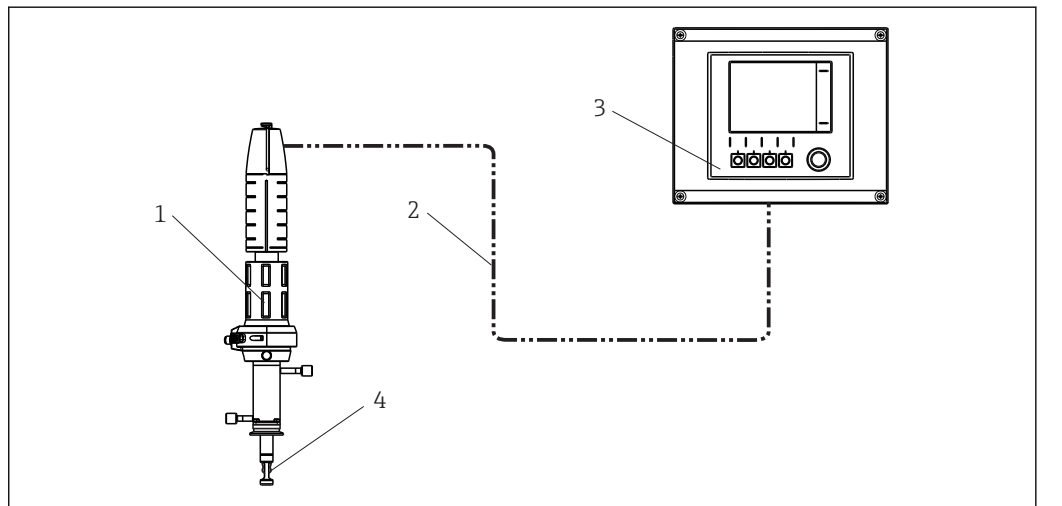

A0017811

4 Measuring system (example)

- 1 Cleanfit assembly CPA875
- 2 Measuring cable
- 3 Liquiline CM44x transmitter
- 4 Sensor

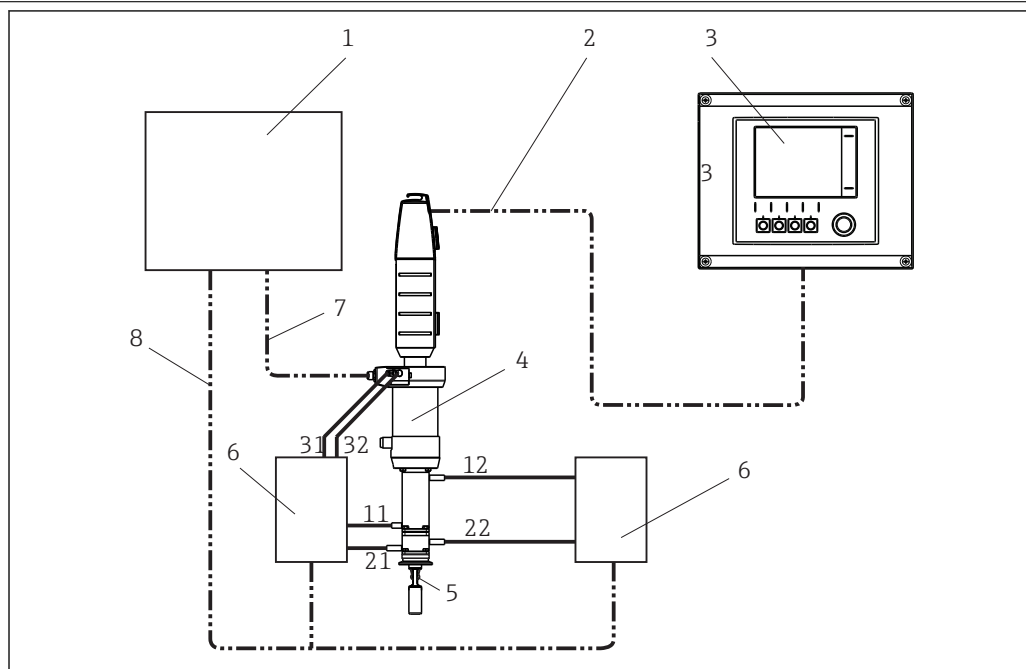
**Measuring system with
double chamber**

A0022821

- 5 *Measuring system with pneumatic drive and double chamber (example)*
- | | | | |
|---|-----------------------------|-------|---|
| 1 | Control unit | 7 | Limit position switch relay signal |
| 2 | Measuring cable | 8 | Control signals (electric/pneumatic) |
| 3 | Liquiline CM44x transmitter | 11/12 | Inlet/outlet of "inner" service chamber |
| 4 | Cleanfit assembly CPA875 | 21/22 | Inlet/outlet of "front" service chamber |
| 5 | Sensor | 31/32 | Drive control |
| 6 | Valve block | | |

Assignment of rinse connections for pressure compensation

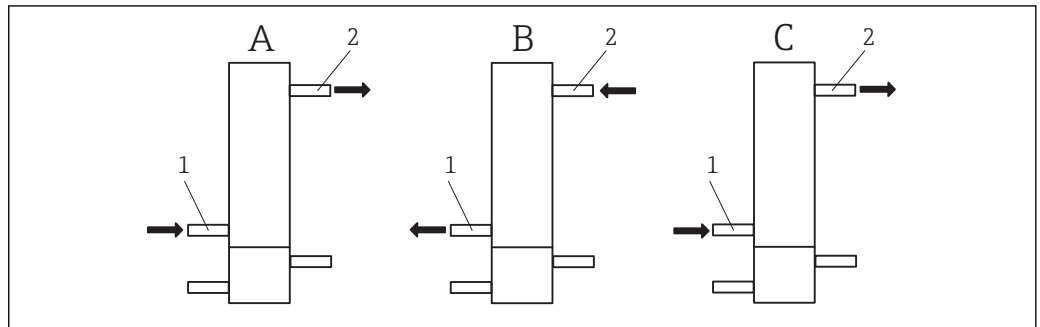

A0022805

6 Assignment of rinse inlet and outlet

- A "Cleaning" state
 B "Move from service position to measuring position" state
 C "Move from measuring position to service position" state
 1 Inlet of "inner" service chamber
 2 Outlet of "inner" service chamber

In the "Cleaning" state (A), the inlet and outlet of the "inner" service chamber are assigned as follows:

- Depending on the cleaning method, cleaning agent and purge gas are supplied via the inlet (1).
- These media are removed via the outlet (2).

In the "Move from service position to measuring position" state (B), the pressure conditions in the "inner" service chamber must be balanced when moving. The inlet and outlet of the "inner" service chamber are assigned as follows:

- The air is removed via the inlet (1) (inlet is open).
- The air is supplied via the outlet (2).

In the "Move from measuring position to service position" state (C), the pressure conditions in the "inner" service chamber must be balanced when moving. The inlet and outlet of the "inner" service chamber are assigned as follows:

- The air is supplied via the inlet (1).
- The air is removed via the outlet (2) (outlet is open).

i The drive must be controlled simultaneously with the control of the inlets and outlets of the "inner" service chamber.

The controller for the inlets, outlets and the drive is installed at the place of installation. It is not included in the scope of delivery of the assembly.

The "front" service chamber can be cleaned as standard. Pressure compensation is not necessary here.

Installation

Orientation

The assembly is designed for installation on tanks and pipes. Suitable process connections must be available for this.

NOTICE

Frost damage to the assembly

- ▶ If used outdoors, ensure that water cannot penetrate the drive.

 For 3-A-compliant installation, please observe the following:

After the device has been mounted, hygienic integrity must be guaranteed. To do so, the leakage hole must be located at the lowest point on the device. In addition, 3-A-compliant process connections must be used.

The assembly is designed in such a way that there are no restrictions with regard to the orientation.

 The sensor that is used can restrict the orientation.

The "inner" service chamber and "front" service chamber can drain on their own with an installation position of between 0° and 15° to the horizontal.

Pneumatic connections for automatic operation

Prerequisites:

- Air pressure 4 to 7 bar (58 to 102 psi)
- Compressed air quality in accordance with ISO 8573-1:2001 Quality class 3.3.3 or 3.4.3
- Solids class 3 (max. 5 µm, max. 5 mg/m³, contamination with particles)
- Water content for temperatures ≥ 15 °C: class 4 pressure condensation point 3 °C or lower
- Water content for temperatures of 5 to 15 °C: class 3 pressure condensation point -20 °C or lower
- Oil content class 3 (max. 1 mg/m³)
- Air temperature: 5 °C or higher
- No continuous air consumption
- Minimum nominal diameter of air pipes: 2 mm (0.08 ")

Connection: Push-in fitting M5, hose 4/2 mm OD/ID (adapter for 6/4 mm OD/ID enclosed)

Damage to seals due to excessive air pressure!

If the air pressure can increase to more than 7 bar (102 psi) (even short pressure surges), a pressure-reducing valve must be installed upstream.

Rinse connection

The service chamber connections of the sterile CPA875 retractable assembly make it possible to clean the chamber and the sensor with water or a cleaning solution at a pressure of 6 bar (87 psi) max. or to sterilize it with steam (SIP).

The retractable assembly can be selected with a single- or double-chamber system. If the double-chamber system is used, all four connections must be connected to inlet and outlet pipes.

 Seals can be damaged if the water pressure is too high.

Install an pressure-reducing valve upstream if there is a possibility that the water pressure will increase to more than 6 bar (87 psi) (including any short pressure surges).

Environment

Ambient temperature range -10 to +70 °C (+10 to +160 °F)

Storage temperature -10 to +70 °C (+10 to +160 °F)

Process

Process temperature -10 to 140 °C (14 to 284 °F)

Process pressure Pneumatic drive 16 bar (232 psi) up to 140 °C (284 °F)
 Manual drive 8 bar (116 psi) up to 140 °C (284 °F)

i The service life of the seals is reduced if process temperatures are constantly high or if SIP is used. The other process conditions may also reduce the service life of the seals.

Temperature/pressure ratings

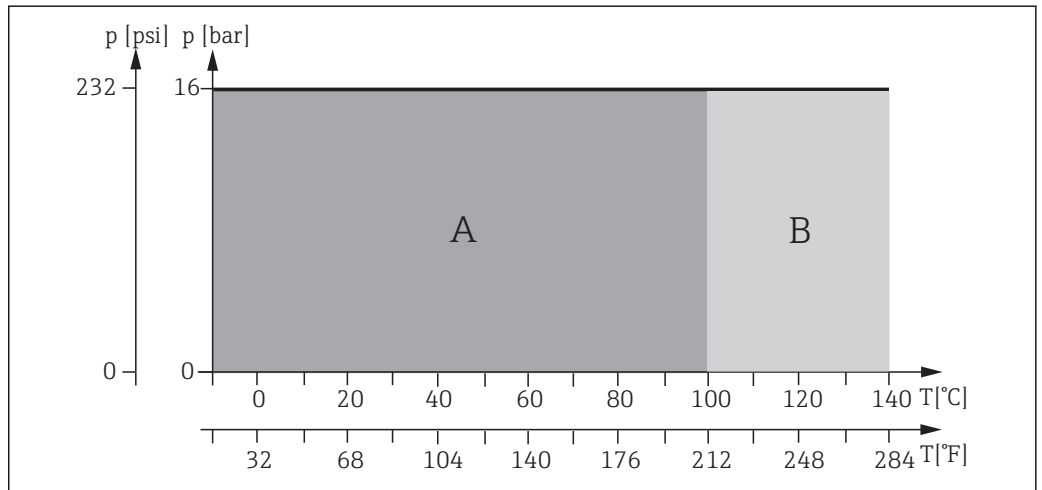

A0029360-EN

7 Pressure-temperature ratings for pneumatic drive

- A Dynamic range
- B Static range

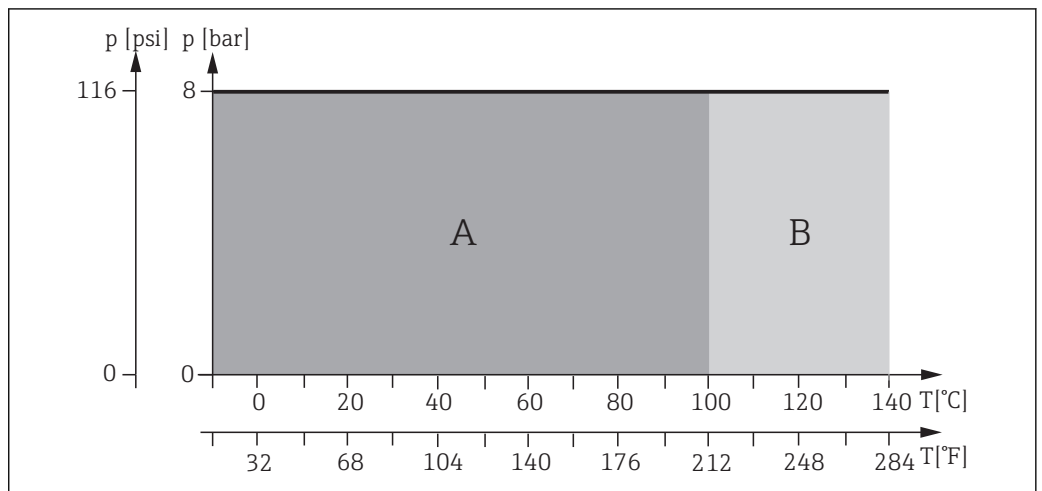

A0029361-EN

8 Pressure-temperature ratings for manual drive

- A Dynamic range
- B Static range

Mechanical construction

Short version

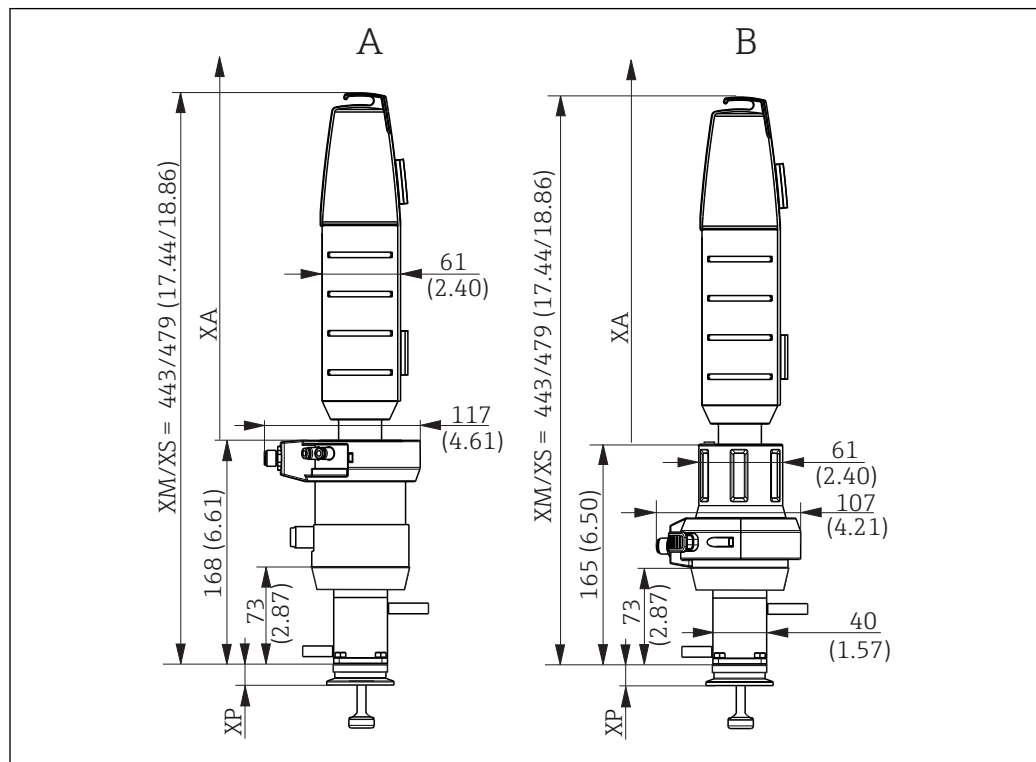

A0018665

9 Dimensions for short version (36 mm stroke)

A Pneumatic drive

B Manual drive

XM Assembly in measuring position

XS Assembly in service position

XP Height of particular process connection (see table below)

XA Necessary mounting distance for sensor replacement = 425 mm (16.73")

Long version

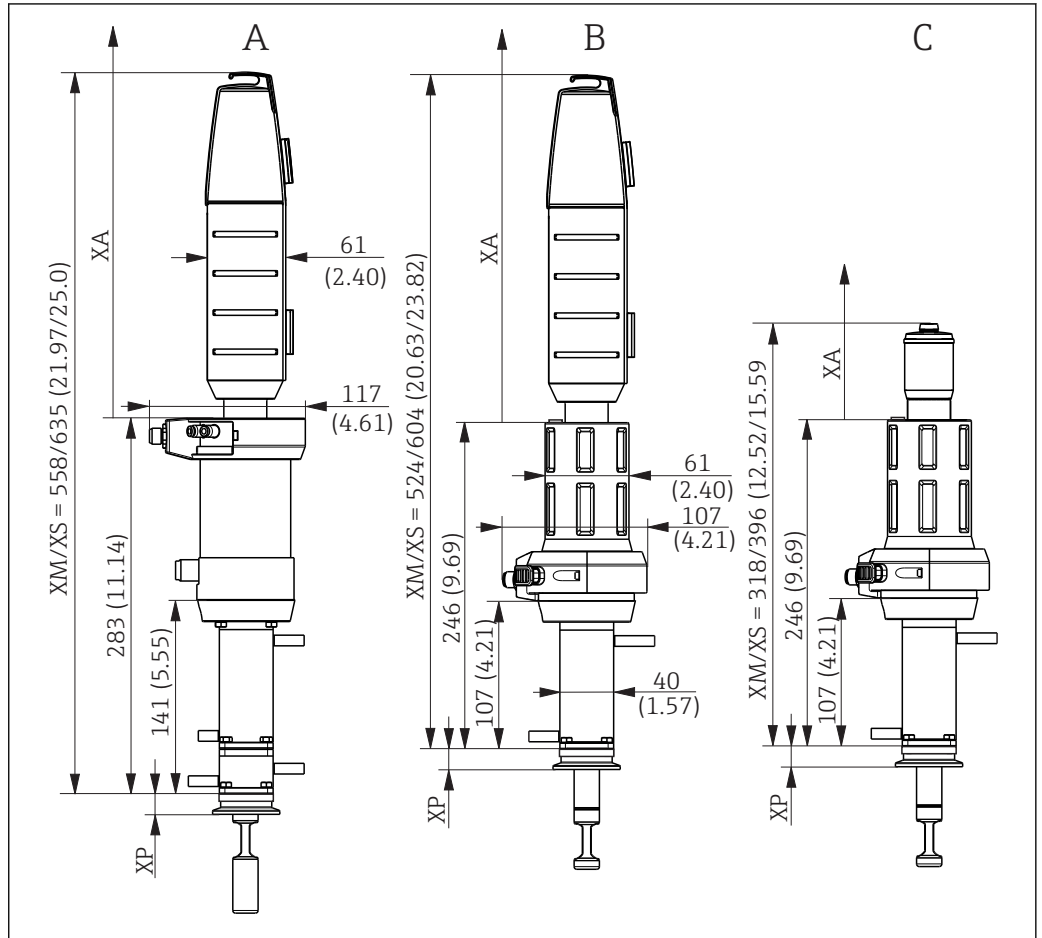





A0018666



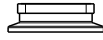

10 Dimensions for long version (78 mm stroke)

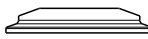
- A Pneumatic drive
- B Manual drive
- C Manual drive with small protection cap
- XM Assembly in measuring position
- XS Assembly in service position
- XP Height of particular process connection (see table below)
- XA Necessary mounting distance for sensor replacement

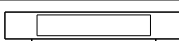
The mounting distance XA is 440 mm (17.32") for 225 mm sensors
 The mounting distance XA is 610 mm (24.02") for 360 mm sensors

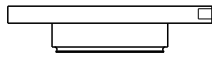
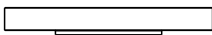
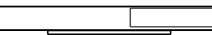
Process connections

Process connection		Height XP in mm (inch)
CA Clamp ISO 2852, ASME BPE-2012, 1½"	 A0021866	14.9 (0.59)
CB Clamp ISO 2852, ASME BPE-2012, 2"	 A0021867	19.5 (0.77)
CC Clamp ISO 2852, ASME BPE-2012, 2½"	 A0021869	13.0 (0.51)
DA Aseptic DN 25 clampable DIN 11864-3 A	 A0021871	16.0 (0.63)
DC Aseptic DN 50 screw-in DIN 11864-1 A	 A0021872	16.0 (0.63)
DF Aseptic DN 50 grooved flange DIN 11864-2 A	 A0021874	14.2 (0.56)

Process connection		Height XP in mm (inch)
EA Neumo BioControl D 65	 A0021875	25.0 (0.98)
EB Neumo BioConnect D 50	 A0021877	10.5 (0.41)
EF Neumo BioConnect D 65	 A0021876	10.5 (0.41)
MA Dairy fitting DN 50 DIN 11851 (EHEDG approval only with seal from Siersema)	 A0021879	14.5 (0.57)
MB Dairy fitting DN 65 DIN 11851 (EHEDG approval only with seal from Siersema)	 A0021878	13.8 (0.54)
VA Varivent flange N (DN 40 to 100)	 A0021873	19.0 (0.75)

Immersion depths

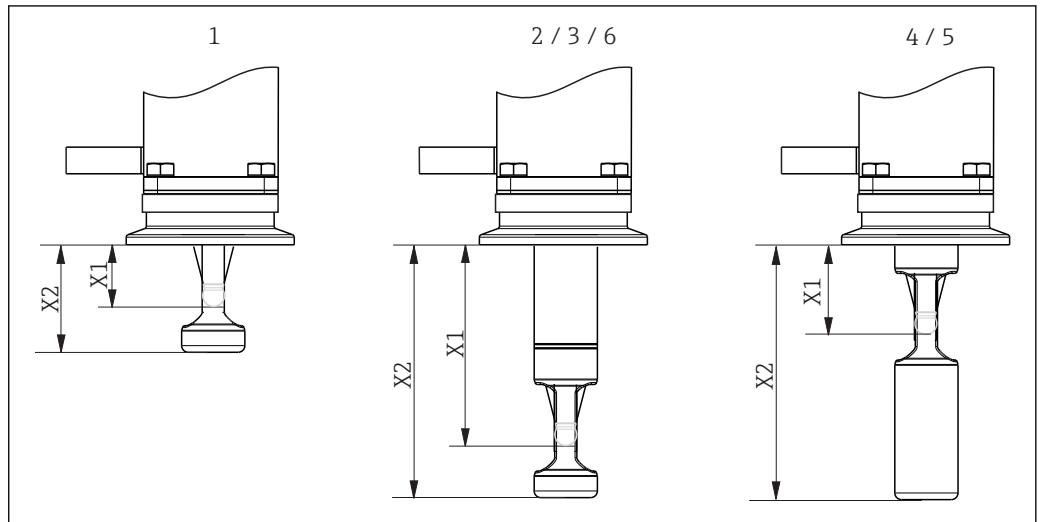

A0017745

11 Immersion depths for different service chambers

- 1 Single chamber / 36 mm stroke / sensor 225 mm incl. KCl
- 2 Single chamber / 78 mm stroke / sensor 225 mm excl. KCl
- 3 Single chamber / 78 mm stroke / sensor 360 mm incl. KCl
- 4 Double chamber / 78 mm stroke / sensor 225 mm excl. KCl / service position, "inner" service chamber
- 5 Double chamber / 78 mm stroke / sensor 360 mm incl. KCl / service position, "inner" service chamber
- 6 Double chamber / 78 mm stroke / sensor 360 mm incl. KCl / service position, "front" service chamber

Immersion depths in mm (inch)

		Service chamber					
Process connection		1	2	3	4	5	6
CA Clamp ISO2852 ASME BPE-2012 1½"	X1	20.6 (0.81)	62.1 (2.44)	62.1 (2.44)	28.1 (1.11)	28.1 (1.11)	62.1 (2.44)
	X2	31.6 (1.24)	73.1 (2.88)	73.1 (2.88)	73.1 (2.88)	73.1 (2.88)	73.1 (2.88)
CB Clamp ISO2852 ASME BPE-2012 2"	X1	16.1 (0.63)	57.6 (2.27)	57.6 (2.27)	23.6 (0.93)	23.6 (0.93)	57.6 (2.27)
	X2	27.1 (1.07)	68.6 (2.70)	68.6 (2.70)	68.6 (2.70)	68.6 (2.70)	68.6 (2.70)
CC Clamp ISO2852 ASME BPE-2012 2½"	X1	22.6 (0.89)	64.1 (2.52)	64.1 (2.52)	30.1 (1.19)	30.1 (1.19)	64.1 (2.52)
	X2	33.6 (1.32)	75.1 (2.96)	75.1 (2.96)	75.1 (2.96)	75.1 (2.96)	75.1 (2.96)
DA Aseptic DN 25 clampable DIN11864-3 A	X1	19.6 (0.77)	61.1 (2.41)	61.1 (2.41)	27.1 (1.07)	27.1 (1.07)	61.1 (2.41)
	X2	30.6 (1.20)	72.1 (2.84)	72.1 (2.84)	72.1 (2.84)	72.1 (2.84)	72.1 (2.84)
DC Aseptic DN 50 screw-in DIN11864-1 A	X1	27.1 (1.07)	68.6 (2.70)	68.6 (2.70)	34.6 (1.36)	34.6 (1.36)	68.6 (2.70)
	X2	38.1 (1.50)	79.6 (3.13)	79.6 (3.13)	79.6 (3.13)	79.6 (3.13)	79.6 (3.13)
DF Aseptic DN 50 Grooved flange DIN11864-2 A	X1	21.4 (0.84)	62.9 (2.48)	62.9 (2.48)	28.9 (1.14)	28.9 (1.14)	62.9 (2.48)
	X2	32.4 (1.28)	73.9 (2.91)	73.9 (2.91)	73.9 (2.91)	73.9 (2.91)	73.9 (2.91)
EA Neumo Biocontrol D65	X1	27.6 (1.09)	69.1 (2.72)	69.1 (2.72)	35.1 (1.38)	35.1 (1.38)	69.1 (2.72)
	X2	38.6 (1.52)	80.1 (3.15)	80.1 (3.15)	80.1 (3.15)	80.1 (3.15)	80.1 (3.15)
EB Neumo Bioconnect D50	X1	22.6 (0.89)	64.1 (2.52)	64.1 (2.52)	30.1 (1.19)	30.1 (1.19)	64.1 (2.52)
	X2	33.6 (1.32)	75.1 (2.96)	75.1 (2.96)	75.1 (2.96)	75.1 (2.96)	75.1 (2.96)
EF Neumo Bioconnect D65	X1	20.6 (0.81)	62.1 (2.44)	62.1 (2.44)	28.1 (1.11)	28.1 (1.11)	62.1 (2.44)
	X2	31.6 (1.24)	73.1 (2.88)	73.1 (2.88)	73.1 (2.88)	73.1 (2.88)	73.1 (2.88)
MA Dairy fitting DN 50 DIN11851	X1	21.1 (0.83)	62.6 (2.46)	62.6 (2.46)	28.6 (1.13)	28.6 (1.13)	62.6 (2.46)
	X2	32.1 (1.26)	73.6 (2.90)	73.6 (2.90)	73.6 (2.90)	73.6 (2.90)	73.6 (2.90)
MB Dairy fitting DN 65 DIN11851	X1	21.8 (0.86)	63.3 (2.49)	63.3 (2.49)	29.3 (1.16)	29.3 (1.16)	63.3 (2.49)
	X2	32.8 (1.29)	74.3 (2.93)	74.3 (2.93)	74.3 (2.93)	74.3 (2.93)	74.3 (2.93)
NA Thread ISO228 G1¼	X1		70.4 (2.77)	70.4 (2.77)			
	X2		81.4 (3.20)	81.4 (3.20)			
VA Varivent flange N (DN 40 to DN 100)	X1	16.6 (0.65)	58.1 (2.29)	58.1 (2.29)	24.1 (0.95)	24.1 (0.95)	58.1 (2.29)
	X2	27.6 (1.09)	69.1 (2.72)	69.1 (2.72)	69.1 (2.72)	69.1 (2.72)	69.1 (2.72)

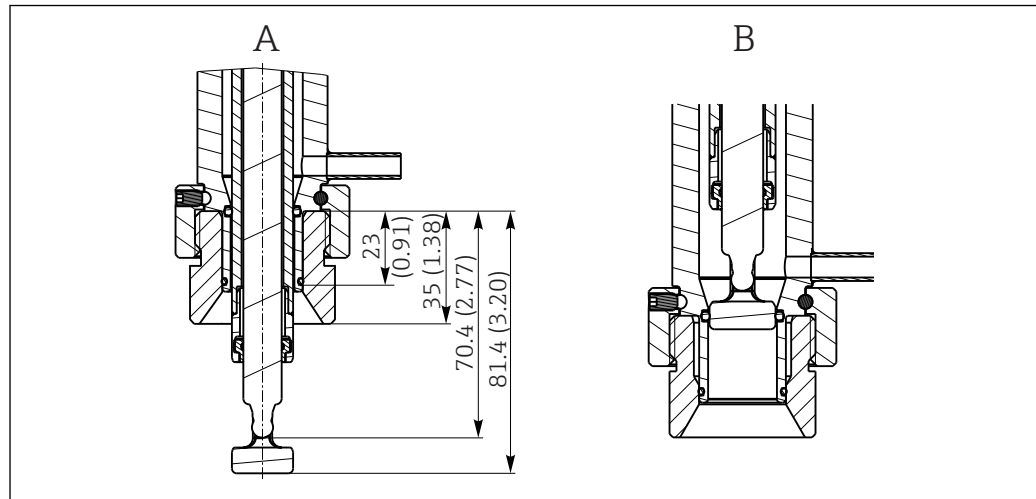

12 Immersion depth in mm (inch) for process connection NA thread ISO228 G1¼ (service chamber 2 and 3) in measurement and service position

Weight

Depends on version:

Pneumatic drive: 3.8 to 6 kg (8.4 to 13.2 lbs) depending on version

Manual drive: 3 to 4.5 kg (6.6 to 9.9 lbs) depending on version

Materials

In contact with medium	
Seals:	EPDM-FDA (USP Class VI) / FKM-FDA (USP Class VI) / FFKM-FDA (USP Class VI)
Immersion tube:	Stainless steel 1.4435 (AISI 316L) Ra < 0.76 / Ra < 0.38
Process connection, service chamber	Stainless steel 1.4435 (AISI 316L) Ra < 0.76
Rinse connections:	Stainless steel 1.4435 (AISI 316L)

Not in contact with medium	
Manual drive:	Stainless steel 1.4301 (AISI 304) or 1.4404 (AISI 316L), plastics PPS CF15, PBT, PP
Pneumatic drive:	Stainless steel 1.4301 (AISI 304) or 1.4404 (AISI 316L), plastics PBT, PP

Sensors	Short version	Gel sensors, ISFET	225 mm
		KCl sensors	225 mm
	Long version	Gel sensors, ISFET	225 mm
		Gel sensors, ISFET	360 mm
		KCl sensors	360 mm

Rinse connections "Inner" service chamber and "front" service chamber are available with the following rinse connections:

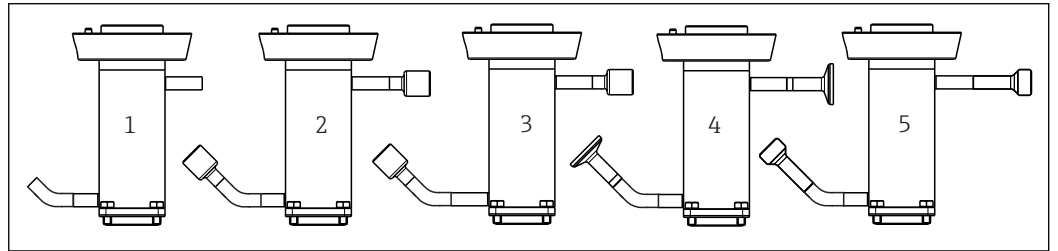

13 Rinse connections

- 1 Pipe 6/8 mm ID/OD
- 2 G1/4 internal
- 3 NPT-F 1/4 internal
- 4 Clamp DN 6 / DN 25 ISO2852
- 5 Bioconnect DN 6

A0021448

Limit position switches

With limit position detection, you can notify a system located downstream (transmitter, switching amplifier, output interface terminal) whether the assembly is in the measurement or service position (in the case of a manual drive, only the measurement position is queried).

The assembly can be ordered directly with limit position detection, or it can be retrofitted at a later stage.

Switching element function:	NAMUR NC contact (inductive)
Switching distance:	1.5 mm (0.06 ")
Nominal voltage:	8 V
Switching frequency:	0 to 5000 Hz
Housing material:	Stainless steel

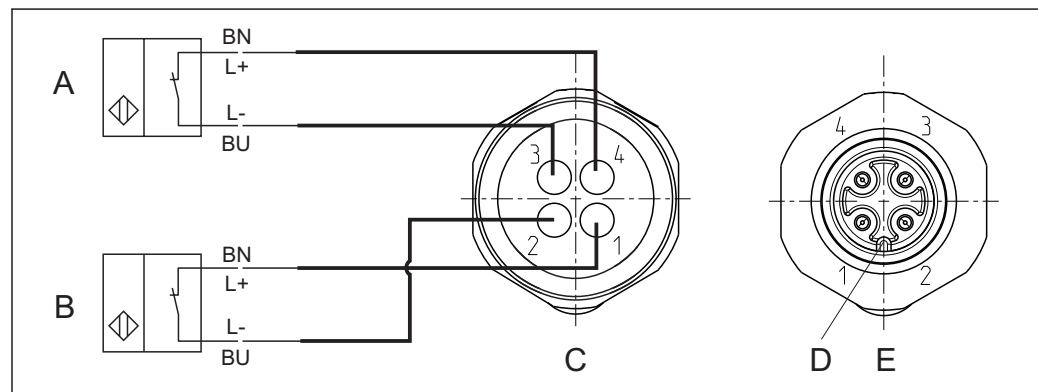

A0017831

14 Inductive limit position switches

- A Limit position switch, service position
- B Limit position switch, measuring position
- C Connector, M12, solder side (inside of assembly)
- D Coding
- E Connector, Pin side (outside of assembly)

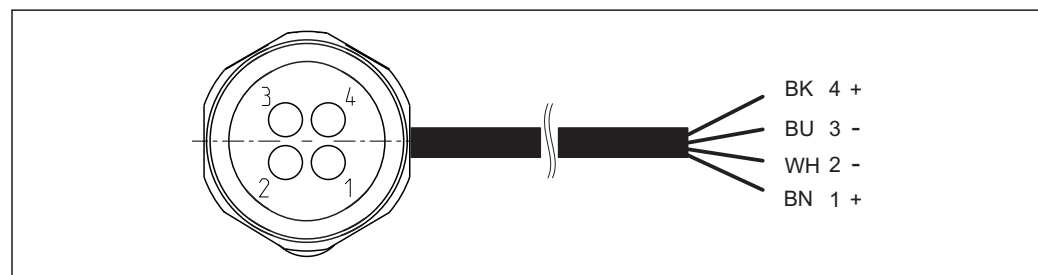

A0022163

15 Connecting cable for limit position switch on transmitter, switching amplifier, output interface terminal etc.

- 1 "Measuring" position
- 2 "Measuring" position
- 3 "Service" position
- 4 "Service" position

i Only pins 1 and 2 are assigned for manually activated assemblies with one switch (measuring position).

Signal table for limit position switches

Position of assembly	Limit position switch for "measuring" position	Limit position switch for "service" position
Measurement	Active LOW (≥ 3 mA)	Active LOW (≥ 3 mA)
Service	Active HIGH (≤ 1 mA)	Active HIGH (≤ 1 mA)

Certificates and approvals

Pharma CoC

No materials or ingredients derived from animals are used during the entire production of all the parts in contact with the process.

Biological reactivity (USP Class VI) (optional)

The plastic and elastomer product components that are in contact with the medium have passed the biological reactivity tests as per USP <87> and <88> Class VI.

EHEDG

The assembly was certified in accordance with the requirements of EHEDG TYP EL Class I (cleanability). The double-chamber version with sensor cleaning in the "inner" service chamber is certified in accordance with EHEDG type EL aseptic class I (cleanability and sterility).

ASME BPE

The Cleanfit CPA875 retractable assembly has been developed following ASME BPE Standard 2012 and meets the relevant requirements of sections GR, SD, DT, MJ, SF, SG, PM, MM and PI which are significant for a retractable assembly.

FDA

All materials in contact with the product are listed by the FDA.



Suitable process connections and seals must be used for hygienic designs as per EHEDG, ASME BPE or 3-A.

RL 94/9/EC (ATEX)

The assembly does not fall within the scope of the directive. However, if conditions for safe use are adhered to, it may be deployed in the hazardous area.

CE/PED

The CPA875 assembly has been manufactured according to good engineering practice in accordance with Article 3, Paragraph 3 of the Pressure Equipment Directive 97/23/EC and therefore is not required to bear the CE label.

EC VO 1935/2004

The assembly meets the requirements for materials that come into contact with food.

Ordering information

Ordering instructions

Create the order code for the assembly as follows:

1. Is the assembly used in the hazardous or non-hazardous area?
2. Select the drive type and the limit position switches.
3. Select the type of service chamber.
4. What material should the wetted seals be made of?
5. What material should the wetted surfaces be made of?
6. Select the suitable process connection.
7. Which connections should the service chamber have?
8. Select the cleaning position.

Order the accessories as follows:

- If you wish to order the accessories together with the assembly, then use the accessory code of the product structure.
- If you only wish to order accessories, then use the order numbers from the "Accessories" section.

Product page

www.endress.com/cpa875

Product Configurator

The navigation area is located on the right of the product page.

1. Under "Device support" click "Configure your selected product".
 - ↳ The Configurator opens in a separate window.
2. Select all the options to configure the device in line with your requirements.
 - ↳ In this way, you receive a valid and complete order code for the device.
3. Export the order code as a PDF or Excel file. To do so, click the appropriate button at the top of the screen.

Scope of delivery

The scope of delivery comprises:

- Assembly in the version ordered
- Operating Instructions

Accessories

i The following are the most important accessories available at the time this documentation was issued. For accessories not listed here, please contact your service or sales office.

The following accessories can be ordered via the product structure (see ordering information):

- Weld-in adapter G1¼, straight, 35 mm, 1.4435 (AISI 316 L), safety nozzle
- Weld-in adapter G1¼, angled, 35 mm, 1.4435 (AISI 316 L), safety nozzle

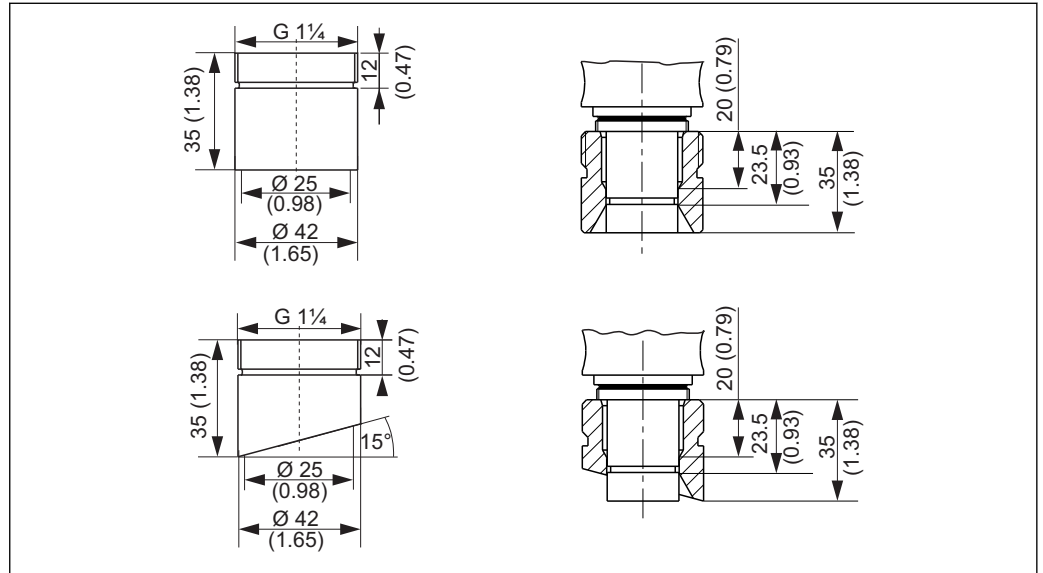

16 Weld-in adapter (safety nozzle), dimensions in mm (inch)

- Dummy plug G1¼, 1.4435 (AISI 316 L), FPM - FDA
- Sensor dummy 225 mm, 1.4435 (AISI 316 L), Ra = 0.38 µm
- Sensor dummy 360 mm, 1.4435 (AISI 316 L), Ra = 0.38 µm
- Kit, EPDM FDA seals only for process connection G1¼, wetted parts, single chamber
- Kit, FKM FDA seals only for process connection G1¼, wetted parts, single chamber
- Kit, FFKM FDA seals only for process connection G1¼, wetted parts, single chamber
- Kit, EPDM FDA seals, wetted parts, single chamber, not for process connection G1¼
- Kit, FKM FDA seals, wetted parts, single chamber, not for process connection G1¼
- Kit, FFKM FDA seals, wetted parts, single chamber, not for process connection G1¼
- Kit, EPDM FDA seals, wetted parts, double chamber, all process connections
- Kit, FKM FDA seals, wetted parts, double chamber, all process connections
- Kit, FFKM FDA seals, wetted parts, double chamber, all process connections
- Kit, seals not in contact with the medium
- Cable, plug-in, limit switch, M12, 5 m
- Cable, plug-in, limit switch, M12, 10 m
- Tool in case for installation/removal

Water filter and pressure reducer

Filter set CPC310, CVC400

- Water filter (dirt trap) 100 µm, complete, incl. angle bracket
- Order No. 71031661

Pressure reducer kit

- Complete, incl. manometer and angle bracket
- Order No. 51505755

Hose nozzle

Hose connection set G¼, DN 12

- 1.4404 (AISI 316L) 2 x
- Order No. 51502808

Hose connection set G¼, DN 12

- PVDF (2 x)
- Order No. 50090491

Sensors

pH sensors**Orbisint CPS11D / CPS11**

- pH electrode for process technology
- Optional SIL version for connecting to SIL transmitter
- With dirt-repellent PTFE diaphragm
- Product Configurator on the product page: www.endress.com/cps11d or www.endress.com/cps11



Technical Information TI00028C

Memosens CPS31D

- pH electrode with gel-filled reference system with ceramic diaphragm
- Product Configurator on the product page: www.endress.com/cps31d



Technical Information TI00030C

Ceraliquid CPS41D / CPS41

- pH electrode with ceramic junction and KCl liquid electrolyte
- Product Configurator on the product page: www.endress.com/cps41d or www.endress.com/cps41



Technical Information TI00079C

Ceragel CPS71D / CPS71

- pH electrode with double-chamber reference system and integrated bridge electrolyte
- Product Configurator on the product page: www.endress.com/cps71d or www.endress.com/cps71



Technical Information TI00245C

Orbipore CPS91D / CPS91

- pH electrode with open aperture for media with high dirt load
- Product Configurator on the product page: www.endress.com/cps91d or www.endress.com/cps91



Technical Information TI00375C

ORP sensors**Orbisint CPS12D / CPS12**

- ORP sensor for process technology
- Product Configurator on the product page: www.endress.com/cps12d or www.endress.com/cps12



Technical Information TI00367C

Ceraliquid CPS42D / CPS42

- ORP electrode with ceramic junction and KCl liquid electrolyte
- Product Configurator on the product page: www.endress.com/cps42d or www.endress.com/cps42



Technical Information TI00373C

Ceragel CPS72D / CPS72

- ORP electrode with double-chamber reference system and integrated bridge electrolyte
- Product Configurator on the product page: www.endress.com/cps72d or www.endress.com/cps72



Technical Information TI00374C

pH ISFET sensors**Tophit CPS441D / CPS441**

- Sterilizable ISFET sensor for low-conductivity media
- Liquid KCl electrolyte
- Product Configurator on the product page: www.endress.com/cps441d or www.endress.com/cps441



Technical Information TI00352C

Tophit CPS471D / CPS471

- Sterilizable and autoclavable ISFET sensor for food and pharmaceuticals, process engineering
- Water treatment and biotechnology
- Product Configurator on the product page: www.endress.com/cps471d or www.endress.com/cps471

 Technical Information TI00283C

Tophit CPS491D / CPS491

- ISFET sensor with open aperture for media with high dirt load
- Product Configurator on the product page: www.endress.com/cps491d or www.endress.com/cps491

 Technical Information TI00377C

pH and ORP combined sensors

Memosens CPS16D

- Combined pH/ORP sensor for process technology
- With dirt-repellent PTFE diaphragm
- With Memosens technology
- Product Configurator on the product page: www.endress.com/cps16d

 Technical Information TI00503C

Memosens CPS76D

- Combined pH/ORP sensor for process technology
- Hygienic and sterile applications
- With Memosens technology
- Product Configurator on the product page: www.endress.com/cps76d

 Technical Information TI00506C

Memosens CPS96D

- Combined pH/ORP sensor for chemical processes
- With poison-resistant reference with ion trap
- With Memosens technology
- Product Configurator on the product page: www.endress.com/cps96d

 Technical Information TI00507C

Conductivity sensor

Memosens CLS82D

- Four-electrode sensor
- With Memosens technology
- Product Configurator on the product page: www.endress.com/cls82d

 Technical Information TI01188C

Oxygen sensor

Oxymax COS22D / COS22

- Sterilizable sensor for dissolved oxygen
- With Memosens technology or as an analog sensor
- Product Configurator on the product page: www.endress.com/cos22d or www.endress.com/cos22

 Technical Information TI00446C

www.addresses.endress.com
