

# Operating Instructions

## Cleanfit CPA871

Flexible retractable process assembly for water, wastewater, chemical industry and heavy industry

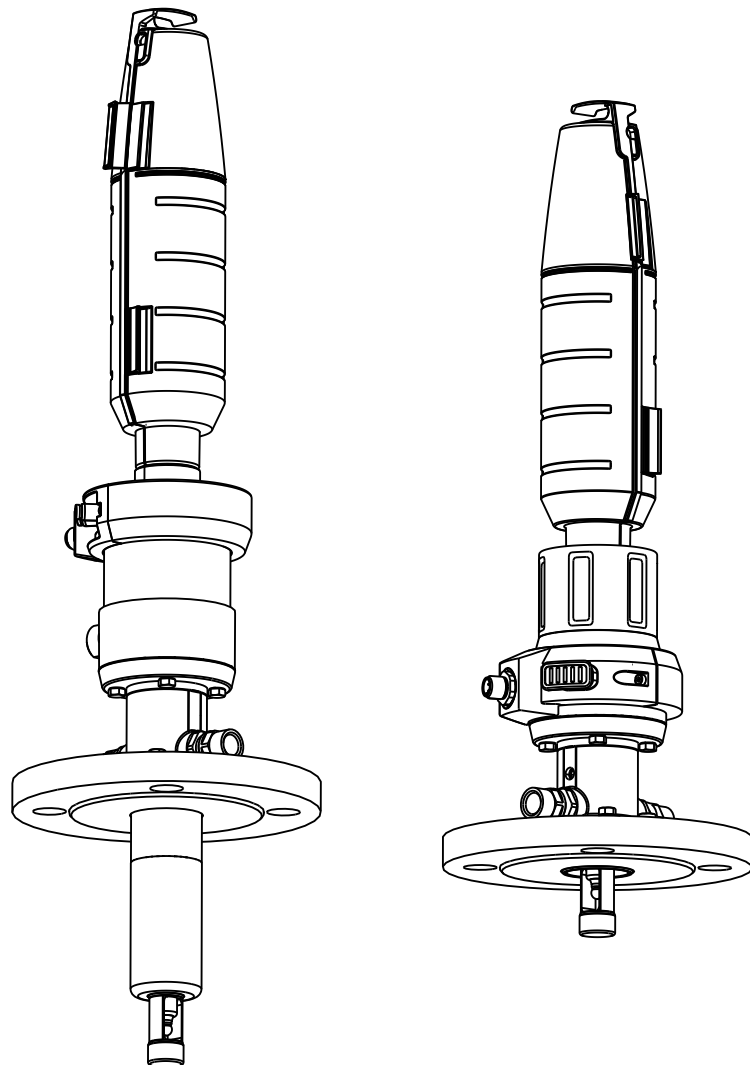





## Table of contents







<b>1</b>	<b>About this document</b> .....	<b>4</b>	10.3	Flow vessel .....	55
1.1	Warnings .....	4	10.4	Sensors .....	56
1.2	Symbols used .....	4	10.5	Absorption sensor .....	58
1.3	Symbols on the device .....	4			
<b>2</b>	<b>Basic safety instructions</b> .....	<b>5</b>	<b>11</b>	<b>Technical data</b> .....	<b>59</b>
2.1	Requirements for the personnel .....	5	11.1	Environment .....	59
2.2	Designated use .....	5	11.2	Process .....	59
2.3	Occupational safety .....	5	11.3	Mechanical construction .....	63
2.4	Operational safety .....	6			
2.5	Product safety .....	6			
<b>3</b>	<b>Product description</b> .....	<b>7</b>	<b>Index</b> .....		<b>64</b>
3.1	Product design .....	7			
<b>4</b>	<b>Incoming acceptance and product identification</b> .....	<b>9</b>			
4.1	Incoming acceptance .....	9			
4.2	Scope of delivery .....	9			
4.3	Product identification .....	10			
4.4	Certificates and approvals .....	11			
<b>5</b>	<b>Installation</b> .....	<b>12</b>			
5.1	Installation conditions .....	12			
5.2	Mounting the assembly .....	18			
5.3	Installing the sensor .....	26			
5.4	Post-installation check .....	31			
<b>6</b>	<b>Commissioning</b> .....	<b>32</b>			
<b>7</b>	<b>Operation</b> .....	<b>33</b>			
7.1	Adapting the assembly to the process conditions .....	33			
<b>8</b>	<b>Maintenance</b> .....	<b>36</b>			
8.1	Maintenance intervals .....	36			
8.2	Cleaning the assembly .....	38			
8.3	Cleaning the sensor .....	38			
8.4	Cleaning agent .....	39			
8.5	Replacing seals .....	40			
<b>9</b>	<b>Repair</b> .....	<b>52</b>			
9.1	Spare parts .....	52			
9.2	Return .....	52			
9.3	Disposal .....	52			
<b>10</b>	<b>Accessories</b> .....	<b>53</b>			
10.1	Installation material for rinse connections ...	54			
10.2	Cleaning systems .....	54			

# 1 About this document

## 1.1 Warnings

Structure of information	Meaning
 <b>DANGER</b> <b>Causes (/consequences)</b> If necessary, Consequences of non-compliance (if applicable) <ul style="list-style-type: none"> <li>▶ Corrective action</li> </ul>	This symbol alerts you to a dangerous situation. Failure to avoid the dangerous situation <b>will</b> result in a fatal or serious injury.
 <b>WARNING</b> <b>Causes (/consequences)</b> If necessary, Consequences of non-compliance (if applicable) <ul style="list-style-type: none"> <li>▶ Corrective action</li> </ul>	This symbol alerts you to a dangerous situation. Failure to avoid the dangerous situation <b>can</b> result in a fatal or serious injury.
 <b>CAUTION</b> <b>Causes (/consequences)</b> If necessary, Consequences of non-compliance (if applicable) <ul style="list-style-type: none"> <li>▶ Corrective action</li> </ul>	This symbol alerts you to a dangerous situation. Failure to avoid this situation can result in minor or more serious injuries.
<b>NOTICE</b> <b>Cause/situation</b> If necessary, Consequences of non-compliance (if applicable) <ul style="list-style-type: none"> <li>▶ Action/note</li> </ul>	This symbol alerts you to situations which may result in damage to property.

## 1.2 Symbols used

Symbol	Meaning
	Additional information, tips
	Permitted or recommended
	Not permitted or not recommended
	Reference to device documentation
	Reference to page
	Reference to graphic
	Result of a step

## 1.3 Symbols on the device

Symbol	Meaning
	Reference to device documentation

## 2 Basic safety instructions

### 2.1 Requirements for the personnel

- Installation, commissioning, operation and maintenance of the measuring system may be carried out only by specially trained technical personnel.
- The technical personnel must be authorized by the plant operator to carry out the specified activities.
- The electrical connection may be performed only by an electrical technician.
- The technical personnel must have read and understood these Operating Instructions and must follow the instructions contained therein.
- Faults at the measuring point may only be rectified by authorized and specially trained personnel.

 Repairs not described in the Operating Instructions provided must be carried out only directly at the manufacturer's site or by the service organization.

### 2.2 Designated use

The Cleanfit CPA871 retractable assembly, which can be manually or pneumatically operated, is designed for the installation of sensors in vessels and pipes.

Thanks to its design, it can be operated in pressurized systems (→  59).

Use of the device for any purpose other than that described, poses a threat to the safety of people and of the entire measuring system and is therefore not permitted.

The manufacturer is not liable for damage caused by improper or non-designated use.

#### 2.2.1 Use in explosion-proof areas

As a manufacturer of products used for analysis, we declare that the product supplied has undergone an ignition risk assessment and may be used in hazardous atmospheres once the following conditions for safe usage have been met:

- The protective ring is labeled as follows: "CAUTION, DANGER DUE TO ELECTROSTATIC CHARGES, CLEAN USING ONLY AN ANTISTATIC CLOTH". This instruction must be observed.
- Assemblies comprising wetted parts made of non-conductive material, must not be used in potentially explosive atmospheres.
- The compressed air supply, sensors and limit position switches must comply with the applicable guidelines and standards for use in hazardous atmospheres, be labeled with the degree of protection and meet the requirements of the relevant range of application. The ambient temperatures must be observed. The limit position switch used in the product complies with this requirement.
- Ensure that the compressed air does not contain a potentially explosive atmosphere.
- Care must be taken to ensure that movements during insertion and retraction of the sensor do not damage the connection.
- The product must be incorporated into the local potential equalization system.
- The Operating Instructions for the product and in particular the conditions for safe usage must be read, understood and implemented.

The product does not need to be labeled with the degree of protection.

### 2.3 Occupational safety

As the user, you are responsible for complying with the following safety conditions:

- Installation guidelines
- Local standards and regulations

## 2.4 Operational safety

### Before commissioning the entire measuring point:

1. Verify that all connections are correct.
2. Ensure that electrical cables and hose connections are undamaged.
3. Do not operate damaged products, and protect them against unintentional operation.
4. Label damaged products as defective.

### During operation:

- ▶ If faults cannot be rectified:  
products must be taken out of service and protected against unintentional operation.

## 2.5 Product safety

### 2.5.1 State of the art

The product is designed to meet state-of-the-art safety requirements, has been tested, and left the factory in a condition in which it is safe to operate. The relevant regulations and European standards have been observed.

## 3 Product description

### 3.1 Product design

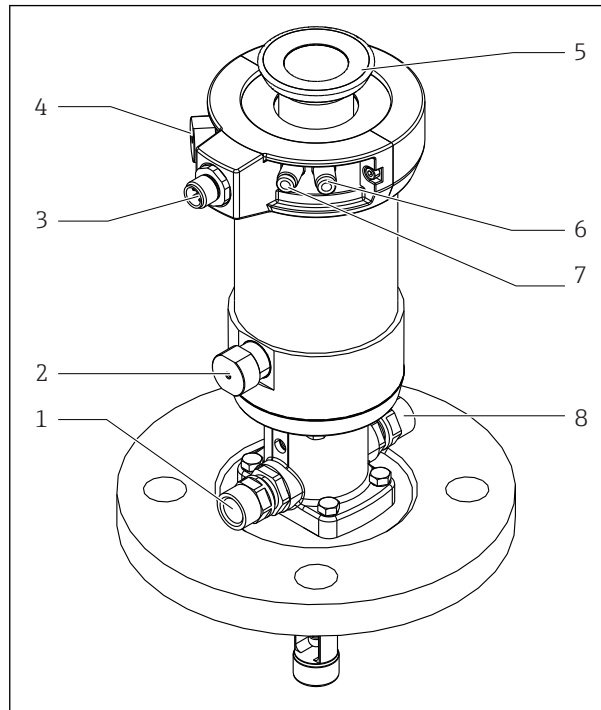

A0029614

1 Assembly with pneumatic drive (without protective cover)

- 1 Rinse connection (outlet)
- 2 Automatic limit position lock, process
- 3 Connection for limit position switch
- 4 Automatic limit position lock, service
- 5 Fastening ring for protective cover
- 6 Pneumatic connection (move to measuring position)
- 7 Pneumatic connection (move to service position)
- 8 Rinse connection (inlet)

### 3.1.1 Operating principle

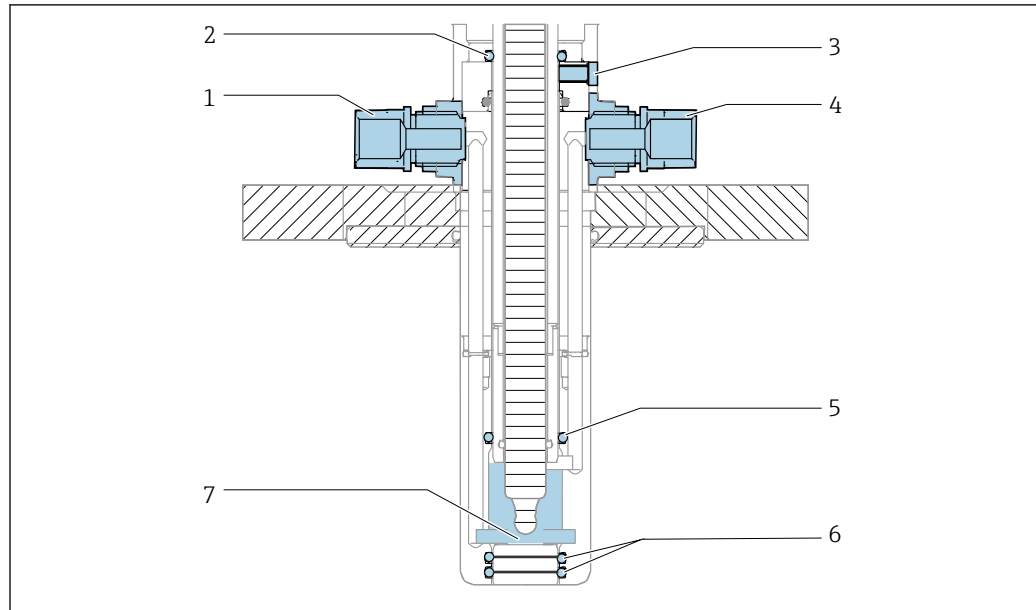

**2** Sealing system, assembly in service position

- 1 Rinse chamber, inlet
- 2 Seal, drive (1 x O-ring)
- 3 Leakage hole
- 4 Rinse chamber, outlet
- 5 Seal, rinse chamber (1 x O-ring)
- 6 Process seal (2 x O-ring)
- 7 Rinse chamber

The assembly is open to the process during insertion/retraction; the rinse connections must either be pipe-fitted or sealed.

The assembly has a pin seal. This seals the assembly from the process in the relevant limit position.

#### Process seal

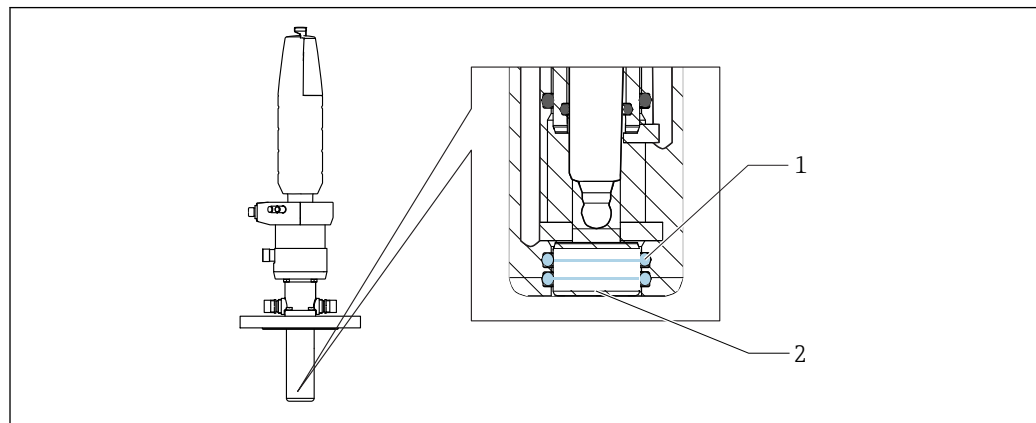

**3** Process seal, assembly in service position

- 1 Process seal (2 x O-ring)
- 2 Pin



## 4 Incoming acceptance and product identification

### 4.1 Incoming acceptance

1. Verify that the packaging is undamaged.
  - ↳ Notify the supplier of any damage to the packaging.  
Keep the damaged packaging until the issue has been resolved.
2. Verify that the contents are undamaged.
  - ↳ Notify the supplier of any damage to the delivery contents.  
Keep the damaged goods until the issue has been resolved.
3. Check that the delivery is complete and nothing is missing.
  - ↳ Compare the shipping documents with your order.
4. Pack the product for storage and transportation in such a way that it is protected against impact and moisture.
  - ↳ The original packaging offers the best protection.  
Make sure to comply with the permitted ambient conditions.

If you have any questions, please contact your supplier or your local Sales Center.

### 4.2 Scope of delivery

The scope of delivery comprises:

- Ordered version of assembly
- Operating Instructions
- Adapter push connector 6 mm (0.24 in) of 4 mm (0.16 in) (outer diameter)

## 4.3 Product identification

### 4.3.1 Nameplate

The nameplate provides you with the following information on your device:

- Manufacturer identification
- Order code
- Extended order code
- Serial number
- Ambient and process conditions
- Safety information and warnings

► Compare the information on the nameplate with the order.

### 4.3.2 Product identification

The order code and serial number of your product can be found in the following locations:

- On the nameplate
- In the delivery papers

#### Obtaining information on the product

1. Go to [www.endress.com](http://www.endress.com).
2. Call up the site search (magnifying glass).
3. Enter a valid serial number.
4. Search.
  - ↳ The product structure is displayed in a popup window.
5. Click on the product image in the popup window.
  - ↳ A new window (**Device Viewer**) opens. All of the information relating to your device is displayed in this window as well as the product documentation.

#### Product page

[www.endress.com/CPA871](http://www.endress.com/CPA871)

## 4.4 Certificates and approvals

### **CRN**

The design of the assembly was reviewed and registered by the Canadian safety authorities for all Canadian provinces in accordance with the requirements of the "Canadian Registration Number (CRN)" system.

### **ATEX- 2014/34/EU**

The assembly does not fall within the scope of the directive. However, if conditions for safe use are adhered to, it may be deployed in the hazardous area.

### **DRGL- 2014/68/EU / PED- 2014/68/EU**

The assembly has been manufactured according to good engineering practice as per Article 4, Paragraph 3 of the Pressure Equipment Directive 2014/68/EU and is therefore not required to bear the CE label.

## 5 Installation

### 5.1 Installation conditions

#### 5.1.1 Orientation

The assembly is designed for installation on tanks and pipes. Suitable process connections must be available for this.

#### **NOTICE**

##### **Frost damage to the assembly**

- ▶ If used outdoors, ensure that water cannot penetrate the drive.

The assembly is designed in such a way that there are no restrictions with regard to the orientation.



The sensor that is used can restrict the orientation.



Ensure compliance with the Operating Instructions of the sensor installed.

### 5.1.2 Dimensions

#### Short version

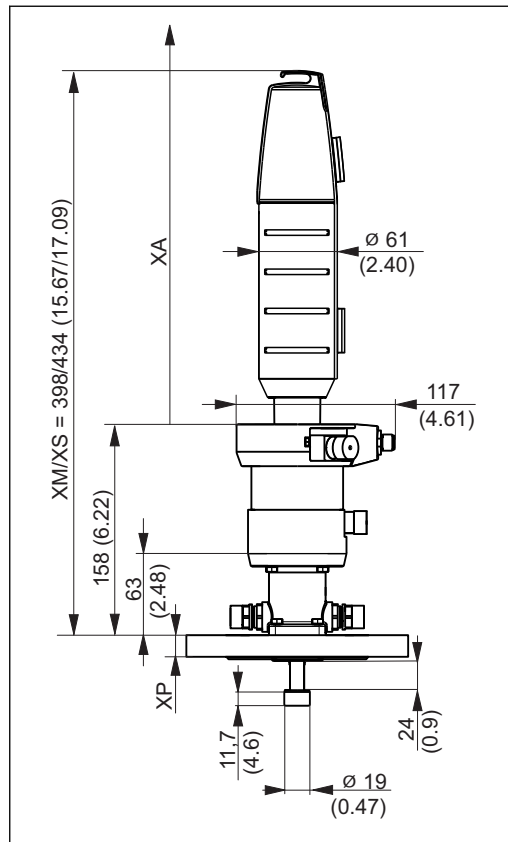

4 Pneumatic drive, short version, dimensions in mm (in)

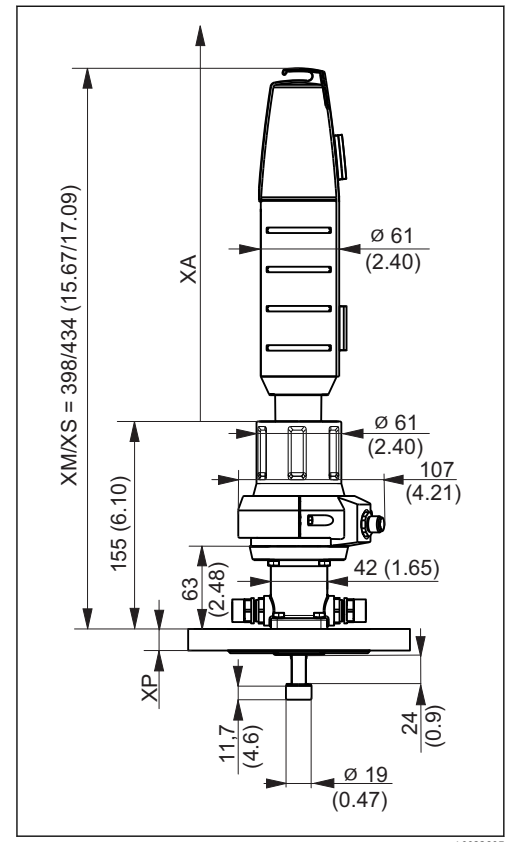

5 Manual drive, short version, dimensions in mm (in)

- XM* Assembly in measuring position
- XS* Assembly in service position
- XP* Height of particular process connection (see table below)
- XA* Necessary mounting distance for sensor replacement

The mounting distance XA is 280 mm (11.02") for 120 mm sensors  
 The mounting distance XA is 408 mm (15.94") for 225 mm sensors

Long version

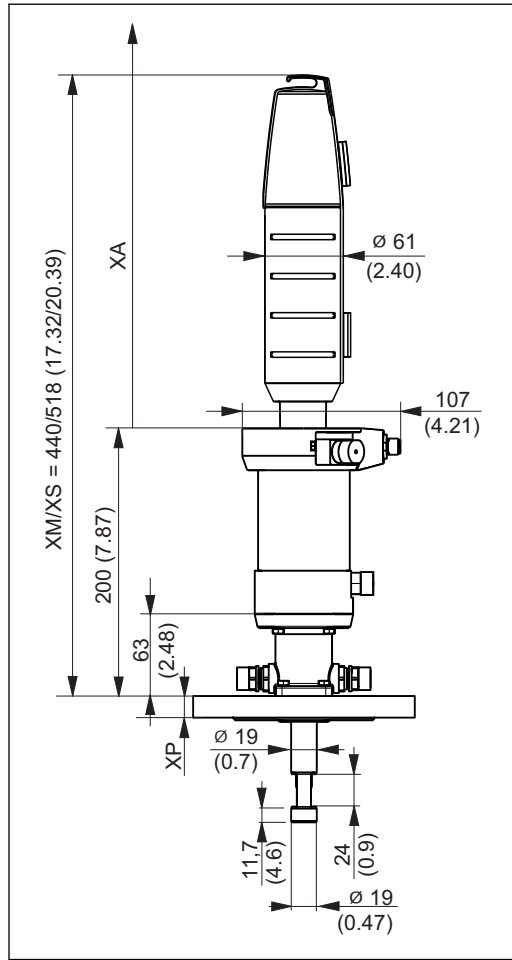

6 Pneumatic drive, long version, dimensions in mm (in)

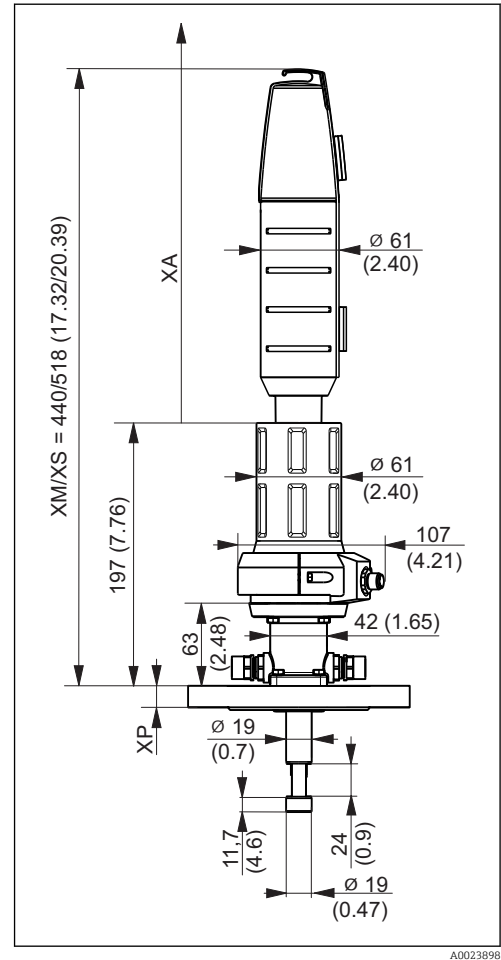

7 Manual drive, long version, dimensions in mm (in)

- XM Assembly in measuring position
- XS Assembly in service position
- XP Height of particular process connection (see table below)
- XA Necessary mounting distance for sensor replacement

The mounting distance XA is 360 mm (14.17") for 225 mm sensors

**Immersion chamber version**

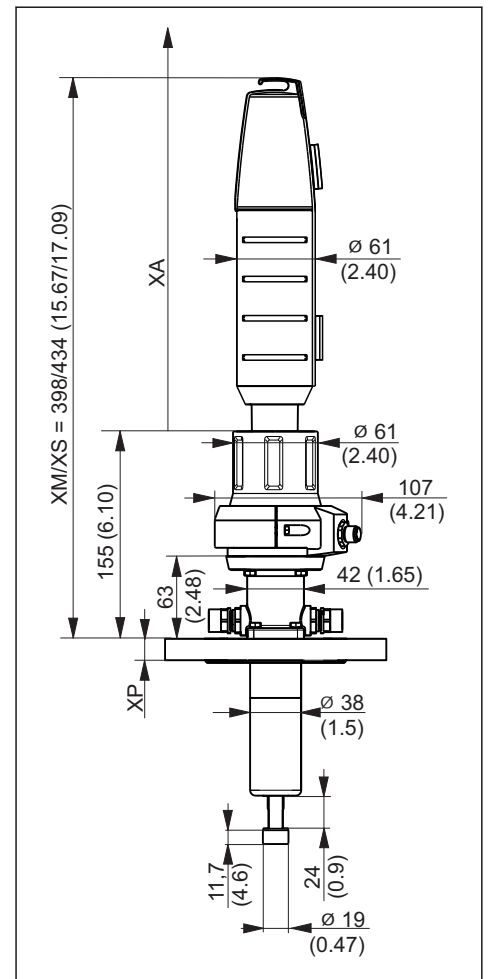
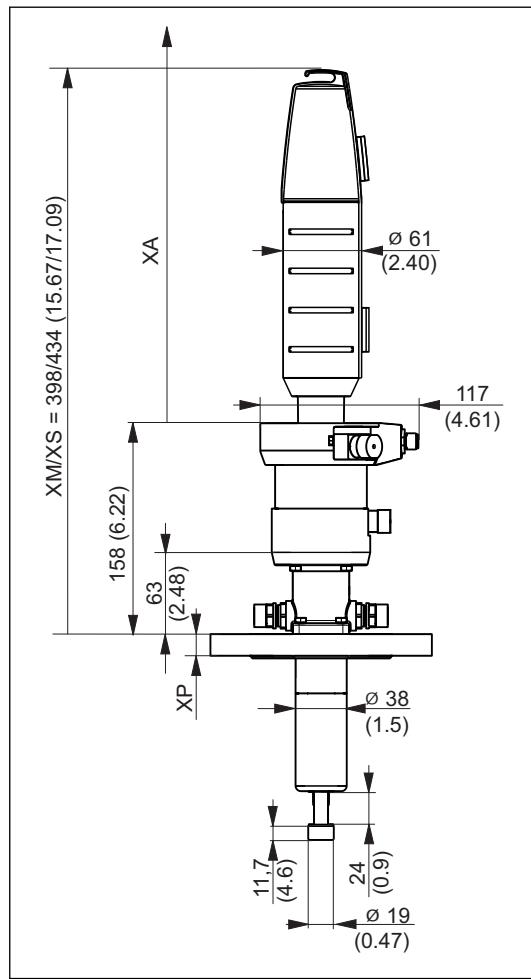

8 Immersion chamber version with pneumatic drive, dimensions in mm (in)

9 Immersion chamber version with manual drive, dimensions in mm (in)

*XM Assembly in measuring position*

*XS Assembly in service position*









*XP Height of particular process connection (see table below)*

*XA Necessary mounting distance for sensor replacement*

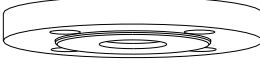
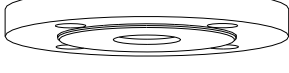
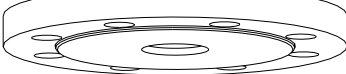
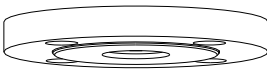
The mounting distance XA is 280 mm (11.02") for 225 mm sensors

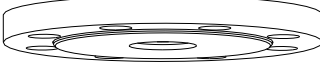
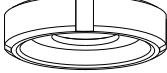
The mounting distance XA is 570 mm (22.44") for 360 mm sensors

## Process connection height

Process connection		Height XP in mm (in)
<b>CB</b> Clamp 2" ISO2852, ASME BPE-2012	 A0024100	16 (0.63)
<b>CC</b> Clamp 2½" ISO2852, ASME BPE-2012	 A0024101	16 (0.63)
<b>FA</b> Flange DN 40 PN16, EN1092-1	 A0024102	18 (0.71)
<b>FB</b> Flange DN 50 PN16, EN1092-1	 A0024103	18 (0.71)
<b>FC</b> Flange DN 80 PN10, EN1092-1	 A0024104	20 (0.79)
<b>FD</b> Flange 2" 150 lbs, ASME B16.5	 A0024105	19.1 (0.75)
<b>FE</b> Flange 3" 150 lbs, ASME B16.5	 A0024106	23.8 (0.94)
<b>FF</b> 10K50, JIS B2220	 A0024107	16 (0.63)
<b>FG</b> 10K80, JIS B2220	 A0024108	18 (0.71)
<b>MA</b> Dairy fitting DN 50 DIN 11851	 A0024109	15.5 (0.61)
<b>MB</b> Dairy fitting DN 65 DIN 11851	 A0024110	15.5 (0.61)
<b>HB</b> Thread NPT 1½"	 A0024111	40.5 (1.57)
<b>NA</b> Thread ISO 228 G1¼	 A0039368	31.1 (1.22)



### 5.1.3 Immersion depths

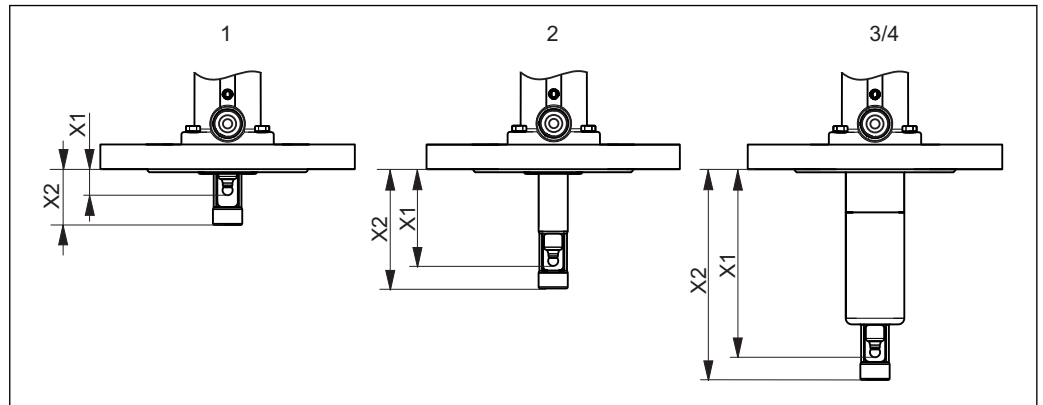

A0023893

10 Immersion depths in mm (in)

- 1 Short stroke, 36 mm (1.42 in)
- 2 Long stroke, 78 mm (3.07 in)
- 3 Immersion version

#### Versions

Process connection		1	2	3	4
CB Clamp ISO2852 ASME BPE-2012 2"	X1	14.9 (0.59)	61.0 (2.40)	119.9 (4.72)	171.9 (6.76)
	X2	34.2 (1.35)	75.7 (2.98)	134.6 (5.30)	186.6 (7.35)
CC Clamp ISO2852 ASME BPE-2012 2½"	X1	14.9 (0.59)	61.0 (2.40)	119.9 (4.72)	171.9 (6.76)
	X2	34.2 (1.35)	75.7 (2.98)	134.6 (5.30)	186.6 (7.35)
FA Flange DN 40 EN1092-1	X1	14.9 (0.59)	61.0 (2.40)	119.9 (4.72)	171.9 (6.76)
	X2	34.2 (1.35)	75.7 (2.98)	134.6 (5.30)	186.6 (7.35)
FB Flange DN 50 EN1092-1	X1	14.9 (0.59)	61.0 (2.40)	119.9 (4.72)	171.9 (6.76)
	X2	34.2 (1.35)	75.7 (2.98)	134.6 (5.30)	186.6 (7.35)
FC Flange DN 80 EN1092-1	X1	12.9 (0.51)	59.0 (2.32)	117.9 (4.64)	169.9 (6.69)
	X2	32.2 (1.27)	73.7 (2.90)	132.6 (5.22)	184.6 (7.27)
FD Flange 2" 150 lbs ASME B16.5	X1	13.8 (0.54)	59.9 (2.36)	118.8 (4.68)	170.9 (6.73)
	X2	33.1 (1.30)	74.6 (2.94)	133.5 (5.26)	185.6 (7.30)
FE Flange 3" 150 lbs ASME B16.5	X1	-	-	114.1 (4.49)	166.1 (6.54)
	X2	-	-	128.8 (5.07)	180.8 (7.11)
FF Flange 10K50 JIS B2220	X1	14.4 (0.57)	61.3 (2.41)	120.2 (4.73)	172.2 (6.78)
	X2	33.7 (1.33)	76.0 (2.99)	134.9 (5.31)	186.9 (7.36)
FG Flange 10K80 JIS B2220	X1	14.4 (0.57)	60.5 (2.38)	119.4 (4.70)	171.4 (6.75)
	X2	33.7 (1.33)	75.2 (2.96)	134.1 (5.28)	186.1 (7.33)
HB Thread NPT 1½"	X1	-	63.0 (2.48)	121.9 (4.80)	173.9 (6.85)
	X2	-	77.7 (3.06)	136.6 (5.38)	188.6 (7.40)
MA Dairy fitting DN 50 DIN 11851	X1	15.4 (0.61)	61.5 (2.42)	120.4 (4.74)	172.4 (6.79)
	X2	34.7 (1.37)	76.2 (3.00)	135.1 (5.32)	187.1 (6.37)
MB Dairy fitting DN 65 DIN 11851	X1	15.4 (0.61)	61.5 (2.42)	120.4 (4.74)	172.4 (6.79)
	X2	34.7 (1.37)	76.2 (3.00)	135.1 (5.32)	187.1 (6.37)
NA Thread ISO 228 G 1¼"	X1	-	61.5 (2.42)	-	-
	X2	-	76.2 (3.00)	-	-
	X3	-	20.6 (0.81)	-	-

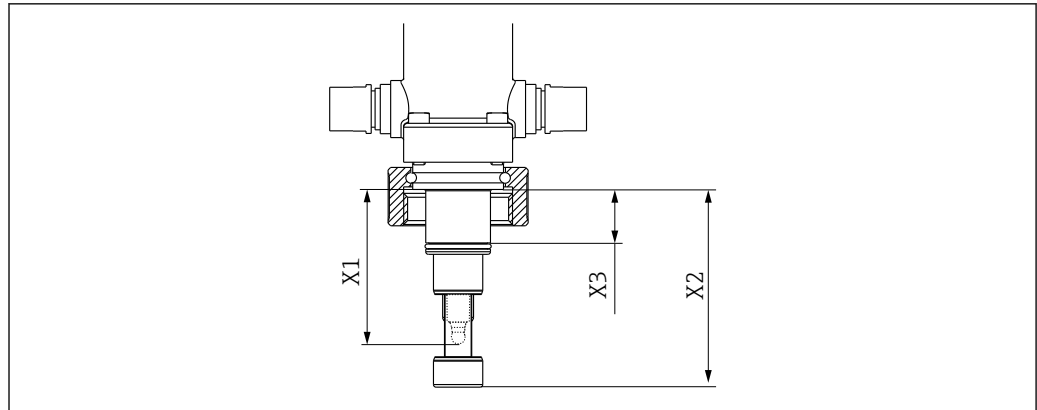

A0039342

11 Immersion depth in mm (in) for process connection NA thread ISO 228 G1¼

## 5.2 Mounting the assembly

### 5.2.1 Installation

#### Measuring system

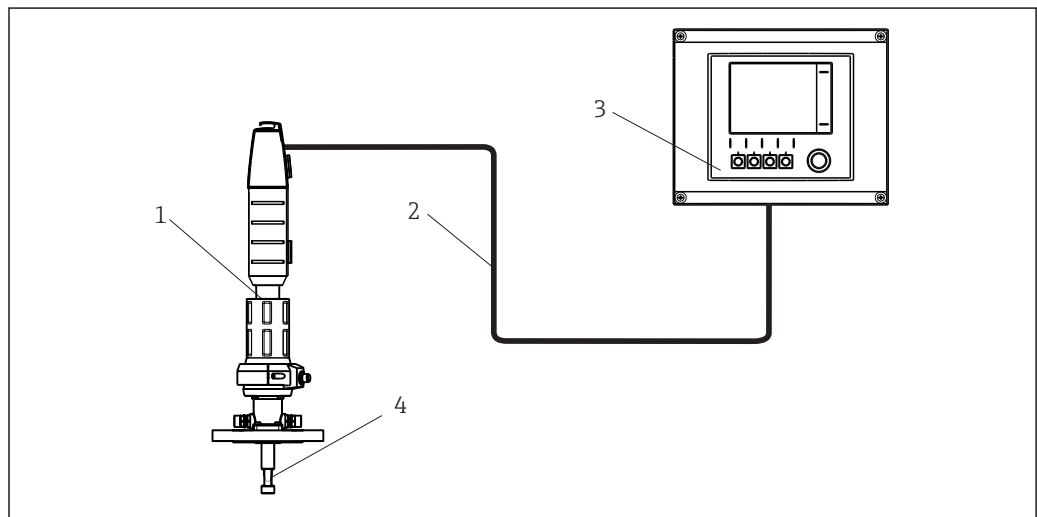

A0029620

12 Measuring system (example)

- 1 Cleanfit assembly CPA871
- 2 Measuring cable
- 3 Liquiline CM44x transmitter
- 4 Sensor

#### Installation recommendation

The two O-rings of the process seal close off the process in the relevant limit position. The assembly is open to the process during insertion/retraction; the rinse connections must either be pipe-fitted or sealed.

**i** The connection between the service chamber and the process is open during movement; the sealing water function can be used as a result. The rinse chamber outlet must be blocked (e.g., with a shutoff valve) to implement the sealing water function.

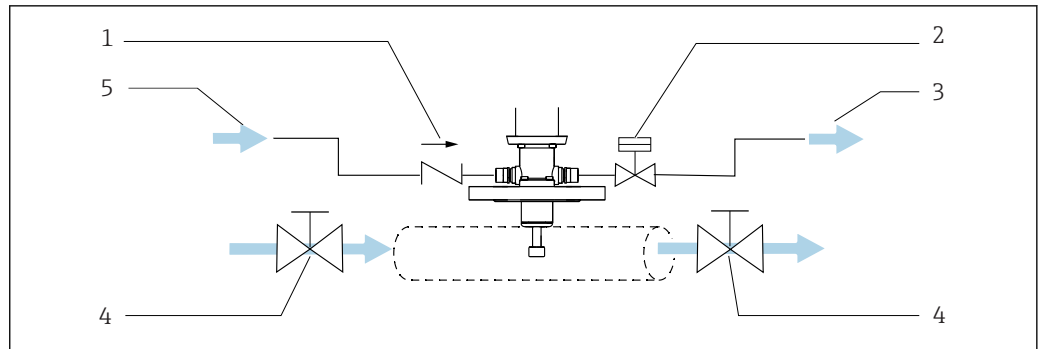

13 Sealing system using a bypass

- 1 Check valve
- 2 Valve open/closed, sealing water function
- 3 Wastewater
- 4 Shutoff valve open/closed
- 5 Water/cleaning agent

The seals must be checked and serviced regularly. Therefore measures must be taken to separate the assembly from the process, e.g., by installing a bypass.

### Installing/removing the assembly from the process

#### **⚠ WARNING**

**Risk of injury from high pressure, high temperature or chemical hazards if process medium escapes.**

- ▶ Wear protective gloves, protective goggles and protective clothing.
- ▶ Mount the assembly only if vessels or pipes are empty and unpressurized.

**i** Prior to installation, check the flange seal between the flanges.

1. Move the assembly to the service position.  
↳ (The triangle position marking is visible (→  14)).
2. Secure the assembly on the tank or piping via the process connection.
3. Follow the instructions in the next section to connect pipes for compressed air and rinse water (for the relevant assembly version).

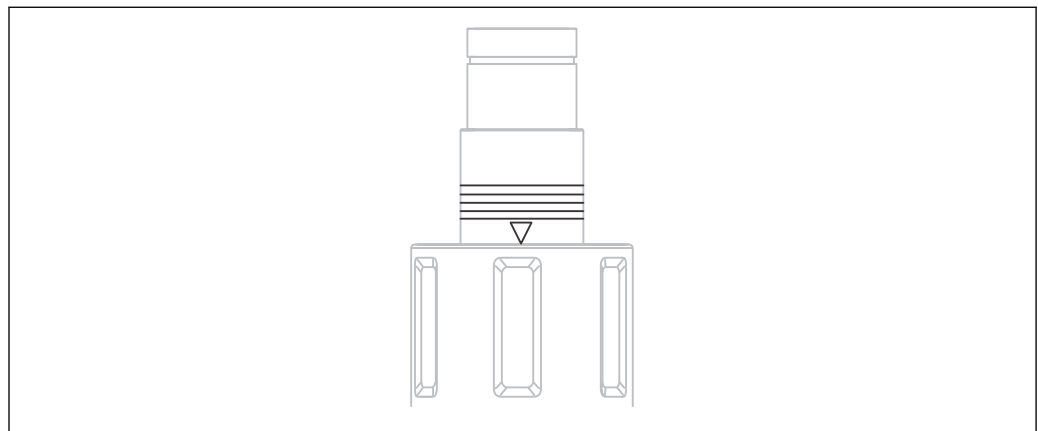

A0023307

 14 Position markings (service position)

### Pneumatic connection for automatic operation

Prerequisites:

- Air pressure 4 to 7 bar (absolute pressure) (58 to 102 psi)
- Compressed air quality in accordance with ISO 8573-1:2001  
Quality class 3.3.3 or 3.4.3
- Solids class 3 (max. 5 µm, max. 5 mg/m<sup>3</sup>, contamination with particles)
- Water content for temperatures ≥ 15 °C: Class 4 pressure condensation point 3 °C or lower
- Water content for temperatures of 5 to 15 °C: Class 3 pressure condensation point -20 °C or lower
- Oil content: Class 3 (max. 1 mg/m<sup>3</sup>)
- Air temperature: 5 °C or higher
- No continuous air consumption
- Minimum nominal diameter of air pipes: 2 mm (0.08 ")

A dual-operating cylinder is used to operate the pneumatic drive.

An automatic limit position lock both in service and measuring position secures the assembly to prevent it from moving inadvertently in the event of a failure in the control air. The assembly remains in the relevant position.

Connection: Push connector M5, hose 4/2 mm OD/ID (adapter for 6/4 mm OD/ID enclosed)

#### NOTICE

#### Air pressure too high

Damage to seals.

- ▶ Connect a pressure-reducing valve upstream if the air pressure is likely to rise to above 7 bar (absolute pressure) (102 psi) (even short pressure surges).

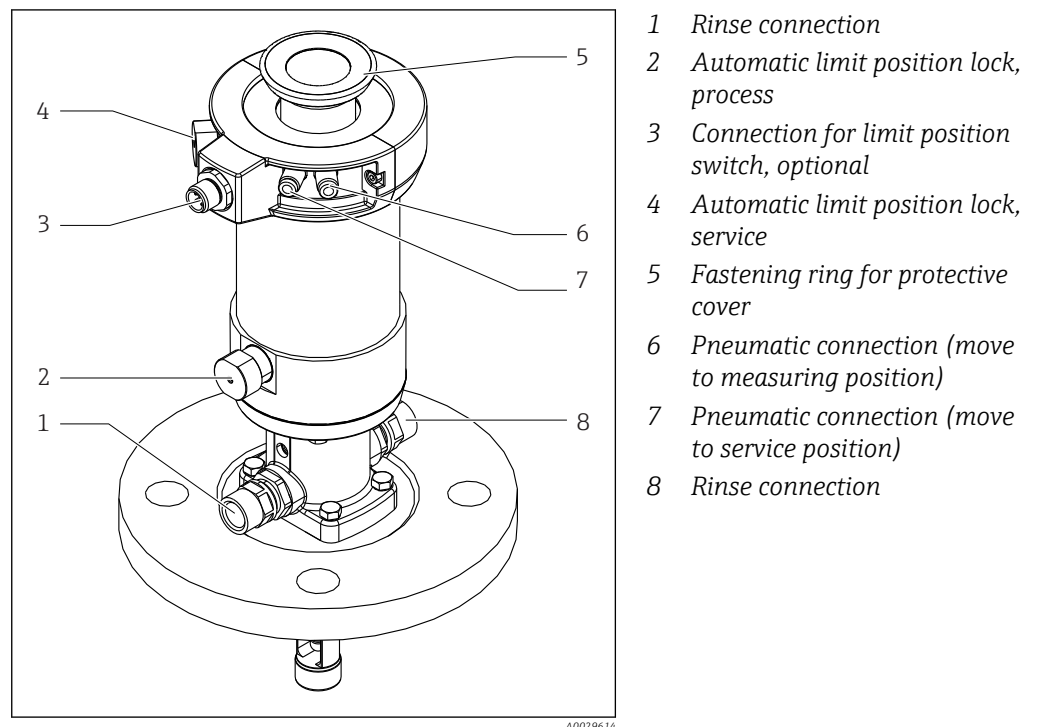

15 Assembly with pneumatic drive (without protective cover)

- i** Use a pneumatic pilot valve to insert/retract the assembly (4/2-way or 5/2-way valve). Connect both inputs.

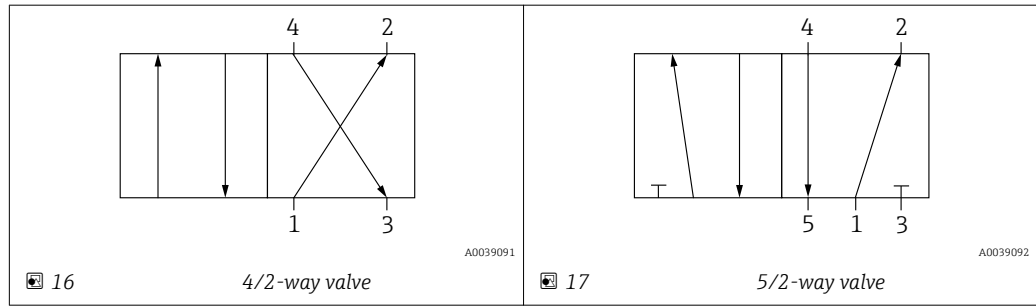

Connection 1 is attached to the compressed air supply.

Connections 2 and 4 are used to attach to the pneumatic drive.

Connection 3 and, if present, connection 5 are not attached; they are used to vent the drive.

### Rinse connections

The service chamber connections make it possible to rinse the chamber (including the sensor) with water or cleaning solution. The pressure difference between the sealing water and process must not exceed 6 bar (87 psi).

The sealing water pressure must not exceed 8 bar (116 psi) in manual mode and 16 bar (232 psi) in pneumatic mode.

**i** Install a pressure-reducing valve upstream if there is a possibility that the sealing water pressure will increase to more than (8 bar (116 psi) or 16 bar (232 psi)) (including any short pressure surges).

### NOTICE

**Pressure difference too high between process and wastewater system or if rinse connections are not properly connected.**

Damage to seals

- ▶ Close rinse connections.
- ▶ Pipe-fit rinse connections.
- ▶ Use sealing water function.

### Assignment of rinse connections

In the standard and immersion chamber version, the inlet and outlet of the service chamber are fixed. The outlet of the service chamber is located under the leakage hole. The leakage hole is sealed with an M5 screw.

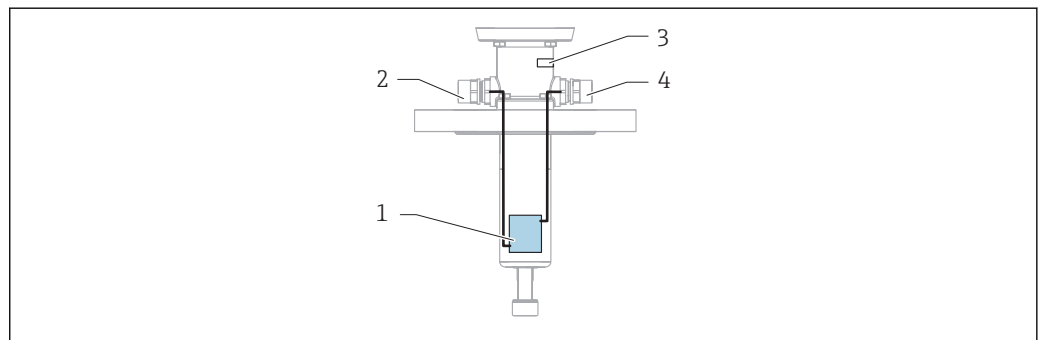

**18** Connection of service chamber in the immersion chamber version

- 1 Service chamber
- 2 Service chamber inlet, IN
- 3 Leakage hole
- 4 Service chamber outlet, OUT

### Leakage hole, with optional connection (accessories)

Used for visual inspection.

If medium leaks out:

1. Switch off the process
2. Replace the seals

### Connecting the limit position switches

With limit position detection, you can notify a system located downstream (transmitter, switching amplifier, output interface terminal) whether the assembly is in the measuring or service position (in the case of manual drive, only the measuring position is queried).

The limit position switches must be connected to output interface terminals (can be ordered as accessories) to enable power supply.

The assembly can be ordered directly with limit position detection, or it can be retrofitted at a later stage. The cable for the limit position switches must be ordered as an accessory.

### Feedback signals

The feedback signals are intrinsically safe. The approval for the feedback signals is no longer valid if they are not installed or connected correctly.

1. Ensure full compliance with manufacturer documentation.
2. Connect the feedback signals in accordance with the relevant instructions.

Switching element function:	NAMUR NC contact (inductive)
Switching distance:	1.5 mm (0.06 ")
Nominal voltage:	8 V DC
Switching frequency:	0 to 5000 Hz
Housing material:	Stainless steel

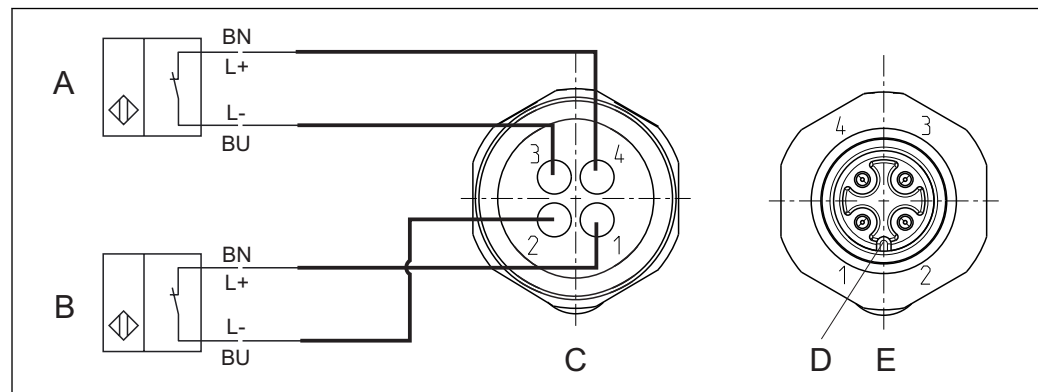

A0017831

19 Inductive limit position switches

- A Limit position switch, service position  
 B Limit position switch, measuring position  
 C Connector, M12, solder side (inside of assembly)  
 D Coding  
 E Connector, pin side (outside of assembly)



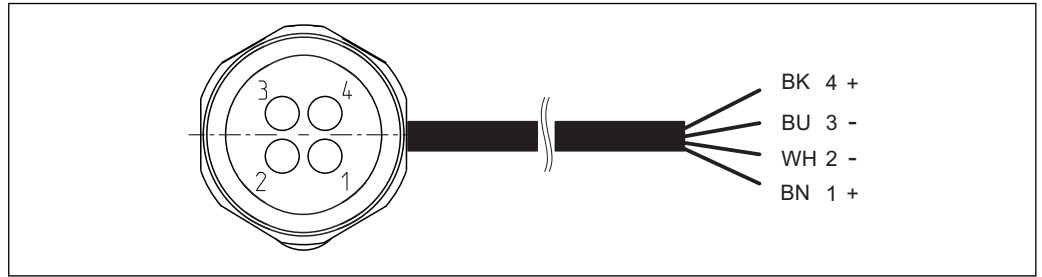

A0022163

20 Connecting cable for limit position switch on transmitter, switching amplifier, output interface terminal etc.

- 1 Measuring position
- 2 Measuring position
- 3 Service position
- 4 Service position

**i** Only pins 1 and 2 are assigned for manually activated assemblies with one switch (measuring position).

**i** NAMUR terminal (8 V DC) and connecting cable with blue marking available as accessories.

Signal table for limit position switches

Position of assembly	Limit position switch, measuring position	Limit position switch, service position
Measuring	Active LOW ( $\geq 3$ mA)	Active LOW ( $\geq 3$ mA)
Service	Active HIGH ( $\leq 1$ mA)	Active HIGH ( $\leq 1$ mA)

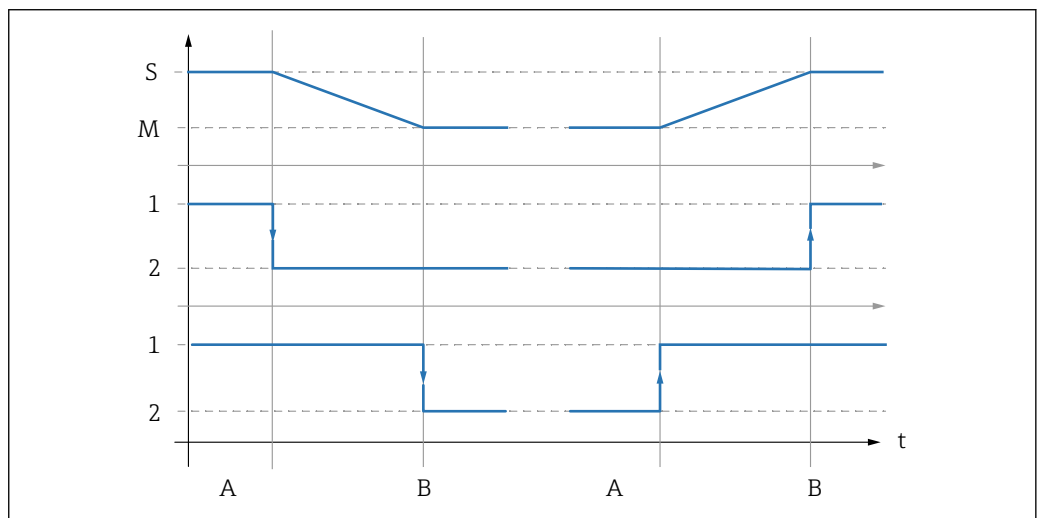

A0039144

21 Description of switching function

- S Service
- M Measuring
- 1 High
- 2 Low
- A Movement starts
- B Limit position reached

## 5.3 Installing the sensor

### 5.3.1 Preparing the sensor and assembly

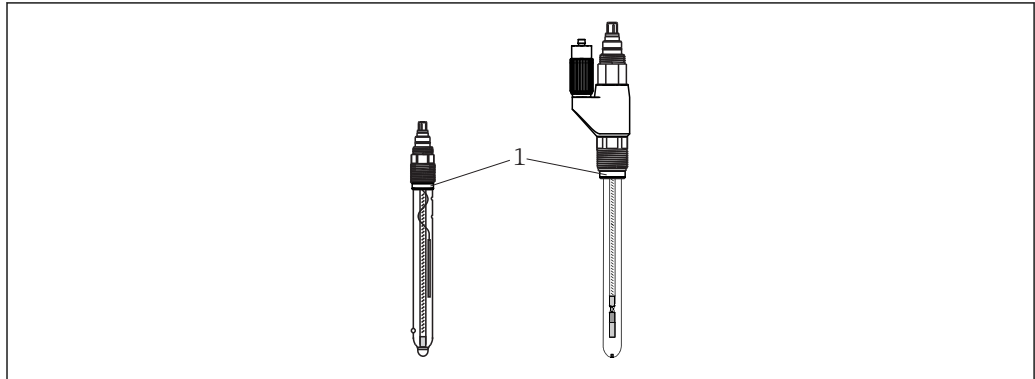

A0030154

📄 22 *Installing the sensor*

1 *Thrust collar with O-ring*

1. Remove protection cap from sensor. Ensure that O-ring and thrust collar (→ 📄 22, pos. 1) are present.
2. Submerge sensor shaft in water. This makes for easier installation.
3. Move the assembly to the service position.

### 5.3.2 Installing and removing sensors

#### **⚠️ WARNING**

#### **Risk resulting from temperature, pressure and chemical composition!**

- ▶ Before removing, clean and rinse the sensor adequately in the rinse chamber.
- ▶ Check process seals. (There can be no leakage of medium from the rinse chamber in limit position when rinsing is disabled)

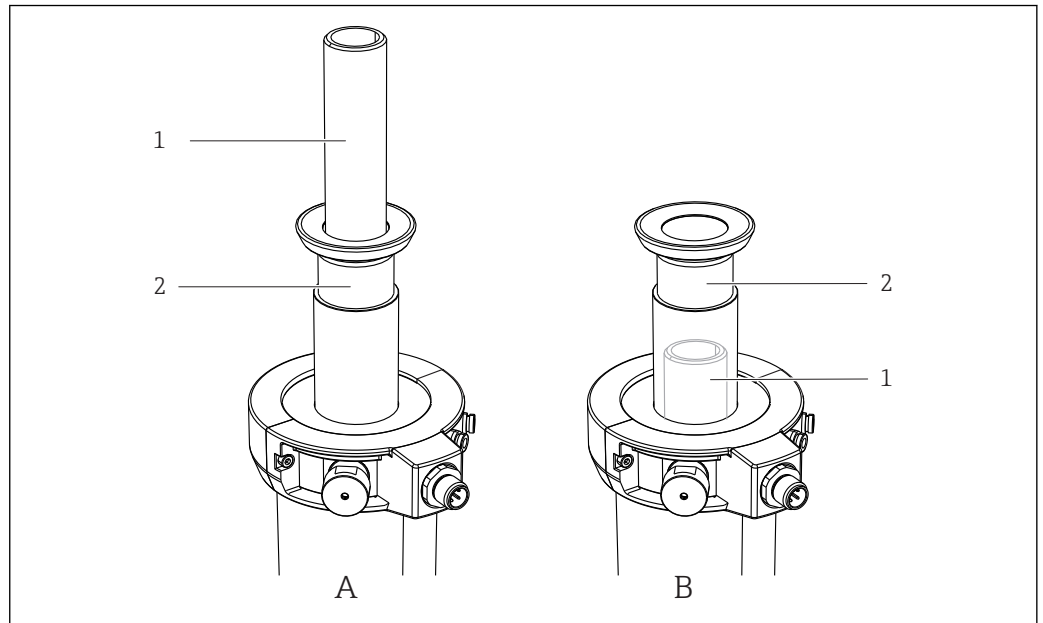

A0030155

23 Sensor installation options

1 Sensor adapter

2 Retraction pipe

A Sensor adapter is on top of the retraction pipe

B Sensor adapter is below the retraction pipe (not visible)

Depending on the assembly version, the sensor adapter is either visible (, pos. A) or installed inside the retraction pipe where it is not visible (pos. B). As a result, the procedures for installing and removing the sensors differ as follows:

### Installing and removing sensors if the sensor adapter is visible (A)

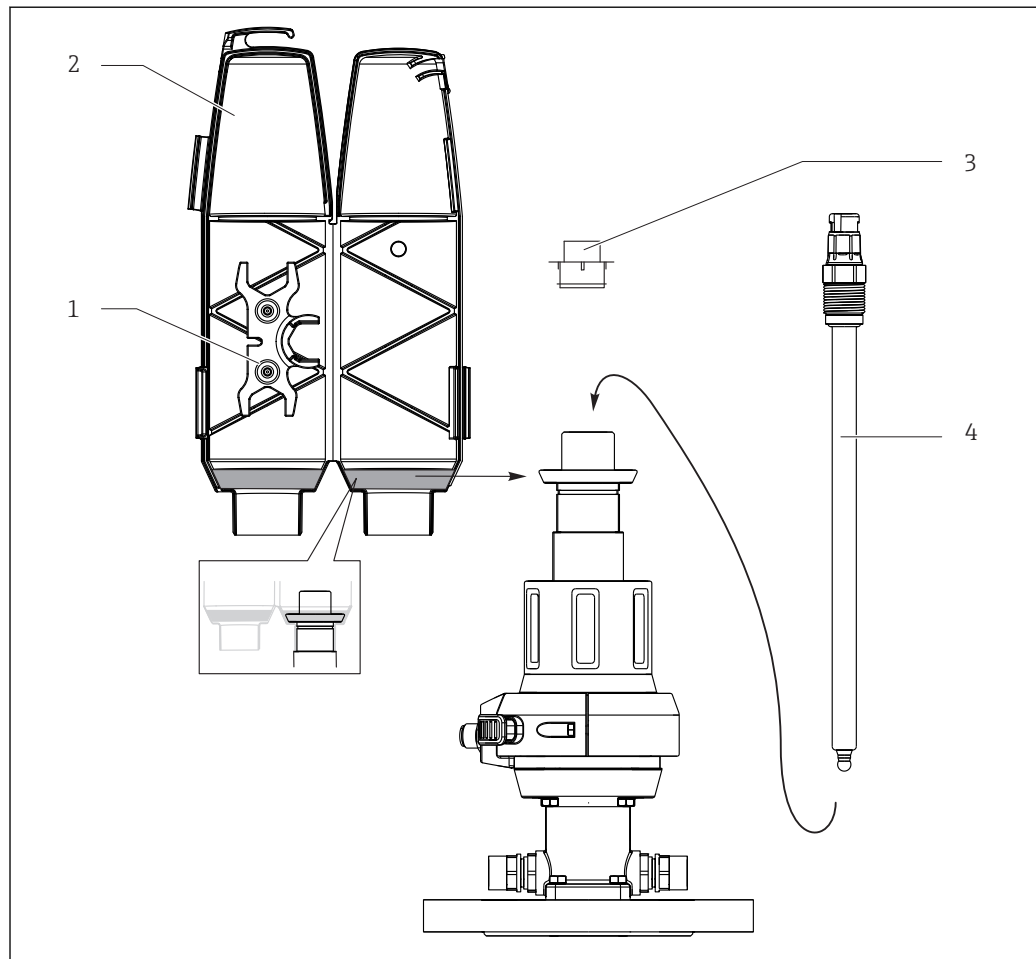

A0030156

#### 24 Installing the sensor

- 1 Open-ended wrench (AF 17/19 mm)
- 2 Protective cover
- 3 Dummy plug
- 4 Sensor

**i** Gel and KCl sensors can be installed in this version.

Install the sensor as follows:

1. Remove the protective cover (→ 24, pos. 2) (this is only possible if the assembly is in service position).
2. Remove the yellow dummy plug (pos. 3).
3. Use the open-ended wrench (pos. 1) to screw in the sensor (pos. 4) in place of the dummy plug and hand-tighten (3 Nm (2.2 lbf ft)).
4. Attach the open-ended wrench back into the protective cover.
5. Mount the protective cover on the assembly. When doing so, guide the measuring cable through the cable run (top of protective cover).

**i** Always install the protective cover before moving the assembly to measuring position. The protective cover cannot be removed in measuring position. This prevents the sensor from being removed.

### Installing and removing sensors if the sensor adapter is not visible (pos. B)

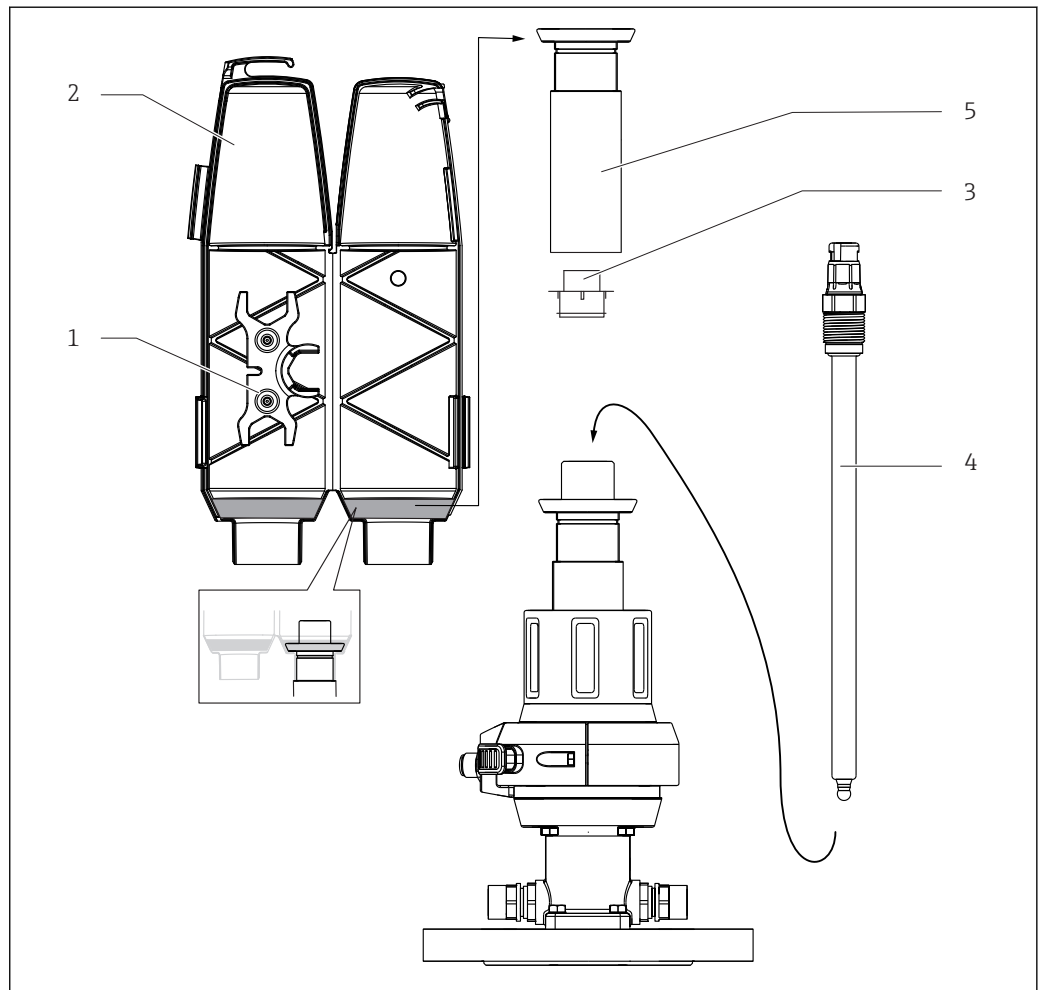

A0030157

#### 25 Installing the sensor

- 1 Socket wrench (AF 17/19 mm)
- 2 Protective cover
- 3 Dummy plug (protection cap)
- 4 Sensor
- 5 Retraction pipe

**i** Gel sensors can be installed in this version. To install KCl sensors, you will need a "Gel - KCl adapter".

Install the sensor as follows:

1. Remove the protective cover (→ 25, pos. 2) (this is only possible if the assembly is in service position).
2. Unscrew the retraction pipe (pos. 5) in a counterclockwise direction.
3. Remove the yellow dummy plug (pos. 3).
4. Using the open-ended wrench (pos. 1), screw in the sensor (pos. 4) in place of the dummy plug and hand-tighten (3 Nm (2.2 lbf ft)).
5. Screw in the retraction pipe again.
6. Attach the open-ended wrench back into the protective cover.



5. Screw in the "Gel - KCl adapter" (pos. 6) in place of the dummy plug and hand-tighten (3 Nm (2.2 lbf ft)).
6. Hand-tighten the lock nut in a clockwise direction, and then use an open-ended wrench (AF 24 mm) to tighten it by ¼ turn.
7. Screw the retraction pipe back in.
8. Use the open-ended wrench (pos. 1) to screw in the sensor (→  27, pos. 4) and hand-tighten (3 Nm (2.2 lbf ft)).
9. Attach the open-ended wrench back into the protective cover.
10. Mount the protective cover on the assembly. When doing so, guide the measuring cable through the cable run (top of protective cover).

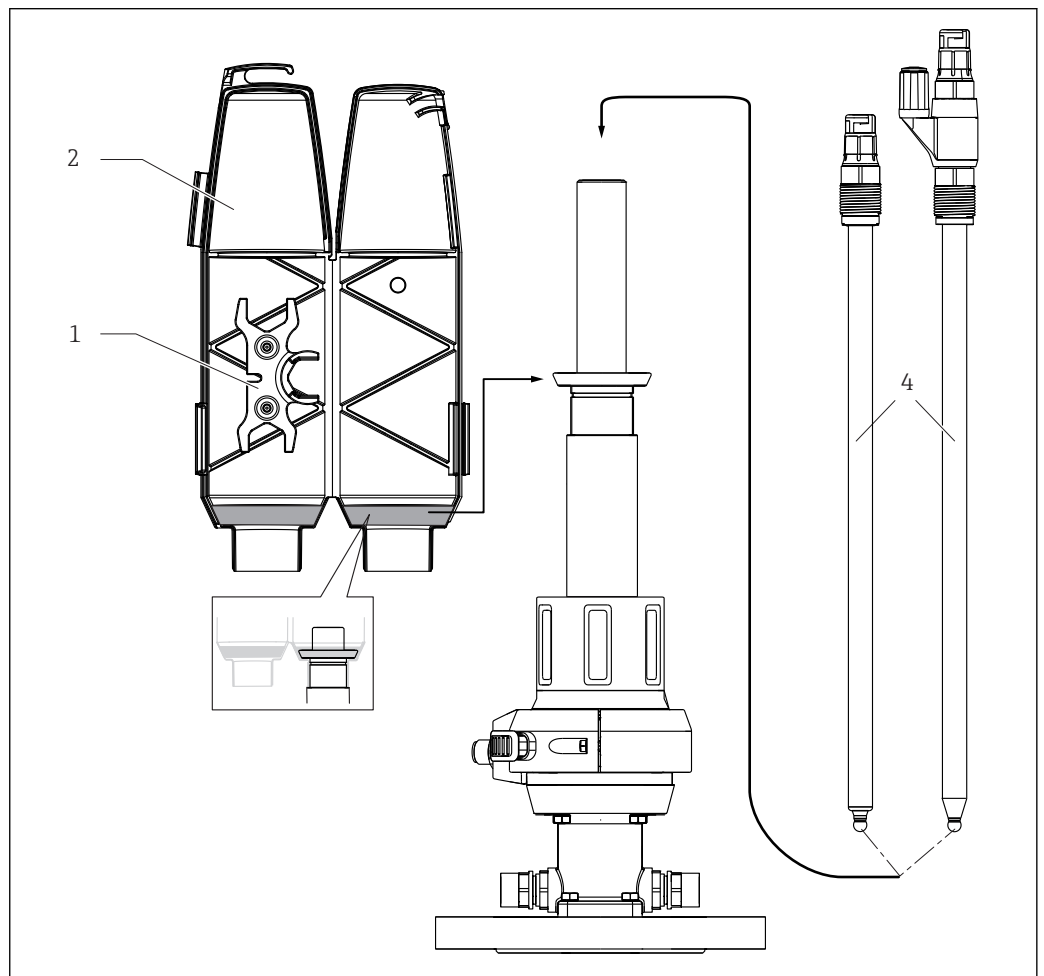

 27 Sensor installation, Part 2

- 1 Open-ended wrench
- 2 Protective cover
- 4 360 mm gel or KCl sensor

 Always install the protective cover before moving the assembly to measuring position. The protective cover cannot be removed in measuring position. This prevents the sensor from being removed.

## 5.4 Post-installation check

Put the sensor into operation only if you can answer "yes" to the following questions:

- Are the sensor and cable undamaged?
- Is the orientation correct?
- Is the sensor installed in an assembly and not suspended from the cable?

## 6 Commissioning

Before commissioning, ensure that:

- all seals are correctly seated (on the assembly and on the process connection).
- the sensor is correctly installed and connected.
- the water connection at the rinse connections is correct (if present) or the rinse connections are sealed.

### WARNING

**Risk of injury from high pressure, high temperature or chemical hazards if process medium escapes.**

- ▶ Check the connections to ensure they are sealed tightly.

### WARNING

**Process medium may escape during insertion/retraction of the assembly.**

- ▶ Check that the process seal is intact.
- ▶ Pipe-fit the rinse chamber outlet accordingly.

 Note that when the assembly is inserted/retracted, an open connection exists for a short period between the process and service chamber.



## 7 Operation

### 7.1 Adapting the assembly to the process conditions

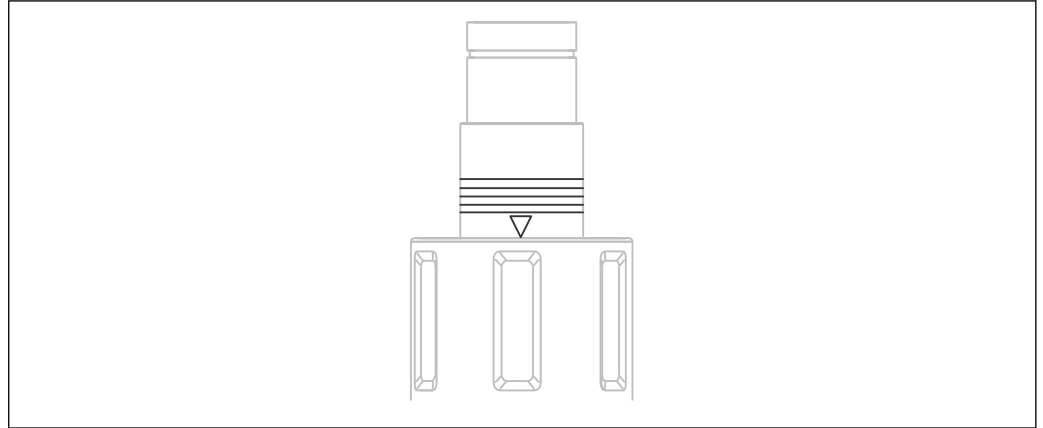

A0023307

▣ 28 Position markings (service position)

#### Assembly with pneumatic drive

The assembly with pneumatic drive does not have any operating elements.

#### Assembly with manual drive

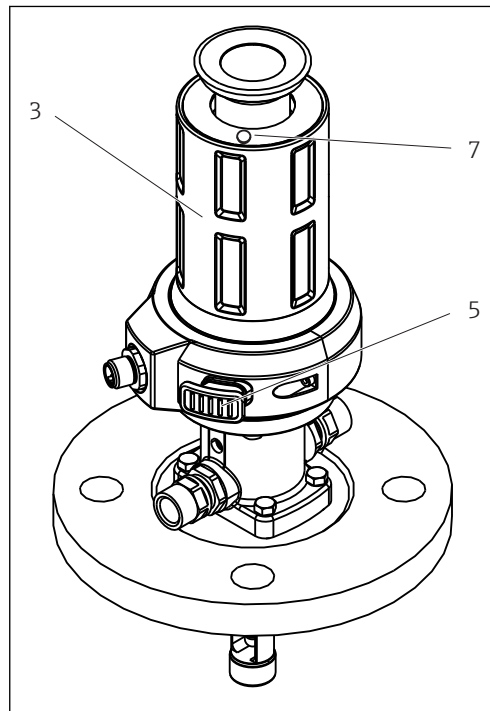

A0030305

▣ 29 Operating elements

- 3 Manual drive
- 5 Unlocking button (measuring position)
- 7 Unlocking button (service position)

### 7.1.1 Manual operation

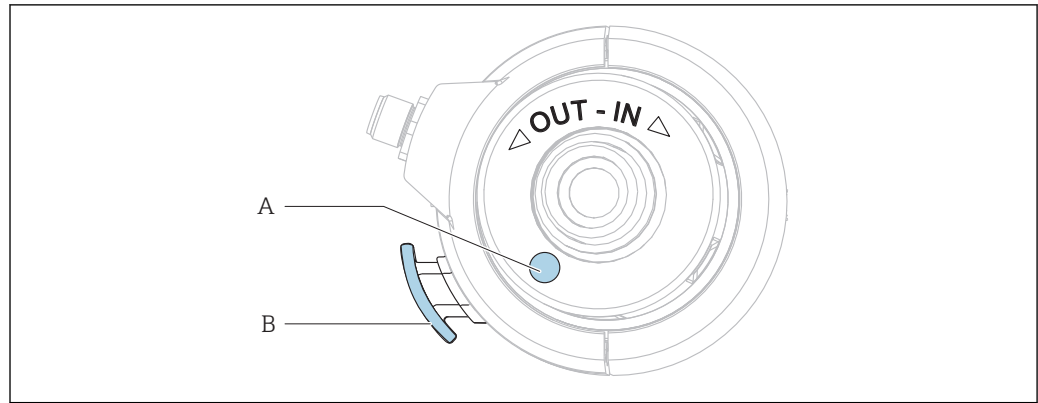

30 Direction of rotation

- A Unlocking button (service position)  
 B Unlocking button (measuring position)

#### Moving the assembly from the service position to the measuring position

1. Press the unlocking button (A).
2. With the unlocking button (A) pressed during the first quarter turn, rotate the drive in a clockwise direction so that the sensor holder moves into the process (only possible with the sensor installed). The button can be released while turning the rest of the way.
3. Rotate the drive until the lock engages.

#### Moving the assembly from the measuring position to the service position

1. Press the unlocking button (B).
2. With the unlocking button (B) pressed during the first quarter turn, rotate the drive in a counterclockwise direction until the stop (service position).
3. Perform the required service activities.

### 7.1.2 Pneumatic operation

The assembly can only be inserted/retracted if a sensor is installed.

Operation of the pneumatic version depends on the controller in question. The Operating Instructions can be found in the manual for the controller.

Use a pneumatic pilot valve (4/2-way or 5/2-way) to insert/retract the assembly.

- ▶ Connect the two inputs.
  - ↳ If only input is connected (e.g., for test purposes), the piston is blocked as the sensor guide moves before the limit position lock is disabled.

### Inserting/retracting the assembly if the compressed air supply fails

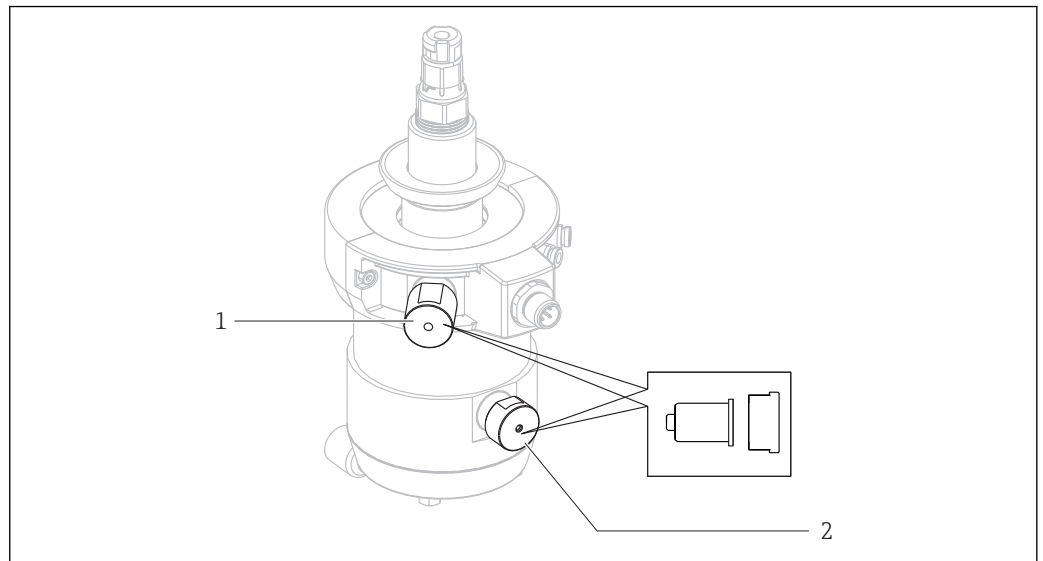

#### 31 Failure of compressed air supply

- 1 Limit position lock for service position
- 2 Limit position lock for measuring position

#### **CAUTION**

#### Risk of injury due to high medium pressure

- Depressurize the system.

If the compressed air supply fails, you can still move the assembly manually. Proceed as follows here:

1. Use an open-ended wrench (AF 17 mm) to unscrew both limit position locks (pos. 1 and 2).
2. Remove the internal component.
3. If the internal component is stuck (if an attempt was made to insert/retract the assembly without deactivating the limit position lock), move the assembly to the respective limit position manually.
4. Move the assembly to the desired position.
5. Screw the limit position lock back in.

## 8 Maintenance

### WARNING

#### Risk of injury if medium escapes

- ▶ Before each maintenance task, ensure that the process pipe is empty and rinsed.
- ▶ Move the assembly to service position.
- ▶ The assembly may contain residual medium; please rinse thoroughly before commencing work.

 The assembly drive is maintenance-free. It is not possible to carry out maintenance or repair work on the drive.

### 8.1 Maintenance intervals

 A maintenance log is recommended to adapt to the correct maintenance intervals.

 The specified intervals serve as a guide. For harsh process or ambient conditions, it is recommended that the intervals be reduced accordingly. Cleaning intervals for the sensor and assembly are dependent on the medium.

 Following cleaning or replacement, apply a generous layer of Klüber XPC0003-V+R8 grease to the seals.

Interval	Maintenance measures
Regularly	Visual inspection: <ul style="list-style-type: none"> <li>▶ Check that all connections are sealed tightly.</li> </ul> Check for tightness: <ul style="list-style-type: none"> <li>▪ Rinse lines</li> <li>▪ Process connections</li> <li>▪ Compressed air hoses (pneumatic drive).</li> </ul> Clean the process seal using the sealing water function: <ul style="list-style-type: none"> <li>▶ Close the rinse chamber outlet.</li> <li>▶ Rinse in the process in order to clean the seals.</li> </ul>
Monthly or after 500 strokes (whichever comes first)	<ul style="list-style-type: none"> <li>▶ Check that the process seal is intact.</li> <li>▶ Replace the seals if medium is escaping.</li> <li>▶ Check the leakage hole. Remove the screw to do this.</li> </ul> <p>Does medium escape from the leakage hole when the assembly is moving? This may indicate that the internal O-rings in the service chamber are defective.</p> <ol style="list-style-type: none"> <li>1. Check the leakage hole of the service chamber.</li> <li>2. Remove the screw on top of the rinse chamber outlet, there should be no leakage of medium.</li> </ol> <ol style="list-style-type: none"> <li>1. Inspect the sensor.</li> <li>2. Disassemble the sensor.</li> <li>3. Check the sensor for deposits.</li> <li>4. If deposits are present, check cleaning cycle (cleaning agents, temperature, duration, flow volume).</li> </ol> <p>When process pressure is applied and cleaning disabled, there should be no discharge of medium from the assembly's rinse chamber outlet.</p> <ul style="list-style-type: none"> <li>▶ Check for defective process seal(s).</li> </ul>

Interval	Maintenance measures
Biannually or after 5000 strokes (whichever comes first)	<ul style="list-style-type: none"><li>▶ Clean the assembly thoroughly.</li><li>▶ Remove the residual medium.</li><li>▶ Replace all seals in contact with the medium.</li></ul> <ol style="list-style-type: none"><li>1. Check mobility of retraction protection.</li><li>2. Remove the sensor.<ul style="list-style-type: none"><li>↳ The contact surface of the sensor in the assembly is spring-loaded and must be free to move.</li></ul></li></ol> <p>Possible cause of failure: Contamination inside the drive, e.g., caused by a broken sensor.</p>

## 8.2 Cleaning the assembly



### WARNING

#### Risk of injury if medium escapes

- ▶ Before each maintenance task, ensure that the process pipe is empty and rinsed.
- ▶ Move the assembly to service position.
- ▶ The assembly may contain residual medium; please rinse thoroughly before commencing work.
  
- ▶ For stable and reliable measurements, clean the assembly and the sensor regularly. The frequency and intensity of the cleaning process depend on the medium.

### 8.2.1 Manually operated assembly

All parts in contact with the medium, such as the sensor and the sensor guide, must be cleaned regularly.

1. Remove the sensor in the reverse order to installation. →  26
2. Remove light dirt and fouling with suitable cleaning solutions. (→  39)
3. Remove heavy soiling using a soft brush and a suitable cleaning agent.
4. For very persistent dirt, soak the parts in a cleaning solution. Then clean the parts with a brush.

 A typical example of a cleaning interval would be 6 months in the case of drinking water.

### 8.2.2 Pneumatically controlled assembly

Regular, pneumatically controlled cleaning is recommended using the rinse water connection and the appropriate equipment.

## 8.3 Cleaning the sensor

→ Documentation of the connected sensor

1. Always clean ORP electrodes mechanically and with water.
2. Do not use chemical cleaning agents.
  - ↳ Such cleaning agents cause a potential to build up at the electrode which takes a few hours to dissipate. The potential causes errors in the measurement.
3. Do not use abrasive cleaning agents.
  - ↳ These can cause irreparable damage to the sensor.
4. Perform another calibration following cleaning if necessary.

Clean the sensor:

- Before every calibration
- Regularly during operation
- Before returning it for repairs

You can remove the sensor and clean it manually, or you can clean it in automatic mode <sup>1)</sup> using the rinse water connection.

1) only if the assembly is fitted out accordingly

## 8.4 Cleaning agent

### **⚠ WARNING**

#### **Organic solvents containing halogens**

Limited evidence of carcinogenicity! Dangerous for the environment with long-term effects!

- ▶ Do not use organic solvents that contain halogens.

### **⚠ WARNING**

#### **Thiocarbamide**

Harmful if swallowed! Limited evidence of carcinogenicity! Possible risk of harm to the unborn child! Dangerous for the environment with long-term effects!

- ▶ Wear protective goggles, protective gloves and appropriate protective clothing.
- ▶ Avoid all contact with the eyes, mouth and skin.
- ▶ Avoid discharge into the environment.

The most common types of soiling and the cleaning agents used in each case are shown in the following table.

Type of soiling	Cleaning agent
Greases and oils	Hot water or tempered (alkaline) agents containing surfactants or water-soluble organic solvents (e. g. ethanol)
Limescale deposits, metal hydroxide buildup, lyophobic biological buildup	Approx. 3% hydrochloric acid
Sulfide deposits	Mixture of 3% hydrochloric acid and thiocarbamide (commercially available)
Protein buildup	Mixture of 3% hydrochloric acid and pepsin (commercially available)
Fibers, suspended substances	Pressurized water, possibly surface-active agents
Light biological buildup	Pressurized water

- ▶ Choose a cleaning agent to suit the degree and type of soiling.

## 8.5 Replacing seals

To replace the seals in the assembly, you must interrupt the process and remove the assembly completely.

### CAUTION

#### **Risk of injury due to residual medium and elevated temperatures**

- ▶ When handling parts that are in contact with the medium, protect against residual medium and elevated temperatures. Wear protective goggles and safety gloves.
- ▶ Clean the assembly prior to replacing seals. (→  38)

#### **Preparation:**

1. Interrupt the process. Pay attention to residual medium, residual pressure as well as elevated temperatures.
2. Move the assembly to service position.
3. Completely detach the assembly from the process connection.
4. Clean the assembly. (→  38)



## 8.5.1 Standard version

### Seal replacement in the process connection

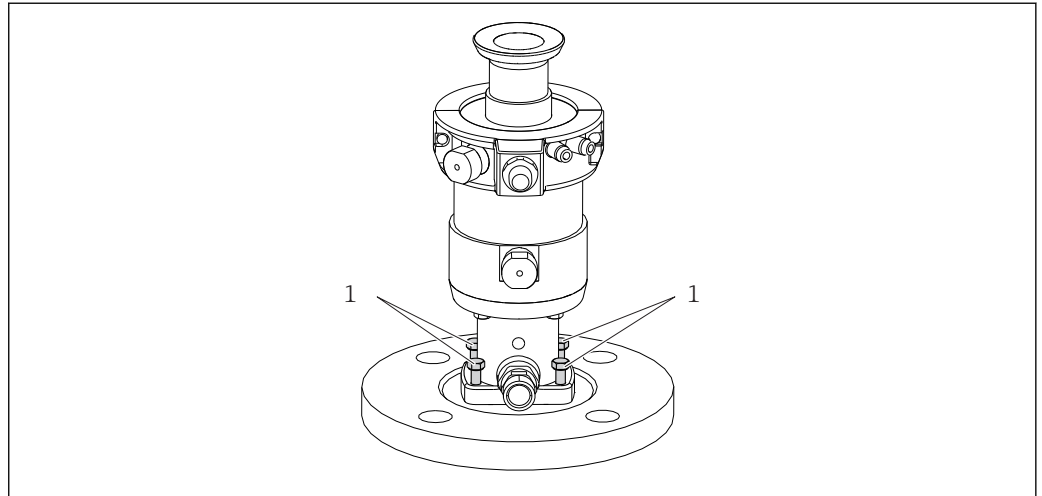

A0030290

#### 32 Replacing seals, Part 1

1 Securing screws AF8

1. Release the four securing screws (pos. 1).

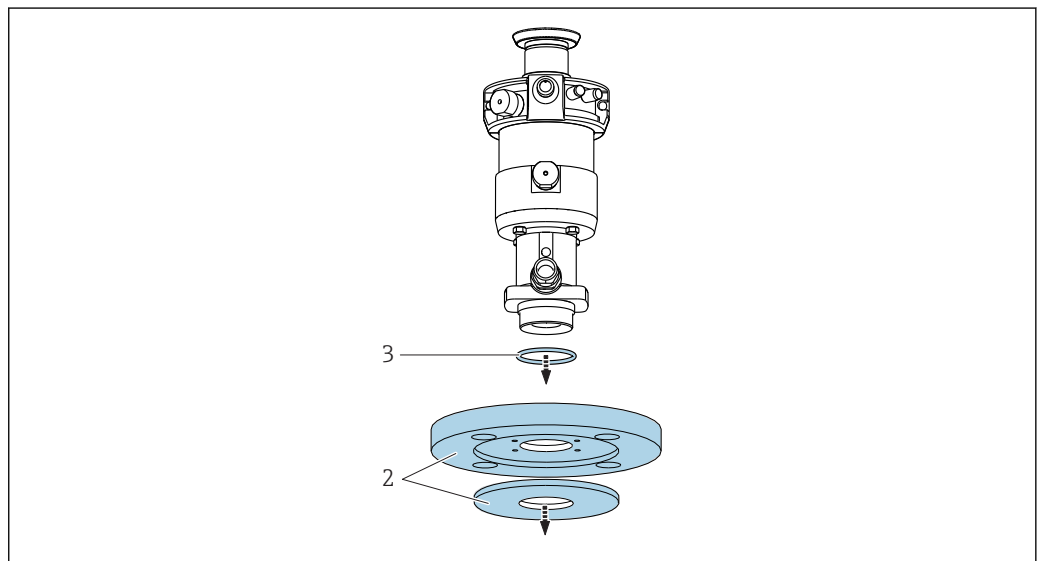

A0030291

#### 33 Replacing seals, Part 2

2 Process connection

3 O-ring in process connection

2. Remove the process connection (pos. 2).
3. Remove the O-ring (pos. 3) from the process connection (gasket).
4. Apply a thin layer of grease to the new O-ring (e.g., Klüber Paraliq GTE 703).
5. Insert the O-ring into the process connection.

### Seal replacement in the rinse connection

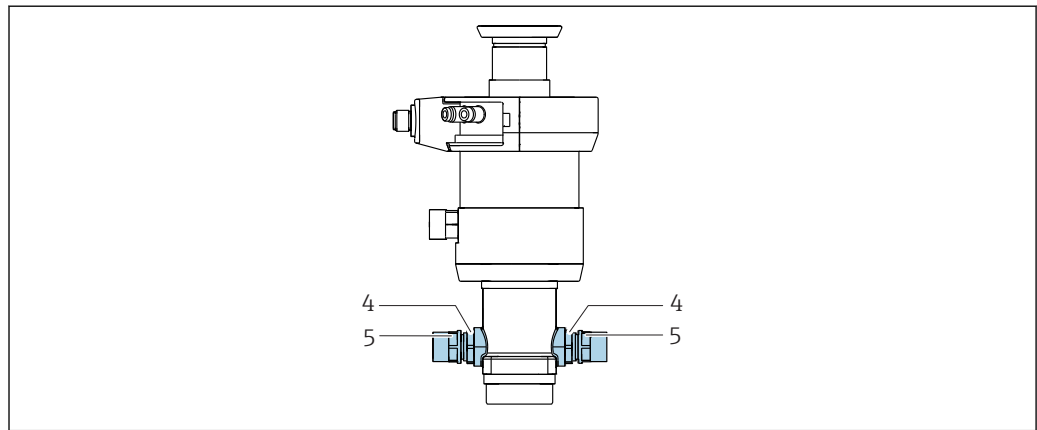

A0030292

#### 34 Replacing seals, Part 3

4 Lock nut

5 Rinse connection adapter

1. Release the lock nuts (pos. 4) using an open-ended wrench or socket wrench (AF 19 mm, in protective cover).
2. Unscrew the two rinse connection adapters (pos. 5) using an open-ended wrench or socket wrench (AF 17 mm, in protective cover).

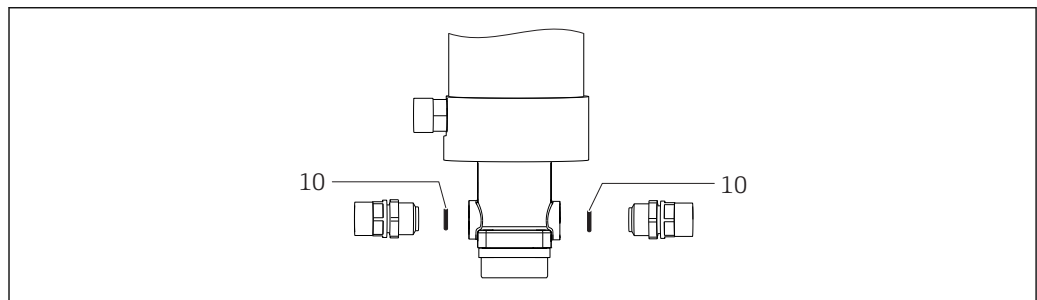

A0030315

#### 35 Replacing seals, Part 3

10 O-rings, rinse connection adapter

3. Remove the O-rings indicated (pos. 10).
4. Apply a thin layer of grease (e.g., Klüber Paraliq GTE 703) to the new O-rings.
5. Insert the O-rings into the corresponding grooves.

### Seal replacement in the support housing

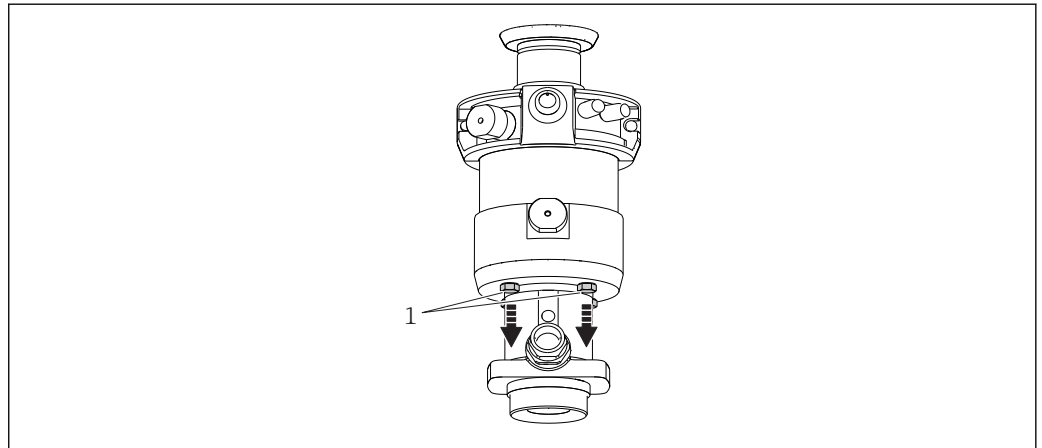

A0030310

#### 36 Replacing seals, Part 4

##### 1 Securing screws AF8

1. Release the four securing screws (pos. 1).

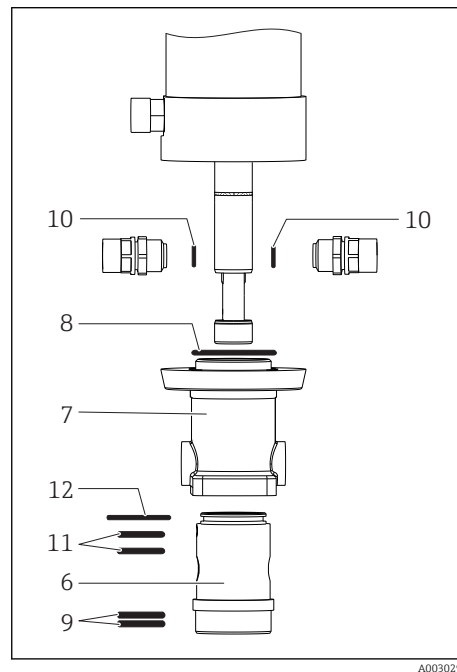

A0030293

#### 37 Replacing all seals

2. Remove the support housing (pos. 7).
3. Pull the service chamber (pos. 6) out of the support housing.
4. Remove the O-rings indicated.
5. Apply a thin layer of grease (e.g., Klüber Paraliq GTE 703) to the new O-rings.
6. Insert the O-rings into the corresponding grooves.

- 6 Service chamber
- 7 Support housing
- 8 O-ring, support housing
- 9 O-rings, bottom of service chamber
- 10 O-rings, rinse connection adapter
- 11 O-rings, top of service chamber
- 12 O-ring, outer service chamber

## Assembly

### Fit support housing and service chamber together

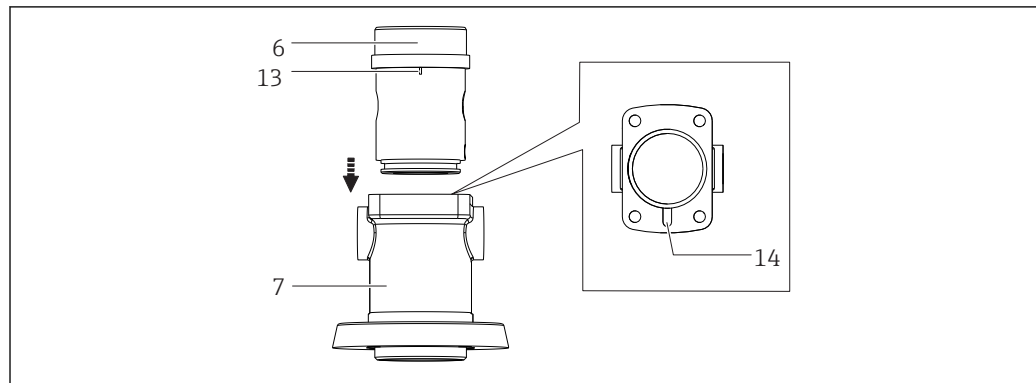

A0030343

#### 38 Assembling the support housing

- 6 Service chamber
- 7 Support housing
- 13 Positioning pin
- 14 Positioning groove

1. Place the support housing (pos. 7) on a level surface.  
↳ The positioning groove (pos. 14) is visible from above.
2. Place the service chamber (pos. 6) on the support housing.
3. Slide the service chamber into the support housing.
4. Place the positioning pin (pos. 13) over the corresponding groove.
5. Push the service chamber into the groove.
6. Mount the process connection on the support housing.
7. Tighten the securing screws with a torque of 4 Nm.

### Tighten the lock nut

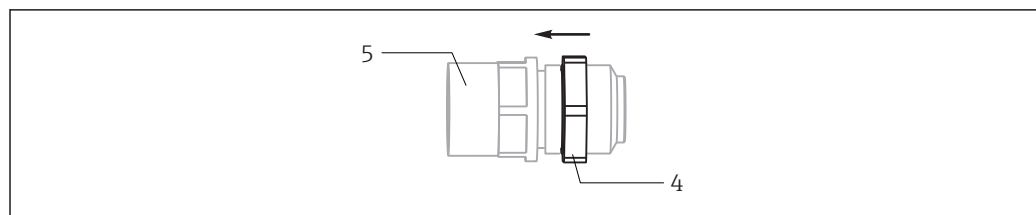

A0030344

#### 39 Assembling the rinse connection

- 4 Lock nut AF19
- 5 Rinse connection adapter AF17

1. Turn the lock nut (pos. 4) on both of the rinse connection adapters (pos. 5) as far as possible in the direction of the arrow.
2. Insert the rinse connection adapters with O-rings into the support housing (open-ended wrench or socket wrench AF 17 mm).
3. Tighten the lock nut (AF 19 mm) in the opposite direction to the arrow.
4. Mount the support housing on the assembly. Pay attention to the positioning pin.
5. Tighten the securing screws with a torque of 4 Nm.

#### Test for leak-tightness

Use the plug to check that the assembly is sealed tightly:

1. Seal the rinse chamber outlet with the plug.

2. Apply pneumatic pressure to the rinse chamber inlet (max. 6 bar absolute pressure).
3. Hold the assembly under water as far as the rinse chamber. In so doing, do not submerge the drive in the water.
  - ↳ The test is successful if no air bubbles appear.

## 8.5.2 Immersion chamber version

### Seal replacement in the process connection

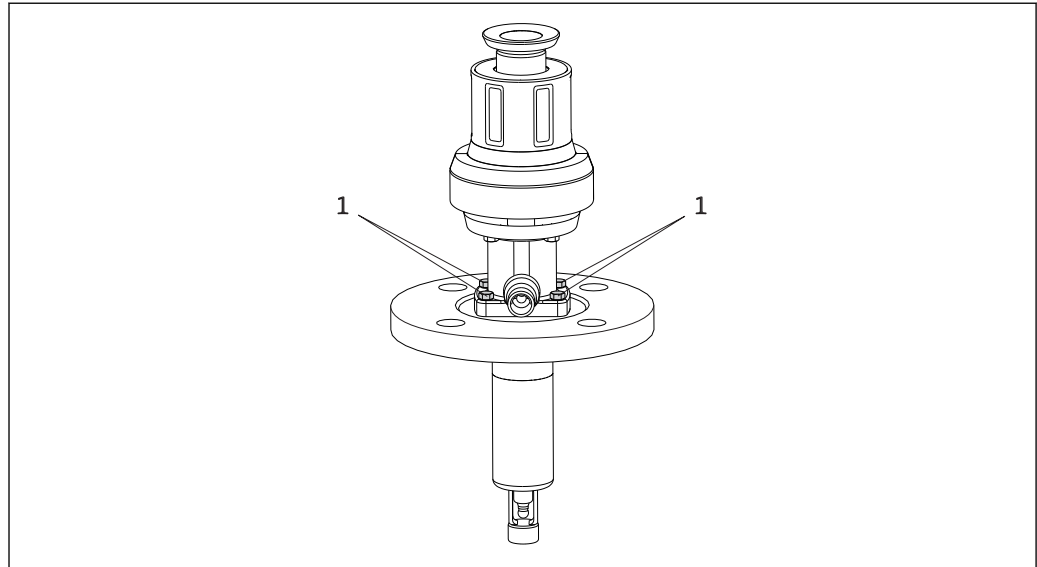

A0030294

40 Replacing seals, Part 1

1. Release the four securing screws (pos. 1).

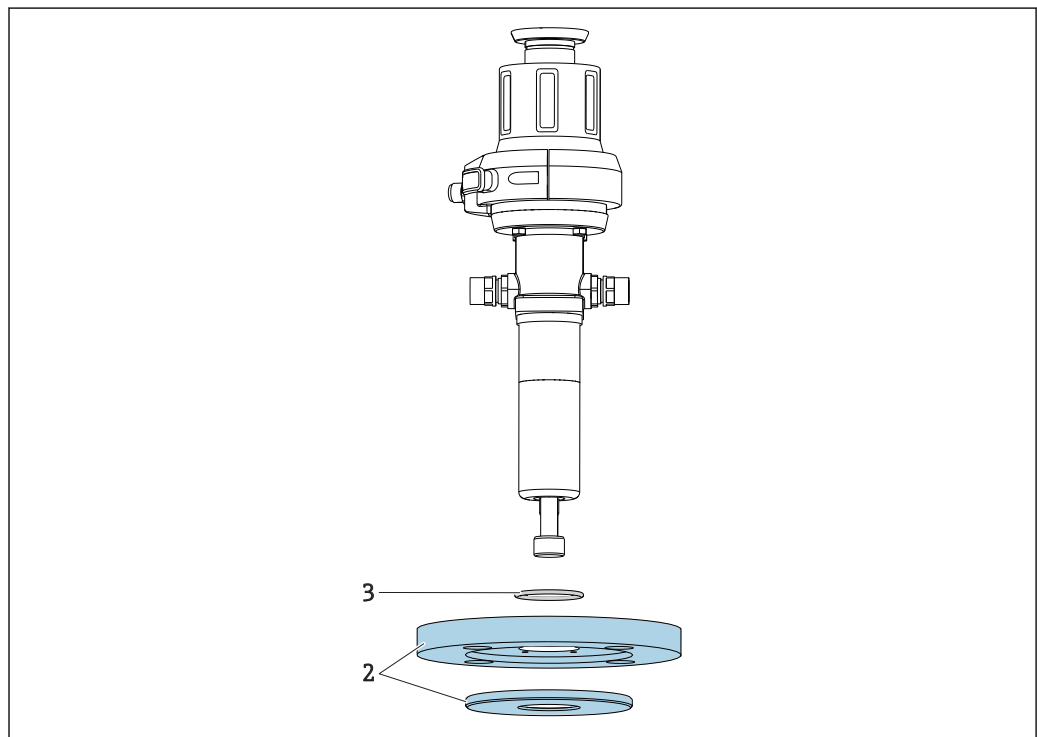

A0030295

41 Replacing seals, Part 2

- 2 Process connection
- 3 O-ring in process connection

2. Remove the service chamber (pos. 3) with the process connection (pos. 2).
3. Remove the O-ring (pos. 3) from the process connection (gasket).
4. Apply a thin layer of grease to the new O-ring (e.g., Klüber Paraliq GTE 703).
5. Insert the O-ring into the process connection.

### Seal replacement in the rinse connection adapter

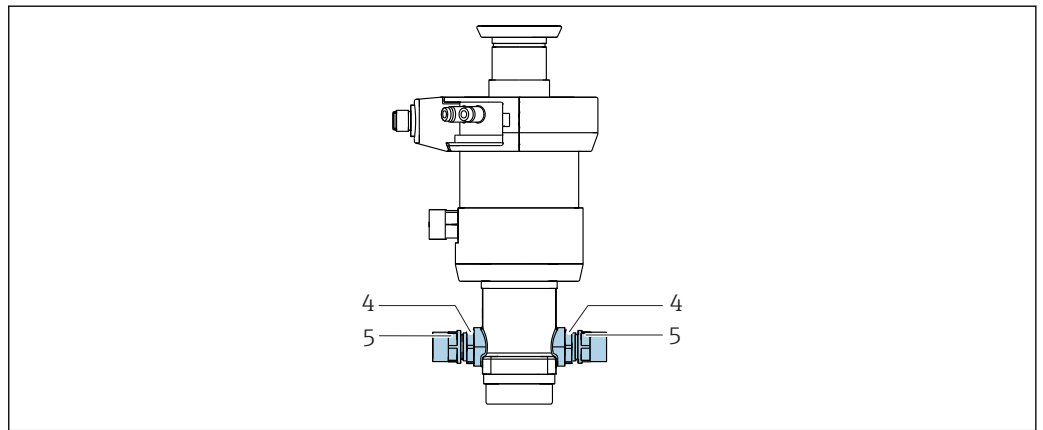

A0030292

#### 42 Replacing seals, Part 3

4 Lock nut AF19

5 Rinse connection adapter AF17

1. Release the lock nuts (pos. 4) using a 19 mm open-ended wrench or socket wrench (in protective cover).
2. Unscrew the two rinse connection adapters (pos. 5).

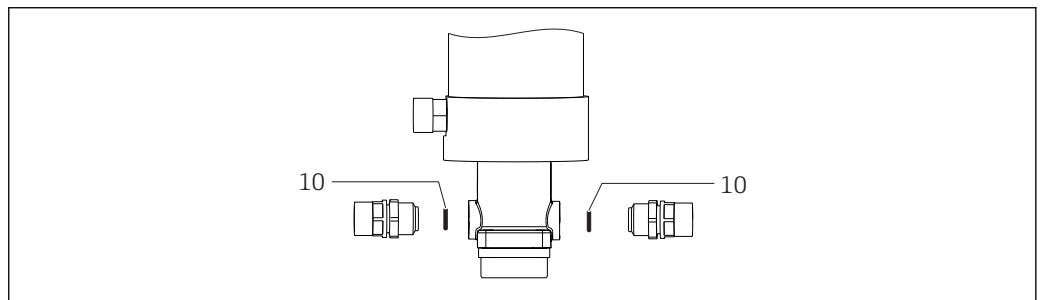

A0030315

#### 43 Replacing seals, Part 3

10 O-rings, rinse connection adapter

3. Remove the O-rings indicated (pos. 10).
4. Apply a thin layer of grease (e.g., Klüber Paraliq GTE 703) to the new O-rings.
5. Insert the O-rings into the corresponding grooves.

### Seal replacement in the immersion chamber

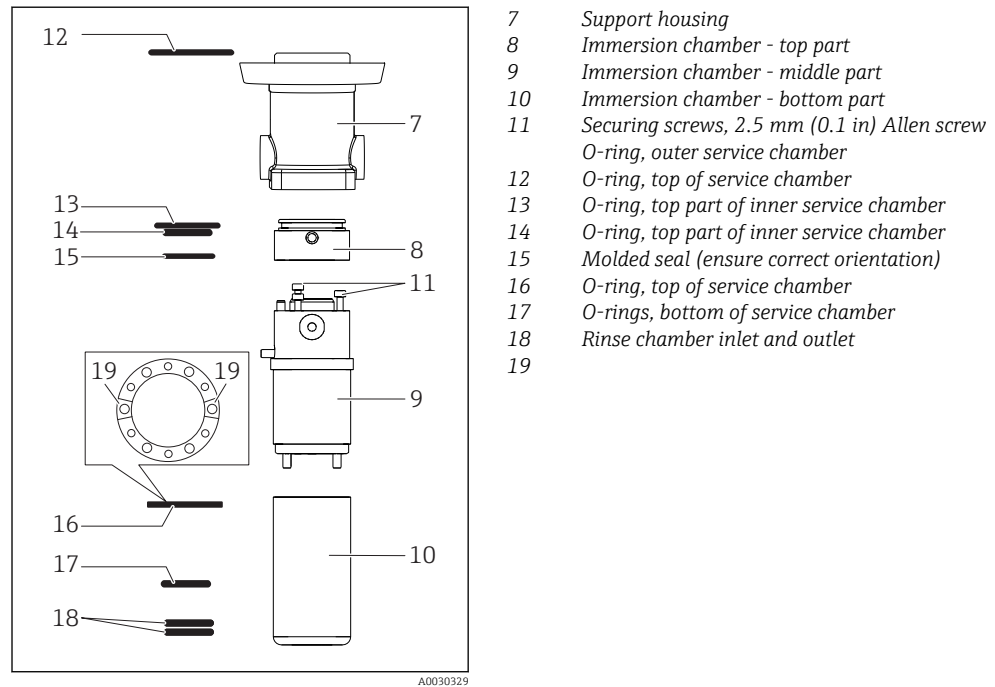

#### 44 Replacing all seals

1. Remove the support housing (pos. 7) with the immersion chamber (pos. 8 - 10).
2. Pull the immersion chamber out of the support housing.
3. Remove the top part of the immersion chamber (pos. 8).
4. Release the three screws (pos. 11).
5. Remove the bottom part of the immersion chamber.
6. Remove the O-rings and the molded seal (pos. 12 to 18).
7. Apply a thin layer of grease (e.g., Klüber Paraliq GTE 703) to the O-rings.
8. Insert the O-rings into the corresponding grooves.
9. Insert the molded seal in such a way that both openings with the stop ridges (pos. 19) are positioned above the rinse chamber inlet and outlet.



### Assembly

In the immersion chamber version, the inlet and outlet of the service chamber are fixed.

- i** When assembling the immersion tube, please ensure that the leakage hole (pos.11), the service chamber outlet (pos. 12) and the immersion chamber (pos. 16) are all in one line.

### Fit the components of the immersion chamber together.

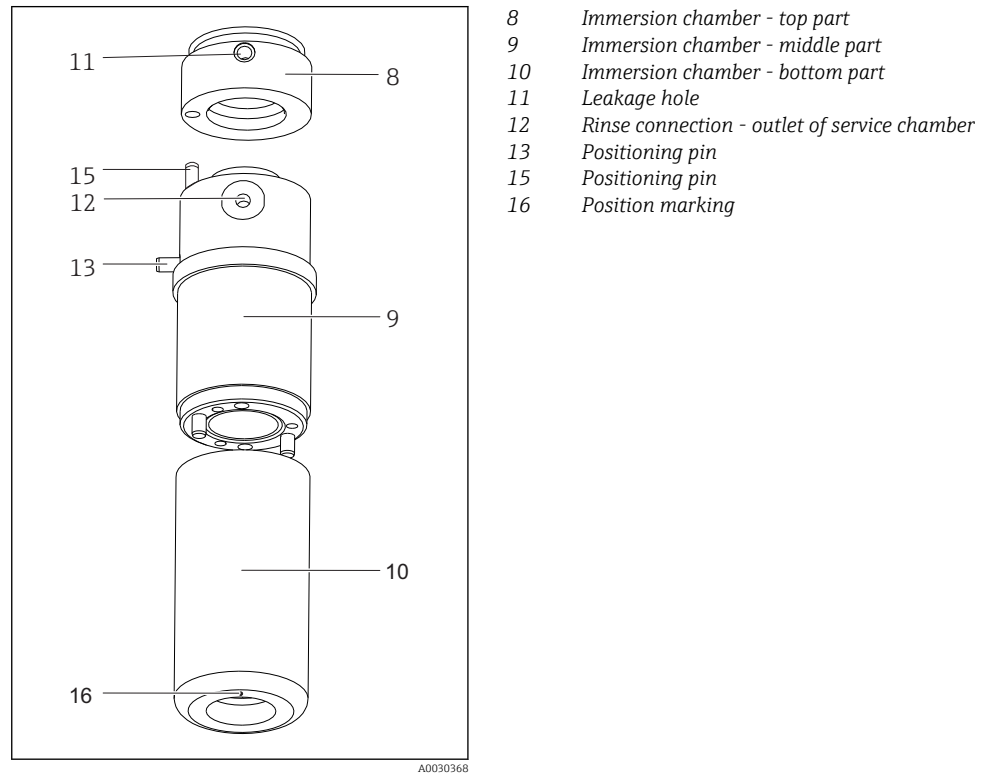

#### **i** 45 Assembling the immersion chamber

1. Fit the bottom part (pos. 10) and middle part (pos. 9) of the immersion chamber together. Ensure correct orientation!
2. Screw both parts securely together using the three securing screws (pos. 11).
3. Attach the top part (pos. 8) of the immersion chamber.

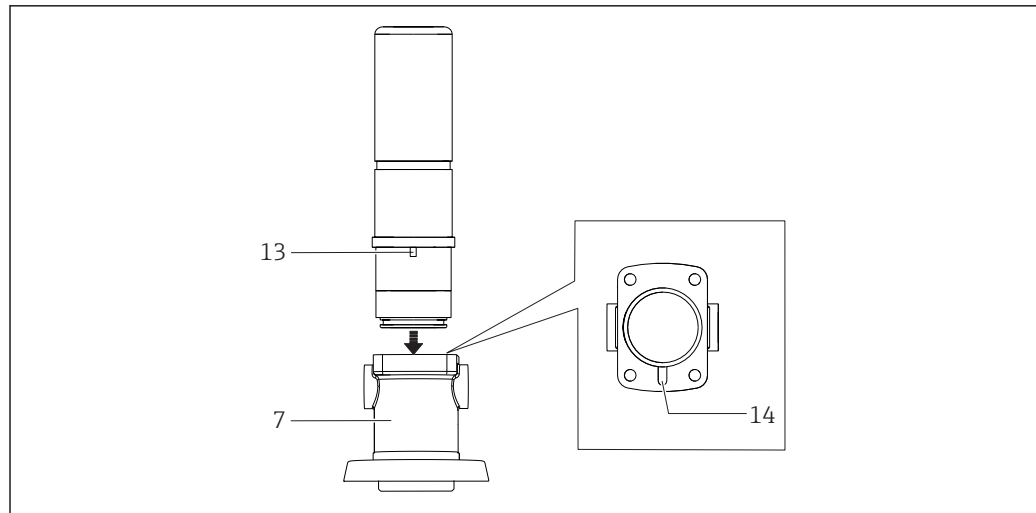

A0030347

**46** *Assembling the support housing and immersion chamber*

- 4 Support housing  
 13 Positioning pin  
 14 Positioning groove

4. Place the support housing (pos. 7) on a level surface.  
 ↳ The positioning groove (pos. 14) is visible from above.
5. Place the immersion chamber on the support housing.
6. Slide the service chamber into the support housing.
7. Place the positioning pin (pos. 13) over the corresponding groove.
8. Push the service chamber into the groove.
9. Mount the process connection on the support housing.
10. Tighten the securing screws with a torque of 4 Nm.

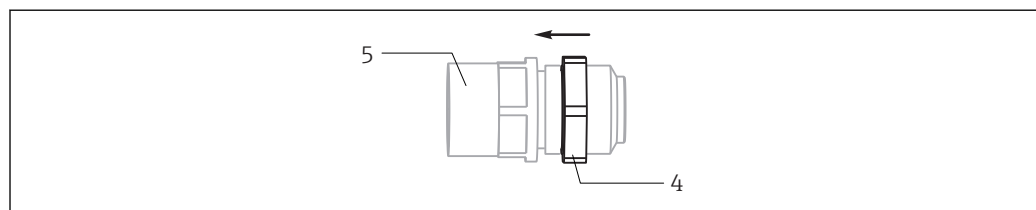

A0030344

**47** *Assembling the rinse connection*

- 4 Lock nut AF19  
 5 Rinse connection adapter AF17

11. Turn the lock nut (pos. 4) on both of the rinse connection adapters (pos. 5) as far as possible in the direction of the arrow.
12. Insert the rinse connection adapters with O-rings into the support housing (open-ended wrench or socket wrench AF 17 mm).
13. Tighten the lock nut (AF 19 mm) in the opposite direction to the arrow.
14. Mount the support housing on the assembly. Pay attention to the positioning pin.
15. Tighten the securing screws with a torque of 4 Nm.

**Test for leak-tightness**

10. Seal the rinse chamber outlet with the plug.
11. Apply pressure to the rinse chamber inlet pneumatically (max. 6 bar absolute pressure)

12. Hold the assembly under water as far as the rinse chamber. In so doing, do not submerge the drive in the water.

The test is successful if no air bubbles appear.

## 9 Repair

### WARNING

#### **Danger resulting from improper repair!**

- ▶ Any damage to the assembly that compromises pressure safety must be repaired only by authorized and qualified personnel.
- ▶ Damage to the drive can be repaired only at the place of manufacture. Repairs cannot be carried out onsite.
- ▶ Following each repair and maintenance task, check the assembly for leaks using appropriate procedures. Following this, the assembly must again comply with the specifications in the technical data.
- ▶ Replace all other damaged components immediately.

### 9.1 Spare parts

For more detailed information on spare parts kits, please refer to the "Spare Part Finding Tool" on the Internet:

[www.endress.com/spareparts\\_consumables](http://www.endress.com/spareparts_consumables)

### 9.2 Return

The product must be returned if repairs or a factory calibration are required, or if the wrong product was ordered or delivered. As an ISO-certified company and also due to legal regulations, Endress+Hauser is obliged to follow certain procedures when handling any returned products that have been in contact with medium.

To ensure the swift, safe and professional return of the device:

- ▶ Refer to the website [www.endress.com/support/return-material](http://www.endress.com/support/return-material) for information on the procedure and conditions for returning devices.

### 9.3 Disposal

The device contains electronic components. The product must be disposed of as electronic waste.

- ▶ Observe the local regulations.

## 10 Accessories

The following are the most important accessories available at the time this documentation was issued.

- For accessories not listed here, please contact your Service or Sales Center.

The following accessories can be ordered via the product structure (see ordering information):

- Weld-in adapter G1¼, straight, 35 mm, 1.4435 (AISI 316 L), safety nozzle
- Weld-in adapter G1¼, angled, 35 mm, 1.4435 (AISI 316 L), safety nozzle

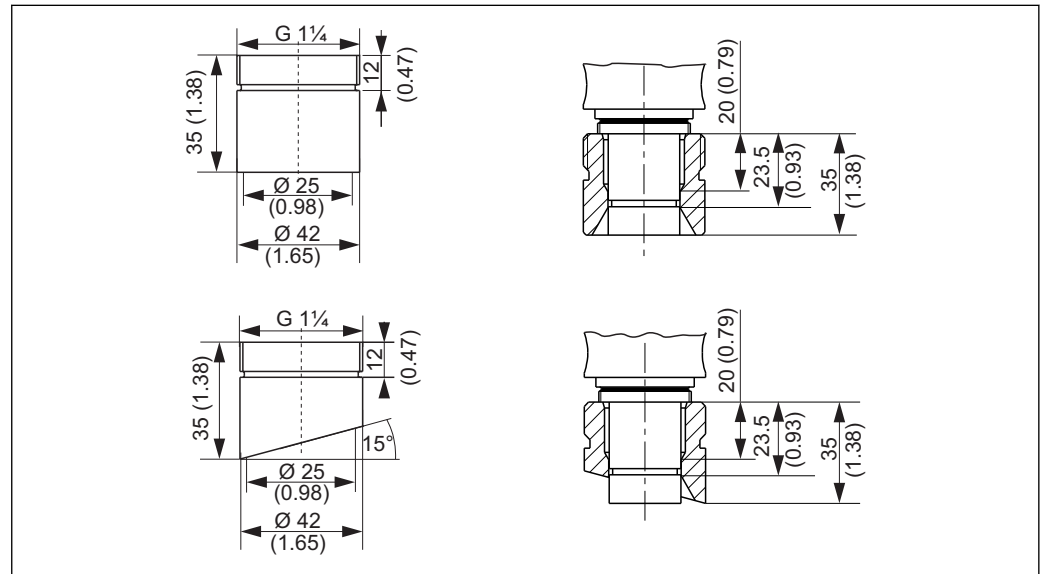

■ 48 Weld-in adapter (safety nozzle), dimensions in mm (in)

- Dummy plug G1¼, 1.4435 (AISI 316 L), FPM - FDA
- Sensor dummy 120 mm, 1.4435 (AISI 316 L), Ra = 0.38 µm
- Sensor dummy 225 mm, 1.4435 (AISI 316 L), Ra = 0.38 µm
- Sensor dummy 360 mm, 1.4435 (AISI 316 L), Ra = 0.38 µm
- Kit, seals for non-wetted parts
- Kit, FKM seals, G1¼, wetted parts
- Kit, FKM seals, immersion chamber version, wetted parts
- Kit, seal, wetted, EPDM
- Kit, seal, wetted, FKM
- Kit, seal, FFKM, basic, wetted
- Cable, plug-in, limit switch, M12, 5 m
- Cable, plug-in, limit switch, M12, 10 m
- Tool in case for installation/removal
- Output interface terminals, version: CPA871-620-R7
  - NAMUR terminals for limit position switches
    - Operation of 8V DC feedback signals on 24V DC devices
    - Suitable for top-hat rail mounting

## 10.1 Installation material for rinse connections

### Filter set CPC310, CVC400

- Water filter (dirt trap) 100 µm, complete, incl. angle bracket
- Order No. 71031661

### Pressure reducer kit

- Complete, incl. manometer and angle bracket
- Order No. 51505755

### Hose connection set G<sup>1</sup>/<sub>4</sub>, DN 12

- 1.4404 (AISI 316L) 2 x
- Order No. 51502808

### Hose connection set G<sup>1</sup>/<sub>4</sub>, DN 12

- PVDF (2 x)
- Order No. 50090491

## 10.2 Cleaning systems

### Air-Trol 500

- Control unit for Cleanfit retractable assemblies
- Order No. 50051994



Technical Information TI00038C/07/EN

### Cleanfit Control CYC25

- Converts electrical signals into pneumatic signals to control pneumatically-operated retractable assemblies or pumps in conjunction with Liquiline CM44x
- Wide range of control options
- Product Configurator on the product page: [www.endress.com/cyc25](http://www.endress.com/cyc25)



Technical Information TI01231C

### Liquiline Control CDC90

- Fully automatic cleaning and calibration system for pH and ORP measuring points in all industries
- Cleaned, validated, calibrated and adjusted
- Product Configurator on the product page: [www.endress.com/cdc90](http://www.endress.com/cdc90)



Technical Information TI01340C

## 10.3 Flow vessel

### Flow vessel

- Flange DN 25 ISO 1092-2 PN16
- Material: stainless steel 1.4404 (AISI 316 L)

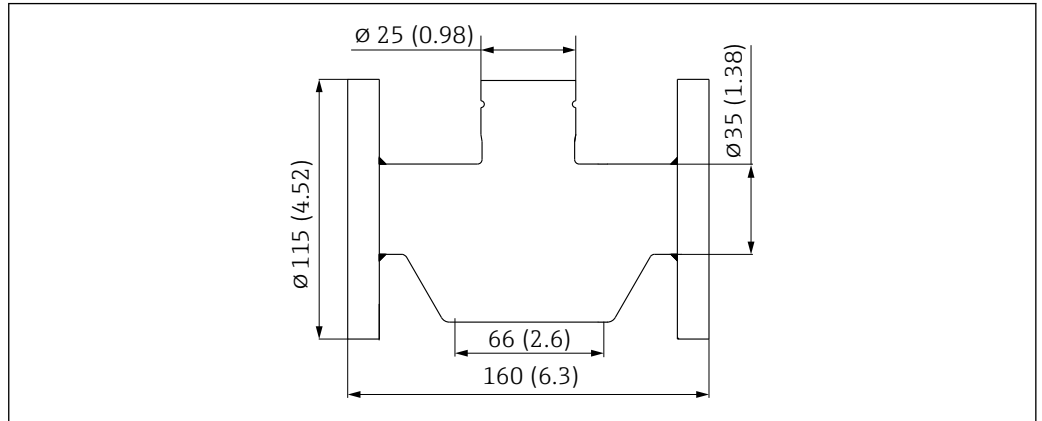

A0039147

49 Dimensions in mm (in)

 Dummy plug available for maintenance purposes

## 10.4 Sensors

### 10.4.1 pH sensors

#### Orbisint CPS11D / CPS11

- pH sensor for process technology
- Optional SIL version for connecting to SIL transmitter
- With dirt-repellent PTFE diaphragm
- Product Configurator on the product page: [www.endress.com/cps11d](http://www.endress.com/cps11d) or [www.endress.com/cps11](http://www.endress.com/cps11)

 Technical Information TI00028C

#### Memosens CPS31D

- pH electrode with gel-filled reference system with ceramic diaphragm
- Product Configurator on the product page: [www.endress.com/cps31d](http://www.endress.com/cps31d)

 Technical Information TI00030C

#### Ceraliquid CPS41D / CPS41

- pH electrode with ceramic junction and KCl liquid electrolyte
- Product Configurator on the product page: [www.endress.com/cps41d](http://www.endress.com/cps41d) or [www.endress.com/cps41](http://www.endress.com/cps41)

 Technical Information TI00079C

#### Ceragel CPS71D / CPS71

- pH electrode with reference system including ion trap
- Product Configurator on the product page: [www.endress.com/cps71d](http://www.endress.com/cps71d) or [www.endress.com/cps71](http://www.endress.com/cps71)

 Technical Information TI00245C

#### Orbipore CPS91D / CPS91

- pH electrode with open aperture for media with high dirt load
- Product Configurator on the product page: [www.endress.com/cps91d](http://www.endress.com/cps91d) or [www.endress.com/cps91](http://www.endress.com/cps91)

 Technical Information TI00375C

### 10.4.2 ORP sensors

#### Orbisint CPS12D / CPS12

- ORP sensor for process technology
- Product Configurator on the product page: [www.endress.com/cps12d](http://www.endress.com/cps12d) or [www.endress.com/cps12](http://www.endress.com/cps12)

 Technical Information TI00367C

#### Ceraliquid CPS42D / CPS42

- ORP electrode with ceramic junction and KCl liquid electrolyte
- Product Configurator on the product page: [www.endress.com/cps42d](http://www.endress.com/cps42d) or [www.endress.com/cps42](http://www.endress.com/cps42)

 Technical Information TI00373C



**Ceragel CPS72D / CPS72**

- ORP electrode with reference system including ion trap
- Product Configurator on the product page: [www.endress.com/cps72d](http://www.endress.com/cps72d) or [www.endress.com/cps72](http://www.endress.com/cps72)

 Technical Information TI00374C

**10.4.3 pH ISFET sensors****Tophit CPS441D / CPS441**

- Sterilizable ISFET sensor for low-conductivity media
- Liquid KCl electrolyte
- Product Configurator on the product page: [www.endress.com/cps441d](http://www.endress.com/cps441d) or [www.endress.com/cps441](http://www.endress.com/cps441)

 Technical Information TI00352C

**Tophit CPS471D / CPS471**

- Sterilizable and autoclavable ISFET sensor for food and pharmaceuticals, process engineering
- Water treatment and biotechnology
- Product Configurator on the product page: [www.endress.com/cps471d](http://www.endress.com/cps471d) or [www.endress.com/cps471](http://www.endress.com/cps471)

 Technical Information TI00283C

**Tophit CPS491D / CPS491**

- ISFET sensor with open aperture for media with high dirt load
- Product Configurator on the product page: [www.endress.com/cps491d](http://www.endress.com/cps491d) or [www.endress.com/cps491](http://www.endress.com/cps491)

 Technical Information TI00377C

**10.4.4 pH and ORP combined sensors****Memosens CPS16D**

- Combined pH/ORP sensor for process technology
- With dirt-repellent PTFE diaphragm
- With Memosens technology
- Product Configurator on the product page: [www.endress.com/cps16D](http://www.endress.com/cps16D)

 Technical Information TI00503C

 The 120 mm version in the CPS16D is not suitable.

**Memosens CPS76D**

- Combined pH/ORP sensor for process technology
- Hygienic and sterile applications
- With Memosens technology
- Product Configurator on the product page: [www.endress.com/cps76d](http://www.endress.com/cps76d)

 Technical Information TI00506C

**Memosens CPS96D**

- Combined pH/ORP sensor for chemical processes
- With poison-resistant reference with ion trap
- With Memosens technology
- Product Configurator on the product page: [www.endress.com/cps96d](http://www.endress.com/cps96d)

 Technical Information TI00507C

### 10.4.5 Conductivity sensors

#### **Memosens CLS82D**

- Four-electrode sensor
- With Memosens technology
- Product Configurator on the product page: [www.endress.com/cls82d](http://www.endress.com/cls82d)



Technical Information TI01188C

### 10.4.6 Oxygen sensors

#### **Oxymax COS22D / COS22**

- Sterilizable sensor for dissolved oxygen
- With Memosens technology or as an analog sensor
- Product Configurator on the product page: [www.endress.com/cos22d](http://www.endress.com/cos22d) or [www.endress.com/cos22](http://www.endress.com/cos22)



Technical Information TI00446C

### 10.5 Absorption sensor

#### **OUSBT66**

- NIR absorption sensor for measuring cell growth and biomass
- Sensor version suitable for pharmaceutical industry
- Product Configurator on the product page: [www.endress.com/ousbt66](http://www.endress.com/ousbt66)



Technical Information TI00469C

## 11 Technical data

### 11.1 Environment

---

Ambient temperature -10 to +70 °C (+10 to +160 °F)

---

Storage temperature -10 to +70 °C (+10 to +160 °F)

### 11.2 Process

---

Process temperature -10 to +140 °C (14 to 284 °F) for all materials except PVDF and conductive PVDF  
-10 to +100 / 90 °C (14 to 212 / 194 °F) for PVDF and conductive PVDF materials

---

Process pressure for pneumatic drive	Materials: 1.4404, Alloy C22, PEEK	
	Basic and immersion chamber version:	16 bar (232 psi) up to 140 °C (284 °F)
	Materials: PVDF, conductive PVDF	
	Basic version:	16 bar (232 psi) up to 100 °C (212 °F)
	Immersion chamber version:	4 bar (58 psi) to 90 °C (194 °F)

 The service life of the seals is reduced if process temperatures are constantly high or if SIP is used. The other process conditions may also reduce the service life of the seals.

 Depending on the version, the process pressure must be reduced to insert/retract the assembly.

---

Process pressure for manual drive	Materials: 1.4404, Alloy C22, PEEK	
	Basic and immersion chamber version:	8 bar (116 psi) up to 140 °C (284 °F)
	Materials: PVDF, conductive PVDF	
	Basic version:	8 bar (116 psi) up to 100 °C (212 °F)
	Immersion chamber version:	4 bar (58 psi) to 90 °C (194 °F)

 The service life of the seals is reduced if process temperatures are constantly high or if SIP is used. The other process conditions may also reduce the service life of the seals.

Pressure temperature ratings

**Manual drive, assembly insertion/retraction up to 8 bar**

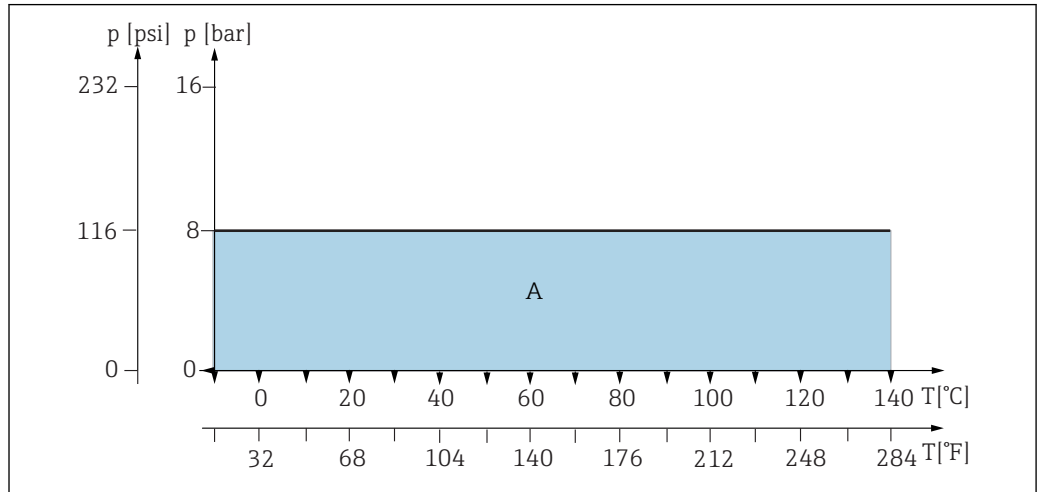

A0039156

50 Pressure temperature ratings for basic and immersion chamber version for materials 1.4404, Alloy C22 and PEEK

A Basic and immersion chamber version

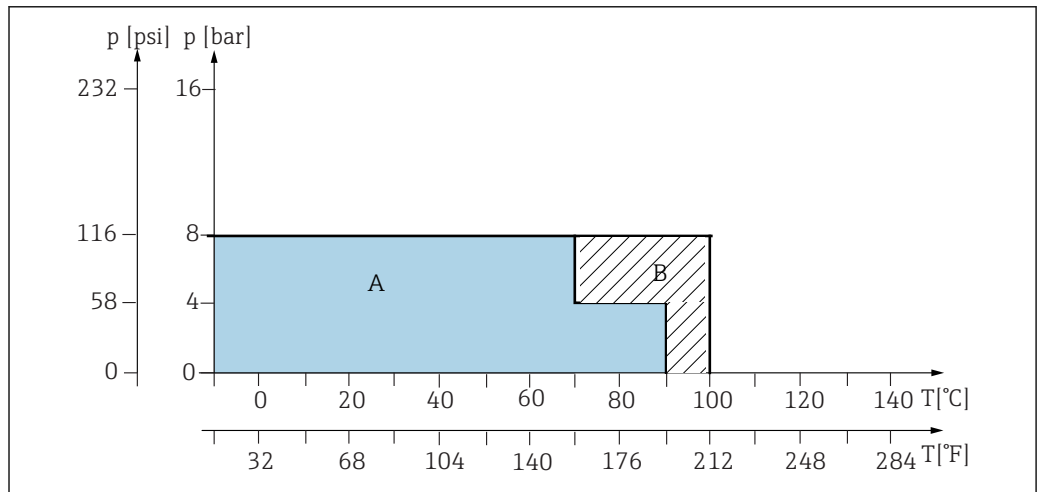

A0039155

51 Pressure temperature ratings for basic version for materials PVDF and conductive PVDF

A Immersion chamber version

B Basic version

**Pneumatic drive, assembly insertion/retraction up to 8 bar (static pressure resistance up to 16 bar)**

**NOTICE**

The process seal can be damaged if pressure is too high during insertion/retraction. Medium escaping from the assembly

- ▶ Assembly insertion/retraction at 8 bar.

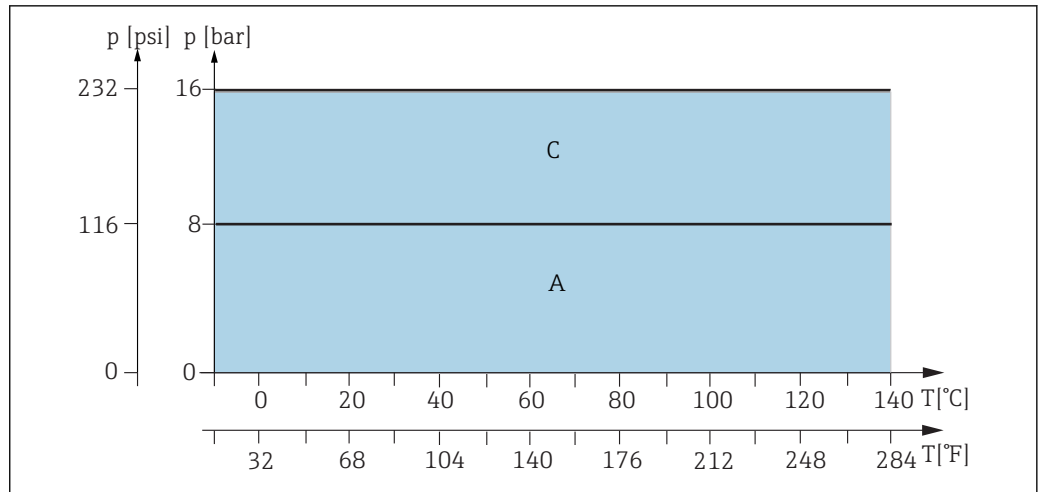

A0039268

52 Pressure temperature ratings for basic and immersion chamber version for materials 1.4404, Alloy C22 and PEEK (CPA871-++G/H+++++)

- A Basic and immersion chamber version
- C Static range, assembly insertion/retraction not permitted

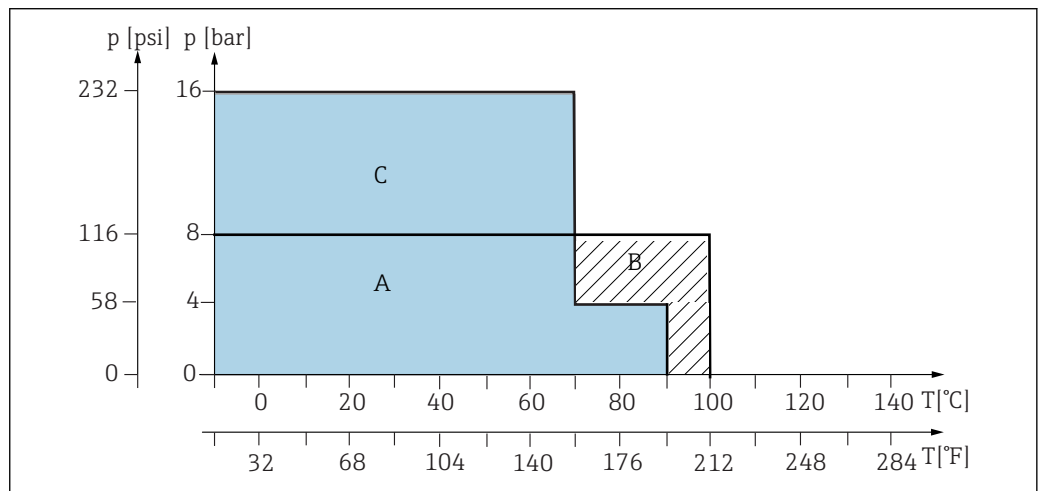

A0039267

53 Pressure temperature ratings for basic version for materials PVDF and conductive PVDF (CPA871-++G/H+++++)

- A Immersion chamber version
- B Basic version
- C Static range, assembly insertion/retraction not permitted

**Pneumatic drive, assembly insertion/retraction up to 16 bar**

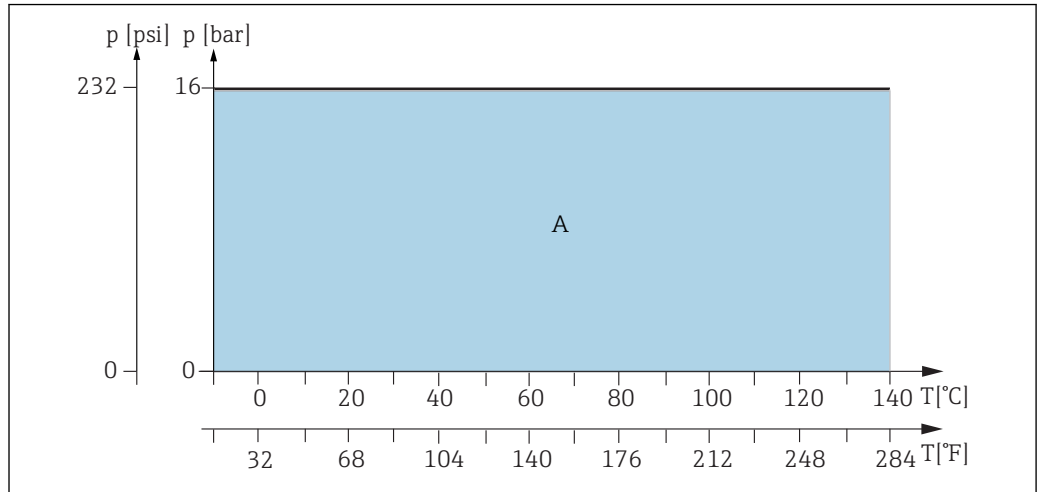

A0039157

54 Pressure temperature ratings for basic and immersion chamber version for materials 1.4404, Alloy C22 and PEEK (CPA871-++E/F+++++)

A Basic and immersion chamber version

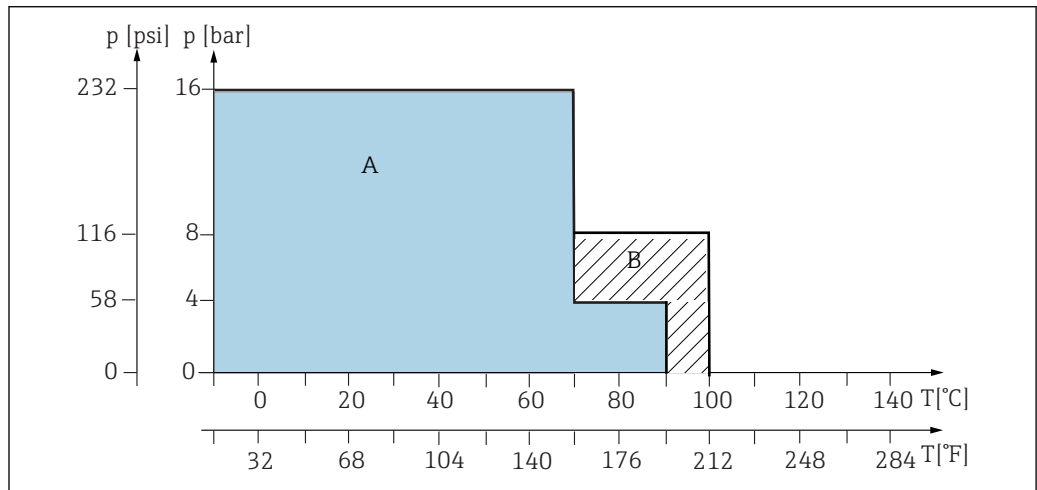

A0039162

55 Pressure temperature ratings for basic version for materials PVDF and conductive PVDF (CPA871-++E/F+++++)

A Immersion chamber version

B Basic version

## 11.3 Mechanical construction

Design, dimensions → Section "Installation"

Rinse chamber volume	Volume cm <sup>3</sup> (in <sup>3</sup> )(max.)	Volume cm <sup>3</sup> (in <sup>3</sup> )(min.)
Single chamber	12.02 (0.73)	2.81 (0.17)
Immersion chamber, short	15.75 (0.96)	6.73 (0.41)
Immersion chamber, long	17.14 (1.05)	8.12 (0.5)

Weight Depends on version:  
 Pneumatic drive: 3.8 to 6 kg (8.4 to 13.2 lbs) depending on version  
 Manual drive: 3 to 4.5 kg (6.6 to 9.9 lbs) depending on version

Materials	<b>In contact with medium</b>	
	Seals:	EPDM/FPM (Viton)/FFKM
	Immersion tube, process connection, service chamber:	Stainless steel 1.4404 (AISI 316L) Ra < 0.76/PEEK/Alloy C22 Ra <0.76/PVDF/conductive PVDF
	Rinse connections:	Stainless steel 1.4404 (AISI 316L) and Alloy C22

<b>Not in contact with medium</b>	
Manual drive:	Stainless steel 1.4301 (AISI 304) or 1.4404 (AISI 316L), plastics PPS CF15, PBT, PP
Pneumatic drive:	Stainless steel 1.4301 (AISI 304) or 1.4404 (AISI 316L), plastics PBT, PP

Sensors	Short version		
		Gel sensors, ISFET	120 mm
		Gel sensors, ISFET	225 mm
		KCl sensors	225 mm
	Long version		
		Gel sensors, ISFET	225 mm
		Gel sensors, ISFET	360 mm
	Immersion chamber version		
		Gel sensors, ISFET	225 mm
		KCl sensors	360 mm

Limit position switches	Switching element function:	NAMUR NC contact (inductive)
	Switching distance:	1.5 mm (0.06 ")
	Nominal voltage:	8 V
	Switching frequency:	0 to 5000 Hz
	Housing material:	Stainless steel
	Output interface terminals	NAMUR
	Limit position switch (inductive sensors)	Pepperl+Fuchs NJ1.5-6.5-15-N-Y180094

## Index

### A

Accessories .....	53
Approvals .....	11

### C

Certificates .....	11
Cleaning .....	38
Cleaning agent .....	39
Connection	
Pneumatics .....	21

### D

Designated use .....	5
Dimensions .....	13
Disposal .....	52

### F

Failure of compressed air supply .....	35
--	----

### I

Immersion depths .....	17
Incoming acceptance .....	9
Installation .....	12, 18
Installation conditions .....	12
Installing the sensor .....	26

### L

Limit position switches .....	24
-------------------------------	----

### M

Maintenance .....	36
Maintenance intervals .....	36
Manual operation .....	34
Measuring system .....	18
Mounting conditions .....	12

### N

Nameplate .....	10
-----------------	----

### O

O-rings .....	40
Operation .....	33
Manual .....	34
Pneumatic .....	34

### P

Pneumatic connection .....	21
Pneumatic operation .....	34
Post-installation check .....	31
Product identification .....	9

### R

Repair .....	52
Return .....	52
Rinse connections .....	23

### S

Safety instructions .....	5
Scope of delivery .....	9
Seals .....	40
Spare parts .....	52
Symbols .....	4

### T

Technical data .....	59
----------------------	----

### U

Use .....	5
-----------	---

### W

Warnings .....	4
----------------	---











71439183

[www.addresses.endress.com](http://www.addresses.endress.com)

---