

# Operating Instructions

## Memosens COS81E

Hygienic, optical sensor with Memosens 2.0 technology for the measurement of oxygen







## Table of contents







<b>1</b>	<b>About this document</b> .....	<b>4</b>	10.2	Spare parts and consumables .....	29
1.1	Warnings .....	4	10.3	Return .....	29
1.2	Symbols used .....	4	10.4	Spare parts .....	29
1.3	Supplementary documentation .....	5	10.5	Checking the measurement function .....	33
<b>2</b>	<b>Basic safety instructions</b> .....	<b>6</b>	10.6	Disposal .....	33
2.1	Requirements for personnel .....	6	<b>11</b>	<b>Accessories</b> .....	<b>34</b>
2.2	Designated use .....	6	11.1	Device-specific accessories .....	34
2.3	Workplace safety .....	6	<b>12</b>	<b>Technical data</b> .....	<b>37</b>
2.4	Operational safety .....	7	12.1	Input .....	37
2.5	Product safety .....	7	12.2	Performance characteristics .....	37
<b>3</b>	<b>Product description</b> .....	<b>8</b>	12.3	Environment .....	37
3.1	Measuring principle .....	8	12.4	Process .....	38
3.2	Product design .....	9	12.5	Mechanical construction .....	38
3.3	Stabilization time .....	10			
3.4	Memosens technology .....	10			
<b>4</b>	<b>Incoming acceptance and product identification</b> .....	<b>11</b>			
4.1	Incoming acceptance .....	11			
4.2	Product identification .....	11			
4.3	Scope of delivery .....	12			
4.4	Certificates and approvals .....	12			
<b>5</b>	<b>Installation</b> .....	<b>15</b>			
5.1	Installation conditions .....	15			
5.2	Mounting the sensor .....	16			
5.3	Installation examples .....	17			
5.4	Post-installation check .....	20			
<b>6</b>	<b>Electrical connection</b> .....	<b>21</b>			
6.1	Connecting the sensor .....	21			
6.2	Ensuring the degree of protection .....	21			
6.3	Post-connection check .....	21			
<b>7</b>	<b>Commissioning</b> .....	<b>22</b>			
7.1	Function check .....	22			
7.2	Calibration and adjustment .....	22			
<b>8</b>	<b>Diagnostics and troubleshooting</b> ...	<b>26</b>			
8.1	General troubleshooting .....	26			
<b>9</b>	<b>Maintenance</b> .....	<b>27</b>			
9.1	Maintenance schedule .....	27			
9.2	Maintenance tasks .....	27			
<b>10</b>	<b>Repair</b> .....	<b>29</b>			
10.1	General notes .....	29			

# 1 About this document



## 1.1 Warnings

Structure of information	Meaning
 <b>DANGER</b> <b>Causes (/consequences)</b> If necessary, Consequences of non-compliance (if applicable) <ul style="list-style-type: none"> <li>▶ Corrective action</li> </ul>	This symbol alerts you to a dangerous situation. Failure to avoid the dangerous situation <b>will</b> result in a fatal or serious injury.
 <b>WARNING</b> <b>Causes (/consequences)</b> If necessary, Consequences of non-compliance (if applicable) <ul style="list-style-type: none"> <li>▶ Corrective action</li> </ul>	This symbol alerts you to a dangerous situation. Failure to avoid the dangerous situation <b>can</b> result in a fatal or serious injury.
 <b>CAUTION</b> <b>Causes (/consequences)</b> If necessary, Consequences of non-compliance (if applicable) <ul style="list-style-type: none"> <li>▶ Corrective action</li> </ul>	This symbol alerts you to a dangerous situation. Failure to avoid this situation can result in minor or more serious injuries.
<b>NOTICE</b> <b>Cause/situation</b> If necessary, Consequences of non-compliance (if applicable) <ul style="list-style-type: none"> <li>▶ Action/note</li> </ul>	This symbol alerts you to situations which may result in damage to property.

## 1.2 Symbols used

Symbol	Meaning
	Additional information, tips
	Permitted or recommended
	Not permitted or not recommended
	Reference to device documentation
	Reference to page
	Reference to graphic
	Result of a step

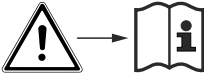
### 1.2.1 Symbols on the device

Symbol	Meaning
	Reference to device documentation
	Do not dispose of products bearing this marking as unsorted municipal waste. Instead, return them to the manufacturer for disposal under the applicable conditions.

### 1.3 Supplementary documentation

The following manuals which complement these Operating Instructions can be found on the product pages on the Internet:

- Technical Information for the relevant sensor
- Operating Instructions for the transmitter used
- Operating Instructions for the cable used

In addition to these Operating Instructions, an XA with "Safety instructions for electrical apparatus in the hazardous area" is also included with sensors for use in the hazardous area.

- ▶ Please follow instructions on use in the hazardous area carefully.

**Safety instructions for electrical equipment in hazardous areas, Memosens 2.0 optical oxygen:**

- ATEX and IECEX: **XA02238C**
- INMETRO: **XA02475C**
- NEPSI: **XA02476C**
- JPN Ex: **XA02485C**
- CSA C/US: **XA02520C**

## 2 Basic safety instructions

### 2.1 Requirements for personnel

- Installation, commissioning, operation and maintenance of the measuring system may be carried out only by specially trained technical personnel.
- The technical personnel must be authorized by the plant operator to carry out the specified activities.
- The electrical connection may be performed only by an electrical technician.
- The technical personnel must have read and understood these Operating Instructions and must follow the instructions contained therein.
- Faults at the measuring point may only be rectified by authorized and specially trained personnel.

 Repairs not described in the Operating Instructions provided must be carried out only directly at the manufacturer's site or by the service organization.

### 2.2 Designated use

The sensor is designed for continuous measurement of dissolved oxygen in water and aqueous solutions, and also for continuous measurement of oxygen in gases.

The sensor is particularly suitable for:

- Monitoring inertization equipment in the food industry
- Monitoring, measuring and regulating the oxygen content in chemical processes
- Monitoring of fermentation processes

#### NOTICE

##### Halogen-containing solvents, ketones and toluene

Halogen-containing solvents (dichloromethane, chloroform), ketones (e.g. acetone, pentanone) and toluene have a cross-sensitive effect and result in decreased measured values or, at worst, in the complete failure of the sensor!

- ▶ Use the sensor only in media that are free from halogens, ketones and toluene.

For non-contact digital data transmission, the sensor must be connected to the digital input of the transmitter for Memosens sensors using the CYK10 measuring cable.

Use of the device for any purpose other than that described, poses a threat to the safety of people and of the entire measuring system and is therefore not permitted.

The manufacturer is not liable for damage caused by improper or non-designated use.

### 2.3 Workplace safety

As the user, you are responsible for complying with the following safety conditions:

- Installation guidelines
- Local standards and regulations
- Regulations for explosion protection

##### Electromagnetic compatibility

- The product has been tested for electromagnetic compatibility in accordance with the applicable international standards for industrial applications.
- The electromagnetic compatibility indicated applies only to a product that has been connected in accordance with these Operating Instructions.

## 2.4 Operational safety

### Before commissioning the entire measuring point:

1. Verify that all connections are correct.
2. Ensure that electrical cables and hose connections are undamaged.
3. Do not operate damaged products, and protect them against unintentional operation.
4. Label damaged products as defective.

### During operation:

- ▶ If faults cannot be rectified:  
products must be taken out of service and protected against unintentional operation.

## 2.5 Product safety

### 2.5.1 State-of-the-art technology

The product is designed to meet state-of-the-art safety requirements, has been tested, and left the factory in a condition in which it is safe to operate. The relevant regulations and international standards have been observed.

## 3 Product description

### 3.1 Measuring principle

#### 3.1.1 Optical measuring principle

##### Sensor structure

Oxygen-sensitive molecules (markers) are integrated into the optically active layer (luminescence layer).

The luminescence layer, an optical insulating layer and a cover layer are applied on top of one another on the carrier. The cover layer is in direct contact with the medium.

The sensor optics are directed at the rear of the carrier and therefore at the luminescence layer.

##### Measurement process (principle of luminescence quenching)

If the sensor is immersed in the medium, an equilibrium is very quickly established between the oxygen partial pressure in both the medium and the luminescence layer.

1. The sensor optics send orange light pulses to the luminescence layer.
2. The markers "respond" (luminesce) with dark-red light pulses.
  - ↳ The decay time and intensity of the response signals are directly dependent on the oxygen contents and oxygen partial pressure.

If the medium is free from oxygen, the response signals are long and very intense.

If the medium is free from oxygen, the decay time is long and the signal is very intense.

Any oxygen molecules present mask the marker molecules. As a result, the decay time is shorter and the signals are less intense.

##### Measurement result

- ▶ The sensor calculates the measurement result on the basis of the signal intensity and decay time using the Stern-Volmer equation.

The air pressure can be either set statically or entered via an additional sensor. The medium temperature is automatically recorded in the sensor. Both values are taken into consideration in the calculation of the oxygen concentration.

The sensor provides measured values for temperature and partial pressure as well as a raw measured value. This value corresponds to the luminescence decay time and is approx. 14  $\mu$ s in air and approx. 56  $\mu$ s in oxygen-free media.

##### For optimum measurement results

1. During calibration, enter the current air pressure at the transmitter.
2. If the calibration is not performed at **Air 100% rh**:  
Enter the current humidity.
3. In the case of saline media:  
Enter the salinity.



- 4. For measurements in the units %Vol or %SAT:  
Also enter the current operating pressure in the measuring mode.



- Observe the documentation of the transmitter used:
  - Operating Instructions for Memosens: BA01245C  
For all transmitters, analyzers and samplers in the Liquiline CM44x/P/R, Liquiline System CA80XX and Lquistation CSFxx product families
  - Operating Instructions for Liquiline CM42, BA00381C and BA00382C
  - Operating Instructions for Liquiline Mobile CML18: BA02002C
  - Operating Instructions for Liquiline Compact CM82: BA01845C
  - Operating Instructions for Liquiline Compact CM72: BA01797C

### 3.2 Product design

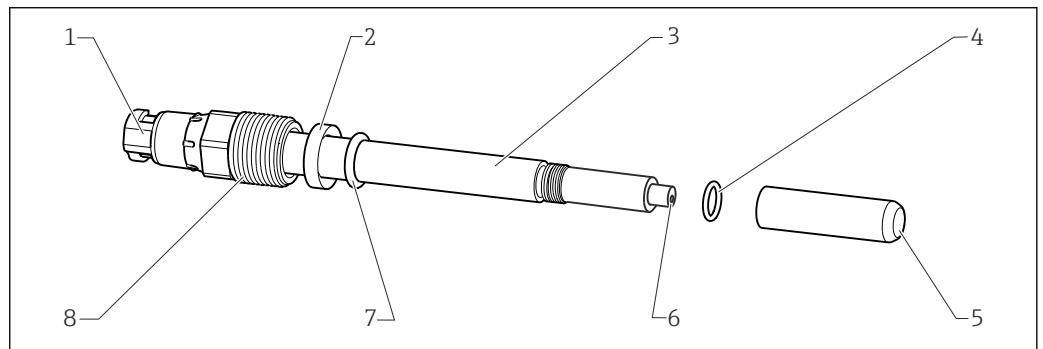

1	<i>Memosens COS81E</i>	5	<i>Spot cap</i>
1	<i>Memosens plug-in head with optics assembly</i>	6	<i>Optical waveguide with temperature sensor</i>
2	<i>Thrust collar</i>	7	<i>Process seal 10.77 x 2.62 mm</i>
3	<i>Sensor shaft</i>	8	<i>Process connection Pg 13.5</i>
4	<i>O-ring sensor shaft</i>		



The suitability of the selected materials for use in the process must be assessed during the product configuration.

Process conditions that go beyond the resistance range of the materials may shorten the operating life of the materials and make maintenance necessary.

#### 3.2.1 Spot cap

The oxygen dissolved in the medium is diffused to the luminescence layer of the spot cap. A suitable flow is not required, as no oxygen is consumed during measurement. However, flow improves the speed at which the measuring system reacts and ensures a more representative measured value compared to a measurement in a static medium.

The spot is permeable for dissolved gases only. Other substances dissolved in the liquid phase, such as ionic substances, will not penetrate through the membrane. Therefore, medium conductivity has no impact on the measuring signal.

The sensor's spot cap can have either a c-shaped or u-shaped design.

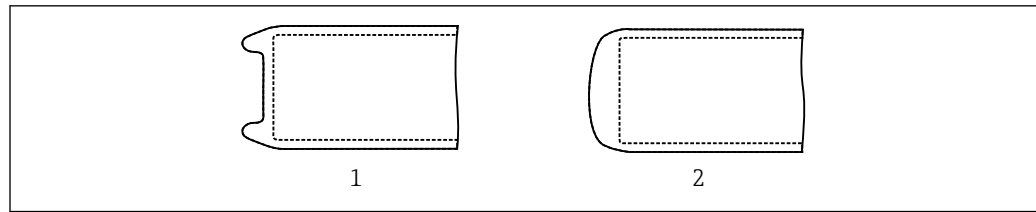

2 Design of spot cap

1 u-shaped

2 c-shaped

A0034733

### 3.3 Stabilization time

The measuring method used by the sensor is temperature-dependent. For this reason, the temperature of the sensor must be adapted to the medium temperature during commissioning. You obtain reliable measured values once a stable temperature value is reached.

The temperature usually adapts very quickly in aqueous media. Temperature adaptation can take several minutes in gaseous media.

### 3.4 Memosens technology

Sensors with Memosens protocol have an integrated electronics unit that stores calibration data and other information. Once the sensor has been connected, the sensor data are transferred automatically to the transmitter and used to calculate the measured value and for Heartbeat functions.

- ▶ Call up the sensor data via the corresponding DIAG menu.

Digital sensors can store measuring system data in the sensor. These include the following:

- Manufacturer data
- Serial number
- Order code
- Date of manufacture
- Digital sensor label
- Calibration data of the last eight calibrations including factory calibration with calibration date and calibration values
- Serial number of the transmitter used to perform the last calibration
- Possibility to reset to factory calibration
- In the case of sensors with replaceable measuring elements, the number of calibrations per measuring element and for the entire sensor
- Application data
- Temperature application range
- Date of initial commissioning
- Hours of operation under extreme conditions
- Number of sterilizations and CIP cycles

All Memosens 2.0 E sensors offer these advantages with the latest Liquiline transmitter software. All Memosens 2.0 sensors are backwards-compatible with previous software versions and offer the usual advantages of Memosens D-generation devices.

## 4 Incoming acceptance and product identification

### 4.1 Incoming acceptance

1. Verify that the packaging is undamaged.
  - ↳ Notify the supplier of any damage to the packaging.  
Keep the damaged packaging until the issue has been resolved.
2. Verify that the contents are undamaged.
  - ↳ Notify the supplier of any damage to the delivery contents.  
Keep the damaged goods until the issue has been resolved.
3. Check that the delivery is complete and nothing is missing.
  - ↳ Compare the shipping documents with your order.
4. Pack the product for storage and transportation in such a way that it is protected against impact and moisture.
  - ↳ The original packaging offers the best protection.  
Make sure to comply with the permitted ambient conditions.

If you have any questions, please contact your supplier or your local Sales Center.

### 4.2 Product identification

#### 4.2.1 Nameplate

The nameplate provides you with the following information on your device:

- Manufacturer identification
  - Order code
  - Extended order code
  - Serial number
  - Safety information and warnings
  - Certificate information
- ▶ Compare the information on the nameplate with the order.

#### 4.2.2 Product identification

##### Product page

[www.endress.com/cos81e](http://www.endress.com/cos81e)

##### Interpreting the order code

The order code and serial number of your product can be found in the following locations:

- On the nameplate
- In the delivery papers

##### Obtaining information on the product

1. Go to [www.endress.com](http://www.endress.com).
2. Call up the site search (magnifying glass).
3. Enter a valid serial number.
4. Search.
  - ↳ The product structure is displayed in a popup window.

5. Click on the product image in the popup window.
  - ↳ A new window (**Device Viewer**) opens. All of the information relating to your device is displayed in this window as well as the product documentation.

### 4.2.3 Manufacturer address

Endress+Hauser Conducta GmbH+Co. KG  
 Dieselstraße 24  
 D-70839 Gerlingen

## 4.3 Scope of delivery

The scope of delivery comprises:

- 1 sensor, version as ordered
- 1 x Brief Operating Instructions
- Safety instructions for the hazardous area (for sensors with Ex approval)
- Supplement for optional certificates that have been ordered

## 4.4 Certificates and approvals

 Certificates and approvals are optional, i.e. they depend on the product version.

### 4.4.1 CE mark

The product meets the requirements of the harmonized European standards. As such, it complies with the legal specifications of the EU directives. The manufacturer confirms successful testing of the product by affixing to it the **CE** mark.

### 4.4.2 Ex approvals

#### **COS81E-BG**

ATEX II 1G Ex ia op is IIC T6... T3 Ga

#### **COS81E-B4**

ATEX II 1G Ex ia op is IIC T6... T3 Ga

ATEX II 1D Ex ia op is IIIC T90°C... T200°C Da

#### **COS81E-IF**

IECEX Ex ia op is IIC T6... T3 Ga

#### **COS81E-I5**

IECEX Ex ia op is IIC T6... T3 Ga

IECEX Ex ia op is IIIC T90°C... T200°C Da

#### **COS81E-NG**

NEPSI Ex ia op is IIC T6/T4/T3 Ga

#### **COS81E-N5**

NEPSI Ex ia op is IIC T6/T4/T3 Ga

NEPSI Ex iaD op is 20 T90/T135/T200

#### **COS81E-MG**

INMETRO Ex ia op is IIC T6 ... T3 Ga

#### **COS81E-M5**

INMETRO Ex ia op is IIC T6 ... T3 Ga

INMETRO Ex ia op is IIIC T90°C... T200°C Da

#### **COS81E-JF**

JPN Ex ia op is IIC T6...T3 Ga

**COS81E-J5**

JPN Ex ia op is IIC T6...T3 Ga  
JPN Ex ia op is IIIC T90°C... T200°C Da

**COS81E-CI**

CSA C/US IS Class I Division 1 Groups A, B, C and D T6...T4  
CSA C/US Ex ia IIC T6...T4 Ga  
CSA C/US Class I Zone 0 AEx ia IIC T6...T4 Ga

**4.4.3 Hygienic compatibility****Regulation (EC) No. 1935/2004**

Meets the requirements of Regulation (EC) No. 1935/2004  
The product therefore meets the requirements for materials that come into contact with food.

**EHEDG**

The hygienic sensor is certified according to EHEDG Type EL-Class I.

**4.4.4 Pharmaceutical compatibility****ASME BPE**

Produced according to the criteria of the ASME BPE that is currently valid.

**Compliance with requirements derived from cGMP**

Certificate of conformity for pharmaceutical requirements, confirms conformity with biological reactivity test USP 87, USP 88 Class VI, FDA material conformity, TSE-/BSE-free, surface roughness

**FDA compatibility**

All parts in contact with medium comply with the relevant regulations of the FDA.

**Hazardous area versions**

For operation in FDA processes, another FDA-approved seal must be installed before the process seal (for example Unifit CPA842). Doing so will sufficiently separate the process from the Ex connection.

**4.4.5 Additional certification****Inspection certificate in accordance with EN 10204 3.1**

A test certificate 3.1 in accordance with EN 10204 is supplied depending on the version (→ Product Configurator on the product page).

**4.4.6 Other standards and guidelines****EAC**

The product has been certified according to guidelines TP TC 004/2011 and TP TC 020/2011 which apply in the European Economic Area (EEA). The EAC conformity mark is affixed to the product.

**CRN approval**

As the sensor can be operated at a nominal pressure greater than 15 psi (approx. 1 bar), it has been registered according to CSA B51 ("Boiler, pressure vessel, and pressure piping code"; category F) with a CRN (Canadian Registration Number) in all Canadian provinces.

**4.4.7 Test reports****Manufacturer's certificate**

Stating the individual final test data

**Surface roughness test**

Stainless steel surfaces in contact with medium tested to  $\leq R_a 0.38 \mu\text{m}$ .

## 5 Installation

### 5.1 Installation conditions

#### 5.1.1 Dimensions

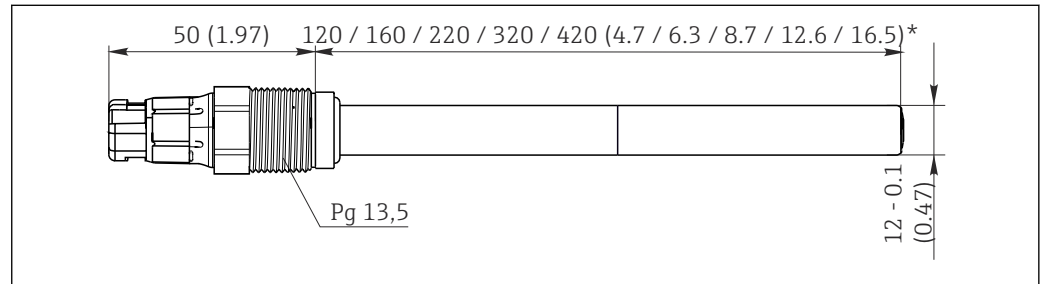

3 Dimensions in mm (inch)

#### 5.1.2 Orientation

The sensor's spot cap can have either a c-shaped or u-shaped design.

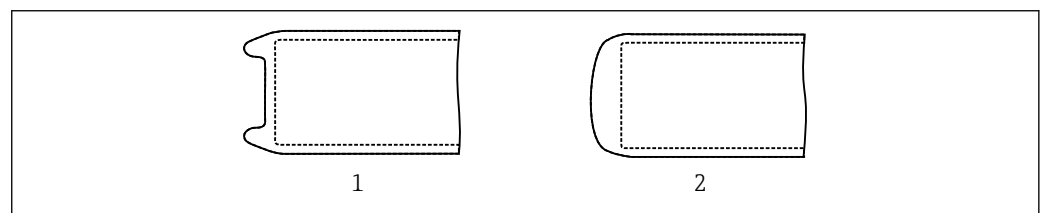

4 Design of spot cap

- 1 u-shaped
- 2 c-shaped

#### 5.1.3 Mounting location

1. Choose a mounting location that is easy to access.
2. Ensure that upright posts and assemblies are fully secured and vibration-free.
3. Choose a mounting location with an oxygen concentration that is typical for the application.

#### 5.1.4 Hygienic requirements

The use of an EHEDG-certified assembly is a prerequisite for the easy-to-clean installation of a 12-mm sensor in accordance with EHEDG requirements.

Furthermore, the instructions regarding the hygienic installation and operation of the assembly in the relevant Operating Instructions must be adhered to.

The Special Documentation for hygienic applications must be observed for hygienic operation.

## 5.2 Mounting the sensor

### 5.2.1 Measuring system

A complete measuring system comprises:

- a Memosens COS81E oxygen sensor
- Measuring cable CYK10
- A transmitter, e.g. Liquiline CM42, Liquiline CM44x/R, Liquiline CM44P, Liquiline Compact CM72/82, Liquiline Mobile CML18
- Optional: an assembly, e.g. Unifit CPA842 fixed installation assembly, Flowfit CYA21 flow assembly or Cleanfit CPA875 retractable assembly
- Optional: connection to an analog fermenter controller via the Memosens analog converter CYM17

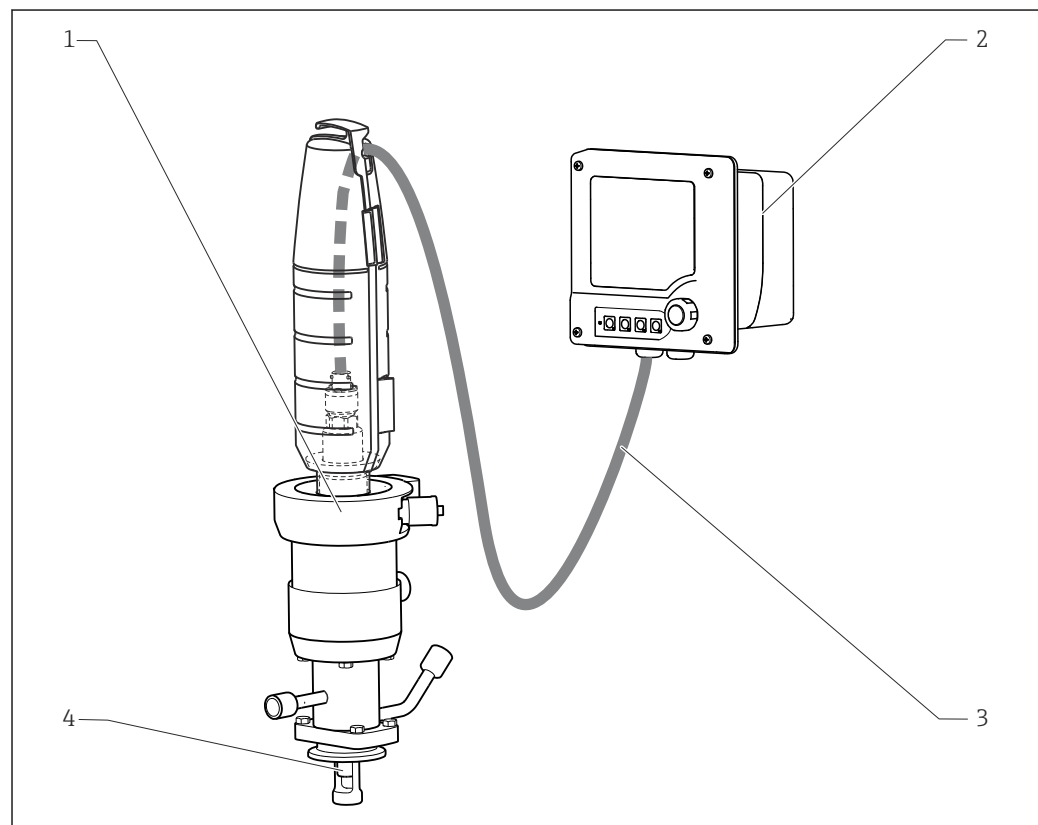

5 Example of a measuring system with Memosens COS81E

- 1 Retractable assembly Cleanfit CPA875
- 2 Liquiline CM42 transmitter
- 3 Measuring cable CYK10
- 4 Oxygen sensor Memosens COS81E

### 5.2.2 Installing at a measuring point

Must be installed in a suitable assembly (depending on the application).

#### **⚠ WARNING**

##### **Electrical voltage**

In the event of a fault, non-grounded metallic assemblies may be live and as such are not safe to touch!

- ▶ When using metallic assemblies and installation equipment, national grounding provisions must be observed.



For complete installation of a measuring point, proceed as follows:

1. Install the retractable assembly or flow assembly (if used) in the process
2. Connect the water supply to the rinse connections (if you are using an assembly with a cleaning function)
3. Connect the cable to the sensor and transmitter
4. Supply power to the transmitter
5. Install and connect the oxygen sensor in the assembly

**NOTICE**

**Incorrect installation**

Cable open circuit, loss of sensor due to cable separation, unscrewing of spot cap!

- ▶ Do not install the sensor freely suspended from the cable!
- ▶ Screw the sensor into the assembly, ensuring that the cable is not twisted.
- ▶ Hold the sensor body steady during installation or removal. Turn **only at the hexagonal nut** of the armored coupling. Otherwise the spot cap might be unscrewed and will then remain in the assembly or process.
- ▶ Avoid exerting excessive tensile force on the cable (e.g. through jerky pulling movements).
- ▶ Choose a mounting location that is easy to access for later calibrations.
- ▶ Follow the instructions for installing sensors in the Operating Instructions for the assembly used.

### 5.3 Installation examples

#### 5.3.1 Permanent installation Unifit CPA842

The permanent installation assembly CPA842 enables easy adaptation of a sensor to nearly any process connections from Ingold nozzles to Varivent or Tri-Clamp connections. This kind of installation is very well suited for tanks and larger pipes. This enables a defined immersion depth of the sensor into the medium in the simplest way.

#### 5.3.2 Flow assembly CYA680

The flow assembly is available in various nominal diameters and materials. It can be installed both in horizontal and vertical pipes. The assembly can be operated with 1 or 2 sensors.

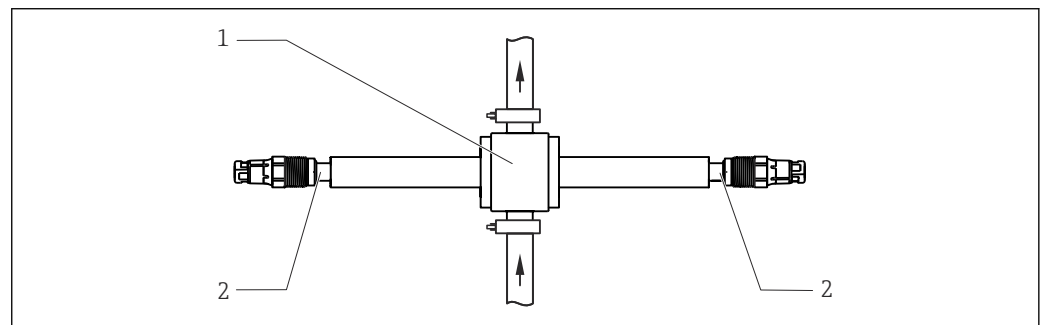

6 Flow assembly CYA680  
 1 Flow chamber of assembly  
 2 Installed sensor Memosens COS81E

A0042963

### 5.3.3 Flow assembly Flowfit CYA21 for water treatment and processes

The compact stainless steel assembly offers space for a 12-mm sensor with a length of 120 mm. The assembly has a low sampling volume and, with the 6-mm connections, it is best suited for residual oxygen measurement in water treatments and boiler feedwater. The flow comes from below.

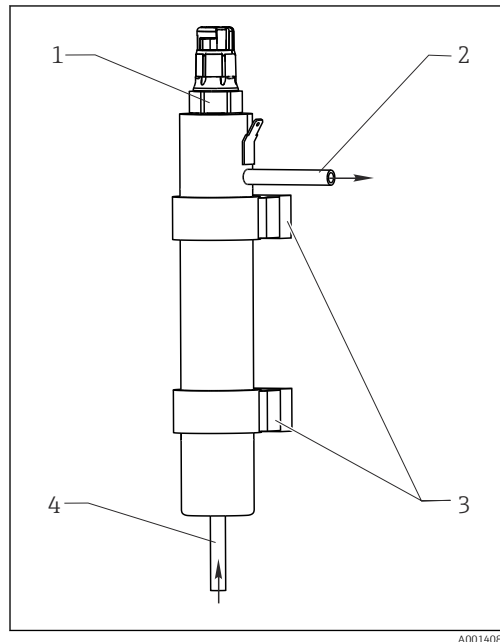

7 Flow assembly

- 1 Installed sensor Memosens COS81E
- 2 Drain
- 3 Wall mount (clamp D29)
- 4 Inflow

### 5.3.4 Retractable assembly Cleanfit CPA875 or Cleanfit CPA450

The assembly is designed for installation on vessels and pipes. Suitable nozzles must be available for this.

Install the assembly in a place with uniform flow conditions. The minimum pipe diameter is DN 80.

**Installation position for COS81E-\*\*\*\*U\*\*\* (with u-shaped spot cap)**

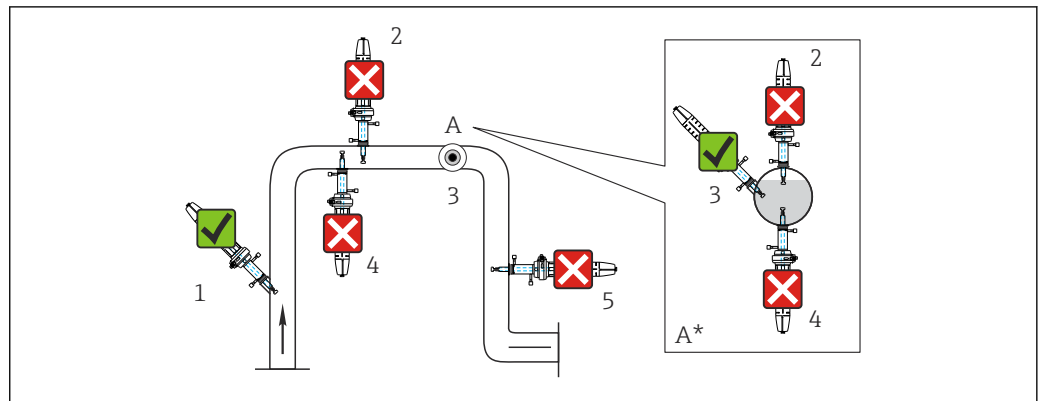

8 Suitable and unsuitable installation positions for Memosens COS81E with u-shaped spot cap and retractable assembly

- 1 Ascending pipe, best position
- 2 Horizontal pipe, sensor top down, impermissible due to air cushion or foam bubble forming
- 3 Horizontal pipe, lateral installation, with suitable installation angle
- 4 Upside-down installation, unsuitable
- 5 Down pipe, impermissible
- A Detail A (top view)
- A\* Detail A, turned by 90° (side view)

- ✓ Possible installation angle
- ✗ Inadmissible installation angle

**Installation position for COS81E-\*\*\*\*C\*\*\* (with c-shaped spot cap)**

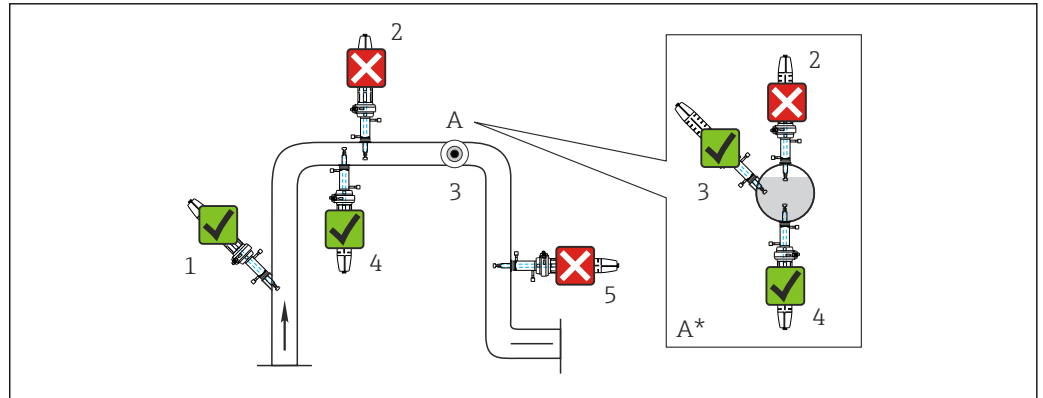

9 Suitable and unsuitable installation positions for Memosens COS81E with c-shaped spot cap and retractable assembly

- 1 Ascending pipe, best position
- 2 Horizontal pipe, sensor top down, impermissible due to air cushion or foam bubble forming
- 3 Horizontal pipe, lateral installation with permissible installation angle (acc. to sensor version)
- 4 Upside-down installation, only in conjunction with c-shaped spot cap
- 5 Down pipe, impermissible

- ✓ Possible installation angle
- ✗ Inadmissible installation angle

**NOTICE**

**Sensor not in the medium all the way, buildup, upside-down installation**

These can all cause incorrect measurements!

- ▶ Do not install assembly at points where air pockets or bubbles may form.
- ▶ Avoid or regularly remove buildup on the spot cap.
- ▶ Do not install the sensor COS81E-\*\*\*\*U (u-shaped) upside down.

## 5.4 Post-installation check

1. Are the sensor and cable undamaged?
2. Is the orientation correct?
3. Is the sensor installed in an assembly and is not suspended from the cable?
4. Avoid the penetration of moisture.

## 6 Electrical connection

**⚠ WARNING**

**Device is live!**

Incorrect connection may result in injury or death!

- ▶ The electrical connection may be performed only by an electrical technician.
- ▶ The electrical technician must have read and understood these Operating Instructions and must follow the instructions contained therein.
- ▶ **Prior** to commencing connection work, ensure that no voltage is present on any cable.

### 6.1 Connecting the sensor

The electrical connection of the sensor to the transmitter is established using the measuring cable CYK10.

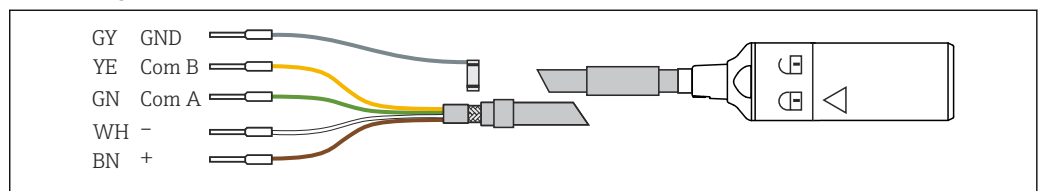

10 Measuring cable CYK10

### 6.2 Ensuring the degree of protection

Only the mechanical and electrical connections which are described in these instructions and which are necessary for the required, designated use, may be carried out on the device delivered.

- ▶ Exercise care when carrying out the work.

Otherwise, the individual types of protection (Ingress Protection (IP), electrical safety, EMC interference immunity) agreed for this product can no longer be guaranteed due, for example to covers being left off or cable (ends) that are loose or insufficiently secured.

### 6.3 Post-connection check

Device condition and specifications	Action
Are the sensorprocess spectrometer, assembly or cables free from damage on the outside?	▶ Perform a visual inspection.
Electrical connection	Action
Are the mounted cables strain-relieved and not twisted?	▶ Perform a visual inspection. ▶ Untwist the cables.
Is a sufficient length of the cable cores stripped, and are the cores positioned in the terminal correctly?	▶ Perform a visual inspection. ▶ Pull gently to check they are seated correctly.
Are all the screw terminals properly tightened?	▶ Tighten the screw terminals.
Are all cable entries mounted, tightened and leak-tight?	▶ Perform a visual inspection.
Are all cable entries installed downwards or mounted laterally?	In the case of lateral cable entries: ▶ Point cable loops downward so that water can drip off.

## 7 Commissioning

### 7.1 Function check

Prior to initial commissioning, ensure that:

- The sensor is correctly installed
- The electrical connection is correct

If using an assembly with automatic cleaning function:

- ▶ Check that the cleaning medium (water or air, for example) is connected correctly.

#### **WARNING**

##### **Escaping process medium**

Risk of injury from high pressure, high temperatures or chemical hazards!

- ▶ Before applying pressure to an assembly with cleaning system, ensure that the system has been connected correctly.
- ▶ If you cannot reliably establish the correct connection, do not install the assembly in the process.

1. At the transmitter, enter all the settings specific to the parameters and measuring point. These include the air pressure during calibration and measurement or the salinity, for instance.
2. Check whether a calibration/adjustment is necessary.

The oxygen measuring point is then ready to measure.

 Following commissioning, the sensor must be serviced at regular intervals, as only then can reliable measurement be guaranteed.

 Operating Instructions for the transmitter used, such as BA01245C if using the Liquiline CM44x or Liquiline CM44xR.

### 7.2 Calibration and adjustment

The sensor is calibrated and adjusted in the factory prior to delivery and is therefore ready for immediate use.

A recalibration or readjustment is required in the following situations:

- Changes due to process conditions, e.g. for Cleaning in Place (CIP), Sterilization in Place (SIP) and autoclaving
- Changes due to stress: temperature and/or chemicals (cleaning)
- Following a spot cap replacement

#### **Recommended procedure after replacing a spot cap**

First calibrate and adjust the sensor at the zero point and then in the presence of oxygen.

Calibration and adjustment can also be monitored or renewed cyclically (at typical time intervals, depending on operating experience), e.g. within the context of system monitoring.

### 7.2.1 Types of calibration

The following types of calibration are possible:

- Zero point
  - Single-point calibration in nitrogen or COY8 zero-point gel
  - Numeric input
- Point at oxygen
  - Air, water vapor-saturated (recommended)
  - Air-saturated water
  - Air, variable
  - Test gas calibration
  - Numeric input
  - Sample calibration
- Fermenter scaling
- Temperature adjustment
- Spot cap replacement

### 7.2.2 Zero point calibration

The zero point is not so important when working with relatively high concentrations of oxygen. In these types of application, a zero point calibration is required only after the spot cap has been replaced.

However, once oxygen sensors are used at low concentrations and in the trace range, they must also be calibrated at the zero point.

Zero point calibrations are demanding as the ambient medium - usually air - already has a high oxygen content. This oxygen must be excluded for zero point calibration of the sensor.

A calibration with zero-point gel COY8 can be used for this purpose:

The oxygen-depleting gel COY8 creates an oxygen-free medium for zero point calibration.

Prior to sensor zero point calibration, check the following:

- Is the sensor signal stable?
- Has the adjustment time of 30 min - 40 min for the zero-point gel COY8 elapsed?
- Is the value displayed plausible?

1. If the sensor signal is stable:

Calibrate the zero point.

2. If necessary:

Adjust the sensor by accepting the calibration data.

 If the oxygen sensor is calibrated too early, this can result in an incorrect zero point.

Rule of thumb: operate the sensor for at least 30 min in the COY8 zero-point gel.

 Follow the instructions in the kit documentation enclosed with the COY8 zero-point gel.

### 7.2.3 Calibration in oxygen with 100% rH

1. Remove the sensor from the medium.

2. Clean the outside of the sensor carefully with a damp cloth.

3. Suspend the sensor just above the surface of the water.

Do not immerse the sensor.

4. Allow a temperature compensation time of approx. 20 minutes for the sensor in the ambient air. Make sure that the sensor is not exposed to any direct ambient effects (direct sunlight, drafts) during this time.

5. Is the measured value display on the transmitter stable:  
Perform the calibration in accordance with the Operating Instructions for the transmitter. Pay particular attention to the software settings for the stability criteria for calibration and for the ambient pressure.
  6. Where necessary:  
Adjust the sensor by accepting the calibration data.
  7. Then place the sensor back into the medium.
  8. Deactivate the hold status at the transmitter.
- Follow the calibration instructions in the Operating Instructions for the transmitter used.
- i** The constants  $K_{sv}$  and  $\tau_0$  of the Stern-Volmer equation are determined at both calibration points (point in oxygen and zero point). The calibration quality index provides an indication of the quality of the calibration in relation to the first reference calibration of the spot cap. Therefore it is important to run the **Change sensor cap** command in the calibration menu of the transmitter before every initial calibration of a spot cap.

#### 7.2.4 Calculation example for the calibration value

As a check, you can calculate the expected calibration value (transmitter display) as shown in the following example (salinity is 0).

1. Determine the following:
  - Ambient temperature for the sensor (air temperature in the case of the **Air 100% rh** or **Air variable** calibration methods, water temperature in the case of the **H2O air-saturated** calibration method)
  - The altitude above sea level
  - The current air pressure (= relative air pressure based on sea level) at the time of calibration. (If indeterminable, use 1013 hPa.)
2. Determine the following:
  - The saturation value S acc. to Table 1
  - The altitude factor K acc. to Table 2

Table 1

T [°C (°F)]	S [mg/l=ppm]	T [°C (°F)]	S [mg/l=ppm]	T [°C (°F)]	S [mg/l=ppm]	T [°C (°F)]	S [mg/l=ppm]
0 (32)	14.64	11 (52)	10.99	21 (70)	8.90	31 (88)	7.42
1 (34)	14.23	12 (54)	10.75	22 (72)	8.73	32 (90)	7.30
2 (36)	13.83	13 (55)	10.51	23 (73)	8.57	33 (91)	7.18
3 (37)	13.45	14 (57)	10.28	24 (75)	8.41	34 (93)	7.06
4 (39)	13.09	15 (59)	10.06	25 (77)	8.25	35 (95)	6.94
5 (41)	12.75	16 (61)	9.85	26 (79)	8.11	36 (97)	6.83
6 (43)	12.42	17 (63)	9.64	27 (81)	7.96	37 (99)	6.72
7 (45)	12.11	18 (64)	9.45	28 (82)	7.82	38 (100)	6.61
8 (46)	11.81	19 (66)	9.26	29 (84)	7.69	39 (102)	6.51
9 (48)	11.53	20 (68)	9.08	30 (86)	7.55	40 (104)	6.41
10 (50)	11.25						



Table 2

Altitude [m (ft)]	K	Altitude [m (ft)]	K	Altitude [m (ft)]	K	Altitude [m (ft)]	K
0 (0)	1.000	550 (1800)	0.938	1050 (3450)	0.885	1550 (5090)	0.834
50 (160)	0.994	600 (1980)	0.932	1100 (3610)	0.879	1600 (5250)	0.830
100 (330)	0.988	650 (2130)	0.927	1150 (3770)	0.874	1650 (5410)	0.825
150 (490)	0.982	700 (2300)	0.922	1200 (3940)	0.869	1700 (5580)	0.820
200 (660)	0.977	750 (2460)	0.916	1250 (4100)	0.864	1750 (5740)	0.815
250 (820)	0.971	800 (2620)	0.911	1300 (4270)	0.859	1800 (5910)	0.810
300 (980)	0.966	850 (2790)	0.905	1350 (4430)	0.854	1850 (6070)	0.805
350 (1150)	0.960	900 (2950)	0.900	1400 (4600)	0.849	1900 (6230)	0.801
400 (1320)	0.954	950 (3120)	0.895	1450 (4760)	0.844	1950 (6400)	0.796
450 (1480)	0.949	1000 (3300)	0.890	1500 (4920)	0.839	2000 (6560)	0.792
500 (1650)	0.943						

3. Calculate factor L:

$$L = \frac{\text{Relative air pressure at calibration}}{1013 \text{ hPa}}$$

4. Determine the M factor:

- M = 1.02 (for Air 100% rh calibration method)
- M = 1.00 (for H2O air-saturated calibration method)

5. Calculate calibration value C:

$$C = S \cdot K \cdot L \cdot M$$

**Example**

- Air calibration at 18 °C (64 °F), altitude 500 m (1650 ft) above sea level, current air pressure 1009 hPa
- S = 9.45 mg/l, K = 0.943, L = 0.996, M=1.00
- Calibration value C = 8.88 mg/l.

 Factor K in the table is not required if the measuring device returns the absolute air pressure  $L_{abs}$  (air pressure depending on altitude) as the measured value. The formula for calculation is then:  $C = S \cdot L_{abs}$ .

### 7.2.5 Measured value filter

In the sensor setup of the transmitter (e.g. CM44x Release 1.09.00 and higher), different measured value filters can be configured for COS81E and saved in the sensor.

The following measured value filters are available:

- Standard  
Responsive filter that quickly captures all changes in the oxygen content (default)
- Life science
  - Standard: optimized filter for use of the sensor in fermenter applications
  - Strong: strong filter for use of the sensor in fermenter applications in which oxygen regulation is complicated by small accumulations of air bubbles on the sensor due to the consistency of the medium

## 8 Diagnostics and troubleshooting

### 8.1 General troubleshooting

- ▶ If one of the following problems is present:  
Check the measuring system in the order shown.

Problem	Check	Solution
Nothing displayed, no reaction from the sensor	Power supplied to the transmitter?	<ul style="list-style-type: none"> <li>▶ Establish the power supply.</li> <li>▶ Switch on channel on transmitter.</li> </ul>
	Sensor cable connected correctly?	<ul style="list-style-type: none"> <li>▶ Establish correct connection.</li> </ul>
	Buildup on the spot cap?	<ul style="list-style-type: none"> <li>▶ Clean the spot cap or luminescence layer carefully with a soft cloth.</li> </ul>
Displayed value too high	Is sensor calibrated/adjusted? Measured value in air not $100 \pm 2$ %SAT?	<ul style="list-style-type: none"> <li>▶ Recalibrate/readjust.               <ul style="list-style-type: none"> <li>↳ When calibrating, enter the current air pressure at the transmitter.</li> </ul> </li> </ul>
	Displayed temperature clearly too low?	<ul style="list-style-type: none"> <li>▶ Check the sensor, contact the Service Department if necessary.</li> </ul>
Displayed value too low	Is sensor calibrated/adjusted? Measured value in air not $100 \pm 2$ %SAT?	<ul style="list-style-type: none"> <li>▶ Recalibrate/readjust.               <ul style="list-style-type: none"> <li>↳ When calibrating, enter the current air pressure at the transmitter.</li> </ul> </li> </ul>
	Displayed temperature clearly too high?	<ul style="list-style-type: none"> <li>▶ Check the sensor, contact the Service Department if necessary.</li> </ul>
Display value fluctuating	Are there air bubbles on the spot cap?	<ol style="list-style-type: none"> <li>1. Change the installation angle.</li> <li>2. If necessary, change the cap type from a u-shaped to a c-shaped cap.</li> </ol>
Display in Vol% or %SAT not plausible	Medium pressure has not been taken into account	<ul style="list-style-type: none"> <li>▶ Enter medium pressure on transmitter.</li> </ul>
F005 after transmitter replacement	Measured value filter setting changed?	Update the transmitter to the most recent software version or, on the transmitter with the latest software version, adjust the filter setting to the medium again and continue using the older transmitter software.

-  Pay attention to the troubleshooting information in the Operating Instructions for the transmitter.

Check the transmitter if necessary.

## 9 Maintenance

Take all the necessary precautions in time to ensure the operational safety and reliability of the entire measuring system.

### NOTICE

#### Effects on process and process control!

- ▶ When carrying out any work on the system, bear in mind any potential impact this could have on the process control system and the process itself.
- ▶ For your own safety, only use genuine accessories. With genuine parts, the function, accuracy and reliability are also ensured after maintenance work.

### 9.1 Maintenance schedule

Maintenance cycles depend to a great extent on the operating conditions.

The following rule of thumb applies:

- Constant conditions, e.g. power plant = long cycles (1/2 year)
- Widely varying conditions, e.g. daily CIP or SIP cleaning, fluctuating process pressure = short cycles (1 month and shorter)

The following method helps you determine the necessary intervals:

1. Inspect the sensor one month after commissioning. To do so, remove the sensor from the medium and dry it carefully.
  2. Visually check the spot cap.
    - ↳ There should be no green coloration or air bubbles visible on the exterior. Otherwise, replace the spot cap.
  3. After 10 minutes, measure the oxygen saturation index in air.
    - ↳ Decide using the results:
      - a) Measured value not  $100 \pm 2$  % SAT? → Service the sensor.
      - b) Measured value =  $100 \pm 2$  % SAT? → Double the length of time to the next inspection.
  4. Proceed as indicated in Step 1 after two, four and eight months.
    - ↳ This allows you to determine the optimum maintenance interval for your sensor.
-  Particularly in the case of widely fluctuating process conditions, damage may occur to the luminescence layer even within a maintenance cycle. You can recognize this by implausible sensor behavior.

### 9.2 Maintenance tasks

The following tasks must be performed:

1. Clean the sensor and spot cap.
2. Replace wear parts or consumables.
3. Check measurement function.
4. Recalibrate (if desired or necessary).
  - ↳ Follow the Operating Instructions for the transmitter.

#### 9.2.1 Cleaning exterior of sensor

The measurement can be corrupted by sensor fouling or malfunction due to the following, for example:

Buildup on the spot cap

- ↳ This causes a longer response time.

The sensor must be cleaned at regular intervals for reliable measurement results. The frequency and intensity of the cleaning process depend on the medium.

Clean the sensor:

- Before every calibration
- At regular intervals during operation as necessary
- Before returning it for repair

Type of contamination	Cleaning
Salt deposits	<ol style="list-style-type: none"> <li>1. Immerse the sensor in drinking water.</li> <li>2. Then rinse it with copious amounts of water.</li> </ol>
Dirt particles on the sensor shaft and shaft sleeve ( <b>not spot cap!</b> )	<ul style="list-style-type: none"> <li>▶ Clean sensor shaft and sleeve with water and a suitable sponge.</li> </ul>
Dirt particles on the spot cap	<ul style="list-style-type: none"> <li>▶ Clean the spot cap with water. No mechanical cleaning.</li> </ul>

- ▶ After cleaning:  
Rinse with copious amounts of clean water.

### 9.2.2 Clean the sensor optics

The optics need to be cleaned only if there is visible buildup on the optical waveguide or boundary area.

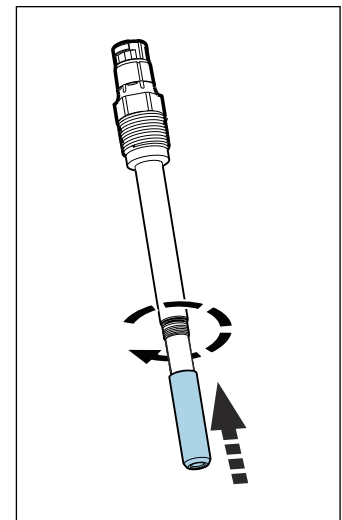
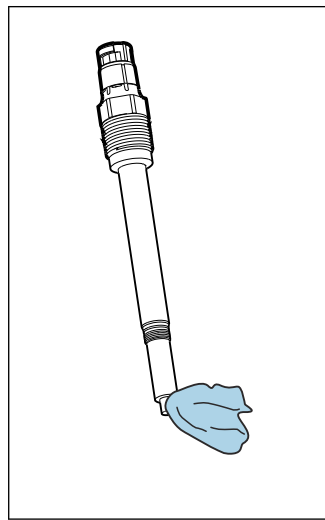
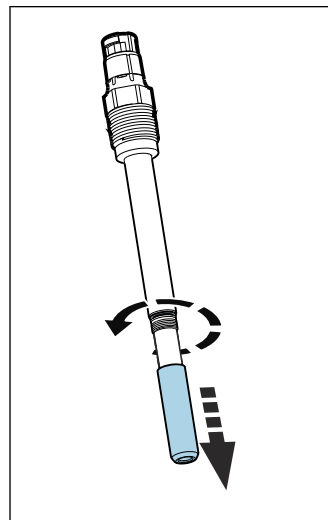

1. Unscrew the spot cap from the sensor head.
2. Carefully clean the optical surface with a soft cloth until the buildup is fully removed. If necessary wet the cloth with drinking water or distilled water (preferably use the cleaning cloth supplied with the COV81 maintenance kit) .
3. Dry the optical surface and screw on a functioning spot cap.
4. At the transmitter, execute the **Sensor cap change** command and then perform the necessary calibrations.

#### NOTICE

##### Damage, scratches on optical surface

Distorted measured values

- ▶ Make sure that the optical surface is not scratched or damaged in any other way.

## 10 Repair

### 10.1 General notes

- ▶ Only use spare parts from Endress + Hauser to guarantee the safe and stable functioning of the device.

Detailed information on the spare parts is available at:  
[www.endress.com/device-viewer](http://www.endress.com/device-viewer)

### 10.2 Spare parts and consumables

#### Memosens COV81

- Maintenance kit for COS81E
- Scope of delivery of the Memosens COV81 maintenance kit is based on the configuration:
  - Spot cap
  - O-ring mounting tool
  - Cleaning cloth for optics
  - O-rings
  - Certificate
- Ordering information: [www.endress.com/cos81e](http://www.endress.com/cos81e) under "Accessories/spare parts"

### 10.3 Return

The product must be returned if repairs or a factory calibration are required, or if the wrong product was ordered or delivered. As an ISO-certified company and also due to legal regulations, Endress+Hauser is obliged to follow certain procedures when handling any returned products that have been in contact with medium.

To ensure the swift, safe and professional return of the device:

- ▶ Refer to the website [www.endress.com/support/return-material](http://www.endress.com/support/return-material) for information on the procedure and conditions for returning devices.

The product must be returned if repairs or a factory calibration are required, or if the wrong product was ordered or delivered.

To ensure safe, professional and swift product returns, please contact your local Sales Center for information on the procedure to be followed and general conditions.

### 10.4 Spare parts

Parts of the sensor are subject to wear during operation. By taking suitable measures, you can restore the normal operating function.

Corrective action	Reason
Replace process seals	Visible damage to a process seal
Replace spot cap	<ul style="list-style-type: none"> <li>▪ Luminescence layer is damaged or can no longer be cleaned</li> <li>▪ Visible damage to the O-ring</li> </ul>

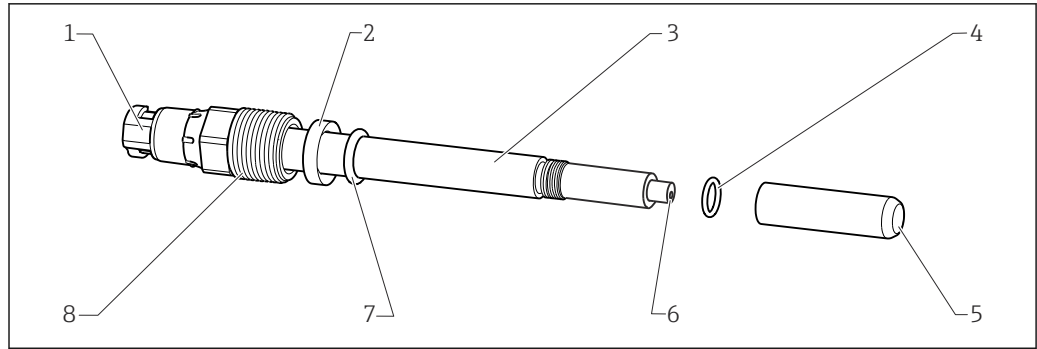

A0027181

11 Memosens COS81E

- |   |  |   |   |
|---|--|---|---|
| 1 | Memosens plug-in head with optics assembly | 5 | Spot cap                                  |
| 2 | Thrust collar                              | 6 | Optical waveguide with temperature sensor |
| 3 | Sensor shaft                               | 7 | Process seal 10.77 x 2.62 mm              |
| 4 | O-ring sensor shaft                        | 8 | Process connection Pg 13.5                |

**i** The suitability of the selected materials for use in the process must be assessed during the product configuration.

Process conditions that go beyond the resistance range of the materials may shorten the operating life of the materials and make maintenance necessary.

The sensor's spot cap can have either a c-shaped or u-shaped design.

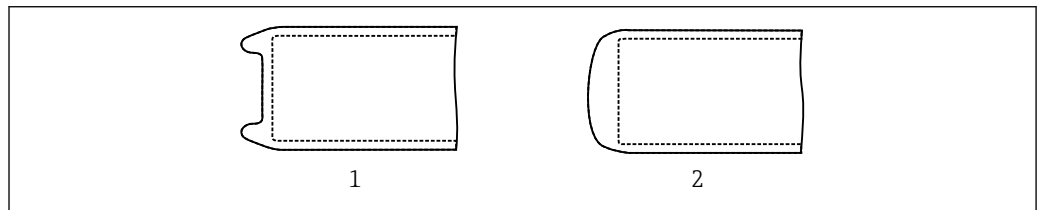

A0034733

12 Design of spot cap

- 1 u-shaped
- 2 c-shaped

### 10.4.1 Replacing sealing rings

It is compulsory to replace the sealing ring if it is visibly damaged. Only use original sealing rings.

The following O-rings can be replaced:

- Sealing ring for shaft sleeve: item 4
- Sealing ring towards process (conductive for Ex): item 8 7

#### Replacing the sealing ring for the shaft sleeve

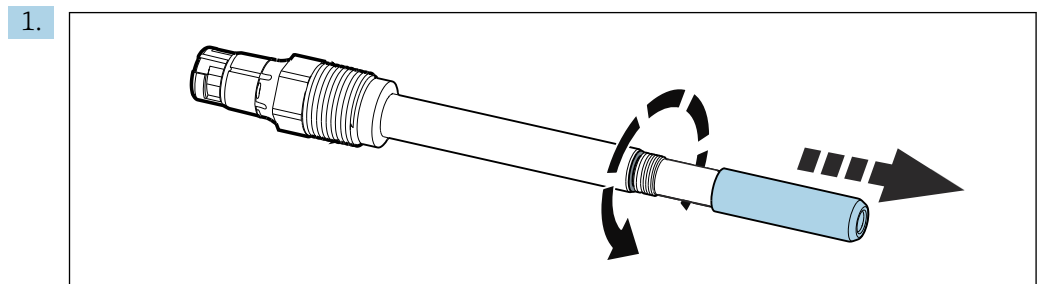

A0043010

Unscrew spot cap and remove.

2.

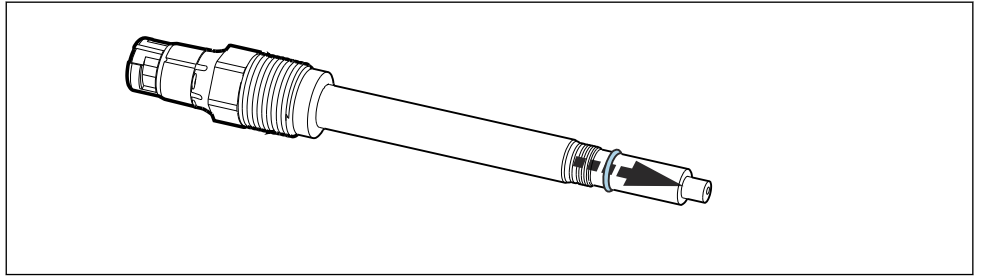

A0034713

Remove the old O-ring above the thread on the shaft.

3.

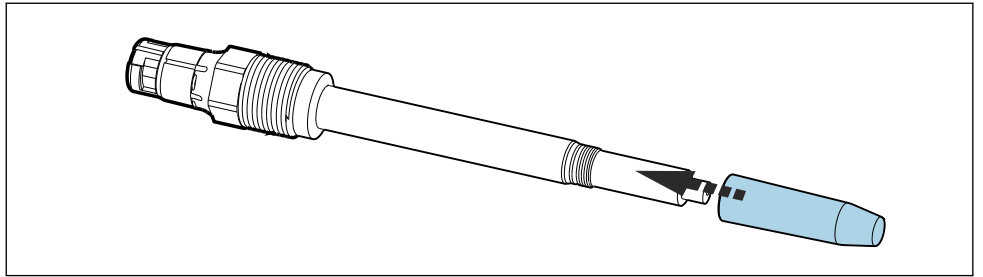

A0034715

Push the mounting tool from below onto the shaft until it sits over the thread.

4.

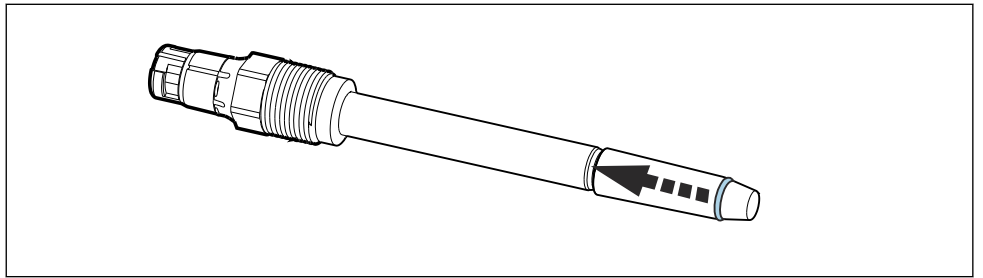

A0034717

Slide the new O-ring over the mounting tool into the position above the thread.

5.

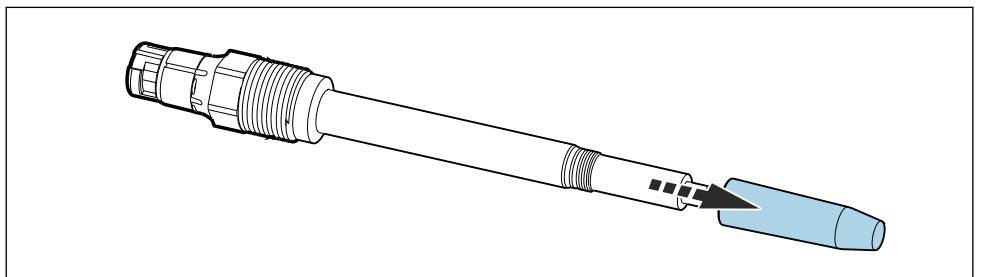

A0043012

Remove the mounting tool.

6.

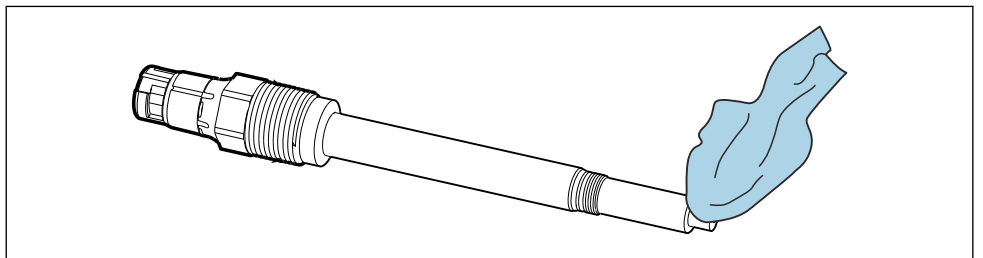

A0043015

Clean the sensor optics carefully using the cloth provided.

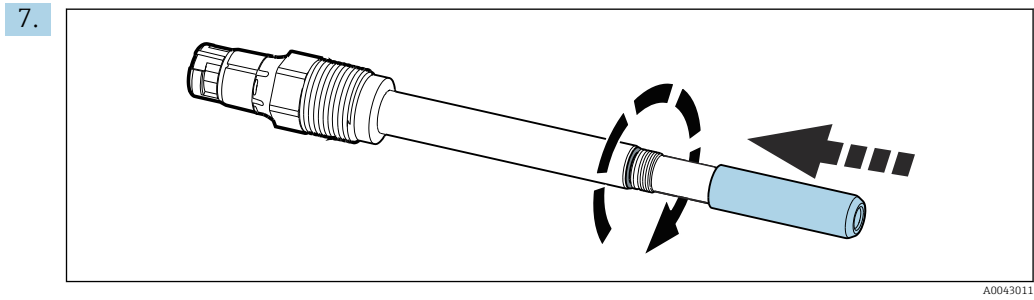

Screw on the spot cap.

**Replacing the sealing ring towards the process**

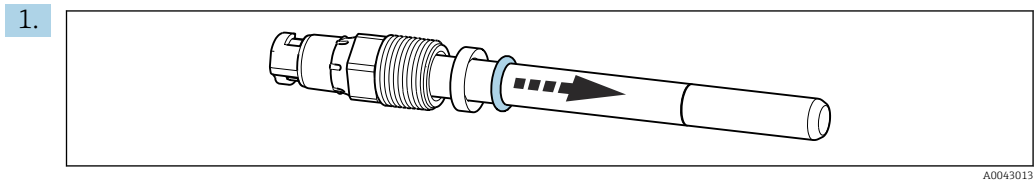

Remove the old O-ring on the process connection in the direction of the spot cap.

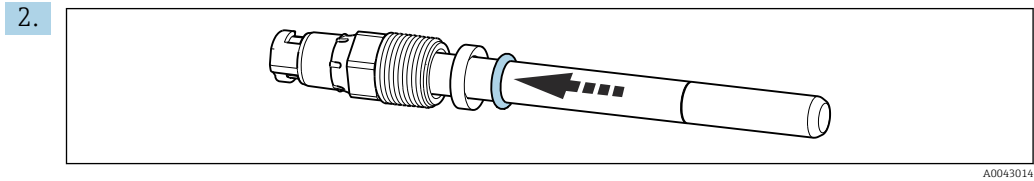

Fit the new O-ring over the spot cap and push it as far as the process connection.

**10.4.2 Replacing the spot cap**

The spot cap must be replaced if it is visibly damaged or the sensor measurement quality is not sufficient. Only use original spot caps.

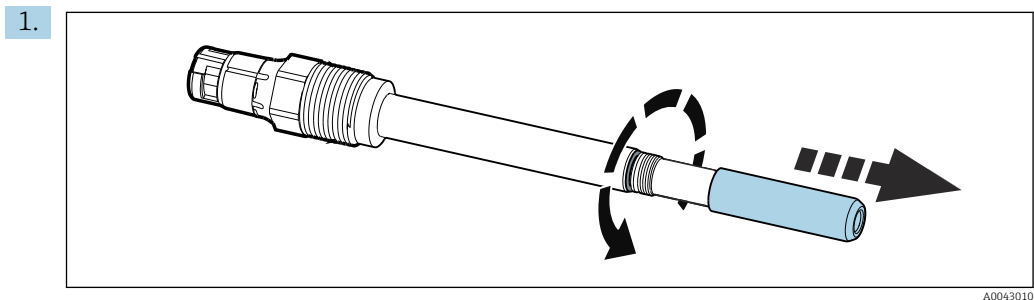

Unscrew the old spot cap and remove.

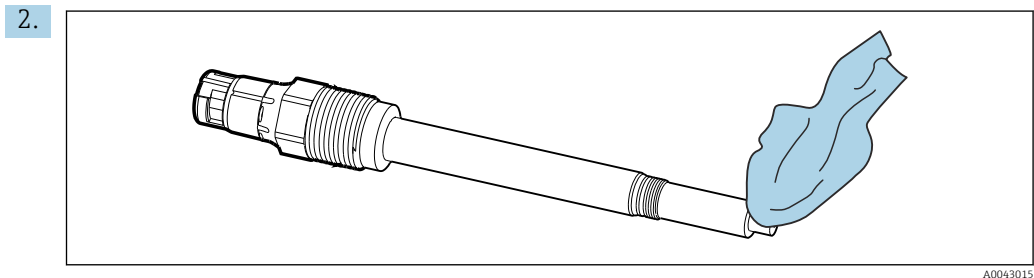

Clean the sensor optics carefully using the cloth provided.



3. Reset the cap counters.
  - ↳ Warnings can be configured for the spot cap counters to assist with sensor maintenance.

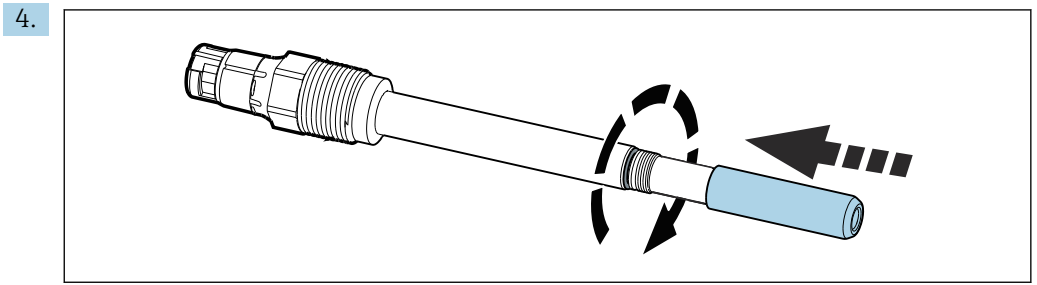

Screw on the new spot cap.

5. Calibrate the sensor or check the measuring function. → 📄 22

## 10.5 Checking the measurement function

1. Remove the sensor from the medium.
2. Clean and dry the .
3. After about 10 minutes, measure the oxygen saturation index in air (without recalibration).
  - ↳ The measured value should be at  $100 \pm 2$  % SAT.

## 10.6 Disposal



If required by the Directive 2012/19/EU on waste electrical and electronic equipment (WEEE), the product is marked with the depicted symbol in order to minimize the disposal of WEEE as unsorted municipal waste. Do not dispose of products bearing this marking as unsorted municipal waste. Instead, return them to Endress+Hauser for disposal under the applicable conditions.

## 11 Accessories

The following are the most important accessories available at the time this documentation was issued.

- ▶ For accessories not listed here, please contact your Service or Sales Center.

### 11.1 Device-specific accessories

#### 11.1.1 Assemblies (selection)

 COS81E with 220 mm length is suitable for all assemblies requiring an installation length of 225 mm.

##### Cleanfit CPA875

- Retractable process assembly for sterile and hygienic applications
- For in-line measurement with standard sensors with 12 mm diameter, e.g. for pH, ORP, oxygen
- Product Configurator on the product page: [www.endress.com/cpa875](http://www.endress.com/cpa875)

 Technical Information TI01168C

##### Flowfit CPA240

- pH/redox flow assembly for processes with stringent requirements
- Product Configurator on the product page: [www.endress.com/cpa240](http://www.endress.com/cpa240)

 Technical Information TI00179C

##### Unifit CPA842

- Installation assembly for food, biotechnology and pharmaceuticals
- With EHEDG and 3A certificate
- Product Configurator on the product page: [www.endress.com/cpa842](http://www.endress.com/cpa842)

 Technical Information TI00306C

##### Cleanfit CPA450

- Manual retractable assembly for installing sensors with a diameter of 12 mm and a length of 120 mm in tanks and pipes
- Product Configurator on the product page: [www.endress.com/cpa450](http://www.endress.com/cpa450)

 Technical Information TI00183C

##### Flowfit CYA21

- Universal assembly for analysis systems in industrial utilities
- For sensors with  $\varnothing$  12 mm and length 120 mm
- Compact stainless steel assembly with low sampling volume
- Product Configurator on the product page: [www.endress.com/CYA21](http://www.endress.com/CYA21)

 Technical Information TI01441C

##### CYA680

- Flow assembly for hygienic sensors
- For sensor installation in pipes
- Suitable for cleaning in place (CIP) and sterilization in place (SIP)
- Certified biocompatibility as per USP Class VI, FDA-listed seals and hygienic, electropolished surfaces  $R_a=0.38 \mu\text{m}$  (15  $\mu\text{inch}$ )
- Product Configurator on the product page: [www.endress.com/cya680](http://www.endress.com/cya680)

 Technical Information TI01295C

### 11.1.2 Measuring cable

#### Memosens data cable CYK10

- For digital sensors with Memosens technology
- Product Configurator on the product page: [www.endress.com/cyk10](http://www.endress.com/cyk10)

 Technical Information TI00118C

#### Memosens data cable CYK11

- Extension cable for digital sensors with Memosens protocol
- Product Configurator on the product page: [www.endress.com/cyk11](http://www.endress.com/cyk11)

 Technical Information TI00118C

#### Memosens laboratory cable CYK20

- For digital sensors with Memosens technology
- Product Configurator on the product page: [www.endress.com/cyk20](http://www.endress.com/cyk20)

### 11.1.3 Zero-point gel

#### COY8

Zero-point gel for oxygen and disinfection sensors

- Oxygen-free and chlorine-free gel for the verification, zero point calibration and adjustment of oxygen and disinfection measuring points
- Product Configurator on the product page: [www.endress.com/coy8](http://www.endress.com/coy8)

 Technical Information TI01244C

### 11.1.4 Transmitter

#### Liquiline CM44

- Modular multi-channel transmitter for hazardous and non-hazardous areas
- Hart®, PROFIBUS, Modbus or EtherNet/IP possible
- Order according to product structure

 Technical Information TI00444C

#### Liquiline CM42

- Modular two-wire transmitter for hazardous and non-hazardous areas
- Hart®, PROFIBUS or FOUNDATION Fieldbus possible
- Order according to product structure

 Technical Information TI00381C

#### Liquiline Mobile CML18

- Multiparameter mobile device for laboratory and field
- Reliable transmitter with display and app connection
- Product Configurator on the product page: [www.endress.com/CML18](http://www.endress.com/CML18)

 Operating Instructions BA02002C

#### Liquiline Compact CM82

- Configurable 1-channel multiparameter transmitter for Memosens sensors
- Ex- and non-ex applications possible in all industries
- Product Configurator on the product page: [www.endress.com/CM82](http://www.endress.com/CM82)

 Technical Information TI01397C

**Liquiline Compact CM72**

- 1-channel single parameter field device for Memosens sensors
- Ex- and non-ex applications possible in all industries
- Product Configurator on the product page: [www.endress.com/CM72](http://www.endress.com/CM72)



Technical Information TI01409C

**Memosens analog converter CYM17**

- Converter for Memosens sensors
- Enables the simple use of digital Memosens sensors in fermentation applications in the laboratory
- Product Configurator on the product page: [www.endress.com/cym17](http://www.endress.com/cym17)



Operating Instructions BA01833C

**Memobase Plus CYZ71D**

- PC software to support laboratory calibration
- Visualization and documentation of sensor management
- Sensor calibrations stored in database
- Product Configurator on the product page: [www.endress.com/cyz71d](http://www.endress.com/cyz71d)



Technical Information TI00502C

## 12 Technical data

### 12.1 Input

Measured variable	Dissolved oxygen [mg/l, µg/l, ppm, ppb or %SAT or hPa] Oxygen (gaseous) [hPa or %Vol] Temperature [°C, °F]
-------------------	--

Maximum measuring range Measuring ranges apply for 25 °C (77 °F) and 1013 hPa (15 psi)

c-shaped	u-shaped
0.004 to 26 mg/l 0.05 to 285 % SAT 0.1 to 600 hPa	0.004 to 30 mg/l 0.05 to 330 % SAT 0.1 to 700 hPa

 The sensor has an operational range up to 1000 hPa.  
The measured errors indicated are reached in the measuring range, but not over the entire operational range.

### 12.2 Performance characteristics

Response time	From air to nitrogen at reference operating conditions: <ul style="list-style-type: none"> <li>■ <math>t_{90}</math> : &lt; 10 s</li> <li>■ <math>t_{98}</math> : &lt; 20 s</li> </ul>
---------------	---

Reference operating conditions	Reference temperature: 25 °C (77 °F) Reference pressure: 1013 hPa (15 psi)
--------------------------------	---

Maximum measured error <sup>1)</sup>	±1 % or ±8 µg/l (ppb) of the measured value (the higher value is relevant in each case)				
	<table border="1"> <thead> <tr> <th>LOD (limit of detection)</th> <th>LOQ (limit of quantification)</th> </tr> </thead> <tbody> <tr> <td>4ppb</td> <td>10ppb</td> </tr> </tbody> </table>	LOD (limit of detection)	LOQ (limit of quantification)	4ppb	10ppb
LOD (limit of detection)	LOQ (limit of quantification)				
4ppb	10ppb				

Repeatability	2ppb
---------------	------

### 12.3 Environment

Ambient temperature range	-5 to +100 °C (23 to 212 °F)
---------------------------	------------------------------

Storage temperature range	-25 to 50 °C (77 to 120 °F) at 95% relative air humidity, non-condensing
---------------------------	---

1) In accordance with IEC 60746-1 at rated operating conditions

Degree of protection IP68  
IP69

## 12.4 Process

Process temperature range

Sensor	Min. and max. process temperature	Permanent process temperature
COS81E-****1* (EPDM)	-10 to +140 °C (15 to 280 °F)	
COS81E-****3* (FFKM)	0 to +140 °C (32 to 280 °F)	
COS81E-**C*** (c-shaped)		0 to 60 °C (32 to 140 °F)
COS81E-**U*** (u-shaped)		0 to 80 °C (32 to 175 °F)

Process pressure range 0.02 to 13 bar (0 to 190 psi) abs.

Temperature/pressure ratings

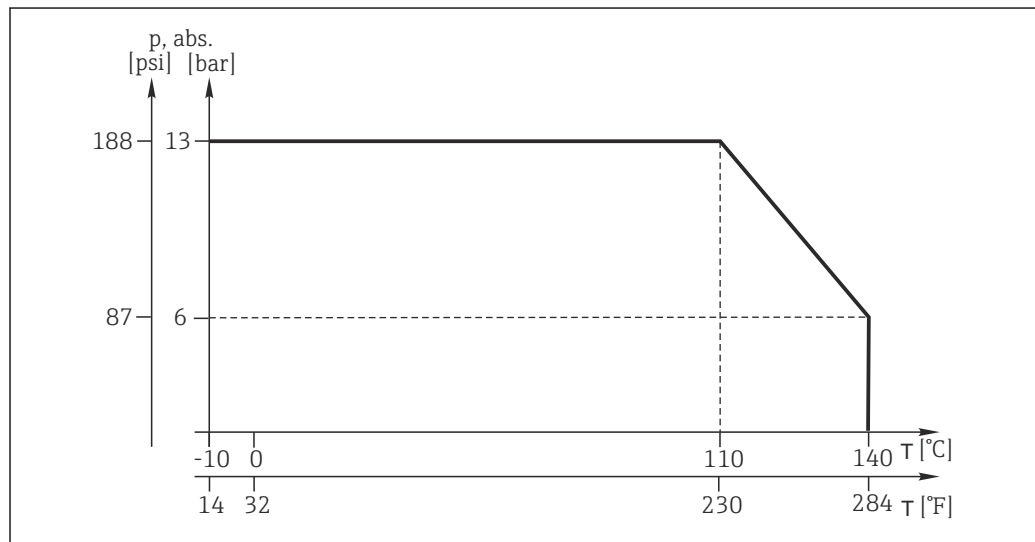

A0045731

Chemical resistance

**NOTICE**

**Halogen-containing solvents, ketones and toluene**

Halogen-containing solvents (dichloromethane, chloroform), ketones (e.g. acetone, pentanone) and toluene have a cross-sensitive effect and result in decreased measured values or, at worst, in the complete failure of the sensor!

- Use the sensor only in media that are free from halogens, ketones and toluene.

CIP compatibility Yes

Autoclavability Yes, max. 140 °C (284 °F)

## 12.5 Mechanical construction

Design

The sensor's spot cap can have either a c-shaped or u-shaped design.

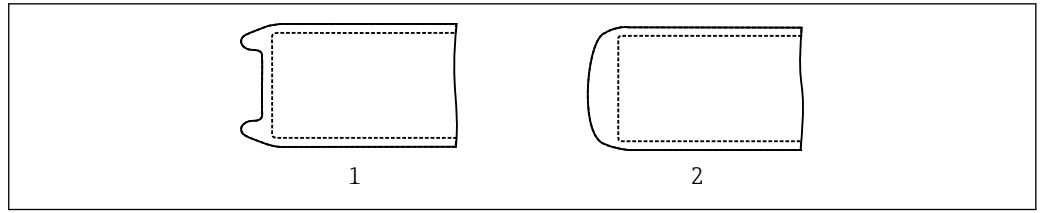

13 Design of spot cap

- 1 u-shaped
- 2 c-shaped

A0034733

Dimensions

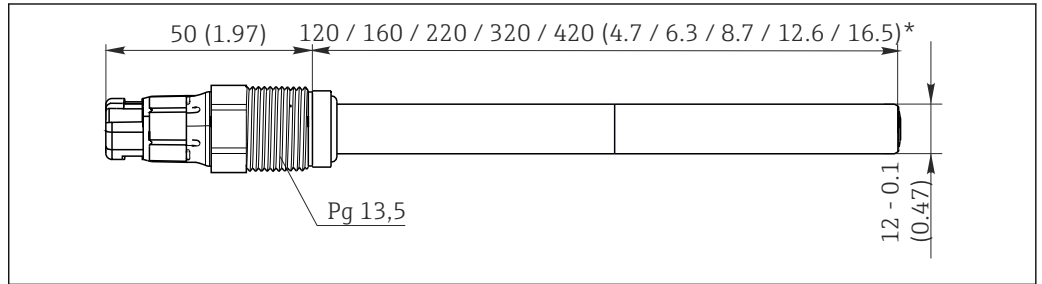

14 Dimensions in mm (inch)

A0043883

Optional flow assembly CYA21 for sensors with Ø 12 mm (accessories)

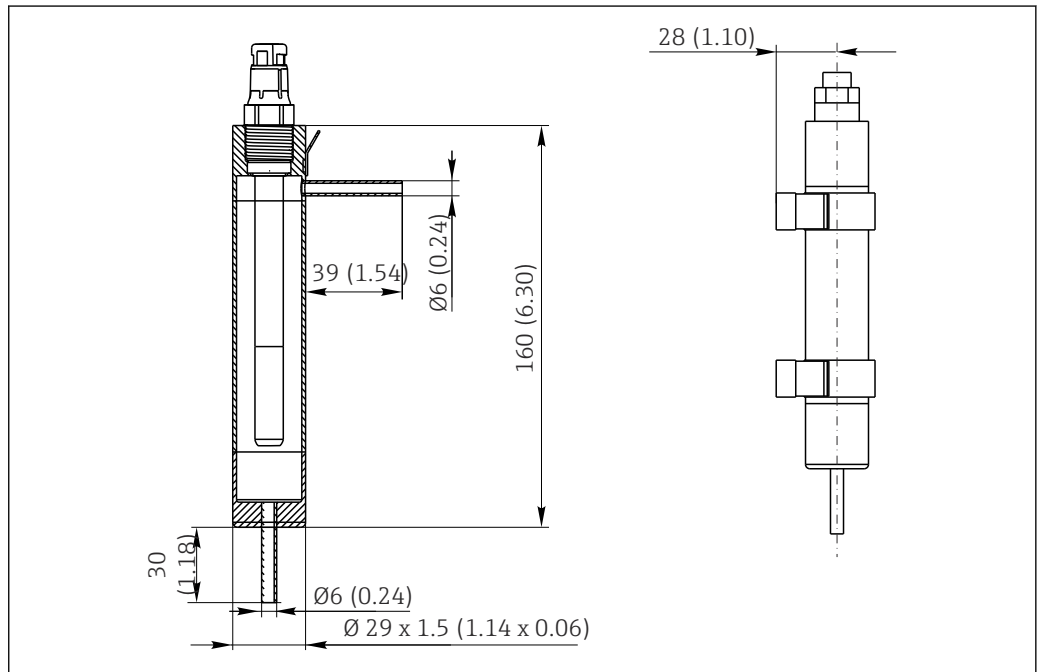

15 Dimensions in mm (inch)

A0043025

Weight

Depending on the design (length)  
 Example: 0.1 kg (0.20 lbs) for version with 120 mm length

Materials

Parts in contact with medium

Sensor shaft	Stainless steel 1.4435 (AISI 316L)
Process seal	FKM (USP<87>, <88> Class VI and FDA)
Process seal for Ex versions	FKM (not FDA-compliant)

---

Seals/O-rings	EPDM, FFKM (USP<87>, <88> Class VI and FDA)
Spot cap	Stainless steel 1.4435 (AISI 316L) or titanium or Hastelloy
Spot layer	Silicone (USP<87>, <88> Class VI and FDA)

---

Process connection	Pg 13.5 Torque max. 3 Nm
--------------------	-----------------------------

---

Surface roughness	$R_a < 0.38 \mu\text{m}$
-------------------	--------------------------

---

Temperature sensor	Pt1000 (Class A according to DIN IEC 60751)
--------------------	---











[www.addresses.endress.com](http://www.addresses.endress.com)

---