

Operating Instructions

Memosens COS22E

Amperometric oxygen sensor with Memosens 2.0 technology





Table of contents







1	About this document	4	10	Repair	26
1.1	Warnings	4	10.1	General notes	26
1.2	Symbols used	4	10.2	Return	26
1.3	Supplementary documentation	5	10.3	Spare parts and consumables	26
2	Basic safety instructions	6	10.4	Checking the measurement function	33
2.1	Requirements for the personnel	6	10.5	Disposal	34
2.2	Intended use	6	11	Accessories	35
2.3	Workplace safety	6	11.1	Device-specific accessories	35
2.4	Operational safety	7	12	Technical data	38
2.5	Product safety	7	12.1	Input	38
3	Product description	8	12.2	Power supply	38
3.1	Product design	8	12.3	Performance characteristics	38
3.2	Measuring principle	8	12.4	Environment	40
3.3	Membrane body	8	12.5	Process	41
3.4	Polarization	8	12.6	Mechanical construction	42
3.5	Memosens technology	9	Index	44	
4	Incoming acceptance and product identification	10			
4.1	Incoming acceptance	10			
4.2	Product identification	10			
4.3	Scope of delivery	11			
5	Mounting	12			
5.1	Mounting requirements	12			
5.2	Mounting the sensor	13			
5.3	Installation examples	14			
5.4	Post-mounting check	16			
6	Electrical connection	17			
6.1	Connecting the sensor	17			
6.2	Ensuring the degree of protection	17			
6.3	Post-connection check	17			
7	Commissioning	18			
7.1	Function check	18			
7.2	Sensor polarization and preparation for calibration/adjustment	18			
7.3	Calibration and adjustment	19			
8	Diagnostics and troubleshooting ...	23			
8.1	General troubleshooting	23			
9	Maintenance	24			
9.1	Maintenance schedule	24			
9.2	Maintenance tasks	24			

1 About this document



1.1 Warnings

Structure of information	Meaning
 DANGER Causes (/consequences) If necessary, Consequences of non-compliance (if applicable) ▶ Corrective action	This symbol alerts you to a dangerous situation. Failure to avoid the dangerous situation will result in a fatal or serious injury.
 WARNING Causes (/consequences) If necessary, Consequences of non-compliance (if applicable) ▶ Corrective action	This symbol alerts you to a dangerous situation. Failure to avoid the dangerous situation can result in a fatal or serious injury.
 CAUTION Causes (/consequences) If necessary, Consequences of non-compliance (if applicable) ▶ Corrective action	This symbol alerts you to a dangerous situation. Failure to avoid this situation can result in minor or more serious injuries.
NOTICE Cause/situation If necessary, Consequences of non-compliance (if applicable) ▶ Action/note	This symbol alerts you to situations which may result in damage to property.

1.2 Symbols used

Symbol	Meaning
	Additional information, tips
	Permitted or recommended
	Not permitted or not recommended
	Reference to device documentation
	Reference to page
	Reference to graphic
	Result of a step

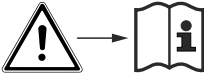
1.2.1 Symbols on the device

Symbol	Meaning
	Reference to device documentation
	Do not dispose of products bearing this marking as unsorted municipal waste. Instead, return them to the manufacturer for disposal under the applicable conditions.

1.3 Supplementary documentation

The following manuals which complement these Operating Instructions can be found on the product pages on the Internet:

- Technical Information for the relevant sensor
- Operating Instructions for the transmitter used
- Operating Instructions for the cable used
- Safety data sheet for the relevant electrolyte solutions

In addition to these Operating Instructions, an XA with "Safety instructions for electrical apparatus in the hazardous area" is also included with sensors for use in the hazardous area.

- ▶ Please follow instructions on use in the hazardous area carefully.

Devices in hygienic applications place specific demands on the installation. These must be taken into account in order to guarantee hygienic operation without contamination of the process medium. These requirements can be found in the "Special Documentation: Hygienic Applications" SD02751C on the product pages on the Internet.

2 Basic safety instructions

2.1 Requirements for the personnel

- Installation, commissioning, operation and maintenance of the measuring system may be carried out only by specially trained technical personnel.
- The technical personnel must be authorized by the plant operator to carry out the specified activities.
- The electrical connection may be performed only by an electrical technician.
- The technical personnel must have read and understood these Operating Instructions and must follow the instructions contained therein.
- Faults at the measuring point may only be rectified by authorized and specially trained personnel.

 Repairs not described in the Operating Instructions provided must be carried out only directly at the manufacturer's site or by the service organization.

2.2 Intended use

The sensor is suitable for continuous measurement of dissolved oxygen in aqueous solutions.

The specific suitability depends on the sensor design:

- COS22E-**12/22** (standard sensor, maximum measuring range 0.01 to 60 mg/l, preferred measuring range 0.01 to 20 mg/l)
 - Measuring, monitoring and regulating the oxygen content in fermenters
 - Monitoring the oxygen content in biotechnology facilities
- COS22E-**12** (trace sensor, measuring range 0 to 10 mg/l, preferred measuring range 0.001 to 2 mg/l), also suitable for high CO₂ partial pressure
 - Monitoring the residual oxygen content in carbonated fluids of the beverage industry
 - Monitoring the residual oxygen content in boiler feedwater
 - Monitoring, measuring and regulating the oxygen content in chemical processes
 - Trace measurement in industrial applications, e.g. inertization

NOTICE

Molecular hydrogen

Hydrogen has a cross-sensitive effect and results in lower readings than expected or, at worst, total failure of the sensor.

- ▶ Only use the COS22E-**12/22** sensor in hydrogen-free media.
- ▶ A modified version of the sensor is available for applications in media containing hydrogen.
- ▶ Contact the Endress+Hauser sales team for further information.

The COS22E sensor must be connected to measuring cable CYK10 or CYK20 for non-contact, digital data transmission to the digital input of a Liquiline transmitter.

Use of the device for any purpose other than that described, poses a threat to the safety of people and of the entire measuring system and is therefore not permitted.

The manufacturer is not liable for damage caused by improper or non-designated use.

2.3 Workplace safety

As the user, you are responsible for complying with the following safety conditions:

- Installation guidelines
- Local standards and regulations
- Regulations for explosion protection

Electromagnetic compatibility

- The product has been tested for electromagnetic compatibility in accordance with the applicable international standards for industrial applications.
- The electromagnetic compatibility indicated applies only to a product that has been connected in accordance with these Operating Instructions.

2.4 Operational safety

Before commissioning the entire measuring point:

1. Verify that all connections are correct.
2. Ensure that electrical cables and hose connections are undamaged.
3. Do not operate damaged products, and protect them against unintentional operation.
4. Label damaged products as defective.

During operation:

- ▶ If faults cannot be rectified:
products must be taken out of service and protected against unintentional operation.

2.5 Product safety

2.5.1 State-of-the-art technology

The product is designed to meet state-of-the-art safety requirements, has been tested, and left the factory in a condition in which it is safe to operate. The relevant regulations and international standards have been observed.

3 Product description

3.1 Product design

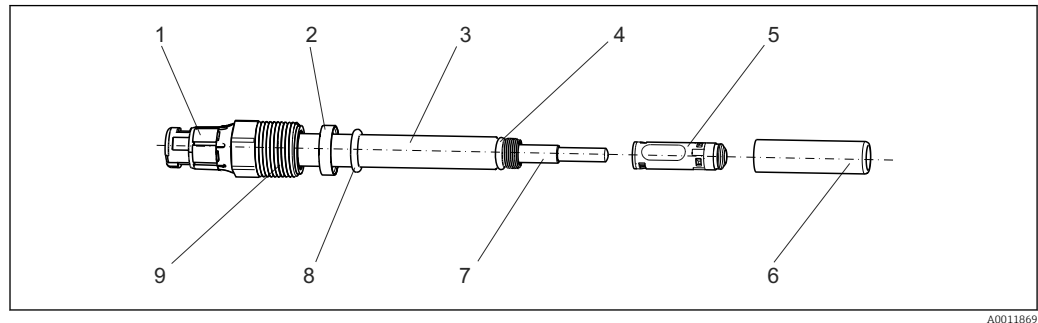

☑ 1	COS22E		
1	Plug-in head	4	O-ring 8.5 x 1.5 mm
2	Thrust collar	5	Membrane body
3	Sensor shaft	6	Shaft sleeve
		7	Internal body with working electrode and counter-electrode
		8	Process seal 10.77 x 2.62 mm
		9	Process connection Pg 13.5

3.2 Measuring principle

3.2.1 Amperometric measuring principle

During amperometric oxygen measurement, oxygen molecules diffuse through the membrane and are reduced to hydroxide ions (OH⁻) at the working electrode. At the counter-electrode, silver is oxidized to silver ions (Ag⁺) (this forms a silver halide layer). The associated release of electrons at the working electrode and absorption of electrons at the counter-electrode causes a current to flow. Under constant conditions, this current flow is proportional to the oxygen content of the medium. The current is converted in the transmitter and indicated on the display as an oxygen concentration in mg/l, µg/l, ppm, ppb or Vol%, ppmVol, raw value nA, as a saturation index in % SAT or as an oxygen partial pressure in hPa.

3.3 Membrane body

The oxygen dissolved in the medium is transported to the membrane by the necessary flow. The membrane is permeable for dissolved gases only. Other substances dissolved in the liquid phase, e.g. ionic substances, will not penetrate through the membrane. Therefore, medium conductivity has no impact on the measuring signal.

The sensor is shipped with a membrane body, which can be used for both measuring ranges. The membrane is pretensioned at the factory and can be used immediately.

i Electrolytes are measuring range-specific and **cannot** be mixed in a single application!

Also pay attention to the safety datasheet of the electrolyte
www.endress.com/downloads.

3.4 Polarization

When the sensor is connected to the transmitter, a fixed voltage is applied between the working electrode and the counter-electrode. The resulting polarization current can be identified on the transmitter by a reading that is initially high, but decreases over time. The reading must be stable before the sensor can be calibrated and a reliable measurement is possible.

Reference value for almost complete sensor polarization:

- COS22E-**22****:
2 hours
- COS22E-**12****:
12 hours

3.5 Memosens technology

Sensors with Memosens protocol have an integrated electronics unit that stores calibration data and other information. Once the sensor has been connected, the sensor data are transferred automatically to the transmitter and used to calculate the measured value and for Heartbeat Technology functions.

- ▶ Call up the sensor data via the corresponding DIAG menu.

Digital sensors can store measuring system data (among other types of data) in the sensor:

- Manufacturer data
- Serial number
- Order code
- Date of manufacture
- Digital sensor label
- Calibration data of the last eight calibrations including factory calibration with calibration date and calibration values
- Serial number of the transmitter used to perform the last calibration
- Possibility to reset to factory calibration
- In the case of sensors with replaceable measuring elements, the number of calibrations per measuring element and for the entire sensor
- Operating data
- Temperature application range
- Date of initial commissioning
- Hours of operation under extreme conditions
- Number of sterilizations and CIP cycles (with hygienic sensors)

All Memosens 2.0 E sensors offer these advantages with the latest Liquiline transmitter software. All Memosens 2.0 sensors are backward compatible with previous software versions and offer the usual Memosens benefits of the D generation.

4 Incoming acceptance and product identification

4.1 Incoming acceptance

1. Verify that the packaging is undamaged.
 - ↳ Notify the supplier of any damage to the packaging.
Keep the damaged packaging until the issue has been resolved.
2. Verify that the contents are undamaged.
 - ↳ Notify the supplier of any damage to the delivery contents.
Keep the damaged goods until the issue has been resolved.
3. Check that the delivery is complete and nothing is missing.
 - ↳ Compare the shipping documents with your order.
4. Pack the product for storage and transportation in such a way that it is protected against impact and moisture.
 - ↳ The original packaging offers the best protection.
Make sure to comply with the permitted ambient conditions.

If you have any questions, please contact your supplier or your local Sales Center.

4.2 Product identification

4.2.1 Nameplate

The nameplate provides you with the following information on your device:

- Manufacturer identification
 - Order code
 - Extended order code
 - Serial number
 - Safety information and warnings
 - Certificate information
- ▶ Compare the information on the nameplate with the order.

4.2.2 Product identification

Product page

www.endress.com/cos22e

Interpreting the order code

The order code and serial number of your product can be found in the following locations:

- On the nameplate
- In the delivery papers
- As a DMC on the Memosens plug-in head (can be read via the E+H Operations App)

Obtaining information on the product

1. Open www.endress.com.
2. Call up the site search (magnifying glass).
3. Enter a valid serial number.
4. Search.
 - ↳ The product structure is displayed in a popup window.

5. Click on the product image in the popup window.
 - ↳ A new window (**Device Viewer**) opens. All of the information relating to your device is displayed in this window as well as the product documentation.

4.2.3 Manufacturer address

Endress+Hauser Conducta GmbH+Co. KG
Dieselstraße 24
D-70839 Gerlingen

4.3 Scope of delivery

The scope of delivery comprises:

- Ordered version of the sensor with protection cap (filled with tap water) to protect the membrane
- Electrolyte, 1 bottle, 10 ml (0.34 fl.oz.)
- Tool to push out the membrane body
- Optional certificates that have been ordered
- Safety instructions for the hazardous area (for sensors with Ex approval)
- Brief Operating Instructions

5 Mounting

5.1 Mounting requirements

5.1.1 Dimensions

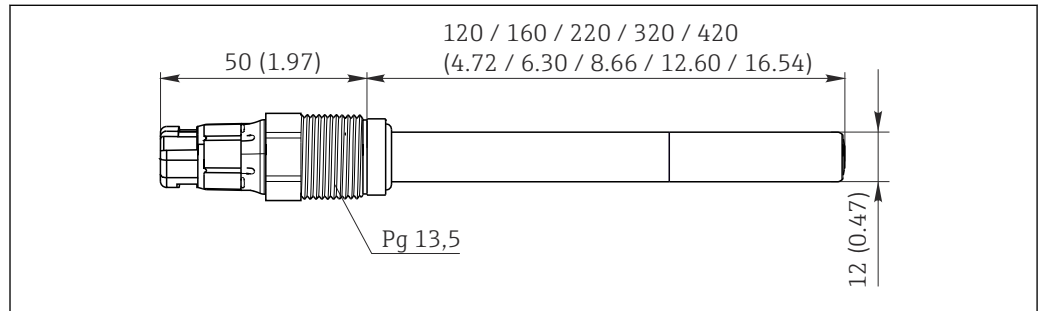

2 Dimensions in mm (inch)

5.1.2 Orientation

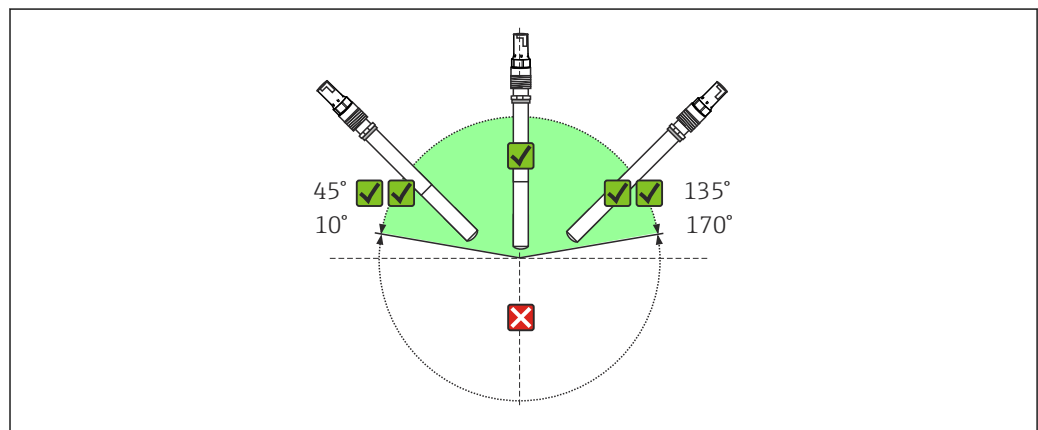

3 Permitted orientations

✓✓ Recommended installation angle

✓ Possible installation angle

✗ Inadmissible installation angle

The sensor must be installed at an angle of inclination of 10° to 170° in an assembly, holder or suitable process connection. Recommended angle: 45° to prevent the attachment of air bubbles.

Inclination angles other than those mentioned are not permitted. Do **not** install the sensor upside down.

 Follow the instructions for installing sensors in the Operating Instructions for the assembly used.

5.1.3 Mounting location

1. Choose a mounting location that is easy to access.
2. Ensure that upright posts and assemblies are fully secured and vibration-free.

3. Choose a mounting location with an oxygen concentration that is typical for the application.

5.1.4 Hygienic requirements

The use of an EHEDG-certified assembly is a prerequisite for the easy-to-clean installation of a 12-mm sensor in accordance with EHEDG requirements.

Furthermore, the instructions regarding the hygienic installation and operation of the assembly in the relevant Operating Instructions must be adhered to.

The Special Documentation for hygienic applications must be observed for hygienic operation.

5.2 Mounting the sensor

5.2.1 Measuring system

A complete measuring system comprises:

- a Memosens COS22E oxygen sensor
- A transmitter, e.g. Liquiline CM42
- Optional: an assembly, e.g. Unifit CPA842 fixed installation assembly, Flowfit CYA21 flow assembly or Cleanfit CPA875 retractable assembly

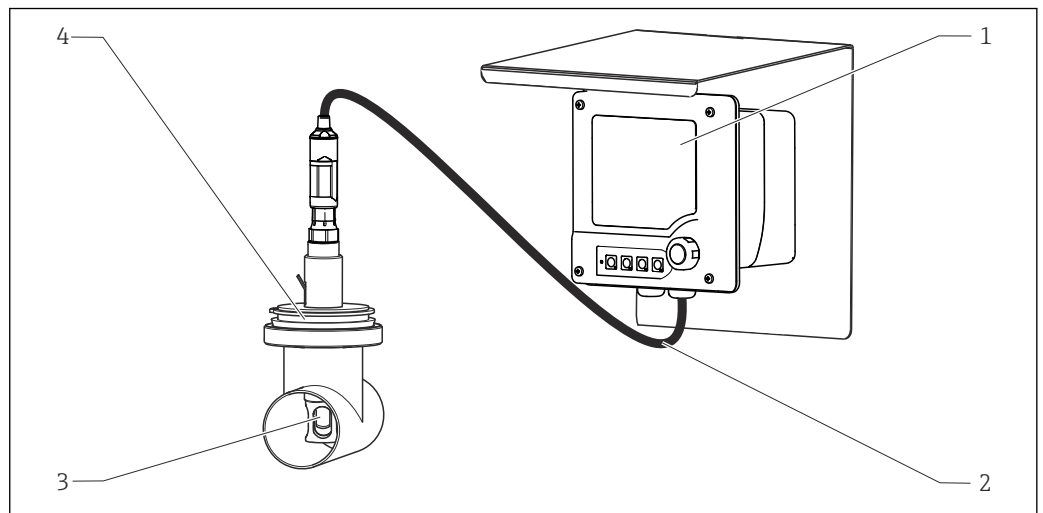

4 Example of a measuring system with Memosens COS22E

- 1 Liquiline CM42
- 2 Measuring cable CYK10
- 3 Oxygen sensor Memosens COS22E
- 4 Permanent installation assembly CPA842

5.2.2 Installing at a measuring point

Must be installed in a suitable assembly (depending on the application).

⚠ WARNING

Electrical voltage

In the event of a fault, non-grounded metallic assemblies may be live and as such are not safe to touch!

- ▶ When using metallic assemblies and installation equipment, national grounding provisions must be observed.

To fully install a measuring point proceed in accordance with the following steps:

1. Install the retractable or flow assembly (if used) in the process.
2. Install the oxygen sensor in the assembly
3. Connect the cable to the sensor and transmitter
4. Supply power to the transmitter

NOTICE

Installation fault

Cable open circuit, loss of sensor due to cable separation, unscrewing of membrane cap in the assembly!

- ▶ Do not install the sensor freely suspended from the cable!
- ▶ Hold the sensor body steady during installation or removal. Turn **only the hexagonal nut** on the Pg coupling. Otherwise, the membrane cap may become unscrewed and will then remain in the assembly or process.
- ▶ Avoid exerting excessive tensile force on the cable (e.g. through jerky pulling movements).
- ▶ Choose a mounting location that is easy to access for later calibrations.
- ▶ Follow the instructions for installing sensors in the Operating Instructions for the assembly used.

5.3 Installation examples

5.3.1 Permanent installation assembly Unifit CPA842

The permanent installation assembly CPA842 enables easy adaptation of a sensor to nearly any process connections from Ingold nozzles to Varivent or Tri-Clamp connections. This kind of installation is very well suited for tanks and larger pipes. This enables a defined immersion depth of the sensor into the medium in the simplest way.

5.3.2 Flow assembly Flowfit CPA240

The Flowfit CPA240 flow assembly offers up to three mounting slots for sensors with a shaft diameter of 12 mm (0.47"), a shaft length of 120 mm (4.7") and a Pg 13.5 process connection. It very well suited for use in pipelines or hose connections. To prevent measured error with trace measurements, pay particular attention to complete ventilation of the assembly.

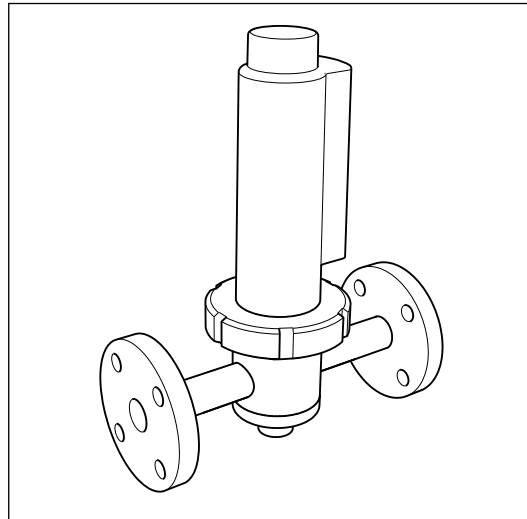

A0005720

5 Flowfit CPA240 flow assembly with protection cover

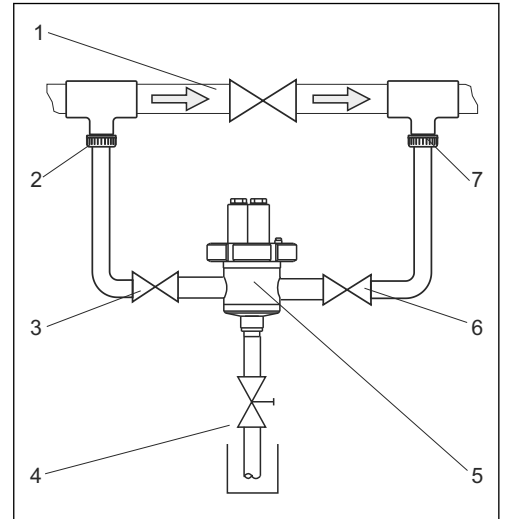

A0005721

6 Bypass installation

- 1 Main pipe
- 2 Medium removal
- 3, 6 Manually actuated or solenoid valves
- 4 Sampling
- 5 Flow assembly with installed sensor
- 7 Medium return

5.3.3 Flow assembly Flowfit CYA21 for water treatment and processes

The compact stainless steel assembly offers space for a 12 mm sensor with a length of 120 mm. The assembly has a low sampling volume and, with the 6-mm connections, it is best suited for residual oxygen measurement in water treatments and boiler feedwater. The flow comes from below.

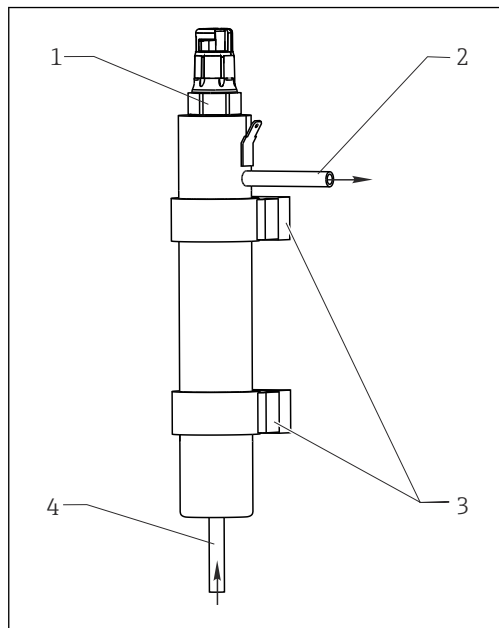

A0014081

7 Flow assembly CYA21

- 1 Installed Memosens COS22E sensor
- 2 Drain
- 3 Wall mount (clamp D29)
- 4 Inflow

5.3.4 Retractable assembly Cleanfit CPA871 or Cleanfit CPA875

The assembly is designed for installation on vessels and pipes. This requires the availability of suitable process connections.

Install the assembly in a place with uniform flow conditions. The pipe diameter must be at least DN 80.

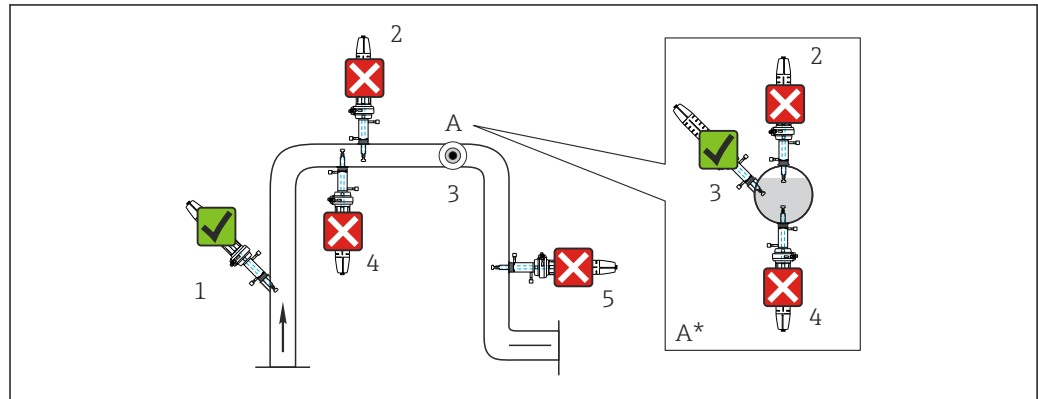

8 Suitable and unsuitable installation positions for Memosens COS22E

- 1 Ascending pipe, best position
- 2 Horizontal pipe, sensor top down, impermissible due to air cushion or foam bubble forming
- 3 Horizontal pipe, lateral installation, with suitable installation angle
- 4 Upside-down installation, unsuitable
- 5 Down pipe, impermissible
- A Detail A (top view)
- A* Detail A, turned by 90° (side view)
- ✓ Possible installation angle
- ✗ Inadmissible installation angle

NOTICE

Sensor not fully immersed in the medium, buildup, upside-down installation

These can all cause incorrect measurements!

- ▶ Do not install assembly at points where air pockets or bubbles may form.
- ▶ Avoid buildup on the sensor membrane or remove it at regular intervals.
- ▶ Do not install sensor upside down.

5.4 Post-mounting check

1. Are the sensor and cable undamaged?
2. Is the orientation correct?
3. Is the sensor installed in an assembly and is not suspended from the cable?
4. Avoid the penetration of moisture.

6 Electrical connection

⚠ WARNING

Device is live!

Incorrect connection may result in injury or death!

- ▶ The electrical connection may be performed only by an electrical technician.
- ▶ The electrical technician must have read and understood these Operating Instructions and must follow the instructions contained therein.
- ▶ **Prior** to commencing connection work, ensure that no voltage is present on any cable.

6.1 Connecting the sensor

The electrical connection of the sensor to the transmitter is established using the measuring cable CYK10.

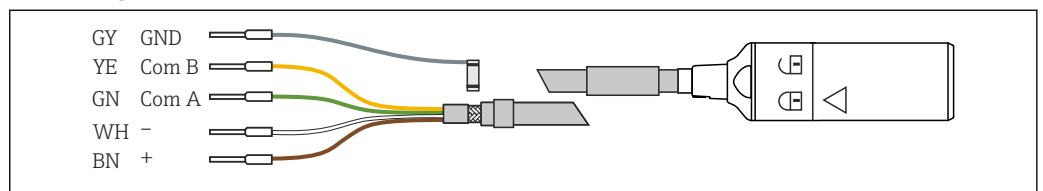

9 Measuring cable CYK10

6.2 Ensuring the degree of protection

Only the mechanical and electrical connections which are described in these instructions and which are necessary for the required, designated use, may be carried out on the device delivered.

- ▶ Exercise care when carrying out the work.

Otherwise, the individual types of protection (Ingress Protection (IP), electrical safety, EMC interference immunity) agreed for this product can no longer be guaranteed due, for example to covers being left off or cable (ends) that are loose or insufficiently secured.

6.3 Post-connection check

Device health and specifications	Action
Is the outside of the sensor, assembly or cable free from damage?	▶ Perform a visual inspection.
Electrical connection	Action
Are the mounted cables strain-relieved and not twisted?	▶ Perform a visual inspection. ▶ Untwist the cables.
Is a sufficient length of the cable cores stripped, and are the cores positioned in the terminal correctly?	▶ Perform a visual inspection. ▶ Pull gently to check they are seated correctly.
Are all screw terminals tightened?	▶ Tighten the screw terminals.
Are all cable entries mounted, firmly tightened and leak-tight?	▶ Perform a visual inspection.
Are all cable entries mounted on the side or pointing downwards?	In the case of lateral cable entries: ▶ Point cable loops downward so that water can drip off.

7 Commissioning

7.1 Function check

Prior to initial commissioning, ensure that:

- Is the sensor correctly installed?
- Is the electrical connection correct?

If using an assembly with automatic cleaning function:

- ▶ Check that the cleaning medium (water or air, for example) is connected correctly.

WARNING

Escaping process medium

Risk of injury from high pressure, high temperatures or chemical hazards!

- ▶ Before applying pressure to an assembly with cleaning system, ensure that the system has been connected correctly.
- ▶ If you cannot reliably establish the correct connection, do not install the assembly in the process.

1. At the transmitter, enter all the settings specific to the parameters and measuring point. These include the air pressure during calibration and measurement or the salinity, for instance.

2. Check whether a calibration/adjustment is necessary. (→  19)

The oxygen measuring point is then ready to measure.

 After commissioning, maintain the sensor at regular intervals to ensure reliable measurement.

 Operating Instructions for the transmitter used, such as BA01245C if using the Liquiline CM44x or Liquiline CM44xR.

7.2 Sensor polarization and preparation for calibration/adjustment

NOTICE

Incorrect measurements due to ambient influences!

- ▶ It is essential to avoid strong sunlight and drafts on the sensor.
- ▶ Comply with the instructions for commissioning in the Operating Instructions of the transmitter used.

The sensor has been tested at the factory to ensure it is functioning correctly and is delivered ready for operation.

To prepare for measuring and/or calibration:

1. Remove the sensor protective cap.
2. Expose the sensor, which is dry on the outside, to the air atmosphere.
 - ↳ The air should be saturated with water vapor. Therefore, install the sensor as close as possible to a water surface. However, the sensor membrane must remain dry during calibration. Therefore, avoid direct contact with the water surface.
3. Connect the sensor to the transmitter.
4. Switch on the transmitter.
 - ↳ When the sensor is connected to the transmitter, polarization takes place automatically once the transmitter has been switched on.
5. Wait for the polarization time to elapse .

Sensor	Polarization time
COS22E-**22**** (standard sensor):	< 30 min for 98% signal value, 2 h for 100%
COS22E-**12**** (trace sensor):	< 3 h for 98% signal value, 12 h for 100%

7.3 Calibration and adjustment

During calibration, the measured value is compared to the value expected under specified conditions (depending on the calibration method, e.g. in air with 100% rh at sea level).

Calibration of the sensor is essential after the following activities:

- Initial commissioning
- Replacement of membrane or electrolyte
- Replacement of internal body
- Longer breaks in operation without power supply

Calibration can also be monitored or renewed cyclically (at typical time intervals, depending on operating experience), e.g. within the context of system monitoring.

Fully polarize the sensor prior to calibration.

7.3.1 Types of calibration

A slope or zero point calibration can be carried out for the sensor.

In most applications, single-point calibration in the presence of oxygen is sufficient (=calibration of the sensor slope). When changing from process to calibration conditions, a longer polarization time and an adjustment of the temperature to the environment must be taken into account with the sensor.

The additional calibration of the zero point improves the accuracy of the measurement results at trace concentrations. Zero point calibration, e.g. with nitrogen (min. 99.995%) or COY8 zero-point gel. To prevent incorrect measurements in the trace range later on, make sure that the sensor is polarized and the measured value has settled at the zero point (this takes at least 30 minutes) →  19.

The following describes calibration of the slope in air (saturated with water vapor) as the easiest and recommended calibration method. However, this type of calibration is possible only if the air temperature is $\geq 0\text{ °C}$ (32 °F).

Before calibration, enter the air pressure/process pressure at the transmitter.

7.3.2 Zero point calibration

The zero point is not so important when working with relatively high concentrations of oxygen.

However, once oxygen sensors are used at low concentrations and in the trace range, they must also be calibrated at the zero point.

Zero point calibrations are demanding as the ambient medium - usually air - already has a high oxygen content. This oxygen must be excluded for zero point calibration of the sensor.

A calibration with the COY8 zero-point gel can be used for this purpose:

The COY8 oxygen-depleting gel creates an oxygen-free medium for zero point calibration.

Prior to sensor zero point calibration, check the following:

- Is the sensor signal stable?
- Is the value displayed plausible?

1. If the sensor signal is stable:
Calibrate the zero point.

2. If necessary:
Adjust the sensor by accepting the calibration data.

The reference method (sample calibration in zero point) can also be used here if appropriate collecting vessels or reference measurement are available.

 If the oxygen sensor is calibrated too early, this can result in an incorrect zero point.

Rule of thumb: operate the sensor for at least 30 min in the zero-point gel.

If the sensor was already operated in the trace range before the zero point calibration, the time specified above generally suffices. If the sensor was operated in air, significantly more time must be factored in to also remove residual oxygen from any dead volume inherent to the design. Here a value of 2 hours applies as a general rule.

 Follow the instructions in the kit documentation enclosed with the COY8 zero-point gel.

7.3.3 Calibration in air with 100% rH

1. Remove the sensor from the medium.
 2. Clean the outside of the sensor carefully with a damp cloth.
 3. Allow a temperature compensation time of approx. 20 minutes for the sensor in the ambient air. Make sure that the sensor is not exposed to any direct ambient effects (direct sunlight, drafts) during this time.
 4. Is the measured value display on the transmitter stable:
Perform the calibration in accordance with the Operating Instructions for the transmitter. Pay particular attention to the software settings for the stability criteria for calibration and for the ambient pressure.
 5. Where necessary:
Adjust the sensor by accepting the calibration data.
 6. Then place the sensor back into the medium.
 7. Deactivate the hold status at the transmitter.
- Follow the calibration instructions in the Operating Instructions for the transmitter used.

7.3.4 Calculation example for the calibration value

As a check, you can calculate the expected calibration value (transmitter display) as shown in the following example (salinity is 0).

1. Determine the following:
 - Ambient temperature for the sensor (air temperature for **Air 100% rh** or **Air variable** calibration types, water temperature for **H2O air-saturated** calibration type)
 - The altitude above sea level
 - The current air pressure (= relative air pressure based on sea level) at the time of calibration. (If indeterminable, use 1013 hPa.)
2. Determine the following:
 - The saturation value S acc. to Table 1
 - The altitude factor K acc. to Table 2

Table 1

T [°C (°F)]	S [mg/l=ppm]	T [°C (°F)]	S [mg/l=ppm]	T [°C (°F)]	S [mg/l=ppm]	T [°C (°F)]	S [mg/l=ppm]
0 (32)	14.64	11 (52)	10.99	21 (70)	8.90	31 (88)	7.42
1 (34)	14.23	12 (54)	10.75	22 (72)	8.73	32 (90)	7.30
2 (36)	13.83	13 (55)	10.51	23 (73)	8.57	33 (91)	7.18
3 (37)	13.45	14 (57)	10.28	24 (75)	8.41	34 (93)	7.06
4 (39)	13.09	15 (59)	10.06	25 (77)	8.25	35 (95)	6.94
5 (41)	12.75	16 (61)	9.85	26 (79)	8.11	36 (97)	6.83
6 (43)	12.42	17 (63)	9.64	27 (81)	7.96	37 (99)	6.72
7 (45)	12.11	18 (64)	9.45	28 (82)	7.82	38 (100)	6.61
8 (46)	11.81	19 (66)	9.26	29 (84)	7.69	39 (102)	6.51
9 (48)	11.53	20 (68)	9.08	30 (86)	7.55	40 (104)	6.41
10 (50)	11.25						

Table 2

Height [m (ft)]	K	Height [m (ft)]	K	Height [m (ft)]	K	Height [m (ft)]	K
0 (0)	1.000	550 (1800)	0.938	1050 (3450)	0.885	1550 (5090)	0.834
50 (160)	0.994	600 (1980)	0.932	1100 (3610)	0.879	1600 (5250)	0.830
100 (330)	0.988	650 (2130)	0.927	1150 (3770)	0.874	1650 (5410)	0.825
150 (490)	0.982	700 (2300)	0.922	1200 (3940)	0.869	1700 (5580)	0.820
200 (660)	0.977	750 (2460)	0.916	1250 (4100)	0.864	1750 (5740)	0.815
250 (820)	0.971	800 (2620)	0.911	1300 (4270)	0.859	1800 (5910)	0.810
300 (980)	0.966	850 (2790)	0.905	1350 (4430)	0.854	1850 (6070)	0.805
350 (1150)	0.960	900 (2950)	0.900	1400 (4600)	0.849	1900 (6230)	0.801
400 (1320)	0.954	950 (3120)	0.895	1450 (4760)	0.844	1950 (6400)	0.796
450 (1480)	0.949	1000 (3300)	0.890	1500 (4920)	0.839	2000 (6560)	0.792
500 (1650)	0.943						

3. Calculate factor L:

$$L = \frac{\text{Relative air pressure at calibration}}{1013 \text{ hPa}}$$

4. Determine the M factor:

- M = 1.02 (for Air 100% rh calibration type)
- M = 1.00 (for H2O air-saturated calibration type)

5. Calculate calibration value C:

$$C = S \cdot K \cdot L \cdot M$$

Example

- Air calibration at 18 °C (64 °F), altitude 500 m (1650 ft) above sea level, current air pressure 1009 hPa
- $S = 9.45 \text{ mg/l}$, $K = 0.943$, $L = 0.996$, $M=1.02$
- Calibration value $C = 9.05 \text{ mg/l}$.

i Factor K in the table is not required if the measuring device returns the absolute air pressure L_{abs} (air pressure depending on altitude) as the measured value. The formula for calculation is then: $C = S \cdot L_{\text{abs}}$.

8 Diagnostics and troubleshooting

8.1 General troubleshooting

- ▶ If one of the following problems is present:
Check the measuring system in the order shown.

Problem	Test	Remedial action
No reading, sensor not responding	Power supplied to the transmitter?	<ul style="list-style-type: none"> ▶ Establish the power supply. ▶ Switch on channel on transmitter.
	Sensor cable connected correctly?	<ul style="list-style-type: none"> ▶ Establish correct connection.
	Insufficient medium flow?	<ul style="list-style-type: none"> ▶ Create medium flow.
	No electrolyte in the measuring chamber?	<ul style="list-style-type: none"> ▶ Refill or replace electrolyte.
	Buildup on the membrane cap?	<ul style="list-style-type: none"> ▶ Clean sensor carefully.
Displayed value too high	Polarization ended?	<ul style="list-style-type: none"> ▶ Wait for polarization time to elapse
	Is sensor calibrated/adjusted?	<ul style="list-style-type: none"> ▶ Recalibrate/readjust. <ul style="list-style-type: none"> ↳ When calibrating, enter the current air pressure at the transmitter.
	Displayed temperature clearly too low?	<ul style="list-style-type: none"> ▶ Test sensor, if necessary contact the Endress+Hauser sales team.
	Membrane visibly stretched?	<ul style="list-style-type: none"> ▶ Replace membrane cap.
	Is electrolyte contaminated?	<ul style="list-style-type: none"> ▶ Replace electrolyte.
	Deposit buildup on the cathode?	<ul style="list-style-type: none"> ▶ Clean the cathode.
	Internal body defective?	<ul style="list-style-type: none"> ▶ Change the internal body.
Displayed value too low	Polarization ended?	<ul style="list-style-type: none"> ▶ Wait for polarization time to elapse
	Is sensor calibrated/adjusted?	<ul style="list-style-type: none"> ▶ Recalibrate/readjust. <ul style="list-style-type: none"> ↳ When calibrating, enter the current air pressure at the transmitter.
	Insufficient medium flow?	<ul style="list-style-type: none"> ▶ Create medium flow.
	Displayed temperature clearly too high?	<ul style="list-style-type: none"> ▶ Test sensor, if necessary contact the Endress+Hauser sales team.
	Is electrolyte contaminated?	<ul style="list-style-type: none"> ▶ Replace electrolyte.
	Is membrane coated?	<ul style="list-style-type: none"> ▶ Clean sensor carefully.
Display value fluctuating	Membrane visibly stretched?	<ul style="list-style-type: none"> ▶ Replace membrane cap.

-  Follow the troubleshooting instructions in the Operating Instructions for the transmitter. Check the transmitter if necessary.

9 Maintenance

Take all the necessary precautions in time to ensure the operational safety and reliability of the entire measuring system.

NOTICE

Effects on process and process control!

- ▶ When carrying out any work on the system, bear in mind any potential impact this could have on the process control system and the process itself.
- ▶ For your own safety, only use genuine accessories. With genuine parts, the function, accuracy and reliability are also ensured after maintenance work.

9.1 Maintenance schedule

Maintenance cycles depend to a great extent on the operating conditions.

The following rule of thumb applies:

- Constant conditions, e.g. power plant = long cycles (6 months)
- Widely varying conditions, e.g. daily CIP or SIP cleaning, fluctuating process pressure = short cycles (1 month or less)

The following method helps you determine the necessary intervals:

1. Inspect the sensor one month after commissioning. To do so, remove the sensor from the medium and dry it carefully.
2. To avoid measured errors in the transmitter, change the process pressure to the atmospheric pressure if not already the same.
 - ↳ If the process pressure and atmospheric pressure are the same, this step is not required.
3. After 10 minutes, measure the oxygen saturation index in air.
 - ↳ Decide using the results:
 - a) Measured value is not 100 ± 2 % SAT? → Service the sensor.
 - b) Measured value = 100 ± 2 % SAT? → Double the length of time to the next inspection.
4. Proceed as indicated in Step 1 after two, four and eight months.
 - ↳ This allows you to determine the optimum maintenance interval for your sensor.

i Especially in the case of widely fluctuating process conditions, damage to the membrane may also occur within a maintenance cycle. This is indicated by implausible sensor behavior.

9.2 Maintenance tasks

The following tasks must be performed:

1. Clean the sensor and glass body with the working electrode and counterelectrode (particularly if the membrane is dirty).
2. Replace wear parts or consumables.
3. Check measurement function.
4. Recalibrate (if desired or necessary).
 - ↳ Follow the Operating Instructions for the transmitter.

9.2.1 Cleaning the exterior of the sensor

Dirt on the sensor can impact the measurement and even cause a malfunction. Examples include buildup on the sensor membrane, which can cause a longer response time.

The sensor must be cleaned at regular intervals for reliable measurement results. The frequency and intensity of the cleaning process depend on the medium.

Clean the sensor:

- Before every calibration
- At regular intervals during operation as necessary
- Before returning it for repair

Type of contamination	Cleaning
Salt deposits	<ol style="list-style-type: none"> 1. Immerse the sensor in drinking water. 2. Then rinse it with copious amounts of water.
Dirt particles on the sensor shaft and shaft sleeve (not membrane!)	<ul style="list-style-type: none"> ▶ Clean sensor shaft and sleeve with water and a suitable sponge.
Dirt particles on the membrane or membrane body	<ul style="list-style-type: none"> ▶ Clean the membrane carefully with water and a soft cloth body

- ▶ After cleaning:
Rinse with copious amounts of clean water.

 Use a fully automated cleaning system for regular automated cleaning.

10 Repair

10.1 General notes

- ▶ Only use spare parts from Endress + Hauser to guarantee the safe and stable functioning of the device.

Detailed information on the spare parts is available at:

www.endress.com/device-viewer

10.2 Return

The product must be returned if repairs or a factory calibration are required, or if the wrong product was ordered or delivered. As an ISO-certified company and also due to legal regulations, Endress+Hauser is obliged to follow certain procedures when handling any returned products that have been in contact with medium.

To ensure the swift, safe and professional return of the device:

- ▶ Refer to the website www.endress.com/support/return-material for information on the procedure and conditions for returning devices.

The product must be returned if repairs or a factory calibration are required, or if the wrong product was ordered or delivered.

To ensure safe, professional and swift product returns, please contact your local Sales Center for information on the procedure to be followed and general conditions.

10.3 Spare parts and consumables

Parts of the sensor are subject to wear during operation. By taking suitable measures, you can restore the normal operating function.

Action required	Reason
Replace sealing rings	Visible damage to a sealing ring
Replace electrolyte	Unstable or implausible measuring signal or fouling of the electrolyte
Replace membrane body	Membrane is damaged or can no longer be cleaned (hole or overstretching)
Replace the internal body	Buildup on the working electrode

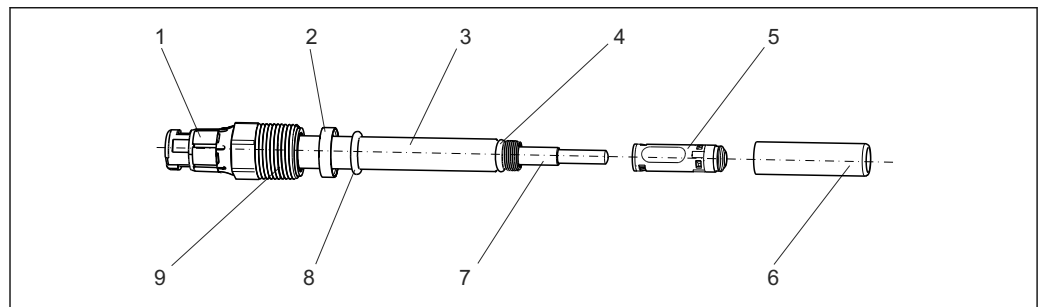

A0011869

10 COS22E

1 Plug-in head	4 O-ring 8.5 x 1.5 mm	7 Internal body with anode and cathode
2 Thrust collar	5 Membrane body	8 Process seal 10.77 x 2.62 mm
3 Sensor shaft	6 Shaft sleeve	9 Process connection Pg 13.5

Maintenance kit COS22Z

- Maintenance kit for COS22D and COS22E
- Scope of supply of maintenance kit COS22Z is based on the configuration:
 - 10 or 3 membrane bodies
 - O-ring mounting tool
 - O-rings
 - Electrolyte
 - Internal body
 - Shaft sleeve
 - Optionally ordered certificates, manufacturer inspection certificate
 - Ordering information: www.endress.com/cos22e under "Accessories/Spare parts"

10.3.1 Disassembling the sensor

The sensor must be disassembled if:

- Replacing the sealing ring for the shaft sleeve
- Replacing the electrolyte
- Replacing the membrane body
- Replacing the internal body

⚠ CAUTION

The standard electrolyte is a strong irritant

Danger of severe skin and eye irritation!

- ▶ Be absolutely certain to observe the corresponding workplace safety regulations.
- ▶ Wear protective gloves and goggles when handling the electrolyte.
- ▶ In case of eye contact: Remove contact lenses, rinse eyes with water for a few minutes and contact a doctor.
- ▶ In case of skin contact: Take off wet clothing immediately, wash the skin or take a shower.

i Also pay attention to the safety datasheet of the electrolyte on www.endress.com/downloads.

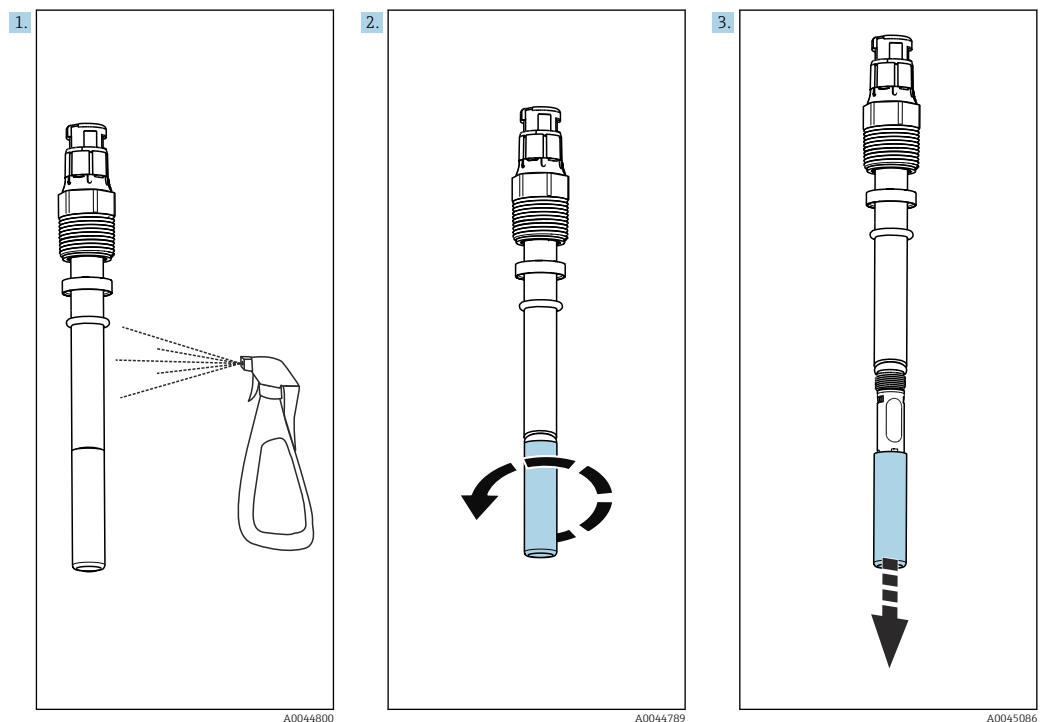

1. Disconnect the sensor from the transmitter, remove it from the process and clean it on the outside.

2. Hold the sensor vertically and unscrew the shaft sleeve.
 - ↳ Be careful of electrolyte leaking!
3. Remove the shaft sleeve.
 - ↳ The membrane body is located either in the shaft sleeve
or
is still on the internal body.

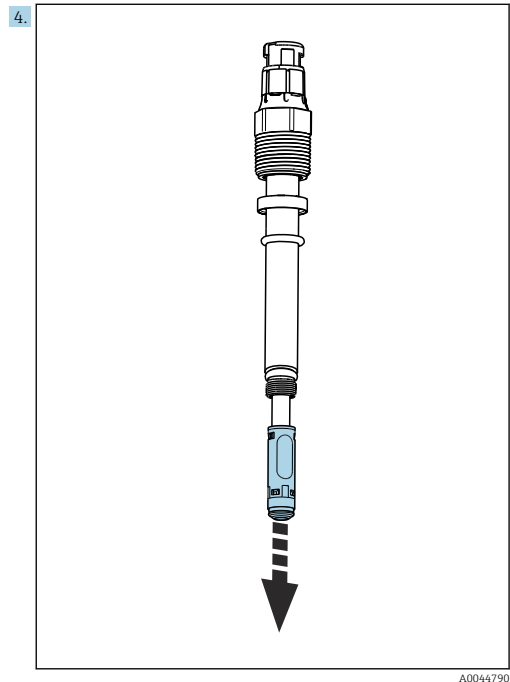
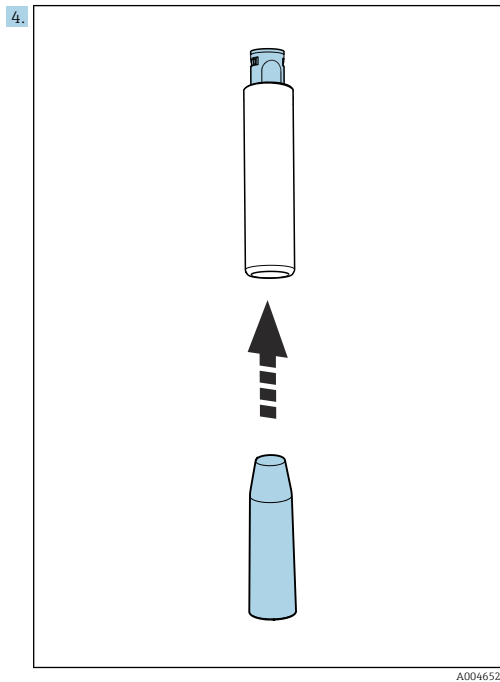







4. Remove the membrane body.
 - ↳ Remove the membrane body from the shaft sleeve using a removal tool.
or
Remove the membrane body from the internal body.

10.3.2 Replacing sealing rings

The replacement of the sealing ring is essential if visibly damaged. Use only original sealing rings .

The following O-rings can be replaced:

- Sealing ring for shaft sleeve: item 4 →  1,  8
- Sealing ring to process: item 8 →  1,  8

If the sealing ring on the membrane body (item 5 →  1,  8) is damaged, the entire membrane body must be replaced in accordance with the sensor version.

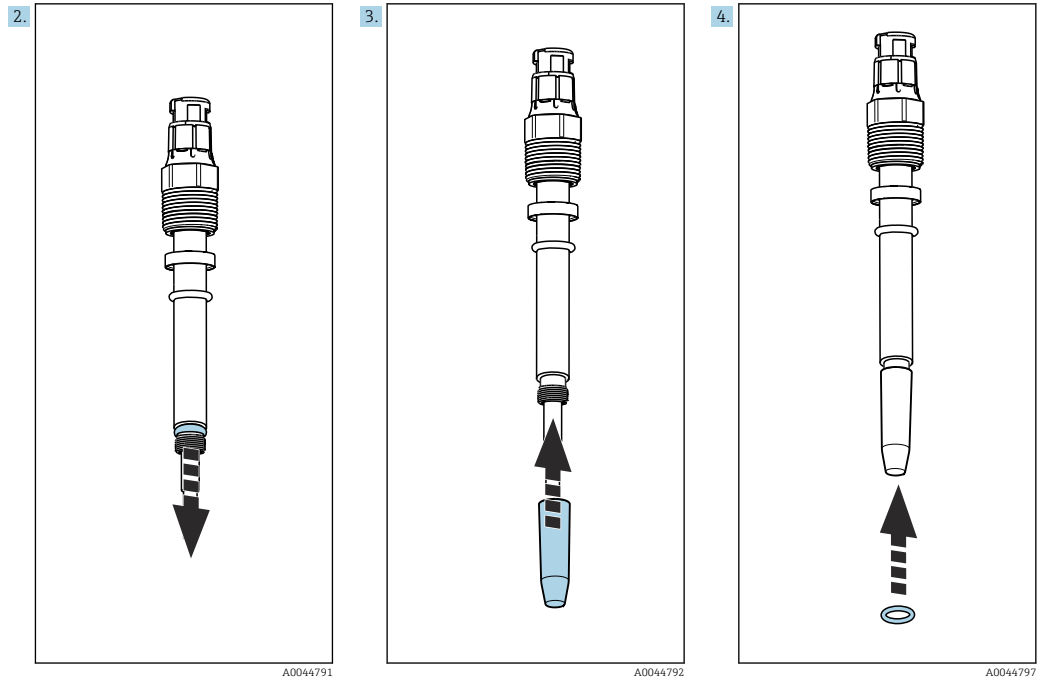

Replacing the sealing ring for the shaft sleeve

1. Disassemble the sensor →  27.

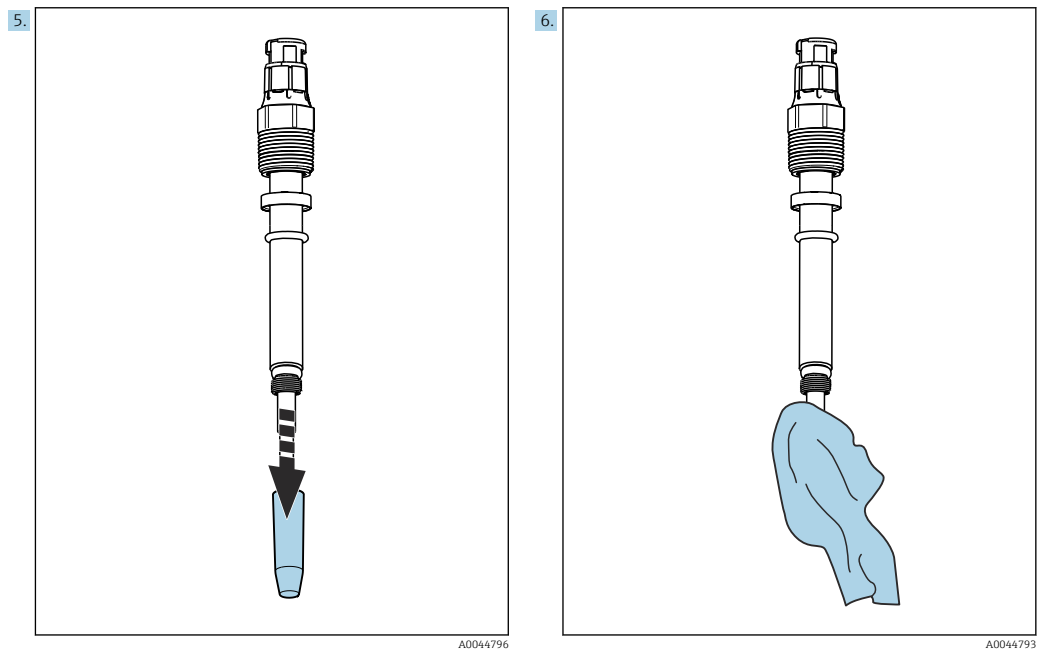

2. Remove the old O-ring above the thread on the shaft.
3. Push the mounting tool onto the shaft until it sits over the thread.
4. Slide the new O-ring over the mounting tool into the position above the thread.



5. Remove the mounting tool.
6. Rinse the internal body and dab carefully with a soft cleaning cloth.
7. Mount the sensor again →  33.
8. Put the sensor back into operation →  33.

Replacing the sealing ring towards the process

The sensor does **not** have to be disassembled when replacing the sealing ring towards the process.

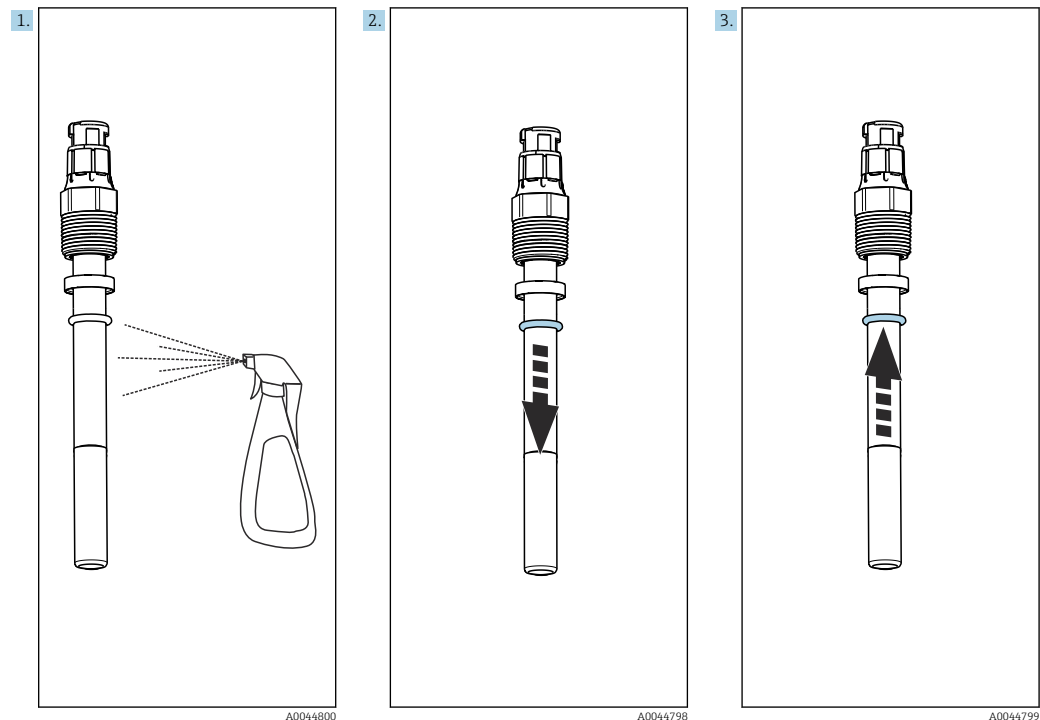

1. Disconnect the sensor from the transmitter, remove it from the process and clean it on the outside.
2. Remove the old O-ring on the process connection in the direction of the shaft sleeve.
3. Fit the new O-ring over the spot cap and push it as far as the process connection.
4. Put the sensor back into operation. → 📖 33

10.3.3 Replacing the electrolyte

The electrolyte is used up slowly during operation. This is caused by electrochemical substance reactions. In de-energized state, no substance reactions take place, and the electrolyte is not used up. The operating time of the electrolyte is shortened by diffusion of dissolved gases such as H_2S , NH_3 or high concentrations of CO_2 .

i The electrolyte depletion can be logged using a suitable transmitter. By setting warning limits it is possible to properly schedule sensor maintenance.

Theoretical operating time at $p_{\text{O}_2} = 210 \text{ mbar}$ and $T=20 \text{ }^\circ\text{C}$ (68 $^\circ\text{F}$)

COS22E-**22***** (standard sensor): > 1.5 years

COS22E-**12***** (trace sensor): > 3 months

i Each change in the concentration and temperature affects the operating time.

i Also pay attention to the safety datasheet of the electrolyte on www.endress.com/downloads.

Generally, the following applies:

- Sensors operated close to the lower measuring range limit have a low rate of chemical electrolyte consumption. The electrolyte does not have to be replaced for a long period.
- Sensors operated at high oxygen partial pressures (> 100 hPa) consume a significant amount of electrolyte. The electrolyte has to be replaced frequently.
- 25 ml electrolyte (provided in the maintenance kit) is sufficient for approx. membrane body approx. 15 times.

1. Disassemble the sensor → ☰ 27.
2. Dispose of the old electrolyte.

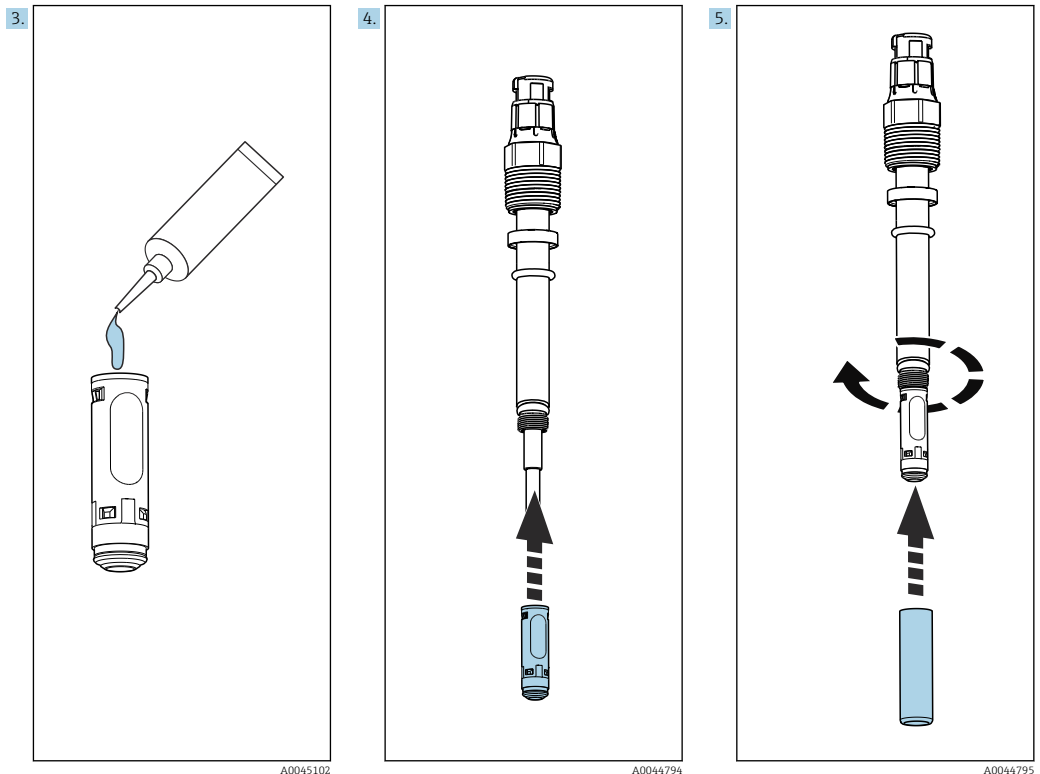

3. Hold the membrane body upright and fill it halfway with fresh electrolyte in accordance with the measuring range or sensor type.
 - ↳ Remove any air bubbles by tapping the side of the membrane body (e.g. using a pen/pencil).
4. Fit the membrane body on the internal body.
5. Fit the shaft sleeve and screw it on.
6. Put the sensor back into operation → ☰ 33.

10.3.4 Replacing the membrane body

The membrane body must be replaced if:

- The membrane is damaged or extended
- The sealing ring on the membrane body is damaged or worn

1. Disassemble the sensor → ☰ 27.
2. Dispose of the old membrane body and electrolyte.
3. Mount the sensor again → ☰ 33.
4. Put the sensor back into operation → ☰ 33.

10.3.5 Replacing the glass body with the working electrode

The internal body must be replaced if deposits form on the working electrode.

NOTICE

Polishing the working electrode may impair the function or lead to total failure of the sensor!

- ▶ Do not clean the working electrode by mechanical means.

1. Disassemble the sensor → ☰ 27.

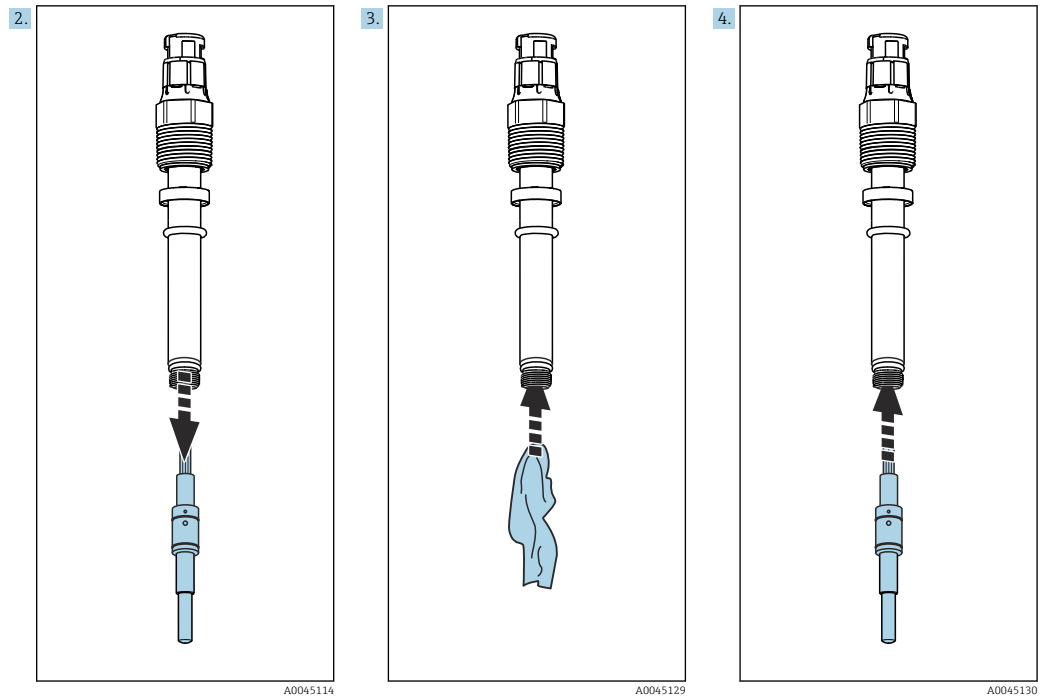

2. Pull the old internal body out of the electrode holder.
 - ↳ Do not turn it!
3. Dry the inside of the electrode holder.
4. Insert a new glass body (from the membrane kit) into the holder so that it fits.
 - ↳ Avoid damage to the electric pin contacts.
5. Mount the sensor → 33.

10.3.6 Mounting the sensor

⚠ CAUTION

The standard electrolyte is a strong irritant

Danger of severe skin and eye irritation!

- ▶ Be absolutely certain to observe the corresponding workplace safety regulations.
- ▶ Wear protective gloves and goggles when handling the electrolyte.
- ▶ In case of eye contact: Remove contact lenses, rinse eyes with water for a few minutes and contact a doctor.
- ▶ In case of skin contact: Take off wet clothing immediately, wash the skin or take a shower.

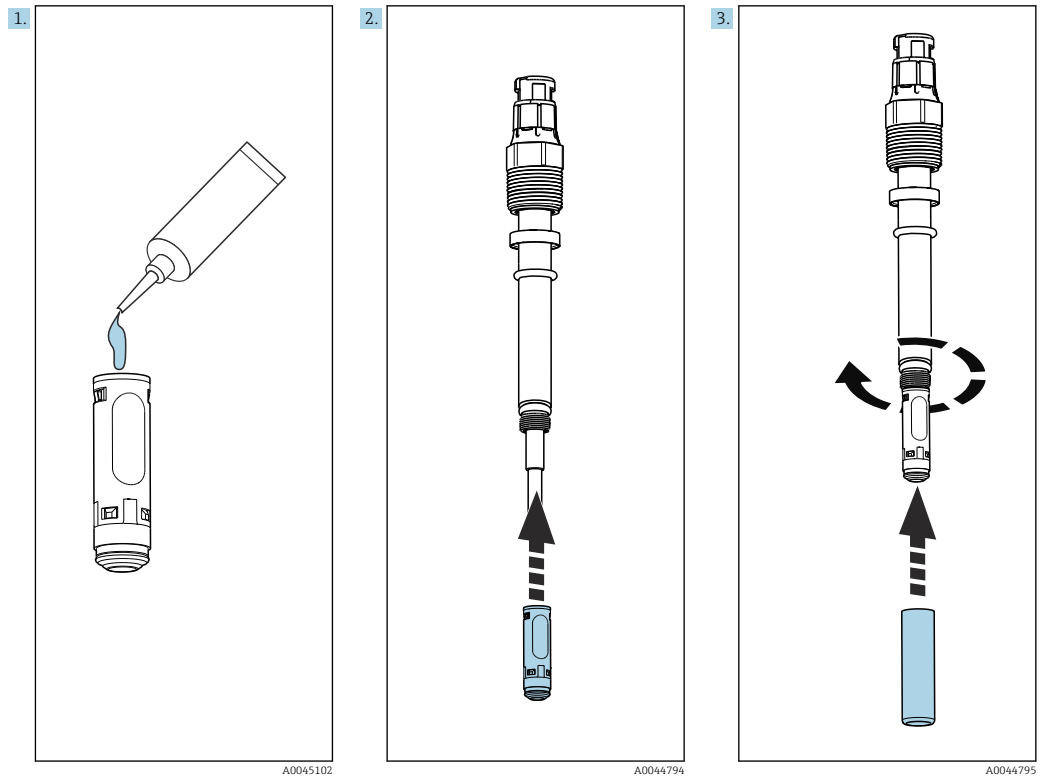

3. Hold the membrane body upright and fill it halfway with fresh electrolyte in accordance with the measuring range or sensor type.
 - ↳ Remove any air bubbles by tapping the side of the membrane body (e.g. using a pen/pencil).
4. Fit the membrane body on the internal body.
5. Fit the shaft sleeve and screw it on.

10.3.7 Putting the sensor back into operation

1. Connect the sensor to the transmitter.
2. Polarize the sensor and recalibrate it.
 - ↳ Observe the polarization time → 39.
3. After this:
 - Re-immerses the sensor into the medium.
4. Observe the medium pressure and, if necessary, adjust the pressure on the transmitter if different from the atmospheric pressure of the calibration.
5. Deactivate the hold at the transmitter.
6. Check that the transmitter does not signal an alarm.

10.4 Checking the measurement function

1. Remove the sensor from the medium.
2. Clean and dry the membrane.
3. Adjust the process pressure at the transmitter if it differs from the atmospheric pressure; otherwise, a comparison will not be possible.
4. After about 10 minutes, measure the oxygen saturation index in air (without recalibration).
 - ↳ The measured value should be at 100 ± 2 % SAT.

10.5 Disposal



If required by the Directive 2012/19/EU on waste electrical and electronic equipment (WEEE), the product is marked with the depicted symbol in order to minimize the disposal of WEEE as unsorted municipal waste. Do not dispose of products bearing this marking as unsorted municipal waste. Instead, return them to Endress+Hauser for disposal under the applicable conditions.

11 Accessories

The following are the most important accessories available at the time this documentation was issued.

- ▶ For accessories not listed here, please contact your Service or Sales Center.

11.1 Device-specific accessories

11.1.1 Assemblies (selection)

Cleanfit CPA875

- Retractable process assembly for sterile and hygienic applications
- For in-line measurement with standard sensors with 12 mm diameter, e.g. for pH, ORP, oxygen
- Product Configurator on the product page: www.endress.com/cpa875

 Technical Information TI01168C

Cleanfit CPA871

- Flexible process retractable assembly for water, wastewater and the chemical industry
- For applications with standard sensors with 12 mm diameter
- Product Configurator on the product page: www.endress.com/cpa871

 Technical Information TI01191C

Unifit CPA842

- Installation assembly for food, biotechnology and pharmaceuticals
- With EHEDG and 3A certificate
- Product Configurator on the product page: www.endress.com/cpa842

 Technical Information TI00306C

Flowfit CPA240

- pH/redox flow assembly for processes with stringent requirements
- Product Configurator on the product page: www.endress.com/cpa240

 Technical Information TI00179C

Flowfit CYA21

- Universal assembly for analysis systems in industrial utilities
- Product Configurator on the product page: www.endress.com/CYA21

 Technical Information TI01441C

11.1.2 Measuring cable

Memosens data cable CYK10

- For digital sensors with Memosens technology
- Product Configurator on the product page: www.endress.com/cyk10

 Technical Information TI00118C

Memosens data cable CYK11

- Extension cable for digital sensors with Memosens protocol
- Product Configurator on the product page: www.endress.com/cyk11

 Technical Information TI00118C

Memosens laboratory cable CYK20

- For digital sensors with Memosens technology
- Product Configurator on the product page: www.endress.com/cyk20

11.1.3 Zero-point gel**COY8**

Zero-point gel for oxygen and disinfection sensors

- Oxygen-free and chlorine-free gel for the verification, zero point calibration and adjustment of oxygen and disinfection measuring points
- Product Configurator on the product page: www.endress.com/coy8



Technical Information TI01244C

11.1.4 Transmitter**Liquiline CM44**

- Modular multi-channel transmitter for hazardous and non-hazardous areas
- HART®, PROFIBUS, Modbus or EtherNet/IP is possible
- Order according to product structure



Technical Information TI00444C

Liquiline CM42

- Modular two-wire transmitter for hazardous and non-hazardous areas
- HART®, PROFIBUS or FOUNDATION Fieldbus is possible
- Order according to product structure



Technical Information TI00381C

Liquiline Mobile CML18

- Multiparameter mobile device for laboratory and field
- Reliable transmitter with display and app connection
- Product Configurator on the product page: www.endress.com/CML18



Operating Instructions BA02002C

Liquiline Compact CM82

- Configurable 1-channel multiparameter transmitter for Memosens sensors
- Ex- and non-ex applications possible in all industries
- Product Configurator on the product page: www.endress.com/CM82



Technical Information TI01397C

Liquiline Compact CM72

- 1-channel single parameter field device for Memosens sensors
- Ex- and non-ex applications possible in all industries
- Product Configurator on the product page: www.endress.com/CM72



Technical Information TI01409C

Memobase Plus CYZ71D

- PC software to support laboratory calibration
- Visualization and documentation of sensor management
- Sensor calibrations stored in database
- Product Configurator on the product page: www.endress.com/cyz71d



Technical Information TI00502C

11.1.5 Maintenance kit

Maintenance kit COS22Z

- Maintenance kit for COS22D and COS22E
- Scope of supply of maintenance kit COS22Z is based on the configuration:
 - 10 or 3 membrane bodies
 - O-ring mounting tool
 - O-rings
 - Electrolyte
 - Internal body
 - Shaft sleeve
 - Optionally ordered certificates, manufacturer inspection certificate
 - Ordering information: www.endress.com/cos22e under "Accessories/Spare parts"

12 Technical data

12.1 Input

Measured variables Dissolved oxygen [mg/l, µg/l, ppm, ppb, %SAT, %Vol, ppmVol, raw value nA, hPa]
 Temperature [°C, °F]

measuring range Measuring ranges apply for 20 °C (68 °F) and 1013 hPa (15 psi)

	Measuring range	Optimum measuring range ¹⁾
COS22E-**22**** (standard sensor)	0 to 60 mg/l 0 to 600 % SAT 0 to 1200 hPa 0 to 100 Vol%	0 to 20 mg/l 0 to 200 % SAT 0 to 400 hPa 0 to 40 Vol%
COS22E-**12**** (trace sensor)	0 to 10 mg/l 0 to 120 % SAT 0 to 250 hPa 0 to 25 Vol%	0 to 2 mg/l 0 to 20 % SAT 0 to 40 hPa 0 to 4 Vol%

1) Applications in this range guarantee a long service life and low maintenance

i The sensor has a measuring range up to max. 1200 hPa.
 The specified measured errors are achieved in the optimum measuring range, but not over the entire measuring range.

12.2 Power supply

Electrical connection The electrical connection of the sensor to the transmitter is established using measuring cable CYK10.

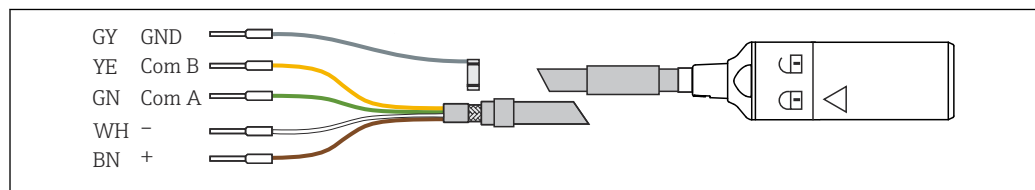

11 Measuring cable CYK10

12.3 Performance characteristics

Response time ¹⁾ From air to nitrogen at reference ¹⁾ operating conditions:
 ■ $t_{90} : < 30 \text{ s}$
 ■ $t_{98} : < 60 \text{ s}$

1) Average of all sensors that have undergone a final inspection

Reference operating conditions	Reference temperature: Reference pressure: Reference application:	20 °C (68 °F) 1013 hPa (15 psi) Air-saturated water
Signal current in air	COS22E-**22***** (standard sensor): COS22E-**12***** (trace sensor):	40 to 100 nA 210 to 451 nA
Zero current	COS22E-**22***** (standard sensor): COS22E-**12***** (trace sensor):	< 0.1 % of the signal current in air < 0.03 % of the signal current in air
Maximum measured error ²⁾	COS22E-**22 (standard sensor): COS22E-**12 (trace sensor):	≤ ±1 % of the measured value or 10 ppb (the higher value is relevant) ≤ ±1 % of the measured value or 1 ppb (the higher value is relevant)
Limit of detection (LOD) ³⁾	COS22E-**22 (standard sensor): COS22E-**12 (trace sensor):	5 ppb 1 ppb
Limit of quantification (LOQ) ³⁾	COS22E-**22 (standard sensor): COS22E-**12 (trace sensor):	15 ppb 3 ppb
Repeatability	COS22E-**22 (standard sensor): COS22E-**12 (trace sensor):	5 ppb 1 ppb
Long-term drift ⁴⁾	< 4 % per month in reference operating conditions < 1 % per month in operation with reduced oxygen concentration (< 4 Vol% O ₂)	
Influence of the medium pressure	Pressure compensation via setting options on the transmitter.	
Polarization time	COS22E-**22***** (standard sensor): COS22E-**12***** (trace sensor):	< 30 min for 98% signal value, 2 h for 100% < 3 h for 98% signal value, 12 h for 100%
Intrinsic oxygen consumption	COS22E-**22***** (standard sensor): COS22E-**12***** (trace sensor):	approx. 20 ng/h in air at 20 °C (68 °F) approx. 100 ng/h in air at 20 °C (68 °F)
Electrolyte	COS22E-**22***** (standard sensor): COS22E-**12***** (trace sensor):	basic electrolyte Neutral electrolyte
Operating time of the electrolyte	The electrolyte is used up slowly during operation. This is caused by electrochemical substance reactions. In de-energized state, no substance reactions take place, and the	

2) In accordance with IEC 60746-1 at rated operating conditions

3) According to DIN EN ISO 15839. The measured error contains all the uncertainties of the sensor and transmitter (measuring chain). It does not contain all the uncertainties caused by the reference material and adjustments that may have been performed.

4) Under constant conditions

electrolyte is not used up. The operating time of the electrolyte is shortened by diffusion of dissolved gases such as H₂S, NH₃ or high concentrations of CO₂.

Theoretical operating time at p_{O2} = 210 mbar and T=20 °C (68 °F)

COS22E-**22***** (standard sensor): > 1.5 years

COS22E -**12***** (trace sensor): > 3 months

⚠ CAUTION

The standard electrolyte is a strong irritant

Danger of severe skin and eye irritation!

- ▶ Be absolutely certain to observe the corresponding workplace safety regulations.
- ▶ Wear protective gloves and goggles when handling the electrolyte.
- ▶ In case of eye contact: Remove contact lenses, rinse eyes with water for a few minutes and contact a doctor.
- ▶ In case of skin contact: Take off wet clothing immediately, wash the skin or take a shower.

Generally, the following applies:

- The electrolyte must be replaced if the membrane body is removed.
- Sensors operated close to the zero point consume hardly any chemical electrolyte. The electrolyte does not have to be replaced for a long period.
- Sensors operated at high oxygen partial pressures (> 100 hPa) consume a significant amount of electrolyte. The electrolyte has to be replaced frequently.
- 25 ml electrolyte provided in the maintenance kit is sufficient for approx. membrane body approx. 15 times.

Temperature compensation Temperature compensation takes place across the entire specified range for all measured variables.

12.4 Environment

Ambient temperature range	Temperature range T4	Temperature range T6
COS22E	-25 °C ≤ T _a ≤ 70 °C (T4) -13 °F ≤ T _a ≤ 158 °F	-25 °C ≤ T _a ≤ 70 °C (T6) -13 °F ≤ T _a ≤ 158 °F

i The temperature range may differ for Ex versions. The XA "Safety instructions for electrical equipment in hazardous areas" for the product must be followed.

Storage temperature range -25 to 50 °C (77 to 120 °F)

NOTICE

Danger of sensor drying out!

- ▶ Store the sensor with the watering cap only (filled with tap water).

Degree of protection IP68 (2 m (6.5 ft) water column, 21 °C (70 °F), 24 hours)
IP69

Relative humidity 0 to 100%

12.5 Process

Process temperature range

	Temperature range T4	Temperature range T6
COS22E	$-5 \leq T_p \leq 100 \text{ °C}$ (T4)	$-5 \leq T_p \leq 70 \text{ °C}$ (T6)

i The temperature range may differ for Ex versions. The XA "Safety instructions for electrical equipment in hazardous areas" for the product must be followed.

Process pressure range

Ambient pressure ... 12 bar (... 174 psi) absolute

Temperature/pressure ratings

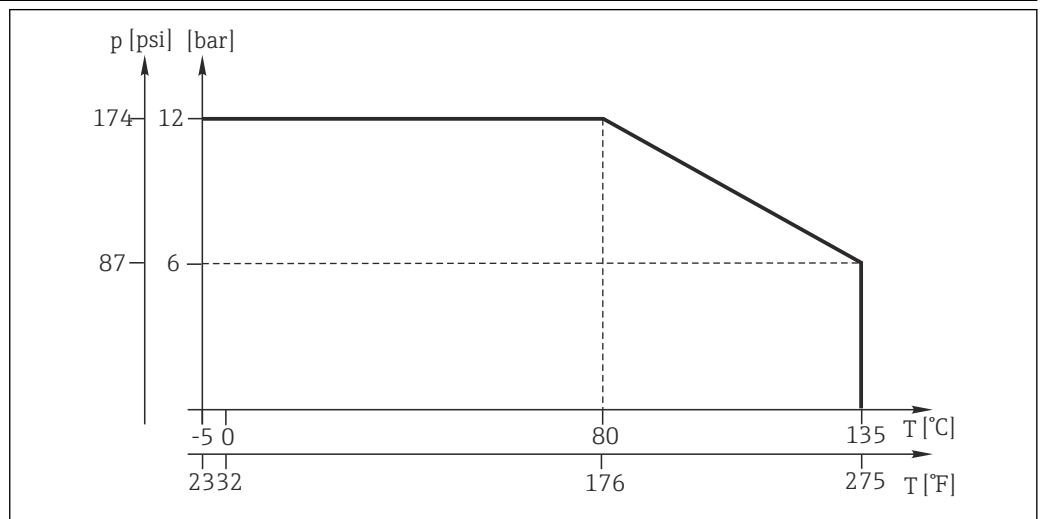

A0046381

Minimum flow

COS22E-**22***** (standard sensor):	0.02 m/s (0.07 ft/s)
COS22E-**12***** (trace sensor):	0.1 m/s (0.33 ft/s)

Chemical resistance

Parts in contact with the medium are chemically resistant to:

- Diluted acids and alkalis
- Hot water and superheated steam up to max. 140 °C (284 °F) during sterilization
- CO₂ up to 100 %, only with trace sensor COS22E-**12*****

NOTICE

Hydrogen sulfide and ammonia shorten the operating life of the sensor!

- ▶ Do not use the sensor in applications where it is exposed to hydrogen sulfide or ammonia vapors.

CIP compatibility

Yes

SIP compatibility

Yes, max. 140 °C (284 °F)

Autoclavability

Yes, max. 140 °C (284 °F), 30 min

Cross-sensitivity

COS22E-**12/22

Molecular hydrogen causes false low readings and can, in a worst-case scenario, result in total failure of the sensor.

For a sensor version that is resistant to hydrogen, contact the Endress+Hauser sales team.

12.6 Mechanical construction

Dimensions

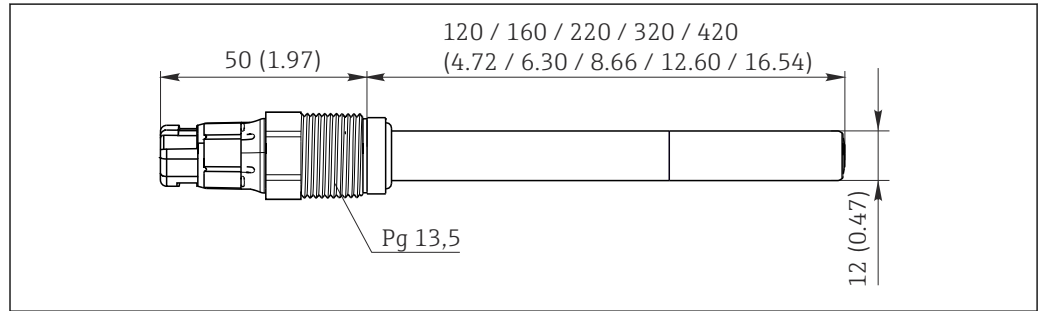

12 Dimensions in mm (inch)

Optional flow assembly CYA21 for sensors with Ø 12 mm (accessories)

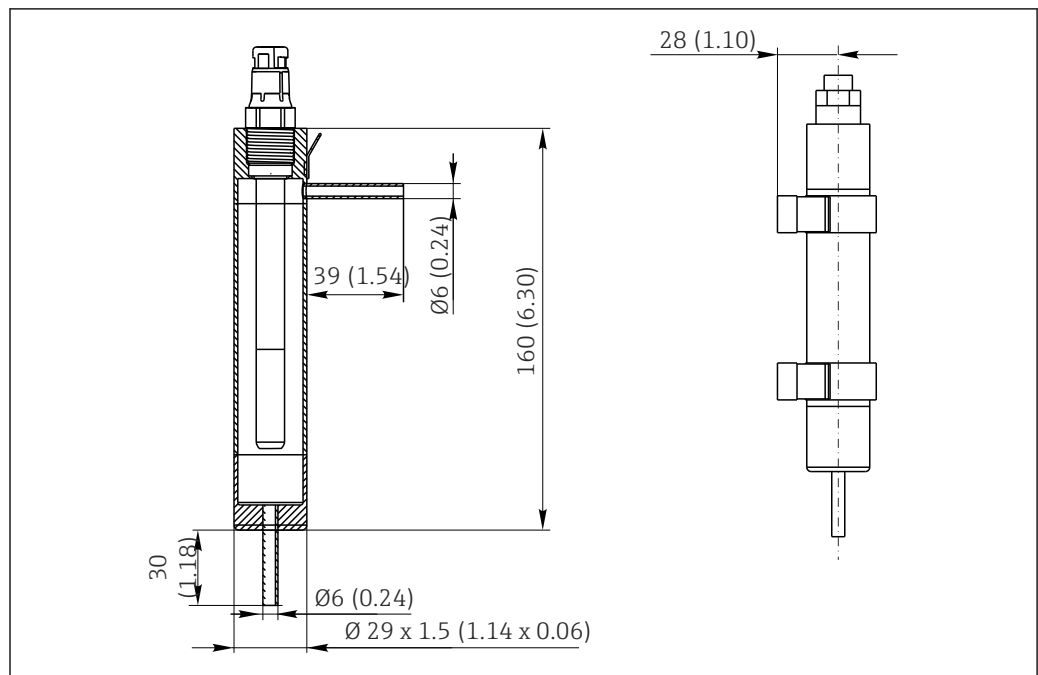

13 Dimensions in mm (inch)

Weight

Depending on the design (length)
0.2 kg (0.44 lbs) to 0.7 kg (1.54 lbs)

Materials

Parts in contact with medium

Sensor shaft

Stainless steel 1.4435 (AISI 316L)

Process seal

FKM (USP<87>, <88> Class VI and FDA)

Process seal for Ex versions

FKM (not FDA-compliant)

Seals/O-rings

EPDM (USP<87>, <88> Class VI and FDA),
FKM (FDA)

	Shaft sleeve	Stainless steel 1.4435 (AISI 316L) or titanium or Hastelloy
	Top layer of membrane	Silicone (USP<87>, <88> Class VI and FDA)
Process connection	Pg 13.5 Torque max. 3 Nm	
Surface roughness	$R_a < 0.38 \mu\text{m}$	
Temperature sensor	NTC 22 k Ω	

Index

A

Accessories	35
Adjustment	19
Ambient temperature range	40
Assemblies	35
Autoclavability	41

C

Calibration	19
Air	20
Calculation example	20
Oxygen	20
Types of calibration	19
Zero point calibration	19
Chemical resistance	41
CIP compatibility	41
Cleaning	
Exterior	24
Commissioning	18
Connection	38
Cross-sensitivity	42

D

Degree of protection	17, 40
Diagnostics	23
Dimensions	12, 42
Disposal	34
Documentation	
Supplementary safety instructions	5

E

Electrical connection	17, 38
Electrolyte	39
Operating time	30
Replacement	30
Environment	40

F

Function check	18
--------------------------	----

G

Glass body	31
----------------------	----

I

Incoming acceptance	10
Input	38
Installation	12
Installation requirements	12
Intended use	6

L

Limit of detection	39
Long-term drift	39

M

Maintenance	24
Materials	42

Measured error	39
Measured variables	38
Measurement function	33
Measuring cable	35
Measuring principle	8
Measuring range	38
Measuring system	13
Mechanical construction	42
Medium pressure	39
Membrane body	
Replacement	31
Minimum flow	41
Mounting	12
Mounting requirements	12

N

Nameplate	10
---------------------	----

P

Performance characteristics	38
Polarization time	39
Post-connection check	17
Post-mounting check	16
Power supply	38
Pressure/temperature ratings	41
Process	41
Process connection	43
Process pressure range	41
Process temperature range	41
Product description	8
Product design	8
Product identification	10
Product safety	7

R

Reference operating conditions	39
Repair	26
Repeatability	39
Response time	38
Return	26

S

Safety instructions	6
Scope of delivery	11
Sensor	
Polarization	18
Sensor connection	17
Signal current in air	39
SIP compatibility	41
Storage temperature range	40
Surface roughness	43
Symbols	4

T

Technical data	38
Performance characteristics	38
Power supply	38

Temperature compensation	40
Temperature sensor	43
Temperature/pressure ratings	41
Troubleshooting	23

U

Use	6
---------------	---

W

Warnings	4
Weight	42
Working electrode	31

Z

Zero current	39
Zero solution	
Application	19
Zero-point gel	36



71556088

www.addresses.endress.com
