

# Technical Information

## Liquiline CM44P

Universal four-wire multichannel controller for process photometers and Memosens sensors



### Field device or cabinet device

#### Application

- Food and beverages
- Life science
- Power stations
- Chemical industry
- Other industrial applications

#### Your benefits

- Highly flexible:
  - Able to connect up to 2 process photometers
  - Mathematics functions calculate new measured values
  - Digital fieldbuses (HART, PROFIBUS, Modbus, Ethernet/IP) and integrated web server
  - Choice of cleaning function, controller and alarm relay
  - Optional digital or analog inputs/outputs
- Maximum process safety thanks to standardized operating concept across all devices in the Liquiline, sampler and analyzer platform
- Fast commissioning thanks to:
  - Memosens: lab-calibrated sensors & hot plug-and-play
  - Preconfigured Liquiline transmitter
  - Easy extension and adaptation
- Minimum inventory:
  - Cross-platform, modular concept (e.g. identical modules irrespective of parameters)
  - Integration into Fieldcare and W@M facilitates effective asset management

## Table of contents

<b>Function and system design</b> . . . . .	<b>4</b>	<b>Current outputs, active</b> . . . . .	<b>20</b>
Measuring system with photometer . . . . .	4	Span . . . . .	20
Measuring system with optional Memosens sensors . . . . .	5	Signal characteristic . . . . .	20
Application example . . . . .	6	Electrical specification . . . . .	20
		Cable specification . . . . .	20
<b>Device architecture</b> . . . . .	<b>7</b>	<b>Relay outputs</b> . . . . .	<b>20</b>
Slot and port assignment . . . . .	7	Electrical specification . . . . .	20
Order of the modules . . . . .	7	Cable specification . . . . .	21
Basic rule for hardware upgrades . . . . .	7	<b>Protocol-specific data</b> . . . . .	<b>21</b>
Determining the hardware delivery status . . . . .	8	HART . . . . .	21
Terminal diagram . . . . .	8	PROFIBUS DP . . . . .	21
Device configuration using the example of a CM44P-** . . . . .	9	Modbus RS485 . . . . .	22
Block circuit diagram of CM44P-** . . . . .	10	Modbus TCP . . . . .	22
		EtherNet/IP . . . . .	22
<b>Communication and data processing</b> . . . . .	<b>11</b>	Web server . . . . .	23
<b>Dependability</b> . . . . .	<b>11</b>	<b>Power supply</b> . . . . .	<b>23</b>
Reliability . . . . .	11	Supply voltage . . . . .	23
Maintainability . . . . .	13	Power consumption . . . . .	23
Safety . . . . .	16	Fuse . . . . .	23
<b>Input</b> . . . . .	<b>17</b>	Overvoltage protection . . . . .	23
Measured variables . . . . .	17	Cable entries (field device only) . . . . .	24
Measuring ranges . . . . .	17	Cable specification . . . . .	24
Types of input . . . . .	17	Electrical connection . . . . .	24
Input signal . . . . .	17	Connecting optional modules . . . . .	26
Cable specification . . . . .	17	Protective ground connection . . . . .	28
<b>Digital inputs, passive</b> . . . . .	<b>17</b>	Sensor connection . . . . .	28
Electrical specification . . . . .	17	<b>Performance characteristics</b> . . . . .	<b>31</b>
Span . . . . .	17	Response time . . . . .	31
Nominal input current . . . . .	18	Reference temperature . . . . .	31
PFM function . . . . .	18	Measured error for sensor inputs . . . . .	31
Test voltage . . . . .	18	Measured error for current inputs and outputs . . . . .	31
Cable specification . . . . .	18	Frequency tolerance of digital inputs and outputs . . . . .	32
<b>Current input, passive</b> . . . . .	<b>18</b>	Resolution of current inputs and outputs . . . . .	32
Span . . . . .	18	Repeatability . . . . .	32
Signal characteristic . . . . .	18	<b>Installation</b> . . . . .	<b>32</b>
Internal resistance . . . . .	18	Installation conditions . . . . .	32
Test voltage . . . . .	18	Installation . . . . .	33
<b>Output</b> . . . . .	<b>18</b>	Mounting on DIN rail as per IEC 60715 . . . . .	34
Output signal . . . . .	18	Wall mounting . . . . .	35
Signal on alarm . . . . .	19	Mounting the external display . . . . .	36
Load . . . . .	19	<b>Environment</b> . . . . .	<b>36</b>
Linearization/transmission behavior . . . . .	19	Ambient temperature range . . . . .	36
<b>Digital outputs, passive</b> . . . . .	<b>19</b>	Storage temperature . . . . .	36
Electrical specification . . . . .	19	Humidity . . . . .	36
External power supply . . . . .	19	Degree of protection . . . . .	36
PFM function . . . . .	19	Climate class (cabinet device only) . . . . .	37
Auxiliary voltage . . . . .	20	Vibration resistance . . . . .	37
Test voltage . . . . .	20	Electromagnetic compatibility . . . . .	37
Cable specification . . . . .	20	Electrical safety . . . . .	37
		Degree of contamination . . . . .	37
		Pressure compensation to environment (field device only) . . . . .	37

<b>Mechanical construction</b> . . . . .	<b>38</b>
Dimensions . . . . .	38
Weight . . . . .	41
Materials . . . . .	42
<b>Operability</b> . . . . .	<b>42</b>
display . . . . .	42
Operating concept . . . . .	42
Local operation . . . . .	43
Remote operation . . . . .	43
Language packages . . . . .	45
<b>Certificates and approvals</b> . . . . .	<b>45</b>
CE mark . . . . .	45
<b>Ordering information</b> . . . . .	<b>46</b>
Product page . . . . .	46
Product Configurator . . . . .	46
Scope of delivery . . . . .	46
<b>Accessories</b> . . . . .	<b>46</b>
Measuring cable . . . . .	46
Sensors . . . . .	46
Additional functionality . . . . .	51
Software . . . . .	53
Other accessories . . . . .	53

## Function and system design

### Measuring system with photometer

An optical measuring system comprises:

- Transmitter, e. g. Liquiline CM44P
- Sensor (photometer), e. g. OUSAF11/12/21/22/44/46, OUSTF10 or OUSBT66
- Cable set, e. g. CUK80
- The correct assembly for the sensor, e. g. OUA260
- The following are optional:
  - Post retainer
  - Protective cover
  - Memosens sensors (→ 5)

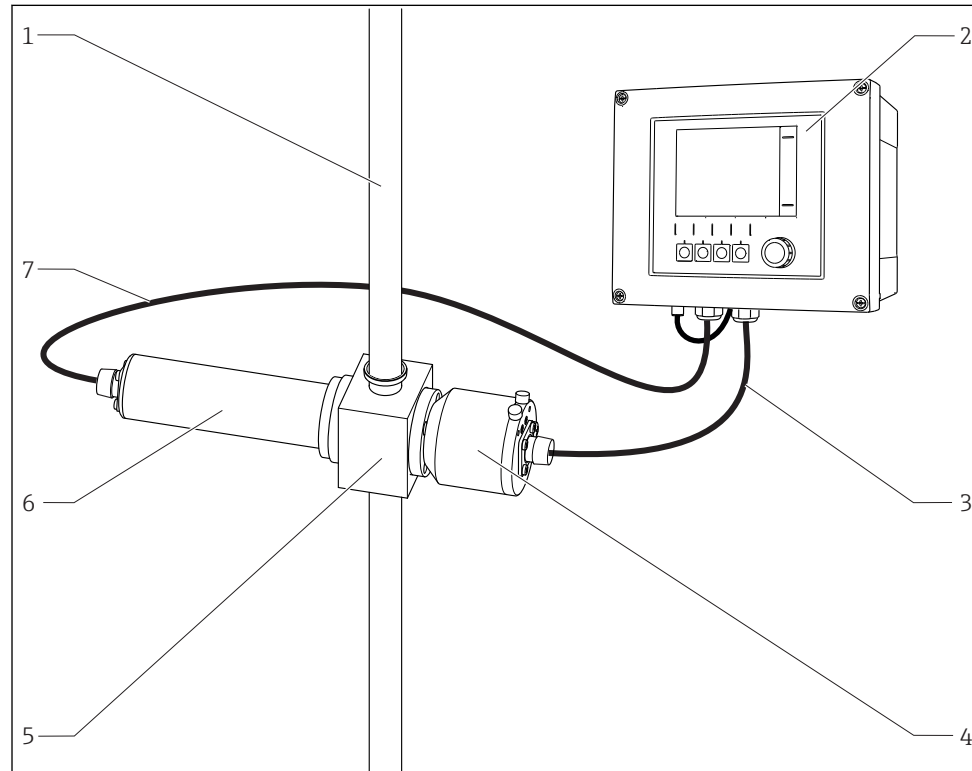

1 Example of a measuring system with a photometer sensor

- |   |                   |   |                             |
|---|-------------------|---|-----------------------------|
| 1 | pipe              | 5 | Flow assembly OUA260        |
| 2 | Transmitter CM44P | 6 | Sensor: light source (lamp) |
| 3 | CUK80 cable set   | 7 | CUK80 cable set             |
| 4 | Sensor: detector  |   |                             |

**i** You can combine your measuring point with a variety of Memosens sensors and suitable assemblies (→ 5). For more information, visit [www.endress.com/cm44p](http://www.endress.com/cm44p)

**Measuring system with optional Memosens sensors**

The overview shows examples of measuring systems. Other sensors and assemblies can be ordered for conditions specific to your application ([www.endress.com/products](http://www.endress.com/products)).

**Measuring point**

A measuring system comprises:

- Transmitter Liquiline
- Optional display (for cabinet device)
- Sensors with Memosens technology
- Assemblies to suit the sensors used
- Post or rail mounting (optional, for field device)
- Weather protection cover (optional, for field device)

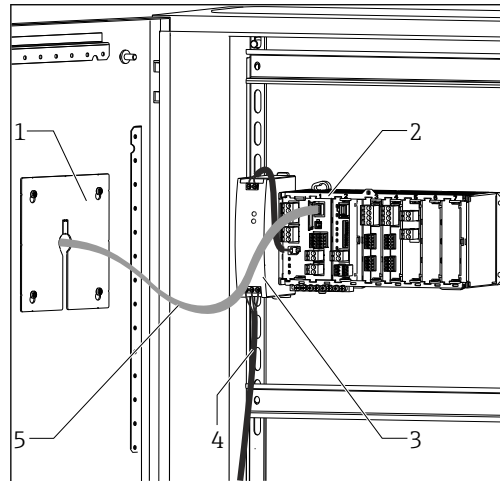

2 Cabinet installation (without sensor and signal cables)

- 1 Optional display (back)
- 2 Liquiline
- 3 External power unit
- 4 Power cable (to be provided by the customer)
- 5 Display cable

**Nitrate and SAC**

Nitrate in wastewater

- Sensor CAS51D-\*\*A2 with fixed cable
- Dipfit CYA112 immersion assembly
- Holder CYH112

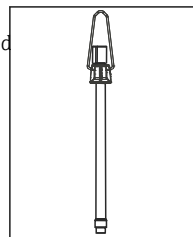

SAC in the wastewater treatment outlet

- Sensor CAS51D-\*\*2C2 with fixed cable
- Dipfit CYA112 immersion assembly
- Holder CYH112

**Disinfection**

Free available chlorine (and pH) in drinking water

- Sensor CCS142D
- Sensor CPS11D
- Measuring cable CYK10
- Flow assembly CCA250

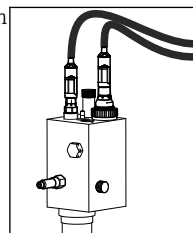

**pH value or ORP**

pH measurement in the pharmaceutical industry

- Retractable assembly Cleanfit CPA871
- Sensor Orbisint CPS11D
- Measuring cable CYK10

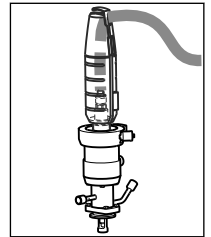

ORP in drinking water

- Dipfit CYA112 immersion assembly
- Sensor Orbisint CPS12D
- Measuring cable CYK10

**Conductivity**

Inductive conductivity measurement in the food industry

- Sensor Indumax CLS54D
- Sensor fixed cable

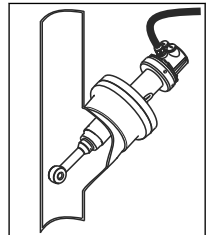

Conductive conductivity measurement in power plant cooling water

- Sensor Condumax CLS15D
- Measuring cable CYK10

**Oxygen**

Oxygen in aeration basins

- Dipfit CYA112 immersion assembly
- Holder CYH112
- Sensor
  - COS61D (optical) with fixed cable (→ Fig.)
  - COS51D (amperometric), cable CYK10

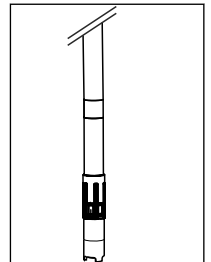

**Turbidity and interface**

Turbidity in industrial water

- Sensor Turbimax CUS51D with fixed cable (→ Fig.)
- Assembly Flowfit CUA250
- Spray head CUR3 (optional)

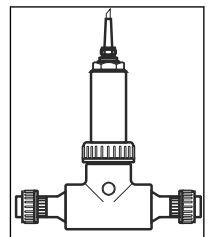

Interface in the primary clarifier

- Sensor Turbimax CUS71D
- Assembly CYA112
- Holder CYH112

**Ion-selective electrodes**

Ammonium and nitrate measurement in the aeration basin

- Sensor CAS40D with fixed cable
- Holder CYH112

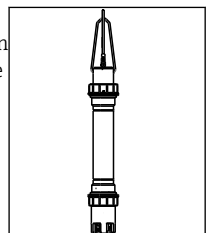

**i** If mounting outdoors, always use the weather protection cover (see "Accessories") to protect the transmitter against weather conditions.

## Application example

## Measuring point in chromatography monitoring

Transmitter CM44P-AADINP1M22A1FG15BAEA+PK (cabinet device) with:

- 1 photometer input, 2 Memosens inputs, PROFIBUS, 2 analog outputs and 2 digital inputs
- Optional display
- Photometer OUSAF44 (item 4)
- Flow assembly OUA260-AA1C05B1A3A with 2 mm path length and POPL, Triclamp 1/2", quartz window, item 3 (www.endress.com/oua260)
- Flow assembly CYA680 with 2x Pg 13.5 process connection for Memosens sensors, item 1
- pH and temperature with CPS71D, item 2 (www.endress.com/cps71d)
- Conductivity, conductive four-pin sensor CLS82D, item 5 (www.endress.com/cls82d)

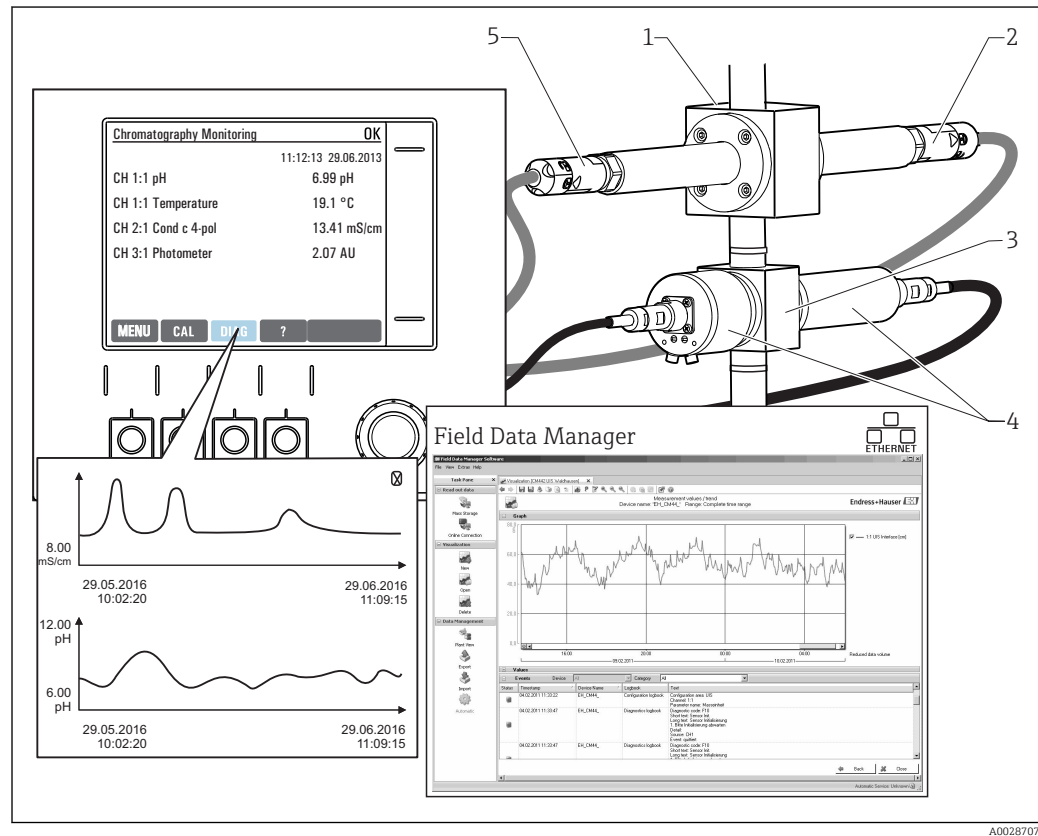

A0028707

3 Measuring point in chromatography monitoring

## Data retention

- Storage of all measured values, incl. values of external sources, in the non-volatile memory (data logbook)
- Data called up on site via user-defined measuring menu and load curve display of the data logbook
- Transmission of data by ethernet, CDI interface or SD card and storage in a tamper-proof database (Field Data Manager)
- Data export to csv file (for Microsoft Excel)

## Device architecture

### Slot and port assignment

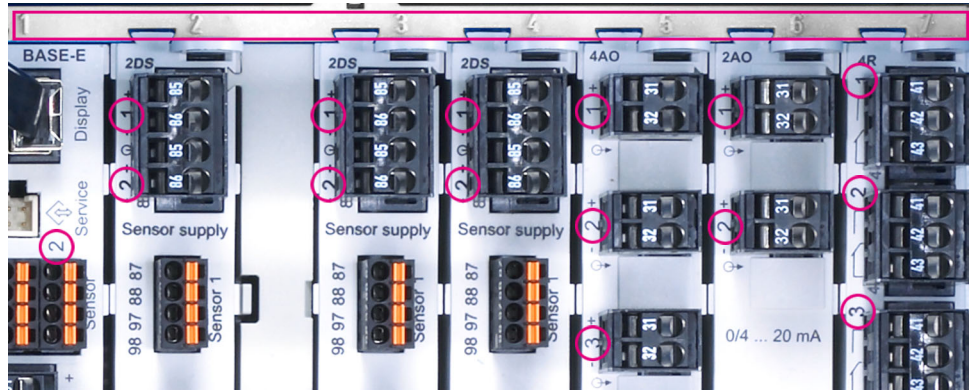
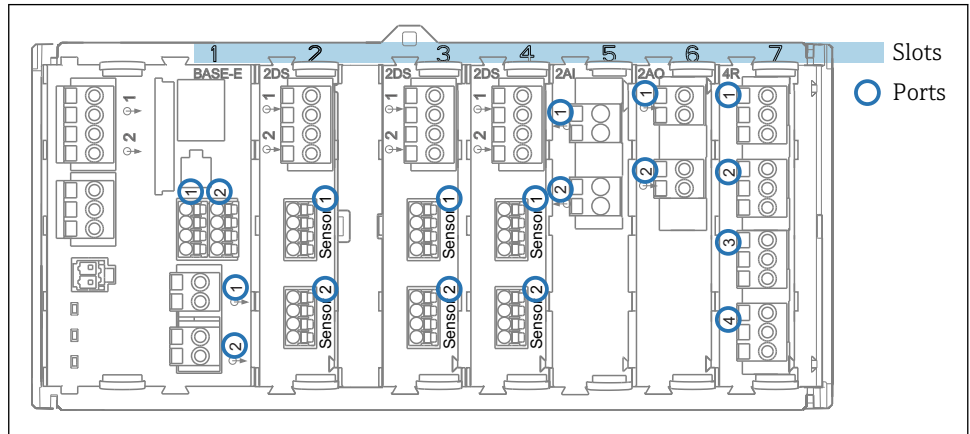

4 Slot and port assignment of the hardware modules

Outlet 1		OK
CH1: 1:1 pH Glass	ATC 6.95 pH	Port Slot
CH2: 1:2 TU/TS	500.0 g/l	
CH3: 5:1 SAC	500.0 1/m	
CH4: 5:2 Cond i	ATC 2.62 mS/cm	
CH5: 6:1 Chlorine	28.33 mg/l	
CH6: 6:2 Redox	± 51 mV	
CH7: 7:1 Oxygen (am...)	32.86 mg/l	
CH8: 7:2 Cond c	ATC 131.1 pS/cm	
MENU	CAL	DIAG
		HOLD

5 Slot and port assignment on the display

- Inputs are assigned to measuring channels in the ascending order of the slots and ports. Adjacent example: "CH1: 1:1 pH glass" means: Channel 1 (CH1) is slot 1 (basic module) : Port 1 (input 1), pH glass sensor
- Outputs and relays are named according to their function, e.g. "current output", and are displayed with the slot and port numbers in ascending order

### Order of the modules

Depending on the version ordered, the device is supplied with a number of electronic modules, which are assigned in a specific sequence in ascending order to slots 0 to 7. If you do not have a particular module, the next moves up automatically:

- The basic module (which is always present) always occupies slots 0 and 1
- Fieldbus module 485 or Ethernet module ETH (only one of the two modules can be used)
- Photometer module PEM
- Memosens input module 2DS (DS = digital sensor)
- Extension module for digital inputs and outputs DIO (DIO = digital input and output)
- Current input module 2AI (AI = analog input)
- Current output module 4AO or 2AO (AO = analog output)
- Relay modules AOR, 4R or 2R (AOR = analog output + relay, R = relay)



Modules with 4 ports are connected before modules of the same type with 2 ports.

### Basic rule for hardware upgrades



Please note the following if upgrading the device:

- The sum of all current inputs and outputs may not exceed 8!
- A maximum of two "DIO" modules may be used.

### Determining the hardware delivery status

You must be aware of the type of modules and the number of them supplied with the device you have ordered to determine the delivery status of your Liquiline.

- **Basic module**  
One basic module in all versions. Always occupies slots 0 and 1.
- **Fieldbus module**  
Optional, and only one fieldbus module is possible.
- **Input modules**
  - Must be clearly assigned to the number of optional inputs ordered.
  - Examples:
    - 2 current inputs = module 2AI
    - 2 inputs for photometer sensors = module PEM
    - 4 Memosens inputs = 2 inputs with basic module + module 2DS with 2 further inputs
- **Current outputs and relays**  
Various module combinations can exist.  
The following table will help you determine which modules your device has, depending on the type and number of outputs.

Current outputs	Relays		
	0	2	4
2	-	1 x 2R	1 x 4R
4	1 x 2AO	1 x AOR	1 x 2AO + 1 x 4R
6	1 x 4AO	1 x 4AO + 1 x 2R	1 x 4AO + 1 x 4R
8	1 x 4AO + 1 x 2AO	1 x 4AO + 1 x 2AO + 1 x 2R	1 x 4AO + 1 x 2AO + 1 x 4R

- ▶ Sum up the number of modules and sort them according to the specified sequence → 7.
  - ↳ This will give you the slot assignment for your device.

### Terminal diagram

**i** The unique terminal name is derived from:

Slot no. : Port no. : Terminal

#### Example, NO contact of a relay

Device with 2 inputs for digital sensors, 4 current outputs and 4 relays

- Base module BASE-E (contains 2 sensor inputs, 2 current outputs)
- PEM module (1 photometer sensor)
- 2AO module (2 current outputs)
- 4R module (4 relays)

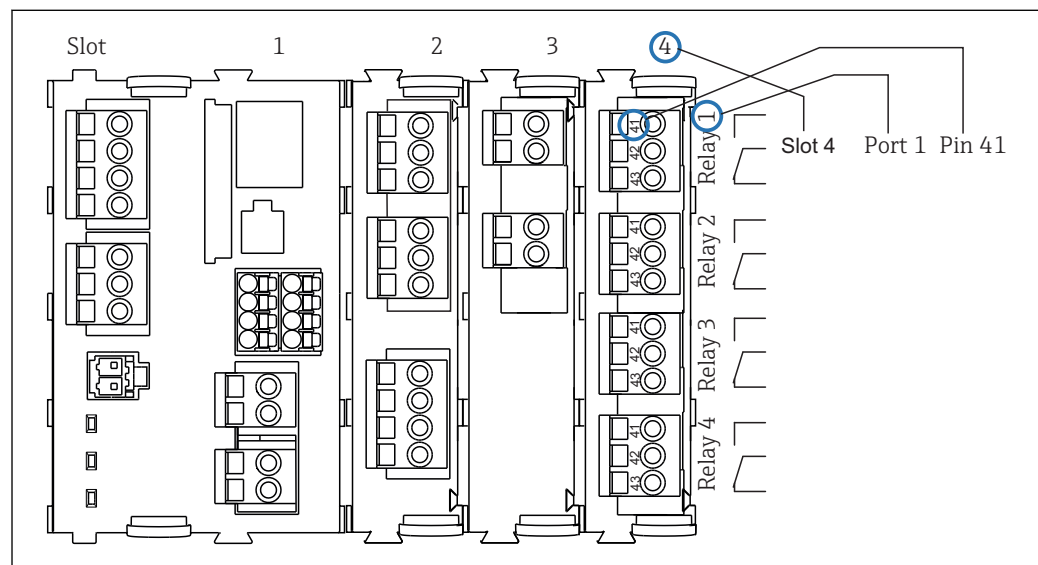

6 Creating a terminal diagram using the example of the NO contact (terminal 41) of a relay

A0028206



Device configuration using the example of a CM44P-\*\*

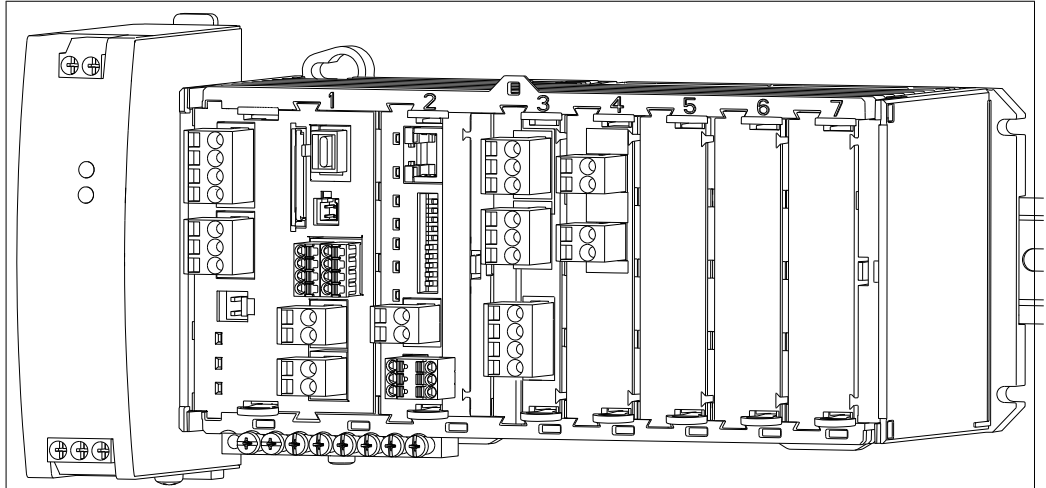

<p><b>Ordered basic device (example)</b></p>	<ul style="list-style-type: none"> <li>■ CM44P-**DINP1M22A1FA*(cabinet device)</li> <li>■ Functionality:             <ul style="list-style-type: none"> <li>- 1x photometer (module PEM)</li> <li>- 2x Memosens (module BASE-E)</li> <li>- PROFIBUS communication (module 485)</li> <li>- 2 current outputs without HART (on BASE-E module)</li> <li>- 2 current inputs (module AI)</li> </ul> </li> </ul> <p>3 slots are still free in this example. More or fewer slots can be free in other versions.</p>
<p><b>Extension options without additional modules</b></p>	<p>None</p>
<p><b>Modification options without additional modules</b></p>	<ul style="list-style-type: none"> <li>■ Communication type changed by entering activation code. This disables the communication type used previously!             <ul style="list-style-type: none"> <li>- Modbus RS485 (71140889)</li> <li>- Modbus TCP (71140890)</li> <li>- EtherNet/IP (71219868)</li> </ul> </li> <li>■ Retrofit to HART by removing module 485 and entering activation code for HART (71128428)</li> </ul>
<p><b>Extension options by using extension modules in free slots 5-7</b></p>	<p>Only the following is possible for the example above:</p> <ul style="list-style-type: none"> <li>■ Module 2R (71125375) or 4R (71125376): 2 or 4 relays</li> <li>■ Module DIO (71135638): 2 digital inputs and 2 digital outputs</li> </ul> <p>If extended to four Memosens channels:</p> <ul style="list-style-type: none"> <li>■ Module 2DS (71135631): 2 Memosens inputs</li> <li>■ Use of the 2 current outputs in the basic module by entering activation code (71140891)</li> </ul> <p>Additional inputs or outputs and relays if fieldbus module 485 is removed:</p> <ul style="list-style-type: none"> <li>■ Module 2AO (71135632): 2 current outputs</li> <li>■ Module AOR (71111053): 2 current outputs, 2 relays</li> <li>■ Module 2R (71125375) or 4R (71125376): 2 or 4 relays</li> </ul> <p><b>i</b> If you replace module 485 with ETH, you can operate up to 6 current outputs in addition to the ETH module's ethernet or Modbus function. Only two current outputs are possible with 485.</p>
<p><b>Basic rule for extensions</b></p>	<p>The sum of all current inputs and outputs may not exceed 8!</p>
<p><b>Restrictions if using CUS71D sensors for interface measurement</b></p>	<p>If CUS71D sensors are used, the maximum number of Memosens inputs is limited to two. Any combination of CUS71D or other sensors is possible.</p>
<p><b>Product Configurator</b></p>	<p><a href="http://www.endress.com/cm44p">www.endress.com/cm44p</a></p>

Block circuit diagram of CM44P-\*\*

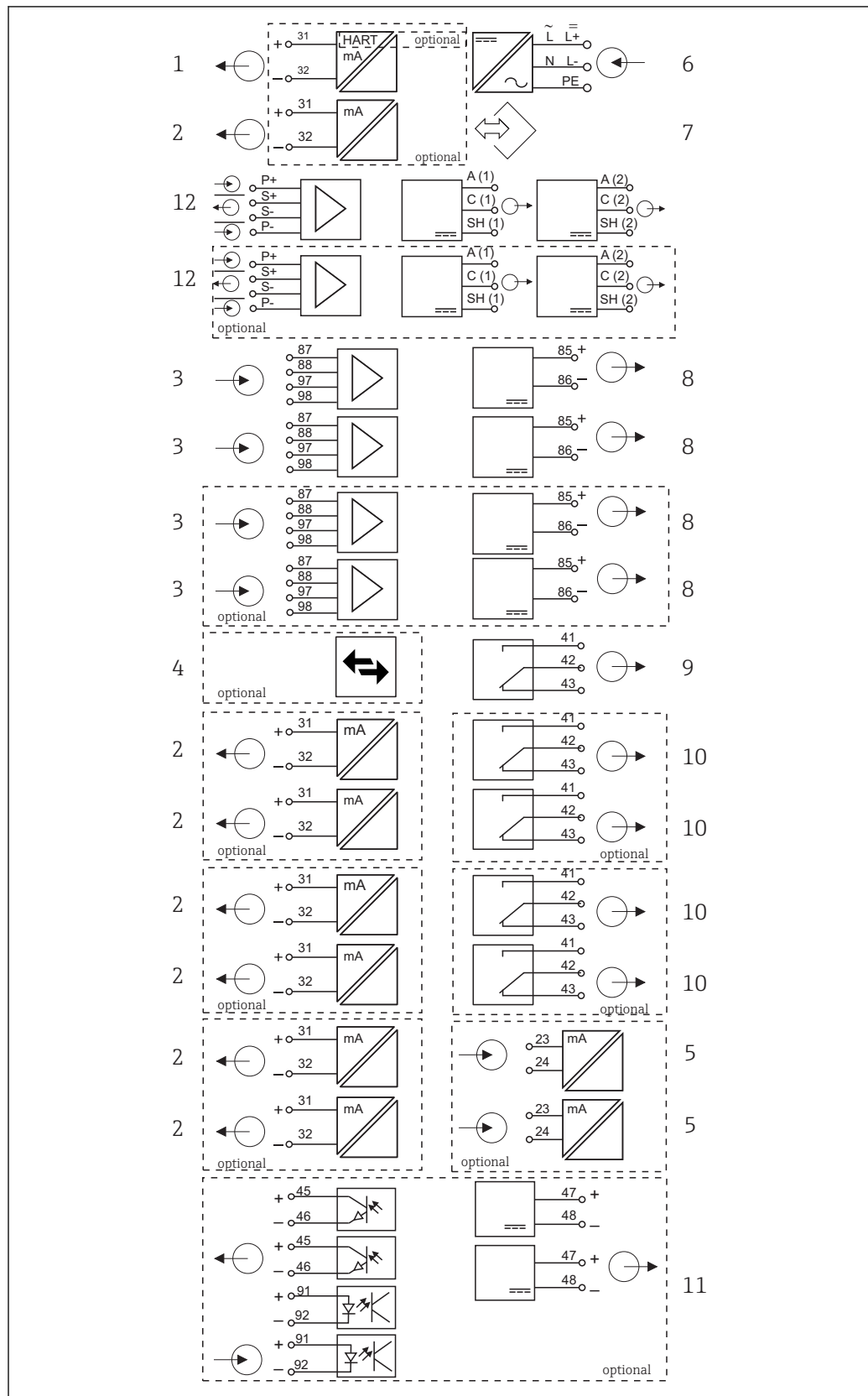

A0029203

7 Block circuit diagram of CM444 P

- |   |  |    |  |
|---|--|----|--|
| 1 | Current output 1:1, + HART (both optional)   | 7  | Service interface                        |
| 2 | Max. 7 x current output (optional)           | 8  | Power supply, fixed cable sensors        |
| 3 | Memosens input (2 x standard + 2 x optional) | 9  | Alarm relay                              |
| 4 | PROFIBUS DP/Modbus/Ethernet (optional)       | 10 | 2 or 4 x relays (optional)               |
| 5 | 2 x current input (optional)                 | 11 | 2 digital inputs and outputs (optional)  |
| 6 | Power supply                                 | 12 | Photometer: 2x lamp voltage and detector |

## Communication and data processing

### Types of communication:

- Fieldbuses
  - HART
  - PROFIBUS DP (Profile 3.02)
  - Modbus TCP or RS485
- EtherNet/IP



Only one type of Fieldbus communication can ever be active. The last activation code entered decides which bus is used.

The device drivers available make it possible to perform a basic setup and display measured values and diagnostics information via the fieldbus. A full device configuration via the fieldbus is not possible.

### Extension module 485 and current outputs

For PROFIBUS DP, Modbus and Ethernet communication protocols:

A maximum of 2 current outputs can be used in parallel.

### Extension module ETH and current outputs

- Communication via Ethernet or EtherNet/IP
- A maximum of 6 current outputs can be used in parallel.

### Bus termination on the device

- Via slide switch at bus module 485
- Displayed via LED "T" on bus module 485

## Dependability

### Reliability

#### Memosens

Memosens makes your measuring point safer and more reliable:

- Non-contact, digital signal transmission enables optimum galvanic isolation
- No contact corrosion
- Completely watertight
- Sensor can be calibrated in a lab, thus increasing the availability of the measuring point in the process
- Intrinsically safe electronics mean operation in hazardous areas is not a problem.
- Predictive maintenance thanks to recording of sensor data, e.g.:
  - Total hours of operation
  - Hours of operation with very high or very low measured values
  - Hours of operation at high temperatures
  - Number of steam sterilizations
  - Sensor condition

#### Heartbeat diagnostics

- Heartbeat diagnostics screen with graphic indicators for the health of the device and sensor and with a maintenance or (sensor-dependent) calibration timer
- Heartbeat status information on the health of the device and the condition of the sensor
  - ☹: Sensor/device condition or maintenance timer > 20 %; no action is required
  - 😐: Sensor/device condition or maintenance timer > 5 ≤ 20 %, maintenance not yet urgent but should be scheduled
  - 😊: Sensor/device condition or maintenance timer < 5 %, maintenance is recommended
- The Heartbeat sensor condition is the assessment of the calibration results and the sensor diagnostic functions.

An unhappy smiley can be due to the calibration result, the measured value status or to the operating hours limit having been exceeded. These limits can be configured in the sensor setup in a way that adapts the Heartbeat diagnostics to the application.

### Heartbeat and NAMUR category

The Heartbeat status indicates the sensor or device condition while the NAMUR categories (F, C, M, S) assess the reliability of the measured value. The two conditions can correlate but do not have to.

#### ■ Example 1

- The number of remaining cleaning cycles for the sensor reaches 20% of the defined maximum number. The Heartbeat symbol changes from ☺ to ☹. The measured value is still reliable so the NAMUR status signal does not change.
- If the maximum number of cleaning cycles is exceeded, the Heartbeat symbol changes from ☹ to ☹. While the measured value can still be reliable, the NAMUR status signal changes to M (maintenance required).

#### ■ Example 2

The sensor breaks. The Heartbeat status changes immediately from ☺ to ☹ and the NAMUR status signal also changes immediately to F (failure).

### Heartbeat Monitoring

Sensor data from Memosens sensors are transmitted via the EtherNet/IP and Modbus TCP fieldbus protocols. These data can be used for predictive maintenance, for instance.

Examples include:

- Total hours of operation
- Hours of operation with very high or very low measured values
- Hours of operation at high temperatures
- Number of steam sterilizations
- Sensor identification
- Calibration information



SD EtherNet/IP and Modbus

### Heartbeat Verification

Heartbeat Verification makes it possible to verify the correct operation of the measuring device without interrupting the process. This verification can be documented anytime.

### Sensor Check System (SCS)

The Sensor Check System (SCS) monitors the high impedance of the pH glass. An alarm is issued if a minimum impedance value is undershot or a maximum impedance is exceeded.

- Glass breakage is the main reason for a drop in high impedance values
- The reasons for increasing impedance values include:
  - Dry sensor
  - Worn pH glass membrane

### Process Check System (PCS)

The process check system (PCS) checks the measuring signal for stagnation. An alarm is triggered if the measuring signal does not change over a specific period (several measured values).

The main causes of stagnating measured values are:

- Contaminated sensor, or sensor outside of medium
- Sensor defective
- Process error (e.g. through control system)

### Self-monitoring functions

Current inputs are deactivated in the event of overcurrent and reactivated once the overcurrent stops. Board voltages are monitored and the board temperature is also measured.

### USP and EP

The limit functions for pharmaceutical water in accordance with USP and EP specifications are implemented in the software for conductivity measurements:

- "Water for Injection" (WFI) as per USP <645> and EP
- "Highly Purified Water" (HPW) as per EP
- "Purified Water" (PW) as per EP

The uncompensated conductivity value and the temperature are measured for the USP/EP limit functions. The measured values are compared against the tables defined in the standards. An alarm is triggered if the limit value is exceeded. Furthermore, it is also possible to configure an early warning alarm that signals undesired operating states before they occur.

### ChemocleanPlus

Freely programmable sequence control

- e.g. for automatic sensor cleaning in retractable assemblies for reliable measurement results in processes with a high risk of contamination
- Individual, time-based activation of 4 outputs e.g. relays
- Starting, stopping or pausing of activities via digital input or fieldbus signals e.g. from limit position switches

### Maintainability

#### Modular design

The modular transmitter design means it can be easily adapted to suit your needs:

- Retrofit extension modules for new or extended range of functions, e.g. current outputs, relays and digital communication
- Upgrade to maximum 2 photometers and 4 Memosens inputs
- Optional: M12 sensor connector for connecting any kind of Memosens sensor
- Optional: CDI connector for external access to the service interface (avoids having to unscrew the housing cover)

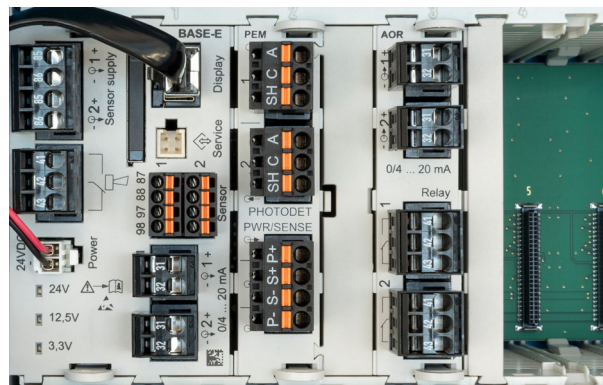

A00342B2

8 CM44P: example

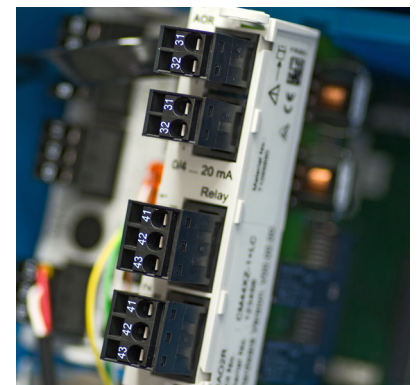

A0012440

9 Extension module

### Data logger function

- Adjustable scan time: 1 to 3600 s (1 h)
- Data logbooks:
  - Max. 8 data logbooks
  - 150,000 entries per logbook
  - Graphic display (load curves) or numerical list
- Calibration logbook: max. 75 entries
- Hardware version logbook:
  - Hardware configuration and modifications
  - Max. 125 entries
- Version logbook:
  - E.g. software updates
  - Max. 50 entries
- Operation logbook: max. 250 entries
- Diagnostics logbook: max. 250 entries

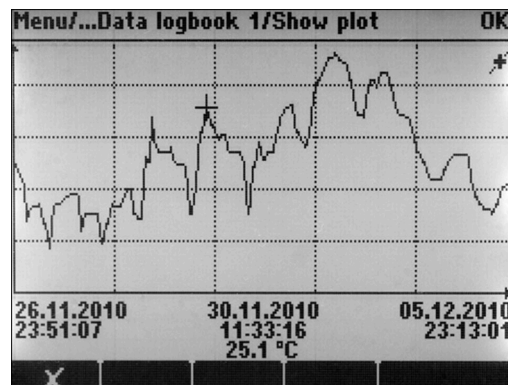

A0015032

 10 Data logbook: Graphic display

 Logbooks remain unchanged even after a software update.

### SD card

The exchangeable storage medium enables:

- Quick and easy software updates and upgrades
- Data storage of internal device memory (e.g. logbooks)
- Transfer of complete configurations to a device with an identical setup (backup function)
- Transfer of configurations without the TAG and bus address to devices with an identical setup (copy function)
- Saving of screenshots for documentation purposes

Endress+Hauser offers industry-approved SD cards as accessories. These memory cards provide maximum data security and integrity.

Other SD cards up to a maximum weight of 5 g can also be used. However, Endress+Hauser does not accept any responsibility for the data security of such cards.

### External signals for device control and for activating external devices

Hardware options, e.g. module "DIO" with 2 digital inputs and 2 digital outputs or fieldbus module "485" enable the following:

- via a digital input signal
  - measuring range switching for conductivity (upgrade code required, see accessories)
  - switching between different calibration datasets in the case of optical sensors
  - an external hold
  - a cleaning interval to be triggered
  - switching on and off a PID controller, e.g. via the proximity switch of the CCA250
  - the use of the input as an "analog input" for pulse-frequency modulation (PFM)
- via a digital output signal
  - the static transmission (similar to a relay) of diagnostic states, point level switch states etc.
  - the dynamic transmission (comparable to a non-wearing "analog output") of PFM signals, e.g. to control dosing pumps.

## FieldCare and Field Data Manager

### FieldCare

Configuration and asset management software based on FDT/DTM technology

- Complete device configuration when connected via FXA291 and service interface
- Access to a number of configuration parameters and identification, measuring and diagnostic data when connected via HART modem
- Logbooks can be downloaded in CSV format or binary format for "Field Data Manager" software

### Field Data Manager

Visualization software and database for measuring, calibration and configuration data

- SQL database which is protected against manipulation
- Functions to import, save and print out logbooks
- Load curves to display measured values

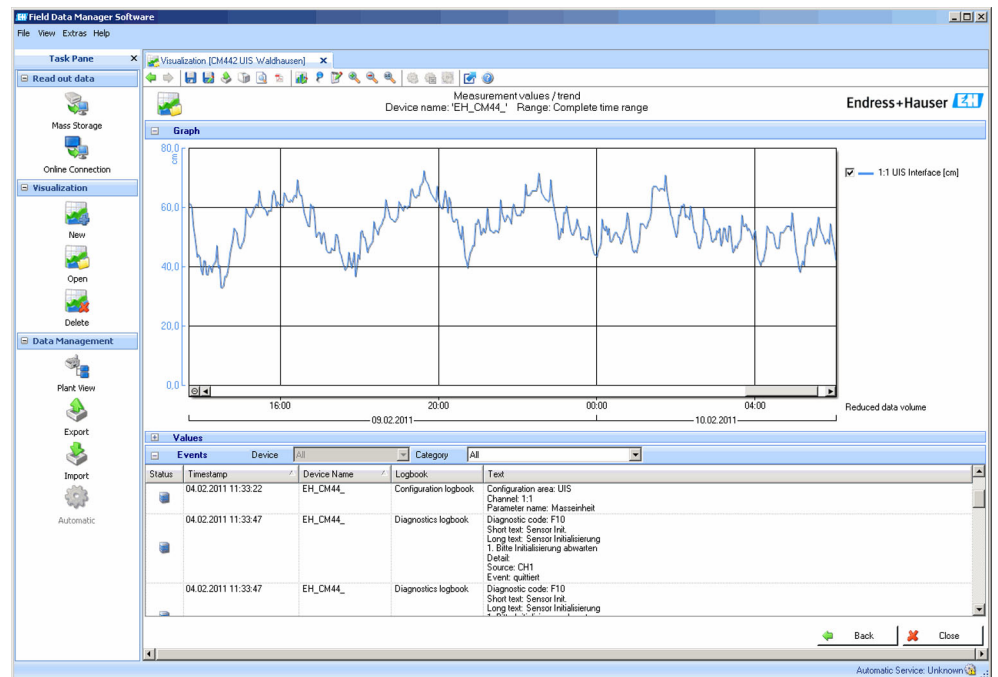

11 Field Data Manager: Load curves

### Virtual process values (mathematical functions)

In addition to "real" process values, which are provided by connected physical sensors or analog inputs, mathematical functions can be used to calculate a maximum of 6 "virtual" process values.

The "virtual" process values can be:

- Output via a current output or a fieldbus
- Used as a controlled variable
- Assigned as a measured variable to a limit switch
- Used as a measured variable to trigger cleaning
- Displayed in user-defined measuring menus

The following mathematical functions are possible:

- Calculation of pH from two conductivity values according to VGB 405 RL, e. g. in boiler feedwater
- Difference between two measured values from different sources, e. g. for membrane monitoring
- Differential conductivity, e. g. for monitoring the efficiency of ion exchangers
- Degassed conductivity, e. g. for process controls in power plants
- Redundancy for monitoring two or three redundant sensors
- rH calculation based on the measured values of a pH and an ORP sensor
- Calculation of the remaining capacity of a cation exchanger
- Formula editor

### Concentration tables

When the device is delivered from the factory, tables are saved in the device that allow inductive conductivity measurements to be converted to concentrations of certain substances. 4 user-defined tables are also possible.

*The following factory concentration tables are available:*

NaOH	0 to 15 %	0 to 100 °C (32 to 212 °F)
NaOH	25 to 50%	2 to 80 °C (36 to 176 °F)
HCl	0 to 20 %	0 to 65 °C (32 to 149 °F)
HNO <sub>3</sub>	0 to 30 %	2 to 80 °C (36 to 176 °F)
H <sub>2</sub> SO <sub>4</sub>	0.5 to 27 % and 35 to 85 %	0 to 100 °C (32 to 212 °F)
H <sub>2</sub> SO <sub>4</sub>	93 to 100 %	10 to 115 °C (50 to 239 °F)
H <sub>3</sub> PO <sub>4</sub>	0 to 40 %	2 to 80 °C (36 to 176 °F)
NaCl	0 to 26 %	2 to 80 °C (36 to 176 °F)

## Safety

### Real-time clock

The device has a real-time clock, which is buffered by a button cell battery if the power supply fails.

This ensures that the device continues to keep the correct date and time when it is restarted and that the time stamp for the logbooks is correct.

### Data security

All settings, logbooks etc. are stored in a non-volatile memory to ensure that the data are retained even in the event of a disruption to the power supply.

### Measuring range switching for conductivity

- Can be used in CIP processes e.g. for safe monitoring of phase separations
- Switching between 4 complete parameter sets:
  - Conductivity operating mode
  - Concentration tables
  - Temperature compensation
  - Output signal range
  - Limit value switch
- Via digital inputs or fieldbus

### Measured value compensation for oxygen and conductivity

- Pressure or temperature compensation
- Input signals from external sensors via current input or fieldbus
- Signals from connected temperature sensors

### Password protection

Password-protected login

- For remote operation via web server
- For local operation

### Process safety

Two independent PID controllers

- One- or two-sided control
- Limit switches
- 4 cleaning programs which can be programmed independently of each other

### IT security

Our warranty is valid only if the device is installed and used as described in the Operating Instructions. The device is equipped with security mechanisms to protect it against any inadvertent changes to the settings.

IT security measures, which provide additional protection for the device and associated data transfer, must be implemented by the operators themselves in line with their security standards.



## Input

<b>Measured variables</b>	<p><b>Photometer</b></p> <ul style="list-style-type: none"> <li>▪ Absorption (UV, color, NIR, cell growth)</li> <li>▪ Turbidity</li> </ul> <p><b>Memosens sensors</b></p> <p>→ Documentation of the connected sensor</p>
<b>Measuring ranges</b>	<p><b>Photometer</b></p> <p>OUSAF12, OUSAF21, OUSAF22, OUSAF44, OUSAF46</p> <ul style="list-style-type: none"> <li>▪ 0 to 2.5 AU</li> <li>▪ Max. 50 OD (depending on the optical path length)</li> </ul> <p>OUSAF11</p> <ul style="list-style-type: none"> <li>▪ 0 to 3 AU</li> <li>▪ 0 to 6 OD (depending on the optical path length)</li> </ul> <p>OUSTF10</p> <ul style="list-style-type: none"> <li>▪ 0 to 200 FTU</li> <li>▪ 0 to 200 ppm DE</li> </ul> <p>OUSBT66</p> <ul style="list-style-type: none"> <li>▪ 0 to 4 AU</li> <li>▪ 0 to 8 OD (depending on the optical path length)</li> </ul> <p><b>Memosens sensors</b></p> <p>→ Documentation of the connected sensor</p>
<b>Types of input</b>	<ul style="list-style-type: none"> <li>▪ Digital sensor inputs for sensors with Memosens protocol</li> <li>▪ Analog current inputs (optional)</li> <li>▪ Digital inputs (optional)</li> <li>▪ Analog photometer inputs</li> </ul>
<b>Input signal</b>	<p>Depending on version:</p> <ul style="list-style-type: none"> <li>▪ Max. 2 x analog photometers</li> <li>▪ Max. 4 x binary sensor signal</li> <li>▪ 2 x 0/4 to 20 mA (optional), passive, potentially isolated from one another and from the sensor inputs</li> <li>▪ 0 to 30 V</li> </ul>
<b>Cable specification</b>	<p><b>Cable type</b></p> <ul style="list-style-type: none"> <li>▪ Cable set CUK80 for photometer sensors</li> <li>▪ Memosens data cable CYK10 or sensor fixed cable, each with cable end sleeves or M12 round-pin connector (optional, for field housing)</li> </ul> <p><b>Cable length</b></p> <p><i>All sensors except OUSBT66</i></p> <p>Max. 100 m (330 ft)</p> <p><i>OUSBT66</i></p> <p>Maximum 20 m (65 ft)</p>

## Digital inputs, passive

<b>Electrical specification</b>	<ul style="list-style-type: none"> <li>▪ drawing power (passive)</li> <li>▪ Galvanically isolated</li> </ul>
<b>Span</b>	<ul style="list-style-type: none"> <li>▪ High: 11 to 30 V DC</li> <li>▪ Low: 0 to 5 V DC</li> </ul>

Nominal input current	max. 8 mA
PFM function	Minimum pulse width: 500 $\mu$ s (1 kHz)
Test voltage	500 V
Cable specification	Max. 2.5 mm <sup>2</sup> (14 AWG)

## Current input, passive

Span	> 0 to 20 mA
Signal characteristic	Linear
Internal resistance	Non-linear
Test voltage	500 V

## Output

### Output signal

Depending on version:

- 2 x 0/4 to 20 mA, active, galvanically isolated from one another and from the sensor circuits
- 4 x 0/4 to 20 mA, active, galvanically isolated from one another and from the sensor circuits
- 6 x 0/4 to 20 mA, active, galvanically isolated from one another and from the sensor circuits
- 8 x 0/4 to 20 mA, active, galvanically isolated from one another and from the sensor circuits
- Optional HART communication (only via current output 1:1)

HART	
Signal encoding	FSK $\pm$ 0.5 mA above current signal
Data transmission rate	1200 baud
Galvanic isolation	Yes
Load (communication resistor)	250 $\Omega$

PROFIBUS DP/RS485	
Signal encoding	EIA/TIA-485, PROFIBUS DP-compliant acc. to IEC 61158
Data transmission rate	9.6 kBd, 19.2 kBd, 45.45kBd, 93.75 kBd, 187.5 kBd, 500 kBd, 1.5 MBd, 6 MBd, 12 MBd
Galvanic isolation	Yes
Connectors	Spring terminal (max. 1.5 mm), bridged internally (T-function), optional M12
Bus termination	Internal slide switch with LED display

Modbus RS485	
Signal encoding	EIA/TIA-485
Data transmission rate	2,400, 4,800, 9,600, 19,200, 38,400, 57,600 and 115,200 baud
Galvanic isolation	Yes
Connectors	Spring terminal (max. 1.5 mm), bridged internally (T-function), optional M12
Bus termination	Internal slide switch with LED display

Ethernet and Modbus TCP	
Signal encoding	IEEE 802.3 (Ethernet)
Data transmission rate	10/100 MBd
Galvanic isolation	Yes
Connection	RJ45
IP address	DHCP (default) or configuration via menu

EtherNet/IP	
Signal encoding	IEEE 802.3 (Ethernet)
Data transmission rate	10/100 MBd
Galvanic isolation	Yes
Connection	RJ45
IP address	DHCP (default) or configuration via menu

<b>Signal on alarm</b>	Adjustable, as per NAMUR Recommendation NE 43 <ul style="list-style-type: none"> <li>■ In measuring range 0 to 20 mA (HART is not available with this measuring range): Failure current from 0 to 23 mA</li> <li>■ In measuring range 4 to 20 mA: Failure current from 2.4 to 23 mA</li> <li>■ Factory setting for failure current for both measuring ranges: 21.5 mA</li> </ul>
------------------------	--

<b>Load</b>	Max. 500 Ω
-------------	------------

<b>Linearization/transmission behavior</b>	Linear
--	--------

## Digital outputs, passive

<b>Electrical specification</b>	<ul style="list-style-type: none"> <li>■ Passive</li> <li>■ Open collector, max. 30 V, 15 mA</li> <li>■ Maximum voltage drop 3 V</li> </ul>
---------------------------------	---

<b>External power supply</b>	When using an onsite auxiliary voltage supply and an onsite digital input: Recommended minimum auxiliary voltage = $3\text{ V} + V_{IHmin}$ ( $V_{IHmin}$ = minimum input voltage required (high-level input voltage))
------------------------------	--

<b>PFM function</b>	Minimum pulse width: 500 μs (1 kHz)
---------------------	-------------------------------------

<b>Auxiliary voltage</b>	<b>Electrical specification</b> <ul style="list-style-type: none"> <li>▪ Galvanically isolated</li> <li>▪ Unregulated, 24 V DC</li> <li>▪ Max. 50 mA (per DIO module)</li> </ul>
<b>Test voltage</b>	500 V
<b>Cable specification</b>	Max. 2.5 mm <sup>2</sup> (14 AWG)

## Current outputs, active

<b>Span</b>	0 to 23 mA 2.4 to 23 mA for HART communication
-------------	---

<b>Signal characteristic</b>	Linear
------------------------------	--------

<b>Electrical specification</b>	<b>Output voltage</b> Max. 24 V  <b>Test voltage</b> 500 V
---------------------------------	--

<b>Cable specification</b>	<b>Cable type</b> Recommended: shielded cable  <b>Cable specification</b> Max. 2.5 mm <sup>2</sup> (14 AWG)
----------------------------	---

## Relay outputs

<b>Electrical specification</b>	<b>Relay types</b> <ul style="list-style-type: none"> <li>▪ 1 single-pin changeover contact (alarm relay)</li> <li>▪ 2 or 4 single-pin changeover contacts (optional with extension modules)</li> </ul> <b>Maximum load</b> <ul style="list-style-type: none"> <li>▪ Alarm relay: 0.5 A</li> <li>▪ All other relays: 2.0 A</li> </ul> <b>Relay switching capacity</b>
---------------------------------	---

*Base module (Alarm relay)*

Switching voltage	Load (max.)	Switching cycles (min.)
230 V AC, $\cos\Phi = 0.8$ to 1	0.1 A	700,000
	0.5 A	450,000
115 V AC, $\cos\Phi = 0.8$ to 1	0.1 A	1,000,000
	0.5 A	650,000
24 V DC, L/R = 0 to 1 ms	0.1 A	500,000
	0.5 A	350,000

*Extension modules*

Switching voltage	Load (max.)	Switching cycles (min.)
230 V AC, $\cos\Phi = 0.8$ to 1	0.1 A	700,000
	0.5 A	450,000
	2 A	120,000
115 V AC, $\cos\Phi = 0.8$ to 1	0.1 A	1,000,000
	0.5 A	650,000
	2 A	170,000
24 V DC, L/R = 0 to 1 ms	0.1 A	500,000
	0.5 A	350,000
	2 A	150,000

**Cable specification**Max. 2.5 mm<sup>2</sup> (14 AWG)**Protocol-specific data****HART**

Manufacturer ID	11 <sub>h</sub>
Device type	155D <sub>h</sub>
Device revision	001 <sub>h</sub>
HART version	7.2
Device description files (DD/DTM)	<a href="http://www.endress.com/hart">www.endress.com/hart</a> Device Integration Manager DIM
Device variables	16 user-definable and 16 predefined device variables, dynamic variables PV, SV, TV, QV
Supported features	PDM DD, AMS DD, DTM, Field Xpert DD

**PROFIBUS DP**

Manufacturer ID	11 <sub>h</sub>
Device type	155D <sub>h</sub>
Profile version	3.02
GSD files	<a href="http://www.endress.com/profibus">www.endress.com/profibus</a> Device Integration Manager DIM
Output values	16 AI blocks, 8 DI blocks
Input variables	4 AO blocks, 8 DO blocks
Supported features	<ul style="list-style-type: none"> <li>▪ 1 MSCY0 connection (cyclical communication, master class 1 to slave)</li> <li>▪ 1 MSAC1 connection (acyclical communication, master class 1 to slave)</li> <li>▪ 2 MSAC2 connections (acyclical communication, master class 2 to slave)</li> <li>▪ Device lock: The device can be locked using the hardware or software.</li> <li>▪ Addressing using DIL switches or software</li> <li>▪ GSD, PDM DD, DTM</li> </ul>

**Modbus RS485**

Protocol	RTU/ASCII
Function codes	03, 04, 06, 08, 16, 23
Broadcast support for function codes	06, 16, 23
Output data	16 measured values (value, unit, status), 8 digital values (value, status)
Input data	4 setpoints (value, unit, status), 8 digital values (value, status), diagnostic information
Supported features	Address can be configured using switch or software

**Modbus TCP**

TCP port	502
TCP connections	3
Protocol	TCP
Function codes	03, 04, 06, 08, 16, 23
Broadcast support for function codes	06, 16, 23
Output data	16 measured values (value, unit, status), 8 digital values (value, status)
Input data	4 setpoints (value, unit, status), 8 digital values (value, status), diagnostic information
Supported features	Address can be configured using DHCP or software

**EtherNet/IP**

Log	EtherNet/IP	
ODVA certification	Yes	
Device profile	Generic device (product type: 0x2B)	
Manufacturer ID	0x049E <sub>h</sub>	
Device type ID	0x109C <sub>h</sub>	
Polarity	Auto-MIDI-X	
Connections	CIP	12
	I/O	6
	Explicit message	6
	Multicast	3 consumers
Minimum RPI	100 ms (default)	
Maximum RPI	10000 ms	
System integration	EtherNet/IP	EDS
	Rockwell	Add-on-Profile Level 3, Faceplate for Factory Talk SE
IO data	Input (T → O)	Device status and diagnostic message with highest priority Measured values: <ul style="list-style-type: none"> <li>▪ 16 AI (analog input) + Status + Unit</li> <li>▪ 8 DI (discrete input) + Status</li> </ul>
	Output (O → T)	Actuating values: <ul style="list-style-type: none"> <li>▪ 4 AO (analog output) + status + unit</li> <li>▪ 8 DO (discrete output) + Status</li> </ul>

**Web server**

The Web server enables full access to the device configuration, measured values, diagnostic messages, logbooks and service data via standard WiFi/WLAN/LAN/GSM or 3G routers with a user-defined IP address.

TCP port	80
Supported features	<ul style="list-style-type: none"> <li>▪ Remote-controlled device configuration(1 session)</li> <li>▪ Save/restore device configuration (via SD card)</li> <li>▪ Logbook export (file formats: CSV, FDM)</li> <li>▪ Access to Web server via DTM or Internet Explorer</li> <li>▪ Login</li> <li>▪ Web server can be switched off</li> </ul>

## Power supply

**Supply voltage**

**CM44P**

Depending on the version,:

- 100 to 230 V AC, 50/60 Hz  
Maximum permitted fluctuation of mains supply voltage:  $\pm 15\%$  of nominal voltage <sup>1)</sup>
- 24 V DC  
Maximum permitted fluctuation of mains supply voltage:  $+ 20\% / - 15\%$  of nominal voltage <sup>1)</sup>

**NOTICE**

**The device does not have a power switch!**

- ▶ Provide a protected circuit breaker in the vicinity of the device at the place of installation.
- ▶ The circuit breaker must be a switch or power switch, and must be labeled as the circuit breaker for the device.
- ▶ At the supply point, the power supply must be isolated from dangerous live cables by double or reinforced insulation in the case of devices with a 24 V supply voltage.

**Power consumption**

**CM44P**

Depending on supply voltage

- 100 to 230 V AC:  
Max. 73 VA (field device)  
Max. 150 VA (cabinet device)
- 24 V DC:  
Max. 68 W (field device)  
Max. 59 W (cabinet device)

**Fuse**

Fuse not exchangeable

**Overvoltage protection**

Integrated overvoltage/lightning protection as per EN 61326  
Protection category 1 and 3

---

1) \*Specifications only apply if used with power unit supplied by manufacturer.

**Cable entries (field device only)**

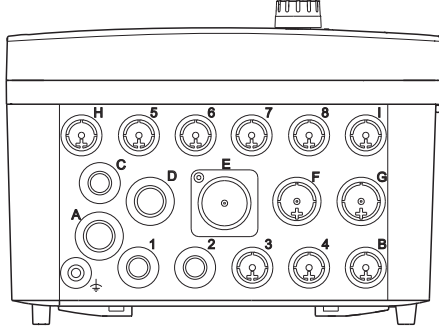
Identification of the cable entry on housing base	Suitable gland
B, C, H, I, 1-8	M16x1.5 mm/NPT3/8"/G3/8
A, D, F, G	M20x1.5 mm/NPT1/2"/G1/2
E	-
≡	M12x1.5 mm
	<p><b>Recommended assignment</b></p> <p>1-8      Sensors 1-8                      A        Power supply                      B        RS485 In or M12 DP/RS485                      C        Can be used freely                      D,F,G    Current outputs and inputs, relays                      H        Can be used freely                      I        RS485 Out or M12 Ethernet                      E        Do not use</p>

**Cable specification**

**Length of display cable provided (cabinet device only):**

3 m (10 ft)

**Maximum permitted length of a display cable (cabinet device only):**

5 m (16.5 ft)

**Electrical connection**

**Connecting supply voltage**

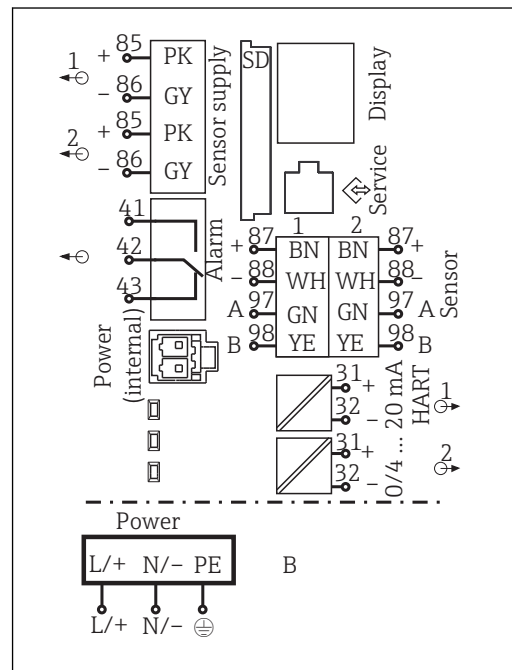
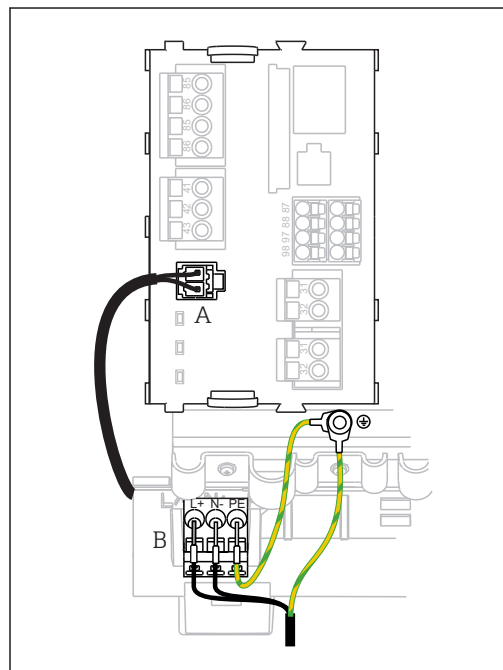

12 Power supply connection on the BASE-E (field device)

13 Overall wiring diagram BASE-E and extension power unit (B)

- A Internal power supply cable
- B Extension power unit



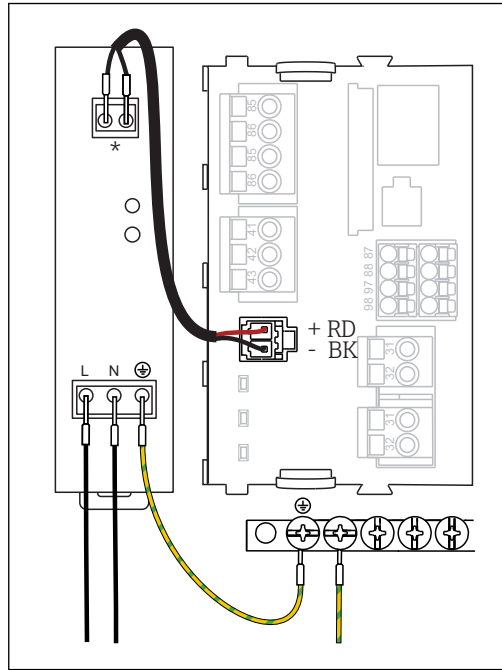

14 Power supply connection with BASE-E (cabinet device)

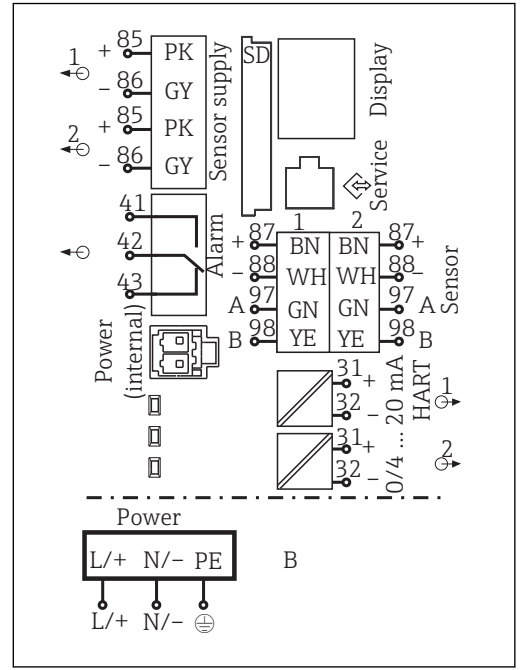

15 Overall wiring diagram BASE-E and external power unit (B)

\* Assignment depending on power unit, make sure to connect correctly

**i** The two device versions may only be operated with the power unit supplied and the power unit cable. Also pay attention to the information in the operating manual supplied for the power unit.

**Connecting optional modules** With extension modules you can purchase additional functions for your device.

**NOTICE**

**Unacceptable hardware combinations (due to conflicts in power supply)**

Incorrect measurements or total failure of the measuring point as a result of heat build-up or overloading

- ▶ If you are planning to extend your controller, make sure the resulting hardware combination is permitted (Configurator at [www.endress.com](http://www.endress.com)).
- ▶ Remember that the sum of all current inputs and outputs may not exceed 8.
- ▶ Make sure not to use more than 2 "DIO" modules. More "DIO" modules are not permitted.
- ▶ Please contact your Endress+Hauser sales center should you have any questions.

Overview of all the modules available

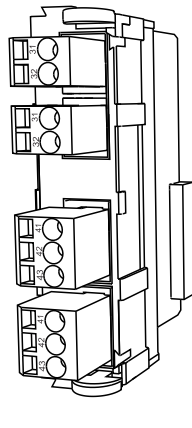
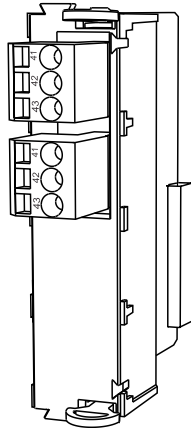
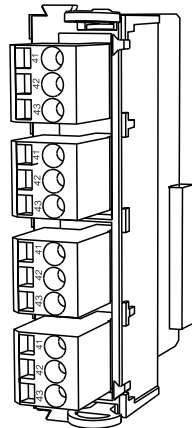
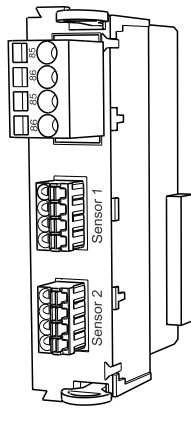
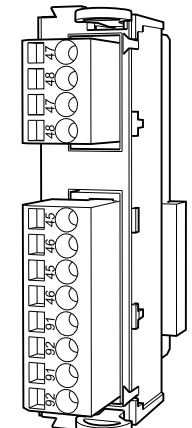
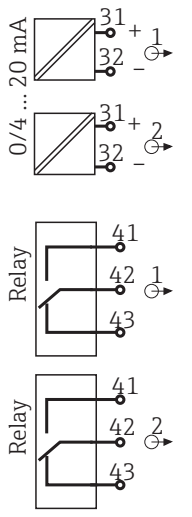
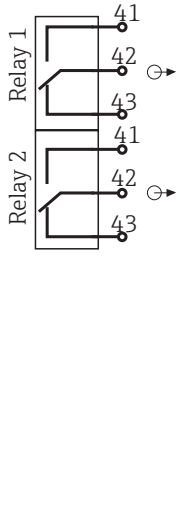
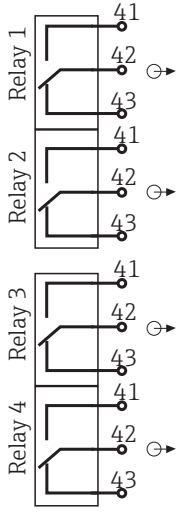
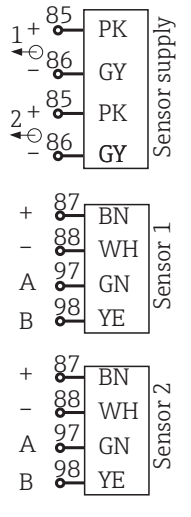
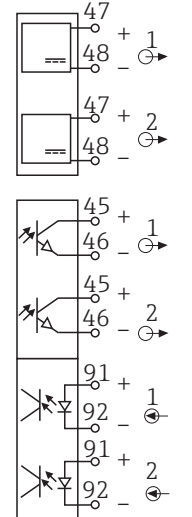
Module name				
AOR	2R	4R	2DS	DIO
				
<ul style="list-style-type: none"> <li>■ 2 x 0/4 to 20 mA analog outputs</li> <li>■ 2 relays</li> <li>■ Order No. 71111053</li> </ul>	<ul style="list-style-type: none"> <li>■ 2 relays</li> <li>■ Order No. 71125375</li> </ul>	<ul style="list-style-type: none"> <li>■ 4 relays</li> <li>■ Order No. 71125376</li> </ul>	<ul style="list-style-type: none"> <li>■ 2 digital sensor inputs</li> <li>■ 2 power supply systems for digital sensors</li> <li>■ Order No. 71135631</li> </ul>	<ul style="list-style-type: none"> <li>■ 2 digital inputs</li> <li>■ 2 digital outputs with auxiliary voltage</li> <li>■ Order No. 71135638</li> </ul>
				

Module name				
2AO	4AO	2AI	485	ETH
<ul style="list-style-type: none"> <li>2 x 0/4 to 20 mA analog outputs</li> <li>Order No. 71135632</li> </ul>	<ul style="list-style-type: none"> <li>4 x 0/4 to 20 mA analog outputs</li> <li>Order No. 71135633</li> </ul>	<ul style="list-style-type: none"> <li>2 x 0/4 to 20mA analog inputs</li> <li>Order No. 71135639</li> </ul>	<ul style="list-style-type: none"> <li>Ethernet (web server or Modbus TCP)</li> <li>5V power supply for PROFIBUS DP termination</li> <li>RS485 (PROFIBUS DP or Modbus RS485)</li> <li>Order No. 71135634</li> </ul>	<ul style="list-style-type: none"> <li>Web server and Ethernet/IP or Modbus TCP</li> <li>Order No. 71272410</li> </ul>



**PROFIBUS DP (module 485)**

Contacts 95, 96 and 99 are bridged in the connector. This ensures that PROFIBUS communication is not interrupted if the connector is disconnected.

Protective ground connection

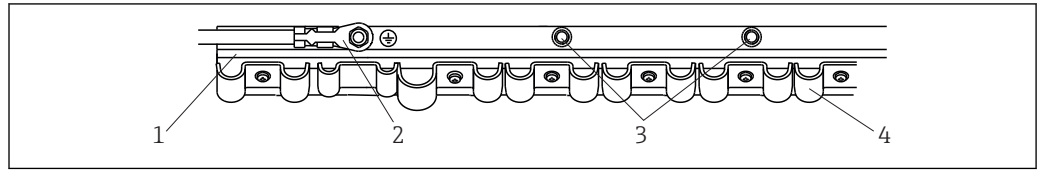

A0025171

16 Cable mounting rail and associated function (field device)

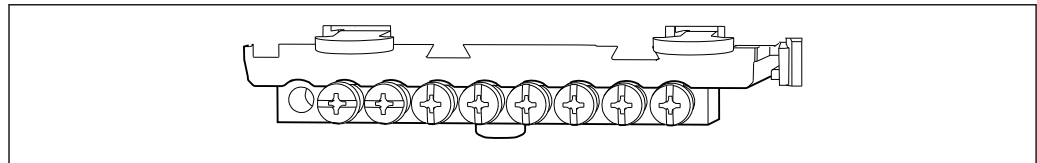

A0025366

17 Mounting rail for functional ground connections (cabinet device)

- |   |   |
|---|---|
| 1 Cable mounting rail   | 3 Additional threaded bolts for ground connections      |
| 2 Threaded bolt (protective ground connection, central grounding point) | 4 Cable clamps (fixing and grounding the sensor cables) |

Sensor connection

Photometer sensors

Sensor types	Sensor cable	Sensors
Analog photometer sensors without additional internal power supply	CUK80	<ul style="list-style-type: none"> <li>■ OUSAF12</li> <li>■ OUSAF21</li> <li>■ OUSAF22</li> <li>■ OUSAF44</li> <li>■ OUSAF46</li> <li>■ OUSTF10</li> <li>■ OUSBT66</li> </ul>
	Fixed cable	OUSAF11

Sensors with Memosens protocol

Sensor types	Sensor cable	Sensors
Digital sensors <b>without</b> additional internal power supply	With plug-in connection and inductive signal transmission	<ul style="list-style-type: none"> <li>■ pH sensors</li> <li>■ ORP sensors</li> <li>■ Combined sensors</li> <li>■ Oxygen sensors (amperometric and optical)</li> <li>■ Conductivity sensors with conductive measurement of conductivity</li> <li>■ Chlorine sensors (disinfection)</li> </ul>
	Fixed cable	Conductivity sensors with inductive measurement of conductivity
Digital sensors with additional internal power supply	Fixed cable	<ul style="list-style-type: none"> <li>■ Turbidity sensors</li> <li>■ Sensors for interface measurement</li> <li>■ Sensors for measuring the spectral absorption coefficient (SAC)</li> <li>■ Nitrate sensors</li> <li>■ Optical oxygen sensors</li> <li>■ Ion-sensitive sensors</li> </ul>

The following rule applies if connecting CUS71D sensors:

- The maximum number of Memosens inputs is limited to two.
- Any combination of CUS71D or other sensors is possible.

Types of connection

- Direct connection of sensor cable to terminal connector of the sensor module PEM and of Memosens module 2DS or of base module E (→ 18 ff.)(Memosens sensors only)
- Optional for Memosens sensors: Sensor cable plug connected to the M12 sensor socket on the underside of the device (field device)  
With this type of connection, the device is already wired at the factory (→ 22).

Sensor cable connected directly

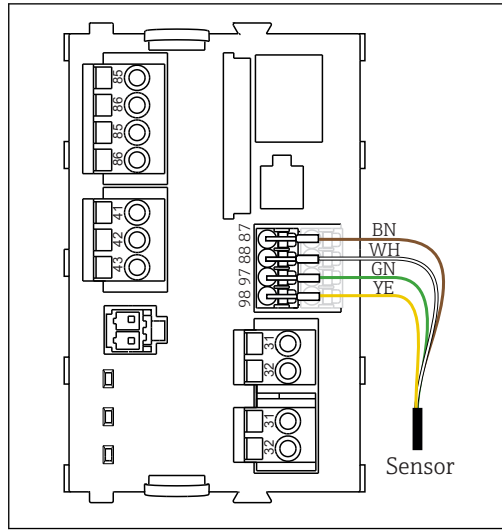

A0023038

18 Memosens sensors without additional supply voltage

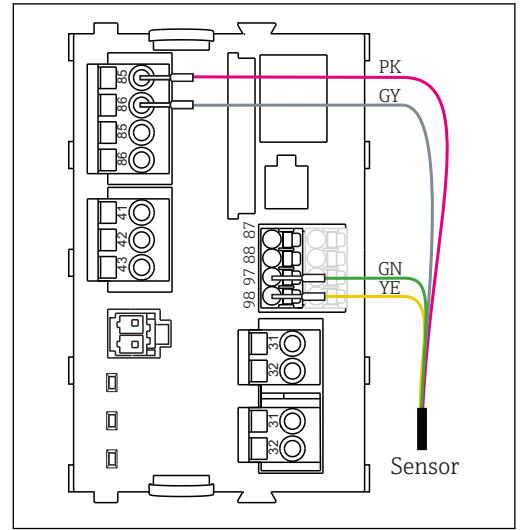

A0023039

19 Memosens sensors with additional supply voltage

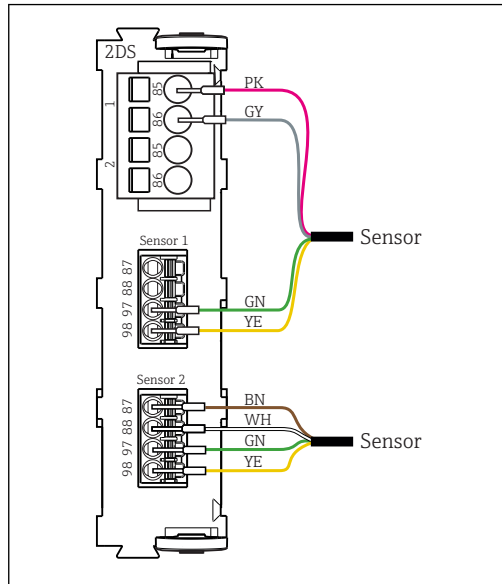

A0033206

20 Memosens sensors with and without additional supply voltage at sensor module 2DS

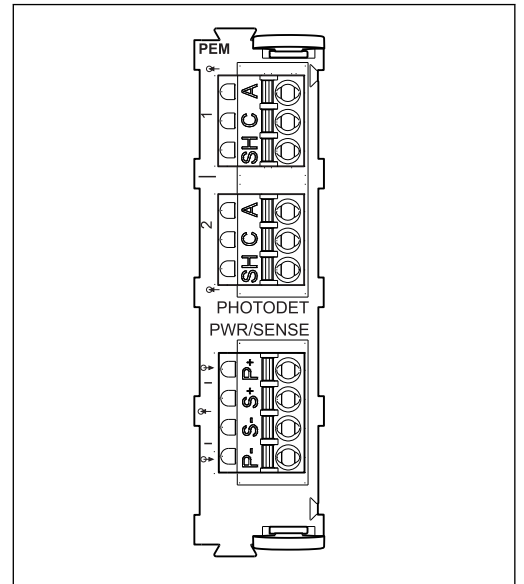

A0028599

21 PEM module

Connecting photometer sensors to PEM module

Sensor	Cable color	PEM terminal	Assignment
OUSAF11	YE (thick)	P+	Lamp voltage +
OUSAF12	YE (thin)	S+	Recording lamp voltage +
	BK (thin)	S-	Recording lamp voltage -
	BK (thick)	P-	Lamp voltage -
	RD	A (1)	Sensor +
	BK <sup>1)</sup> / WH <sup>2)</sup>	C(1)	Sensor -
	GY	SH (1)	Shield

Sensor	Cable color	PEM terminal	Assignment
OUSAF21	YE (thick)	P+	Lamp voltage +
OUSAF22	YE (thin)	S+	Recording lamp voltage +
OUSTF10	BK (thin)	S-	Recording lamp voltage -
OUSAF44	BK (thick)	P-	Lamp voltage -
	RD	A (1)	Measuring detector sensor +
	BK	C(1)	Measuring detector sensor -
	GY	SH (1)	Measuring detector screening
	WH	A (2)	Sensor reference +
	GN	C(2)	Sensor reference -
	GY	SH (2)	Reference screening
OUSAF46	PEM module 1		
 2 PEM modules necessary	YE (thick)	P+	Lamp voltage +
	YE (thin)	S+	Recording lamp voltage +
	BK (thin)	S-	Recording lamp voltage -
	BK (thick)	P-	Lamp voltage -
	RD	A (1)	Measuring detector sensor +
	BK	C(1)	Measuring detector sensor -
	GY	SH (1)	Measuring detector screening
	WH (lamp)	A (2)	Sensor reference +
	GN (lamp)	C(2)	Sensor reference -
	GY (lamp)	SH (2)	Reference screening
	PEM module 2		
	WH	A (1)	Measuring detector sensor +
	GN	C(1)	Measuring detector sensor -
	GY	SH (1)	Measuring detector screening
	RD (lamp)	A (2)	Sensor reference +
	BK (lamp)	C(2)	Sensor reference -
	GY (lamp)	SH (2)	Reference screening
OUSBT66	BN	P+	Lamp voltage +
	BN	S+	Recording lamp voltage +
	BK	P-	Lamp voltage -
	BK	S-	Recording lamp voltage -
	RD	A (1)	Sensor +
	OG	C(1)	Sensor -
	TP	SH (1)	Shield

1) OUSAF12

2) OUSAF11

**Memosens connection via M12 plug-in connection (field device only)**

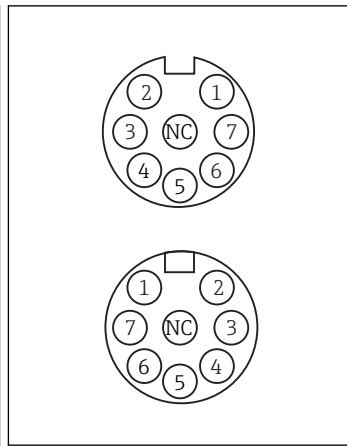
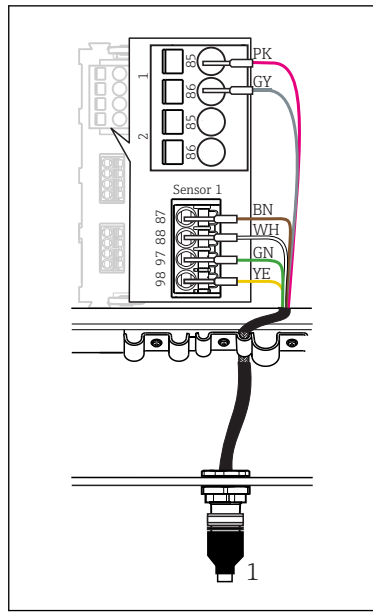

Device versions with a pre-installed M12 socket are ready-wired upon delivery.

Please note the following:

- The internal device wiring is always the same regardless of what kind of sensor you connect to the M12 socket (plug&play).
- The signal or power supply cables are assigned in the sensor head in such a way that the PK and GY power supply cables are either used (e.g. optical sensors) or not (e.g. pH or ORP sensors).

22 M12 plug-in connection (e.g. at sensor module)

1 Sensor cable with M12 connector

23 M12 assignment Top: socket Bottom: connector (top view in each case)

- 1 PK (24 V)
- 2 GY (Ground 24 V)
- 3 BN (3 V)
- 4 WH (Ground 3 V)
- 5 GN (Memosens)
- 6 YE (Memosens)
- 7, Not connected
- NC

## Performance characteristics

**Response time**

**Current outputs**

$t_{90}$  = max. 500 ms for an increase from 0 to 20 mA

**Current inputs**

$t_{90}$  = max. 330 ms for an increase from 0 to 20 mA

**Digital inputs and outputs**

$t_{90}$  = max. 330 ms for an increase from low to high

**Reference temperature**

25 °C (77 °F)

**Measured error for sensor inputs**

**Photometer**

- 0 to 2.5 AU / to 50 OD  
0.3 % of measuring range at 25 °C (77 °F)  
Max. 1 % of measuring range
- 0 to 200 FTU / 0 to 200 ppm DE  
Max. 2 % of measuring range



The photometer lamps will not operate at full capacity until a warm-up period of 30 minutes has elapsed. Only then do the specified inaccuracies apply.

**Memosens sensors**

→ Documentation of the connected sensor

**Measured error for current inputs and outputs**

**Typical measured errors:**

- < 20  $\mu$ A (with current values < 4 mA)
- < 50  $\mu$ A (with current values 4 to 20 mA)
- at 25 °C (77 °F) each

**Additional measured error depending on the temperature:**

< 1.5  $\mu$ A/K

Frequency tolerance of digital inputs and outputs	≤ 1%
Resolution of current inputs and outputs	< 5 μA
Repeatability	→ Documentation of the connected sensor

## Installation

### Installation conditions **Mounting plate (field device)**

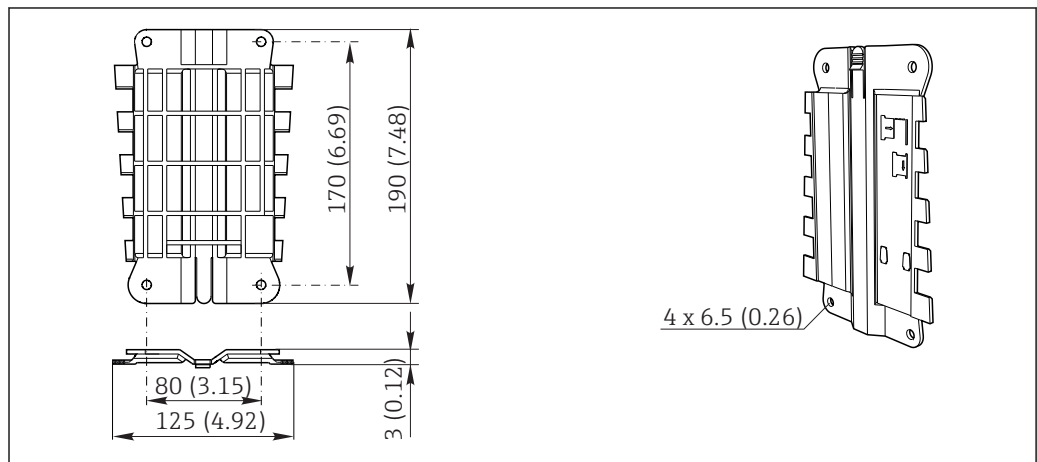

A0012426

24 Mounting plate, dimensions in mm (in)

### Weather protection cover (field device)

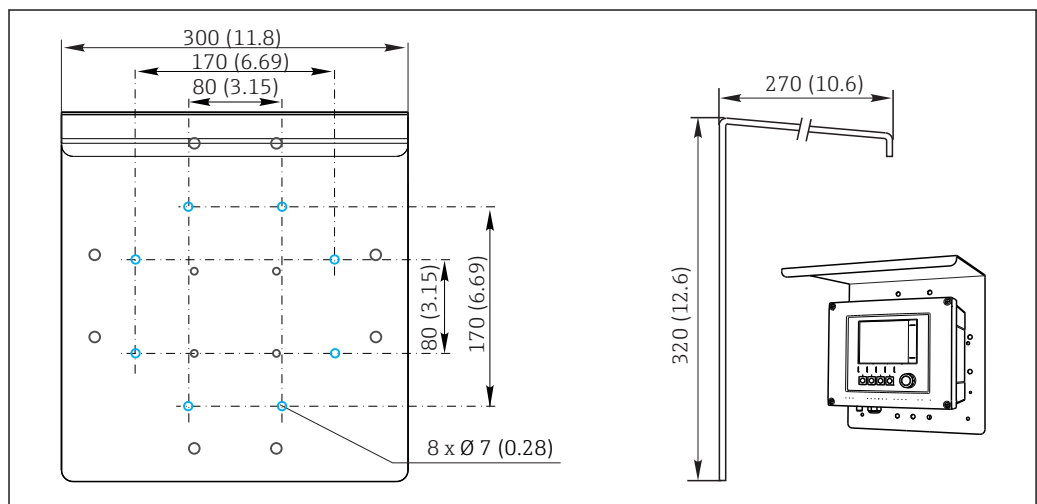

A0012428

25 Dimensions in mm (in)



Installation

Post mounting

**i** You require the post mounting kit (optional) to mount the unit on a pipe, post or railing (square or circular, clamping range 20 to 61 mm (0.79 to 2.40")).

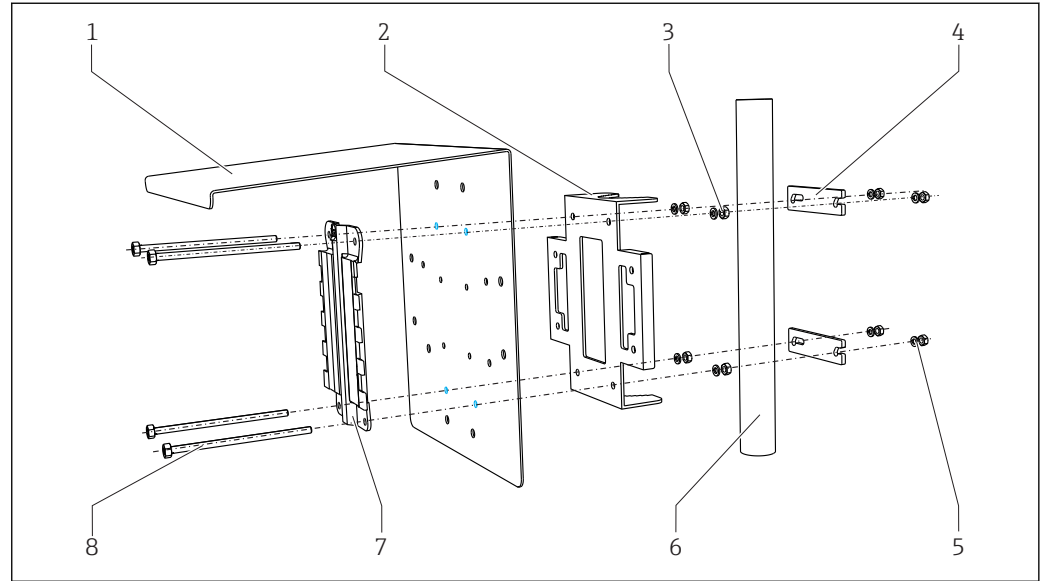

A0033044

**26** Post mounting

- |   |   |   |   |
|---|---|---|---|
| 1 | Weather protection cover (optional)         | 5 | Spring washers and nuts (post mounting kit) |
| 2 | Post mounting plate (post mounting kit)     | 6 | Pipe or railing (circular/square)           |
| 3 | Spring washers and nuts (post mounting kit) | 7 | Mounting plate                              |
| 4 | Pipe clamps (post mounting kit)             | 8 | Threaded rods (post mounting kit)           |

Rail mounting

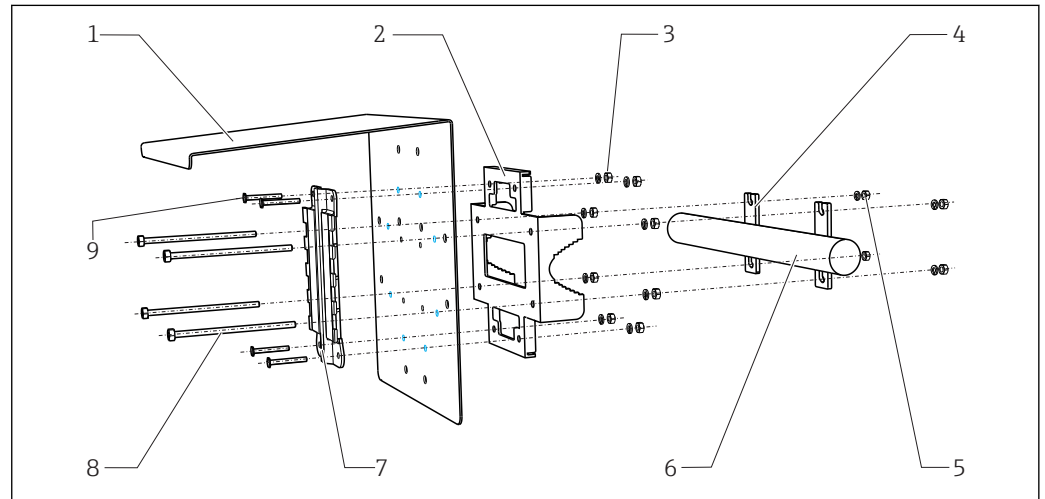

A0012668

**27** Rail mounting

- |   |   |   |                                   |
|---|---|---|-----------------------------------|
| 1 | Weather protection cover (optional)         | 6 | Pipe or railing (circular/square) |
| 2 | Post mounting plate (post mounting kit)     | 7 | Mounting plate                    |
| 3 | Spring washers and nuts (post mounting kit) | 8 | Threaded rods (post mounting kit) |
| 4 | Pipe clamps (post mounting kit)             | 9 | Screws (post mounting kit)        |
| 5 | Spring washers and nuts (post mounting kit) |   |                                   |

### Wall mounting

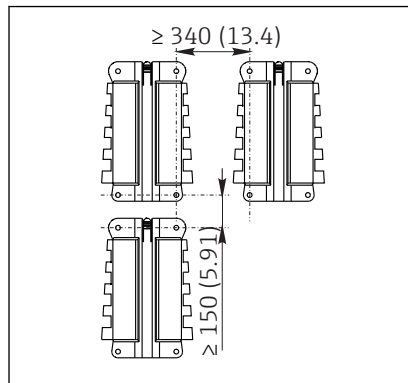

▣ 28 Installation clearance in mm (in)

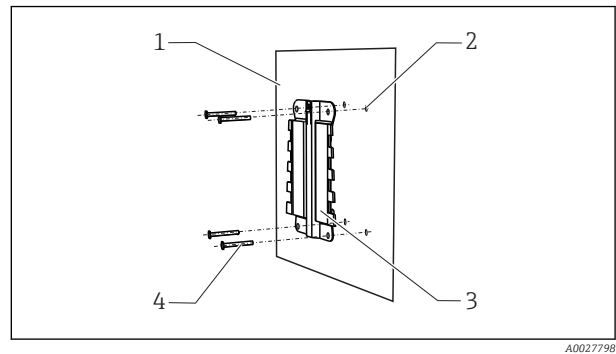

▣ 29 Wall mounting

- 1 Wall
- 2 4 drill holes <sup>1)</sup>
- 3 Mounting plate
- 4 Screws Ø 6 mm (not part of scope of supply)

<sup>1)</sup>The size of the drill holes depends on the wall plugs used. The wall plugs and screws must be provided by the customer.

### Mounting on DIN rail as per IEC 60715

#### NOTICE

#### Incorrect mounting location in the cabinet, spacing regulations not observed

Possible malfunctions as a result of heat buildup and interference from neighboring devices!

- ▶ Do not position the device directly above sources of heat. The temperature specification must be observed.
- ▶ The components are designed for convection-based cooling. Avoid heat buildup. Ensure openings are not covered, e. g. by cables.
- ▶ Observe the specified distances to other devices.
- ▶ Physically separate the device from frequency converters and high-voltage devices.
- ▶ Recommended installation direction: horizontal. The specified ambient conditions, and particularly the ambient temperatures, only apply for horizontal installation.
- ▶ Vertical orientation is also possible. However, this requires additional fixing clips at the place of installation to hold the device in position on the DIN rail.
- ▶ Recommended installation of power unit: to the left of the device.

**The following minimum clearance specifications must be observed:**

- Distances at the side in relation to other devices incl. power units and to the wall of the cabinet:  
at least 20 mm (0.79 inch)
- Distance above and below the device and depth distance (to control cabinet door or other devices installed there):  
at least 50 mm (1.97 inch)

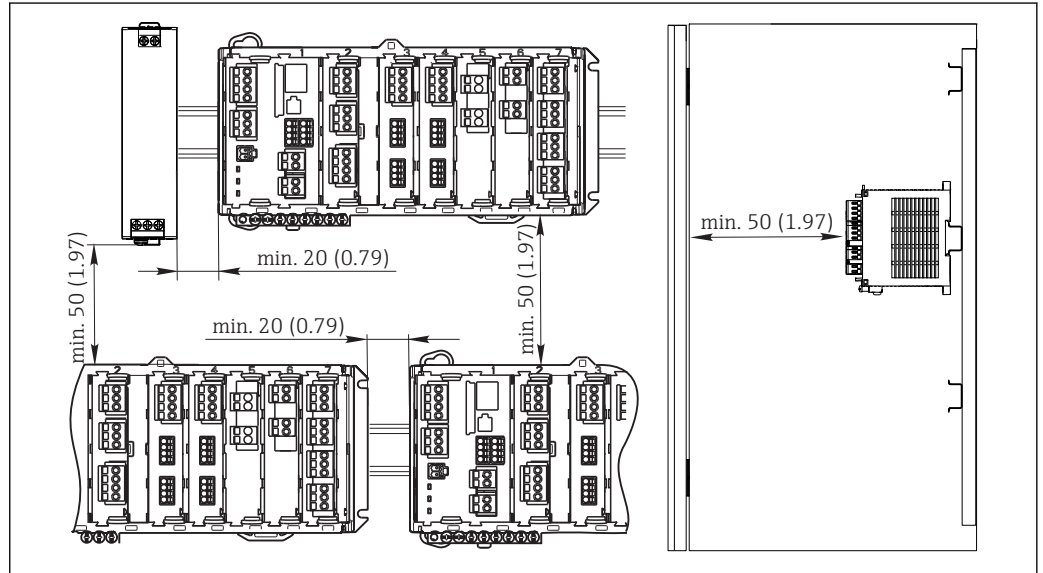

A0027858

30 Minimum clearance in mm (in)

**Wall mounting**

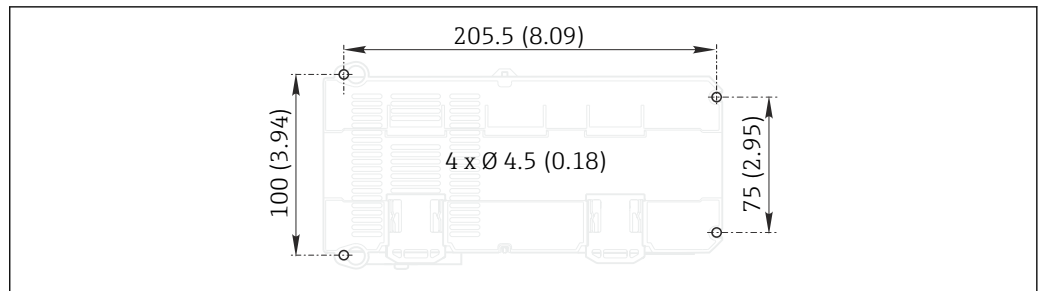

A0027859

31 Drilling pattern for wall mounting in mm (in)

**Mounting the external display**

The mounting plate also serves as the drilling template. The marks on the side help you mark the position of the drill holes.

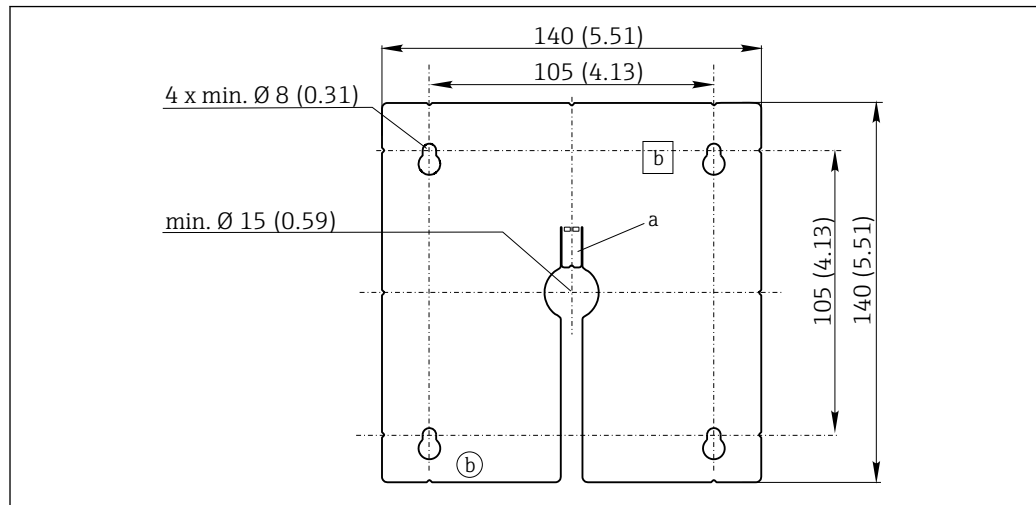

A0025371

32 Mounting plate of external display, dimensions in mm (in)

a Retaining tab

b Production-related recesses, no function for the user

## Environment

### Ambient temperature range

#### Cabinet device

0 to 50 °C (32 to 120 °F)

#### External display (optional)

-20 to 60 °C (0 to 140 °F)

#### Field device

-20 to 50 °C (0 to 120 °F)

### Storage temperature

#### Cabinet device

-25 to 85 °C (-13 to 185 °F)

#### Field device

-40 to +80 °C (-40 to 175 °F)

### Humidity

#### Cabinet device

5 to 85%, not condensing

#### External display (in installed state)

5 to 95%, not condensing

#### Field device

10 to 95 %, non-condensating

### Degree of protection

#### Cabinet device

IP20 shock protection

#### External display

IP66 front-panel, when installed correctly including seal for housing door

#### Field device

IP 66/67, impermeability and corrosion resistance in accordance with NEMA TYPE 4X

<b>Climate class (cabinet device only)</b>	As per IEC 60654-1: B2																								
<b>Vibration resistance</b>	<p><b>Environmental tests</b>            Vibration test based on DIN EN 60068-2, October 2008            Vibration test based on DIN EN 60654-3, August 1998</p> <p><b>Post or pipe mounting</b></p> <table border="0"> <tr> <td>Frequency range</td> <td colspan="2">10 to 500 Hz (sinusoidal)</td> </tr> <tr> <td>Amplitude</td> <td>10 to 57.5 Hz:</td> <td>0.15 mm</td> </tr> <tr> <td></td> <td>57.5 to 500 Hz:</td> <td>2 g <sup>1)</sup></td> </tr> <tr> <td>Test duration</td> <td colspan="2">10 frequency cycles/ spatial axis, in 3 spatial axes (1 oct./min)</td> </tr> </table> <p><b>Wall mounting</b></p> <table border="0"> <tr> <td>Frequency range</td> <td colspan="2">10 to 150 Hz (sinusoidal)</td> </tr> <tr> <td>Amplitude</td> <td>10 to 12.9 Hz:</td> <td>0.75 mm</td> </tr> <tr> <td></td> <td>12.9 to 150 Hz:</td> <td>0.5 g <sup>1)</sup></td> </tr> <tr> <td>Test duration</td> <td colspan="2">10 frequency cycles/ spatial axis, in 3 spatial axes (1 oct./min)</td> </tr> </table> <p>1) g ... gravitational acceleration (1 g ≈ 9.81 m/s<sup>2</sup>)</p>	Frequency range	10 to 500 Hz (sinusoidal)		Amplitude	10 to 57.5 Hz:	0.15 mm		57.5 to 500 Hz:	2 g <sup>1)</sup>	Test duration	10 frequency cycles/ spatial axis, in 3 spatial axes (1 oct./min)		Frequency range	10 to 150 Hz (sinusoidal)		Amplitude	10 to 12.9 Hz:	0.75 mm		12.9 to 150 Hz:	0.5 g <sup>1)</sup>	Test duration	10 frequency cycles/ spatial axis, in 3 spatial axes (1 oct./min)	
Frequency range	10 to 500 Hz (sinusoidal)																								
Amplitude	10 to 57.5 Hz:	0.15 mm																							
	57.5 to 500 Hz:	2 g <sup>1)</sup>																							
Test duration	10 frequency cycles/ spatial axis, in 3 spatial axes (1 oct./min)																								
Frequency range	10 to 150 Hz (sinusoidal)																								
Amplitude	10 to 12.9 Hz:	0.75 mm																							
	12.9 to 150 Hz:	0.5 g <sup>1)</sup>																							
Test duration	10 frequency cycles/ spatial axis, in 3 spatial axes (1 oct./min)																								
<b>Electromagnetic compatibility</b>	Interference emission and interference immunity as per EN 61326-1:2013, Class A for Industry																								
<b>Electrical safety</b>	<p><b>Cabinet device</b></p> <p>IEC 61010-1, Class I equipment            Low voltage: overvoltage category II            Environment &lt; 2000 m (&lt; 6562 ft) above MSL</p> <p><b>Field device</b></p> <p>IEC 61010-1, Class I equipment            Low voltage: overvoltage category II            Environment &lt; 3000 m (&lt; 9840 ft) above MSL</p>																								
<b>Degree of contamination</b>	<p><b>Cabinet device</b></p> <p>The product is suitable for pollution degree 2.</p> <p><b>Optional display (for cabinet device)</b></p> <p>The product is suitable for pollution degree 4.</p> <p><b>Field device</b></p> <p>The product is suitable for pollution degree 4.</p>																								
<b>Pressure compensation to environment (field device only)</b>	<p>Filter made of GORE-TEX used as pressure compensation element            Ensures pressure compensation to environment and guarantees IP protection.</p>																								

## Mechanical construction

### Dimensions

### Field device

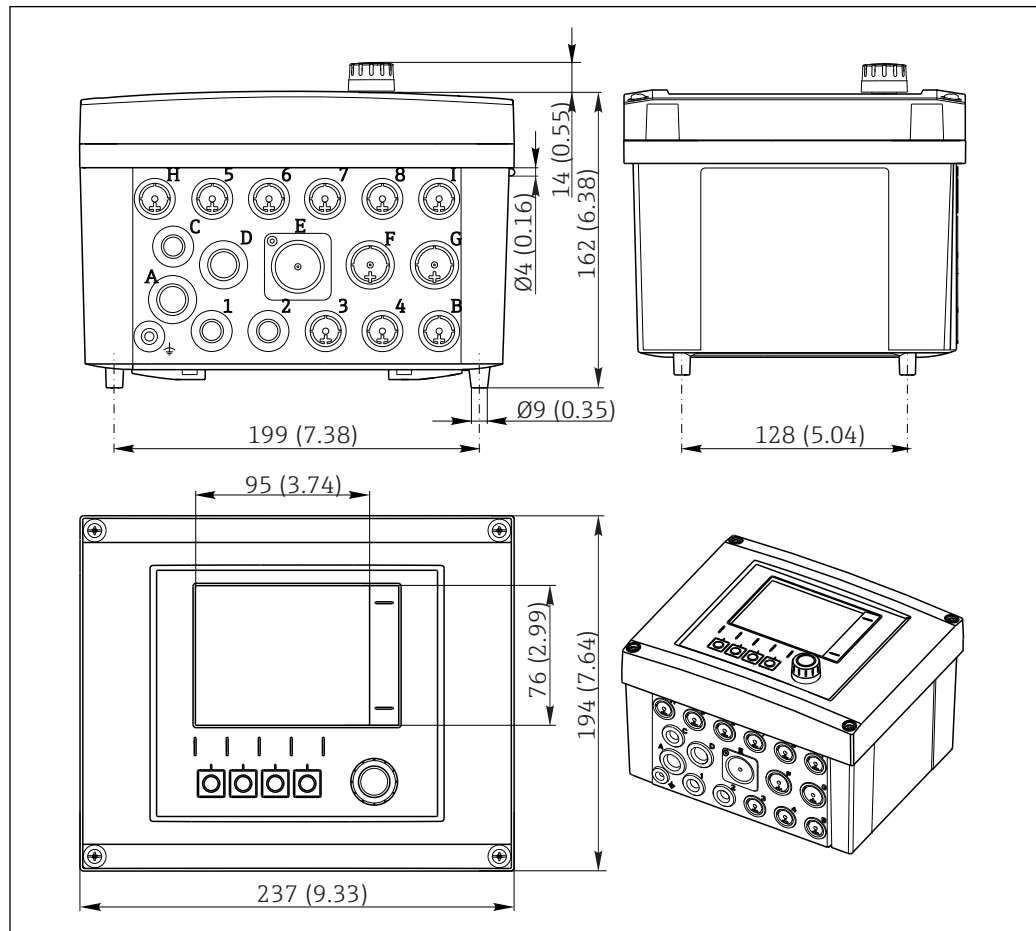

A0012396

33 Dimensions of field housing in mm (inch)

cabinet device

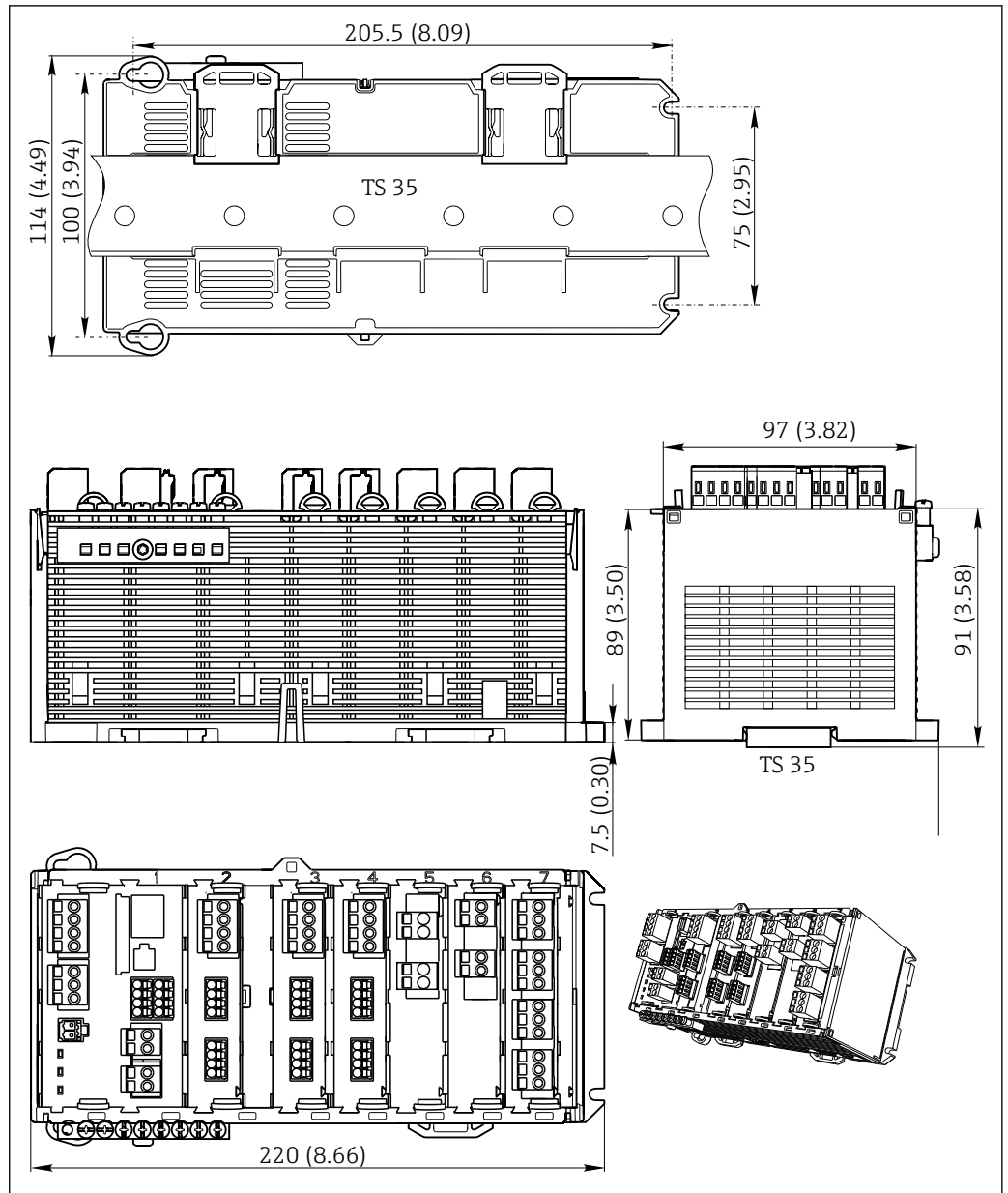

A0025345

34 Dimensions in mm (inch)

**Optional display (for cabinet device)**

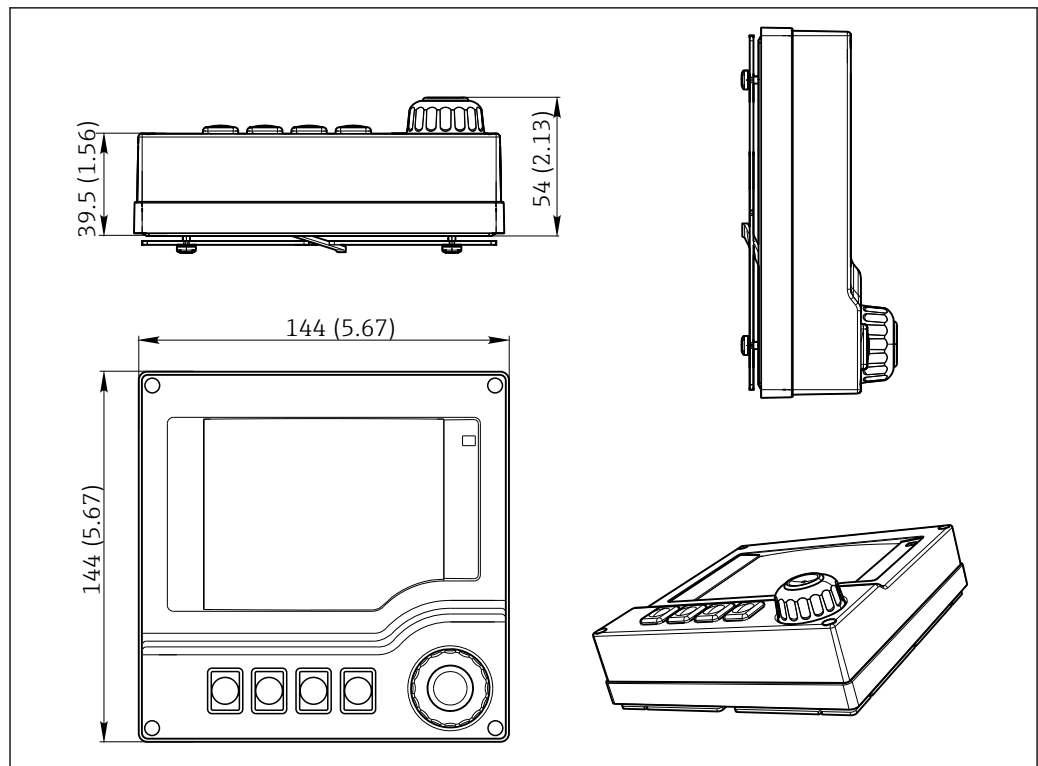

A0025346

35 Dimensions in mm (inch)

**External power units (for cabinet device)**

Depending on the version ordered, a power unit for connection to 230 V or 24 V is supplied. There are two delivery variants for each version (cannot be selected). The factory-preferred variant is shown on the left in each case.

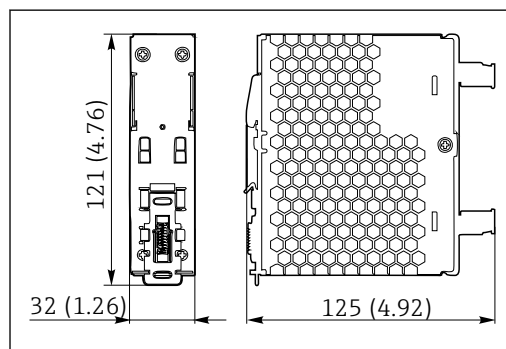

A0025738

36 Power unit 230 V

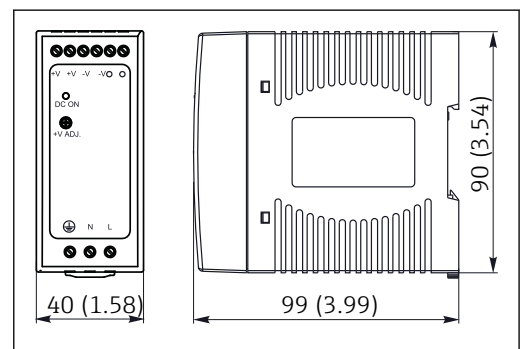

A0025739

37 Power unit 230 V (optional)

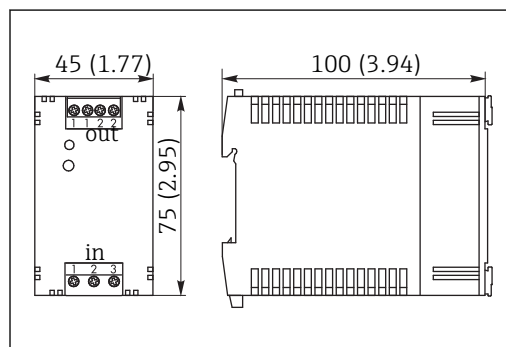

A0025784

38 Power unit 24 V

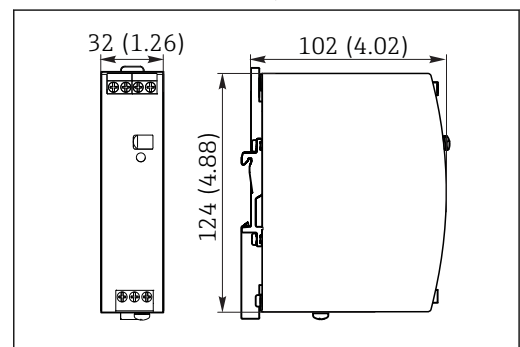

A0025786

39 Power unit 24 V (optional)



**Service display (accessories)**

The service display comprises:

- Portable display (same dimensions as under "Optional display")
- Cover to protect the display and to hook it onto the (open) cabinet door

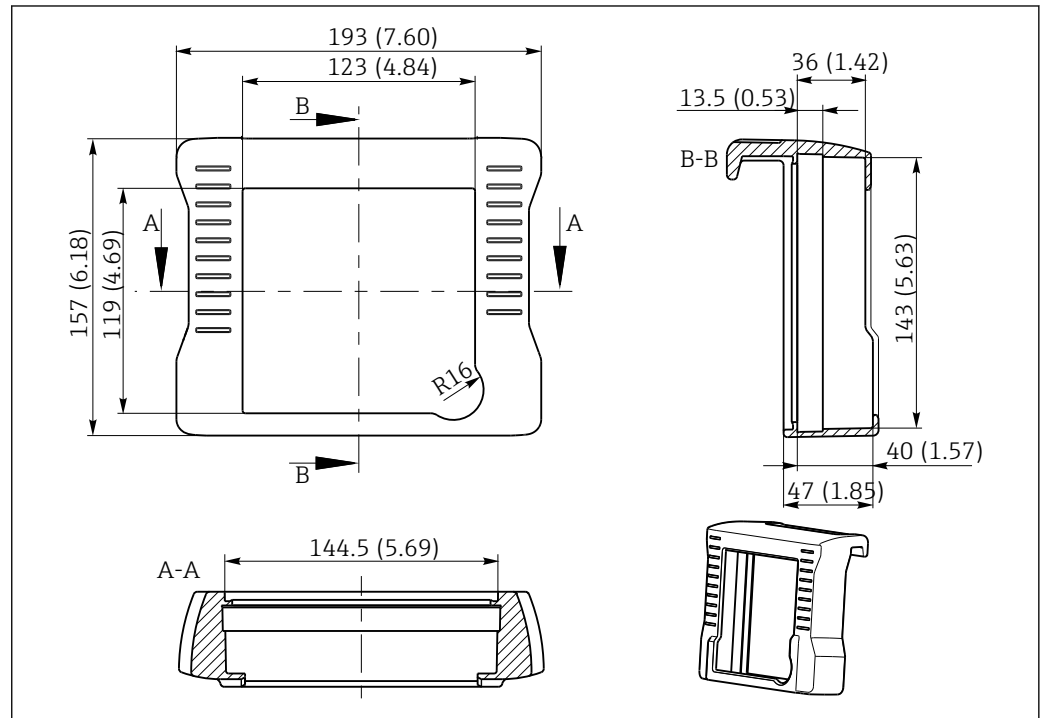

40 Dimensions of the service display cover in mm (inch)

A0025343

**Weight**

**Field device**

Complete device	Approx. 2.1 kg (4.63 lbs), depending on the version
Individual module	Approx. 0.06 kg (0.13 lbs)
SD card	Max. 5 g (0.17 oz)

**Cabinet device**

CM44P (fully configured)	Approx. 0.95 kg (2.1 lbs)
Individual module	Approx. 0.06 kg (0.13 lbs)
External display (excluding cables)	Approx. 0.56 kg (1.2 lbs)
Service display cover	0.46 kg (1 lbs)
External power unit	0.27 to 0.42 kg (0.60 to 0.92 lbs), depending on the power unit variant
SD card	Max. 5 g (0.17 oz)

**Materials**

Housing base and DIN rail housing	PC-FR
Display cover	PC-FR
Display foil and soft keys (field device)	PE
Housing seal Display seal	EPDM
Soft keys (optional display)	EPDM
Module side panels	PC-FR
Module covers	PBT GF30 FR
Cable mounting rail (field device) Terminal strip (cabinet device)	PBT GF30 FR, stainless steel 1.4301 (AISI304) Nickel-plated brass
Clamps Ground terminals	Stainless steel 1.4301 (AISI304)
Threaded fasteners	Stainless steel 1.4301 (AISI304)
Mounting plate (optional display)	Stainless steel 1.4301 (AISI304)
Securing screws (optional display)	Steel, galvanized
Cover for service display (accessories)	EPDM
Cable glands	Polyamide V0 as per UL94

## Operability

**display**

Graphic display:

- Resolution: 240 x 160 pixel
- Back light with switch-off function
- Red display background for alarms alerts users to errors
- Transflective display technology for maximum contrast even in bright environments
- User-definable measuring menus mean you can always keep track of the values that are important for your application.

**Operating concept**

The simple and structured operating concept sets new standards:

- Intuitive operation with the navigator and soft keys
- Fast configuration of application-specific measurement options
- Easy configuration and diagnosis thanks to plain-text display
- All languages that can be ordered are available in every device



41 Easy operation

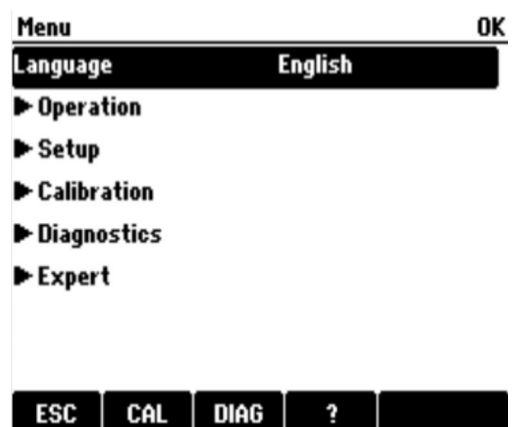

42 Plain-text menu

Local operation

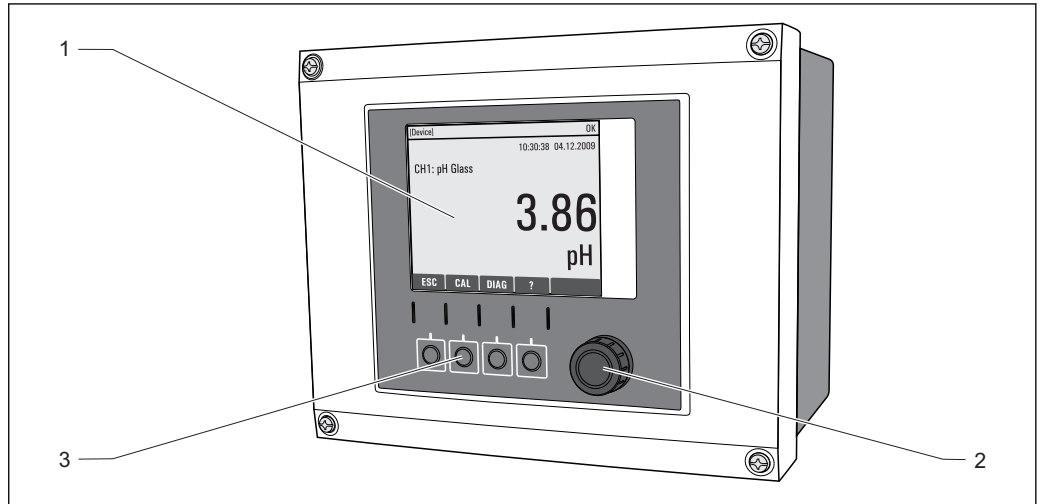

A0011764

43 Overview of operation (using the example of the field device)

- 1 Display (with red display background in alarm condition)
- 2 Navigator (jog/shuttle and press/hold function)
- 3 Soft keys (function depends on menu)

Remote operation

Via HART (e.g. using HART modem and FieldCare)

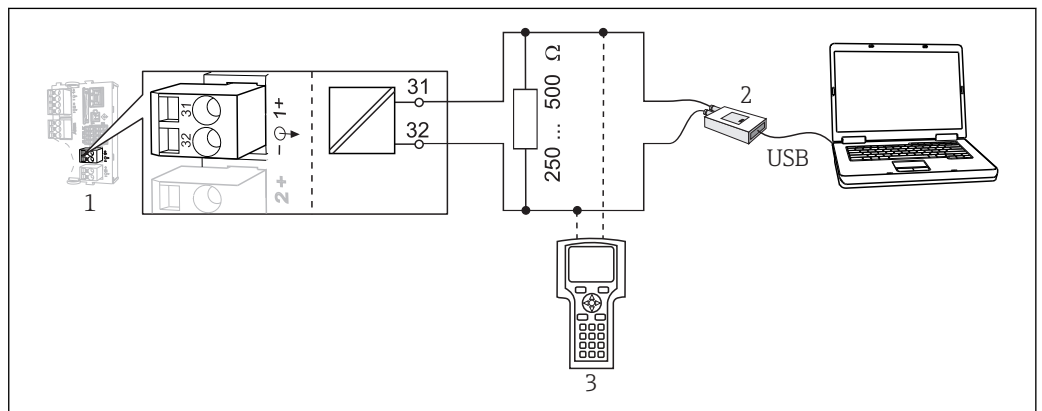

A0028995

44 HART using modem

- 1 Device module Base L, H or E: current output 1 with HART
- 2 HART modem for connection to PC, e.g. Commubox FXA191 (RS232) or FXA195 <sup>1)</sup> (USB)
- 3 HART handheld terminal

<sup>1)</sup> Switch position "on" (substitutes the resistor)

Via PROFIBUS DP

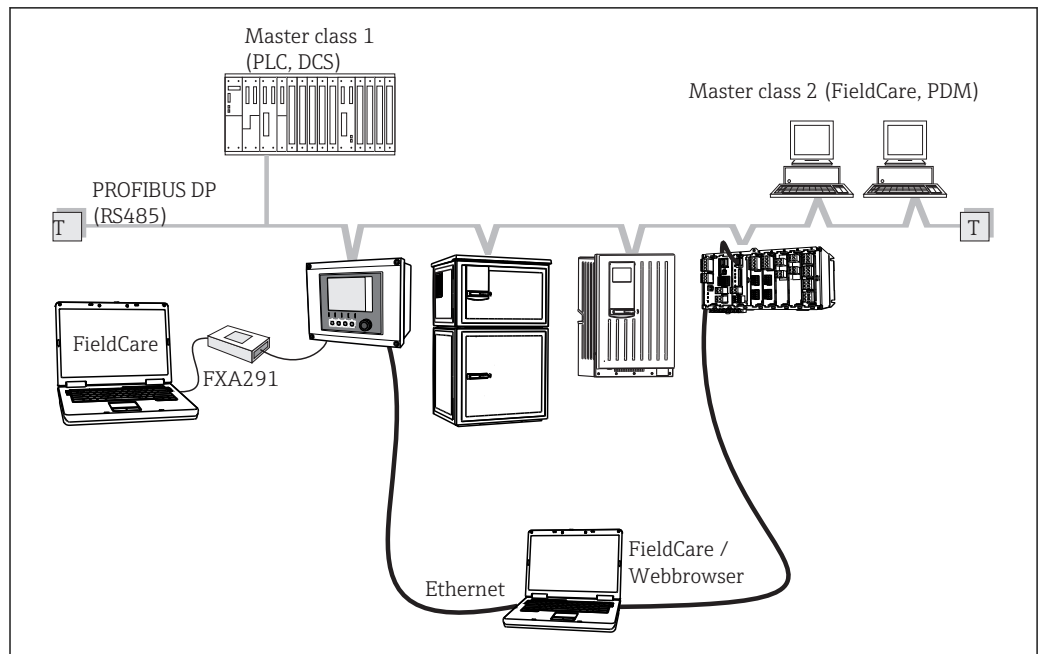

A0028991

45 PROFIBUS DP

T Terminating resistor

Via Modbus RS485

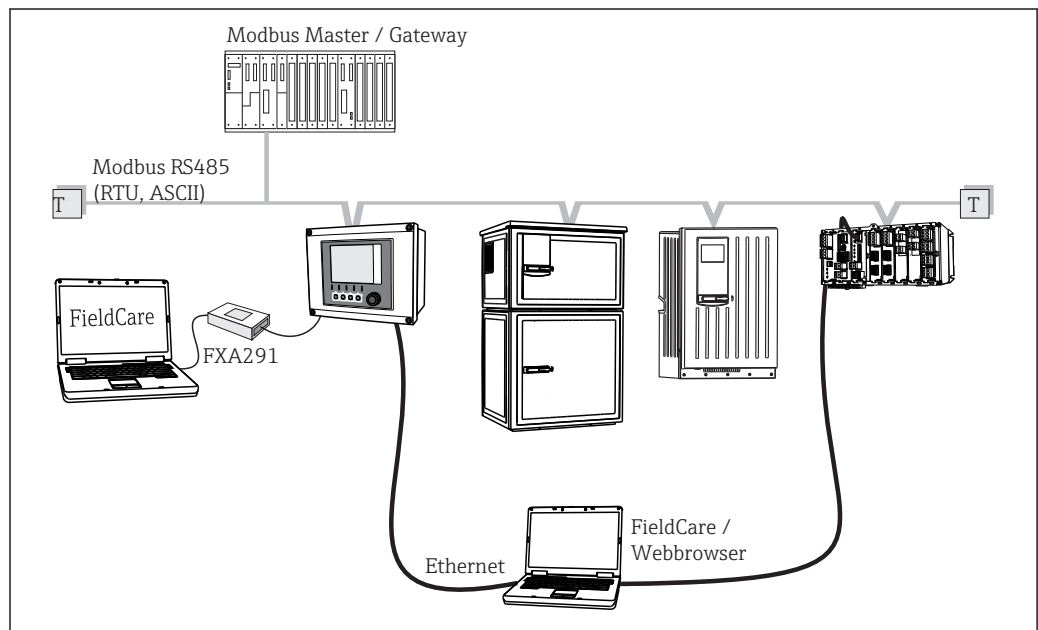

A0028993

46 Modbus RS485

T Terminating resistor

Via Ethernet/Web server/Modbus TCP/EtherNet/IP

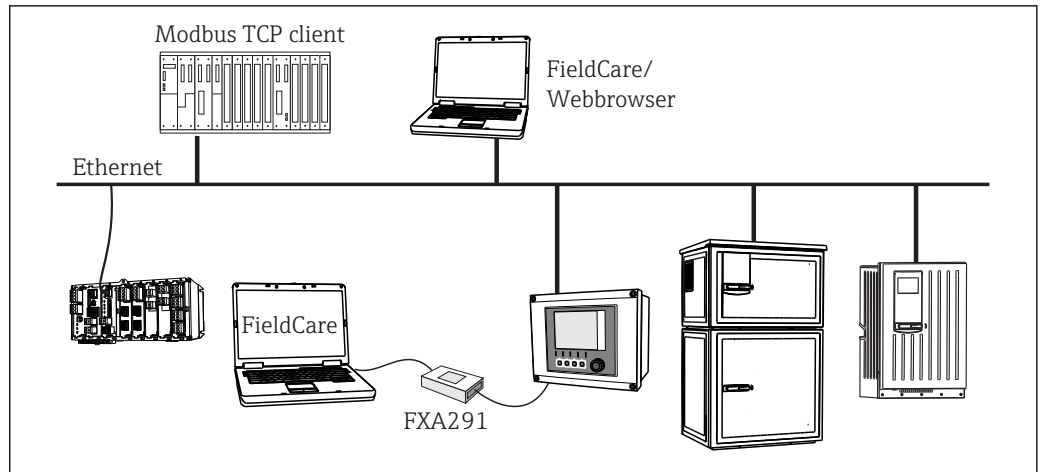

47 Modbus TCP and/or EtherNet/IP

A0028994

Language packages

The language selected in the product structure is the operating language preset at the factory. All other languages can be selected using the menu.

- English (US)
- German
- Chinese (Simplified, PR China)
- Czech
- Dutch
- French
- Italian
- Japanese
- Polish
- Portuguese
- Russian
- Spanish
- Swedish
- Turkish
- Hungarian
- Croatian
- Vietnamese

The availability of other languages can be checked via the product structure at [www.endress.com/cm44p](http://www.endress.com/cm44p).

Certificates and approvals

CE mark

The product meets the requirements of the harmonized European standards. As such, it complies with the legal specifications of the EU directives. The manufacturer confirms successful testing of the product by affixing to it the CE mark.

## Ordering information

### Product page

[www.endress.com/cm44p](http://www.endress.com/cm44p)

### Product Configurator

On the product page there is a **Configure** button to the right of the product image.

1. Click this button.
  - ↳ The Configurator opens in a separate window.
2. Select all the options to configure the device in line with your requirements.
  - ↳ In this way, you receive a valid and complete order code for the device.
3. Export the order code as a PDF or Excel file. To do so, click the appropriate button on the right above the selection window.

 For many products you also have the option of downloading CAD or 2D drawings of the selected product version. Click the **CAD** tab for this and select the desired file type using picklists.

### Scope of delivery

The scope of delivery comprises:

- 1 multichannel controller in the version ordered
- 1 mounting plate
- 1 wiring label (attached at the factory to the inside of the display cover)
- 1 external display (if selected as an option)<sup>2)</sup>
- 1 DIN rail power unit incl. Cable (cabinet device only)
- 1 printed copy of the Operating Instructions for DIN rail power unit (cabinet device only)
- 1 printed copy of the Brief Operating Instructions in the language ordered

## Accessories

The following are the most important accessories available at the time this documentation was issued.

- ▶ For accessories not listed here, please contact your Service or Sales Center.

### Measuring cable

#### CUK80 cable set

- Pre-terminated and labeled cables for connecting analog photometer sensors
- Product Configurator on the product page: [www.endress.com/cuk80](http://www.endress.com/cuk80)

#### Memosens data cable CYK10

- For digital sensors with Memosens technology
- Product Configurator on the product page: [www.endress.com/cyk10](http://www.endress.com/cyk10)



Technical Information TI00118C

#### Memosens data cable CYK11

- Extension cable for digital sensors with Memosens protocol
- Product Configurator on the product page: [www.endress.com/cyk11](http://www.endress.com/cyk11)



Technical Information TI00118C

### Sensors

#### Photometer sensors

##### OUSAF11

- Optical sensor for VIS/NIR absorption
- Stainless steel housing and sensor head made from dirt-repellent FEP
- Product Configurator on the product page: [www.endress.com/ousaf11](http://www.endress.com/ousaf11)



Technical Information TI00474C

2) The external display can be selected as an option in the order structure or ordered as an accessory at a later stage.

#### **OUSAF12**

- Optical sensor for the measurement of absorbance
- Variety of materials and process connections available
- Product Configurator on the product page: [www.endress.com/ousaf12](http://www.endress.com/ousaf12)



Technical Information TI00497C

#### **OUSAF22**

- Optical sensor for measuring color concentrations
- Variety of materials and process connections available
- Product Configurator on the product page: [www.endress.com/ousaf22](http://www.endress.com/ousaf22)



Technical Information TI00472C

#### **OUSAF44**

- Optical sensor for measuring UV absorption
- Variety of materials and process connections available
- Hygienic design
- Product Configurator on the product page: [www.endress.com/ousaf44](http://www.endress.com/ousaf44)



Technical Information TI00416C

#### **OUSTF10**

- Optical sensor for measuring turbidity and undissolved solids
- Variety of materials and process connections available
- Product Configurator on the product page: [www.endress.com/oustf10](http://www.endress.com/oustf10)



Technical Information TI00500C

#### **OUSBT66**

- NIR absorption sensor for measuring cell growth and biomass
- Sensor version suitable for pharmaceutical industry
- Product Configurator on the product page: [www.endress.com/ousbt66](http://www.endress.com/ousbt66)



Technical Information TI00469C

#### **Glass electrodes**

##### **Orbisint CPS11D**

- pH sensor for process technology
- Optional SIL version for connecting to SIL transmitter
- With dirt-repellent PTFE diaphragm
- Product Configurator on the product page: [www.endress.com/cps11d](http://www.endress.com/cps11d)



Technical Information TI00028C

##### **Memosens CPS31D**

- pH electrode with gel-filled reference system with ceramic diaphragm
- Product Configurator on the product page: [www.endress.com/cps31d](http://www.endress.com/cps31d)



Technical Information TI00030C

##### **Ceraliquid CPS41D**

- pH electrode with ceramic junction and KCl liquid electrolyte
- Product Configurator on the product page: [www.endress.com/cps41d](http://www.endress.com/cps41d)



Technical Information TI00079C

##### **Ceragel CPS71D**

- pH electrode with reference system including ion trap
- Product Configurator on the product page: [www.endress.com/cps71d](http://www.endress.com/cps71d)



Technical Information TI00245C

##### **Memosens CPS171D**

- pH electrode for bio-fermenters with digital Memosens technology
- Product Configurator on the product page: [www.endress.com/cps171d](http://www.endress.com/cps171d)



Technical Information TI01254C

**Orbipore CPS91D**

- pH electrode with open aperture for media with high dirt load
- Product Configurator on the product page: [www.endress.com/cps91d](http://www.endress.com/cps91d)



Technical Information TI00375C

**Orbipac CPF81D**

- Compact pH sensor for installation or immersion operation
- In industrial water and wastewater
- Product Configurator on the product page: [www.endress.com/cpf81d](http://www.endress.com/cpf81d)



Technical Information TI00191C

**Enamel pH electrodes****Ceramax CPS341D**

- pH electrode with pH-sensitive enamel
- Meets highest demands of measuring accuracy, pressure, temperature, sterility and durability
- Product Configurator on the product page: [www.endress.com/cps341d](http://www.endress.com/cps341d)



Technical Information TI00468C

**ORP sensors****Orbisint CPS12D**

- ORP sensor for process technology
- Product Configurator on the product page: [www.endress.com/cps12d](http://www.endress.com/cps12d)



Technical Information TI00367C

**Ceraliquid CPS42D**

- ORP electrode with ceramic junction and KCl liquid electrolyte
- Product Configurator on the product page: [www.endress.com/cps42d](http://www.endress.com/cps42d)



Technical Information TI00373C

**Ceragel CPS72D**

- ORP electrode with reference system including ion trap
- Product Configurator on the product page: [www.endress.com/cps72d](http://www.endress.com/cps72d)



Technical Information TI00374C

**Orbipac CPF82D**

- Compact ORP sensor for installation or immersion operation in process water and wastewater
- Product Configurator on the product page: [www.endress.com/cpf82d](http://www.endress.com/cpf82d)



Technical Information TI00191C

**Orbipore CPS92D**

- ORP electrode with open aperture for media with high dirt load
- Product Configurator on the product page: [www.endress.com/cps92d](http://www.endress.com/cps92d)



Technical Information TI00435C

**pH ISFET sensors****Tophit CPS441D**

- Sterilizable ISFET sensor for low-conductivity media
- Liquid KCl electrolyte
- Product Configurator on the product page: [www.endress.com/cps441d](http://www.endress.com/cps441d)



Technical Information TI00352C

**Tophit CPS471D**

- Sterilizable and autoclavable ISFET sensor for food and pharmaceuticals, process engineering
- Water treatment and biotechnology
- Product Configurator on the product page: [www.endress.com/cps471d](http://www.endress.com/cps471d)



Technical Information TI00283C



#### **Tophit CPS491D**

- ISFET sensor with open aperture for media with high dirt load
- Product Configurator on the product page: [www.endress.com/cps491d](http://www.endress.com/cps491d)



Technical Information TI00377C

#### **pH and ORP combined sensors**

##### **Memosens CPS16D**

- Combined pH/ORP sensor for process technology
- With dirt-repellent PTFE diaphragm
- With Memosens technology
- Product Configurator on the product page: [www.endress.com/cps16D](http://www.endress.com/cps16D)



Technical Information TI00503C

##### **Memosens CPS76D**

- Combined pH/ORP sensor for process technology
- Hygienic and sterile applications
- With Memosens technology
- Product Configurator on the product page: [www.endress.com/cps76d](http://www.endress.com/cps76d)



Technical Information TI00506C

##### **Memosens CPS96D**

- Combined pH/ORP sensor for chemical processes
- With poison-resistant reference with ion trap
- With Memosens technology
- Product Configurator on the product page: [www.endress.com/cps96d](http://www.endress.com/cps96d)



Technical Information TI00507C

#### **Conductivity sensors with inductive measurement of conductivity**

##### **Indumax CLS50D**

- High-durability inductive conductivity sensor
- For standard and hazardous area applications
- With Memosens technology
- Product Configurator on the product page: [www.endress.com/cls50d](http://www.endress.com/cls50d)



Technical Information TI00182C

##### **Indumax H CLS54D**

- Inductive conductivity sensor
- With certified, hygienic design for foodstuffs, beverages, pharmaceuticals and biotechnology
- Product Configurator on the product page: [www.endress.com/cls54d](http://www.endress.com/cls54d)



Technical Information TI00508C

#### **Conductivity sensors with conductive measurement of conductivity**

##### **Condumax CLS15D**

- Conductive conductivity sensor
- For pure water, ultrapure water and hazardous area applications
- Product Configurator on the product page: [www.endress.com/CLS15d](http://www.endress.com/CLS15d)



Technical Information TI00109C

##### **Condumax CLS16D**

- Hygienic, conductive conductivity sensor
- For pure water, ultrapure water and Ex applications
- With EHEDG and 3A approval
- Product Configurator on the product page: [www.endress.com/CLS16d](http://www.endress.com/CLS16d)



Technical Information TI00227C

**Condumax CLS21D**

- Two-electrode sensor in plug-in head version version
- Product Configurator on the product page: [www.endress.com/CLS21d](http://www.endress.com/CLS21d)



Technical Information TI00085C

**Memosens CLS82D**

- Four-electrode sensor
- With Memosens technology
- Product Configurator on the product page: [www.endress.com/cls82d](http://www.endress.com/cls82d)



Technical Information TI01188C

**Oxygen sensors****Oxymax COS22D**

- Sterilizable sensor for dissolved oxygen
- With Memosens technology or as an analog sensor
- Product Configurator on the product page: [www.endress.com/cos22d](http://www.endress.com/cos22d)



Technical Information TI00446C

**Oxymax COS51D**

- Amperometric sensor for dissolved oxygen
- With Memosens technology
- Product Configurator on the product page: [www.endress.com/cos51d](http://www.endress.com/cos51d)



Technical Information TI00413C

**Oxymax COS61D**

- Optical oxygen sensor for drinking water and industrial water measurement
- Measuring principle: quenching
- With Memosens technology
- Product Configurator on the product page: [www.endress.com/cos61d](http://www.endress.com/cos61d)



Technical Information TI00387C

**Memosens COS81D**

- Sterilizable, optical sensor for dissolved oxygen
- With Memosens technology
- Product Configurator on the product page: [www.endress.com/cos81d](http://www.endress.com/cos81d)



Technical Information TI01201C

**Disinfection sensors****CCS142D**

- Membrane-covered amperometric sensor for free chlorine
- Measuring range 0.01 to 20 mg/l
- With Memosens technology
- Product Configurator on the product page: [www.endress.com/ccs142d](http://www.endress.com/ccs142d)



Technical Information TI00419C

**Ion-selective sensors****ISEmax CAS40D**

- Ion selective sensors
- Product Configurator on the product page: [www.endress.com/cas40d](http://www.endress.com/cas40d)



Technical Information TI00491C

### Turbidity sensors

#### Turbimax CUS51D

- For nephelometric measurements of turbidity and solids in wastewater
- 4-beam scattered light method
- With Memosens technology
- Product Configurator on the product page: [www.endress.com/cus51d](http://www.endress.com/cus51d)



Technical Information TI00461C

#### Turbimax CUS52D

- Hygienic Memosens sensor for turbidity measurement in drinking water, process water and in utilities
- With Memosens technology
- Product Configurator on the product page: [www.endress.com/cus52d](http://www.endress.com/cus52d)



Technical Information TI01136C

### SAC and nitrate sensors

#### Viomax CAS51D

- SAC and nitrate measurement in drinking water and wastewater
- With Memosens technology
- Product Configurator on the product page: [www.endress.com/cas51d](http://www.endress.com/cas51d)



Technical Information TI00459C

### Interface measurement

#### Turbimax CUS71D

- Immersion sensor for interface measurement
- Ultrasonic interface sensor
- Product Configurator on the product page: [www.endress.com/cus71d](http://www.endress.com/cus71d)



Technical Information TI00490C

---

### Additional functionality

#### Hardware extension modules

##### Kit, extension module AOR

- 2 x relay, 2 x 0/4 to 20 mA analog output
- Order No. 71111053

##### Kit, extension module 2R

- 2 x relay
- Order No. 71125375

##### Kit, extension module 4R

- 4 x relay
- Order No. 71125376

##### Kit, extension module 2AO

- 2 x 0/4 to 20 mA analog output
- Order No. 71135632

##### Kit, extension module 4AO

- 4 x analog output 0/4 to 20 mA
- Order No. 71135633

##### Kit, extension module 2DS

- 2 x digital sensor, Memosens
- Order No. 71135631

##### Kit, extension module 2AI

- 2 x 0/4 to 20 mA analog input
- Order No. 71135639

##### Kit, extension module DIO

- 2 x digital input
- 2 x digital output
- Auxiliary voltage supply for digital output
- Order No. 71135638

**Kit, extension module 485**

- Ethernet configuration
- Can be extended to PROFIBUS DP or Modbus RS485 or Modbus TCP or EtherNet/IP. This requires an additional activation code which can be ordered separately.
- Order No. 71135634

**Kit, extension module ETH**

- Ethernet configuration
- Can be extended to Modbus TCP or EtherNet/IP. This requires an additional activation code which can be ordered separately.
- Order No. 71279810

**Upgrade kit, extension module 485 with PROFIBUS DP**

- Extension module 485
- PROFIBUS DP (+ Ethernet configuration)
- Order No. 71140888

**Upgrade kit, extension module 485 with Modbus RS485**

- Extension module 485
- Modbus RS485 (+ Ethernet configuration)
- Order No. 71140889

**Upgrade kit, extension module 485 with Modbus TCP**

- Extension module 485
- Modbus TCP (+ Ethernet configuration)
- Order No. 71140890

**Upgrade kit, extension module 485 with EtherNet/IP**

- Extension module 485
- EtherNet/IP (+ Ethernet configuration)
- Order No. 71219868

**Upgrade kit, extension module ETH with Modbus TCP**

- Extension module ETH
- Modbus TCP (+ Ethernet configuration)
- Order No. 71279809

**Upgrade kit, extension module ETH with EtherNet/IP**

- Extension module ETH
- EtherNet/IP (+ Ethernet configuration)
- Order No. 71279812

**Firmware and activation codes****SD card with Liquiline firmware**

- Industrial Flash Drive, 1 GB
- Order No. 71127100



You must quote the serial number of the device when ordering the activation code.

**Activation code for digital HART communication**

Order No. 71128428

**Activation code for PROFIBUS DP**

Order No. 71135635

**Activation code for Modbus RS485**

Order No. 71135636

**Activation code for Modbus TCP for module 485**

Order No. 71135637

**Activation code for EtherNet/IP for module 485**

Order No. 71219871

**Activation code for Modbus TCP for module ETH**

Order No. 71279813

**Activation code for EtherNet/IP for module ETH**

Order No. 71279830

**Kit CM442: activation code for 2nd digital sensor input**

Order No. 71114663

**Kit CM444/CM448: upgrade code for 2 x 0/4 to 20 mA for BASE-E**

Order No. 71140891

**Activation code for feedforward control**

- Requires current input or fieldbus communication
- Order No. 71211288

**Activation code for measuring range switch**

- Requires digital inputs or fieldbus communication
- Order No. 71211289

**Activation code for ChemocleanPlus**

- Requires relays or digital outputs or fieldbus communication and optional digital inputs
- Order No. 71239104

**Activation code for Heartbeat Verification and Monitoring**

Order No. 71367524

**Activation code for ion exchanger operating time**

- Mathematical function
- Order No. 71367531

**Activation code for mathematics**

- Formula editor
- Order No. 71367541

**Activation code for remote calibration interface**

Order No. 71367542

**Software****Memobase Plus CYZ71D**

- PC software to support laboratory calibration
- Visualization and documentation of sensor management
- Sensor calibrations stored in database
- Product Configurator on the product page: [www.endress.com/cyz71d](http://www.endress.com/cyz71d)



Technical Information TI00502C

**Field Data Manager Software MS20**

- PC software for central data management
- Visualization of series of measurements and logbook events
- SQL database for secure data storage

**Other accessories****External display<sup>3)</sup>****Graphic display**

- For installation in the control cabinet door or panel
- Order No. 71185295

**Service display**

- Portable, for commissioning
- Order No. 71185296

**SD card**

- Industrial Flash Drive, 1 GB
- Weight: 2 g
- Order No. 71110815

**M12 built-in socket and cable junction with Velcro strip****Kit CM42/CM442/CM444/CM448: external CDI socket**

- Socket with terminated connecting cables and counter nut
- Order No. 51517507

**Kit CM442/CM444/CM448/CSF48: M12 built-in socket for digital sensors**

- Pre-terminated
- Order No. 71107456

**Kit CM442/CM444/CM448/CSF48: M12 built-in socket for PROFIBUS DP/Modbus RS485**

- B-coded, pre-terminated
- Order No. 71140892

<sup>3)</sup> The external display can be selected as an option in the product structure or ordered subsequently as an accessory.

**Kit CM442/CM444/CM448/CSF48: M12 built-in socket for Ethernet**

- D-coded, pre-terminated
- Order No. 71140893

**Kit: external CDI socket, complete**

- Retrofit kit for CDI interface, with terminated connecting cables
- Order No. 51517507

**Cable junction with Velcro strip**

- 4 pieces, for sensor cable
- Order No. 71092051

**Communication-specific accessories****Commubox FXA191**

- Intrinsically safe HART communication with FieldCare via the RS232C interface
- Transforms HART signals on RS 232C interface



Technical Information TI00237F

**Commubox FXA195**

Intrinsically safe HART communication with FieldCare via the USB port



Technical Information TI00404F

**Commubox FXA291**

Connects the CDI interface of measuring devices with the USB port of the computer or laptop



Technical Information TI00405C

**Wireless HART adapter SWA70**

- Wireless device connection
- Easily integrated, offers data protection and transmission safety, can be operated in parallel with other wireless networks, minimum cabling complexity



Technical Information TI00061S

**Fieldgate FXA320**

Gateway for the remote interrogation of 4-20 mA measuring devices via a Web browser



Technical Information TI00025S

**FieldXpert SFX100**

Compact, flexible and robust industrial handheld terminal for remote configuration and for obtaining measured values via the HART current output



Operating Instructions BA00060S

**System components****RIA14, RIA16**

- Field display unit for integration into 4-20 mA circuits
- RIA14 in flameproof metal enclosure



Technical Information TI00143R and TI00144R

**RIA15**

- Process display unit, Digital display unit for integration into 4-20 mA circuits
- Panel mounting
- With optional HART communication



Technical Information TI01043K

---

[www.addresses.endress.com](http://www.addresses.endress.com)

---