



Updated SERIES CLS200

Samples Available Now

Compact Loop System, Providing Powerful Control in a 1/8 DIN Package



Watlow's SERIES CLS200 is a powerful line of controllers, combining performance and flexibility with compact design. The 4, 8 and 16 loop versions provide complete controller solutions for a broad range of applications. Support for multiple types of sensor inputs is available, including thermocouples, RTDs, linear voltage, current and frequency. Each controller includes built-in serial communications for computer interface and data acquisition. Optional programmable ramp and soak features allow complex batch processing and sequencing. An enhanced feature option offers cascade control, ratio control, differential control, process variable retransmit and remote analog set point.

The SERIES CLS200 controllers are UL® and C-UL® listed, RoHS by design and meet the requirements of the European Community EMC Directive and carry the CE mark.

Features and Benefits

PID control of up to 16 heat and cool loops

- Minimizes panel space per loop
- Reduces installation time
- Increases reliability: fewer parts means fewer failures

Auto-tune

- Requires less time tuning
- Achieves excellent control with less expertise

Menu-guided operation with full text display

- Allows quick setup of the controller
- Simplifies operation

Eight jobs stored and recalled

- Changes quickly from one process to another

Multiple and mixed inputs

- Accepts combinations of thermocouples, RTDs, linear dc voltage and linear dc current sensors
- Reduces learning curve and inventory

Sensor failure detection

- Reduces time troubleshooting reversed, shorted and open sensors

High/low process and deviation alarms for each input

- Integrates as needed with other automation controllers

34 digital outputs

- Provides flexible configuration
- Allows use of outputs as needed for control and alarms

EIA/TIA-232 and 485 communications

- Connects to software for easy operation
- Allows integration with controllers and software

Firmware Options

Choose firmware with the features needed for the application:

- Standard—includes closed-loop PID control, auto-tune, alarms, job memory and failed sensor detection.
- Ramp and soak—includes the standard firmware features with the addition of ramp and soak and process variable retransmit. Each channel can be configured for standard PID control or ramp and soak operation. Unused control outputs on any channel can be configured to retransmit a process value.
- Enhanced features— includes the standard firmware features with the addition of process variable retransmit, remote analog set point, cascade control, ratio control and differential control algorithms. Each channel can be configured for standard PID controller or one of the other control algorithms. Each channel of cascade control or remote analog set point requires two controller channels. Unused control outputs on any channel can be configured to retransmit a process value.
- Custom— application-specific, engineered solutions are available. Contact your Watlow representative.

Digital Input/Output Options

Controllers with the mass termination option for digital I/O termination have a 50-pin SCSI connector which allows access to all digital inputs and outputs. SCSI cables and the

TB50 digital I/O termination board options are offered to allow connection of field wiring.

Four and eight loop controllers can be configured with screw terminal connections on the back for connecting digital inputs and outputs, but this limits access to 15 outputs (10 of which can be used for control loops) and three inputs.

Because the SERIES CLS200 has no onboard analog outputs, applications that use process variable retransmit typically require one SDAC module per retransmitted signal.

DAC and SDAC Modules

The optional DAC and SDAC modules are available for Watlow SERIES CLS200 controllers.

DAC

The DAC (digital to analog converter) converts one or two of the controller's distributed zero crossing (DZC) output signals to analog signals. Each output is field configurable for 4-20mVDC, 0-5VDC or 0-10VDC.

SDAC

The SDAC (serial digital to analog converter) converts one controller output to a precise analog voltage or current signal. The unit is typically used for process variable retransmit, open-loop control, motor or belt speed control, or phase-angle fired SCR power controllers. The SDAC bears the CE mark and is UL® and C-UL® listed.

Dimensional Drawings

Figure 1 - TB18 Screw Terminals
Digital I/O Termination Option Shown

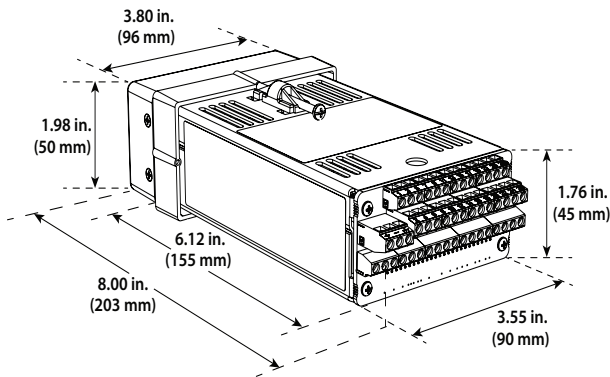

Figure 2 - TB50 Terminal Board Option

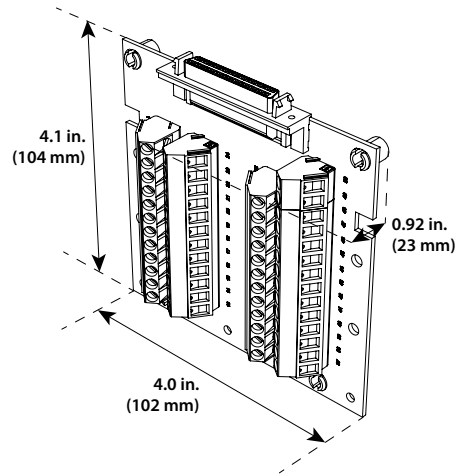
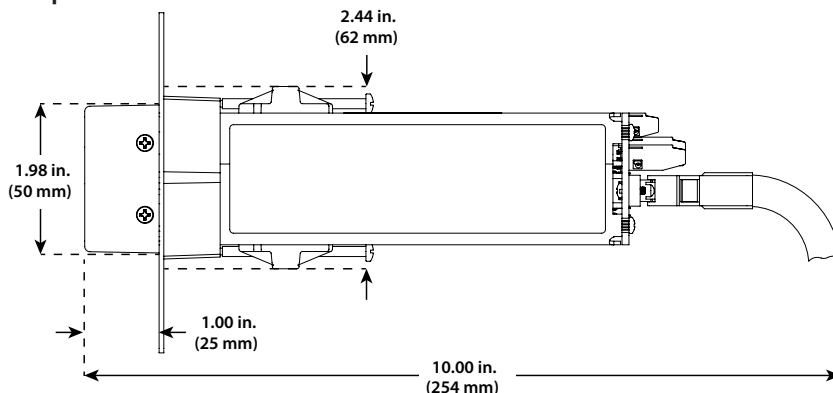

Figure 3 - Mass Termination (SCSI) Digital I/O Termination and Cable Options



Note: Overall length in the application depends on the *Digital I/O Termination* option and bend radius of wiring and cables used.

CLS200 Specifications

Operator Interface

- 32-character vacuum fluorescent display
- 8-key keypad to access guided menus and prompts, enter passkey sequence, set values, switch between single channel and multiple channel displays
- Controller configuration can be loaded via serial communication

Analog Inputs

- 4-loop model: 4 differential inputs
- 8-loop model: 8 differential inputs
- 16-loop model: 16 single-ended inputs

Analog Over Voltage Protection

- $\pm 20V$ referenced to digital ground

Maximum Common Mode Voltage

- 5V input to input or input to analog common (4- and 8-loop models)

Common Mode Rejection (CMR)

- For inputs that do not exceed $\pm 5V$, $>60dB$ dc to 1kHz and 120dB at selected line frequency

Noise Rejection

- 120dB at 60Hz

Sensors/Inputs

- Thermocouples: user-selectable type, direct connection, linearization, reference junction compensation, reversed and shorted thermocouple detection and upscale break protection with output averaging
- RTD: (4 and 8 loop models only) 2- or 3-wire, platinum, $100\Omega @ 0^\circ C$, DIN 0.003850 $\Omega/\Omega/^\circ C$ curve, user-selectable range. Two ranges offer different resolutions. Requires scaling resistors. See ordering information.
- Linear: current and voltage signals from linear transmitters
- Pulse input

Input Range and Accuracy

Sensor	Range ($^\circ C$)	Range ($^\circ F$)	Accuracy
Type B	66 to 1760 $^\circ C$	150 to 3200 $^\circ F$	$\pm 4.0^\circ C$
Type E	-200 to 787 $^\circ C$	-328 to 1448 $^\circ F$	$\pm 1.0^\circ C$
Type J	-212 to 760 $^\circ C$	-350 to 1400 $^\circ F$	$\pm 1.2^\circ C$
Type K	-268 to 1371 $^\circ C$	-450 to 2500 $^\circ F$	$\pm 1.3^\circ C$
Type R	-18 to 1766 $^\circ C$	0 to 3210 $^\circ F$	$\pm 2.8^\circ C$
Type S	-18 to 1760 $^\circ C$	0 to 3200 $^\circ F$	$\pm 2.8^\circ C$
Type T	-268 to 399 $^\circ C$	-450 to 750 $^\circ F$	$\pm 1.6^\circ C$

RTDs available on CLS204 and CLS208 only.

Sensor	Range ($^\circ C$)	Range ($^\circ F$)	Accuracy
RTD1	-100 to 275 $^\circ C$	-148 to 527 $^\circ F$	$\pm 1.1^\circ C$
RTD2	-120 to 840 $^\circ C$	-184 to 1544 $^\circ F$	$\pm 1.6^\circ C$

Note: Accuracy @ 25 $^\circ C$ ambient. Valid for 10 to 100 percent of span except Type B, which is specified for 800 $^\circ F$ to 3200 $^\circ F$. RTD.

Linear Voltage and Current Inputs

Requires scaling resistors. See ordering information.

0-20mAVDC/4-20mAVDC

0-5VDC

0-10VDC

Temperature coefficient: 40ppm/ $^\circ C$

Other ranges available. Contact factory.

Pulse Input

- One TTL-level square wave input up to 2kHz

Input Sampling Rate at 60Hz

Each channel has the following scans per second:

- 4-loop model: 6 samples per second, (update time: 0.167 sec.)
- 8-loop model: 3 samples per second, (update time: 0.333 sec.)
- 16-loop model: 1.5 samples per second, (update time: 0.667 sec.)

Internal Measurement Resolution

- 0.006 percent, greater than 14 bits

Calibration

- Automatic zero and full scale

Digital Inputs

- TTL-level used for selecting recipes or jobs, or R/S triggers
- 8 digital inputs and 1 pulse input with mass termination (SCSI) digital I/O termination and TB50 terminal board options
- 2 digital inputs and 1 pulse input with screw terminal (TB18) digital I/O termination option

Digital Outputs

- 34 digital outputs with mass termination (SCSI) digital I/O termination and TB50 terminal board options
- 11 control and alarm outputs with screw terminal (TB18) digital I/O termination option
- 1 or 2 control outputs are user assigned for each loop
- Each control output can be configured for on-off time proportioning, or distributed zero crossing
- Outputs sink up to 60mA each at 5VDC
- 350mA at 5VDC available from on-board supply

Alarm Outputs

- Independent process and deviation alarms for each channel
- Alarms can operate any output not used for control
- User-programmable deadband, delay and startup suppression
- Global alarm output activates when any alarm occurs
- Watchdog output indicates controller is functioning correctly

Serial Interface

- EIA/TIA-232 or EIA/TIA-485

Baud Rate

- 2400, 9600 or 19200, user-selectable

Communications Protocols

- Form of ANSI X3.28-1976, (D1, F1) compatible with Allen-Bradley PLC/2
- Modbus[®] RTU

Line Voltage/Power

- 15 to 24VDC $\pm 3VDC @ 1A$ (maximum), 300mA (no load)

Agency Approvals

- UL[®], C-UL[®] listed: UL[®] 61010-1 safety requirements for measurement, control and laboratory equipment
- CE Mark: See Declaration of Conformity for details
- RoHS by design

Ordering Information

Instructions: Choose one option for each feature.

✓	Number of Loops
	4 loops
	8 loops
	16 loops

✓	Firmware
	Standard
	Ramp and soak
	Enhanced features
	Custom—contact factory

✓	Digital I/O Termination
	Screw terminals (TB18)
	Mass termination (SCSI)

✓	Digital I/O Termination Board Accessory
	None
	TB50 terminal board

✓	Digital I/O Termination Cable Accessory
	None
	3-foot SCSI cable
	3-foot SCSI cable with right angle connector

✓	Serial Communication Jumper Settings
	EIA/TIA-232
	EIA/TIA-485, not terminated
	EIA/TIA-485, terminated

✓	Serial Communication Cable
	None
	10-foot communication cable (DB-9 female/bare wires)

✓	Mounting Hardware
	Plastic collar and screw clips

✓	Customer Specific Options
	None
	Contact factory

Analog Input Scaling	
	Standard units accept thermocouple on all loops. Controllers can be equipped with resistors to scale signals for various types of sensors. These resistors must be factory installed. Contact your Watlow sales representative for other types of sensor. Sixteen loop controllers cannot accept RTD sensors.

Note: To obtain a part number for your choice of options, communicate your selections to your Watlow sales representative who will provide a part number to you.

Watlow® is a registered trademark of Watlow Electric Manufacturing Company.
UL® and cUL® are registered trademarks of Underwriter's Laboratories, Inc.
Modbus® is a trademark of Schneider Automation Incorporated.

Powered by Possibility



To be automatically connected to the nearest
North American Technical Sales Office:
1-800-WATLOW2 • www.watlow.com
inquiry@watlow.com

International Technical Sales Offices:

Austria	+43 6244 20129 0	India	+91 40 6661 2700
China	+86 21 3532 8532	Italy	+39 02 458 8841
France	+33 1 41 32 79 70	Japan	+81 3 3518 6630
Germany	+49 7253 9400 0	Korea	+82 2 2169 2600

Mexico	+52 442 256 2200
Singapore	+65 6773 9488
Spain	+34 91 675 1292
Taiwan	+886 7 288 5168
UK	+44 115 964 0777



Not for New Designs

Compact Loop System, Providing Powerful Control in a 1/8 DIN Package

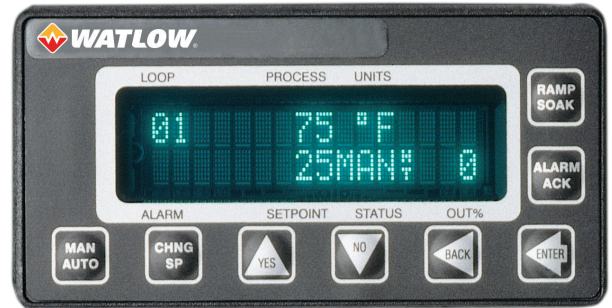

This specification sheet is for the old version of the SERIES CLS200 which is now "Not for new designs." Please see the specification sheet on the previous pages for the replacement SERIES CLS200 for all new designs.

Watlow's SERIES CLS200 is a powerful line of controllers, combining performance and flexibility with compact design. The 4, 8 and 16 loop versions provide complete controller solutions for a broad range of applications. Support for multiple types of sensor inputs is available, including thermocouples, RTDs, linear voltage, current and frequency. Each controller can operate as a stand-alone system, and includes built-in serial communications for computer interface and data acquisition. Optional programmable ramp and soak features allow complex batch processing and sequencing. An enhanced feature option offers cascade control, ratio control, differential control, process variable retransmit and remote analog set point.

The SERIES CLS200 controllers are UL® and C-UL® listed and meet the requirements of the European Community EMC Directive and carry the CE mark.

Features and Benefits

PID control of up to 16 heat and cool loops

- Minimizes panel space per loop
- Reduces installation time
- Increases reliability: fewer parts means fewer failures

Auto-tune

- Requires less time tuning
- Achieves excellent control with less expertise

Menu-guided operation with full text display

- Allows quick setup of the controller
- Simplifies operation

Eight jobs stored and recalled

- Changes quickly from one process to another

Multiple and mixed inputs

- Accepts combinations of thermocouples, RTDs, linear dc voltage and linear dc current sensors
- Reduces learning curve and inventory

Sensor failure detection

- Reduces time troubleshooting reversed, shorted and open sensors

High/low process and deviation alarms for each input

- Integrates as needed to integrate with PLC and other control elements

34 digital outputs

- Provides flexible configuration
- Allows use of outputs as needed for control and alarms

EIA/TIA-232 and 485 communications

- Connects to software for easy configuration and operation
- Allows integration with controllers and software

DAC and SDAC Modules

The optional DAC and SDAC modules are available for Watlow SERIES CLS200 controllers.

DAC

The DAC (digital to analog converter) converts one or two of the controller's distributed zero crossing (DZC) output signals to analog signals. Each output is field configurable for 4-20mVDC, 0-5VDC or 0-10VDC.

SDAC

The SDAC (serial digital to analog converter) converts one controller output to a precise analog voltage or current signal. The unit is typically used for process variable retransmit, open-loop control, motor or belt speed control, or phase-angle fired SCR power controllers. The SDAC bears the CE mark and is UL® and C-UL® listed.

Firmware Options

Choose firmware with the features needed for the application:

- Standard—includes closed-loop PID control, auto-tune, alarms, job memory and failed sensor detection.
- Ramp and soak—includes the standard firmware features with the addition of ramp and soak and process variable retransmit. Each channel can be configured for standard PID control or ramp and soak operation. Unused control outputs on any channel can be configured for retransmission.
- Enhanced features— includes the standard firmware features with the addition of process variable retransmit, remote analog set point, cascade control, ratio control and differential control algorithms. Each channel can be configured for standard PID controller or one of the other control algorithms. Each channel of cascade control or remote analog set point requires two controller channels. Unused control outputs on any channel can be configured for retransmit.

Because the SERIES CLS200 has no onboard analog outputs, applications that use process variable retransmit typically require one SDAC module per retransmitted signal.

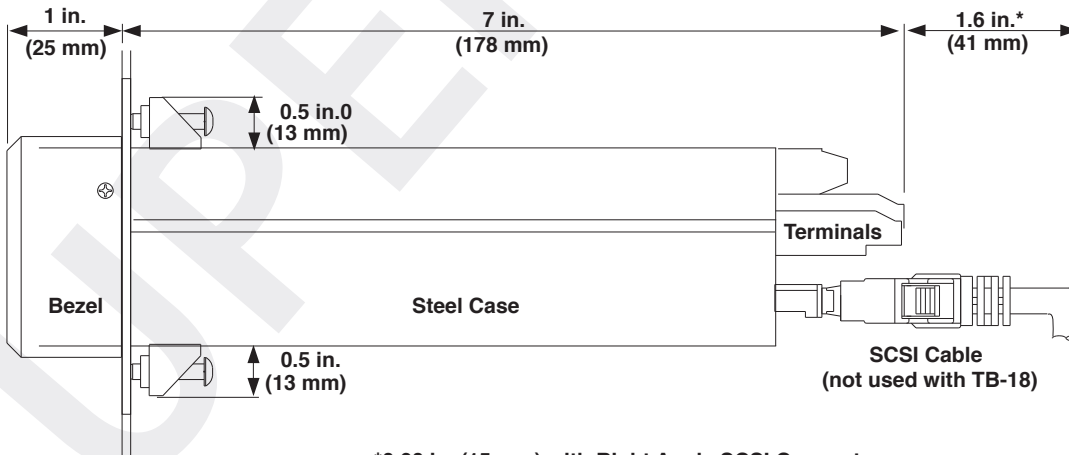
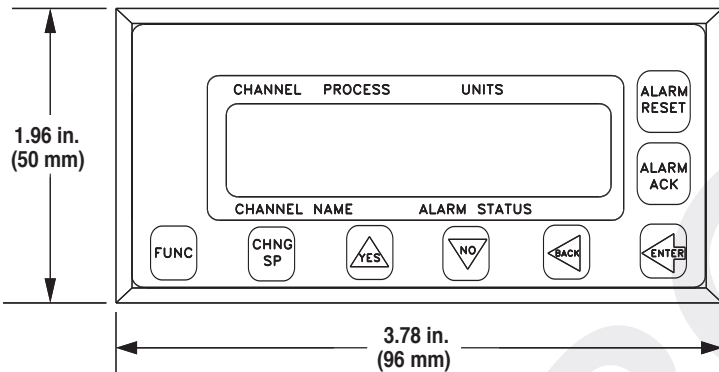

*0.60 in. (15 mm) with Right Angle SCSI Connector

CLS200 Specifications

Operator Interface

- 32-character vacuum fluorescent display
- 8-key keypad to access guided menus and prompts, enter passkey sequence, set values, switch between single channel and multiple channel displays
- Controller configuration can be loaded through the standard serial port

Analog Inputs

- CLS204 4 differential
- CLS208 8 differential
- CLS216 16 single-ended

Noise Rejection

- 120dB at 60Hz

Temperature Coefficient

- 40ppm/°C

Sensors/Inputs

- Thermocouples: user-selectable type, direct connection, linearization, reference junction compensation, reversed and shorted thermocouple detection and upscale break protection with output averaging
- RTD: (CLS204 and CLS208 only) 2- or 3-wire, platinum, 100Ω @ 0°C, DIN 0.003850Ω/Ω/°C curve, user-selectable range. Two user-selectable ranges offer different resolutions. Requires scaling resistors. See special/linear inputs in ordering information.
- Linear: current and voltage signals from linear transmitters
- Pulse input

Input Range and Accuracy

Sensor	Range (°C)	Range (°F)	Accuracy
Type B	66 to 1760°C	150 to 3200°F	±4.0°C
Type E	-200 to 787°C	-328 to 1448°F	±1.0°C
Type J	-212 to 760°C	-350 to 1400°F	±1.2°C
Type K	-268 to 1371°C	-450 to 2500°F	±1.3°C
Type R	-18 to 1766°C	0 to 3210°F	±2.8°C
Type S	-18 to 1760°C	0 to 3200°F	±2.8°C
Type T	-268 to 399°C	-450 to 750°F	±1.6°C

RTDs available on CLS204 and CLS208 only.

Sensor	Range (°C)	Range (°F)	Accuracy
RTD1	-100 to 275°C	-148 to 527°F	±1.1°C
RTD2	-120 to 840°C	-184 to 1544°F	±1.6°C

Note: Accuracy @ 25°C ambient. Valid for 10 to 100 percent of span except Type B, which is specified for 800°F to 3200°F. RTD.

Linear Voltage and Current Inputs

Requires scaling resistors. See special inputs in ordering information.

0-20mAVDC/4-20mAVDC

0-5VDC

0-10VDC

Other ranges available. Consult factory.

Pulse Input

- One TTL-level square wave input up to 2kHz

Input Sampling Rate at 60Hz

Each channel has the following scans per second:

- CLS204: 6 samples per second (update time: 0.167 sec.)
- CLS208: 3 samples per second, (update time: 0.333 sec.)
- CLS216: 1.5 samples per second, (update time: 0.667 sec.)

Internal Measurement Resolution

- 0.006 percent, greater than 14 bits

Calibration

- Automatic zero and full scale

Digital Inputs

- TTL-level used for selecting recipes or jobs, or R/S triggers
- 8 inputs and 1 pulse input with 50-pin terminal board option
- 2 inputs and pulse input or 3 inputs with 18-pin terminal block option

Digital Outputs

- 34 digital outputs are available with 50-pin terminal board option
- 10 control outputs with 18-pin terminal block option
- 1 or 2 control outputs are user assigned for each loop
- Each control output can be configured for on-off time proportioning, or distributed zero crossing
- Outputs sink up to 60mA each at 5VDC
- 350mA at 5VDC available from on-board supply

Alarm Outputs

- Independent process and deviation alarms for each channel
- Alarms can operate any output not used for control
- User-programmable deadband, delay and startup suppression
- Global alarm output activates when any alarm occurs
- Watchdog output indicates controller is functioning correctly

Serial Interface

- EIA/TIA-232 or EIA/TIA-485

Baud Rate

- 2400, 9600 or 19200, user-selectable

Communications Protocols

- Form of ANSI X3.28-1976, (D1, F1) compatible with Allen-Bradley PLC/2
- Modbus® RTU

Line Voltage/Power

- 15 to 24VDC ± 3VDC @ 1A (maximum), 300mA (no load)

Agency Approvals

- UL®, C-UL® listed: UL® 61010-1 safety requirements for measurement, control and laboratory equipment
- CE Mark: See Declaration of Conformity for details

Ordering Information

SERIES CLS200 Part Number

①	② ③ Number of Channels	④ Controller Type	⑤ Terminal Board	⑥ Power Supply	⑦ SCSI Cables	⑧ Serial Comm. Cables	⑨ Serial Comm. Jumper Settings	⑩ ⑪ Special Inputs and Other Custom Options
2								

② ③ Number of Channels
04 = 4 channel
08 = 8 channel
16 = 16 channel

④ Controller Type
1 = Standard EPROM
3 = Ramp and Soak
4 = Enhanced features
C = Custom firmware

⑤ Terminal Board
0 = SCSI connector only, user supplies cable and terminal board
1 = 18-pin terminal block (CLS204 and CLS208 only)
2 = 50-pin terminal block (includes 3 foot SCSI cable)

⑥ Power Supply
0 = No power supply
3 = 120/240VAC, 50/60Hz power supply adapter (15VDC @ 1.2A) CE, UL® Class 2 approved

⑦ SCSI Cables
0 = 3 foot SCSI cable with terminal board option 2 (no cable with options 0 or 1)
2 = 3 foot right angle SCSI cable

⑧ Serial Communication Cables
0 = No serial communication cable
1 = 10 foot serial communication cable (DB-9 female/bare wire)

⑨ Serial Communication Jumper Settings
0 = EIA/TIA-232
1 = EIA/TIA-485
2 = EIA/TIA-485 terminated

⑩ ⑪ Special Inputs and Other Custom Options
(Standard unit supports thermocouples and -10 to 60mV linear inputs. For other sensors, order special inputs. See below for ordering instructions. For CLS216 specify two digits, for CLS204 and CLS208 specify one digit.)
0 or 00 = Thermocouples and -10 to 60mV inputs only
N or NN = Number of current, voltage or RTD inputs (N is number)
XX = Factory assigned custom code (XX is two alphabetic characters)

Ordering Information

Special Input Type

① ② ③ ④ ⑤ CLSSI	⑥ ⑦ Special Input Type	⑧ Start Channel	⑨ End Channel

⑥ ⑦ Special Input Type
Not required for thermocouple sensor inputs.
20 = RTD 1: 0.1°, -148 to 527°F (-100 to 275°C) (Not available on CLS216)
21 = RTD 2: 1°, -184 to 1544°F (-120 to 840°C) (Not available on CLS216)
44 = 0-20mA dc/4-20mA dc
55 = 0-5VDC
56 = 0-10VDC

⑧ Start Channel
XX = Channel Number XX

⑨ End Channel
XX = Channel Number XX

Availability: Up to four weeks, depending on complexity and order release quantity. Contact factory for details.

Ordering Information

DAC/SDAC

① ② ③ DAC	④ Special Input Type	⑤ Start Channel

④ DAC/SDAC Type
1 = DAC with 2 each 0 to 5VDC outputs
2 = DAC with 2 each 0 to 10VDC outputs
3 = DAC with 2 each 4 to 20mA dc outputs
4 = Serial digital to analog converter (SDAC)

⑤ Power Supply
A = None
H = 120/240VAC, 50/60Hz power supply adapter, (15VDC @ 1.2A) powers up to 12 dual DAC modules
L = 120/240VAC, 50/60HZ power supply adapter (5VDC @ 3A) powers up to 10 SDAC modules

Watlow® is a registered trademark of Watlow Electric Manufacturing Company.
Windows® is a registered trademark of Microsoft Corporation.
UL® and C-UL® are registered trademarks of Underwriter's Laboratories, Inc.
Modbus® is a registered trademark of AEG Schneider Automation.

Powered by Possibility



To be automatically connected to the nearest North American Technical Sales Office:

1-800-WATLOW2 • www.watlow.com

International Technical Sales Offices:

Austria	+43 6244 20129 0	India	+91 40 6661 2700
China	+86 21 3532 8532	Italy	+39 02 458 8841
France	+33 1 41 32 79 70	Japan	+81 3 3518 6630
Germany	+49 7253 9400 0	Korea	+82 2 2169 2600

Mexico	+52 442 256 2200
Singapore	+65 6773 9488
Spain	+34 91 675 1292
Taiwan	+886 7 288 5168
UK	+44 115 964 0777