

Krautkrämer CL 5

Operating Manual
021-002-296 rev. 04



General Information 1

The CL 5 is an ultrasonic precision thickness measurement device. It's available with optional live A-Scan display, acoustic velocity measurement capability, and a data recorder in which as many 10,000 thickness measurements per file can be stored.

This chapter of your manual introduces the key features of the CL 5 and the contents of this operating manual. The next chapter explains the keypad functions and display-menu contents. Closely reviewing the material in these two chapters will help you make better use of the more detailed information found throughout the rest of this manual.

In this chapter, you'll learn

- How to install batteries or connect the AC power adapter to the instrument (Section 1.1)
- How to Power on and off the instrument (Section 1.2)
- The features of the instrument and base instrument package contents (Section 1.3)
- The general content of each chapter in this manual (Section 1.4)

1.1 Supplying Power to the CL 5

- The instrument is powered by a Lithium (Li) battery pack.
- It will also accept three "AA" size Alkaline, NiCAD, or NiMH (nickel metal hydride) battery types.
- The Lithium battery, which is recommended, will provide up to approximately 25 hours of service life. This pack (and *only* this pack) may be recharged in the instrument using the charger provided with your instrument.
- When other types of rechargeable batteries are used, they must be removed from the instrument for charging.

To install batteries, remove the battery-compartment cover as shown in Figure 1-1. After inserting the Li pack or three "AA" batteries according to the polarity indicated in the battery compartment, replace the compartment cover. Instructions on specifying battery type are found in Section 3.2.

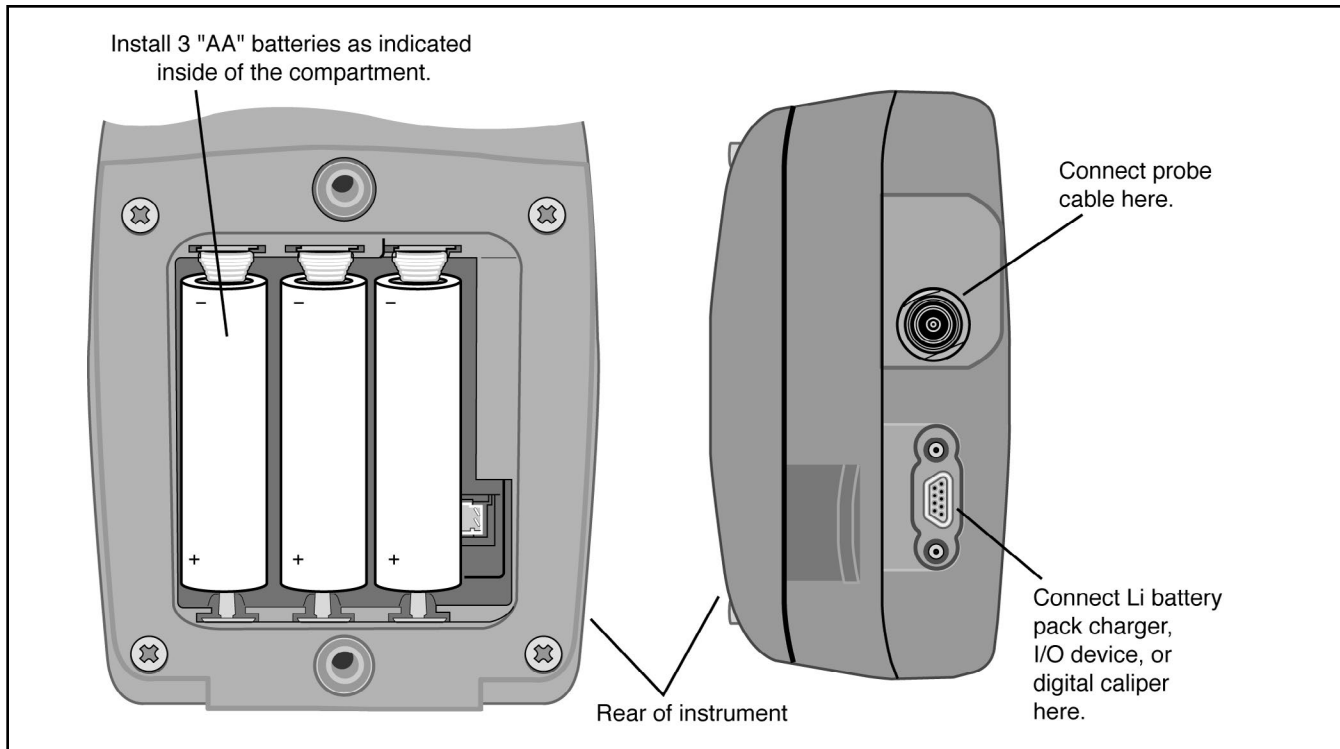



FIGURE 1-1—Insert batteries as shown here. Notice the location of the External Power Connector to which the instrument's Li battery pack's charger be connected.



Note:

When the battery indicator is in the last quarter as indicated by the display-screen symbol , replace the batteries as soon as possible. The CL 5 automatically shuts off when batteries are too weak for reliable operation. However, settings are saved and restored when the instrument is turned on again. When testing in remote locations, always carry spare batteries.

Note:

The instrument can be operated while the Li battery pack's charger is connected. This charger is connected to the instrument through the connector shown in Figure 1-1. When the charger is powering the instrument, **ACt** appears on the display screen. The charger may only be connected when the Waygate Technologies Li battery pack is installed in the instrument.

1.2 Powering On and Off the Instrument

After a power source has been provided, power on the instrument by pressing and holding  until the instrument turns on. Press and  hold when the instrument is on to turn it off.

1.3 Key Features of the CL 5

- Large Hollow/filled thickness digits
- Standard and Custom parameter setups
- Supports delay and contact probes
- Alphanumeric naming of data files
- Lockout feature with password access
- Lightweight – .75 lbs (.34 Kg)
- Large LCD Display with Backlight and Adjustable Contrast
- Approximately 25 hours life – with the Li battery pack or 3 “AA” alkaline batteries
- Easy-to-use, single-level menu system
- Multiple display-screen languages

- User-selectable measurement resolution to 0.0001 inch (0.001 mm)
- Normal (thickness), Min-Scan, Max-Scan, and Differential/Rate of Reduction Measurement Modes are Standard
- Optional Quality View Mode with Data Recorder Option and Custom Linear Files for storing thickness measurements from multiple locations, with different thicknesses and tolerances, for each item to be measured.
- Optional A-Scan provides A-Scan plus Thickness
- Optional Data Recorder stores up to 10,000 thickness measurements with A-Scan images attached in as many as 120 data recorder files
- Optional Velocity Measurement Mode includes an electronically connected digital caliper for exact measurement and automatic input of nominal thickness
- Field upgrades available via the Waygate Technologies web site
- Compatible with UltraMATE® and UltraMATE LITE® software programs

CL 5 Precision Thickness Measurement Base Instrument

Contents of the CL 5 Base Instrument

- CL 5 Instrument
- Lithium Battery Pack
- Lithium Battery Pack Recharger
- Plastic Carrying Case
- Wire Stand
- AC power supply
- Couplant Sample
- Firmware Upgrade USB Stick (requires Serial PC cable)
- Operating Manual
- Operating Instruction Card
- Certificate of Conformity

Instrument Options

- A-Scan Upgrade Option
- Data Recorder Upgrade Option
- Velocity Measurement Option

1.4 What's in this Manual

The CL 5 Operating Manual is divided into ten chapters. All chapters except 4 and 5 apply to all instruments. The last two sections of Chapter 4 apply only to instruments equipped with the A-Scan or Velocity measurement options. Chapter 5 applies only to instruments equipped with the Data Recorder option. Note that any CL 5 can be retrofitted to incorporate these options. Following is a summary of Chapters 1 through 10:

Chapter 1—General Introduction

- Supplying Power to the instrument
- Powering on and off the instrument

- Overview of instrument features
- Explanation of the operating manual contents

Chapter 2—Understanding the Keypad, Menu System, and Displays

- Operations performed by each key
- Navigating the display screens
- Overview of menu functions
- Explanation of display features (base model, data recorder, and A-Scan equipped instruments)
- Definition of icons

Chapter 3—Setting Up the CL 5

- Install a probe and configure the instrument by loading a setup file
- Set up the instrument display appearance (for base model and A-Scan equipped instruments) and make other configuration settings

- Adjust the instrument gain setting
- Specify the nominal material thickness
- Calibrate and zero the instrument/probe combination
- Set maximum and minimum alarm values
- Create and erase custom setup files
- Lock and unlock instrument controls

Chapter 4—Measuring Thickness

- Specify and use the Normal measurement mode (No A-Scan)
- Operate in Min-Scan and Max-Scan Measurement mode
- Operate in Differential/Rate of Reduction measurement mode
- Select and interpret the A-Scan plus Thickness measurement mode (Optional)
- Magnify the displayed A-Scan using the Zoom control

- Freeze the thickness reading and A-Scan
- Connect the digital caliper and measure acoustic velocity (Optional)
- Measure, evaluate and record thickness values from multiple locations on one item and store it in one file with Quality View Mode and Data Recorder (Optional)

Chapter 5—Using the Optional Data Recorder

- Create, recall, and delete data recorder files
- Store A-Scan and thickness readings in data recorder files
- Navigate data recorder file locations
- Attach notes to the data recorder file
- Print reports

Chapter 6—I/O Technical Details

- Configure the instrument to communicate with PCs and printers
- Thickness value format
- Remote control codes

Chapter 7—Specifications

Chapter 8—Maintenance

Chapter 9—Appendix

- Reset the operating software
- Upgrade the operating software
- EMC documentation
- How to obtain service

Chapter 10—Index

Understanding the Keypad, Menu System, and Displays **2**

The CL 5's display, keypad, and functional commands are easy to interpret and use. In this chapter you'll find a brief explanation of all display and keypad features. You'll also find references to manual sections where more detailed information is available.

Note that the CL 5's display screen contents vary depending on the optional features installed and the operational settings selected. Display screens shown in this chapter represent those found in all instrument configurations including:

- Base Model
- A-Scan Option Installed
- Data Recorder Option Installed
- A-Scan and Data Recorder Options Installed

2.1 Keypad Features

The instrument's keypad includes dedicated keys (CAL ON and MODE), arrow keys (↑, ↓, ←, →), and three virtual function keys (▲). Key functions are described in Figure 2-1.

2.2 Interpreting Display Screens

This section of your manual describes the layout of the CL 5's primary display modes including the:

- **Measurement Display Mode** – Indicates measured thickness, contains status icons, displays data recorder location and file name (when this option is installed and activated), and the live A-Scan display (when this option is installed and activated). Figure 2-2 shows four representative display screens.

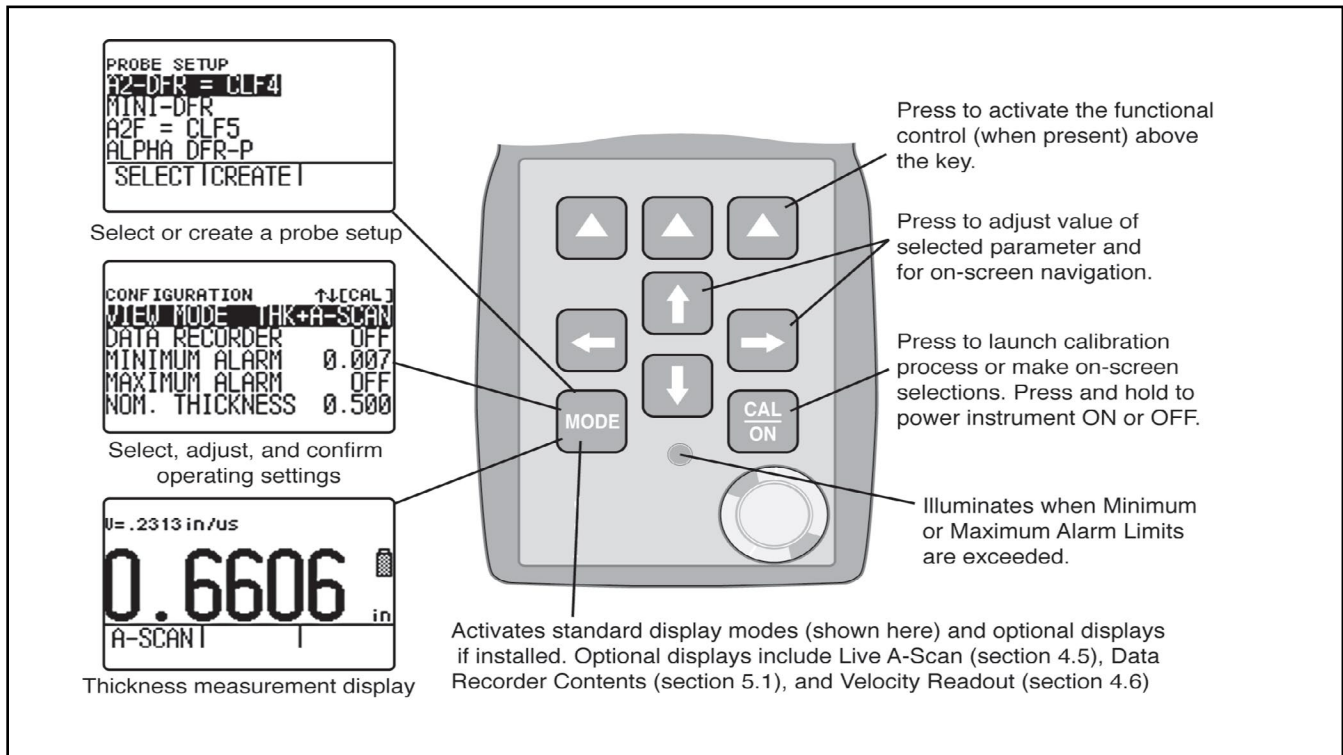

FIGURE 2-1—Key Functions

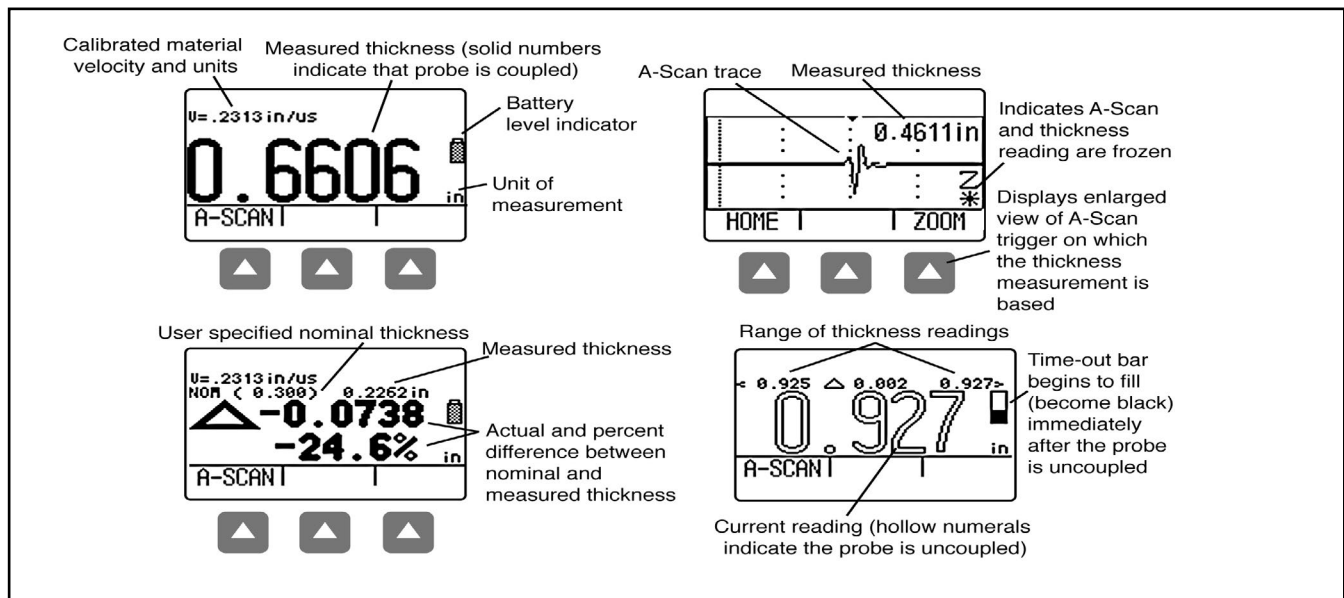



FIGURE 2-2—MEASUREMENT DISPLAY MODE – The display’s appearance varies based on installed instrument options as well as instrument display settings. NORMAL view mode is available in all instruments regardless of the installed options. Additional measurement view modes are available when the A-Scan or Data Recorder options are installed. Depending on the view selected, the display may contain the current thickness value, a live A-Scan, minimum thickness value, maximum thickness value, and differential value in the unit of measurement or as a percentage when compared to a nominal value.

- **Probe Setup Display Mode** – Allows the user to select a standard preloaded instrument setup (each matched to a specific probe model) or a custom user-defined setup. Custom Setups are created using this display screen. They can be downloaded to a PC using the UltraMATE® software package and then downloaded into any CL 5 instrument. The contents of a Custom Setup file vary depending on the instrument's configuration. See Section 3.5 for information on custom setups. (Figure 2-3).
- **File Display Mode** – Allows the user to create and store thickness readings in data recorder files. This feature is only available when the data recorder option is installed and activated. Accompanying A-Scans can be stored with thickness readings by holding  below the SEND Function for three seconds. (Figure 2-4)
- **Configuration Display Mode** – Instrument controls are accessed through this screen. The controls listed on the configuration display screen vary depending on the installed options. (Figure 2-5)

NOTE: A-Scan option must be active to store to data recorder.

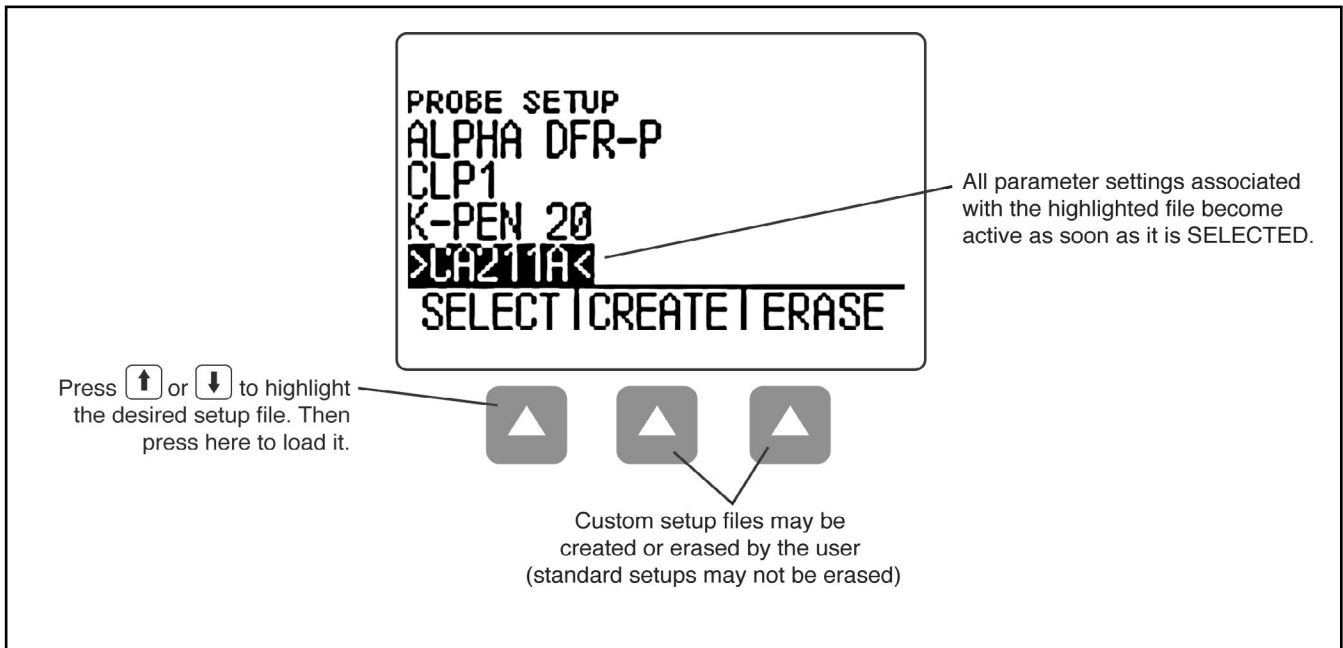

FIGURE 2-3—PROBE SETUP DISPLAY MODE – Allows selection of a preloaded or Custom Setup file, which automatically recalls all parameter settings. Note that Custom Setups can be downloaded from an UltraMate® equipped PC to any instrument, or created using this display (see Section 3.5 for information on Custom Setup files).

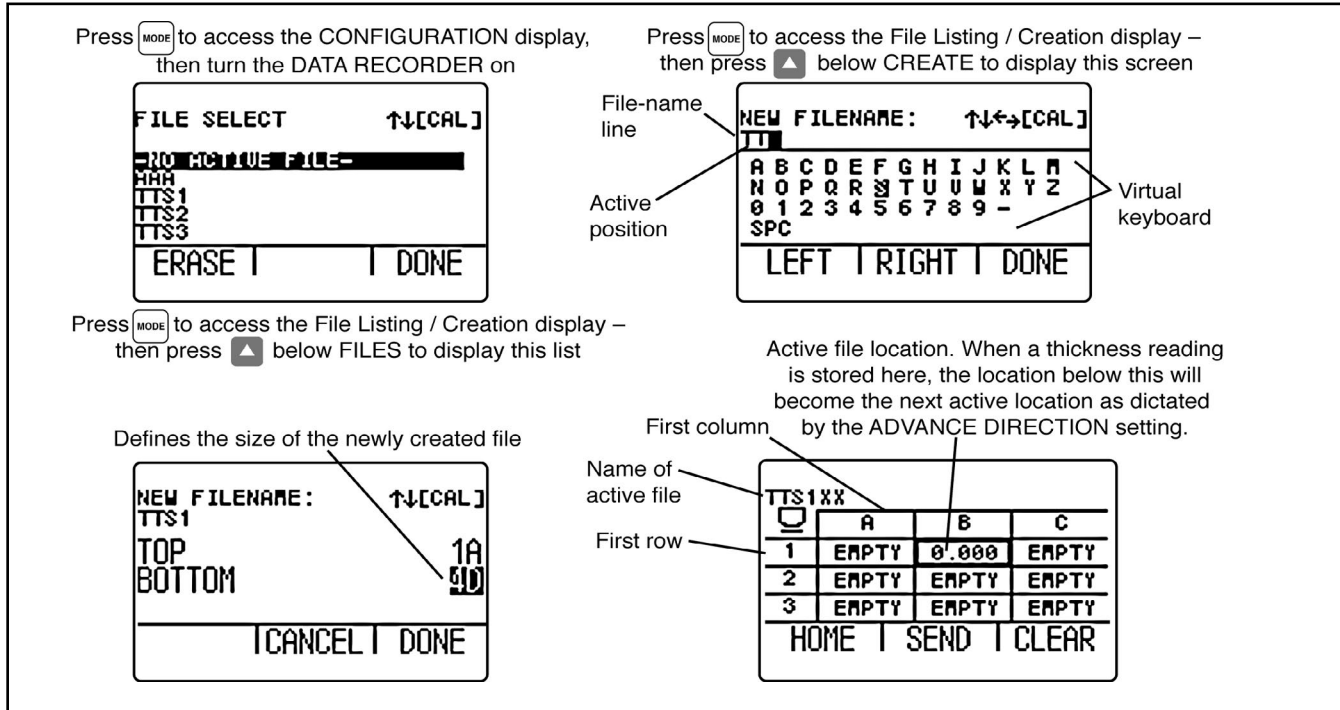

FIGURE 2-4—FILE DISPLAY MODE – When installed and activated, the data recorder option allows users to create data recorder files, store thickness readings (and accompanying A-Scans), and navigate through file contents as shown here. See Chapter 5 to work with Data Recorder files.

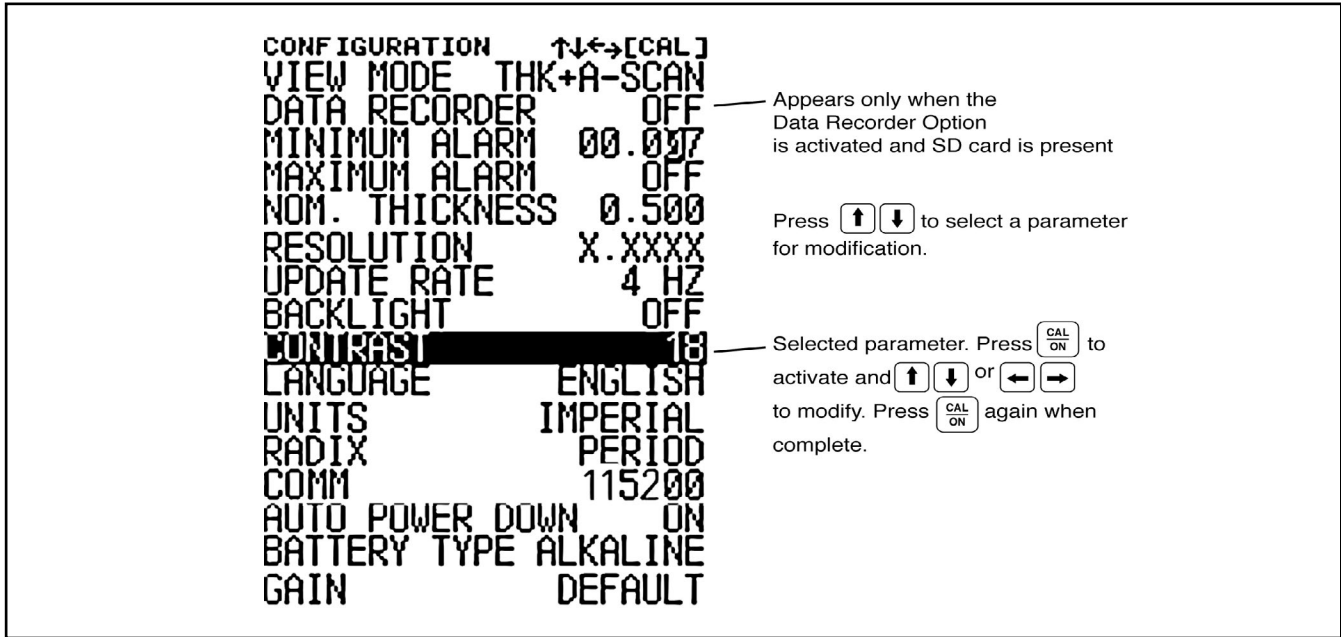



FIGURE 2-5—CONFIGURATION DISPLAY MODE – The contents of the Configuration display depend on the instrument’s installed-option configuration. All settings listed on the Configuration display are described in Section 2.3.

2.3 Working with the Configuration Display

The Configuration display is accessed by pressing . With this screen displayed, you can adjust most CL 5 controls.

VIEW MODE – In base-model units this parameter offers 4 settings. In A-Scan equipped instruments this parameter allows the measurement and live A-Scan to be displayed. In Data Recorder equipped instruments, Quality View is available. See Section 4.1 to select the view to be displayed.

DATA RECORDER – When the optional data recorder is installed, setting this parameter to ON activates the file recording capability and the data recorder file display.

MINIMUM ALARM – Enables and sets the minimum alarm value. (Section 3.4)



MAXIMUM ALARM – Enables and sets the maximum alarm value. (Section 3.4)

NOMINAL THICKNESS – Set the nominal thickness value that is then used to calculate and the differential and rate of reduction measurement values when selected by the VIEW MODE parameter. (Section 3.2.3)

RESOLUTION – Controls the format (number of decimal places) of the thickness measurement displayed, printed in a report, and stored in a Data Recorder file. (Section 3.2)

UPDATE RATE – Rate at which the measurement reading is updated. (Section 3.2.2)

BACKLIGHT – Turns the display's backlight feature to ON, OFF, or AUTO (AUTO switches backlighting on whenever a key is pressed or the probe is coupled)

CONTRAST – Sets the display's contrast level (select then press  or  to change contrast)

LANGUAGE – Sets the instrument display's language (Section 3.2)

UNITS – Sets the unit of measurement to inches or millimeters (Section 3.2)

RADIX – Selects a period (.) or comma (,) to be used as a decimal point (Section 3.2)

COMM – Specifies the baud rate of the attached printer or PC

AUTO POWER DOWN – Selects the battery-life saving ON, which powers down the instrument if no key presses or measurement occur for four minutes, or the OFF setting, which will only power down the instrument when  is pressed.

BATTERY TYPE – Select the installed battery type to ensure accurate remaining battery-life indication. Choose from Alkaline, NiMH, or NiCAD. (See Section 1.1 to install batteries)

GAIN – Selects the default or reduced level of gain corresponding to the active setup file (Section 3.2.1)

Setting Up the CL 5 **3**

Prior to measuring thickness, the instrument must be properly setup. This chapter explains the steps that must be taken prior to measurement, to ensure that the display appearance, ultrasonic settings, and measurement mode match the desired configuration. The steps described in this chapter apply to all instruments, regardless of whether or not they incorporate the A-Scan or Data Recorder options.

Most fundamental instrument parameters are automatically set to a default value based on the Setup file selected by the user. The instrument is supplied with standard Setup files, named to match the probe for which they are intended. Loading these standard setup files (or a Custom Setup file like the ones described in Section 3.5) is the first step to setting up the instrument.

In preparation for measuring thickness, this chapter explains how to

- Install a probe and configure the instrument by loading a Setup file (Section 3.1)
- Set up the instrument display appearance (Section 3.2)
- Set the instrument's Gain and Update Rate (Section 3.2)
- Calibrate the instrument/probe combination (Section 3.3)
- Set maximum and minimum alarm values (Section 3.4)
- Create and Erase Custom Setup Files (Section 3.5)
- Lock and unlock instrument controls (Section 3.6)

3.1 Connecting a Probe and Loading a Setup File

Prior to measuring thickness, you must connect a probe to the instrument and select a setup file that's compatible with the probe (Figure 3-1). The CL 5 supports delay line and contact probe types (see Chapter 7 for specifications).

Once a probe is connected, press  to activate the Probe Setup display. The Probe Setup display, which is shown in Figure 3-2, allows the user to select a standard or Custom Setup file (see Section 3.5 to create or erase Custom Setup files).

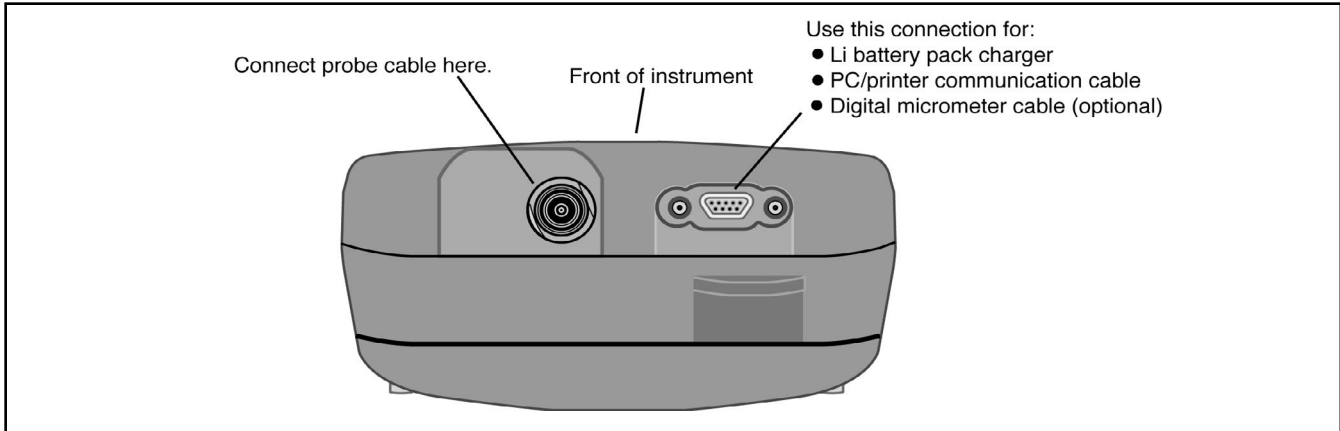

FIGURE 3-1—Connecting a Probe Cable

The following instrument settings are automatically adjusted when the Setup file is activated:

- View Mode
- Gain
- Measured Value display resolution
- Minimum Alarm Setting
- Maximum Alarm Setting
- Zero Offset – for contact probes only
- Velocity
- Nominal Thickness

 **Note:**

While Custom Setups can be created in any instrument, the parameter settings, which may be modified and then saved in a Custom Setup, depend on the instrument's configuration. In a base model instrument, only the setup name, material velocity value (determined via calibration), alarm thickness values, and UT settings related to the probe setup can be modified and stored in a custom setup.

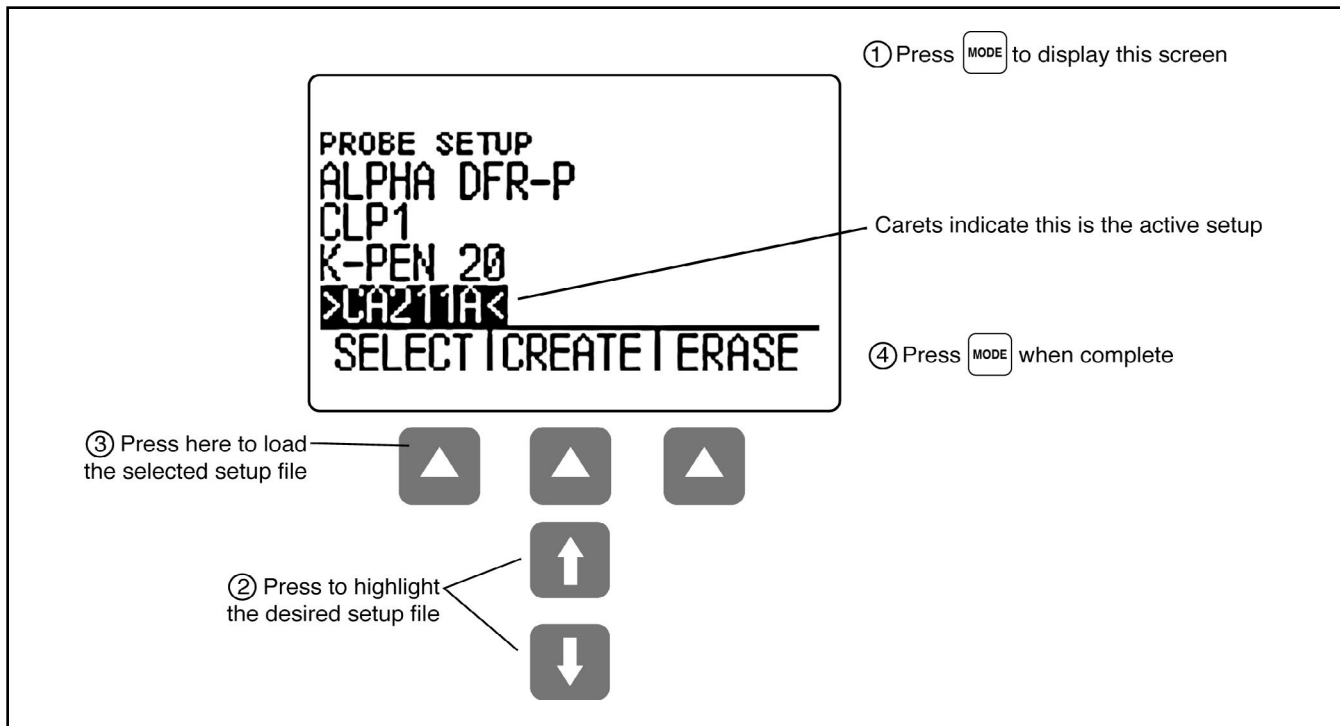

FIGURE 3-2—Selecting a Setup File

3.2 Configuring the Instrument



Prior to using the CL 5 to measure thickness, some or all of the following parameters must be specified using the Configuration display shown in Figure 3-3.

- Language – Set the displayed language to English, German, French, Spanish, Italian, etc.
- Units – Set the unit of measurement to inches or millimeters
- Resolution – Sets the number of decimal places to which thickness measurements are displayed
- Update Rate – Update the displayed measurement at a rate of 4 or 8 Hz
- Radix – Select a period (.) or comma (,) to be used as a decimal point
- Battery Type – Select from Alkaline, NiCAD, or NiMH

- Auto Power Down – Select ON to automatically turn the instrument off five minutes after the last key press (no data will be lost) or OFF to allow the instrument to remain on until manually powered off.
- Contrast – Adjusts the display contrast
- Backlight – Adjusts the display lighting (a setting of ON increases battery usage, a setting of AUTO causes backlighting to illuminate and remain on for Five Seconds after each key press.)

Each of these parameters is set the same way:

Step 1: Press  multiple times to access the display (shown in Figure 3-3).

Step 2: Press  or  to select each parameter you would like to modify.

Step 3: When the desired parameter is highlighted, press  to activate it.

Step 4: Press  or  to adjust the parameter's value.

Step 5: Press  when the parameter is set to the desired value.

The image shows a monochrome LCD screen displaying a configuration menu. The menu items and their current values are as follows:

- CONFIGURATION ↑↓←→[CAL]
- VIEW MODE THK+A-SCAN
- DATA RECORDER OFF
- MINIMUM ALARM 00.007
- MAXIMUM ALARM OFF
- NOM. THICKNESS 0.500
- RESOLUTION X.XXXX
- UPDATE RATE 4 HZ
- BACKLIGHT OFF
- CONTRAST 18
- LANGUAGE ENGLISH
- UNITS IMPERIAL
- RADIX PERIOD
- COMM 115200
- AUTO POWER DOWN ON
- BATTERY TYPE ALKALINE
- GAIN DEFAULT

Five numbered callouts provide instructions for navigating the menu:

- ① Press **MODE** to display this screen
- ② Press **↑** to select parameter for modification
- ③ Press **CAL ON** to activate the selected parameter
- ④ Press **←** or **→** to adjust the activated parameter
- ⑤ Press **CAL ON** to complete the modification

Below the menu, four directional arrow keys (up, down, left, right) are shown, with lines pointing to callouts 2 and 4.

FIGURE 3-3—Changing Parameter Settings



Step 6: Continue selecting other parameters for modification as outlined in Steps 2 through 5. When complete with all modifications, press  to return to the measurement display.

3.2.1 Setting Instrument Gain

Instrument gain level is set to either a DEFAULT value or to a noise-reducing LOW setting. To select the instrument gain setting

Step 1: Press .

Step 2: Select the GAIN control

Step 3: Press  to activate the control, then  or  to adjust the setting.



Step 4: Press  when the adjustment is complete.

3.2.2 Setting Update Rate

Measurements are updated at a rate of 4 or 8 Hz, as selected by the user. To select the measurement update rate:

Step 1: Press .

Step 2: Select the UPDATE RATE control.

Step 3: Press  to activate the control, then  or  to adjust the settings





Step 4: Press  when the adjustment is complete.

3.2.3 Specifying Nominal Thickness

When the VIEW parameter is set to DIFF/RR%, the displayed thickness includes two differential values (in the instrument's units and as a percentage) that represent the variation from user-specified nominal thickness (Section 4.4). Nominal thickness is also used to calculate material velocity when the velocity measurement option is installed. In VELOCITY view mode, nominal thickness can be manually input or directly measured using a connected digital micrometer (Section 4.6). To manually input or modify the nominal thickness:

Step 1: Press .

Step 2: Select the NOM THICKNESS control.

Step 3: Press  to activate the control, then  or  to adjust the selected place value and  or  to select another value.

Step 4:

NOTE: Nominal and Alarm values may be overridden in

Quality View Mode when a Custom Linear File is active (Data Recorder Option)

(NOM. THICKNESS N/A is displayed. This value cannot be changed.)

Press  when the adjustment is complete.

3.3 Instrument Calibration

Before measuring thickness with the CL 5, the instrument and connected probe must be calibrated. It's important that the setup file corresponding to the attached probe be selected prior to launching the calibration process.

Calibration requires the use of one or more standards of known thickness. When a contact probe is installed, either a one or two point calibration can be specified. Note that contact probe types require zeroing and the zeroing process is automatically accomplished as part of calibration. To calibrate the instrument, follow the instructions in Figure 3-4 and on your instrument's display screen.

 **Note:**

Proper calibration affects the accurate operation of the instrument. The instrument should be calibrated if there is a change in the type or temperature of the material being tested, if the attached probe is changed, after performing any parameter adjustment, or at intervals specified in your test procedures.

3.4 Setting the Maximum and Minimum Alarms

The CL 5 is equipped with a red LED (at the bottom center of the instrument's key pad) that illuminates whenever the user-inputted minimum or maximum

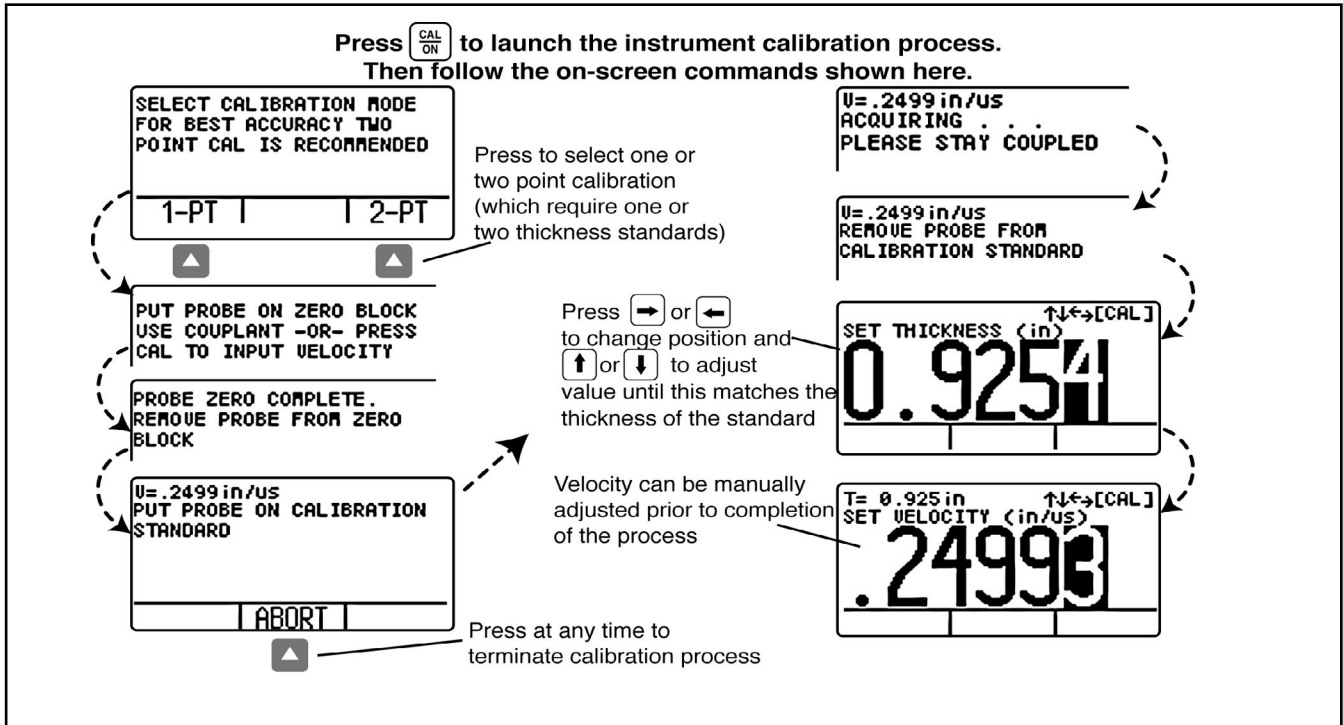



FIGURE 3-4—Instrument Calibration Procedure







alarm is violated. Note that the inputted alarm value will correspond to a thickness except when the VELOCITY measurement option is installed and activated. In this case the alarm settings will represent velocity values. To input a minimum or maximum alarm:

Step 1: Press  to access the Configuration display (shown in Figure 3-3).

Step 2: Press  or  to select

MINIMUM ALARM or MAXIMUM ALARM

Step 3: When the desired parameter is highlighted, press  to activate it.

Step 4: Press  or  to change the selected position in the alarm thickness and  or  to adjust the value of the selected position. To switch the alarm setting to OFF from any other value, simultaneously press  and .

Step 5: Press  when the alarm thickness is set to the desired value.

3.5 Creating and Erasing Custom Setup Files

After loading a Standard Setup and performing the necessary adjustments to optimize performance for a given application, the instrument settings can be stored and named as a Custom Setup file. The instrument is capable of storing up to 5 Custom Setup files, which can be erased at any time (Figure 3-5).

Custom Setups can be created from any CL 5 keypad. Custom Setups created using a base-model instrument include the following settings:

- User-assigned Custom Setup file name
- VELOCITY
- MINIMUM ALARM
- MAXIMUM ALARM

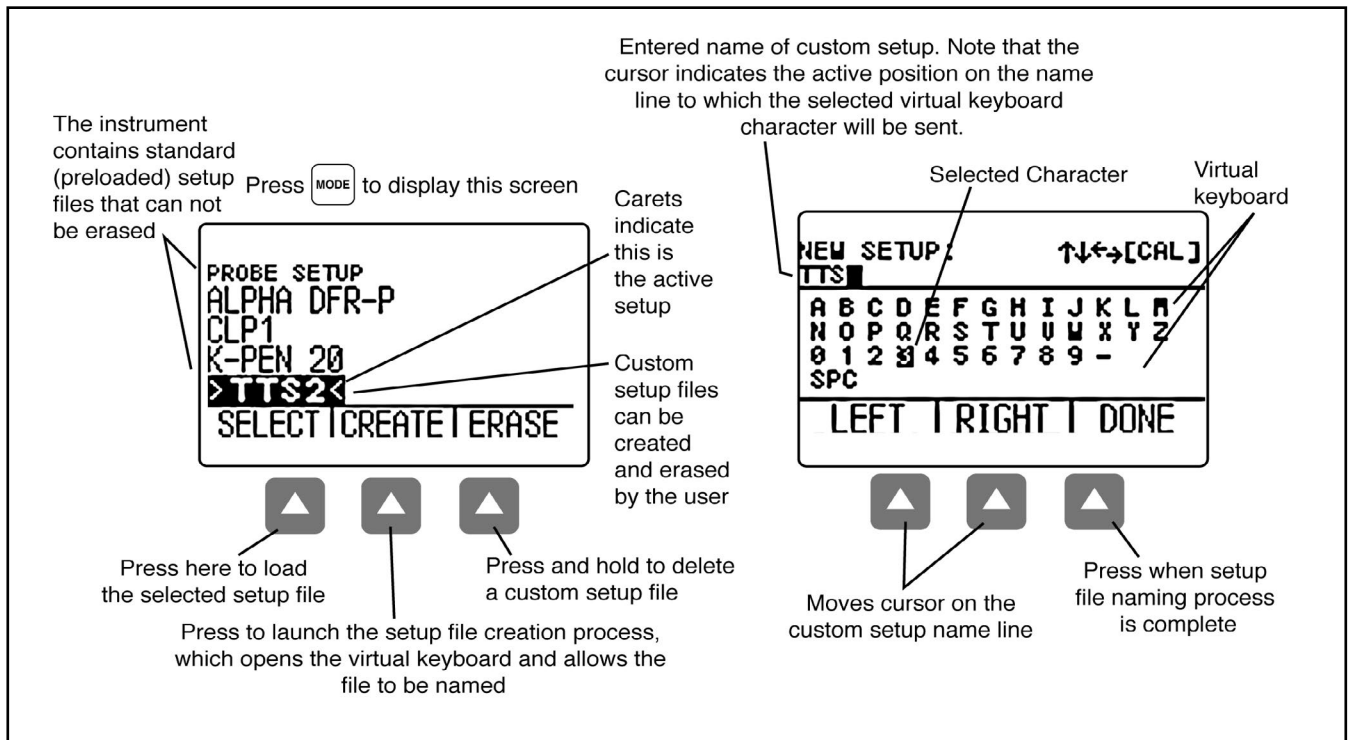

FIGURE 3-5—Follow this procedure to create or erase a Custom Setup file. Custom Setup file names may contain up to 16 characters.

Custom Setups created using instruments equipped with an optional A-Scan display store the same parameters as a base-model unit as well as settings that affect measurement. A full listing of parameter settings stored in Custom Setup files is found in Table 3-1.

Whenever a Standard or Custom Setup file is recalled, all of the instrument settings revert to those settings

stored in the file. Note that thickness measurements are part of Data Recorder files (see Chapter 5) and are not stored in Setup files.

Note:

UltraMATE can be used to transfer Custom Setup files to a PC where they are stored. The stored Setup file can then be downloaded to any CL 5.

Table 3-1	
CUSTOM SETUP FILE CONTENTS	
Custom Setup File Name	Nominal Thickness—when differential, %RR, or Velocity mode is selected
Velocity	Minimum Alarm Thickness
Gain	Maximum Alarm Thickness
Resolution of Displayed Values	Zero Offset
View Mode	

3.6 Locking and Unlocking Instrument Controls

Any instrument function can be made nonoperational (locked) using the lockout display. Note that this display is only accessible from the measurement screen. Follow the instructions in Figure 3-6 to access this display and lockout (or enable) some or all function keys.

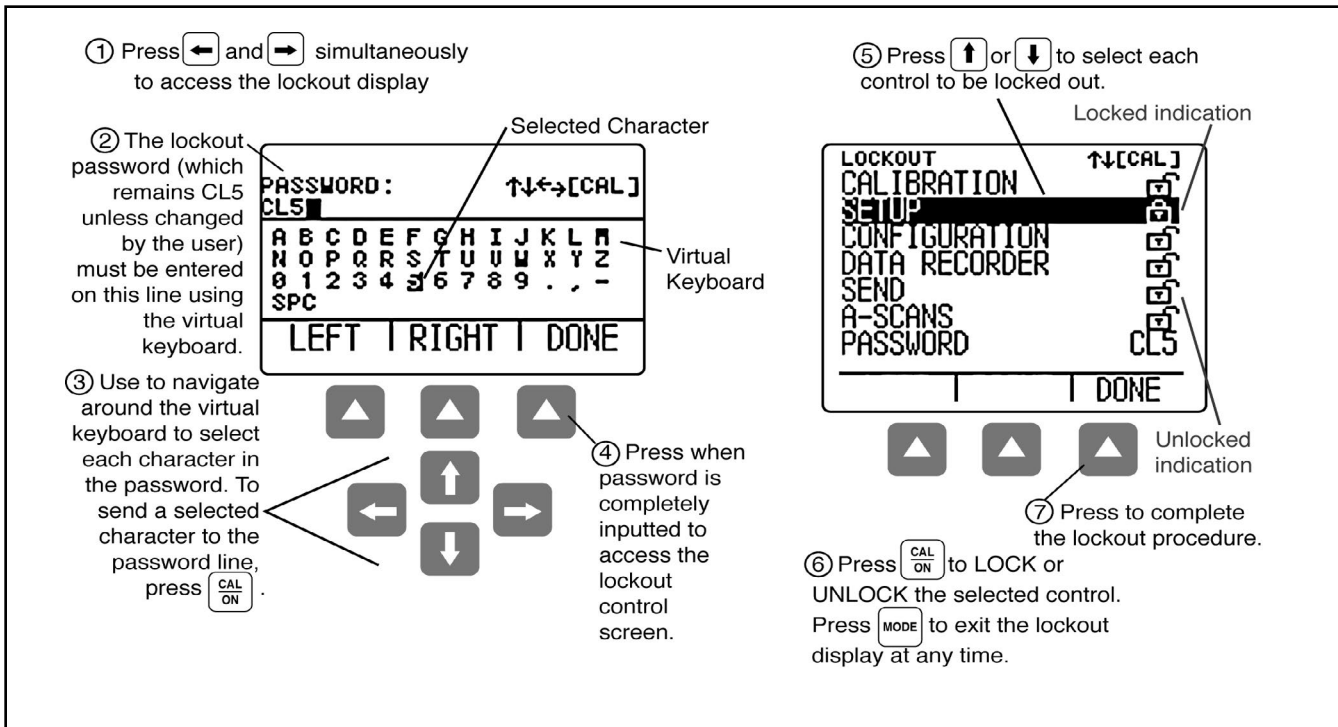

FIGURE 3-6—Procedure for locking and unlocking function keys

THIS PAGE LEFT INTENTIONALLY BLANK.

Measuring Thickness 4

After setting up the instrument, as described in Chapter 3, additional adjustments can be made to select the type of measurement made and the way in which it is displayed. In this chapter, you'll also find information related to configuring and working with the optional A-Scan display including how to:

- Select the measured value to view (Section 4.1)
- Work with Normal measurement mode (Section 4.2)
- Use the Min Scan and Max Scan measurement modes (Section 4.3)
- Interpret the Differential/Rate-of-Reduction measurement mode (Section 4.4)
- Measure and Evaluate multiple thickness points on the same workpiece and capture this data with Quality View Mode and Data Recorder Option (Section 4.5)
- Work with the optional Thickness + A-Scan measurement mode (Section 4.6)
- Use the optional Velocity measurement mode (Section 4.7)

 **Note:**

Load a Setup file corresponding to the connected probe prior to making the adjustments described in this chapter. Loading a Setup file after these adjustments are made will force certain settings back to the default value stored in the file.



 **Note:**

After making some or all of the adjustments described in this chapter, the modified instrument setup can be stored by creating a Custom Setup file. Your instrument will store up to 5 Custom Setup files, which are created (and erased) via the setup display. See Section 3.5 for step-by-step instructions to create a Custom Setup file.



4.1 Selecting the Displayed View

The measurement displayed by the instrument is modified by

Step 1: Press  multiple times to access the configuration menu

Step 2: Press  or  to select the VIEW MODE parameter

Step 3: Press  to activate this parameter

Step 4: Scroll through the available modes by pressing  or . Press  to select the displayed mode (described below).

Base model instruments offer four display modes. In addition, two more display modes are available depending on the installed options. Display modes include:

NORMAL (Thickness Only) – The thickness value appears as large digits in the center of the display. No live A-Scan is displayed but an A-Scan snapshot of the triggering echo can be accessed (Section 4.2).



MIN SCAN (Minimum Thickness Scan) – Allows the user to continuously evaluate material thickness (provided the probe remains coupled or is uncoupled only briefly) then, when the evaluation period is complete, the minimum material thickness is displayed. During the evaluation period, thickness is displayed along with the minimum and maximum observed thickness values (and the calculated difference between the

two). The display also includes a time-out bar, which begins to fill as soon as the probe is uncoupled. Recoupling the probe before the time-out period expires allows the user to continue with the same evaluation period. When the evaluation period is complete (after the probe is uncoupled and the time-out bar fills), the minimum thickness observed during the evaluation period is displayed. Its corresponding A-Scan can also be displayed by pressing . At this point the screen is frozen. Recouple the probe to reactivate the display screen (Section 4.3).

MAX SCAN (Maximum Thickness Scan) – Allows the user to continuously evaluate material thickness (provided the probe remains coupled or is uncoupled only briefly) then, when the evaluation period is complete, the maximum material thickness is displayed. During the evaluation period, thickness is displayed along with the minimum and maximum observed thickness values (and the calculated difference between the two). The display also includes a time-out bar, which begins to fill as soon as the probe is uncoupled. Recoupling the probe before the time-out period expires allows the user to continue with the same evaluation period. When the evaluation period is complete (after the probe is uncoupled and the time-out bar fills), the

maximum thickness observed during the evaluation period is displayed. Its corresponding A-Scan can also be displayed by pressing . At this point the screen is frozen. Recouple the probe to reactivate the display screen (Section 4.3).

 **Note:**

During the placement of a very sensitive probe on the part surface, excess couplant may cause erroneous results. To eliminate the effect of excessive couplant, couple the probe firmly to the part, then press  under the ASCAN function, then press  under HOME. This restarts the scanning session while the probe is properly in contact with the part.

DIFF / RR% (Differential / Rate-of-Reduction) – The currently measured and user-inputted nominal thickness appear along the top of the display while the difference between these two values (measured minus nominal values expressed in percentage and dimensional terms) appears in the middle of the display. Note that the displayed differences can have positive or negative values (Section 4.4).

THK + A-SCAN (Thickness and A-Scan, available only with A-Scan) – An A-Scan appears in the center

portion of the display and the thickness value is shown in the display's upper right-hand corner (Section 4.5).

VELOCITY (Material Velocity, available only with velocity option) – The material velocity value appears as large digits in the center of the display. This velocity calculation requires an accurate NOMINAL THICKNESS value which can be inputted by the user or by using the connected digital caliper. Note that no live A-Scan is displayed but an A-Scan snapshot of the triggering echo can be accessed (Section 4.6).

QUALITY (Quality View Mode, available only with Data

Recorder option) – The measurement bar graphic appears on the top of the screen together with the measurement location, name, minimum specified value, the target value and the upper specified value.

When the transducer is coupled to a part, the thickness value is displayed. The measurement bar graphic shows where the thickness value is in the range, with relation to the lower and upper specified limits.

4.2 Normal Measurement Mode (No Live A-Scan)

When NORMAL view mode is active, the display only contains a thickness reading. While no live A-Scan is available, an A-Scan Snapshot can be accessed at any time by pressing  directly below A-SCAN on the function bar (Figure 4-1).

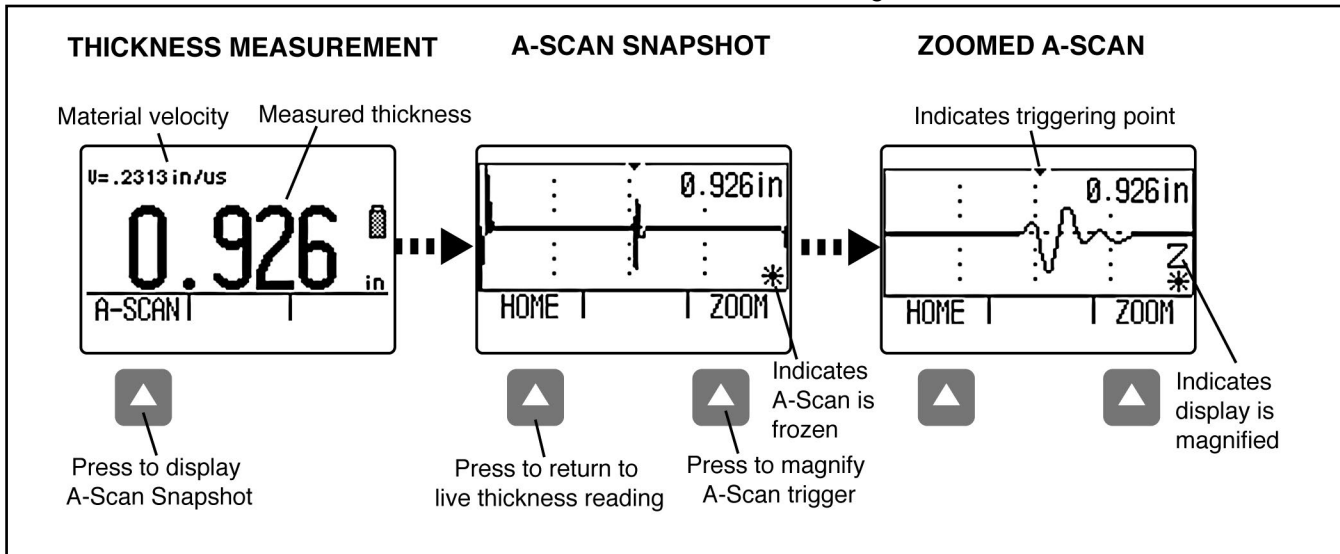

FIGURE 4-1—NORMAL view mode displays only the thickness reading. Selecting the A-SCAN function bar option allows you to view a Snapshot of the A-Scan echo that is represented by the thickness reading. This A-Scan is frozen. No live A-Scan echo is available in this view mode.

4.3 Min Scan and Max Scan Measurement Modes

These modes allow the user to continuously evaluate material thickness then, when the evaluation period

is complete, display the extreme (minimum or maximum) material thickness observed. During the evaluation period, thickness is displayed along with the minimum and maximum observed thickness values (Figure 4-2).

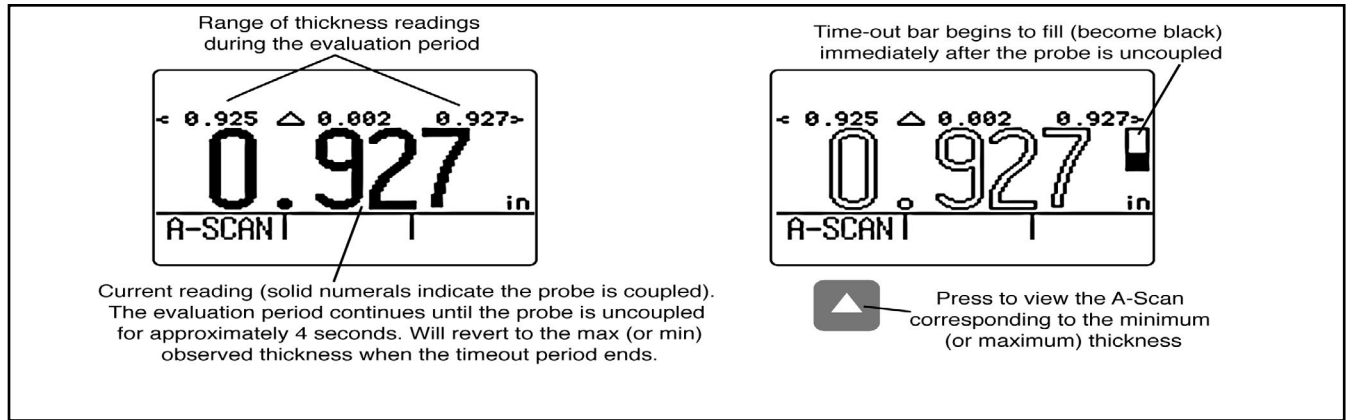

FIGURE 4-2—MIN SCAN and MAX SCAN allow observed measurements and display the maximum and minimum thickness encountered during the period. The time-out feature (represented by the bar shown here) allows a momentarily uncoupling during the evaluation period, and then recouple to continue the same period. In these modes the instrument will continue to collect and compare readings for as long as the probe remains coupled.

4.4 Quality View Mode

This view mode displays the current measurement location name, a measurement bar graphic of the thickness reading that shows the lower specified limit value, the nominal/target value and the upper specified limit. Below the measurement bar graphic is the numerical thickness measurement reading.

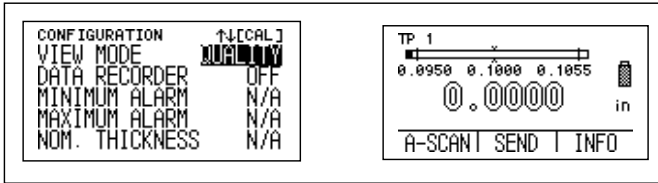

Fig 4.4.1: Selection of Quality View Mode and Quality View Mode Display

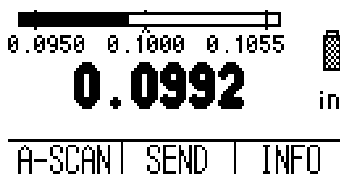
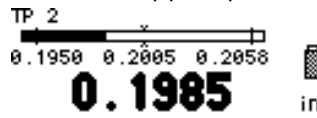

Fig 4.4.2 Numerical Value of Thickness is filled when probe is coupled to the location for measurement

When coupled to a part, the thickness value is displayed. The measurement bar graphic shows where the thickness value is in the range, in relation to the lower and upper specified limits.



The probe can be coupled to the next location. The thickness value and measurement bar are updated with the new thickness measurement value.



If the thickness is within the specification range the user can press SEND to capture the thickness value in the data recorder (when activated). Note: The location of the data recorder point is shown in the upper left of the display. After pressing SEND, the thickness value is saved.

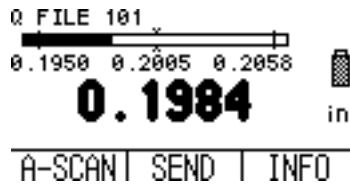

The arrow below INFO mode toggles the top line of the Quality View mode display to show the File Name or the Test Location Point Name.

Quality View Mode requires our optional data recorder option and a custom linear file to work. This Custom Linear File can be created using the Microsoft® Excel® Macro on your PC and downloaded into the CL5 using our optional Serial or USB cable.

This file can be prepared and downloaded into a SD card using our optional Ultramate or Ultramate Lite software on your PC.

4.5 Differential / Rate-of-Reduction Measurement Mode

This view mode displays the currently measured and user-inputted nominal thickness, along with the

difference between those two values (measured minus nominal) expressed in percentages and dimensional terms. Note that the displayed differences can have positive or negative values (Figure 4-3) **See Section 4.1 to select view mode and 3.2.3 to specify nominal thickness.**

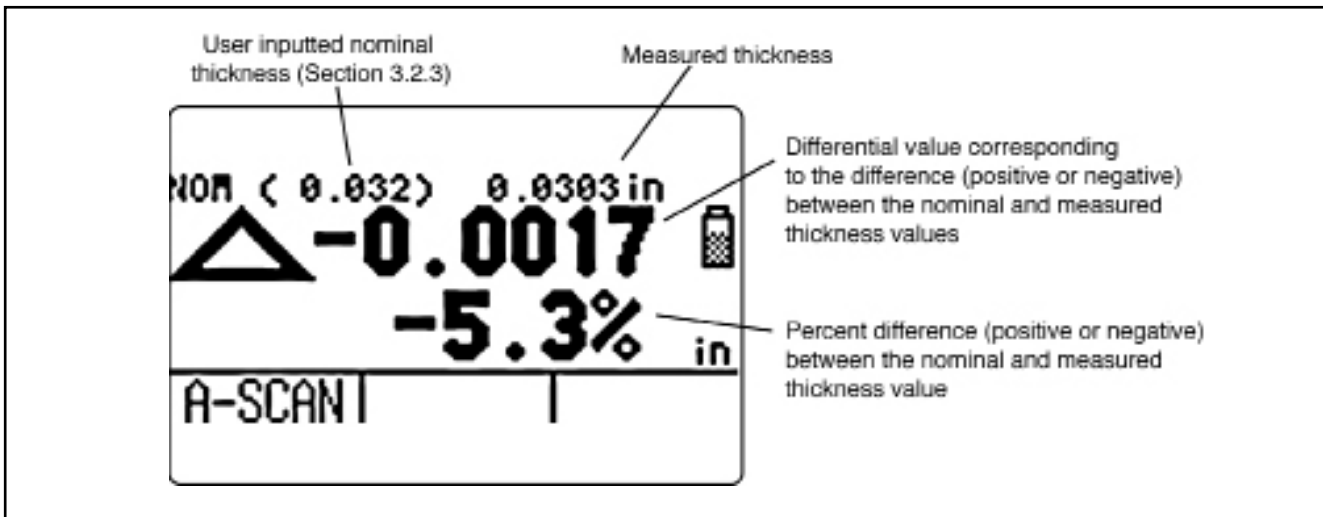

FIGURE 4-3—The DIFF / RR% view compares the live measurement with a user-inputted nominal material thickness. This comparison is then expressed as a differential measurement and a percentage of the nominal thickness.

4.6 Thickness + A-Scan Measurement Mode (Optional)

This optional view mode displays both a live A-Scan reading and corresponding thickness value. Selecting FIND moves the triggering echo to the center of the

display while FREEZE captures the live A-Scan. After the display is frozen, select ZOOM to magnify the triggering echo (Figure 4-4)

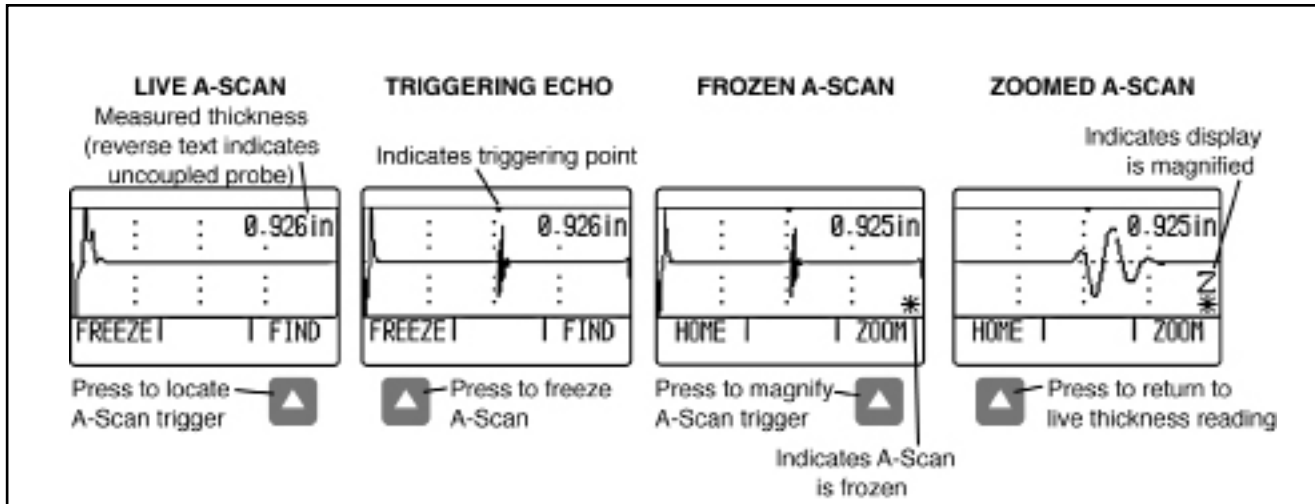

FIGURE 4-4—TK + A-Scan view mode displays, freezes, and magnifies a live A-Scan

4.7 Velocity Measurement Mode (Optional)

This *optional* view mode displays measured material velocity (see Section 4.1 to select mode). The material velocity calculation depends on the value inputted for the test material's nominal thickness. This nominal thickness value can be manually inputted (Section

3.2.3) or by using the digital micrometer supplied with all instruments that incorporate the Velocity option. (Figures 4-5 and 4-6). Note that when operating in VELOCITY view mode, material velocity values may be entered for MINIMUM and MAXIMUM ALARMS (Section 3.4)

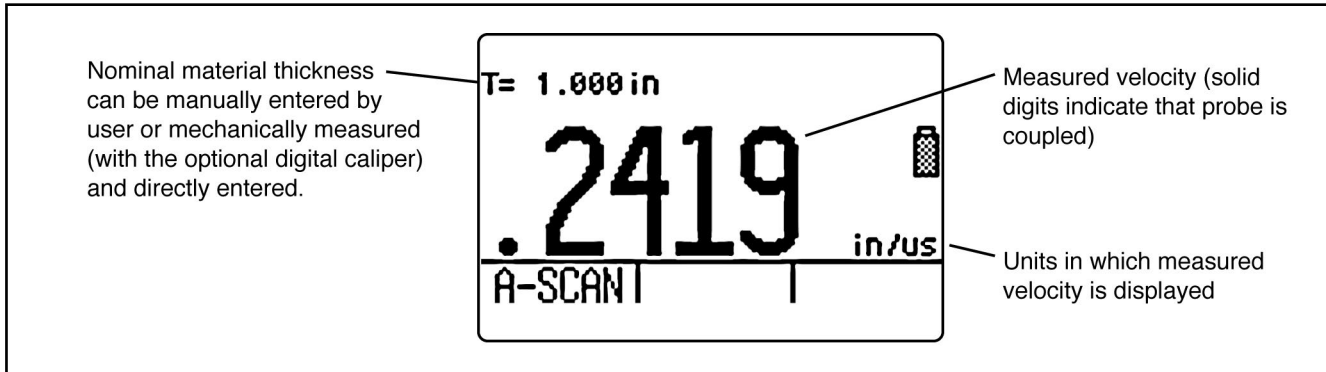

FIGURE 4-5—VELOCITY view mode allows measurement of acoustic velocity based on a user inputted (or manually measured) mechanical thickness.

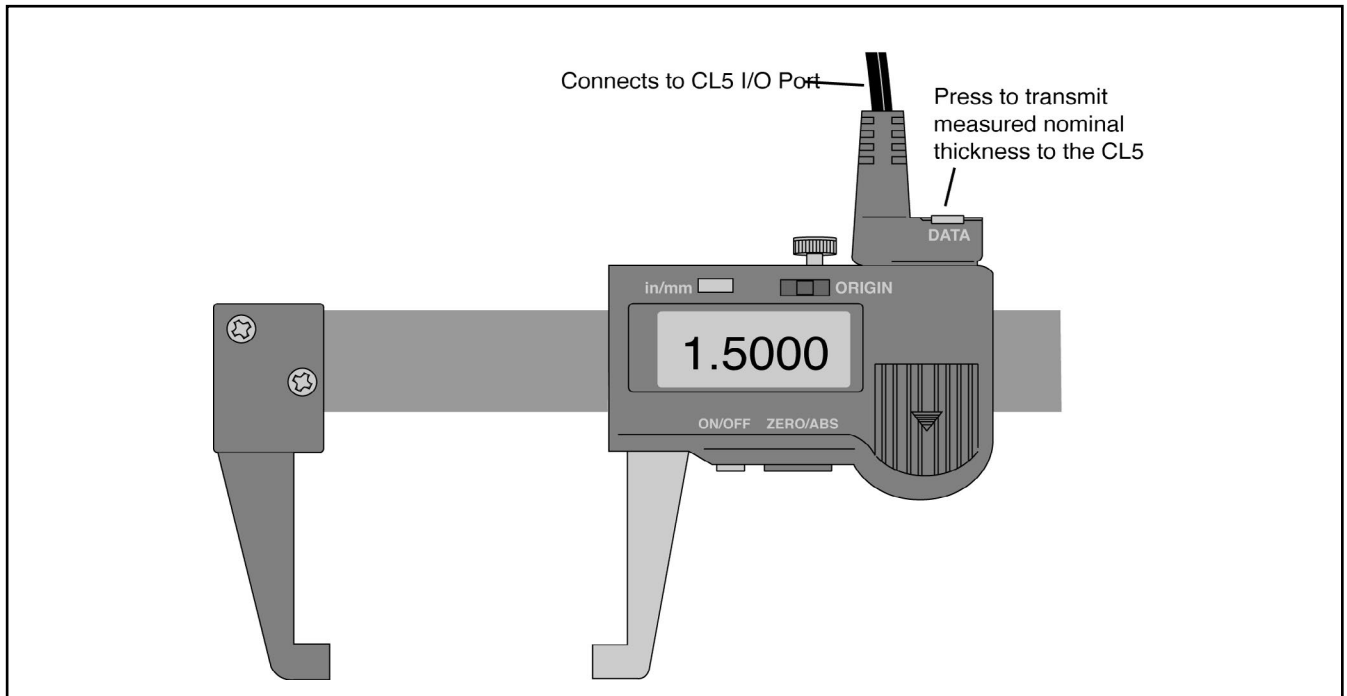

FIGURE 4-6—Direct input of nominal thickness in VELOCITY mode.

Typical Sound Velocities in Various Materials
(Longitudinal Wave)

	in/s x 10²	m/s			
			Rubber (Butyl)	730	1900
			Inconel	2200	5600
			Rubber (Vulc.)	900	2300
			Lead	850	2200
			Silver	1400	3600
Aluminum	2500	6300	Magnesium	2300	5800
Nylon	1000	2500	Steel	2300	5800
Brass	1700	4300	Manganese	1800	4600
Phenolic	560	1400	Tin	1300	3300
Cadmium	1100	2800	Molybdenum	2500	6300
Platinum	1600	4100	Titanium	2400	6100
Cast Iron	1800	4600	Neoprene	630	1600
Plexiglas	1100	2800	Tungsten	2100	5300
Copper	1800	4600	Monel	2100	5300
Polyethylene	700	1800	Zinc	1600	4100
Epoxy Resin	1100	2800	Nickel	2200	5600
Polystyrene	930	2400	Zircaloy 2	1900	4700
Glass (Crown)	2200	5600			
Polyurethane	700	1800			
Glass (Window)	2700	6800			
Porcelain	2200	5600			
Gold	1300	3300			

This information is provided for the convenience of the user. Waygate Technologies assumes no responsibility for inaccuracies.

Actual velocities depend on exact composition, temperature, and processing of each material.

Using the Optional Data Recorder **5**

 **Note:**

The instructions here apply only to instruments equipped with a Data Recorder including a SD card.

When installed and activated, the data recorder option allows users to create Data Recorder files, store thickness readings (and accompanying A-Scans when desired), and navigate through file contents. In this chapter you'll learn how to

- Create Data Recorder files (Section 5.1)
- Recall and erase Data Recorder files (Section 5.2)
- Store thickness readings in Data Recorder files (Section 5.3)
- Store A-Scans in Data Recorder files (Section 5.3.1)
- Navigate Data Recorder file locations to store or delete readings (Section 5.3.2)
- Print reports (Section 5.4)

5.1 Creating a New Data Recorder File

To create a new Data Recorder file, you need to specify a file name and top and bottom position. In most cases, however, you'll wish to enter additional information. Parameters that can be adjusted during the file-naming process include:

- The first (TOP) and last (BOTTOM) positions in the Data Recorder file (Figure 5-2 describes how these define the number of locations in the new file)
- The ADVANCE DIRECTION (described in Figure 5-2)
- NOTES related to the data file

Follow Steps 1 through 5 in Figure 5-1 to create a new Data Recorder file.

 **Note:**

Once created, the file name and size parameters can NOT be edited. Only the ADVANCE DIRECTION parameter and NOTES contents can be modified. To accomplish this, first select the file then activate and modify the parameter.

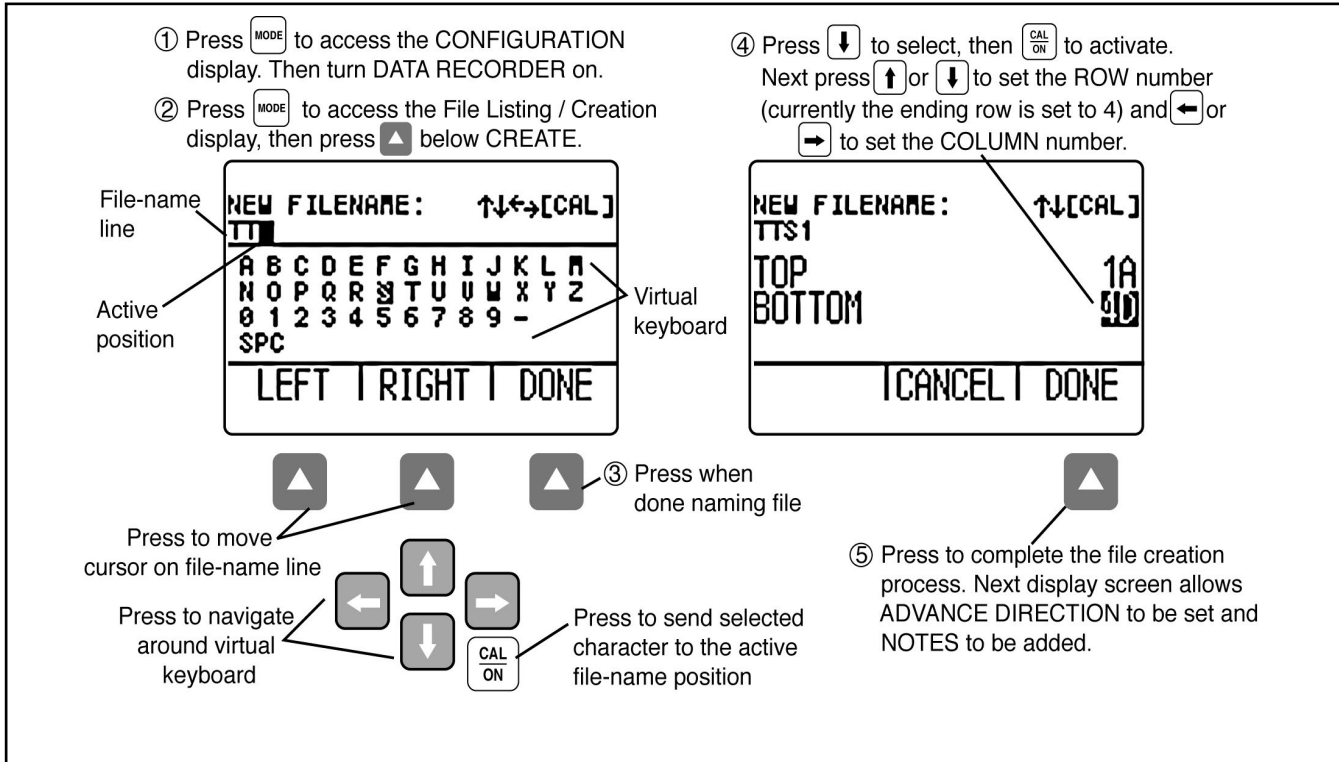

FIGURE 5-1—Creating a New Data Recorder File

5.2 Recalling and Erasing Stored Data Recorder Files

Stored files can be recalled or erased at any time. Once recalled, thickness measurements can be stored in empty file locations, existing measurements can be deleted and the advance direction can be changed. To recall a Data Recorder file:

Step 1: Press **MODE** to access the CONFIGURATION display, then set DATA RECORDER to ON.

Step 2: Press **MODE** again to launch the File Display mode

Step 3: Activate the file selection function by pressing **▲** below FILES. A file list will appear on the display.

Left Screen (File List):

TTS1XX			
	A	B	C
1	EMPTY	0.000	EMPTY
2	EMPTY	EMPTY	EMPTY
3	EMPTY	EMPTY	EMPTY

HOME | SEND | CLEAR

Annotations: Name of active file (TTS1XX), First column (A), First row (1).

Text: Active file location. When a thickness reading is stored here, the location below this will become the next active location as dictated by the ADVANCE DIRECTION setting below.

Text: Press **MODE** to display this screen (if DATA RECORDER is ON)

Right Screen (Configuration):

```

ACTIVE FILE      ↑[CAL]
TTS1XX
NUMBER OF ROWS   4
NUMBER OF COLUMNS 4
ADVANCE DIRECTION ↓
FILES | PRINT | CREATE
    
```

Annotations: Define the file size (4), Press **MODE** to display details on active file.

Text: Press **▲** to view and select from a list of all files

Text: Press **↓** to select, **MODE** to activate, then **↓** or **→** to change the advance direction. Currently indicates that the active file location will move from top to bottom of a column before moving to the next column.

FIGURE 5-2—Defining the Size and Advance Direction of a Data Recorder File

Step 4: Press arrows to select the stored file you wish to recall, and then press .

To erase a Data Recorder file:

Step 1: Press to launch the File Display mode

Step 2: If required, press arrow below FILES to obtain a list of stored files.

Step 3: Press arrows to select the stored file you wish to erase, and then press and hold below ERASE.

 **Note:**

Once erased, the Data Recorder file and any stored thickness measurements can not be retrieved.

5.3 Recording Thickness and Velocity Measurements in Data Recorder Files

The Data Recorder must be enabled (turned ON) via the CONFIGURATION display. Once the Data Recorder is turned on, the contents of the active Data Recorder file are displayed in the File Navigation Grid shown in Figure 5-2.

To store a thickness reading in the selected file position, press  below SEND. Remember that the units of the thickness value, and the number of decimal places to which the thickness is recorded, are determined by the UNITS and RESOLUTION settings as described in Section 3.2.

 **Note:**

Pressing  and holding below SEND for three seconds will cause the thickness and displayed live A-Scan to be stored in the selected position as described in Section 5.3.1.

Note:

Pressing  below SEND with the instrument connected to a PC that has the applicable software installed and running will result in the thickness reading being sent out the I/O port as described in Section 6.1.





5.3.1 Recording A-Scans in Data Recorder Files



A live A-Scan can be stored in that active position of the Data Recorder by pressing and holding  (for three seconds) below SEND.

Note:

A-Scan Attachments cannot be stored in Quality View Mode

5.3.2 Navigating Through Data Recorder Files

When the Data Recorder is turned on, the contents of the active Data Recorder file are displayed in the File Navigation Grid shown in Figure 5-2. Once the navigation grid is activated, , , , and  can be used to select any file position. Note that a heavier grid box appears around the selected file position. Once a file position is selected:

- The current thickness reading can be sent to an EMPTY file position
- A measurement value can be store by pressing below  SEND
- An already stored value can be deleted by pressing  below CLEAR

5.4 Printing a Report

 **Note:**

The following procedure explains how to print the contents of a stored Data Recorder file.

Once the instrument is configured for the connected PC (see Section 6.2), you can proceed with the report printing process. A printed report will include:

- A file header listing Data Recorder file name
- A description of the file's structure including number of rows, columns, and a listing of NOTES
- All thickness measurements stored in the Data Recorder file, along with an indication if the file has an A-Scan attached or resulted from a Minimum or Maximum thickness scanning session.
- Attached A-Scans are NOT printed as part of the report

Step 1: Press  to access the Data Recorder file display as shown in Figure 5-2.

Step 2: Follow the regular procedure to select the file to be printed.

Step 3: Press  below PRINT to launch the report printing process. All features listed above will be included in the printed report.

THIS PAGE LEFT INTENTIONALLY BLANK.

I/O Features **6**

Note:

The instructions in this chapter apply to all instruments.

The instrument can communicate with external devices in several ways. All of these communication methods rely on the instrument's I/O port. The following cables are available for connection to this RS-232 port (see Figure 3-1 for location):

- USB PC Cable
- Serial PC Cable
- Digital Caliper—Velocity Option
- Li Battery Pack's Charging cable

The instrument determines if the cable is connected to a device provided the device is not "off line" or "busy".

Individual thickness readings and A-Scans can be transmitted to an attached device. With the use of remote codes, a PC can control the instrument.

In this chapter you will find:

- The byte structure used when thickness readings are transmitted through the I/O port (Section 6.1)
- Remote commands (Section 6.2)

6.1 Transmitting Data to an External Device



When  below SEND is pressed to transmit a thickness or velocity value through the I/O port, data will be transmitted at 8 data bits, 1 stop bit, no parity, and at the user-specified baud rate. The transmitted data will be in a 13-byte message format, structured as shown in Table 6-1. Note that data can be transmitted (and SEND appears) only when the PC cable is connected to a device that can receive data.



Table 6-1	
Format of Transmitted Thickness Measurements	
Byte 1	"+" or "-" for displayed differential thickness values "?" for displayed high resolution metric velocity values " " (space) for all other displayed values
Byte 2,3,4,5,6	Display value (4 digits and decimal point) .0000 0.000 00.00 000.0 0000.
Byte 7	" " (space)
Byte 8,9,10,11	"IN " for displayed inch thickness values "MM " for displayed metric thickness values
Byte 12	Carriage Return (ASCII 13)

6.2 Setting Communication Speed (Baud Rate) and Connecting to a PC

Using the proper cable, the instrument's I/O port can be connected to a PC. Before connecting to a PC do the following:

Step 1: Press  to display the CONFIGURATION menu

Step 2: Select the COMM (communication) control

Step 3: Press  to activate the control, then  or  to adjust the selected baud rate to match that of the connected device. Data transfer will not occur if the selected baud rate does not match the device.

Step 4: Press  when the desired value is selected.

6.3 Remote Commands

The CL 5 can receive coded instructions from a personal computer or terminal connected to the RS-232 I/O port. Queries, key presses and adjusting

instrument settings can be done remotely by using a user written program or a commercially available serial communications program such as Windows™ HyperTerminal. After starting and configuring the program, commands are inputted using the computer keyboard.

Two types of command structures are possible:

- To request the status or value of a function the following sequence is used:
- To execute a keypad operation or adjust a setting the following sequence is used:

<ESC><COMMAND><RETURN>

<ESC><COMMAND><SPACE><VALUE><RETURN>

Examples:

<ESC><ID><RETURN>

The CL 5 will now return the model of the instrument.

<ESC><7K><SPACE><8><RETURN>

The CL 5 will respond as if the user has pressed the mode button.

Remote Control Codes:

The following is a partial listing of remote commands. Additional remote commands are available upon request.

Strings inside [] are values / parameters

Code	Query	Parameter	Range	Resolution	Function
ID*	Yes (not req.)				Identification: INSTRUMENT returns "CL5".
DP*	Yes (not req.)				Directory of Parameter Sets: INSTRUMENT will return a list of parameter sets (custom setups) in the same format as the file directory structure: 0001 XXXXXXXXXXXXXXXXXXXX 0002 XXXXXXXXXXXXXXXXXXXX 0003 XXXXXXXXXXXXXXXXXXXX 0004 XXXXXXXXXXXXXXXXXXXX
DR*	Yes (not req.)				Directory: INSTRUMENT will return a list of data recorder files with file type information (file name field indicated by X's is 24 characters): (only supported when Data Recorder option is enabled.) 0001 XXXXXXXXXXXXXXXXXXXX GRID 0002 XXXXXXXXXXXXXXXXXXXX CLIIN

FX (n)	NO	file num- ber on dir list	1 to Number of files	1	INSTRUMENT will transmit the file indicated by (n). (n) should be the file number as displayed on the directory list. (only supported when Data Recorder option is enabled.)
<i>(Continued)</i>					

Code	Query	Parameter	Range	Resolution	Function
PD [n]	NO	Parameter set number	0 to 11 (0 to 12 if velocity option is enabled)		Parameter Set Download: INSTRUMENT will go into parameter set download mode sending the requested parameter set. [n] indicates the parameter set number that is requested. 0 sends the presently active instrument parameters.
AP [str]	NO	Setup Name			Loads the setup indicated by the parameter string name specified.
AF [n]	YES	file number on dir list	1 to number of files	1	Active File: Set / Query the active data recorder file.

7K [n]	NO	key press code		1	<p>Key Press: [n] = value indicated what key press to execute.</p> <p>KCODE_F1 1 KCODE_F2 2 KCODE_F3 3</p> <p>KCODE_UP_ARROW 4 KCODE_DOWN_ARROW 5 KCODE_LEFT_ARROW 6 KCODE_RIGHT_ARROW 7</p> <p>KCODE_MODE 8 KCODE_ON_CAL 9</p>
7H	NO				HOME: Sets instrument to TG measurement view mode.
<i>(Continued)</i>					

Code	Query	Parameter	Range	Resolution	Function
7R	NO				Soft parameter reset. Resets the following parameters to their defaults: View Mode: Thickness Radix: PERIOD Backlight: OFF Language: English Batteries: Alkaline (unless Li battery is detected) Power Down: Auto Units: INCH Resolution: X.XXX Lock Outs: OFF (all lockout parameters) Nominal Thickness: 0.000 Min / Max Alarms: 0.000 (OFF) Baudrate (not-affected)
8J	YES(not req)				Query for Operating System version number
8K	YES(not req)				Query for Instrument Serial Number

MS	Yes				Query for the present instrument thickness, velocity, couple status
8Y	NO	LCD Memory Dump			Will dump data containing the bitmap of the LCD display memory in one of several formats. This is the binary dump. This dumps the video memory byte for byte.
<i>(Continued)</i>					

Code	Query	Parameter	Range	Resolution	Function
MS	YES				<p>Query for the present instrument thickness, velocity, couple status:</p> <p>Output Format: (comma delimited fields) Thickness , Velocity , couple status</p> <p>Thickness will always be a whole number in .001 mm resolution. Velocity will be in 0.1 m/s. Couple flag will be "C" for coupled, "U" for uncoupled</p>

Specifications 7

This chapter lists the features and specifications of your CL 5 including:

- Instrument Specifications (Section 7.1)
- Features of the Optional A-Scan (Section 7.2)
- Features of the Velocity Measurement Option (Section 7.3)
- Features of the Optional Data Recorder (Section 7.4)
- Probe Specifications (Section 7.5)

7.1 Instrument Specifications

Operating Principle:	Ultrasonic, pulse echo measurement method
Measuring Range:	0.006 to 20.00 inch depending on probe and material 0.13 to 500 mm
Measuring Resolution:	inch 0.001 default (selectable 0.0001, 0.001, 0.01 inch) mm 0.01 default (selectable 0.001, 0.01, 0.1 mm)
Material Velocity Range:	0.03937 to 0.78736 in/ μ s 1000 to 19999 m/s
Material Velocity Resolution:	0.00001 in/ μ s 0.1 m/s

Units:	Inch or millimeter
Calibration:	Enter velocity or thickness Contact: One point or Two point calibration Delay: One point
Pulser:	
Excitation Pulse:	Spike Pulser
Voltage:	100 V into 50 ohm load, using 20 MHz Scope
Receiver	
Bandwidth:	1.0 to 16 MHz @ -6 dB
Gain:	Automatic Gain Control
Display Type:	High Resolution: Graphical LCD 64 × 128 Pixels, 2.25" × 2.56" (40 × 57 mm) with backlight and adjustable contrast.
Update Rate:	4 Hz or 8 Hz (User Selectable)
Thickness Value Display:	5 digit 0.75" (19 mm) high NORMAL MODE 5 digit 0.25" (6 mm) high with display of A-SCAN)

Display of Last Reading:	Solid filled or hollow digits indicate coupled or uncoupled condition.
Setups:	6 Standard Setups for Contact and Delay probes 5 Custom Setups with up to 16 character alphanumeric name
Alarm Settings:	Minimum and Maximum Alarms Range of 0.005–20 in. (0.1–508 mm) Red LED illuminates and < or > displayed when alarms are enabled and violated.
Power Requirements:	Standard Li Battery Pack with on-board charger. Batteries 3 each, "AA" size Alkaline, NiCad or NiMH
Battery Life/Operating Time:	Approximately 24 hours
Instrument Shut-Off:	Selectable ALWAYS ON or AUTO OFF after 3 minutes of inactivity
Language:	Selectable English, German, French, Spanish, Italian, and Russian
Baud Rate:	Selectable 115200, 57600, 9600, 1200

I/O Connectors

Transducer: 00 Lemo (coax)
RS-232, Battery Charger: Micro-D9 (Female),
Charger 100-240 V, 50-60 Hz

Temperature

Operating: +10°F to +140°F (-10°C to +60°C)
Storage: -10°F to +160°F (-20°C to +70°C)

Weight: 0.92 lbs. (420 g) including batteries

Size: 7.1" H x 3.7" W x 1.8" D (180 mm x 94 mm x 46 mm)

Instrument specifications subject to change without prior notice.

7.2 A-Scan Option Parameter Adjustments

Display View Thickness + A-Scan

Instrument specifications subject to change without prior notice.

7.3 Velocity Measurement Option Features

Display View VELOCITY Measurement

7.4 Data Recorder Option Features

Capacity:	120 files each containing 10,000 readings with or without A-Scan attachments (May vary based on size of SD card used.)
File Structures	Grid created from instrument keypad and Custom Linear created with UltraMATE
File Naming:	Up to 24 character alphanumeric name
Optional Software:	UltraMATE and UltraMATE Lite

Instrument specifications subject to change without prior notice.

7.5 CL 5 Probe/Transducer Specifications

Model	Probe Type	Nominal Freq.	Contact Diameter	Measuring Range
A-2 DFR & CLF4	Standard Delay Line	15 MHz	0.30 in. 7.6 mm	0.007 to 1.0 in. 0.18 to 25.4 mm Steel

Model	Probe Type	Nominal Freq.	Contact Diameter	Measuring Range
Alpha 2F & CLF5	Fingertip Contact	10 MHz	0.38 in. 9.5 mm	0.060 to 10.0 in. 1.52 to 254 mm Steel
Alpha DFR-P	Plastics, Delay Line	22 MHz	0.30 in. 7.6 mm	0.005 to 0.15 in. 0.13 to 3.8 mm Plastic
Mini-DFR	Thin Range Delay Line	20 MHz	0.19 in. 4.8 mm	0.006 to 0.200 in. 0.16 to 5.1 mm Steel
K-Pen	Pencil Probe	15 MHz	0.065 or 0.090 in. 1.7 or 2.3 mm	0.010 to 0.175 in. 0.254 to 4.4 mm Steel
CA211A	Standard Contact	5 MHz	0.75 in. 19.1 mm	0.060 to 20.0 in. 1.52 to 508 mm Steel

Note: Other Probe Models Available Upon Request

THIS PAGE WAS INTENTIONALLY LEFT BLANK.

Maintenance 8

Care of the Instrument

Clean the instrument housing and display using a soft cloth lightly dampened with water or a mild window-cleaning product. Never use harsh solvents as they could cause the plastic to become brittle or damaged.

Care of Delay Line Probes

Replace delays showing signs of excessive wear or those embedded with metal turnings. Delays in good condition should periodically have the couplant between the probe face and delay refreshed as follows:

- Remove the delay by unthreading the knurled ring
- Wipe clean the mating surfaces of the delay and transducer face
- Apply a fresh drop of lightweight oil (recommend XD-740 couplant) and replace the delay line

Proper Cable Handling

- Avoid twisting or knotting of the cable
- Grasp the cable only by the connectors when connecting or disconnecting from the instrument

Batteries

Periodically inspect the batteries for signs of leakage or corrosion. If either occurs, remove and replace ALL the batteries. Take care to properly dispose of the defective batteries.

Appendix 9

This section contains supplementary information including instructions on:

- Resetting the Instrument's Operating Software
- Upgrading the Instrument's Software
- EMC Documentation
- Manufacturing and Service Center Locations

9.1 Resetting the Operating Software

WARNING: The following procedure deletes all Custom Setup files stored in the instrument. Any files you wish to retain should be downloaded using the UltraMATE PC software before resetting the operating software. Data recorder files (if so equipped) stored on the installed SD card will not be deleted.

To reset the instrument's operating software:

Step 1: Turn off the instrument.

Step 2: Press and hold down  then press

and hold down . Continue to press both keys for approximately three (3) seconds until the power-on sequence is initiated.

Step 3: A successful reset is acknowledged when the RESET COMPLETE message briefly appears in the display screen's bottom center.

9.2 Upgrading the Operating Software

The CL 5 operating software can be upgraded using an internet connection and an upgrade utility program. Each instrument is shipped with a USB stick containing the CL 5 Upgrade Utility Program.

Step 1: Install the Upgrade Utility Program on your Internet connected PC.

Step 2: Run the program by clicking on the program icon, located on your Program Menu. (Click the START and then RUN buttons, select PROGRAMS, and select CL 5 Upgrade Utility.)

Step 3: Select the Download New File button.

The program will connect to the Waygate Technologies, FTP site (you may need to be connected to the Internet prior to this operation). The program checks the version you have on your machine against the version that is on the FTP site. If the version on the FTP site is newer, it will download the CL 5 operation code. If they are the same, it will not download the program, but exit the download routine.

Step 4: Turn off the CL 5 and connect it to the PC.

Step 5: Click on the Upgrade The Instrument button.

Step 6: WHEN PROMPTED, press and hold the  and for 3 seconds. The CL 5 will go into the re-programming mode. When finished, the CL 5 will automatically shut off.

Step 7: Reset the operating software to clean out the instrument's memory (**WARNING:** All stored Custom Setup Files will be lost!!! However, stored Data Recorder files will not be affected).

Information available on the Waygate Technologies, website: waygate-tech.com

- Up to date information on operating software
- Latest upgrade utility program
- Specifications
- New features
- Literature
- And much more!

9.3 Manufacturer/Service Addresses

The CL 5 is manufactured by:

Das CL 5 wird hergestellt von:

Baker Hughes Digital Solutions GmbH

Robert-Bosch-Straße 3
50354 Hürth
Deutschland

T +49 (0) 22 33 601 111
F +49 (0) 22 33 601 402

The CL 5 is manufactured according to state-of-the-art methods using high-quality components. In-process testing and a quality management system certified to ISO 9001 ensure optimum quality of instrument conformance. Nevertheless should you experience a problem or require technical assistance, visit the product service page accessible from waygate-tech.com to locate your local WAYgate Technologies representative, or contact one of the following addresses:

Germany

Baker Hughes, GmbH
Service-Center
Robert-Bosch-Straße 3
D-50354 Huerth

or:

Postfach 1363
D-50330 Huerth

Telephone +49 (0) 22 33 - 601 111
Fax +49 (0) 22 33 - 601 402

France

Waygate Technologies Scs
68, Chemin des Ormeaux
69760 Limonest
France

Telephone +33 4 72 - 17 92 20
Fax +33 4 78 - 47 56 98

USA

Waygate Technologies, LP
201 Beltway Green
Pasadena, TX 77503

Telephone +1 832-325-4368

Index **10**

A

A-Scan Upgrade Option1-15
ADVANCE Direction 5-59
alarm 3-41
Auto Power Down..... 3-34

B

Backlight 3-34
backlight 2-27
batteries 1-12
battery indicator1-14
battery type 2-28
battery types1-13
BOTTOM 5-59

C

Calibration 3-38
CLEAR 5-63
COMM..... 6-69
Configuration Display..... 2-27
Contrast 3-35
contrast 2-27
Couplants..... 0-8
Custom Setup file 3-39

Custom Setups.....3-32

D

Data Recorder file 5-59
Data Recorder Upgrade Option..... 1-17
Decimal 3-35
Differential / Rate-of-Reduction
Measurement Mode 4-53
Display Screen 2-22
Displayed View..... 4-46
Doubling 0-8

E

EMPTY 5-63
erase a Data Recorder file 5-61
Erasing Custom Setup Files 3-39

F

FILE DISPLAY MODE 2-25
File Navigation Grid..... 5-60
FILES 5-59
FIND 4-54
FREEZE 4-54

G		
Gain	3-36	
I		
I/O port	6-67	
K		
Key functions	2-21	
Keypad	2-21	
L		
Language	3-35	
Lithium (Li) battery	1-13	
lockout	3-43	
M		
MAX ALARM TK	3-41	
MAX SCAN	4-50	
Maximum and Minimum Alarms	3-38	
MEASUREMENT DISPLAY MODE	2-25	
MIN ALARM TK	3-41	
MIN SCAN	4-50	
N		
Nominal Thickness	3-36	
NORMAL view	4-49	
NOTES	5-59	
O		
operating software	9-87	
Options	1-16	
P		
POWER DOWN	2-28	
Powering On	1-14	
Printing a Report	5-64	
Probe	3-31, 7-81	
R		
Radix	3-35	
Remote Commands	6-69	
Report	5-64	
reset the instrument	9-87	
Resolution	3-35	

Index

S

Safety	0-9
SEND	5-63
Serial PC Cable	6-67
Service	0-10, 9-90
SETUP DISPLAY MODE	2-26
Setup File	3-31
Software	9-87
Specifications.....	7-77

T

Temperature	0-8
Thickness+A-Scan Measurement Mode	4-54
thickness alarm	3-41
TOP	5-59
Training	0-6
Transducer Selection	0-6
Transducer Specifications	7-81
transmitted data	6-67

U

Units	3-35
Update Rate	3-36
upgrade utility program	9-87

V

Velocity Measurement Mode	4-55
VIEW MODE	4-46

W

Warnings.....	0-6
---------------	-----

Z

zeroing	3-37
ZOOM.....	4-54



Waygate

Technologies is an active participant in Europe's Waste Electrical and Electronic Equipment (WEEE) take-back initiative, directive 2002/96/EC.

The equipment you purchased required the extraction and use of natural resources for its production. It may contain hazardous substances that could impact health and the environment. In order to avoid the dissemination of those substances in our environment and to diminish the pressure on the natural resources, we encourage you to use the appropriate take-back systems. If you need more information on the collection, reuse and recycling systems, please contact your local or regional waste administration.

RemoteService@bakerhughes.com

waygate-tech.com

ISO 9001
REGISTERED COMPANY

© 2021 Baker Hughes

All rights reserved. Specifications subject to change without notice.

Baker Hughes 

bakerhughes.com