

INTRODUCTION

The Blancett Active Sensor is a state-of-the-art, digital signal processing device designed to provide exceptional accuracy at a very affordable price. Designed for use with turbine meters, the sensor measures and calculates the flow rate to produce an analog current or voltage output representative of the meter's flow rate.

The Active Sensor is offered in two versions with a wide range of compatible turbine flow sensors:

- The F-to-I converter provides a 4...20 mA output in a two wire, loop powered configuration.
- The F-to-V converter offers a 0...5V DC output for those applications where a Voltage output is preferred.
- Can be used with Blancett 1100, QuikSert, and FloClean series turbine flow sensors.

OPERATING PRINCIPLE

Fluid entering the meter passes through the inlet flow straightener which reduces its turbulent flow pattern and improves the fluid's velocity profile. Fluid then passes through the turbine, causing it to rotate at a speed proportional to the fluid velocity. As each turbine blade passes through the magnetic field at the base of the magnetic pickup, an AC Voltage pulse is generated in the pickup coil (see *Figure 1*). These pulses are converted to either a current or Voltage that is proportional to the volumetric flow through the meter.

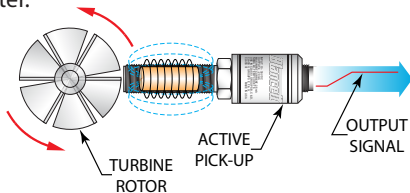

Figure 1: Schematic illustration of electric signal generated by rotor movement

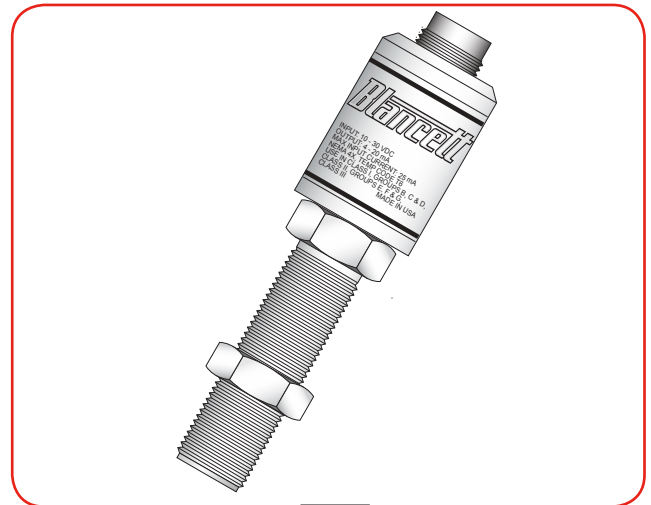

Figure 2: Typical turbine flow meter with active sensor installed

SPECIFICATIONS

Power	
Frequency to Current (F-to-I)	Loop powered, 6 V insertion loss maximum 10...30V DC supply range
Frequency to Voltage (F-to-V)	10...30V DC supply range (3-wire output)
Inputs	
Frequency	0...3500 Hz
Trigger Sensitivity	30 mV _{p-p}
Frequency Measurement Accuracy	±1%
Analog Output	
Resolution	1:4000
Temperature Drift	50 ppm / °C (max)
Linearization	
	10 point using IFC programming utility (PN B220-953)
Threads	
	5/8-18 UNF
Environmental	
Ambient Temperature	-22...158° F (-30...70° C)
Humidity	0...90% non-condensing

CONNECTION

The 4...20 mA output can drive auxiliary devices (resistive loads) such as displays, recorders and computers, provided the voltage supplied by the power source is adequate. Devices must be wired in series with the F-to-I converter and power supply. The voltage drop across the load(s) and the 6V DC minimum needed to drive the F-to-I converter determine the minimum voltage required from the power supply.

The F-to-I converter acts as a current controlling device. Thus, the current output remains the same even if the power supply voltage fluctuates or the load resistance changes. The current varies only with respect to the flow rate from the turbine flow meter, as long as the voltage drop across the F-to-I converter is at least 6V DC.

The load(s) in the circuit generally have some electrical resistance, 100 Ohms for this example. The 4...20 mA loop current produces a Voltage drop across each load. The maximum Voltage drop across a load(s) exists when the loop current is 20 mA. The power supply must provide enough Voltage for the load(s) plus the 6V DC minimum insertion loss of the F-to-I converter.

Figure 5 shows a graphical representation of the allowable loads for a given power supply voltage.

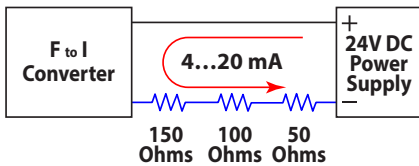

Total load resistance = 300 Ohms
 Total current loop current = 20 mA
 $300 \text{ Ohms} \times 20 \text{ mA} = 6000 \text{ mV} = 6 \text{ Volts}$
 The total voltage drop across the load is 6 Volts.

Figure 3: Example 1—Sufficient power supply Voltage

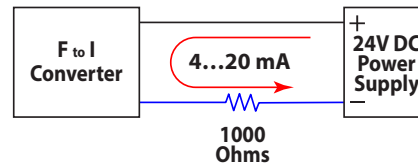

Total load resistance = 1000 Ohms
 Total current loop current = 20 mA
 $1000 \text{ Ohms} \times 20 \text{ mA} = 20,000 \text{ mV} = 20 \text{ Volts}$
 The total voltage drop across the load is 20 Volts

Figure 4: Example 2—Insufficient power supply Voltage

Example 1 shows an installation where the available voltage from the power supply is sufficient to accommodate a 6 Volt drop. Subtract 6 Volts from the 24 Volt source to determine that 18 Volts are available to power the F-to-I converter. The 18 Volts is within the specified 10...30 Volt range and is sufficient to power the F-to-I converter.

Example 2 shows an installation where the available voltage from the power supply is not sufficient to accommodate a 20 Volt drop. Subtract 20 Volts from the 24 Volt source to determine that 4 Volts is available to power the F-to-I converter. The 4 Volts is below the specified 10...30 Volt range so is not adequate to power the F-to-I converter. If for example, the power supply voltage was 30 Volts instead of 24 Volts, the Voltage available to power the F-to-I converter would be 10 Volts and within the specified range.

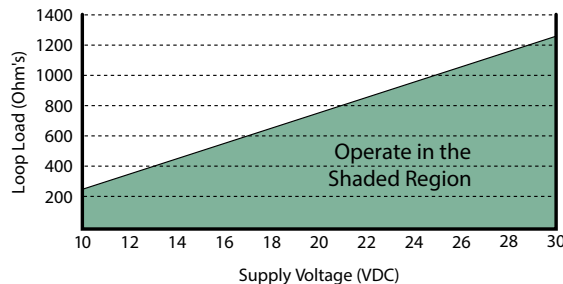

Figure 5: Allowable loop resistance chart

OPERATION

Once power is applied, the converter outputs an analog value representative of the measured frequency from the turbine meter. See Figure 6 or Figure 7—which ever corresponds to the converter that you have selected for your application.

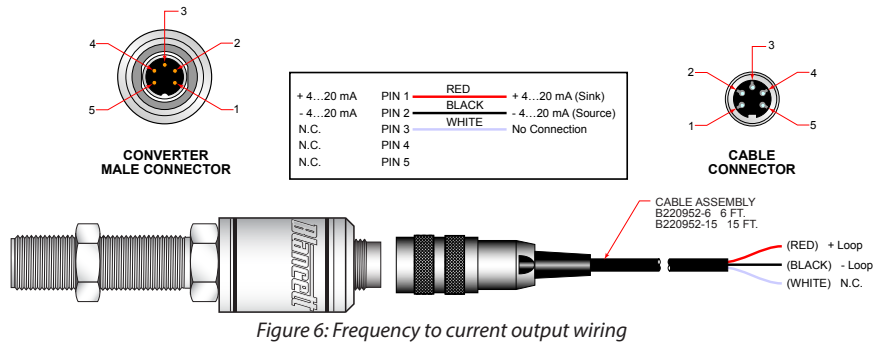

Figure 6: Frequency to current output wiring

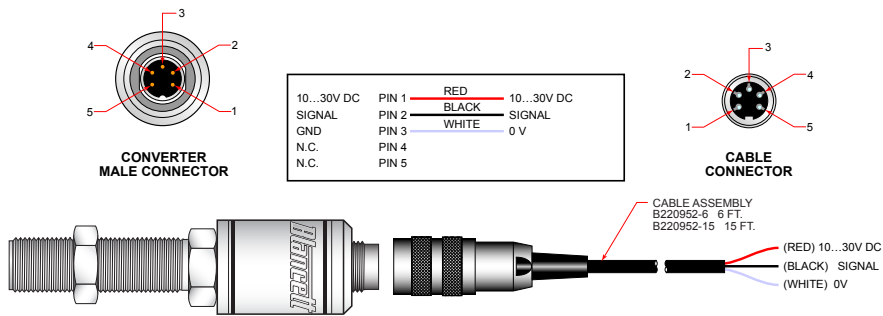

Figure 7: Frequency to Voltage output wiring

NOTE: If your active sensor was purchased with a Blancett turbine meter, the two components ship from the factory calibrated as a set. If the active sensor is a replacement, the turbine’s K factor has changed, or the sensor is being used with some other pulse-generating device, programming is necessary.

PROGRAMMING

NOTE: For complete instructions on programming the Blancett intelligent converters see the IFC Programming Manual.

Requirements

- Sensor/Transducer IFC programming kit PN B220-953
- RS232 cable (connects programming cable to PC)
- IBM Compatible PC running Windows® 95 or newer operating system
- DC Power Supply

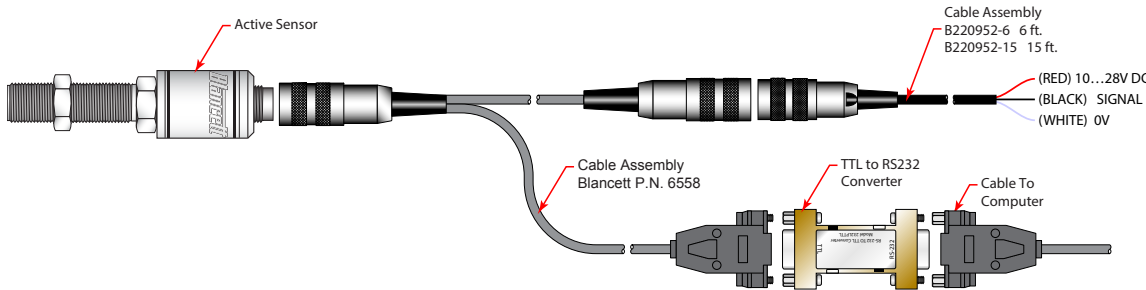

Figure 8: 6558 programming cable connections

NOTE: The TTL-to-RS232 converter may be as shown in Figure 8 or it may be a black molded model.

1. Install the programming software.
 2. Attach the programming cable (*Figure 8*) to the active sensor through a Com port on your PC.
- NOTE:** For computers without an RS232 serial port, you may need a USB-to-serial converter.
3. Using a DC power supply, apply 10...30V DC to the active sensor.
 4. Start the IFC programming software. The first screen should appear as in *Figure 9*.

NOTE: If communication fails, check cabling and/or Com port address and try again.

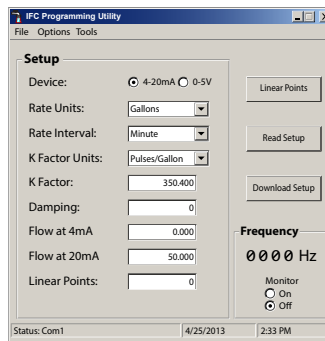

Figure 9: IFC programming screen

5. Press **Read Setup** to view how the converter is currently programmed.
6. Make any necessary changes and press **Download Setup**.

MAINTENANCE

1. Make frequent inspections. Create a schedule for maintenance checks based on the environment and frequency of use.
2. Perform visual, electrical and mechanical checks on all components on a regular basis.
 - a. Visually check for undue heating evidenced by discoloration of wires or other components, damaged or worn parts, or leakage evidenced by water or corrosion in the interior.
 - b. Electrically check to make sure that all connections are clean and tight, and that the device is operating correctly.

DIMENSIONS

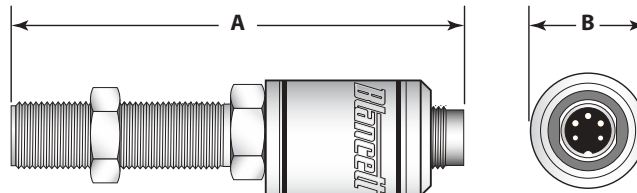

Figure 10: Active sensor dimensions

A	B
4.28 in. (109 mm)	1.15 in. (29 mm)

TROUBLESHOOTING GUIDE

Trouble	Remedy
No Current Output	Check polarity of the current loop connections for proper orientation. Make sure receiving device is configured to provide loop current.
Analog output reads a constant reading	Make sure there is flow in the system. Verify that the rotor inside the turbine meter turns freely.
Analog output is not stable	External noise is being picked up by the sensor. Keep all AC wires separate from DC wires. Check for radio antenna in close proximity. This usually indicates a weak signal.

Control. Manage. Optimize.

Blancett is a registered trademark of Badger Meter, Inc. Other trademarks appearing in this document are the property of their respective entities. Due to continuous research, product improvements and enhancements, Badger Meter reserves the right to change product or system specifications without notice, except to the extent an outstanding contractual obligation exists. © 2014 Badger Meter, Inc. All rights reserved.

www.badgermeter.com

The Americas | Badger Meter | 4545 West Brown Deer Rd | PO Box 245036 | Milwaukee, WI 53224-9536 | 800-876-3837 | 414-355-0400
 México | Badger Meter de las Americas, S.A. de C.V. | Pedro Luis Ogazón N°32 | Esq. Angelina N°24 | Colonia Guadalupe Inn | CP 01050 | México, DF | México | +52-55-5662-0882
 Europe, Middle East and Africa | Badger Meter Europa GmbH | Nurtinger Str 76 | 72639 Neuffen | Germany | +49-7025-9208-0
 Europe, Middle East Branch Office | Badger Meter Europe | PO Box 341442 | Dubai Silicon Oasis, Head Quarter Building, Wing C, Office #C209 | Dubai / UAE | +971-4-371 2503
 Czech Republic | Badger Meter Czech Republic s.r.o. | Mařikova 2082/26 | 621 00 Brno, Czech Republic | +420-5-41420411
 Slovakia | Badger Meter Slovakia s.r.o. | Racianska 109/B | 831 02 Bratislava, Slovakia | +421-2-44 63 83 01
 Asia Pacific | Badger Meter | 80 Marine Parade Rd | 21-06 Parkway Parade | Singapore 449269 | +65-63464836
 China | Badger Meter | 7-1202 | 99 Hangzhong Road | Minhang District | Shanghai | China 201101 | +86-21-5763 5412

Legacy Document Number: 02-SEN-UM-00102-EN