

**Model HTT**

**Hot Tap Tool for Badger®  
Series 225/226 Flow Sensors**

**Installation &  
Operation Manual**

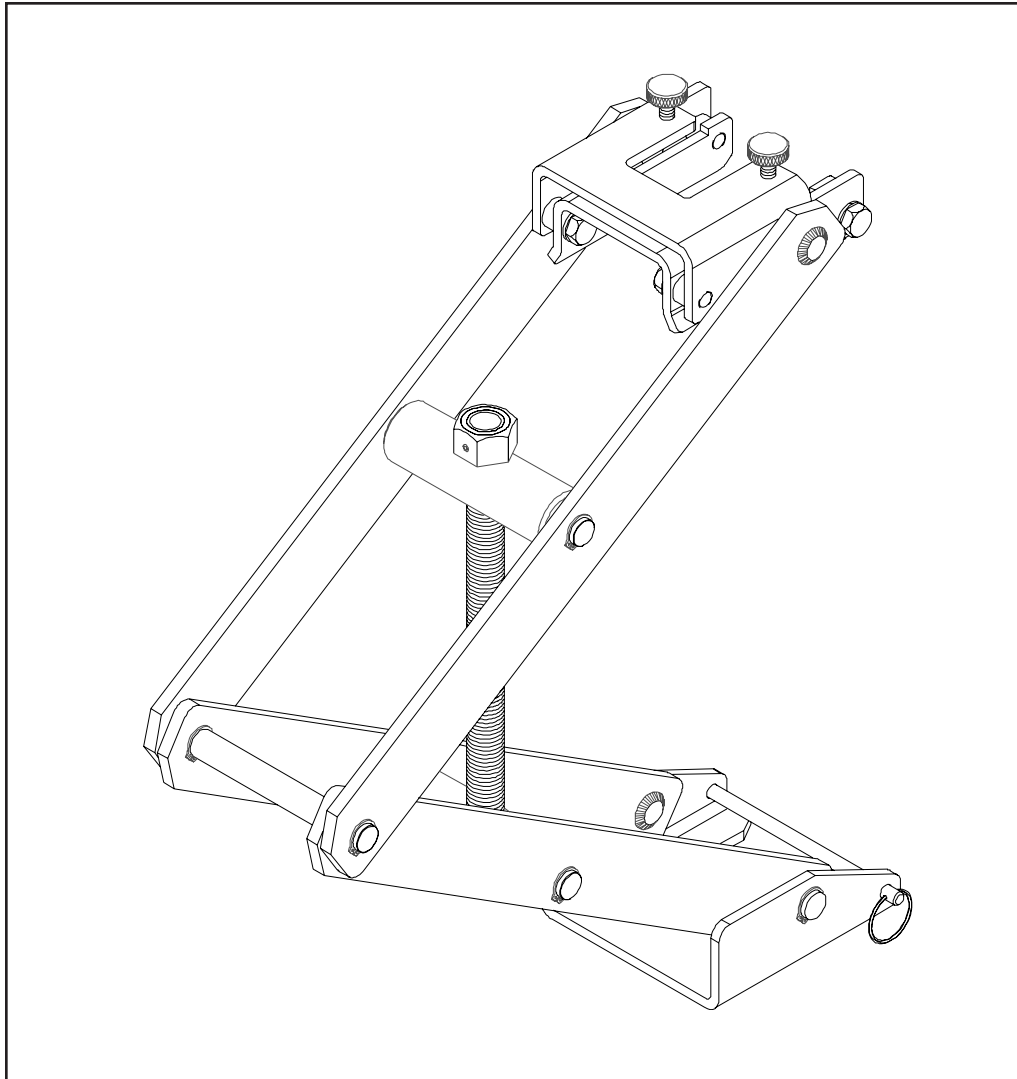

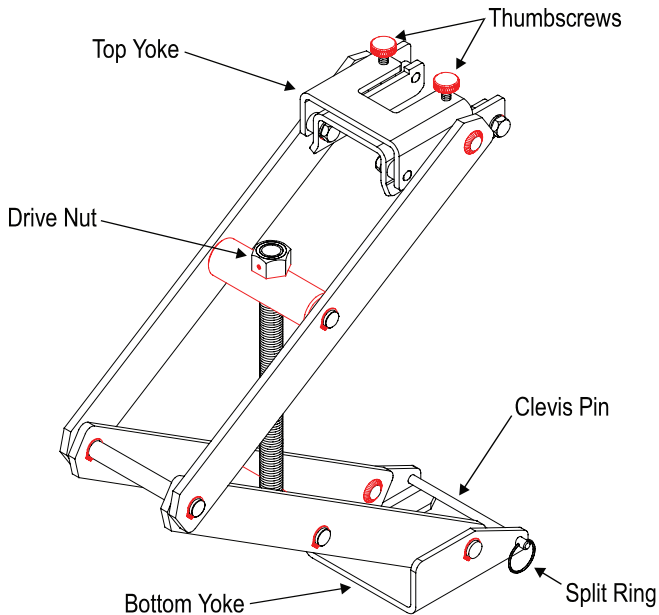

Figure 1

The Model HTT Hot Tap Tool provides the mechanical advantage required to safely insert and remove a Badger Meter hot tap sensor from line pressure and provides a restraint when removing the sensor from a pressurized pipe.

#### Removal of Badger® Series 225/226 from a pressurized pipeline.

**⚠ WARNING** Do not remove lock nuts from threaded rods above the positioning collar without hot tap tool connected. Serious injury could result.

1. Adjust Hot Tap tool opening by rotating drive nut with a 15/16 socket or box wrench (not provided) until the distance between the top and bottom yoke is approximately equal to the distance between the groove on the hex mounting adaptor and the bottom surface of the sensor positioning collar.
2. Remove split ring and clevis pin.
3. Slide tool bottom yoke into the groove in the hex mounting adaptor and secure with the clevis pin and split ring.
4. To permit clearance for the top yoke, lower two of the three pairs of jam nuts under the sensor positioning collar to a minimum of 1½ inches below the positioning collar. Then position the top yoke so the threaded rod with the remaining jam nuts are centered in the yoke. Then slide on the yoke, adjusting with drive nut as necessary.
5. Make sure the positioning collar is located in the recessed area of the yoke by adjusting the drive nut until the top yoke is snug against the bottom of the sensor positioning collar. Then tighten thumb screws located on the top of the tool.
6. Remove three lock nuts above the collar and slowly withdraw sensor by rotating the drive nut of the tool counterclockwise with a 15/16 socket or box wrench (not supplied) until drive nut bottoms out on tool.
7. Close gate or ball valve fully.
8. Open bleed valve located on the hex mounting adaptor to relieve pressure between valve and sensor.
9. Once all pressure is relieved remove tool and remove sensor from the hex adaptor.

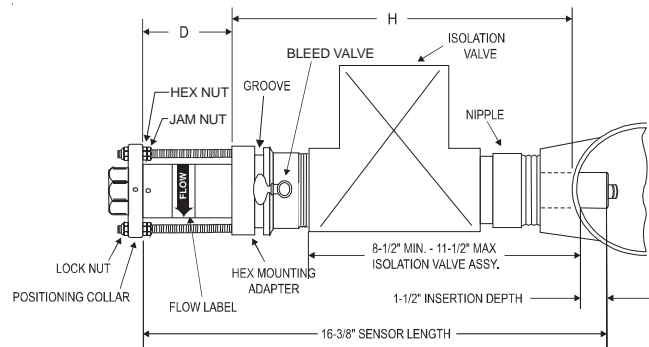

Figure 2

#### Installation into a pressurized pipeline

For pipe sizes 2½ inches and above, all Badger Meter sensors are inserted 1 1/2 inches from the inside wall of the pipe. The insertion depth is controlled by the position of the hex nuts on the three threaded rods. The formula below defines the distance between the top of the sensor hex mounting adaptor and the bottom of the positioning collar (the top of the hex nut). Reference figure 2.

$$D = 16 \frac{3}{8}'' - (H + \text{Pipe Wall Thickness} + 1.5'')$$

Example: If sensor is installed in a 8 inch Sch 80 pipe with a pipe wall thickness of 0.5 inch and the "H" dimension is 10 inch then the calculation would be as below:

$$D = 16 \frac{3}{8}'' - (10'' + 0.5'' + 1.5'')$$

$$D = 4 \frac{3}{8}''$$

1. Set one set of hex/jam nuts so that the distance between the top surface of the hex nut and the top surface of the hex mounting adaptor is equal to the "D" dimension calculated above. Then adjust the other two sets of hex/jam nuts 1½ inches below the first jam nut to allow clearance for the tool top yoke.
2. Fully extend tool by turning drive nut counterclockwise with a 15/16 inch socket or box wrench (not provided) until drive nut contacts tool and slide the positioning collar into the tool top yoke.
3. Remove the tool split ring and clevis pin and slide tool bottom yoke into the groove on the sensor hex mounting adaptor and secure by replacing the clevis pin and split ring.
4. Mark sleeve 2 3/4 inches from impeller end of metal sleeve. This mark is a stopping point to insure that impeller/bearing is not damaged. Open the bleed petcock valve on the hex adapter to relieve the pressure resulting from the sensor tube insertion. Carefully hand insert the Badger Meter hot tap flow sensor sleeve assembly into the hex mounting adaptor until the mark lines up with the top of the hex mounting adaptor. At this point the sleeve will have been inserted past the top two O-rings in the adaptor (approximately 1 - 1 1/4 inches). Take care not to push the sensor past the mark on the sleeve as the impeller could be damaged if it strikes the closed valve.
5. Rotate tool so the threaded rod with the adjusted hex/jam nuts is centered in the top yoke of hot tap tool.
6. Rotate sensor sleeve so positioning collar holes align with the threaded rods, and flow direction label is in general direction making sure the positioning collar is located in the recessed area of the top yoke. Slide the top yoke

- of the tool over the positioning collar and secure by tightening the two thumbscrews on the top of the yoke.
7. Close the bleed petcock and slowly open the isolation valve. Slowly turn the 15/16 inch drive nut clockwise to insert the sensor tube assembly through the valve and into the pipeline. Carefully guide the three threaded studs of the hex mounting adapter through the holes of the sensor positioning collar. Carefully lower the sensor until the positioning collar contacts the hex nut preset for the correct depth adjustment. Install the three lock nuts onto the threaded rods, tightening only the lock nut on the threaded rod with the preset hex/jam nut; then, bring the two remaining lock nuts down until they just contact the positioning collar. Do not tighten at this time
  8. Remove the Model HTT Insertion/Removal Tool, by loosening the two thumbscrews, removing the clevis pin and then sliding the insertion tool off the sensor. Then bring the two remaining sets of hex/jam nuts up to the underside of the positioning collar, and tighten.
  9. Align the sensor by first loosening the two set screws in the side of positioning collar with a 3/32 inch Allen wrench. Then align the sensor sight holes along the pipe axis using the alignment rod provided in the sensor installation kit. Ensure that the flow label arrow on the sensor matches the liquid flow direction inside the pipe. Tighten the positioning collar set screws. Note: As a backup to the flow label arrow, there is a small hole located beside the sight hole on the upstream side of the sensor.

Badger® and Data Industrial® are registered trademarks of Badger Meter, Inc.

---



Please see our website at [www.badgermeter.com](http://www.badgermeter.com)  
for specific contacts.

Copyright © Badger Meter, Inc. 2009. All rights reserved.

Due to continuous research, product improvements and enhancements, Badger Meter reserves the right to change product or system specifications without notice, except to the extent an outstanding contractual obligation exists.



**BadgerMeter, Inc.**

6116 E. 15th Street, Tulsa, Oklahoma 74112

(918) 836-8411 / Fax: (918) 832-9962

[www.badgermeter.com](http://www.badgermeter.com)