

Operating Instructions

pH sensor **CPL51E**

Laboratory sensor with Memosens 2.0 technology

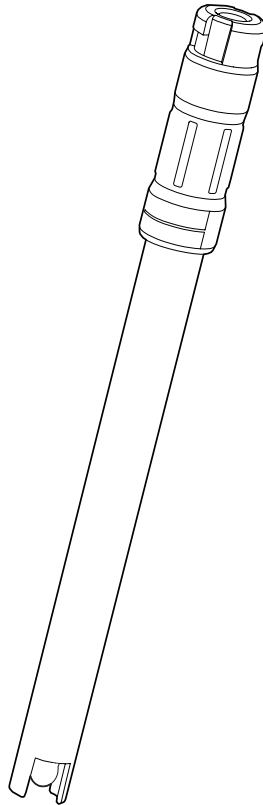





Table of contents







1	About this document	4
1.1	Warnings	4
1.2	Symbols used	4
1.3	Documentation	5
2	Basic safety instructions	6
2.1	Requirements for personnel	6
2.2	Designated use	6
2.3	Workplace safety	6
2.4	Operational safety	6
2.5	Product safety	7
3	Incoming acceptance and product identification	8
3.1	Incoming acceptance	8
3.2	Product identification	8
3.3	Storage and transport	9
3.4	Scope of delivery	9
3.5	Certificates and approvals	9
4	Electrical connection	10
4.1	Connecting the sensor	10
5	Commissioning	11
5.1	Preparatory steps	11
6	Operation	14
6.1	Place of application	14
7	Maintenance	15
7.1	Maintenance tasks	15
8	Repair	16
8.1	Return	16
8.2	Disposal	16
9	Technical data	17
9.1	Input	17
9.2	Environment	17

1 About this document

1.1 Warnings

Structure of information	Meaning
 <p>Causes (/consequences) If necessary, Consequences of non-compliance (if applicable)</p> <ul style="list-style-type: none"> ▶ Corrective action 	<p>This symbol alerts you to a dangerous situation. Failure to avoid the dangerous situation will result in a fatal or serious injury.</p>
 <p>Causes (/consequences) If necessary, Consequences of non-compliance (if applicable)</p> <ul style="list-style-type: none"> ▶ Corrective action 	<p>This symbol alerts you to a dangerous situation. Failure to avoid the dangerous situation can result in a fatal or serious injury.</p>
 <p>Causes (/consequences) If necessary, Consequences of non-compliance (if applicable)</p> <ul style="list-style-type: none"> ▶ Corrective action 	<p>This symbol alerts you to a dangerous situation. Failure to avoid this situation can result in minor or more serious injuries.</p>
 <p>Cause/situation If necessary, Consequences of non-compliance (if applicable)</p> <ul style="list-style-type: none"> ▶ Action/note 	<p>This symbol alerts you to situations which may result in damage to property.</p>

1.2 Symbols used

Symbol	Meaning
	Additional information, tips
	Permitted or recommended
	Not permitted or not recommended
	Reference to device documentation
	Reference to page
	Reference to graphic
	Result of a step

1.2.1 Symbols on the device

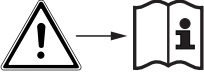
Symbol	Meaning
	Reference to device documentation

1.3 Documentation

The following manuals which complement these Operating Instructions can be found on the product pages on the Internet:

- Technical Information for the relevant sensor
- Operating Instructions for the transmitter used
- Operating Instructions for the laboratory instruments Liquiline Mobile and Memobase Plus

2 Basic safety instructions

2.1 Requirements for personnel

- Installation, commissioning, operation and maintenance of the measuring system may be carried out only by specially trained technical personnel.
- The technical personnel must be authorized by the plant operator to carry out the specified activities.
- The electrical connection may be performed only by an electrical technician.
- The technical personnel must have read and understood these Operating Instructions and must follow the instructions contained therein.
- Faults at the measuring point may only be rectified by authorized and specially trained personnel.



Repairs not described in the Operating Instructions provided must be carried out only directly at the manufacturer's site or by the service organization.

2.2 Designated use

The pH sensor CPL51E is designed for short-term measurements in the laboratory environment or in the field.

The pH sensor CPL51E is not intended for continuous measurement and permanent installation in the process or in assemblies.

Use of the device for any purpose other than that described, poses a threat to the safety of people and of the entire measuring system and is therefore not permitted.

The manufacturer is not liable for damage caused by improper or non-designated use.

2.3 Workplace safety

As the user, you are responsible for complying with the following safety conditions:

- Installation guidelines
- Local standards and regulations

2.4 Operational safety

Before commissioning the entire measuring point:

1. Verify that all connections are correct.
2. Ensure that electrical cables and hose connections are undamaged.
3. Do not operate damaged products, and protect them against unintentional operation.
4. Label damaged products as defective.

During operation:

- ▶ If faults cannot be rectified:
products must be taken out of service and protected against unintentional operation.

2.5 Product safety

2.5.1 State-of-the-art technology

The product is designed to meet state-of-the-art safety requirements, has been tested, and left the factory in a condition in which it is safe to operate. The relevant regulations and international standards have been observed.

3 Incoming acceptance and product identification

3.1 Incoming acceptance

1. Verify that the packaging is undamaged.
 - ↳ Notify the supplier of any damage to the packaging.
Keep the damaged packaging until the issue has been resolved.
2. Verify that the contents are undamaged.
 - ↳ Notify the supplier of any damage to the delivery contents.
Keep the damaged goods until the issue has been resolved.
3. Check that the delivery is complete and nothing is missing.
 - ↳ Compare the shipping documents with your order.
4. Pack the product for storage and transportation in such a way that it is protected against impact and moisture.
 - ↳ The original packaging offers the best protection.
Make sure to comply with the permitted ambient conditions.

If you have any questions, please contact your supplier or your local Sales Center.

3.2 Product identification

3.2.1 Nameplate

The nameplate provides you with the following information on your device:

- Manufacturer details
- Order code
- Serial number
- Safety information and warnings

► Compare the information on the nameplate with the order.

3.2.2 Identifying the product

Product page

www.endress.com/CPL51E

Interpreting the order code

The order code and serial number of your product can be found in the following locations:

- On the nameplate
- In the delivery papers

Obtaining information on the product

1. Go to www.endress.com.
2. Call up the site search (magnifying glass).
3. Enter a valid serial number.

4. Search.

- ↳ The product structure is displayed in a popup window.

5. Click on the product image in the popup window.

- ↳ A new window (**Device Viewer**) opens. All of the information relating to your device is displayed in this window as well as the product documentation.

3.2.3 Manufacturer's address

Endress+Hauser Conducta GmbH+Co. KG
Dieselstraße 24
D-70839 Gerlingen

3.3 Storage and transport

All sensors are individually tested and supplied in individual packs. The sensors are equipped with a moistening cap with a bayonet lock. The cap contains a special liquid that prevents the sensor from drying out.

- ▶ If a moistening cap is not used to store the sensor, store the sensor in a KCl solution (3 mol/l) or buffer solution.



Do not allow the sensor to dry out, as this can result in permanent measurement errors.

Sensors must be stored in dry rooms at temperatures of 0 to 50 °C (32 to 122 °F).

NOTICE

Freezing of internal buffer and inner electrolyte!

The sensors can crack at temperatures lower than -15 °C (5 °F).

- ▶ If transporting the sensors, make sure to package them so they are appropriately protected against frost.

3.4 Scope of delivery

The delivery comprises:

- Sensor in the version ordered
- Operating Instructions

3.5 Certificates and approvals

3.5.1 CE mark

The product meets the requirements of the harmonized European standards. As such, it complies with the legal specifications of the EU directives. The manufacturer confirms successful testing of the product by affixing to it the **CE** mark.

4 Electrical connection

⚠ WARNING

Device is live!

Incorrect connection may result in injury or death!

- ▶ The electrical connection may be performed only by an electrical technician.
- ▶ The electrical technician must have read and understood these Operating Instructions and must follow the instructions contained therein.
- ▶ **Prior** to commencing connection work, ensure that no voltage is present on any cable.

4.1 Connecting the sensor

4.1.1 Connection to handheld device

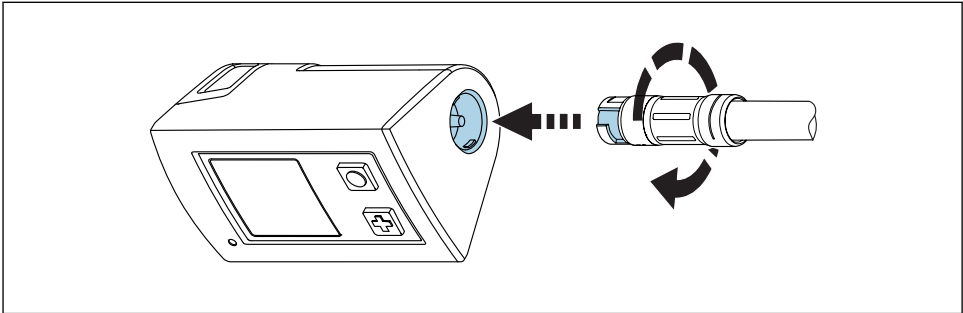

A0041682

1 Sensor connection

- ▶ Insert the sensor into the Memosens connection and click it into place.

4.1.2 Connection to handheld device via M12 cable

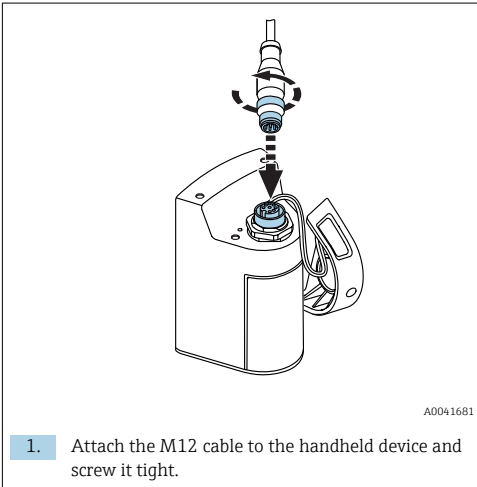

A0041681

1. Attach the M12 cable to the handheld device and screw it tight.

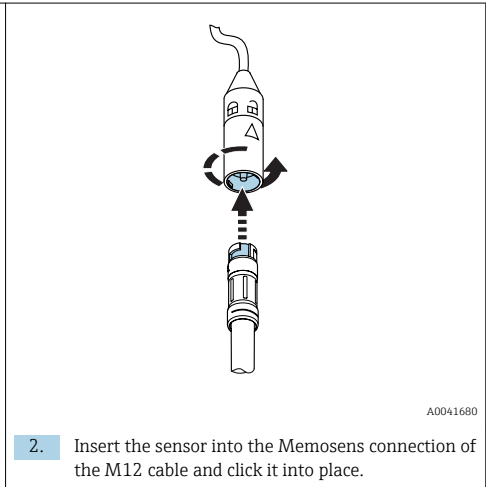

A0041680

2. Insert the sensor into the Memosens connection of the M12 cable and click it into place.

5 Commissioning

5.1 Preparatory steps

Before commissioning the sensor, remove the moistening cap with the bayonet lock:

1. Turn the top part of the moistening cap.

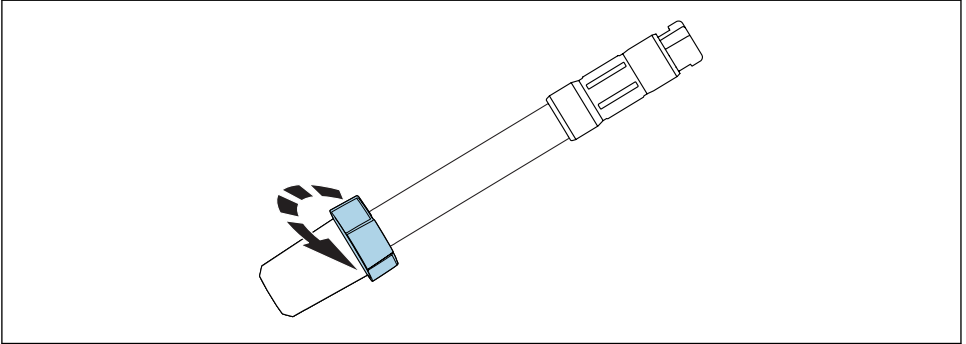

A0041683

2. Carefully remove the moistening cap from the sensor.

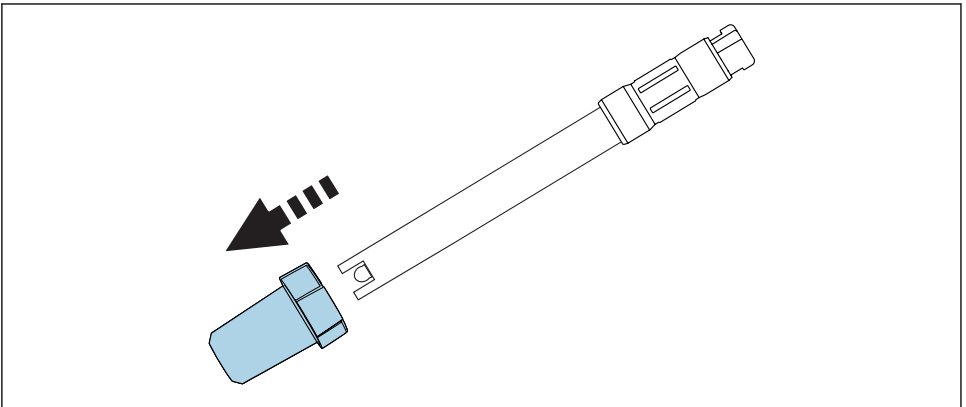

A0041684

5.1.1 Calibration and adjustment

The frequency with which a sensor calibration or sensor check is performed depends on the operating conditions, e.g. contamination and chemical load.

i New pH sensors with Memosens technology do not need to be calibrated. Calibration is only required if very strict accuracy requirements must be met, or if the sensor has been in storage for longer than 3 months.

Two-point calibration is required for pH sensors. Use a high-quality buffer from Endress+Hauser, e.g. CPY20, for this purpose.

Calibrating and adjusting the pH sensor:

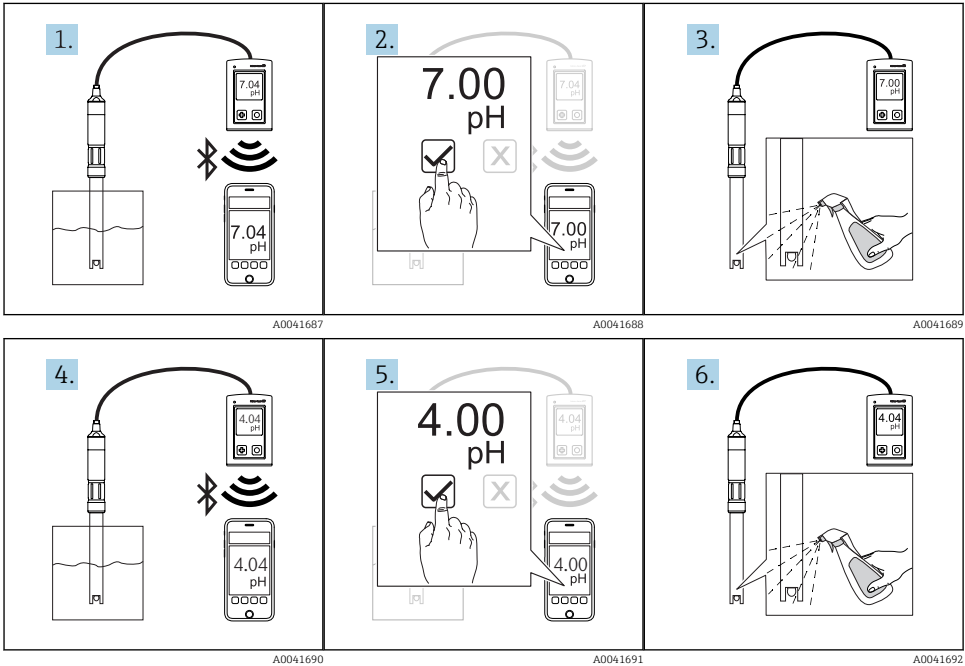

1. Immerse the sensor into a defined buffer solution (e.g. pH 7). Where applicable, connect the handheld device to a mobile terminal via Bluetooth and the SmartBlue App.

2. Perform the calibration at the transmitter or using the SmartBlue App:

(a) In the case of pH sensors and manual temperature compensation, set the measurement temperature.

(b) Enter the pH value of the buffer solution.

(c) Start the calibration.

(d) The value is accepted once it has stabilized.

3. Rinse the sensor with distilled water. Do not dry the sensor!

4. Immerse the sensor into the second buffer solution (e.g. pH 4).
5. Perform the calibration at the transmitter or using the SmartBlue App:
 - (a) Enter the pH value of the second buffer solution.
 - (b) Start the calibration.
 - (c) The value is accepted once it has stabilized.
6. Rinse the sensor with distilled water.



The use of automatic temperature compensation (ATC) is recommended for calibration and measurement.

The transmitter or the SmartBlue App calculates the zero point and slope and displays the values. The sensor is adjusted once the values are accepted.

6 Operation

6.1 Place of application

NOTICE

High ambient temperatures

Risk of damaging the Memosens connection!

- ▶ Do not expose the Memosens connection to temperatures above 50 °C (122 °F).

NOTICE

Incorrect immersion depth

Risk of damaging the sensor!

- ▶ Only immerse the shaft of the sensor into the medium.
- ▶ Avoid any contact between the Memosens connection and the medium.
- Do not use the sensor upside-down.
- The angle of application from the horizontal must be at least 15°.

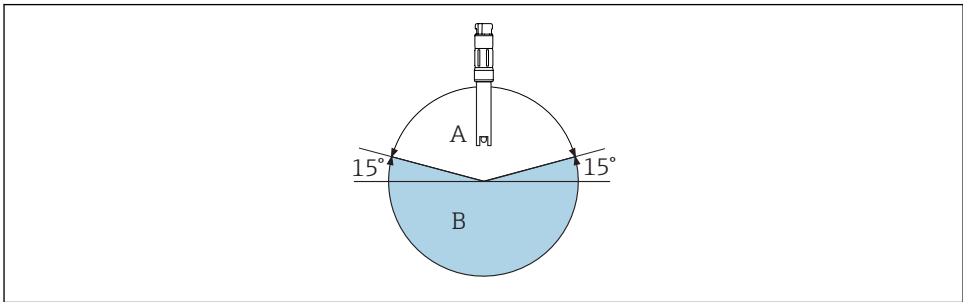

A0041669

2 Angle of application at least 15° from the horizontal

A Permitted angle of application

B Impermissible angle of application

Put the sensor into operation only if you can answer "yes" to the following questions:

- Are the sensor and cable undamaged?
- Is the angle of application correct?

7 Maintenance

7.1 Maintenance tasks

7.1.1 Cleaning the sensor

- ▶ First rinse the sensor with clear water.

WARNING

Mineral acids and hydrofluoric acid

Risk of serious or fatal injury from caustic burns!

- ▶ Wear goggles to protect eyes.
- ▶ Wear protective gloves and appropriate protective clothing.
- ▶ Avoid all contact with the eyes, mouth and skin.
- ▶ If using hydrofluoric acid, use plastic vessels only.

WARNING

Thiocarbamide

Harmful if swallowed! Limited evidence of carcinogenicity! Possible risk of harm to the unborn child! Dangerous for the environment with long-term effects!

- ▶ Wear protective goggles, protective gloves and appropriate protective clothing.
- ▶ Avoid all contact with the eyes, mouth and skin.
- ▶ Avoid discharge into the environment.

Clean away fouling on the sensor as follows depending on the type of fouling:

1. Oily and greasy films:
Clean with fat solvent, e.g. alcohol, or hot water and agents containing surfactants (alkaline) (e.g. dishwashing detergent).
2. Lime and metal hydroxide buildup and low solubility (lyophobic) organic buildup:
Dissolve buildup with diluted hydrochloric acid (3 %) and then rinse thoroughly with plenty of clear water.
3. Sulfidic buildup (from flue gas desulfurization or wastewater treatment plants):
Use a mixture of hydrochloric acid (3 %) and thiocarbamide (commercially available) and then rinse thoroughly with plenty of clear water.
4. Buildup containing proteins (e.g. food industry):
Use a mixture of hydrochloric acid (0.5 %) and pepsin (commercially available) and then rinse thoroughly with plenty of clear water.
5. Readily soluble biological buildup:
Rinse with pressurized water.

After cleaning, rinse the sensor thoroughly with water and then recalibrate.

8 Repair

8.1 Return

The product must be returned if repairs or a factory calibration are required, or if the wrong product was ordered or delivered. As an ISO-certified company and also due to legal regulations, Endress+Hauser is obliged to follow certain procedures when handling any returned products that have been in contact with medium.

To ensure the swift, safe and professional return of the device:

- ▶ Refer to the website www.endress.com/support/return-material for information on the procedure and conditions for returning devices.

8.2 Disposal

The device contains electronic components. The product must be disposed of as electronic waste.

- ▶ Observe the local regulations.

9 Technical data

9.1 Input

9.1.1 Measured variable

- pH value
- Temperature

9.1.2 Measuring range

- pH value: 0 to 14 pH
optimized between 1 to 12 pH
- Temperature: 0 to 80 °C (32 to 176 °F)

9.2 Environment

9.2.1 Ambient temperature range

0 to 45 °C (32 to 104 °F)

9.2.2 Storage temperature

0 to 50 °C (32 to 122 °F), non-freezing



71465076

www.addresses.endress.com
