

Aurora H2O

User's Manual



ATTENTION!

This manual is only for devices with serial number 4000 (software v.002.A) or higher. [For devices with lower serial numbers than 4000 refer to manual BH003C12].

Aurora H2O

Moisture Analyzer for Natural Gas

User's Manual

BH003C11 EN C
April 2023

panametrics.com

Copyright 2023 Baker Hughes company.

This material contains one or more registered trademarks of Baker Hughes Company and its subsidiaries in one or more countries. All third-party product and company names are trademarks of their respective holders.

[no content intended for this page]

Services

BH provides customers with an experienced staff of customer support personnel ready to respond to technical inquiries, as well as other remote and on-site support needs. To complement our broad portfolio of industry-leading solutions, we offer several types of flexible and scalable support services including: Training, Product Repairs, Service Agreements and more. Please visit <https://www.bakerhughes.com/panametrics/panametrics-services> for more details.

Typographical Conventions

Note: *These paragraphs provide information that provides a deeper understanding of the situation, but is not essential to the proper completion of the instructions.*

IMPORTANT: These paragraphs provide information that emphasizes instructions that are essential to proper setup of the equipment. Failure to follow these instructions carefully may cause unreliable performance.



CAUTION! This symbol indicates a risk of potential minor personal injury and/or severe damage to the equipment, unless these instructions are followed carefully.



WARNING! This symbol indicates a risk of potential serious personal injury, unless these instructions are followed carefully.

Safety Issues



WARNING! It is the responsibility of the user to make sure all local, county, state and national codes, regulations, rules and laws related to safety and safe operating conditions are met for each installation.



Attention European Customers! To meet CE Mark requirements for all units intended for use in the EU, all electrical cables must be installed as described in this manual.

Auxiliary Equipment

Local Safety Standards

The user must make sure that he operates all auxiliary equipment in accordance with local codes, standards, regulations, or laws applicable to safety.

Working Area



WARNING! Auxiliary equipment may have both manual and automatic modes of operation. As equipment can move suddenly and without warning, do not enter the work cell of this equipment during automatic operation, and do not enter the work envelope of this equipment during manual operation. If you do, serious injury can result.



WARNING! Make sure that power to the auxiliary equipment is turned OFF and locked out before you perform maintenance procedures on this equipment.

Qualification of Personnel

Make sure that all personnel have manufacturer-approved training applicable to the auxiliary equipment.

Personal Safety Equipment

Make sure that operators and maintenance personnel have all safety equipment applicable to the auxiliary equipment. Examples include safety glasses, protective headgear, safety shoes, etc.

Unauthorized Operation

Make sure that unauthorized personnel cannot gain access to the operation of the equipment.

Environmental Compliance

RoHS

The Aurora H2O fully complies with RoHS regulations.

Waste Electrical and Electronic Equipment (WEEE) Directive

Panametrics is an active participant in Europe's *Waste Electrical and Electronic Equipment (WEEE)* take-back initiative, directive 2012/19/EU.

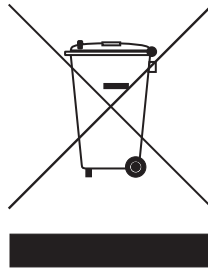

The equipment that you bought has required the extraction and use of natural resources for its production. It may contain hazardous substances that could impact health and the environment.

In order to avoid the dissemination of those substances in our environment and to diminish the pressure on the natural resources, we encourage you to use the appropriate take-back systems. Those systems will reuse or recycle most of the materials of your end of life equipment in a sound way.

The crossed-out wheeled bin symbol invites you to use those systems.

If you need more information on the collection, reuse and recycling systems, please contact your local or regional waste administration.

Chapter 1. Features and Capabilities 1

1.1 Overview1

1.2 Features1

1.3 Theory of Operation 2

1.4 Specifications 9

 1.4.1 Range 9

 1.4.2 Accuracy 9

 1.4.3 Response Time 9

 1.4.4 Pressure 9

 1.4.5 Flow Rate 10

 1.4.6 Inputs/Outputs 10

 1.4.7 Enclosure 10

 1.4.8 Temperature 10

 1.4.9 Hazardous Area Certification 11

Chapter 2. Installation 13

2.1 Introduction13

2.2 Bill of Materials13

2.3 Unpacking13

2.4 Choosing A Site for Installation 14

2.5 Low Voltage Directive 16

2.6 Mounting 16

2.7 Optional Insertion Probe/Regulator 16

 2.7.1 Description 16

 2.7.2 Installation 17

 2.7.3 Setting the Pressure 24

2.8 Making Electrical Connections 25

2.9 Specific Conditions of Use 30

Chapter 3. Operation and General Programming 33

3.1 Using the Aurora H2O 33

3.2 Sample System 33

 3.2.1 Aurora H2O Startup 33

 3.2.2 Aurora H2O Shut Down 34

 3.2.3 Service Gas Connection 34

3.3 Keypad Features 36

 3.3.1 Indicator Lights 37

 3.3.2 The Magnetic Stylus 37

 3.3.3 The Default Display 37

 3.3.4 Unlocking the Keypad 38

 3.3.5 Keypad Lock-Out Switch 38

 3.3.6 Accessing the Menus 39

 3.3.7 Entering Numeric Values 39

 3.3.8 Starting Up 40

3.4 Setting Up the Display 40

 3.4.1 Selecting Primary Units 40

 3.4.2 Selecting Alt 1 and Alt 2 Units 41

 3.4.3 Setting Decimal Places 41

 3.4.4 Data/Scan 41

 3.4.5 Adjust 42

 3.4.6 Reverse 42

3.5	Setting Up the Outputs.....	42
3.5.1	Selecting an Output for Setup.....	42
3.5.2	Selecting Output Units.....	43
3.5.3	Selecting an Output Type.....	43
3.5.4	Changing the Upper Output Span.....	43
3.5.5	Changing the Lower Output Span.....	44
3.5.6	NAMUR Response.....	44
3.5.7	Testing the Output.....	45
3.5.8	Trimming the Outputs.....	46
3.6	Setting Up the Alarms.....	47
3.6.1	Selecting an Alarm Output.....	47
3.6.2	Selecting Alarm Status.....	48
3.6.3	Selecting Alarm Units.....	48
3.6.4	Selecting an Alarm Type.....	49
3.6.5	How the Alarm Types Work.....	49
3.6.6	Changing the Upper Alarm Span.....	50
3.6.7	Changing the Lower Alarm Span.....	50
Chapter 4. Programming Advanced Features		51
4.1	Comm Port Settings.....	51
4.1.1	Selecting a Comm Port.....	51
4.1.2	Setting the Baud Rate.....	51
4.1.3	Setting the Parity.....	52
4.1.4	Selecting the Protocol.....	52
4.1.5	Setting the Network ID.....	52
4.1.6	Adjusting the Response Delay.....	53
4.1.7	Serial Port Test.....	53
4.2	Ethernet Settings.....	54
4.2.1	Connection to the Internet/WAN.....	54
4.2.2	Default Passwords.....	54
4.2.3	Connecting to an Ethernet LAN.....	55
4.2.4	IP Address Assignment.....	55
4.2.5	Device Discovery.....	56
4.3	Adjust Offset Values.....	57
4.3.1	Adjusting the PPMv Offset.....	57
4.3.2	Adjusting the Smoothing Filter.....	57
4.3.3	Adjusting the Scan Averaging.....	58
4.3.4	Setting the Dew Point Calculation Method.....	58
4.3.5	Saturation Calculation.....	59
4.4	Set Up the Background Gas.....	59
4.4.1	Selecting the Type of Gas.....	59
4.4.2	Setting the Z Factor.....	60
4.4.3	Entering a Label.....	61
4.4.4	Adjusting the Gas Offset.....	62
4.5	Clock Settings.....	63
4.5.1	Resetting the Hour.....	63
4.5.2	Resetting the Minutes.....	63
4.5.3	Resetting the Month.....	63
4.5.4	Resetting the Date.....	64
4.5.5	Resetting the Year.....	64
4.6	Pressure Settings.....	65
4.6.1	Setting Pressure Units.....	65
4.6.2	Setting the Source.....	65
4.6.3	Changing the Constant.....	65
4.6.4	Editing Pressure Calibration.....	66

4.7	Regional Settings	67
4.7.1	Setting the Country Code	67
4.7.2	Setting the Decimal Format	68
4.7.3	Setting the Date Format	68
4.7.4	Setting the Unit System	68
4.8	User Calibration	69
4.9	Service Settings	71
4.10	Aurora H2O Information	71
4.10.1	Checking the ID	71
4.10.2	Checking the System Status	71
4.10.3	Checking the Software	72
4.10.4	Checking the Gas Composition	72
4.10.5	Checking the Alternate Gas Composition	73
4.11	Locking/Unlocking the Display	73
Chapter 5. AuroraView Interface Software		77
5.1	Capabilities	77
5.2	Requirements	77
5.3	Installing AuroraView	78
5.4	Starting AuroraView	85
5.5	Using the Main Menus	87
5.6	Datalogging with AuroraView	93
5.7	Working with Trend Plots, Trend Tabular Data and Scan Plots	94
Chapter 6. Maintenance		101
6.1	Spare Parts	101
6.2	Cleaning the Mirror	101
6.2.1	Instructions for Optical Absorption Cell Style 1	103
6.2.2	Instructions for Optical Absorption Cell Style 2	108
6.3	Replacing the Filter Element	112
Chapter 7. Troubleshooting		115
7.1	Introduction	115
7.2	Blank Display	115
7.3	Display Dim or Hard to Read	115
7.4	Status Messages and Indicators	115
7.5	No Flow Measurement Indicated on Aurora H2O Measurement Cell Outlet	117
7.6	Verifying Aurora H2O Performance in the Field	117
7.6.1	Using A Portable Hygrometer	117
7.6.2	Using a Moisture Standard	118
7.7	Background Selection Lockout	118
Appendix A. MODBUS RTU/TCP Communications		121
A.1	Introduction	121
A.2	Modbus Functions and Data Types	121
A.3	Modbus Registers	122
A.4	Modbus System Status Codes	128
Appendix B. Aurora H2O Ethernet Operation		129
B.1	Introduction	129
B.1.1	Connection to the Internet/WAN	129
B.1.2	Default Passwords	129
B.1.3	Open Ports and Services Warning	129
B.1.4	Initial Setup	129
B.2	Device Discovery	129
B.3	User Accounts	131
B.3.1	The Root Account	131
B.3.2	The Operator Account	134

B.4	Communicating by MODBUS via Ethernet.....	135
B.4.1	MODBUS/TCP.....	135
B.4.2	MODBUS/RTU.....	136
B.5	Using TELNET for Configuration.....	137
B.6	Using the MS Windows Telnet Client.....	138

Chapter 1. Features and Capabilities

1.1 Overview

Panametrics's **Aurora H2O** *Moisture Analyzer for Natural Gas* makes it possible for natural gas processing and transportation facilities to monitor moisture content in real-time with high precision and reliability.

The **Aurora H2O** analyzer uses tunable diode laser absorption spectroscopy (TDLAS) to measure moisture in natural gas at the speed of light. The analyzer is suitable for installation in hazardous areas and operates over a wide range of environmental conditions. **Aurora's** fast response quickly alerts and documents when moisture concentrations are out of compliance. Once process upsets are corrected and the gas dries out, the fast response quickly enables natural gas to be cleared for entry into the "energy grid".

CLASS 1 LASER PRODUCT



WARNING! Use of controls or adjustments or the performance of procedures other than those specified herein may result in hazardous laser exposure.

1.2 Features

- Optical response: < 2 seconds after flow cell is purged
- No cross sensitivity to glycols or amines
- Direct readout in lbs/mmscf, mg/m³ or ppm
- Reads process pressure dew point (with user programmable constant or live auxiliary input for process pressure)
- Turnkey sampling system specifically designed for natural gas applications ensures measurement integrity
- Magnetic Stylus enables through-glass programming – hot permit not required to field program
- Explosion-proof/Flameproof design
- 4-20 mA signals, RS-232/485 MODBUS RTU for connection to SCADA or plant monitoring system, and Ethernet MODBUS/TCP
- Supplied with **AuroraView** software for remote configuration, data logging and data retrieval capacity
- NIST traceable calibration
- In conformance with IEC 60825-1 Edition 2.0, Safety of Laser Products

1.3 Theory of Operation

The Panametrics **Aurora H2O** (TDLAS) hygrometer for natural gas is a system designed to continuously monitor the moisture content in natural gas. It fundamentally measures the partial pressure of water vapor (water in the gas state), and with the simultaneous measurement of pressure and temperature, provides readings and both analog and digital signal transmission of user-selectable moisture parameters including dew point temperature, volume ratio and absolute humidity (lbs/MMSCF or mg/m³) in addition to temperature and pressure.

The **Aurora H2O** is supplied with an integrated sampling system which includes an optional pipe-mounted liquid separator and pressure reducing valve/regulator, and the following components mounted within a stainless steel enclosure: isolation valve, liquid membrane filter, sample cell control valve, second pressure reducing valve/regulator, and flow indicator (rotameter), as well as an optional electrical heater and thermostat.

The fundamental water vapor pressure measurement is based on the *Beer-Lambert Law*:

$$A = \ln\left(\frac{I_0}{I}\right) = SLN$$

where: A = Absorbance

I = Light intensity transmitted through a sample gas

I₀ = Incident light intensity

S = Absorption coefficient*

L = Absorption path length (a constant)

N = Concentration of the water vapor in the absorption cell

* The absorption coefficient is a constant for a specific gas composition at a given pressure and temperature.

The concentration of the water is directly related to the partial pressure. At certain specific frequencies/wavelengths of light, light energy will be absorbed by water molecules. As the concentration of water increases, the absorption also increases. The **Aurora H2O** sweeps the diode laser output across a narrow band in the near infrared spectrum and, by measuring the light intensity with a photodetector, is able to provide a direct indication of the partial pressure of water. The partial pressure, multiplied by 10⁶ and divided by the total pressure, yields the volume ratio in ppm_v (parts per million by volume).

The laser diode is housed in a hermetically sealed and dry housing. The light is transmitted through a window made of proprietary transparent material. The light travels through a stainless steel cell and is reflected off a gold-plated mirror and returned to a photo detector, where the light intensity is measured.

1.3 Theory of Operation (cont.)

Since only light comes in contact with the sample of natural gas, and all of the wetted materials are made of non-corrosive and inert materials, this technology does not exhibit the drift associated with gas contacting sensor-based hygrometers. The diode laser emits low energy light, and therefore the system will not ignite the gas. The complete system is rated explosion-proof, and the **Aurora H2O** provides very fast response time. Once the absorption cell (see *Figure 1* below) is purged, the response time is a matter of a few seconds.

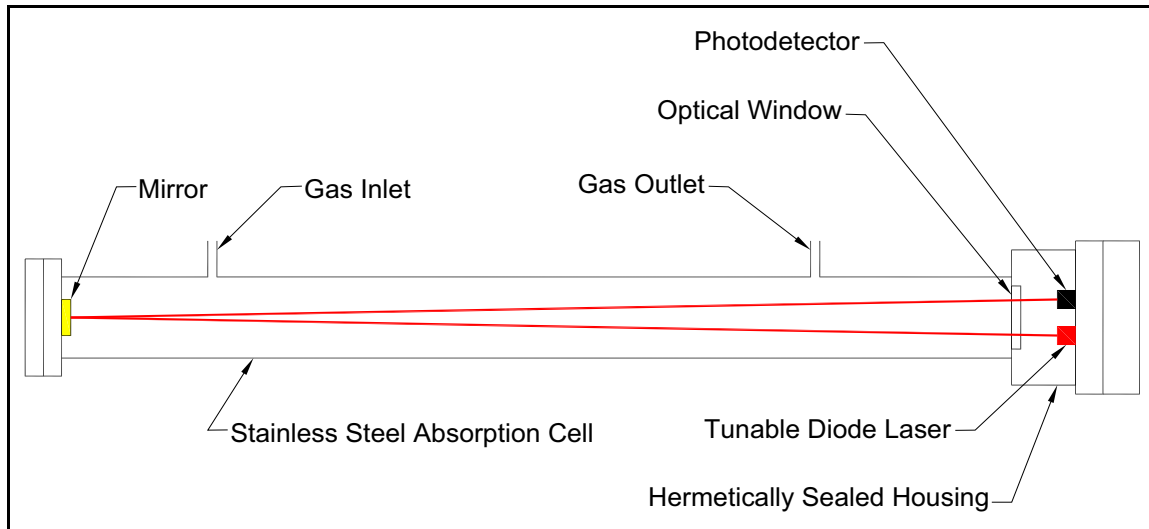

Figure 1: Laser Absorption Cell, Basic Elements

The control of the laser, power supply and signal conditioning circuitry are housed in an explosion-proof transmitter enclosure. A backlit, three-parameter, LCD display provides digital indication of user-programmable parameters. The **Aurora H2O** has three user-programmable (4-20 mA) analog outputs and two programmable digital ports that may be configured as either RS-485 or RS-232 with Modbus protocol. The analyzer has an auxiliary analog input (4-20 mA) input that is used for connection to an optional process pressure transmitter. Measurement of the process pressure enables the **Aurora H2O** to display and transmit the process dew point. **AuroraView** software is provided and enables remote readings, programming data logging and data logging with a personal computer.

The **Aurora H2O** hygrometer is calibrated against an NIST (or other national metrological institute) traceable reference dew point generator and hygrometer. Each system is supplied with a certificate of calibration and functional test data.

1.3 System Components (cont.)

Note: Refer to Figure 2 below and Table 1 on page 6 to identify your Aurora components.

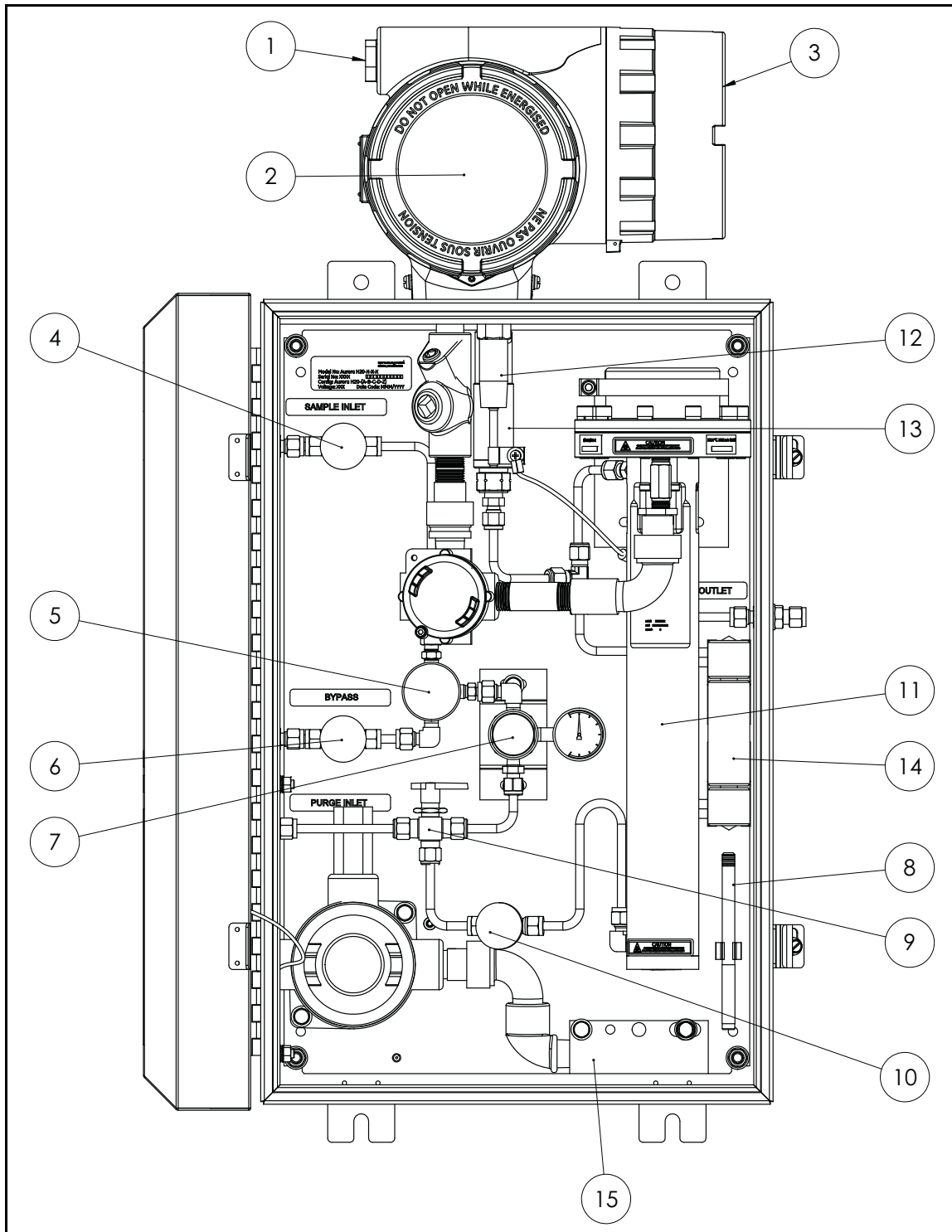

Figure 2: Aurora H2O System Assembly with Optional USA/CAN Heater

1.3 System Components (cont.)

Note: Refer to Figure 3 below and Table 1 on page 6 to identify your Aurora components.

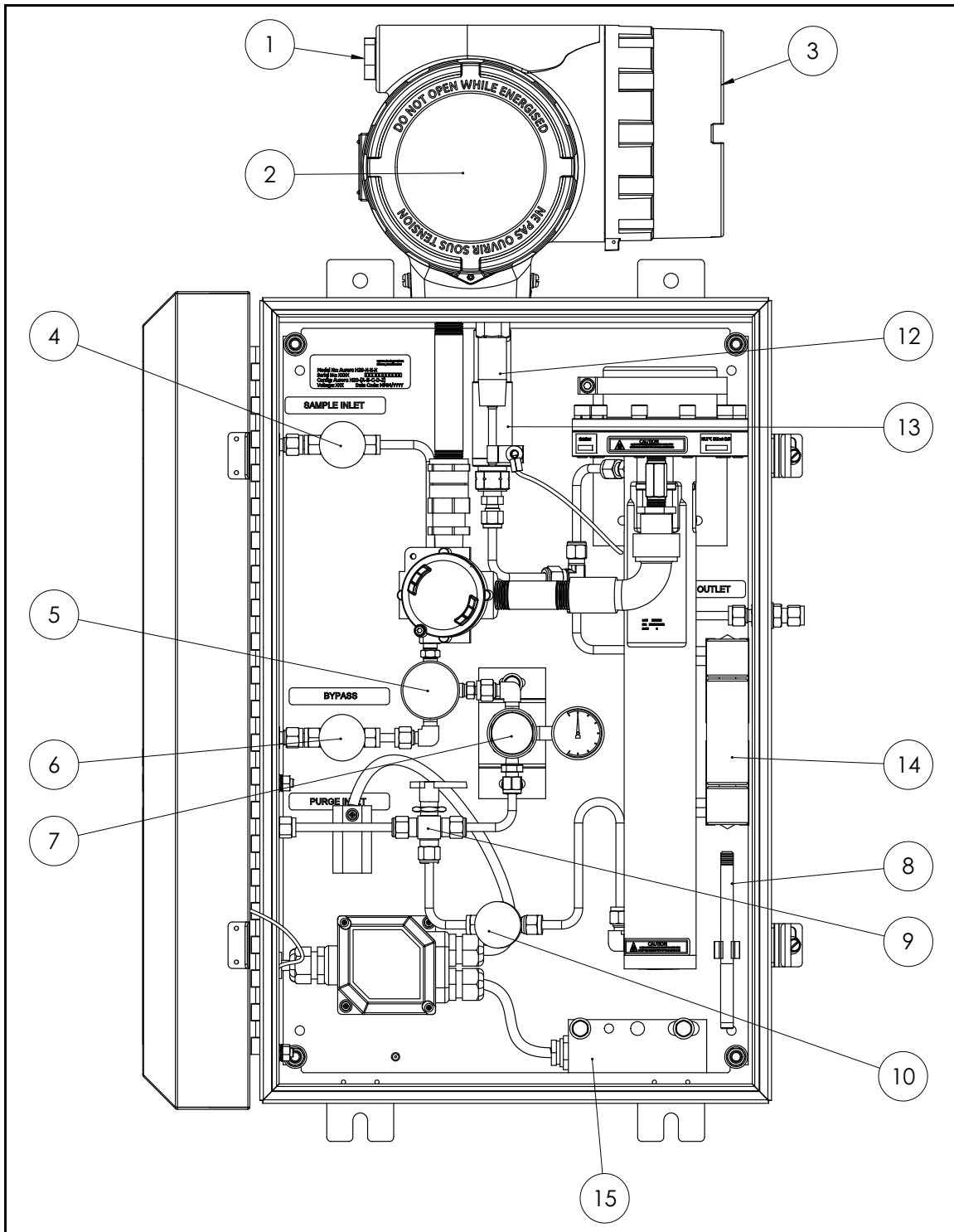

Figure 3: Aurora H2O System Assembly with Optional EU/ATEX Heater

1.3 System Components (cont.)

Note: Refer to Table 1 below and either Figure 2 on page 4 or Figure 3 on page 5 to identify your Aurora components.

Table 1: Aurora H2O System Parts List

No.	Description
1	Power and Signal I/O Conduit
2	Display and Magnetic Stylus Keypad
3	Wiring Terminals
4	Isolation Valve (needle valve)
5	Membrane Filter
6	Membrane Filter Drain & Fast Loop Vent
7	Pressure Regulator w/ 0-10 psig outlet pressure gauge
8	Magnetic Stylus
9	Process or Purge Gas Selector
10	Purge Gas Inlet Needle Valve
11	Absorption Cell
12	Temperature Sensor
13	Pressure Sensor
14	Rotameter
15	Optional Heater, thermostat, junction box

1.3 System Components (cont.)

IMPORTANT: The filter installed within the Aurora is designed to function as a secondary filter. A primary filter or filter train should be used upstream of the analyzer. Do not sample directly from the process gas to the Aurora without the use of a primary filter and pressure reduction. The pressure inlet to the Aurora sample inlet should not exceed 500 psig.

For natural gas, a pipeline insertion membrane filter is recommended as shown in *Figure 4* below. The installation of the insertion filter is described in this manual. The insertion filter also is equipped with a pressure regulator which functions to reduce the pressure. If it is not possible to install the insertion filter, consult Panametrics application engineers for information about a sample conditioning system.

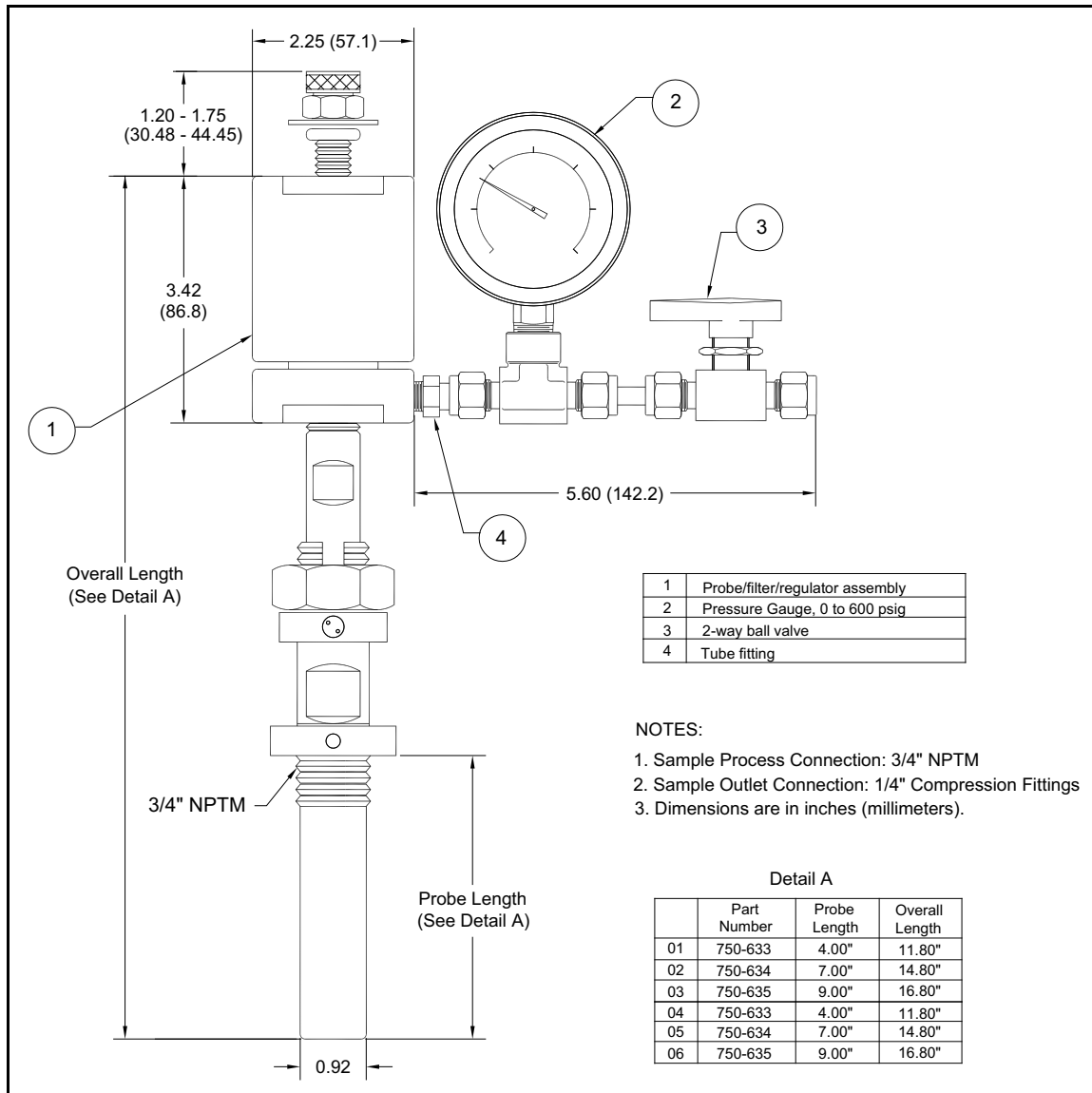

Figure 4: Sample System (ref. dwg #733-737)

1.3 System Components (cont.)

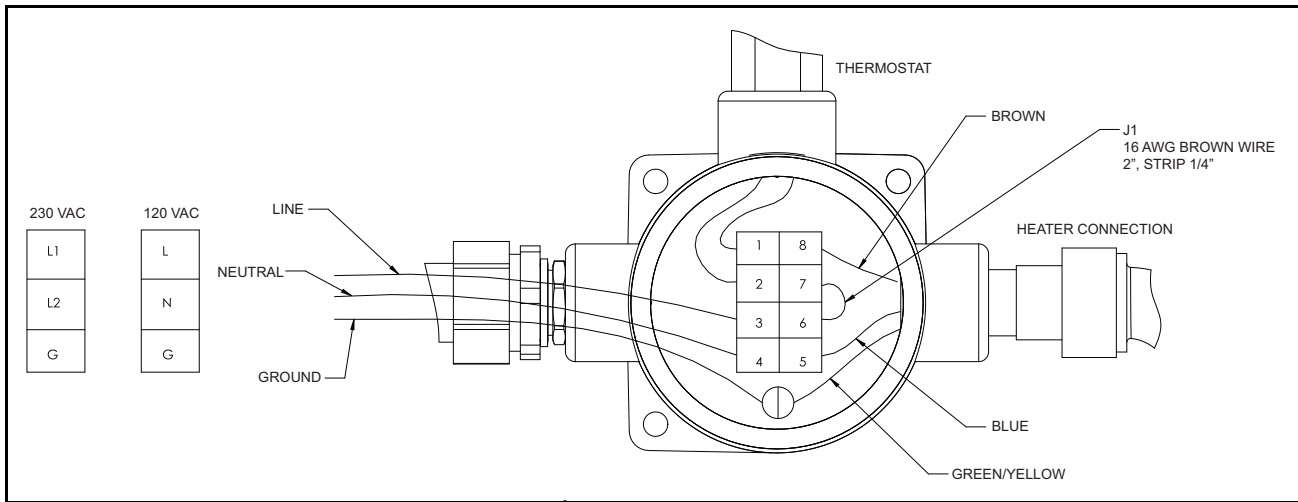

Figure 5: USA/CAN Heater Wiring Diagram

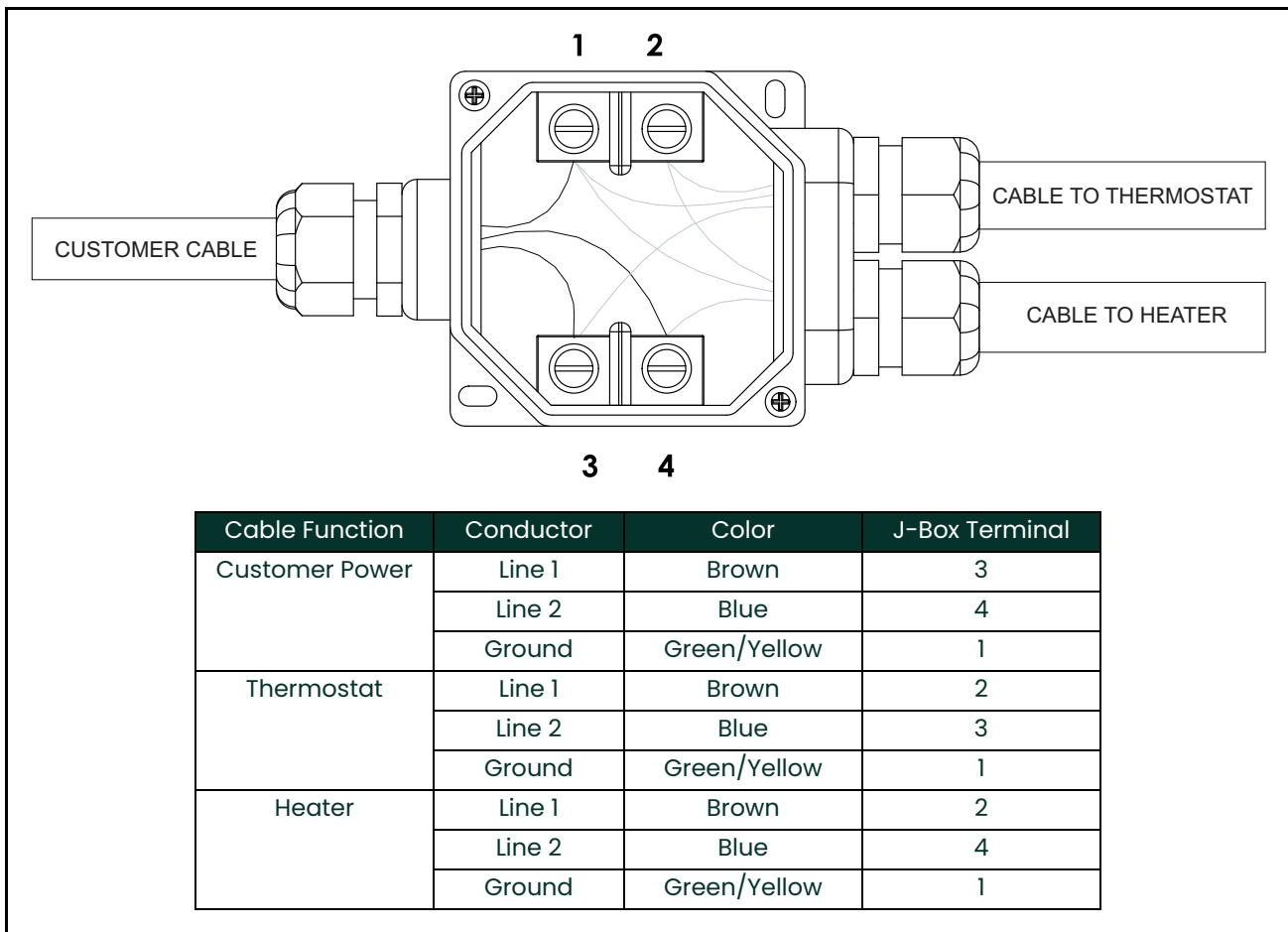

Figure 6: EU/ATEX Heater Wiring Diagram

1.4 Specifications

1.4.1 Range

Range:

0 to 5000 ppm_v; for CO₂ applications: 0 to 1000 ppm_v

Lower Detection Level:

2 ppm_v for CO₂ applications: 20 ppm_v (-55.3°C)

Dew/Frost Point:

-97.1° to 27.3°F (-71.7° to -2.6°C) frost point @ STP of 25°C, 14.696 psia

Process Dew/Frost Point:

Process or equivalent dew point/frost point by calculation with process pressure signal (4-20 mA) or constant

Absolute Humidity:

0.095 to 237 lbs/MMSCF (1.52 to 3,803 mg/m³)

1.4.2 Accuracy

Parts Per Million By Volume:

±1% of reading or ±2 ppm_v, whichever is greater; for >1000 ppm_v ±5% of reading

For CO₂ applications: ±3% of reading or ±5 ppm_v

For H₂ recycle applications: ±1% of reading or ±2 ppm_v (for up to ±5% H₂ and ±1% C₂H₆ variation from nominal calibration composition)

(Individual instrument calibrated accuracy conditions provided in *Certificate of Conformance*. Accuracy of other parameters derived from ppm_v.)

Repeatability:

±0.2 ppm_v or ±0.1%, whichever is greater; for CO₂ applications: ±1.0 ppm_v or ±0.5%, whichever is greater

Calibration Certification:

NIST or equivalent NMI traceable certification

Calibration Options:

Nitrogen, standard natural gas and 3 customizable calibration curves

1.4.3 Response Time

Response Time:

Optical system <2 seconds

System Response:

The system response is dependent on the length of sample tubing, sample system components, flow rate and pressure, as well as the change in moisture concentration.

1.4.4 Pressure

Operating Sample Cell Pressure:

10 to 25 psia (69 to 172 kPa)

Maximum Pressure:

200 psi (1380 kPa)

Process Pressure:

400 psig (2.76 MPa) [2500 psig (17.23 MPa) with heated pressure regulator option]

Note: Higher pressure available with the application of additional sampling system components.

1.4.5 Flow Rate

Sample Cell Flow Rate:

10 to 60 SLH (0.4 to 2 SCFH); 30 SLH (1 SCFH) nominal

By-Pass Fast Loop:

5 to 10X of flow rate through sample cell

1.4.6 Inputs/Outputs

Display:

Backlit LCD; three programmable simultaneous parameters; alphanumeric status and diagnostic display; LEDs for power, laser temperature stability and keypad lockout

Power:

Analyzer: 100-240 VAC, 50-60 Hz, 24VDC

Analog Outputs:

Three 0/4-20 mA DC (source) with 500 ohm load; user programmable for any parameter and scalable; complies with NAMUR protocol for analog signals

Analog Input:

Loop powered 4-20 mA input for remote pressure transmitter; Aurora supplies 24 VDC

Digital Interfaces:

Two programmable digital communications ports: RS232, RS485 with multi-drop capability and assignable address; MODBUS RTU protocol
One Ethernet port: Modbus TCP/IP protocol

User Interface:

Programmable "through-the-glass" via magnetic stylus

Laser:

Class 1 product; Conforms to IEC 60825-1 Edition 2.0 Safety of Laser Products



WARNING! Use of controls or adjustments or the performance of procedures other than those specified herein may result in hazardous laser exposure.

1.4.7 Enclosure

Ingress Protection:

IP-66

Net Weight:

45 kg (100 lb)

Dimensions (H x L x W):

841.2 mm x 461 mm x 332.3 mm (33.12 in. x 18.31 in. x 13.08 in.)

1.4.8 Temperature

Operating:

-20 to 65°C (-4 to 149°F)

Storage:

-20 to 70°C (-4 to 158°F)

Optional Heater/Thermostat Set Point (100-240 VAC option only):

20°C/68°F ±5°C/9°F for US/Canada; 10°C/50°F ±5°C/9°F EU and elsewhere

1.4.9 Hazardous Area Certification

USA/Canada:

Explosion-proof for Class I, Division 1, Groups B, C, D

EU and Elsewhere:

ATEX and IECEx: Ex de IIB+H2 T6 -20°C to +65°C; Flameproof with increased safety compartment

[no content intended for this page]

Chapter 2. Installation

2.1 Introduction

The **Aurora H2O** analyzer provides direct indication of moisture concentration in natural gas. Temperature and pressure sensors are used to provide high precision enhancement. It may be installed in a wide variety of environmental conditions, and meets the requirements for operation in hazardous areas.

Be sure that the ambient temperature is at least 10°C higher than the maximum dew/frost point temperature you expect to measure. This will ensure that you will not have liquid condensation in the sample transport line or the **Aurora H2O** sampling system components. Heat tracing the sample line will aid in elevating the sample temperature above the dew point. An optional heater installed within the enclosure is also available.

2.2 Bill of Materials

The following items should have been received with your shipment:

- **Aurora H2O** Unit
- **Aurora H2O** User's Manual on CD ROM
- **AuroraView** Software on CD ROM
- **Aurora H2O** Calibration Data Sheet
- Maintenance/Accessories Kit
- Optional: Pipeline Insertion Filter/Regulator Assembly

2.3 Unpacking

The **Aurora H2O** is shipped in a packing box with a plywood base (see *Figure 7* below), and the **Aurora H2O** analyzer is secured to the plywood base with mounting bolts. Transport the shipping package with the plywood base on the bottom, and according to the warning labels on the exterior packaging. Open the packing box from the top, and remove the foam packing material. Collect any separate components such as the **AuroraView** CD, the User Manual CD, and other items contained in the shipment.



Figure 7: Unpacking the Aurora H2O

Remove the mounting studs at the bottom of the enclosure. Using two people, lift the **Aurora H2O** from the bottom of the enclosure and from the top of the enclosure where the analyzer electronics is located. A typical **Aurora H2O** weighs approximately 100 pounds (45 kg). Use a proper lifting technique to avoid injury.

Check all the received components and record the model numbers and serial numbers for your records. If anything is missing, contact Panametrics immediately.

2.4 Choosing A Site for Installation

You should have discussed environmental and installation factors with a Panametrics Sales, Application or Service Engineer by the time you receive the analyzer.

Before installing the analyzer, read the guidelines below on installation recommendations:

1. Choose an installation site for the **Aurora H2O** analyzer as close to the actual sample point (sample take-off point) as possible, to minimize transport time to the analyzer.
2. Avoid unnecessarily long lengths of sample transport tubing to minimize transport time to the analyzer.
3. Avoid dead-legs in the sample transport tubing to minimize the possibility of liquid build-up.
4. Use stainless steel tubing. Avoid using copper tubing, as the water molecule has greater absorption capabilities for copper compared to stainless steel. Avoid rubber or plastic tubing at all costs, as water molecules will interact with the tubing, and ambient moisture can permeate through the tube wall into the sample gas.
5. Mount the **Aurora H2O** analyzer at grade, or at a location that is easily accessible for maintenance (on a platform or other structure).
6. Be sure that the ambient temperature is at least 10°C higher than the maximum dew/frost point temperature you expect to measure. This will ensure that you will not have liquid condensation in the sample transport line nor in the **Aurora H2O**. Heat tracing the sample line will aid in elevating the sample temperature above the dew point. An optional heater installed within the enclosure is also available.

A typical **Aurora H2O** system for monitoring moisture off a natural gas pipeline is shown in *Figure 8 on page 15*.

2.4 Choosing A Site for Installation (cont.)

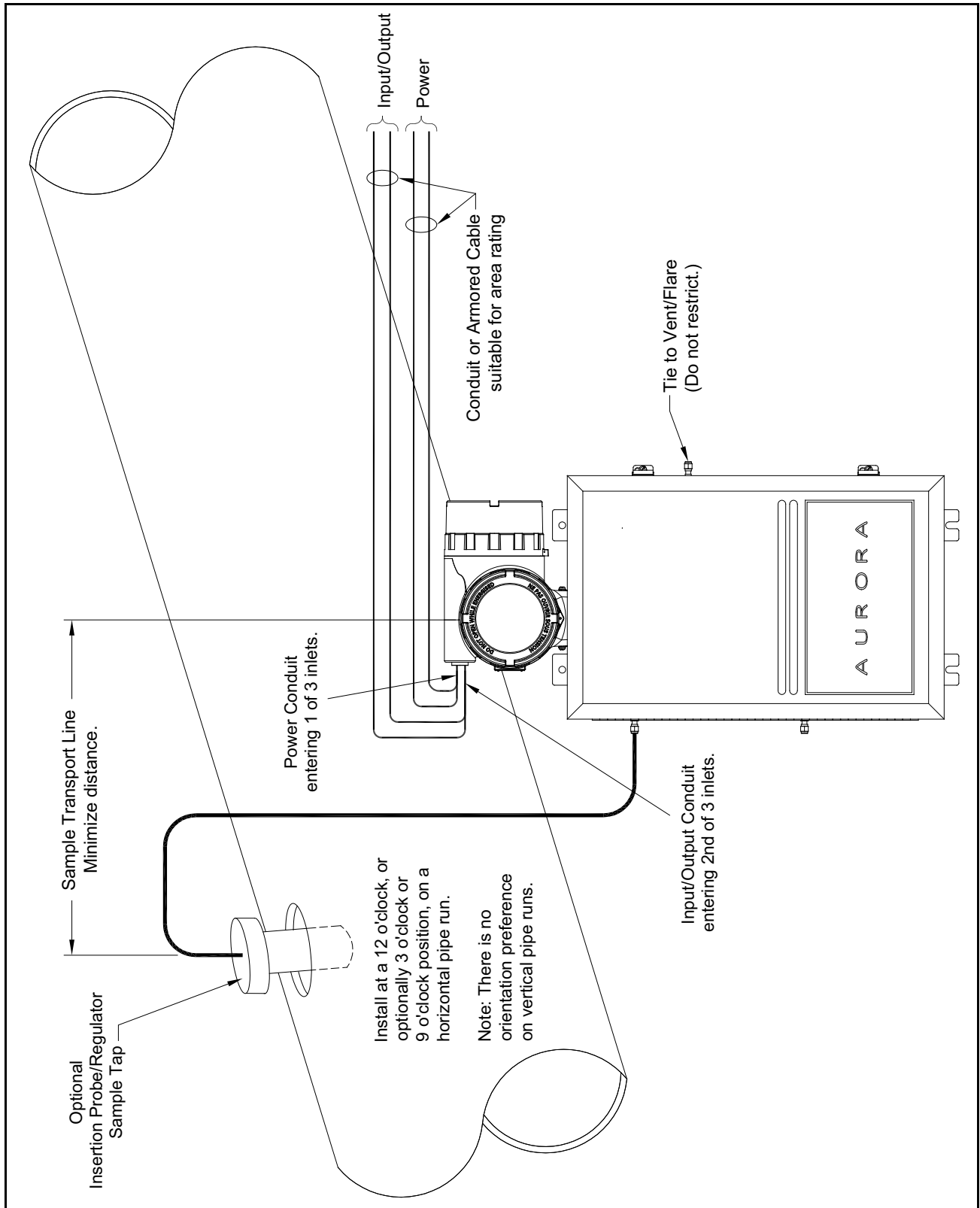

Figure 8: Aurora H₂O Analyzer Monitoring Moisture Content Within a Natural Gas Pipeline

2.5 Low Voltage Directive

To comply with the Low Voltage Directive, you must install a switch or circuit breaker on the input power line. For greatest safety, locate the circuit breaker or power switch near the electronics console.

IMPORTANT: Installation must be done in accordance with the National Electrical Code, the Canadian Electric Code, and/or any other applicable local codes.

2.6 Mounting

Use the four mounting tabs to mount the **Aurora H2O** System Assembly in the desired location (see *Figure 32* on page 31).

IMPORTANT: The **Aurora H2O** should only be mounted vertically.

2.7 Optional Insertion Probe/Regulator

2.7.1 Description

For natural gas applications that may have entrained particulate and liquid contaminants (especially TEG carry-over from TEG dryers), Panametrics recommends the use of a *Insertion Probe/Regulator* (see *Figure 9* below) to serve as the first part of particulate and condensate filtration where the gas is sampled off the pipe. The device combines the features of a sample tap, a membrane filter and an integral pressure regulator (0–500psig outlet), adjustable at the sample take-off point. The sample tap housing includes a foot-valve so that, once installed, the assembly can be removed from a line under pressure for membrane filter replacement as needed.

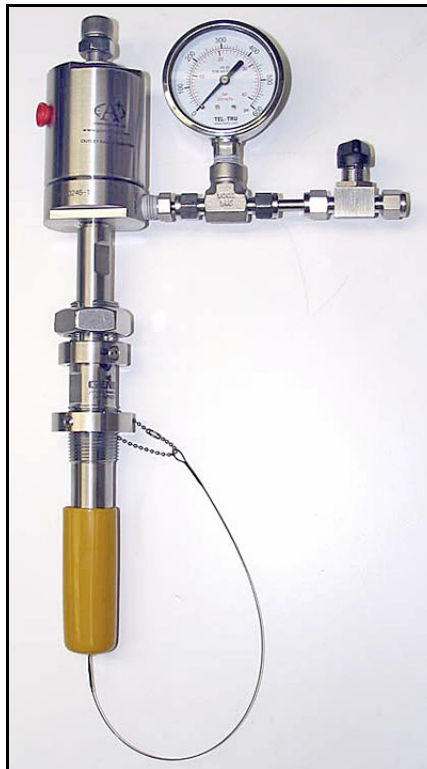

Figure 9: Insertion Probe/Regulator

Note: A 29/32" (0.907 inch, 23.1 mm) minimum bore-through clearance is needed on the customer nozzle for insertion of a 3/4" NPT insertion membrane liquid separator/pressure regulator.

2.7.2 Installation

Note that the *Optional Insertion Probe/Regulator* can be installed only on unpressurized lines. There is no hot-tap installation for this device.

This procedure is broken down into two steps:

- Installing the Housing
- Installing the Insertion Probe/Regulator Assembly

2.7.2.1 Installing the Housing

The housing, as shown in *Figure 10* below, is supplied with a *Locking Mechanism* to ensure that housing can only be removed intentionally.

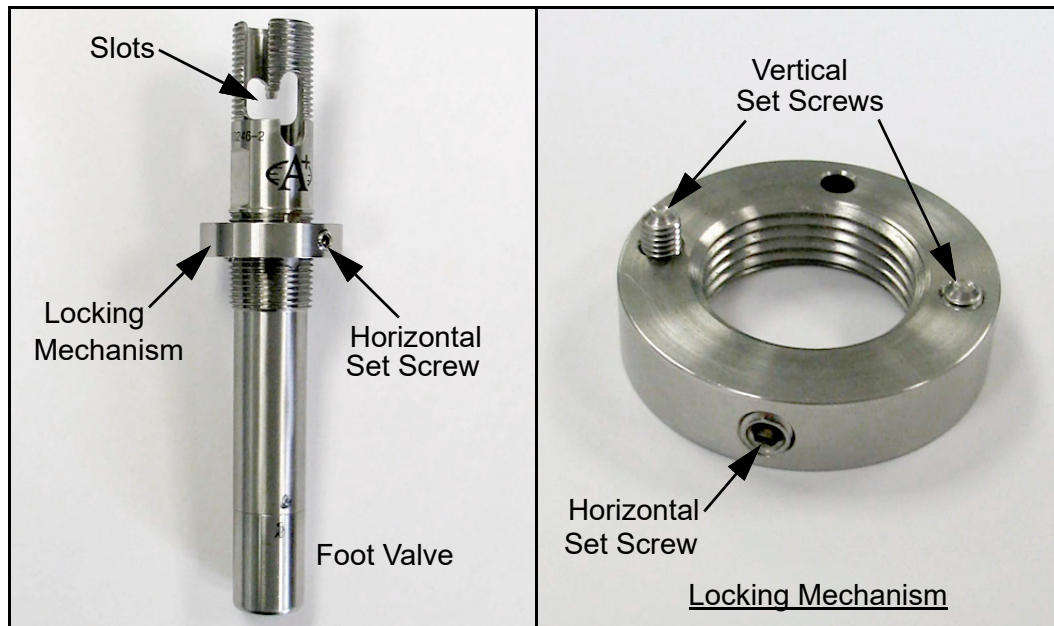

Figure 10: Installing the Housing and Locking Mechanism

1. Turn the locking mechanism counter-clockwise until it is at its extreme upper position. Apply thread sealant to the threaded area below vertical slots in the threads (see *Figure 11* below). Do not allow the thread sealant to enter the slot, as it may interfere with the mechanism.

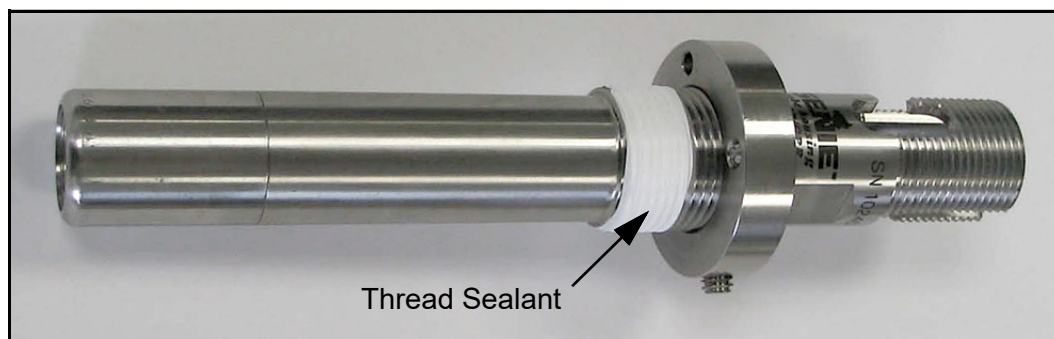

Figure 11: Applying Thread Sealant

2.7.2.1 Installing the Housing (cont.)

2. Confirm that the pipeline has been unpressurized. Refer to *Figure 12* below and insert the housing into the pipeline through a $\frac{3}{4}$ " NPTF thread-o-let (The minimum ID of the thread-o-let is 0.91").

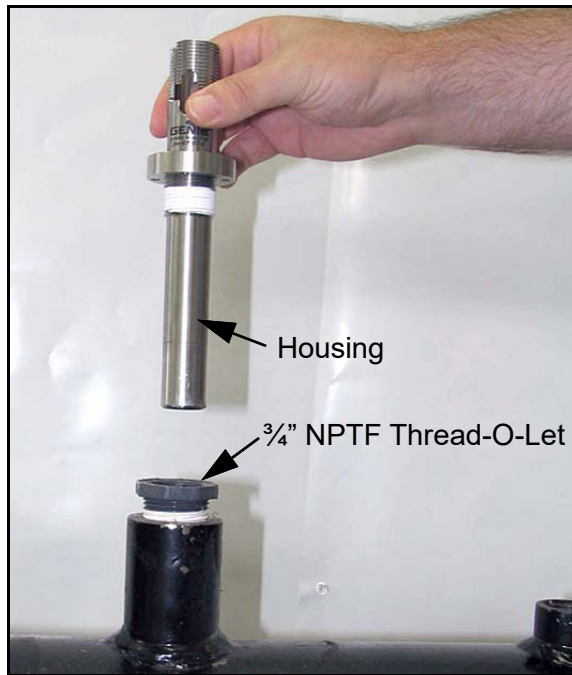

Figure 12: Inserting Housing into Pipeline

3. Using a wrench on the wrench flats, turn the housing until it is secure and sealed (see *Figure 13* below). This will require between three and five turns. **DO NOT OVERTIGHTEN!** The housing may be damaged if it is over-tightened, causing the housing to deform.

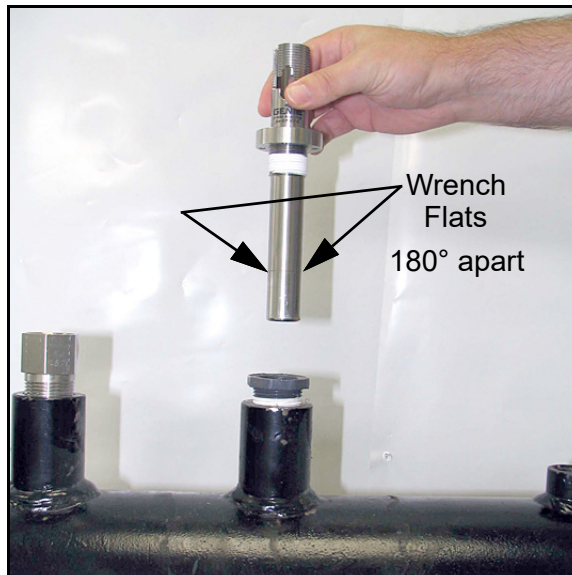

Figure 13: Tightening the Housing

2.7.2.1 Installing the Housing (cont.)

4. Turn the locking mechanism clockwise until it first touches the top of the thread-o-let.
5. Turn the locking mechanism counterclockwise until the Allen screw is aligned with the thread slot (see *Figure 14* below). Using a 1/8" Allen wrench, tighten the Allen screw until its tip is tight against the slot. **DO NOT OVERTIGHTEN THE ALLEN SCREW** as this will cause the housing wall to be indented.



Figure 14: Aligning and Tightening the Allen Screw

6. Using a 3/32" Allen wrench, tighten the Allen screws on the locking mechanism's surface until their tips are firmly set into the thread-o-let's upper surface (see *Figure 15* below).



Figure 15: Tightening the Allen Screws

The housing is now installed. The locking mechanism should prevent the housing from becoming unintentionally unscrewed from the thread-o-let. The pipeline may now be pressurized.

2.7.2.2 Installing the Insertion Membrane Liquid Separator/Pressure Regulator Assembly

1. Confirm that the Allen cap screw head's hex cavity is clean and free from foreign material. Confirm that the Allen cap screw that holds the membrane ferrule is torque-wrench tight (see *Figure 16* below). The torque value should be 10 inch-lbs. If the Allen cap screw is only hand-tight, the screw may protrude excessively, which could result in foot valve actuation when the probe is installed into the housing.

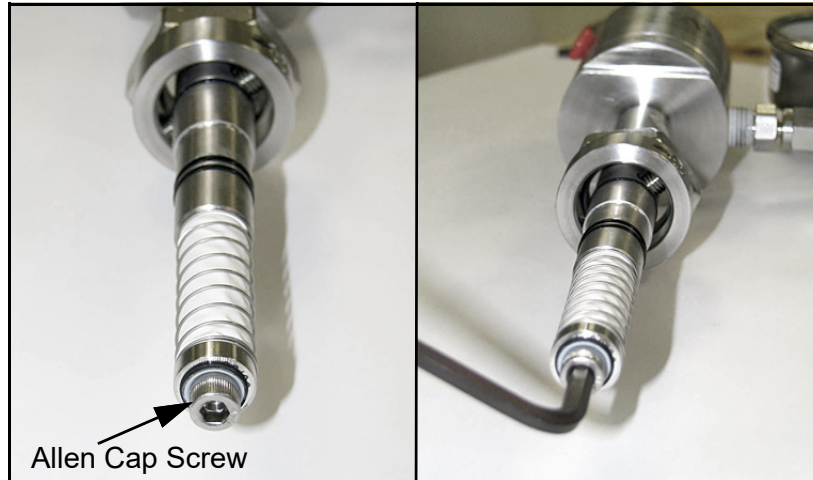

Figure 16: Checking/Tightening the Allen Cap Screw

2. Rotate the pressure adjustment screw on the pressure regulator fully counterclockwise until it rotates freely. Close the isolation ball valve (see Figure 17 below).

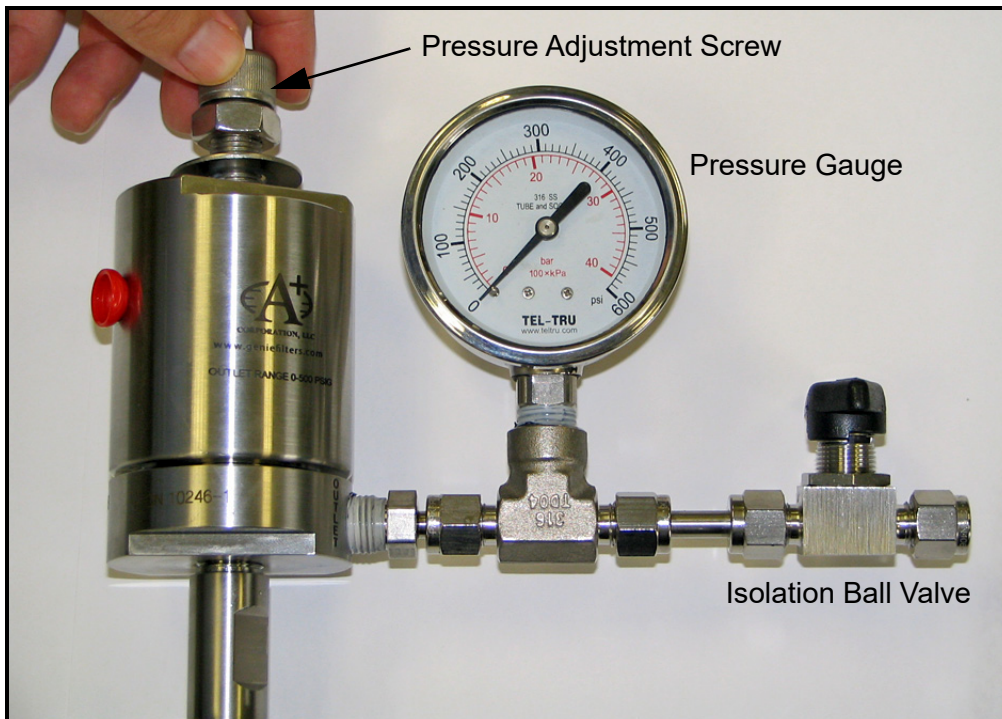

Figure 17: Rotating the Pressure Adjustment Screw

2.7.2.2 Installing the Insertion Membrane Liquid Separator/Pressure Regulator Assembly (cont.)

- Refer to *Figure 18* below and position the membrane end of the probe above the installed housing. Slowly lower the probe into the housing. Avoid membrane contact with the upper section of the housing. **DO NOT APPLY DOWNWARD FORCE.** The probe should slide easily into the housing. Lower the probe only enough to thread the insertion nut one complete turn of thread engagement.

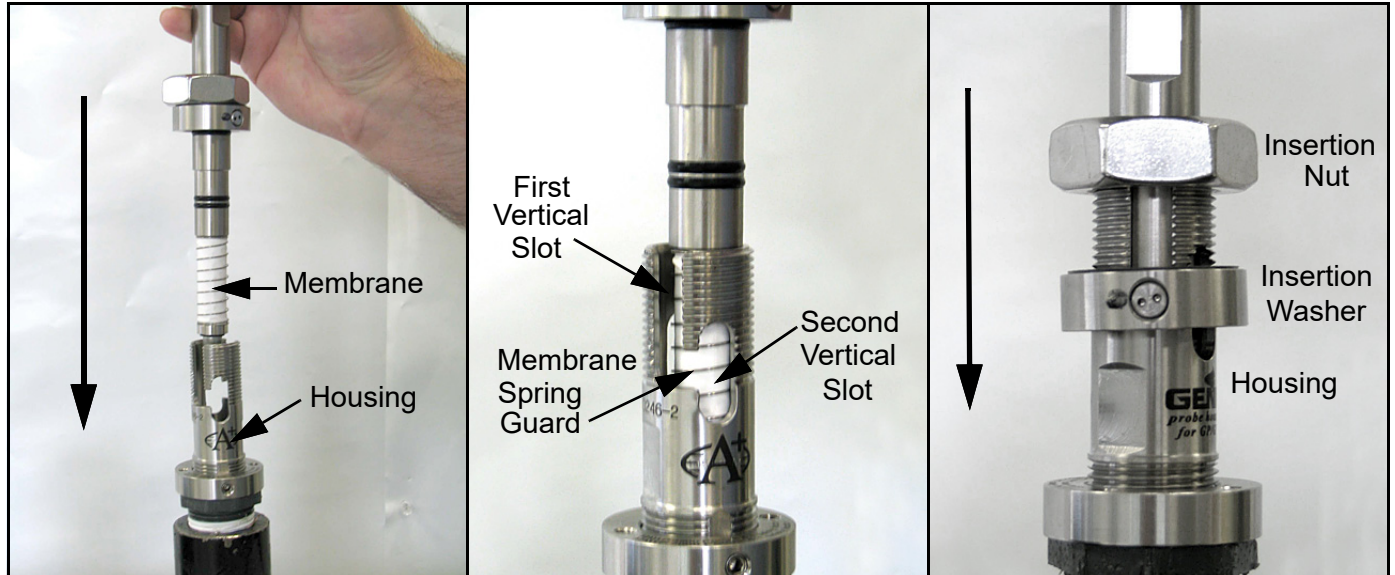

Figure 18: Installing the Probe

- Thread the insertion nut down by hand, lowering the probe until the insertion washer pins slide to the bottom of the first vertical slot (see *Figure 19* below).

Note: The threaded nut on the housing ensures that if all other safety procedures are disregarded, it is mechanically impossible to remove the probe.

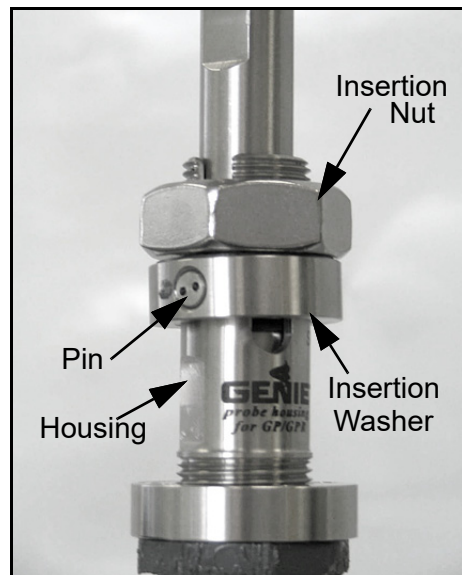

Figure 19: Threading the Insertion Nut

2.7.2.2 Installing the Insertion Membrane Liquid Separator/Pressure Regulator Assembly (cont.)

5. Rotate the probe counterclockwise until the pins are to the far right in the horizontal slot. At this point, the probe is sealed against the housing interior wall. The pins will be in the middle of the second vertical slot (see Figure 20 below).



Figure 20: Rotating the Probe

6. Loosen the insertion nut until it is above the top of the second vertical slot (see Figure 21 below). The probe should not rise to the top of the second vertical slot. If the probe rises in the slot, the foot valve o-ring may have been damaged or attacked by the process.

Note: *The threaded nut on the housing ensures that if all other safety procedures are disregarded, it is mechanically impossible to remove the probe. Perform the next step regardless of the status of the foot valve o-ring.*



Figure 21: Loosening the Insertion Nut

2.7.2.2 Installing the Insertion Membrane Liquid Separator/Pressure Regulator Assembly (cont.)

7. Tighten the insertion nut by hand until it is against the insertion washer again. Using a wrench, tighten the insertion nut against the insertion washer so that the pins are at the bottom the second vertical slot (see *Figure 22* below). At this point the foot valve opens and the insertion process is complete.



Figure 22: Tightening the Insertion Nut

2.7.3 Setting the Pressure

Note: Perform these steps only after the entire system has been plumbed, including the **Aurora H2O**.

1. Ensure the inlet sample gas isolation valve on the **Aurora H2O** sample system is closed. Open the isolation ball valve at the *Optional Pipeline Insertion Membrane Liquid Separator/Pressure Regulator*.
2. Turn the pressure adjustment screw clockwise to increase the pressure (see *Figure 23* below). The optional pipeline insertion membrane liquid separator/pressure regulator is the FIRST STAGE pressure reduction of the system when used. Depending upon your source pressure, you should step down the pressure to a value in the range listed in *Table 2* below.
3. Tighten the lock nut down to the top of the pressure regulator to avoid future possible changes in pressure regulator setting, once the pressure is set.

Table 2: Pressure Settings

Source Pressure	Outlet Pressure Setting
750 psig < source < 1500 psig	400-500 psig
500 psig < source < 750 psig	300 psig
< 500 psig	50% of the average source pressure

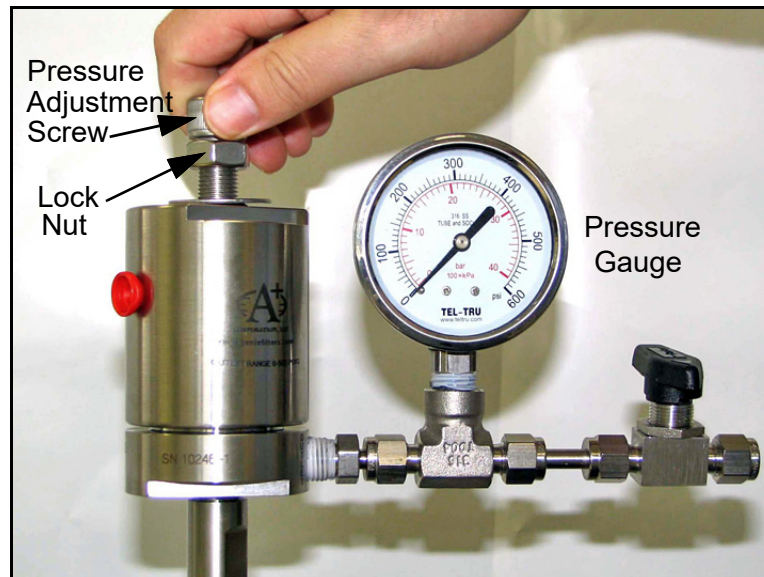

Figure 23: Turning the Pressure Adjustment Screw

2.8 Making Electrical Connections

Refer to *Figure 33* on page 32 for wiring connections.

1. **Aurora H2O** has three $\frac{3}{4}$ " NPT conduit inlet ports for power and I/O (see *Figure 24* below). These will normally be shipped plugged from the factory. Follow the applicable wiring code and requirements for wiring the unit.

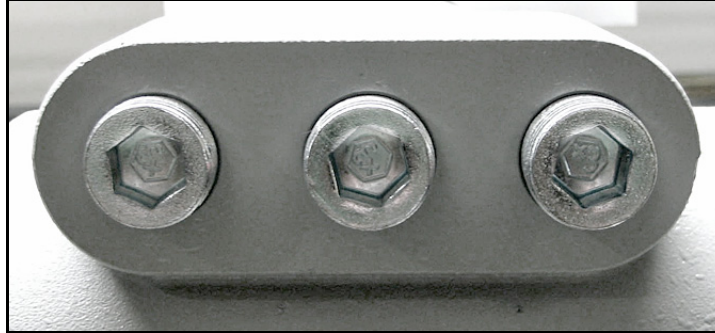

Figure 24: Conduit Inlet Ports

Note: Use one conduit inlet for power. Use the two other conduit inlets for input/output as needed. All unused conduit inlet ports should be sealed with suitable blanking elements.

2. Select one conduit for inlet power to the **Aurora H2O** based on your configuration. The **Aurora H2O** comes with a universal power supply, or optionally, as a 24VDC powered unit. Remove the wiring cover to view the wiring terminal block (see *Figure 25* below).



Figure 25: Wiring Terminal Blocks

2.8 Making Electrical Connections (cont.)

Note: Supply connection wiring shall be rated at least 10°C above the rate maximum service temperature of 85°C, be stripped back 5/16 in. (8 mm) and torqued to a minimum of 4.4 in. lb. (0.5 Nm).

3. Run the AC power connections to the Power Terminal Block shown in *Figure 26* below. It is recommended to use 12-18 AWG (3.3 – 0.82 mm²) power wiring.



Figure 26: Power Terminal Block

4. Use wiring conduit runs, separate from the **Aurora H2O** main power, for all I/O (Input/Output) leads. Wire up to three 4-20mA outputs to the terminals labeled A, B, and C. The three analog outputs A, B and C (0-20mA or 4-20mA) are internally powered by the **Aurora H2O**. Use shielded 18-22 AWG (0.82-0.33 mm²) twisted pair wire, and ground the shield at one end only. Wire up digital communications to Port 1 and/or Port 2 as labeled.
5. Either digital port may be configured for RS-232 or RS-485. Port 1 is designated as "SCADA." Port 2 is designated as "SERVICE." For operation on RS-485, 2-wire, half-duplex bus, attach the RS-485(+) to (+), and the RS-485(-) to (-). Per Modbus-IDA specifications, a third, common conductor must also interconnect all the devices of the bus. Attach the common conductor to RTN.

Note: For an RS-485 Multi-drop Network, a terminating resistor must be installed across the **Aurora H2O** RS-485 terminals, or an internal terminating resistor can be applied. See below.

- When using the **Aurora H2O** in RS-485 mode, and to prevent signal reflections on the high-speed RS-485 connections, it is recommended that the far end of the RS-485 lines be terminated properly. The termination can be accomplished in one of two ways:
 - Connect 120 Ω, 1/4 W leaded resistors across the + and – terminals of ports 1 and 2 (both ports or whichever one will be in use)
 - Using long-nose pliers, move jumpers J15 and J16 from pins 2 and 3 (default setting from factory) to pins 1 and 2 (see *Figure 27* on page 27). J16 is the termination for port 1 and J15 is the termination for port 2. It is also recommended that basic ESD precautions such as grounded wrist straps be used for this procedure.

2.8 Making Electrical Connections (cont.)

Multi-drop RS-485:

For multiple **Aurora H2O** units connected in daisy-chain fashion to the RS485 interface, it is important that the farthest unit away from the transmitting device be the only unit incorporating any termination (see *Figure 27* below). All other units must have jumpers J15 and J16 in positions 2 & 3 (default setting from the factory). For more details on RS-485 wiring or operation, refer to TIA/EIA-485-A Specification.

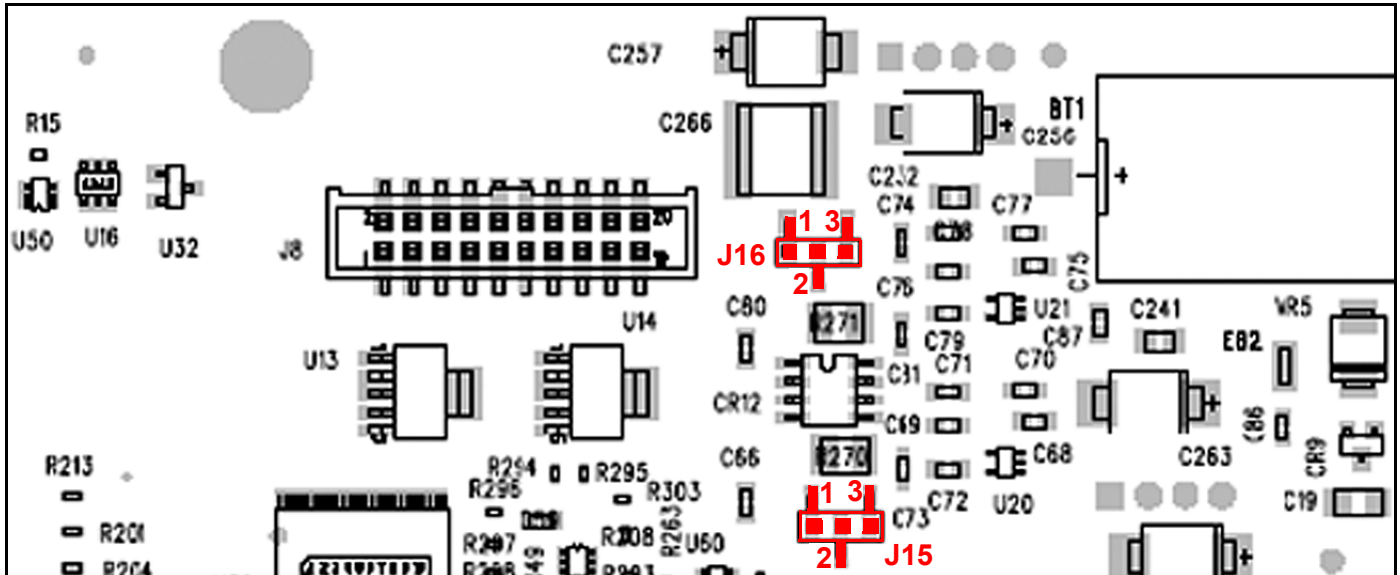

Figure 27: RS-485 Mode Termination - Install Jumpers at J15 and J16, Pins 1 and 2

Note: The internal terminations **MUST** be in the default (unterminated) position for operation in RS-232 mode.

- For operation on RS-232, connect RS-232(TXD) to (+), RS-232(RXD) to (-), and RS-232(GND) to RTN (see *Figure 28* below).

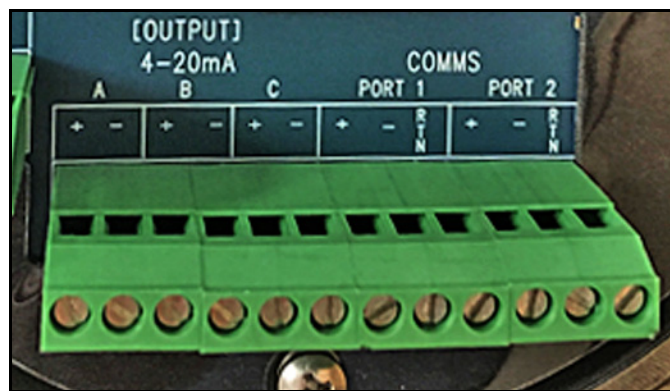

Figure 28: Input/Output Connections

2.8 Making Electrical Connections (cont.)

6. Prepare a shielded CAT5e Ethernet cable with flying leads compatible with the TIA/EIA-568 specification. For proper operation, Aurora H2O requires connection of the TX and RX pairs, as well as the shield wire. Connect the leads per *Figure 29* and the table below, depending on the cable used:

Lead Color	TIA/EIA 568A	TIA/EIA 568B
White/Green	TX+	RX+
Green	TX-	RX-
White/Orange	RX+	TX+
Orange	RX-	TX-



Figure 29: Ethernet Terminal Block

7. For connection to a PC to interface with **AuroraView** software, you may use the supplied 704-668 cable (RS-232 w/ SUB-D-9 connector to tinned leads). Wire the cable as follows:

Lead Color	Function	Aurora H2O Terminal
White	TX	+
Red	RX	-
Green	Ground	RTN

The as-shipped default configuration is as follows:

BAUD Rate:	115, 200
Parity:	Even
Network ID:	1 for Port 1, 2 for Port 2

2.8 Making Electrical Connections (cont.)

8. Use a separate wiring conduit run for any 4-20mA pressure transmitter input. This input is used when a live input pressure reading for the main process pressure is desired, to determine an equivalent dew point by the **Aurora H2O** analyzer. Wire the 4-20mA pressure transmitter to the Pressure Transmitter terminal block (see *Figure 30* below). The **Aurora H2O** supplies 24VDC for use with a loop-powered, 2-wire pressure transmitter.

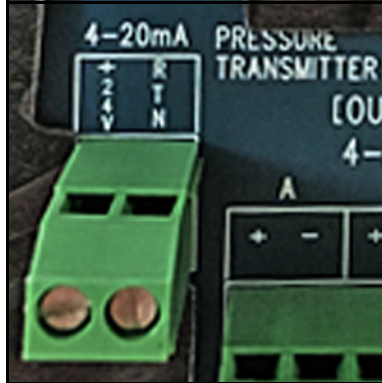

Figure 30: Pressure Transmitter Connections

IMPORTANT: Use of an external pressure transmitter is not covered by the **Aurora H2O** hazardous area certifications. The external pressure transmitter should be suitably rated for the area classification. Its associated wiring should be done in accordance with local codes and regulations, and suitably rated for the area classification.

9. If the **Aurora H2O** has been supplied with an optional electrical heater, there are two possible configurations: USA/CAN or EU. Connect the AC power using a separate conduit from the power for the **Aurora H2O** analyzer. The heater is equipped with a thermostat preset to 25°C (77°F) nominal. Use 12-18 AWG (3.3 - 0.82 mm²) wires. The heater terminals are located within a junction box (item 15 in *Figure 2 on page 4* or *Figure 3 on page 5*).
10. Lastly, the **Aurora H2O** analyzer requires a connection to ground from the electronics explosion-proof/flame-proof enclosure. As shown in *Figure 31* below, there are two external ground connections available for the user (on the left and right hand sides of the enclosure). Wire this connection to earth ground, local to the **Aurora H2O** analyzer installation site.



Figure 31: Earth Ground Connection

2.9 Specific Conditions of Use

Before operating your Aurora system, be sure the following conditions are met:

1. In the event of repair or replacement of any components, the manufacturer, Panametrics, shall be contacted for information on the controlled materials and dimensions of the flameproof characteristics of the Aurora H2O Moisture Analyzer.
2. The laser head assembly of the Aurora H2O Moisture Analyzer shall be inside a tool secured enclosure with IP20 or better to ensure the factory installed laser head assembly bolts are inaccessible from the outside.
3. Consult the manufacturer for genuine replacement flange fasteners. 5/16 inch-24 x 1-1/4 inch 18-8 stainless steel socket head cap bolts or better with a minimum tensile strength of 70,000 psi are acceptable alternatives.
4. To reduce the potential of an electrostatic charging hazard, do not rub painted aluminum parts with a dry cloth.

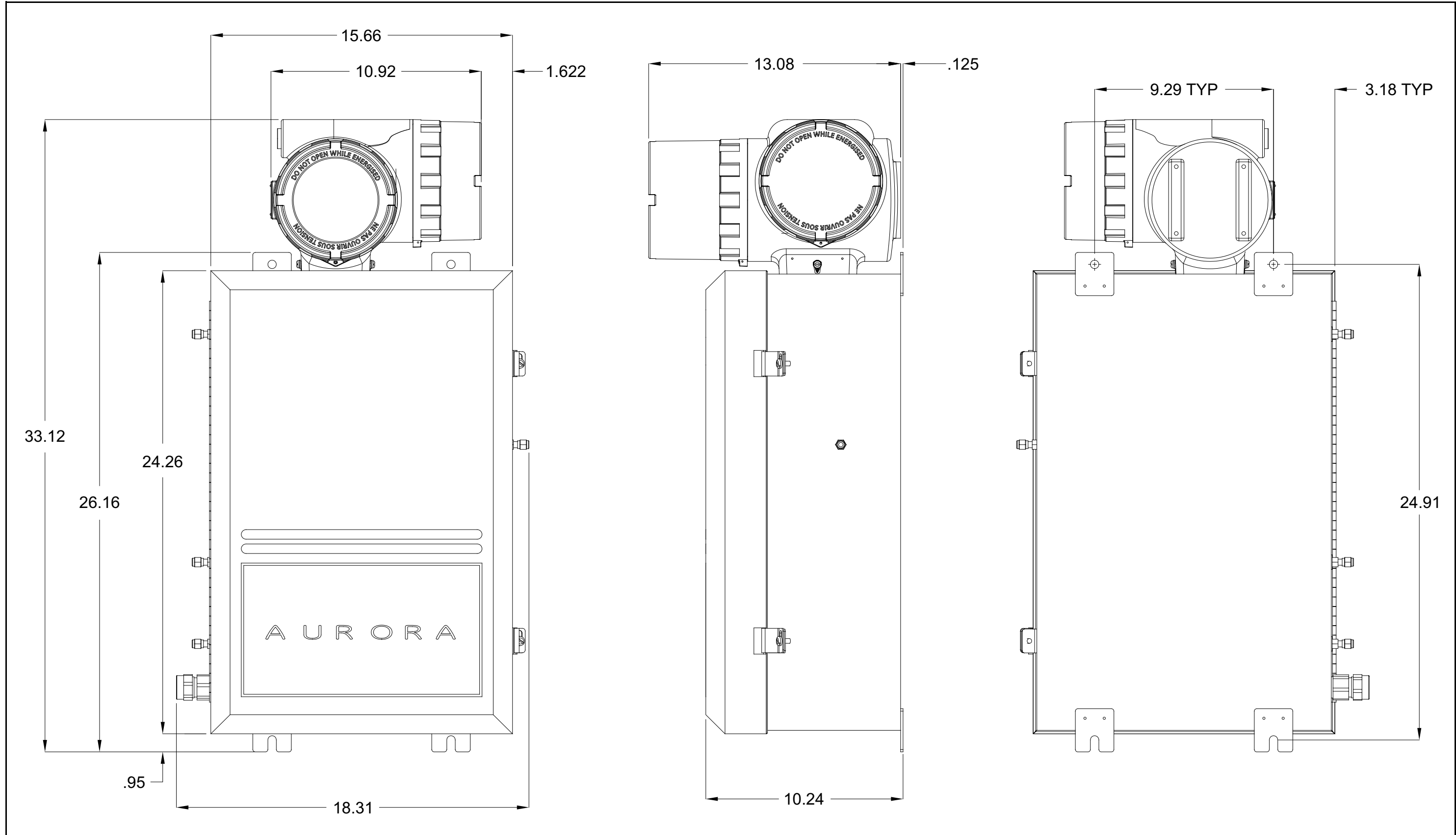
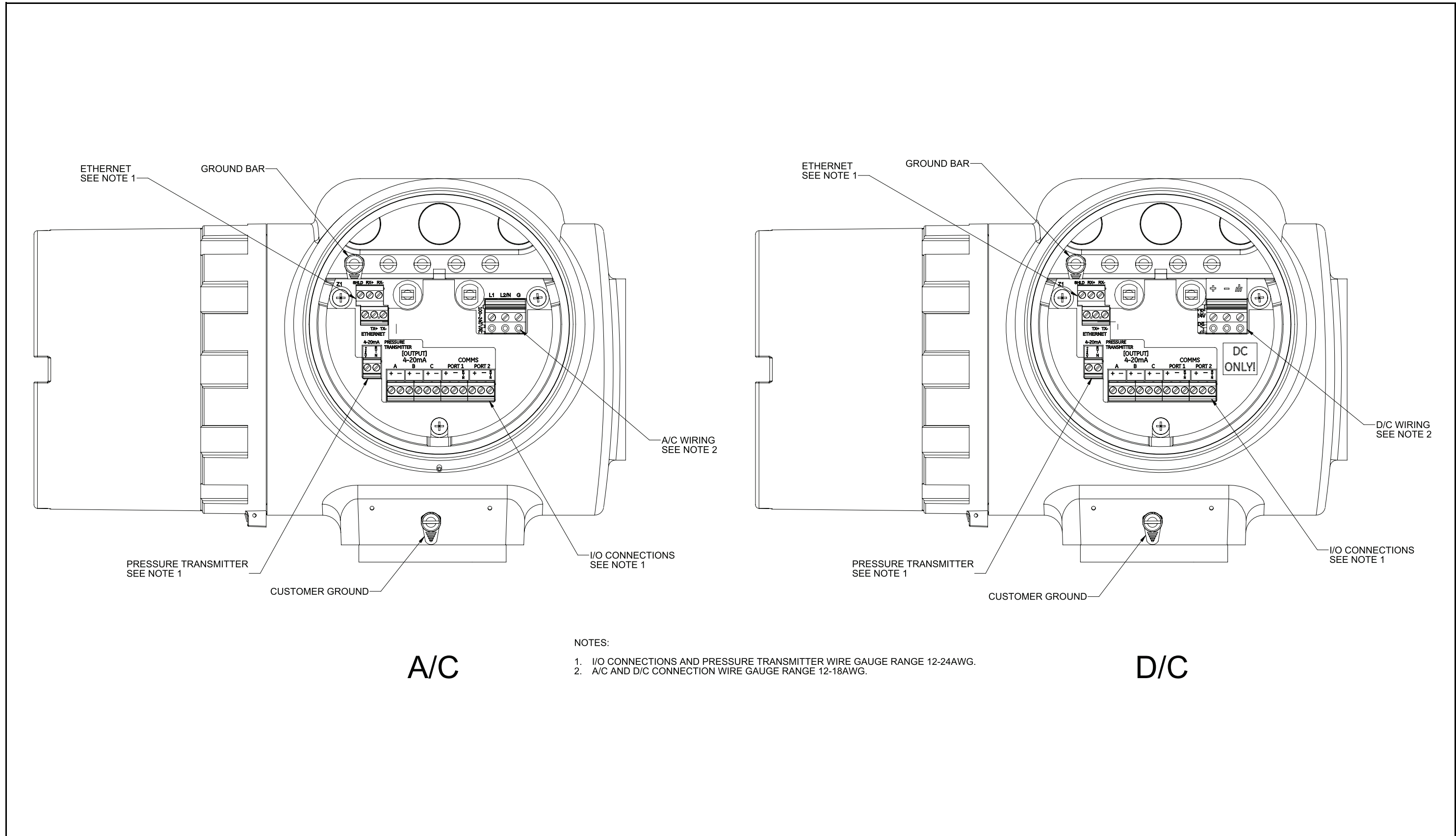

Figure 32: Aurora H2O Outline and Mounting (ref. dwg #712-1456)



A/C

D/C

- NOTES:
1. I/O CONNECTIONS AND PRESSURE TRANSMITTER WIRE GAUGE RANGE 12-24AWG.
 2. A/C AND D/C CONNECTION WIRE GAUGE RANGE 12-18AWG.

Figure 33: Aurora H2O Electronic Assembly Wiring Diagram (ref. dwg #702-8976)

Chapter 3. Operation and General Programming

3.1 Using the Aurora H2O

Follow the information in this chapter to operate the **Aurora H2O** system.

CLASS I LASER PRODUCT



WARNING! Use of controls or adjustments or performance of procedures other than those specified herein may result in hazardous laser exposure.

3.2 Sample System

See the instructions below and *Figure 34 on page 35* to operate the **Aurora H2O** sample system.

3.2.1 Aurora H2O Startup

1. Supply gas *inlet pressure* should be <400 psig (2758 kPa).
2. Confirm that there are no flow restrictions downstream of the analyzer sample outlet. The maximum *outlet back pressure* should be <10 psig (69 kPa).
3. Start with all *needle valves* (items 2, 3 and 4) in the closed position, by turning them fully clockwise. The *pressure regulator* (item 6) should be turned fully counter-clockwise.
4. Start with the *sample gas selector valve* (item 1) handle indicator pointing fully to the right, in order to select the sample gas line.
5. Open the *bypass gas metering valve* (item 2) 1/4 turn counter-clockwise.
6. Fully open the *sample gas metering valve* (item 3) by turning it fully counter-clockwise.
7. Slowly open the supply gas isolation valve (item 4) 1/4 turn counter-clockwise.
8. Slowly turn the *supply gas pressure regulator* (item 6) clockwise until the *sample gas flow meter* (item 7) indicates mid-scale.
 - a. If the pressure is increased too rapidly, it will activate the liquid-block feature of the *membrane filter* (item 8), shutting off the gas flow.
 - b. If this occurs, fully close the *supply gas isolation valve* (item 4) by turning it clockwise.
 - c. Wait 30 seconds and then go back to Step 7 (a pop sound can be heard when the liquid-block opens to allow gas flow).
9. Slowly adjust the bypass gas metering valve (item 2) until the desired flow rate is reached (requires optional flow meter for precise metering).
10. Fully open the *supply gas isolation needle valve* (item 4) by turning it counter-clockwise.

3.2.2 Aurora H2O Shut Down

1. Fully close the *supply gas isolation valve* (item 4) by turning it clockwise.
2. Turn the *supply gas pressure regulator* (item 6) fully counter-clockwise.
3. Fully close the *bypass and sample gas metering valves* (Items 2 and 3) by turning them clockwise.

3.2.3 Service Gas Connection

1. Start with all *needle valves* (items 2, 3 and 4) in the closed position, by turning them fully clockwise. The *pressure regulator* (item 6) should be turned fully counter-clockwise.
2. Confirm that there are no flow restrictions downstream of the analyzer sample outlet. The maximum *outlet back pressure* should be <10 psig (69 kPa).
3. Start with the *sample gas selector valve* (item 1) handle indicator pointing fully to the left, in order to select the service gas line.
4. Connect the regulated and filtered *service gas supply*, as follows.
 - a. Regulated pressure range: 0-10 psig (0-69 kPa)
 - b. Outlet filter size: 7 micron
 - c. Initial pressure setting: 0 psig (minimum)
5. Fully open the *sample gas metering valve* (item 3) by turning it full counter-clockwise.
6. Increase the regulated pressure until the *sample gas flow meter* (item 7) indicates mid-scale.

3.2 Sample System (cont.)

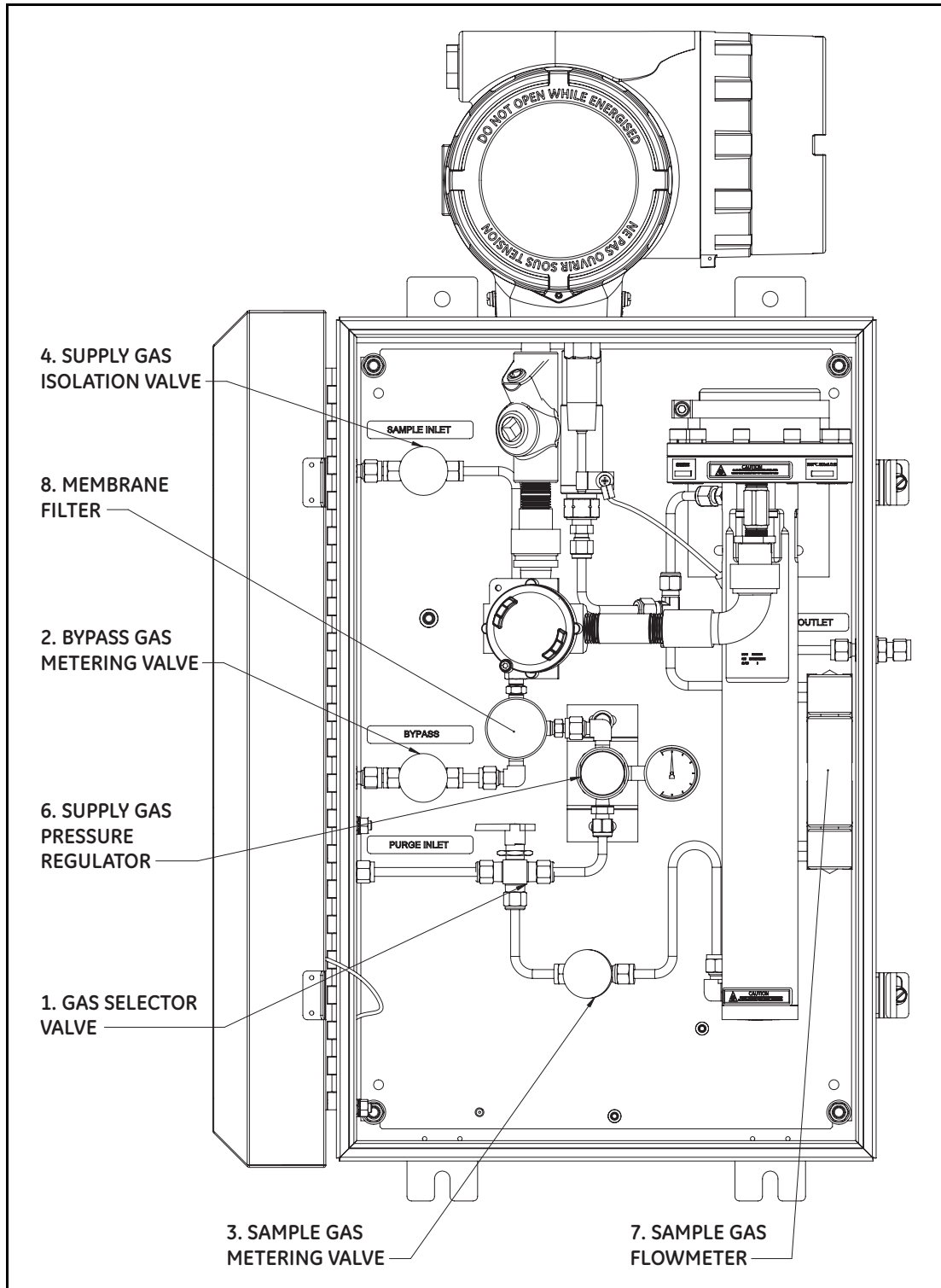
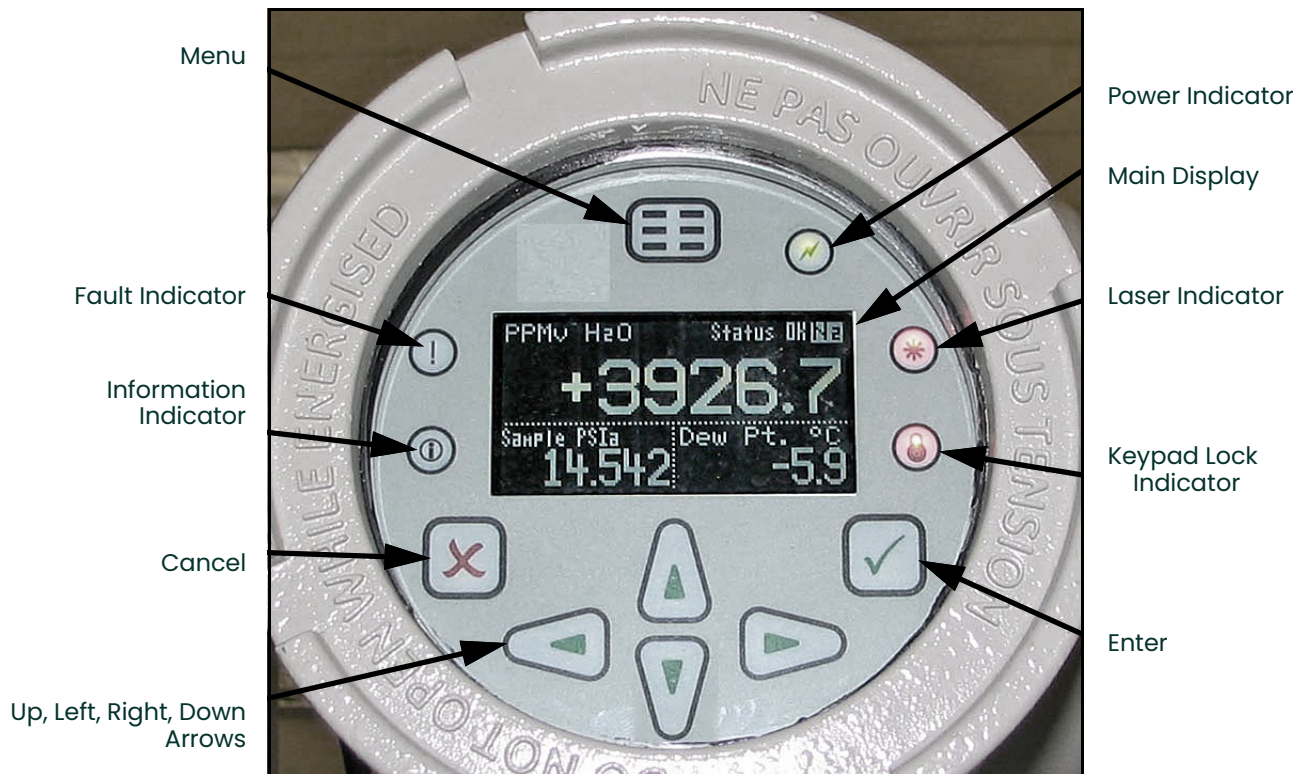

Figure 34: Aurora H2O Sample System (ref. dwg #902-004_revE)

3.3 Keypad Features



The **Aurora H2O** has seven keys: a **Menu** key, four **Arrow** keys, a **Cancel** **X** key, and an **Enter** **✓** key.

- Use the **Menu** key to open the main menu on the display.
- Use the **Arrow** keys to navigate among menu choices and to increment/decrement numeric entries.
- Use the **Cancel** **X** key to cancel a numeric entry change, or exit a menu.
- Use the **Enter** **✓** key to accept a numeric entry or select a menu option.

3.3.1 Indicator Lights

If the **Fault Indicator** is lit, an instrument fault is detected. A message will be displayed in the Main Display, top/right.

If the **Information Indicator** is lit, the instrument is still operating, but a message will appear in the Main Display top/right, with information about the instrument.

The **Keypad Lock Indicator** will be lit if either: A) the Keypad Lock-Out Switch, internal to the instrument, has been engaged, or B) the instrument keypad has not been used for a period of several minutes, engaging a software feature to lock-out inadvertent key usage. Type (B) keypad lock-out is overcome by pressing Cancel, Enter, Cancel in sequence.

If the **Laser Indicator** is lit, the laser is powered and operating normally. This indicator will be off if there is a laser-specific fault. This indicator will also be off for a brief period when the instrument is first powered. After initial power-up, this indicator may blink several times as the laser temperature is stabilized. The laser indicator will be lit constantly in normal operation.

The **Power Indicator** is normally lit when the instrument is powered on.

3.3.2 The Magnetic Stylus

Each of the keys can be selected using a hand-held magnet called a *Magnetic Stylus* (see *Figure 36* below), which is included with the meter. By touching the clear window at a key location, that key will be selected and will flash a red light to verify the contact.

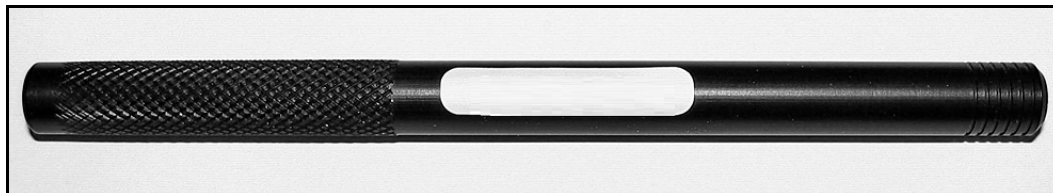

Figure 36: Magnetic Stylus

3.3.3 The Default Display

Figure 37 below shows the default display of the **Aurora H2O** window.

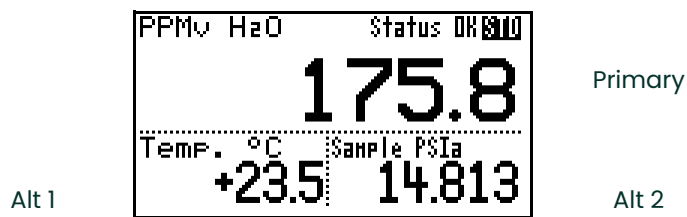

Figure 37: Default Display

3.3.4 Unlocking the Keypad

After power-on, the **Aurora H2O** keypad is locked as indicated by the symbol , lit up with a red backlight. It is necessary to enter the keypad unlock sequence to make any changes to the **Aurora H2O**.

Similar to a mobile phone, the **Aurora H2O** will prompt the operator to unlock if any key is pressed. A passcode is required to use certain factory service features only.

To unlock the keypad, press **Cancel** , **Enter** , **Cancel**  in sequence.

3.3.5 Keypad Lock-Out Switch

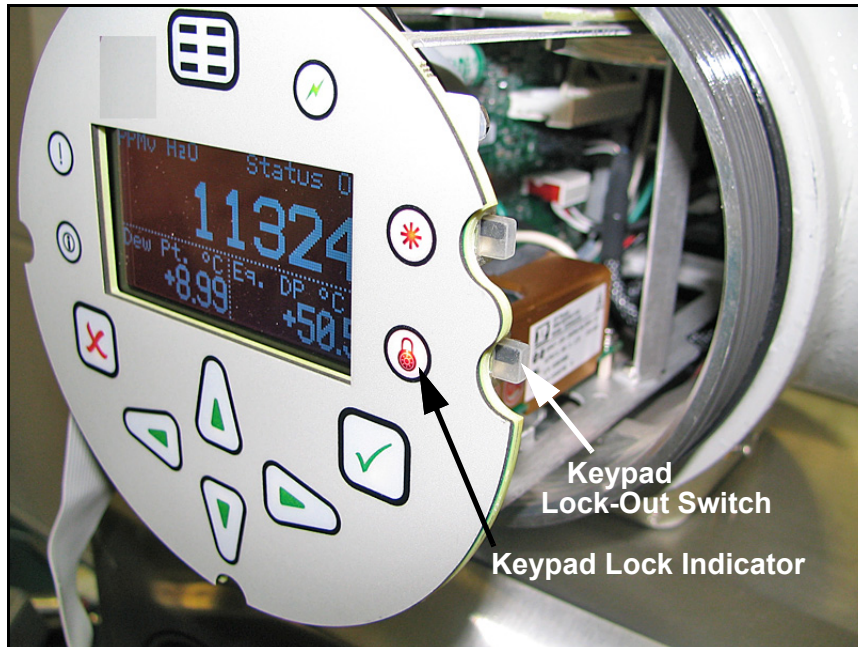

Figure 38: Keypad Lock-Out Switch Location

Note: If the Keypad Lock-Out Switch is in the “down” position, the keypad is locked out and the **RED** LED on the Keypad Lock Indicator is on all the time.



WARNING! Do not open or remove the cover with the power on, unless the area is non-hazardous.

3.3.6 Accessing the Menu

After successfully unlocking the keypad, press the  Menu key. The **Aurora H2O** will display the Main Menu (see *Figure 39* below). Use the arrow keys to highlight the menu item desired. Refer to *Menu Map, Figure 49* on page 75.

Press **Enter**  to select the highlighted item. Many menu items will display another menu. Use **Cancel**  to return to the previous menu page. Pressing **Cancel**  from the Main Menu will return the screen to the **Measurement Display**.

Note: *Menu items displayed with an ellipsis (shown as a series of three dots after the menu item) will bring up more choices, while those without take immediate action.*

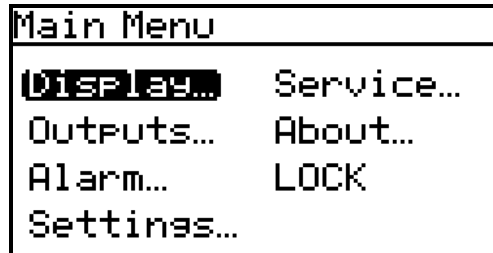

Figure 39: Main Menu

3.3.7 Entering Numeric Values

Since the **Aurora H2O** has no numeric keypad, numeric values are entered using a “combination lock” style of entry:

Use the **left**  and **right**  arrow keys to select the digit to change. The digit selected will be indicated with a .

Use the **up**  and **down**  arrow keys to increment or decrement the digit.

Note: *If incrementing or decrementing a digit would cause the numeric value to exceed its allowable range (maximum/minimum value), the digit will not change.*

Press **Enter**  to save the new value and return (see *Figure 40* below), or **Cancel**  to return, leaving the original value intact.

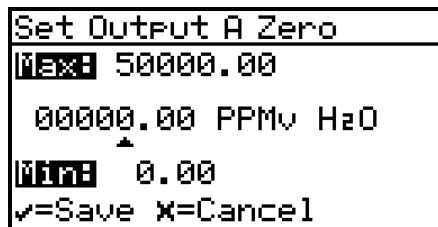
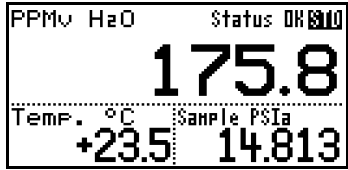

Figure 40: Numeric Entry

3.3.8 Starting Up

After proper installation, the **Aurora H2O** Transmitter can be set up to accommodate the user's requirements. Typically, the user may need to configure the analog outputs, trim the analog outputs, and program the digital outputs. Refer to the Menu Map, Figure 49 on page 75, and complete the following steps. Upon startup, the **Aurora H2O** proceeds through several displays until a screen similar to the following appears:



After startup, the screen will need to be unlocked. To unlock the screen, select



Note: In most instances; use the **Enter** key to save an entry and/or move ahead to the following screen; use the **Cancel** key to reject an entry and/or return to the previous

screen.

3.4 Setting Up the Display

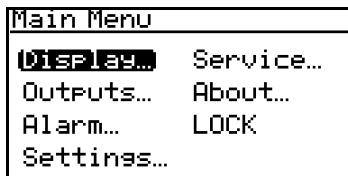

When the screen is unlocked, touch the **Menu** key and the Main Menu appears with several options. To set up the display, select Display... and press **Enter**. The following screen appears:

3.4.1 Selecting Primary Units

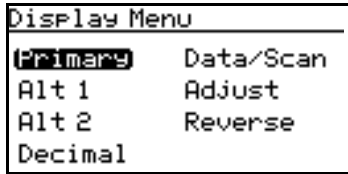

To select units for the primary display, select Primary and press **Enter**. The following screen appears:

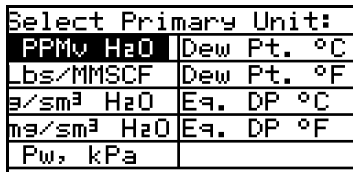

Use the arrow keys to highlight the desired units and press **Enter**. The screen returns to the Display Menu.

3.4.2 Selecting Alt 1 and Alt 2 Units

```

Display Menu
Primary   Data/Scan
Alt 1    Adjust
Alt 2    Reverse
Decimal
  
```

To set the units for Alt 1 and/or Alt 2, use the arrow keys to highlight the one to be set, and press **Enter**. The following screen appears:

```

Display Menu
Choose unit type:
Hygro Temp Press
X=Cancel
  
```

Use the arrow keys to highlight the desired unit type (Hygro, Temperature or Pressure) and press **Enter**. If Temp is selected, the following screen appears.

```

Select Alt 1 Unit:
Temp. °C
Temp. °F
Temp. K
Dew Pt. °C
Dew Pt. °F
  
```

Use the arrow keys to highlight the desired unit and press **Enter**. The screen returns to the Display Menu. Use the same procedure to change other units.

3.4.3 Setting Decimal Places

```

Display Menu
Set Decimal for:
Primary Alt1 Alt2
X=Cancel
  
```

To set the decimal places for unit values, from the Display Menu use the arrow keys to highlight Decimal and press **Enter**. Then select the type of display and press **Enter**.

The decimal places setting determines the number of digits displayed for the value to the right of the decimal symbol ("."), if possible.

```

Set Eq. DP °F Format:
Max 2
1 decimals
0
Save X=Cancel
  
```

Use the arrow keys to change the number of decimal places and press **Enter**, or press **Cancel** if no changes are necessary. The screen returns to the Display Menu.

3.4.4 Data/Scan

```

Display Menu
Primary   Data/Scan
Alt 1    Adjust
Alt 2    Reverse
Decimal
  
```

To toggle the display between showing the numeric values (data), and a graphic plot of the 2f waveform (scan), from the Display Menu use the arrow keys to highlight Data/Scan and press **Enter**. A screen similar to the following appears

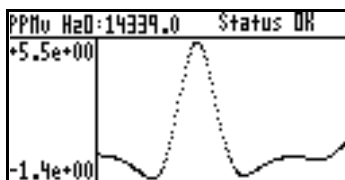

Note: The scan can be used for diagnostic purposes when a PC with **AuroraView** is not readily available.

3.4.5 Adjust

Note: *The display brightness is not adjustable in the current Aurora design; the brightness adjustment is not available.*

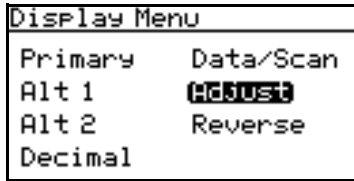

To modify the display contrast and brightness, from the Display Menu use the arrow keys to highlight Adjust and press **Enter**. The following screen appears.

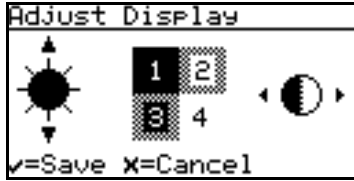

Use the Up/Down arrow keys to increase/decrease display brightness. Use the Right/Left arrow keys to increase/decrease display contrast. Press **Enter** to save the changes, or press **Cancel** to return to the previous setup. The screen returns to the Display Menu.

3.4.6 Reverse

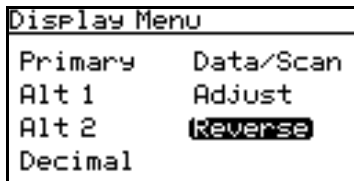

To reverse the text and background shades, from the Display Menu use the arrow keys to highlight Reverse and press **Enter**. The following screen appears.

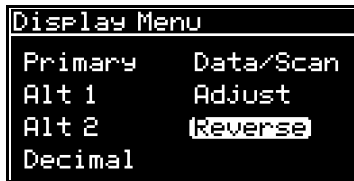

To return to the previous shade setup, select Reverse and press **Enter**. The previous screen appears.

3.5 Setting Up the Outputs

3.5.1 Selecting an Output for Setup



To set up outputs, from the Main Menu choose Outputs... and press **Enter**. The following screen appears.

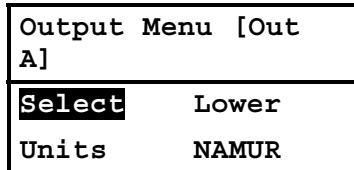

From the Output Menu choose Select and press **Enter**. The following screen appears.

Output Menu [Out A]
Select Output:
B C
X=Cancel

Use the arrow keys to select the output (A, B or C) to be set up, and press **Enter**.

3.5.2 Selecting Output Units

Output Menu [Out A]
Select Lower
Units NAMUR

To adjust the output units, from the Output Menu select Units and press **Enter**. A screen similar to the following appears.

Output Menu [Out A]
Choose unit type:
Hydro Temp Press
X=Cancel

Use the arrow keys to select the unit type and press **Enter**. A screen similar to the following appears:

Select Out A Units:
PPMw H₂O Dew Pt. °C
Lbs/MMSCF Dew Pt. °F
m ³ /m ³ H ₂ O Eq. DP °C
Pw, kPa Eq. DP °F

Use the arrow keys to select a new unit. Press **Enter** to save (or **Cancel** to keep the previous value), and return to the Output Menu.

3.5.3 Selecting an Output Type

Output Menu [Out A]
Select Lower
Units NAMUR

To change the output type, from the Output Menu select Type and press **Enter**. A screen similar to the following appears:

Output Menu [Out A]
Select Output Type:
0-20mA 0-20mA ALM
X=Cancel

Use the arrow keys to select a new output type. Press **Enter** to save (or **Cancel** to keep the previous value), and return to the Output Menu.

Note: If the **ALM** option is selected in the above menu, the analog output will function as an alarm indicator. In this mode, the analog output will remain at 0 mA during normal operating conditions, but the analog output will be driven to 24 mA whenever there is an alarm condition.

3.5.4 Changing the Upper Output Span

Output Menu [Out A]
Select Lower
Units NAMUR

To adjust the upper output span, from the Output Menu select Upper and press **Enter**. A screen similar to the following appears.

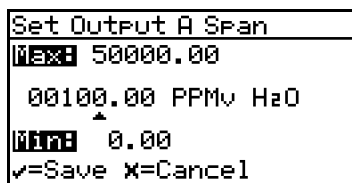

Use the left and right arrow keys to select each digit to be changed and the up and down arrow keys to increase or decrease its value. Press **Enter** to save (or **Cancel** to keep the previous value), and return to Output Menu.

3.5.5 Changing the Lower Output Span

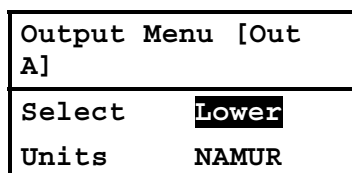

To adjust the lower output span, from the Output Menu select Lower and press **Enter**. A screen similar to the following appears.

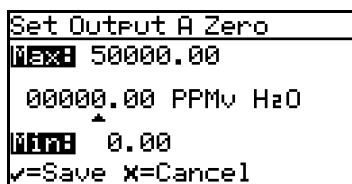

Use the left and right arrow keys to select each digit to be changed and the up and down arrow keys to increase or decrease its value. Press **Enter** to save (or **Cancel** to keep the previous value), and return to Output Menu.

3.5.6 NAMUR Response

The **Aurora H2O** can report measurement failure information via the analog outputs. The signal presentation of failure information is consistent with by the recommendations established by the "User Association of Automation Technology in Process Industries" (NAMUR) published in NE43, version 03.03.2003. When configured for 4-20mA operation, faults and errors are indicated by specific output levels shown in *Figure 41* below:

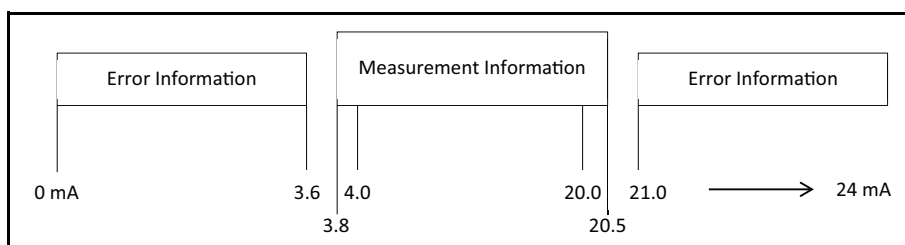

Figure 41: NAMUR Output Value Ranges

In normal operation, a valid measurement is indicated with a signal between 3.8 and 20.5 mA. The Lower (Zero) and Upper (Span) settings determine the measurement value assigned to 4.0 and 20.0 mA, respectively.

For the measurement assigned to an output, the **Aurora H2O** continuously checks if an error has occurred. If an error has occurred, the output will be driven to a current which is within the Error Information bands displayed above. The **Aurora H2O** can signal 3.5 mA ('NAMUR Low') or 21.1 mA ('NAMUR High'). These values are well within the Error Information bands as specified by NAMUR (see *Table 3* below).

Note: *The Aurora H2O will never produce a signal between 3.6-3.8 mA or between 20.5-21.0 mA, to allow for reliable discrimination between a measurement and an error.*

Table 3: Signal Messages

Error	Description	Signal
Under Range	The measurement is less than the calibrated range of the analyzer	NAMUR Low
Over Range	The measurement is greater than the calibrated range of the analyzer	NAMUR High
Out of Range	Calculation error or associated measurement (Temp/Pressure) invalid	NAMUR High
No Data	Measurement value has not been calculated yet	NAMUR High
No Calibration	Moisture calibration table empty/invalid	NAMUR High

3.5.6.1 NAMUR Filtering

There may be situations where the NAMUR signaling behavior is undesirable (see Table 4 below). For example, a process operating at or near the **Aurora H2O** calibration limits, or when connected to a SCADA or DCS system that cannot correctly distinguish between a measurement and an error signal. In these cases, the NAMUR reporting behavior can be suppressed (“inhibited”). From the Output menu, select NAMUR:

```
Output Menu [Out
A]
Select      Lower
Units      NAMUR
```

Then select the error(s) to inhibit:

```
Output Menu [Out A]
Inhibit NAMUR for:
NONE LoRng HiRng
Lo+Hi ALL
X=Cancel
```

Table 4: NAMUR Errors

Selection	Result
NONE	No errors are inhibited; NAMUR signaling will occur for any error as shown in the table above.
LoRng	Under Range errors are inhibited; NAMUR signaling will NOT occur for Under Range error conditions. NAMUR signaling will occur for all other errors in the table above.
HiRng	Over Range errors are inhibited; NAMUR signaling will NOT occur for Over Range error conditions. NAMUR signaling will occur for all other errors in the table above.
Lo+Hi	Under Range AND Over Range errors are inhibited; NAMUR signaling will NOT occur for these error conditions. NAMUR signaling will occur for all other errors in the table above.
ALL	ALL errors are inhibited; NAMUR signaling will NOT occur for any error in the table above.

3.5.7 Testing the Output

```
Output Menu [Out
A]
Select      Lower
Units      NAMUR
```

The Test Menu causes the **Aurora H2O** to generate a 0- or 4-20mA output at the percent of scale selected. For example, in 4-20 operation, 0% = 4mA, 50% = 12mA, 100% = 20mA. This allows the proper function of recording or SCADA equipment to be verified. In 0-20 operation, 0% = 0mA, 50% = 10mA, 100% = 20mA.

```
Output A Test Value:
Max +110.00
+050.00 %
Min -25.00
✓=Save X=Cancel
```

To test system output, from the Output Menu select Test and press **Enter**. The **Aurora H2O** will proceed to check the settings, and a screen similar to this display will appear.

Use the left and right arrow keys to select each digit to be changed, and the up and down arrow keys to increase or decrease its value. Press **Enter** to save (or **Cancel** to keep) the previous value, and return to the Output Menu.

Check your output wiring. If the reading on your SCADA or DCS is off slightly, then you may use the Trim feature to trim the output zero or span.

3.5.8 Trimming the Outputs

The Trim Menu enables the operator to compensate for differences in measurement of the 0/4-20 mA outputs by connected recorders or SCADA equipment. To trim the output:

```
Output Menu [Out
A]
Select      Lower
Units      NAMUR
```

Select Trim from the Output Menu and press **Enter**. The following screen appears.

Note: The trim applies to whichever output is chosen with the Select menu item, and displayed on the menu title bar.

```
Trim Menu [Out A]
Reset Trim
Trim Zero
Trim Span
```

When performing a Trim operation, the **Aurora H2O** unit requires you to first reset the trim. To reset the trim output, highlight Reset Trim and press **Enter**. The following screen appears.

```
Trim Menu [Out A]
Reset Out A Trim?
YES NO
X=Cancel
```

Use the left or right arrow keys to highlight YES and press **Enter**. This cancels any previous trim values, and returns the **Aurora H2O** to its factory adjustment. The display returns to the previous screen with Trim Zero highlighted.

```
Trim Menu [Out A]
Reset Trim
Trim Zero
Trim Span
```

To trim the zero value, press **Enter**. A screen similar to the following appears.

This will cause the **Aurora H2O** to output 4.000 mA on the output being trimmed. The output value should then be read using the connected recorder, SCADA equipment, or DVM. Enter the value read from the connected equipment as the Zero Trim value, as follows:

3.5.8 Trimming the Outputs (cont.)

Note: Since you cannot trim 0 mA for negative offsets, trim for the lower end of the scale is at the 4 mA output level.

```
Enter Out A Readings:
Max: 5.2000
 04.0000 mA
  ▲
Min: 3.0000
√=Save X=Cancel
```

Use the left and right arrow keys to select each digit to be changed, and the up and down arrow keys to increase or decrease its value. Press **Enter** to save (or **Cancel** to keep the previous value).

```
Trim Menu [Out A]
Reset Trim
Trim Zero
Trim Span
```

The Trim Menu returns with Trim Span highlighted. To change the span value, press **Enter**. A screen similar to the following appears.

This will cause the **Aurora H2O** to output 20.000 mA on the output being trimmed. The output value should then be read using the connected recorder, SCADA equipment, or DVM. Enter the value read from the connected equipment as the Span Trim value.

```
Enter Out A Readings:
Max: 22.2000
 20.0000 mA
  ▲
Min: 10.0000
√=Save X=Cancel
```

Use the left and right arrow keys to select each digit to be changed, and the up and down arrow keys to increase or decrease its value. Press **Enter** to save (or **Cancel** to keep the previous value).

Trimming is complete. Accuracy can be verified using the Test Menu, above.

Example: Trim is reset, then Trim Zero is selected. The SCADA input reports 3.977 mA.

The operator enters "3.977" as the Zero Trim value.

Trim Span is selected. The SCADA input reports 19.985 mA.

The operator enters "19.985" as the Span Trim value.

Aurora H2O adjusts the output accordingly to true the output as read by the customer recorder, SCADA or DVM. Using the Test Menu, the operator verifies that a test value of 0% now reads 4.000 mA at the SCADA equipment, and a test value of 100% now reads 20.000 mA.

3.6 Setting Up the Alarms

Note: The **Aurora H2O** is **not** equipped with alarm relays. Alarm status can be obtained via Modbus, or an Analog Output can be configured as an alarm signal (see "Selecting an Output Type" on page 43).

3.6.1 Selecting an Alarm Output

```
Alarm Menu [A]
Select Upper
Status Lower
Units
Type...
```

To set up alarm outputs, on the Main Menu choose Alarm and press **Enter**. From the Alarm Menu choose Select and press **Enter**. A screen similar to the following appears.

```
Alarm Menu [A]
Select Alarm:
(A) B C
X=Cancel
```

Use the arrow keys to select the output (A, B or C) to be set up and press **Enter**. The display returns to the Alarm Menu.

3.6.2 Selecting Alarm Status

Alarm Menu [A]	
Select	Upper
Status	Lower
Units	
Type...	

To select the alarm status, from the Alarm Menu select Status and press **Enter**. The following screen appears:

Alarm Menu [A]	
Set Alarm Status:	
OFF	ON
X=Cancel	

Use the arrow keys to select OFF or ON and press **Enter**. The display returns to the Alarm Menu.

3.6.3 Selecting Alarm Units

Alarm Menu [A]	
Choose unit type:	
Hygro	Temp Press
X=Cancel	

To select alarm units, from the Alarm Menu select Units and press **Enter**. Use the arrow keys to select the unit type and press **Enter**.

Select Alarm A Units:	
PPMv H ₂ O	Dew Pt. °C
Lbs/MMSCF	Dew Pt. °F
mg/m ³ H ₂ O	Eq. DP °C
Pw. kPa	Eq. DP °F

If Hygro was selected, this display appears. Use the arrow keys to select a unit. Press **Enter** to save (or **Cancel** to keep the previous value), and return to the Alarm Menu.

Select Alarm A Units:	
Temp. °C	
Temp. °F	
Temp. K	
Dew Pt. °C	
Dew Pt. °F	

If Temperature was selected, this display appears. Use the arrow keys to select a unit. Press **Enter** to save (or **Cancel** to keep the previous value), and return to the Alarm Menu.

Alarm Menu [A]	
Choose Pressure type:	
Sample	Line
X=Cancel	

If Pressure was selected, this display appears. Use the arrow keys to select a unit. Press **Enter** to save (or **Cancel** to keep the previous value), and return to the Alarm Menu.

3.6.4 Selecting an Alarm Type

Alarm Menu [A]	
Select	Upper
Status	Lower
Units	
TYPE...	

To change the alarm type, from the Alarm Menu select Type and press **Enter**. A screen similar to the following appears:

Select Alarm Type:	
Setpoint	
In Band	
Out Band	
Fault	

Use the arrow keys to select an alarm type. Press **Enter** to save (or **Cancel** to keep the previous value), and return to the Alarm Menu.

- **SetPoint:** Alarm activates when parameter exceeds upper limit, and deactivates when parameter is less than lower limit.
- **Inner Band:** Alarm activates when parameter is between upper and lower limits.
- **Outer Band:** Alarm activates when parameter is outside upper and lower limits.
- **Fault:** Alarm activates when a system fault is detected. The alarm de-activates when the fault condition is removed. These conditions can be found in Section 7.4, Table 4.

3.6.5 How the Alarm Types Work

See Figure 42 below for descriptions of the various alarm types:

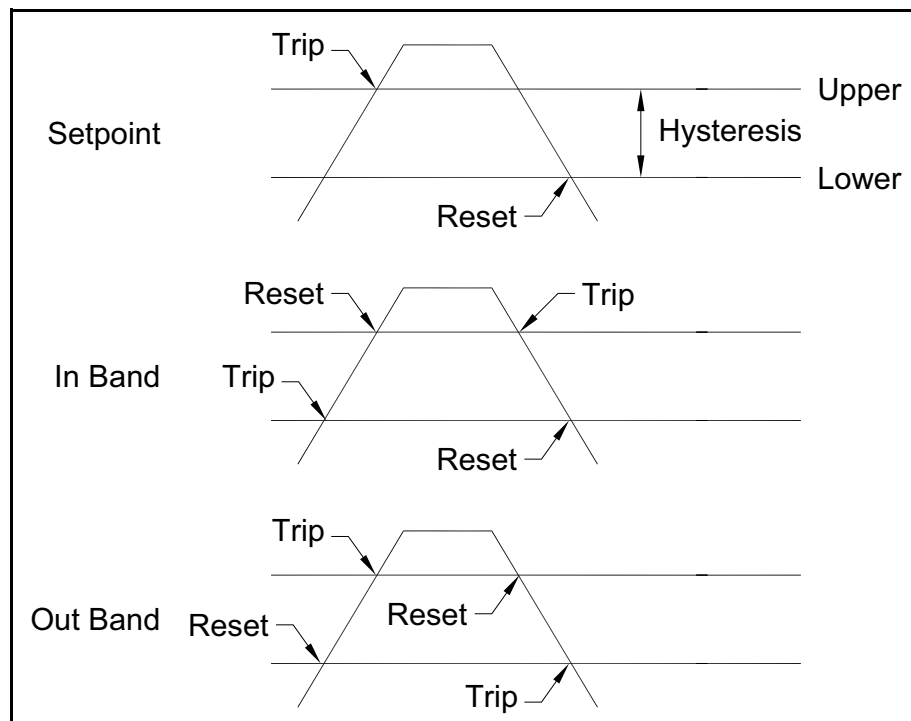

Figure 42: Example of Alarm Types

3.6.6 Changing the Upper Alarm Span

```
Alarm Menu [A]
Select    UPPER
Status    Lower
Units
Type...
```

To adjust the upper alarm span, from the Alarm Menu select Upper and press **Enter**. A screen similar to the following appears.

```
Enter MAX Alm Value
MAX 413.680
50.000 kPa
  ▲
MIN 0.000
✓=Save X=Cancel
```

Use the left and right arrow keys to select each digit to be changed and the up and down arrow keys to increase or decrease its value. Press **Enter** to save (or **Cancel** to keep the previous value), and return to Output Menu.

3.6.7 Changing the Lower Alarm Span

```
Alarm Menu [A]
Select    Upper
Status    LOWER
Units
Type...
```

To adjust the lower alarm span, from the Alarm Menu select Lower and press **Enter**. A screen similar to the following appears.

```
Enter MIN Alm Value
MAX 413.680
50.000 kPa
  ▲
MIN 0.000
✓=Save X=Cancel
```

Use the left and right arrow keys to select each digit to be changed and the up and down arrow keys to increase or decrease its value. Press **Enter** to save (or **Cancel** to keep the previous value), and return to Output Menu.

Chapter 4. Programming Advanced Features

4.1 Comm Port Settings

Main Menu	
Display...	Service...
Outputs...	About...
Alarm...	LOCK
Settings...	

To access the communication port settings, from the Main Menu select Settings and press **Enter**. The following screen appears:

Settings Menu	
Comms...	Pressure...
Adjust...	Locale...
Gas...	User Cal...
Clock...	Ethernet...

To access the communications port settings, select Comms... and press **Enter**. The following screen appears:

4.1.1 Selecting a Comm Port

Comm Port: [SCADA]	
Select	Network ID
Baud Rate	
Parity	
Protocol	

There are two physical comm ports in the **Aurora H2O**. Comm Port 1 is aligned to SCADA in the instrument program and Comm Port 2 is aligned to *SERVICE*. This setup enables the user to have Comm Port 1 set up for the primary digital output (for example, RS-485 to the customer SCADA system), and Comm Port 2 to be used for service (for example, to enable a service engineer to interface with the **Aurora H2O** using an RS-232 cable connected to a laptop PC in the field, running **AuroraView** software).

To select a communication port, use the arrow keys to highlight Select and press **Enter**. The following screen appears.

Comm Port: [SCADA]	
Select Comm Port:	
SERVICE	SERVICE
X=Cancel	

Select SCADA or SERVICE and press **Enter**. The screen returns to the Comm Port Menu.

4.1.2 Setting the Baud Rate

Comm Port: [SCADA]	
Select	Network ID
Baud Rate	
Parity	
Protocol	

To set the baud rate, from the Comm Port Menu select Baud Rate and press **Enter**. The following screen appears.

Select Baud Rate:	
115.2k	19.2k
57.6k	9600
38.4k	4800

Use the arrow keys to highlight the desired baud rate and press **Enter**. The screen returns to the Comm Port Menu.

4.1.3 Setting the Parity

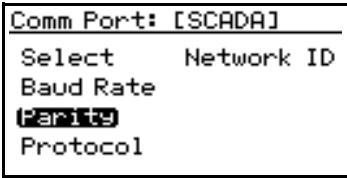

To set parity, from the Comm Port Menu select Parity and press **Enter**. The following screen appears.

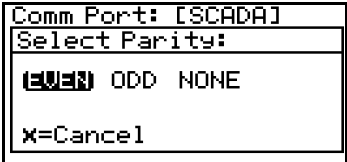

Use the arrow keys to highlight the desired parity and press **Enter**.

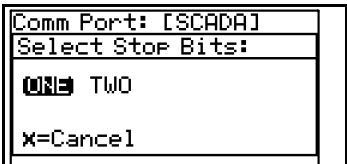

After a parity selection is made, the Aurora prompts for the number of stop bits. Use the arrow keys to highlight the desired number and press **Enter**. The screen returns to the Comm Port Menu.

4.1.4 Selecting the Protocol

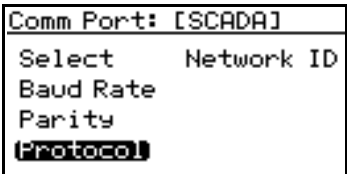

To choose the protocol, from the Comm Port Menu select Protocol and press **Enter**. The following screen appears.

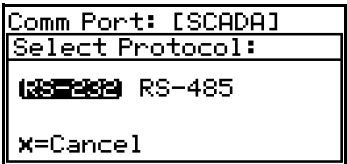

Use the arrow keys to highlight the desired protocol and press **Enter**. The screen returns to the Comm Port Menu.

4.1.5 Setting the Network ID

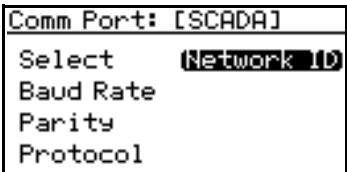

To set the network ID, from the Comm Port Menu select Network ID and press **Enter**. The following screen appears.

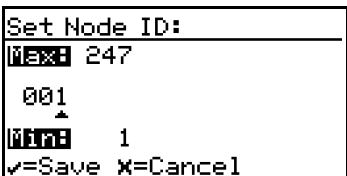

Use the left and right arrow keys to select each digit to be changed. Use the up and down arrow keys to change the value. When finished, press **Enter**. The screen returns to the Comm Port Menu.

4.1.6 Adjusting the Response Delay

Some Modbus masters may have limitations in their ability to receive a response immediately after transmitting the request. This can often occur when the RS-485 protocol is used, as the Master must change from transmit to receive operation. The Aurora H2O response can be delayed by a user-specified amount to accommodate these limitations.

```
Comm Port: [SCADA]
Select      Network ID
Baud Rate  [Response]
Parity      Test
Protocol
```

To change the response time, from the Comm Port Menu select Response and press **Enter**. The following screen appears.

```
Response Delay:
Hex: 200
000 msec
  ^
Hex: 0
✓=Save X=Cancel
```

Use the left and right arrow keys to select each digit to be changed. Use the up and down arrow keys to change the value. When finished, press **Enter**. The screen returns to the Comm Port Menu. A value of zero permits the Aurora to respond immediately. Do not specify a response delay longer than absolutely necessary, as this limits message throughput.

4.1.7 Serial Port Test

To aid in establishing or troubleshooting problems with serial communications, the Aurora H2O can be placed in *Serial Port Test* mode, using a serial terminal or terminal emulation software. Configure the terminal to the same parameters specified for the Aurora H2O in “Setting the Baud Rate” on page 51, “Setting the Parity” on page 52 and “Selecting the Protocol” on page 52.

Note: Modbus communications are **not** possible via the port under test.

```
Comm Port: [SCADA]
Select      Network ID
Baud Rate  Response
Parity      [Test]
Protocol
```

To change the response time, from the Comm Port Menu select Test and press **Enter**. The following screen appears.

```
Comm Port: [SCADA]
Serial Port Test
OFF [ON]
X=Cancel
```

Enable Test mode by selecting ON and pressing **Enter**. The Aurora H2O transmits SCADA waiting or SERVICE waiting (see *Figure 43* below), depending on the port being tested.

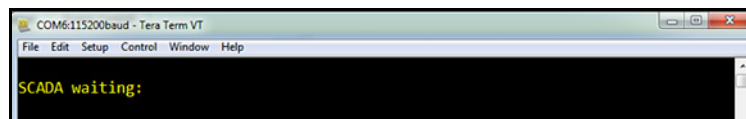

Figure 43: Sample “SCADA Waiting:” Screen

4.1.7 Serial Port Test (cont.)

Type a character at the terminal. If the character is received correctly, the hexadecimal value of the character sent will be returned (see *Figure 44* below). If the character is not returned, this is usually due to incorrect parity or stop-bit settings. If the initial waiting prompt is not seen or is garbled, this is an indication of an incorrect baud rate setting.

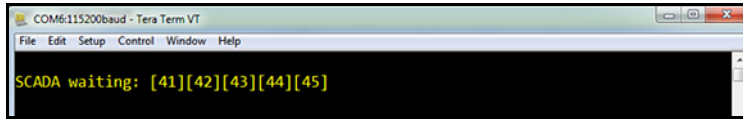

Figure 44: Response to “ABCDE” Entry

Note: The Aurora H2O will remain in test mode until it is turned off or it is reset or power-cycled.

4.2 Ethernet Settings

The Aurora H2O supports Modbus/TCP over Ethernet. This enables remote access to measurement and diagnostic data whenever an Ethernet LAN connection is available.

4.2.1 Connection to the Internet/WAN



WARNING! The Ethernet option provided in the Aurora H2O is designed for use on a limited-access Local Area Network (LAN) protected by a suitable firewall. It should not be operated if exposed to the Internet or other unmanaged Wide Area Network (WAN). Check with your network administrator to determine whether it is safe to connect the Aurora H2O to your network infrastructure.

4.2.2 Default Passwords



WARNING! The Ethernet option in the Aurora H2O is based on technology from Digi International Inc. It includes built-in HTTP (web) and Telnet servers to provide administrative access and control. As shipped from the factory, there are two accounts enabled, with default passwords assigned. These default passwords are public knowledge, and widely distributed.



WARNING! It is *IMPERATIVE* that the *default passwords* be changed before placing the Aurora H2O into service!

4.2.3 Connecting to an Ethernet LAN

The Ethernet option supports the 10Base-T and 100Base-TX twisted-pair Ethernet standards. Screw terminal connectors are provided on the *Aurora Terminal Board* for connection to the LAN. The Ethernet cable should be inserted into an available cable gland, and fed through the increased safety compartment to the terminal board. The cable should be prepared as described in *Step 6 on page 28*.

```
Ethernet Settings
Status
Protocol
Factory Reset
```

To access the Ethernet Settings menu, enter your User passcode (**2719** is the default). To activate the Ethernet port, select the Status option and press **Enter**. The following screen appears.

```
Ethernet Settings
Ethernet Status
Disabled Enabled
X=Cancel
```

When the Status is set to Disabled, power is removed from the module, effectively unplugging it from the Ethernet network. If the Status is returned to Enabled, there will be a delay of up to one minute before the module completes its *Power On Self Test (POST)* and becomes visible on the Ethernet network. After selecting the desired option, press **Enter**. [Note that the Disabled option is the default setting.]

IMPORTANT: If the Ethernet Settings menu is “gray” or missing, your Aurora does not have Ethernet capability.

```
Ethernet Settings
Status
Protocol
Factory Reset
```

Selecting Factory Reset from the Ethernet Settings menu returns the Ethernet module to its default state, which takes approximately 15 seconds to complete. After a Factory Reset, the module enables DHCP, reset passwords to their defaults, disables Modbus/TCP, and enables RealPort (serial emulation) mode. After a Factory Reset, it is necessary to log in via the HTML or Telnet command interface, and reconfigure the network and Modbus settings (see *Appendix B. “Aurora H2O Ethernet Operation”* for detailed instructions).

4.2.4 IP Address Assignment

By default, Aurora uses the *Dynamic Host Configuration Protocol (DHCP)* to obtain an *Internet Protocol (IP)* address from the network controller or router. If a DHCP server is not available, a static IP address must be selected and assigned. This is performed via the HTTP or Telnet interface.

If an IP address is obtained from a DHCP server, that server may be used to identify the IP address assigned, or the IP address may be determined with a *Device Discovery Utility*.

If no DHCP server is provided, after several minutes the Aurora will default to a Link Local Address per IETF RFC 3927. The Aurora will assign itself a random IP address in the range of 169.254.1.0 - 169.254.254.255.

4.2.5 Device Discovery

The Digi module used for Ethernet connectivity supports Digi's ADDP (*Advanced Device Discovery Protocol*). ADDP uses UDP port 2362 and a multicast IP address of 224.0.5.128. You will need to enable these on your firewall for the ADDP protocol to work for the device discovery utility.

Digi provides two utilities, *Digi Device Discovery* (for Microsoft Windows only), and *Digi Port Authority* (available for Microsoft Windows, AIX, HP-UX, Solaris, and many Linux distributions). These utilities can be downloaded from the Digi support web site at: <http://www.digi.com/support/>. After the utility is installed, the Aurora H2O connected to the LAN, and the Ethernet option enabled, *Device Discovery* will identify it (see *Figure 45* below):

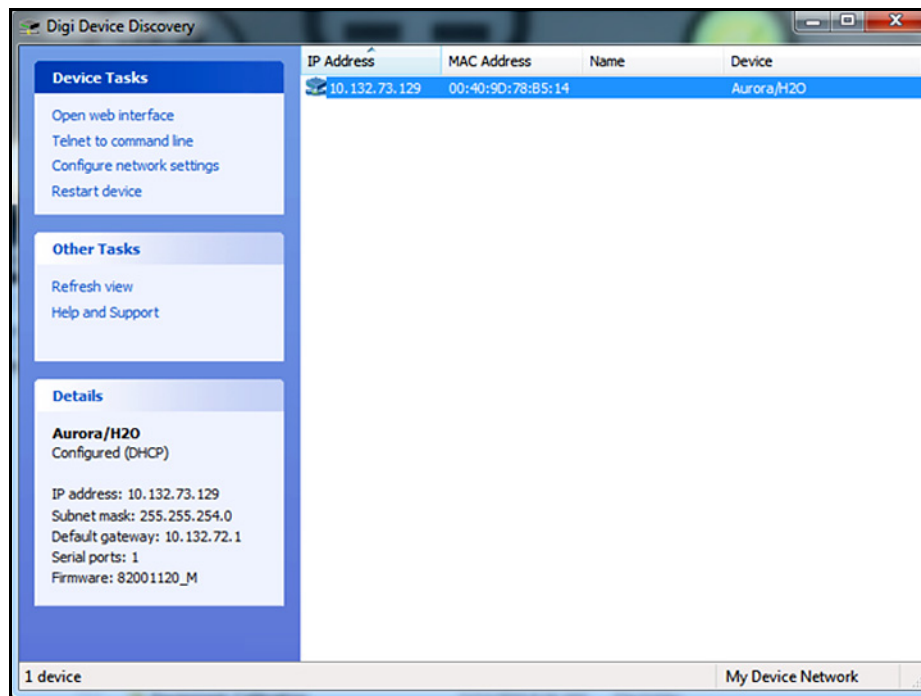

Figure 45: Digi Device Discovery Screen

Advanced configuration may then be performed by opening a web browser or telnet session to the IP address listed for the Aurora H2O. See *Appendix B. "Aurora H2O Ethernet Operation"* for detailed instructions.

Note: *The Ethernet module is not enabled and the Aurora H2O will not be visible on the network until the Aurora completes laser startup.*

4.3 Adjust Offset Values

```
Settings Menu
Comms...   Pressure...
Adjust...  Locale...
Gas        Ethernet...
Clock...
```

To adjust offset values, from the Settings Menu select Adjust... and press **Enter**. The following screen appears.

4.3.1 Adjusting the PPMv Offset

```
User Adjustments
PPM Level
Filters...
Calc Method...
```

To adjust the PPMv offset, select PPM Level and press **Enter**. The following screen appears.

```
PPMv Offset:
Max: +25.00
+00.00 PPM
  ^
Min: -25.00
v=Save x=Cancel
```

Use the left and right arrow keys to select each digit to be changed. Use the up and down arrow keys to change the value. When finished, press **Enter**. The screen returns to the User Adjustments Menu.

4.3.2 Adjusting the Smoothing Filter

```
User Adjustments
PPM Level
Filters...
Calc Method...
```

To adjust the smoothing filter, from the User Adjustments Menu select Filter and press **Enter**. The following screen appears.

```
Filters
Smoothing
Scan Avg
```

Select Smoothing and press **Enter**. The following screen appears.

```
Smoothing Filter:
Max: 501
128 scans
  ^
Min: 1
v=Save x=Cancel
```

The Smoothing Filter setting is used to change the system responsiveness. It is a moving average filter to smooth the moisture readings. The minimum setting is 1scan and the maximum setting is 501 scans. The default value of 128 scans, is set at the factory prior to shipment.

Use the left and right arrow keys to select each digit to be changed. Use the up and down arrow keys to change the value. When finished, press **Enter**. The screen returns to the User Adjustments menu.

4.3.3 Adjusting the Scan Averaging

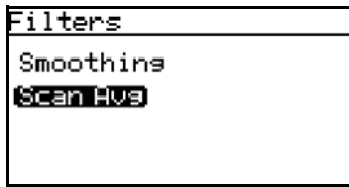

To adjust the Scan Averaging, from the **Filters Menu** select **Scan Avg** and press **Enter**. The following screen appears:

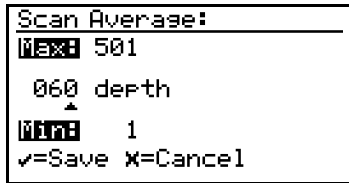

The Scan Average setting is used to change system noise rejection. By averaging entire scans, the Signal/Noise Ratio (SNR) can be increased. This is particularly useful in the presence of certain background gases, which can interfere with the moisture absorption peak, or introduce background noise.

The default Scan Average value set at the factory is 128, which is an optimal tradeoff between noise reduction and system responsiveness. Lowering this value provides faster response time in exchange for a noisier measurement; conversely, increasing the scan average provides a smoother measurement in exchange for slower transient response.

IMPORTANT: Please contact a Panametrics application engineer before modifying this setting.

Use the left and right arrow keys to select each digit to be changed. Use the up and down arrow keys to change the value. When finished, press **Enter**. The screen returns to the User Adjustments Menu.

4.3.4 Setting the Dew Point Calculation Method

- The **dew point** is the temperature at which the air is saturated with respect to water vapor over a **liquid** surface.
- The **frost point** is the temperature at which the air is saturated with respect to water vapor over an **ice** surface.

There can be a difference of several degrees C between the dew point and the frost point.

- When set for Dew/Frost, the **Aurora H2O** will report the *Dew Point* if the reading is above freezing, and will report the *Frost Point* if the reading is below freezing.
- When set for Dew Point, the **Aurora H2O** will calculate the *Dew Point* temperature, even if that temperature is below freezing.

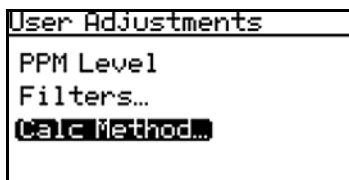

To set the dew point calculation method, from the User Adjustments Menu select Dew Pt Calc and press **Enter**. The following screen appears.

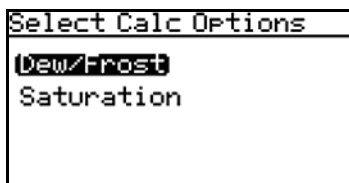

From the Select Calc Options Menu select Dew/Frost and press **Enter**. The following screen appears.

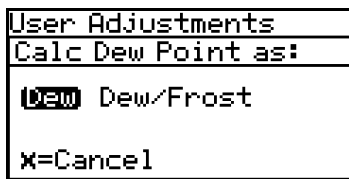

Use the arrow keys to highlight the desired dew point setting and press **Enter**. The screen returns to the User Adjustments Menu.

- The Dew calculation should be used for compatibility with ASTM-1142/IGT-8. The tables and calculations in those reports require measurements and provide results in dew point, regardless of the actual phase (dew or frost).
- The Dew/Frost calculation should be used for compatibility with ISO-18453:2004, or when using a chilled mirror apparatus as a check standard.

4.3.5 Saturation Calculation

In certain regulatory zones, the *Gosudarstvenii Standart (GOST)* calculation of the Saturation pressure is required, and gives different results from ASTM and ISO methods. Select the calculation that is most appropriate for your application.

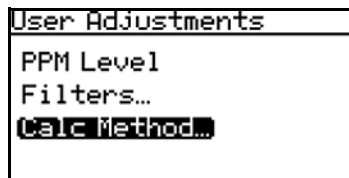

To select the appropriate *Saturation Calculation* method for your application, from the User Adjustments Menu select Calc method and press **Enter**. The following screen appears.

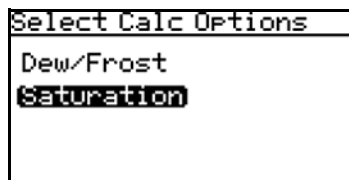

From the Select Calc Options Menu select Saturation and press **Enter**. The following screen appears.

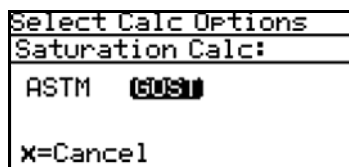

Use the arrow keys to highlight the desired saturation calculation method (ASTM or GOST) and press **Enter**. The screen returns to the User Adjustments Menu.

4.4 Set Up the Background Gas

4.4.1 Selecting the Type of Gas

The **Aurora H2O** TDLAS is normally calibrated to a standard gas mixture that is representative of “typical” natural gas. The primary components and concentrations of this gas mixture are:

Component	Concentration
Methane (CH ₄)	90.0%
Nitrogen (N ₂)	10.0%

The process background gas is selectable from the Settings Menu.

- For normal operation in natural gas service, STD should be selected as the background gas.
- For verification testing in **pure methane**, select CH₄.
- If verifying in Nitrogen with a known moisture concentration, N₂ should be selected as the background gas.



The **Aurora H2O** displays the selected Background Gas as an indicator in the upper right corner of the LCD, adjacent to the status message.

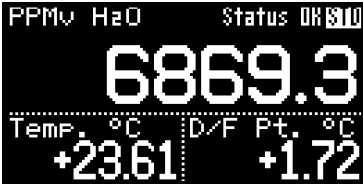

Unless otherwise requested, the **Aurora H2O** is shipped from the factory configured for Methane operation

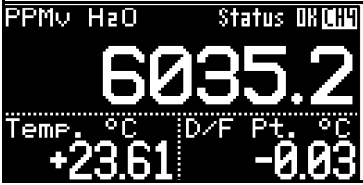

To change the type of background gas, from the Settings Menu select Gas and press **Enter**. The following screen appears.

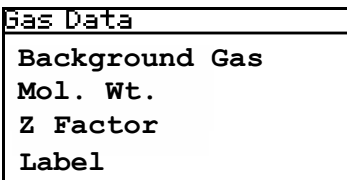

From the Gas Data menu, select Background and press **Enter**. The following screen appears.

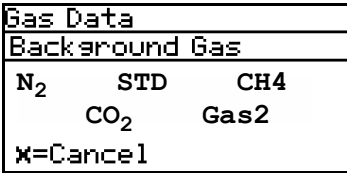

Use the arrow keys to select the desired background gas, and press **Enter**. The background gas selection is now complete. Press **Cancel** to return to the display page.

Note: Selecting either Gas1 or Gas2 enables the Label menu item. This menu opens a keyboard display that allows the user to change the 'Gas1/2' label to one of their own choosing. Entering the Label menu requires the User passcode (2719).

4.4.2 Setting the Z Factor

The **Z factor** is a number that accounts for the non-ideal compressibility of natural gas, and is vital for accurate calculation of mass/volume (lbs/MMSCF, mg/m³).

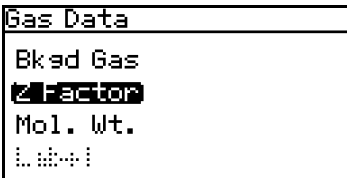

To set the **Z factor**, from the Gas Data Menu, select Z Factor and press enter. The following screen appears.

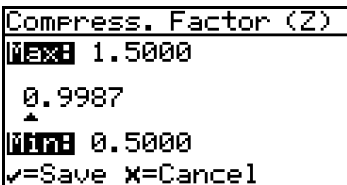

Use the left and right arrow keys to select each digit to be changed. Use the up and down arrow keys to change the value. When finished, press **Enter**. The screen returns to the Settings Menu.

4.4.3 Entering a Label

Selecting either Gas1 or Gas2 enables the Label menu item. This menu opens a keyboard display that allows the user to change the 'Gas1/2' label to one of their own choosing. Entering the Label menu requires the User passcode (2719).

To enter/edit a label:

Selecting the Label menu item displays the Alphanumeric Entry control (see *Figure 46* below).

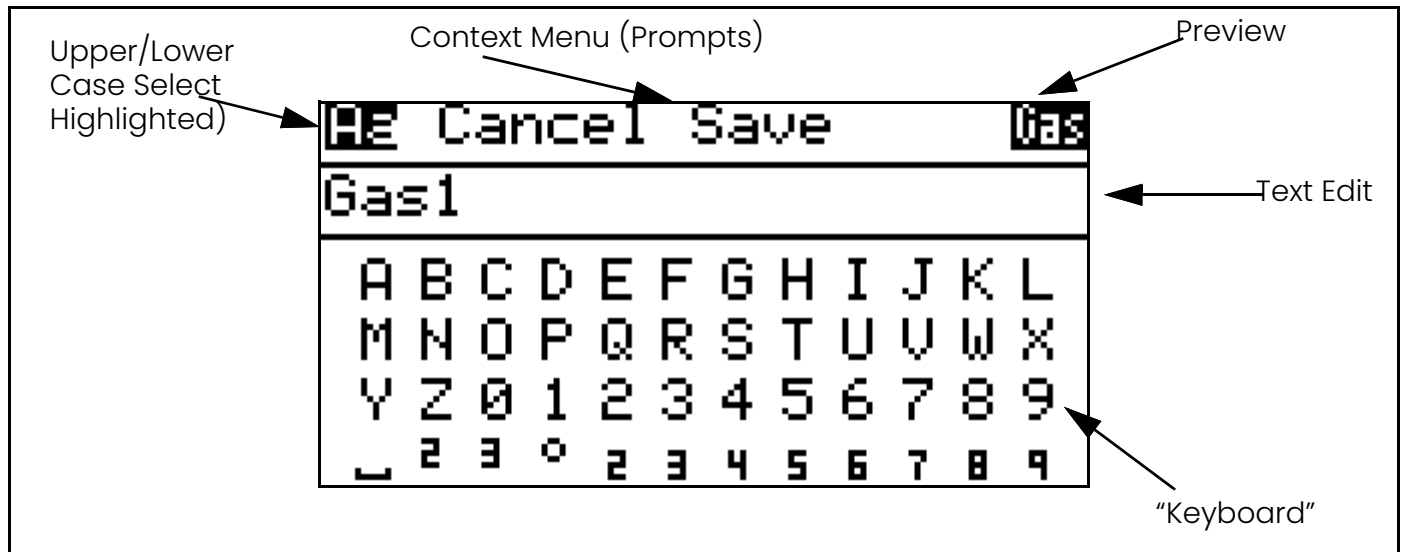

Figure 46: Alphanumeric Entry Control

The alpha menu is divided into three sections. The active section will have something highlighted (reverse video). The **Up/Down** arrows are used to move between sections.

The top section is the **Context Menu**. The 'Aa' toggles the keyboard between upper and lower case (shift key). **Cancel** abandons any changes to the label. **Save** saves any changes made to the label. There is also a 'preview' of how the label will look from the main data display.

- Pressing the **Down** arrow will move the highlight to the **Text Edit** section (see *Figure 47* below):

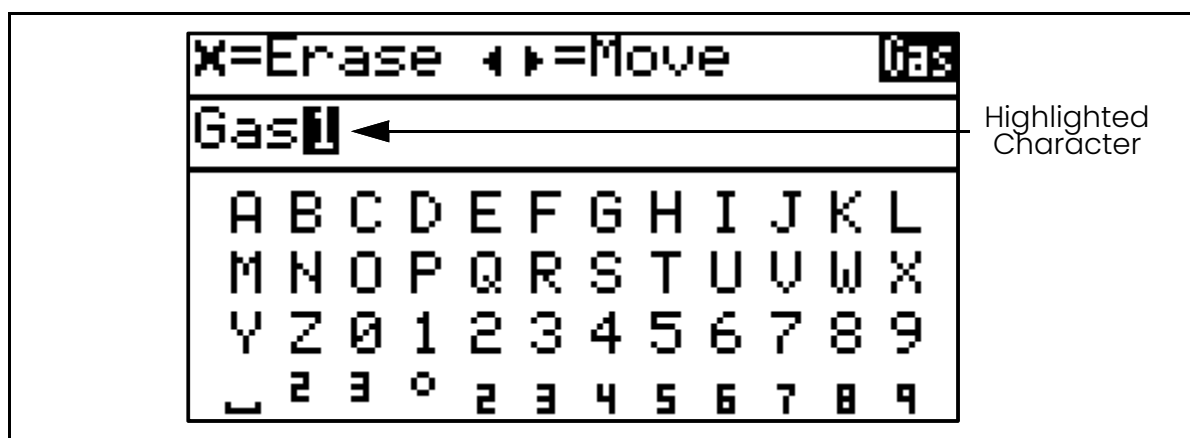

Figure 47: Text Edit

Note that the **Context Menu** has changed; it displays prompts of available key actions.

- In **Text Edit**, the **Left** and **Right** arrows move the highlight from character to character in the label. Pressing **x** erases the highlighted character.
- Pressing the **Down** arrow will move the highlight to the **Keyboard** section (see *Figure 48* below):

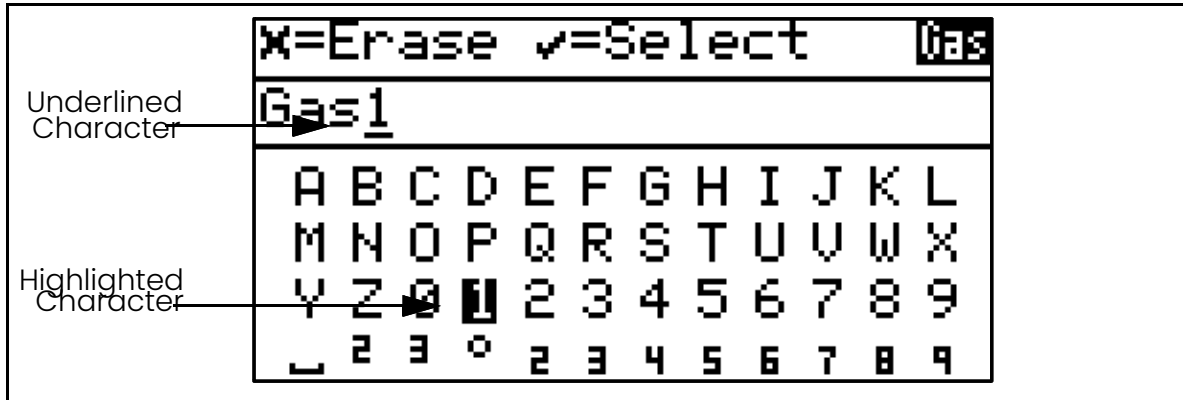

Figure 48: Alphanumeric Menu with Keyboard Highlighted

Note that the **Context Menu** has changed again; it displays prompts of available key actions when in the keyboard. In **Keyboard**, the **Left / Right / Up / Down** arrows move the highlight from character to character in the keyboard.

Note that the character selected in **Text Edit** is now underlined.

- Pressing **Enter** replaces the underlined character with the character highlighted on the keyboard.
- Pressing **Cancel** erases the underlined character. Any characters after the erased character are shifted to the left. If there are no characters after the erased character, the underline moves to the last character in the label.
- When in the **Keyboard**, pressing the **Down** arrow repeatedly will move the highlight down to the next row of 'keys'. When the highlight is on the bottom row, pressing **Down** will move the highlight to the top row.
- Pressing the **Up** arrow will move the highlight up to the previous row of keys. When the highlight is on the top row, pressing **Up** will switch to the **Text Edit** section.
- From the **Text Edit** section, pressing **Up** will move the highlight to the **Context Menu** section.
- Choose **Cancel** or **Save** to exit the Label entry.

4.4.4 Adjusting the Gas Offset



The input information for gas molecular weight is not currently used for any moisture calculations and is reserved for future use.

- lbs/MMSCF is calculated using IGT Research Bulletin #8 and ASTM D-1142-95 referenced at 60°F, 1 ATM.
- mg/cm³ is based on ideal gas law derivation referenced at 15°C, 1.01325 kPa.

To adjust the gas molecular weight offset, from the Settings Menu select Gas and press **Enter**. From the Gas Data menu select Mol. Weight and press **Enter**. The following screen appears.

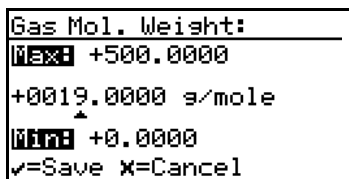

Use the left and right arrow keys to select each digit to be changed. Use the up and down arrow keys to change the value. When finished, press **Enter**. The screen returns to the Settings Menu.

4.5 Clock Settings



The clock settings are for informational purposes. They are used to keep track of the test analyzer start time and the laser operational time.

To reset the clock, from the Settings Menu select Clock and press **Enter**. The following screen appears.

4.5.1 Resetting the Hour

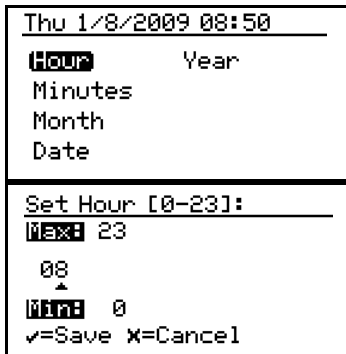

To reset the hour, from the Clock Menu select Hour and press **Enter**. The following screen appears.

Use the left and right arrow keys to select each digit to be changed. Use the up and down arrow keys to change the value. When finished, press **Enter**. The screen returns to the Clock Menu.

4.5.2 Resetting the Minutes

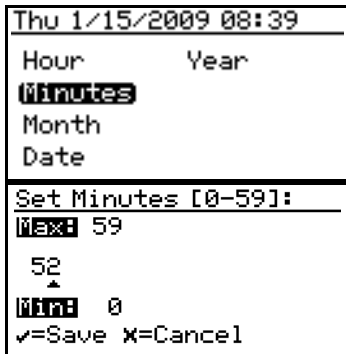

To reset the minutes, from the Clock Menu select Minutes and press **Enter**. The following screen appears.

Use the left and right arrow keys to select each digit to be changed. Use the up and down arrow keys to change the value. When finished, press **Enter**. The screen returns to the Clock Menu.

4.5.3 Resetting the Month

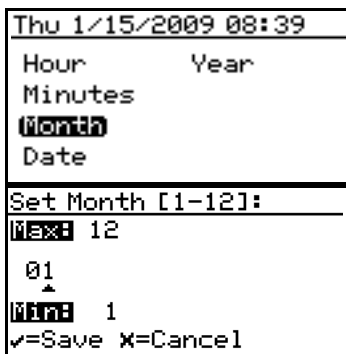

To reset the month, from the Clock Menu select Month and press **Enter**. The following screen appears.

Use the left and right arrow keys to select each digit to be changed. Use the up and down arrow keys to change the value. When finished, press **Enter**. The screen returns to the Clock Menu.

4.5.4 Resetting the Date

```
Thu 1/15/2009 08:39
-----
Hour      Year
Minutes
Month
Date
```

To reset the date, from the Clock Menu select Date and press **Enter**. The following screen appears.

```
Set Date:
-----
Max: 31
 08
 ^
Min: 1
√=Save X=Cancel
```

Use the left and right arrow keys to select each digit to be changed. Use the up and down arrow keys to change the value. When finished, press **Enter**. The screen returns to the Clock Menu.

4.5.5 Resetting the Year

```
Thu 1/15/2009 08:39
-----
Hour      Year
Minutes
Month
Date
```

To reset the year, from the Clock Menu select Year and press **Enter**. The following screen appears.

```
Set Year:
-----
Max: 2100
 2009
 ^
Min: 2008
√=Save X=Cancel
```

Use the left and right arrow keys to select each digit to be changed. Use the up and down arrow keys to change the value. When finished, press **Enter**. The screen returns to the Clock Menu.

4.6 Pressure Settings



To reset the pressure settings, from the Settings Menu, select Pressure... and press **Enter**. The following screen appears.

4.6.1 Setting Pressure Units

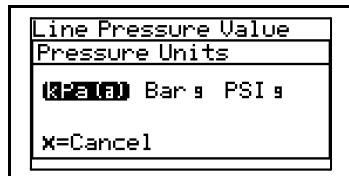

To set the pressure units, from the Pressure Menu, select Units and press **Enter**. You can then choose from: kPa(a) (Kilopascals Absolute), Bar g- (Bars gauge), or PSI g- (Pounds per Square Inch gauge).

4.6.2 Setting the Source

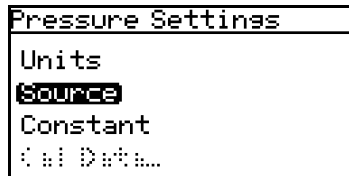

To reset the source, from the Pressure Menu, select Source and press **Enter**. The following screen appears.

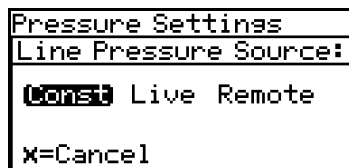

Use the left and right arrow keys to select the line pressure source. **Live** accepts a pressure value from a pressure transmitter and **Remote** accepts a value via a Modbus connection. To set a constant value, select Constant and press **Enter**. The screen returns to the Pressure Menu.

4.6.3 Changing the Constant

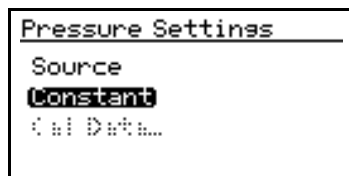

If the pressure source selected is Constant, to reset its value, select Constant from the Pressure Menu and press **Enter**. The following screen appears.

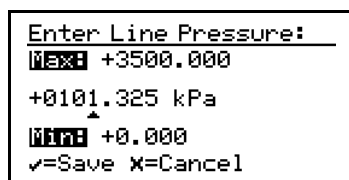

Use the left and right arrow keys to select each digit to be changed. Use the up and down arrow keys to change the value. When finished, press **Enter**. The screen returns to the Pressure Menu.

Note: Data entry for this setting is in the units selected in Section 4.6 above.

4.6.4 Editing Pressure Calibration

Pressure input in this section is used only for equivalent dew point calculations. Equivalent dew point is the dew point of the process gas at the process pressure. Input a "constant" value if the line pressure is at a normal pressure, or use an external pressure transmitter to input a "live" pressure input into the **Aurora H2O** analyzer.

```

Pressure Settings
Line Pressure Source:
Constant Live
X=Cancel
  
```

To edit the pressure calibration, from the Line Pressure Source Menu, select Live and press **Enter**. The following screen appears.

```

Line Pressure Value
Source
Constant
Cal Data
  
```

To edit the Calibration Data, use the arrow keys to select Cal Data and press **Enter**. The following screen appears.

```

Edit Pressure Cal
Select Cal Point
Edit Pressure Value
Edit Input Value
  
```

To select the Calibration Point, use the up and down arrow keys to highlight Select Cal Point and press **Enter**. The following screen appears.

```

Edit Pressure Cal
Select Cal Point:
Zero Span
X=Cancel
  
```

Use the left and right arrow keys to select Zero or Span and press **Enter**. The screen returns to the previous menu.

```

Live Pressure Zero
Select Cal Point
Edit Pressure Value
Edit Input Value
  
```

To edit the Pressure Value, use the up and down arrow keys to select Edit Pressure Value and press **Enter**. The following screen appears.

```

Enter Line Pressure:
MAX: +3500.000
+0000.000 kPa
Min: +0.000
v=Save x=Cancel
  
```

Use the left and right arrow keys to select each digit to be changed. Use the up and down arrow keys to change the value. When finished, press **Enter**. The screen returns to the previous menu.

```

Live Pressure Zero
Select Cal Point
Edit Pressure Value
Edit Input Value
  
```

To edit the Input Value, use the up and down arrow keys to select Edit Input Value and press **Enter**. The following screen appears.

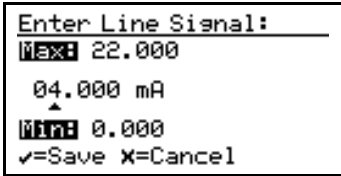

Use the left and right arrow keys to select each digit to be changed. Use the up and down arrow keys to change the value. When finished, press **Enter**. The screen returns to the previous menu.

4.7 Regional Settings

This section enables the setting of regional information, depending on the location of the **Aurora H2O**.



To reset the regional settings, from the Settings Menu, select **Locale...** and press **Enter**. The following screen appears.

Note: *Locale settings for your order have been set at the factory and are access code protected. If you determine a need to access Regional Settings, contact the factory for assistance.*

4.7.1 Setting the Country Code

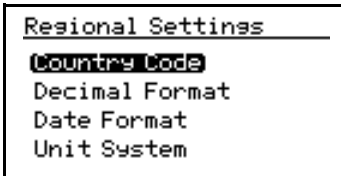

To edit the country code, from the Regional Settings Menu select **Country Code** and press **Enter**. The following screen appears. A passcode is required to make changes.

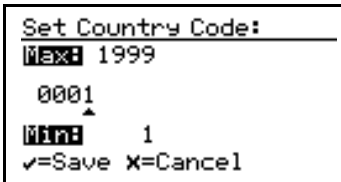

Use the left and right arrow keys to select each digit to be changed. Use the up and down arrow keys to change the value. When finished, press **Enter**. The screen returns to the Regional Settings Menu.

- **Country Codes** = international telephone country codes.
- **Default** = 1 for U.S.
- **Option** = 81 for Japan is available to conform to METI requirements.

4.7.2 Setting the Decimal Format

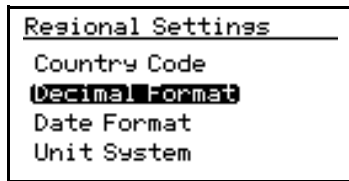

The Decimal Format option determines whether a decimal [.] or a comma [,] is used as the decimal separator. To edit the decimal format, from the Regional Settings Menu select Decimal Format and press **Enter**. The following screen appears.

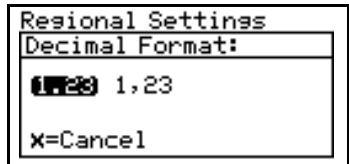

Use the left and right arrow keys to select a decimal [.] or a comma [,] as the decimal separator and press **Enter**. The screen returns to the Display Menu.

4.7.3 Setting the Date Format

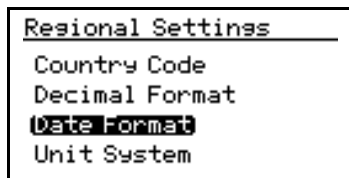

To edit the date format, from the Regional Settings Menu select Date Format and press **Enter**. The following screen appears.

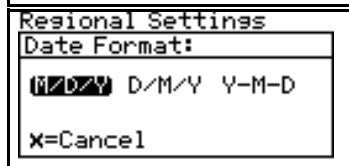

Use the left and right arrow keys to select the desired date format and press Enter. The screen returns to the previous display.

4.7.4 Setting the Unit System

IMPORTANT: If the Country Code (see “Setting the Country Code” on page 67) has been set to 81 (Japan) the Unit System menu is not available.

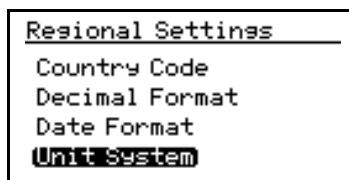

To select the unit system to be used for measurements, select Unit System and press **Enter**. The following screen appears.

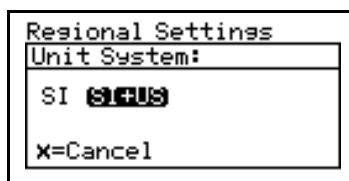

Use the left and right arrow keys to select the Unit System desired [SI = only metric units are available in the selection menus; SI + US = both metric and English units are available in the selection menus] and press **Enter**. The screen returns to the Regional Settings Menu.

Note: Changing the Unit System setting from **SI+US** to **SI** in the above menu will **NOT** immediately change the current Display or Outputs units. This is because it is not possible for the **Aurora H2O** to know the **SI** measurement units desired by the operator to replace any currently displayed or output English units. However, the next time the operator selects different Display (see “Selecting Primary Units” on page 40) or Outputs (see “Selecting Output Units” on page 43) units, only **SI** units will be available in the menu.

4.8 User Calibration

Beginning with software revision H2O.001.F, the **Aurora H2O** supports a two-point User Calibration for use in methane/natural gas. This is provided so that a field calibration can be easily performed to cause the **Aurora H2O** measurement to correspond to a calibration gas or other moisture device. The User Calibration is independent from, and does not affect, the Factory Calibration. The **Aurora H2O** can be quickly switched between User and Factory calibration at any time.

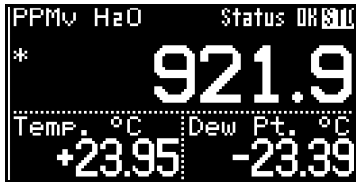

When a User Calibration is active, an asterisk (*) will appear in the upper left corner of the primary display.

Before the calibration can be performed, the **Aurora H2O** must be operating correctly in methane or natural gas, with methane selected as the Background Gas.

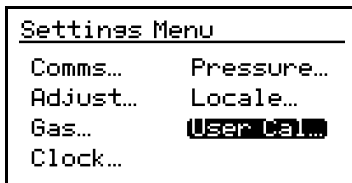

Choose Settings... from the Main Menu. A User Cal... selection is now provided.

Note: If the **Aurora H2O** is set for Nitrogen as the background gas, the **User Cal** selection will be disabled/grayed out.

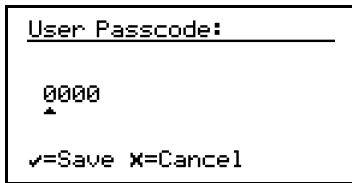

The **Aurora H2O** will prompt for the User Passcode [2719]

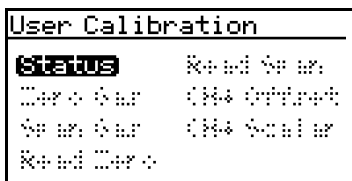

By default, the **Aurora H2O** is operating with the Factory calibration, so the User Calibration Menu is disabled with the exception of the Status selection.

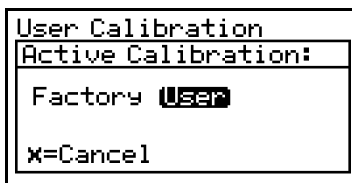

Select Status, and choose User as the Active Calibration.

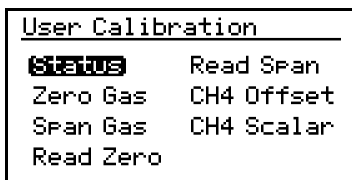

The User Calibration Menu is now enabled.

The selections on the User Calibration Menu include the following functions:

Item	Purpose
Zero Gas	User specifies the water concentration, in PPMv, of the "Zero", or dry gas.
Span Gas	User specifies the water concentration, in PPMv, of the "Span", or Cal/Wet gas.
Read Zero	The Aurora H2O will read the signal while exposed to the Zero gas.
Read Span	The Aurora H2O will read the signal while exposed to the Span gas, then determine the CH4 Offset and Scalar calibration values.
CH4 Offset	Permits the user to view/edit the calculated offset term.
CH4 Scalar	Permits the user to view/edit the calculated scalar (gain) term.

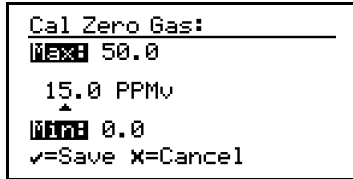

First select the Zero Gas and Span Gas items, to specify the cal gases to be used. The zero gas must be in the range of 0.0 to 50.0 PPMv water. It is recommended that the zero gas be 10.0 PPMv or higher for best results. The Span gas must be in the range of 0.0 to 5000.0 PPMv water. It is recommended that the Span gas be 500.0 PPMv or lower for best performance.

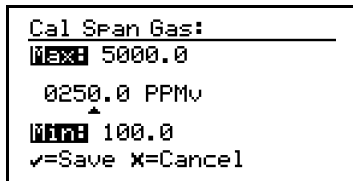

Apply the Zero gas, and wait for the **Aurora H2O** reading to stabilize.

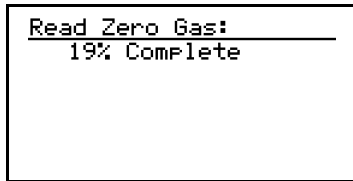

Note: The user can exit to the display and return to the User Cal Menu without affecting the Calibration procedure.

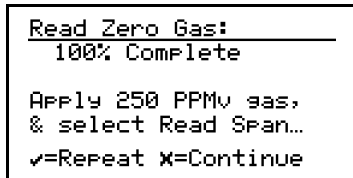

When the reading is stable, select **Read Zero**. The **Aurora H2O** performs multiple measurements for approximately 15 seconds, indicating its progress. When the readings are complete, you will be prompted to apply the span gas, and continue. If there is doubt about the stability of the zero gas, the reading can be repeated at this point.

Apply the Span gas, and wait for the **Aurora H2O** reading to stabilize.

When the reading is stable, select Read Span. The **Aurora H2O** uses the current measurement, and immediately calculates the new calibration. If the calculated values are determined to be valid, the **Aurora H2O** will display "Calibration OK" and prompt you to Save the results, or Cancel. If the values are not valid, the Aurora will display "Calibration *FAILED*", and prompt you to continue. On a cal failure or Cancel, no change is made to the User Calibration values.

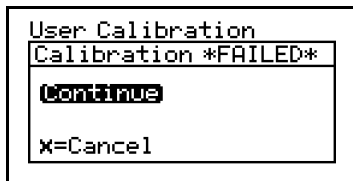

The CH4 Offset and CH4 Scalar items can be used to view or modify the calculated calibration points, if desired.

Note: The default values for the CH4 Offset is 0.0 and the CH4 Scalar is 1.0. These defaults are NOT the same as the Factory Calibration! Making the User Cal active without performing the actual calibration will adversely affect the accuracy of the **Aurora H2O**. If there is any doubt about the quality/accuracy of the gases used, the **Aurora H2O** should be returned to the Factory calibration using the Status item.

4.9 Service Settings



CAUTION! The *Service Settings Menu* should be used by factory-trained personnel only.

4.10 Aurora H2O Information

```
Main Menu
-----
Display...  Service...
Outputs...  About...
Alarm...    LOCK
Settings...
```

To check the **Aurora H2O** information, from the Main Menu select About and press **Enter**. The following screen appears.

4.10.1 Checking the ID

```
About Aurora
-----
ID
System Status
Software Versions
Gas Composition
```

To check identification information, select ID and press **Enter**. A screen similar to the following appears.

```
Menu:X
-----
GE Aurora/H2O
Copyright © 2008-15
General Electric Co.
Unit SN: 1518
Laser SN: 1455/5-6
```

To return to the About Menu, press **Enter**.

4.10.2 Checking the System Status

```
About Aurora
-----
ID
System Status
Software Versions
Gas Composition
```

To view the status of the **Aurora H2O** system, from the About Menu select System Status and press **Enter**. A screen similar to the following appears.

```
Menu:X
-----
Uptime: 0d 00h
Started: 5/11/2009 14:07
Start Temp: 24.32 °C
Laser Hours: 1399
```

Uptime: is the elapsed time since the **Aurora H2O** was powered on or reset.
Started: is the date and time that the **Aurora H2O** was last powered on/reset.
Start Temp: is the laser housing temperature as measured at the last startup/reset.
Laser Hours: indicates the total lifetime that the laser has been energized.

To return to the About Menu, press **Enter**.

4.10.3 Checking the Software

```

About Aurora
-----
ID
System Status
Software Versions
Gas Composition
  
```

To view the software versions being used, from the About Menu select Software Versions and press **Enter**. A screen similar to the following appears.

```

Menu: X
BOOT: 1.C
PROG: H2O.196.A
  
```

To return to the About Menu, press **Enter**.

4.10.4 Checking the Gas Composition

```

About Aurora
-----
ID
System Status
Software Versions
Gas Composition
  
```

To view the gas content, from the About Menu select Gas Composition and press **Enter**. A screen similar to the following appears.

```

Menu: X
Gas: STD
    CH4: 90.0%
    N2: 10.0%
  
```

To return to the About Menu, press **Enter**.

4.10.5 Checking the Alternate Gas Composition

The **Aurora H2O** TDLAS is normally calibrated to a standard gas mixture that is representative of “typical” natural gas. The primary components and concentrations of this gas mixture are as follows:

Component	Concentration
Methane (CH ₄)	90.0%
Nitrogen (N ₂)	10.0%

For special applications, where the composition of the gas to be measured differs significantly from the standard, Panametrics can provide an alternate calibration. If this service has been ordered, the **Aurora H2O** will be shipped from the factory with both the standard and a custom calibration installed.

Main Menu	
Display...	Service...
Outputs...	ABOUT...
Alarm...	LOCK
Settings...	

The calibration in use can be verified at any time using the **Aurora H2O** About... menu. From the Main Menu, select About and press **Enter**. The following screen appears.

About Aurora	
ID	
System Status	
Software Versions	
Gas Composition	

From the About Aurora menu, select Gas Composition and press **Enter**. The following screen appears.

An identifier label for the gas composition will be displayed above the components:

Menu: X	
Gas:	STD
CH ₄ :	90.0%
N ₂ :	10.0%

Gas Composition Identifier

4.11 Locking/Unlocking the Display

Main Menu	
Display...	Service...
Outputs...	About...
Alarm...	LOCK
Settings...	

To lock the **Aurora H2O** against any future changes, from the Main Menu select Lock and press **Enter**. The screen returns to the standard display.

Note: This menu option is the same as exiting the programming menu and waiting for a keypad time-out to lock the keypad.

PPMv H ₂ O	Status OK STD
175.8	
Temp. °C	Sample PSIa
+23.5	14.813

To unlock the **Aurora H2O** for changes, press **Cancel, Enter, Cancel** as instructed in “Unlocking the Keypad” on page 38.

[no content intended for this page]

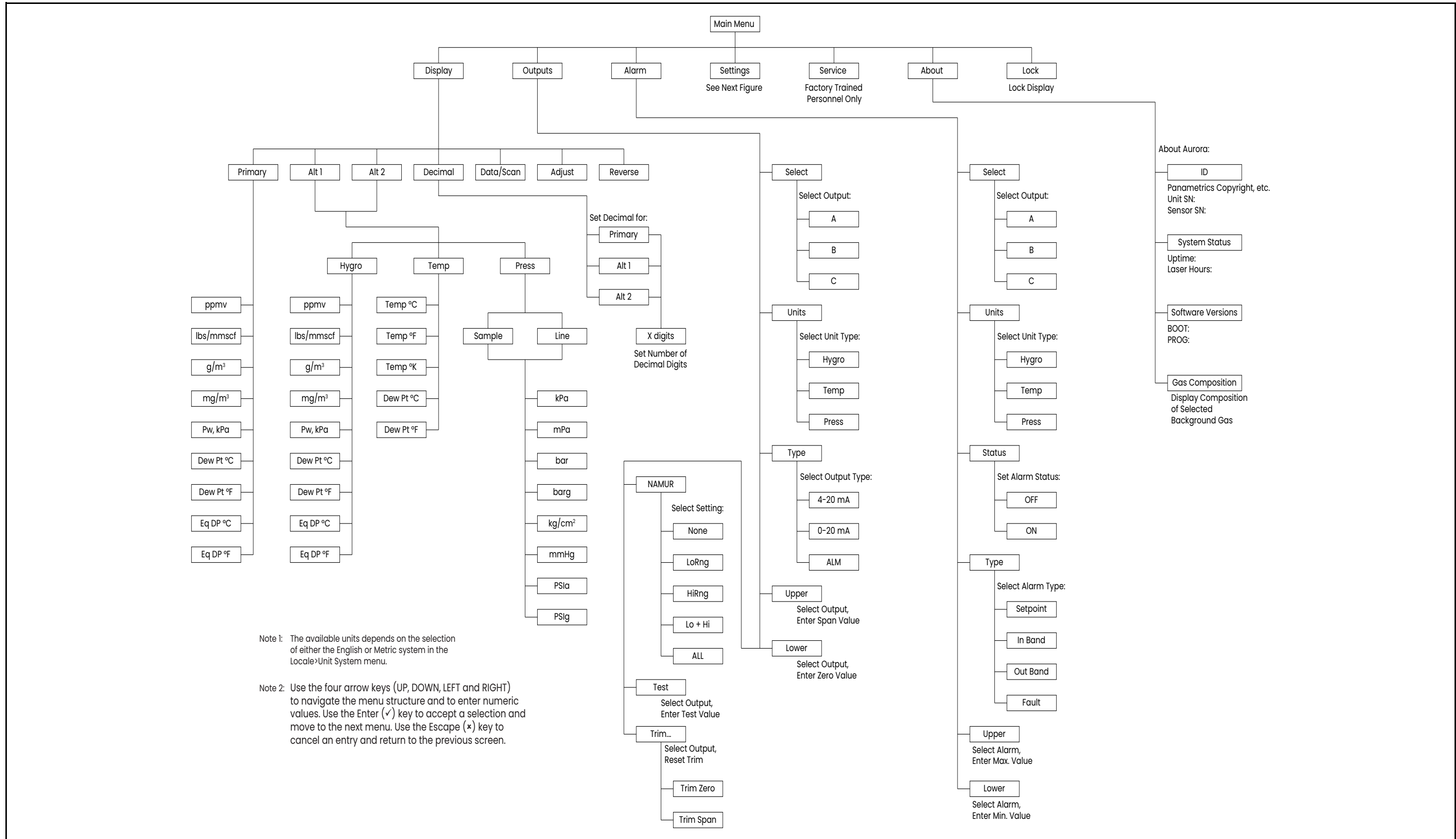
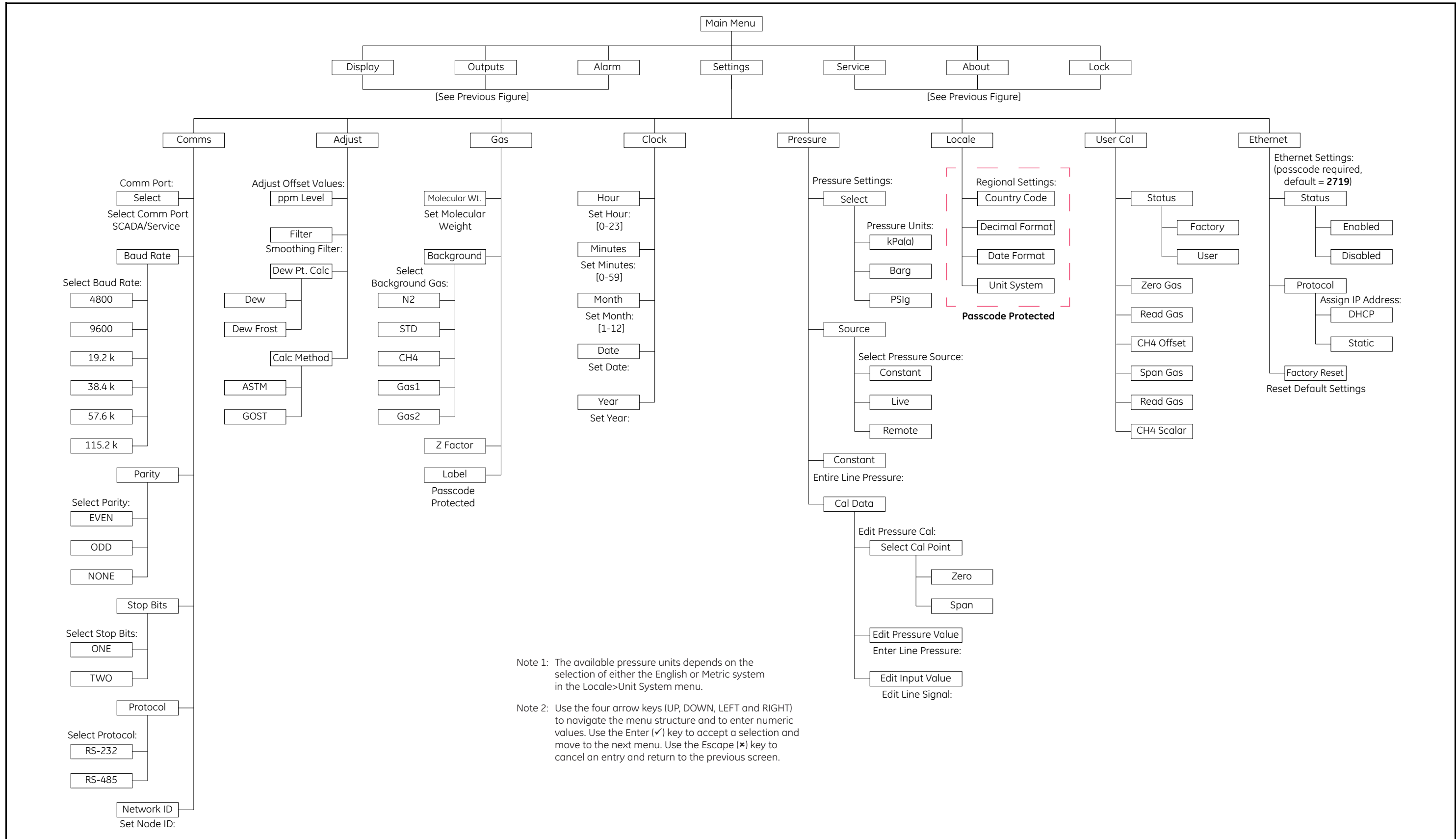

Figure 49: Display, Outputs, Alarm, Service, About and Lock Menu Map



Note 1: The available pressure units depends on the selection of either the English or Metric system in the Locale>Unit System menu.

Note 2: Use the four arrow keys (UP, DOWN, LEFT and RIGHT) to navigate the menu structure and to enter numeric values. Use the Enter (✓) key to accept a selection and move to the next menu. Use the Escape (✖) key to cancel an entry and return to the previous screen.

Figure 50: Settings Menu Map

Chapter 5. AuroraView Interface Software

5.1 Capabilities

Your **Aurora H2O** Analyzer is shipped with a CD which includes a PC-Software Application called **AuroraView**. With **AuroraView**, you can:

- View **Aurora H2O** Configuration Items such as Alarms & Outputs.
- Use the DataLog function to copy data to a comma delimited .txt file which can be opened by spreadsheet applications such as Microsoft Excel.
- Plot real-time data for one or more **Aurora H2O** parameters
- Manipulate plotted data in a variety of ways such as: color, line type, zoom in/out, etc.
- Trend tabular data in real-time.
- Show Scan Plots of the moisture absorption spectra.
- Copy plots from **AuroraView** to other Window applications like Microsoft Powerpoint or Word.

AuroraView does not provide functionality for the following:

- **Aurora H2O** software updates.
- Save the **Aurora H2O** Configuration. The **Aurora H2O** has a robust design which allows the meter to recover from fault conditions without the need to upload the configuration of the meter using external software.

5.2 Requirements

AuroraView leverages a *National Instruments Run-Time* environment. This environment is supported on the following operating systems with the minimum installation requirements indicated:

- Windows XP (SP3), Windows7, Windows 8.1 or Windows 10
- 260 MB of available hard disk space
- 64 MB of RAM or more
- 300 MHz Pentium CPU
- Internet Explorer v5.0 or higher

AuroraView supports the following serial interfaces:

- RS232
- RS485 Modbus
- Modbus/TCP via Ethernet

5.3 Installing AuroraView

1. Insert the *Installation CD* into the optical drive on your PC.
2. The installation program should launch automatically (see *Figure 51* below). If it does not, select Start → Run → Browse.

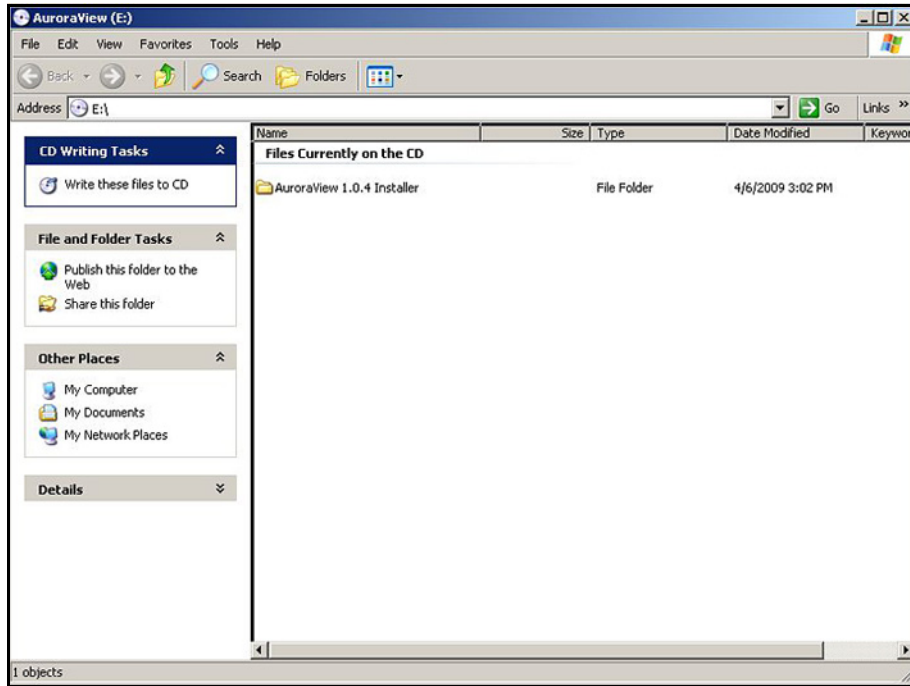

Figure 51: Initial Screen

- Browse to the file named "setup.exe" in the root directory of the CD (see Figure 52 below). Double-click the file to start the installation.

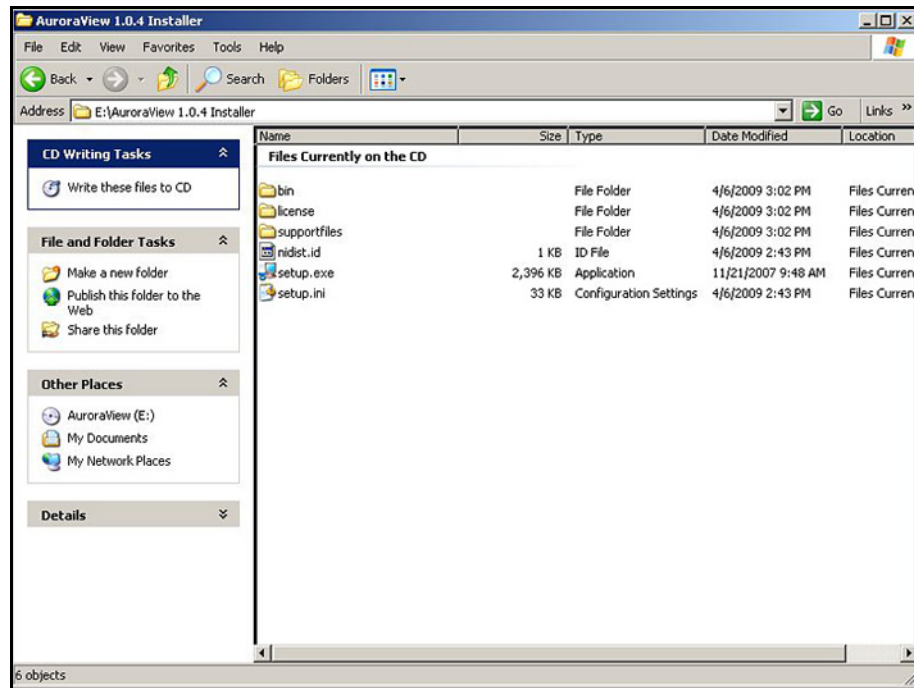

Figure 52: AuroraView Installer

4. Exit all other programs before running the installer (see *Figure 53* below).

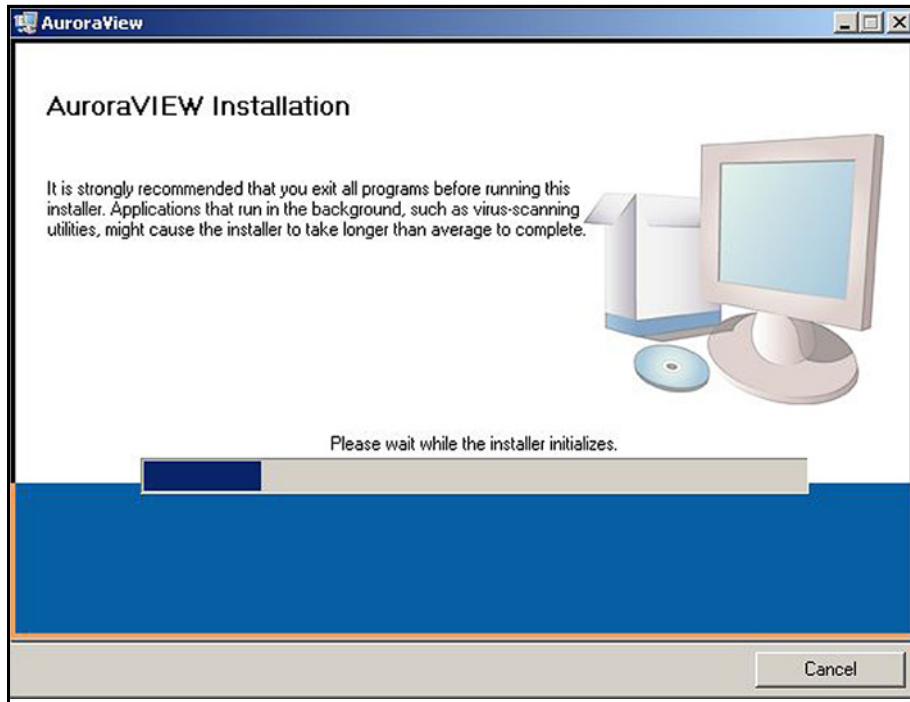

Figure 53: Installation Recommendation

5. The next screen (see *Figure 55* below) provides the opportunity to change installation locations if desired. When ready, click **Next**.

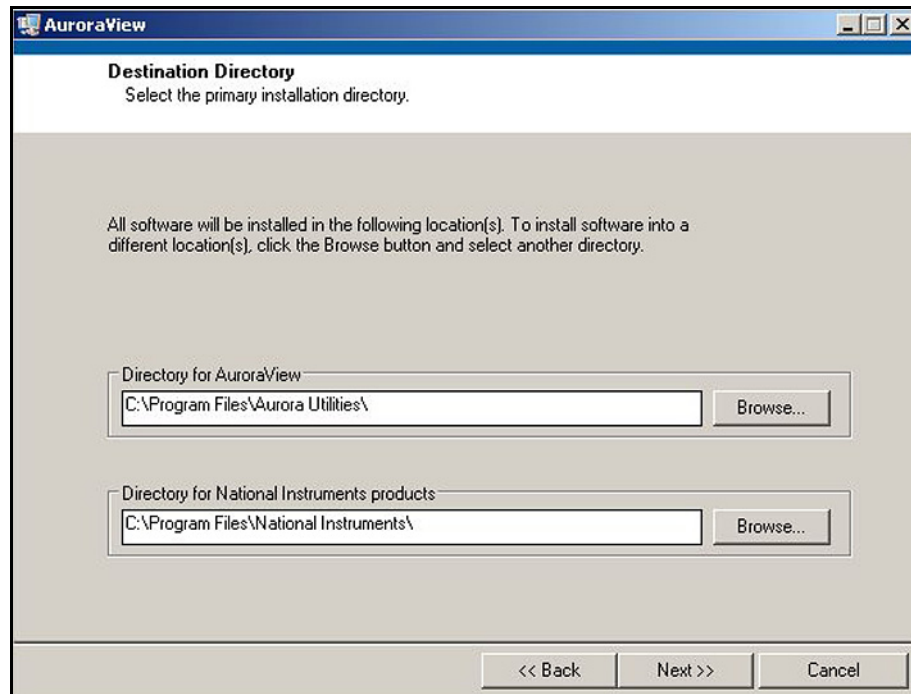

Figure 54: Destination Directory

6. At the next screen, accept the *Software License Agreement* (see *Figure 55* below) and click **Next**.

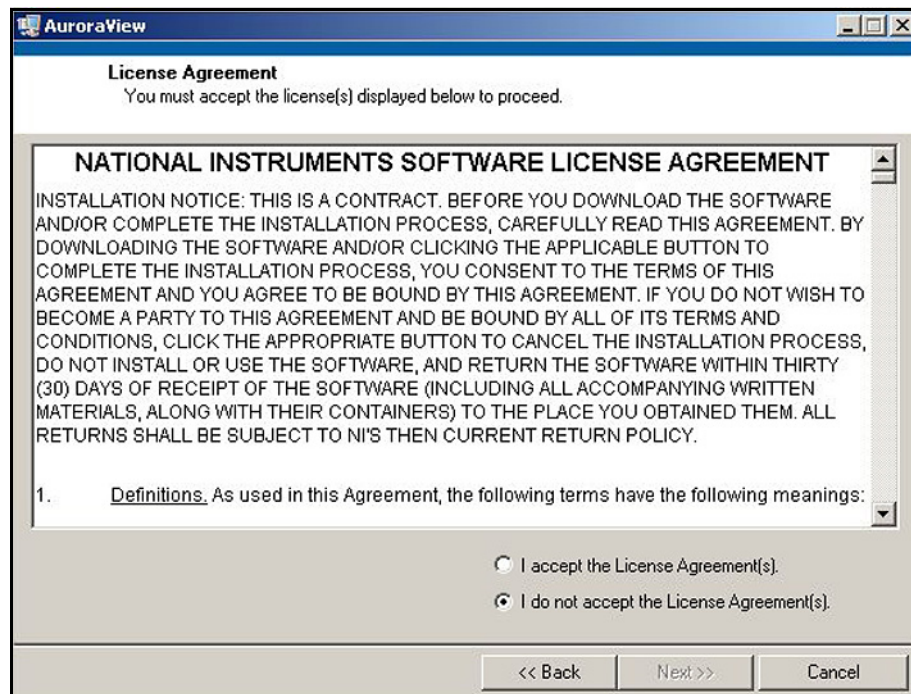

Figure 55: Software License Agreement

7. The next screen (see *Figure 56* below) provides instructions for initiating the installation. When ready, click Next to begin.

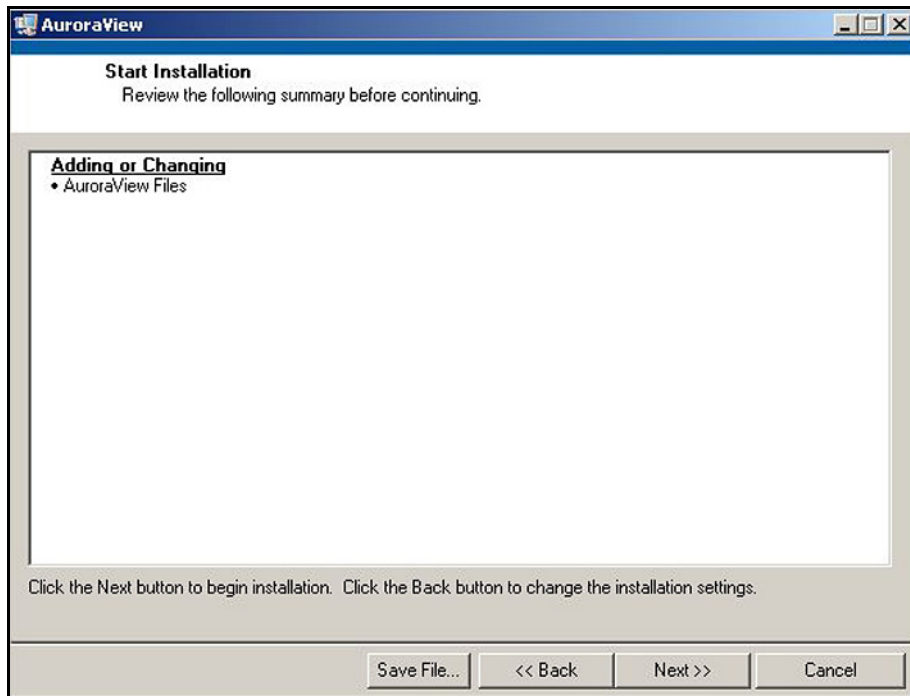

Figure 56: Starting the Installation

8. During installation, the screen shown in *Figure 57* below appears.

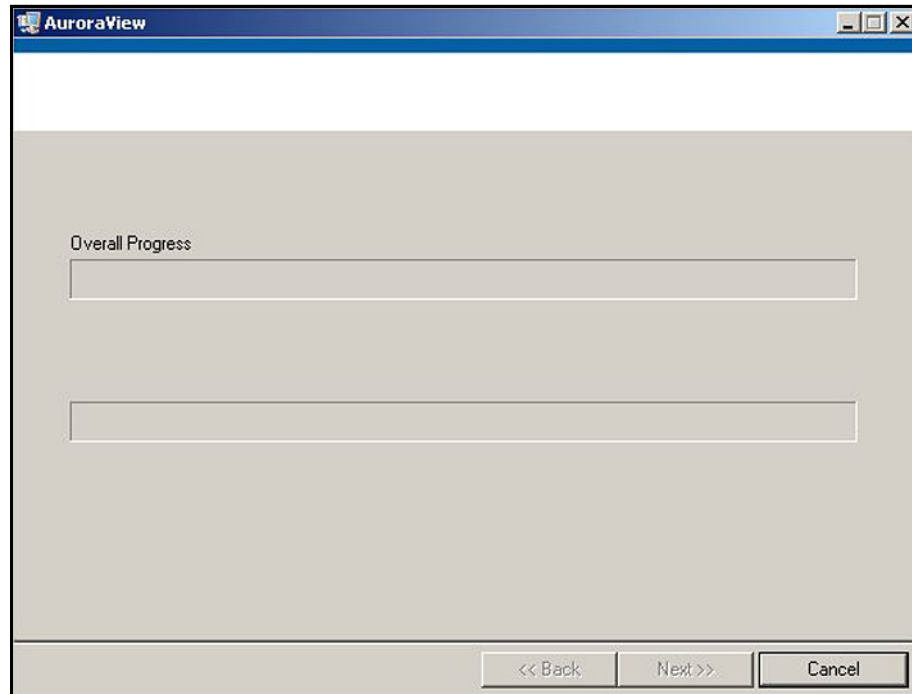

Figure 57: Overall Progress

9. The screen shown in *Figure 58* below appears when the installation is complete.

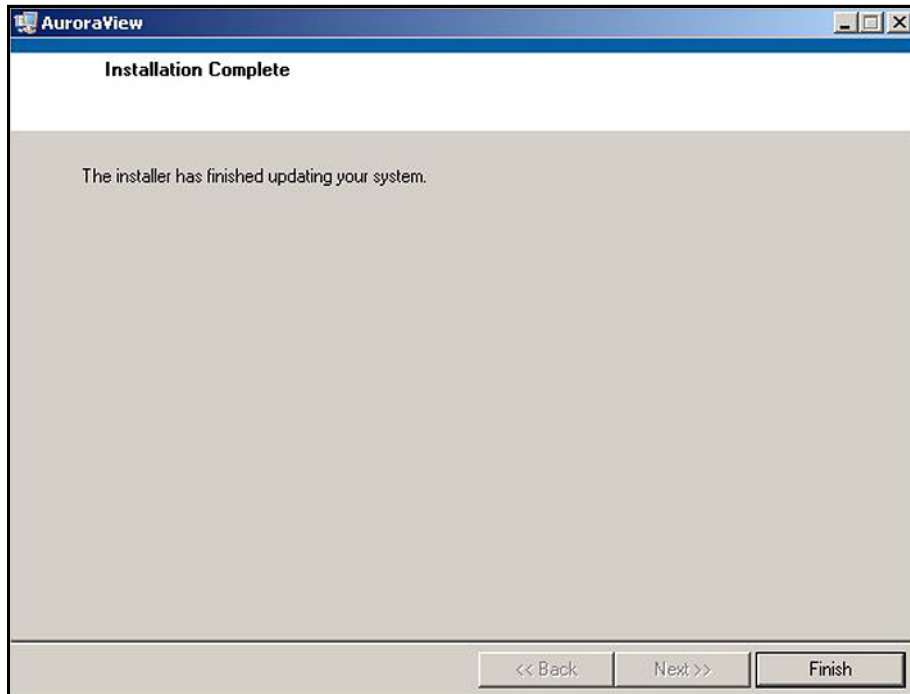

Figure 58: Installation Is Complete

5.4 Starting AuroraView

1. From the Start menu, click Programs → AuroraView → AuroraView (see *Figure 59* below).

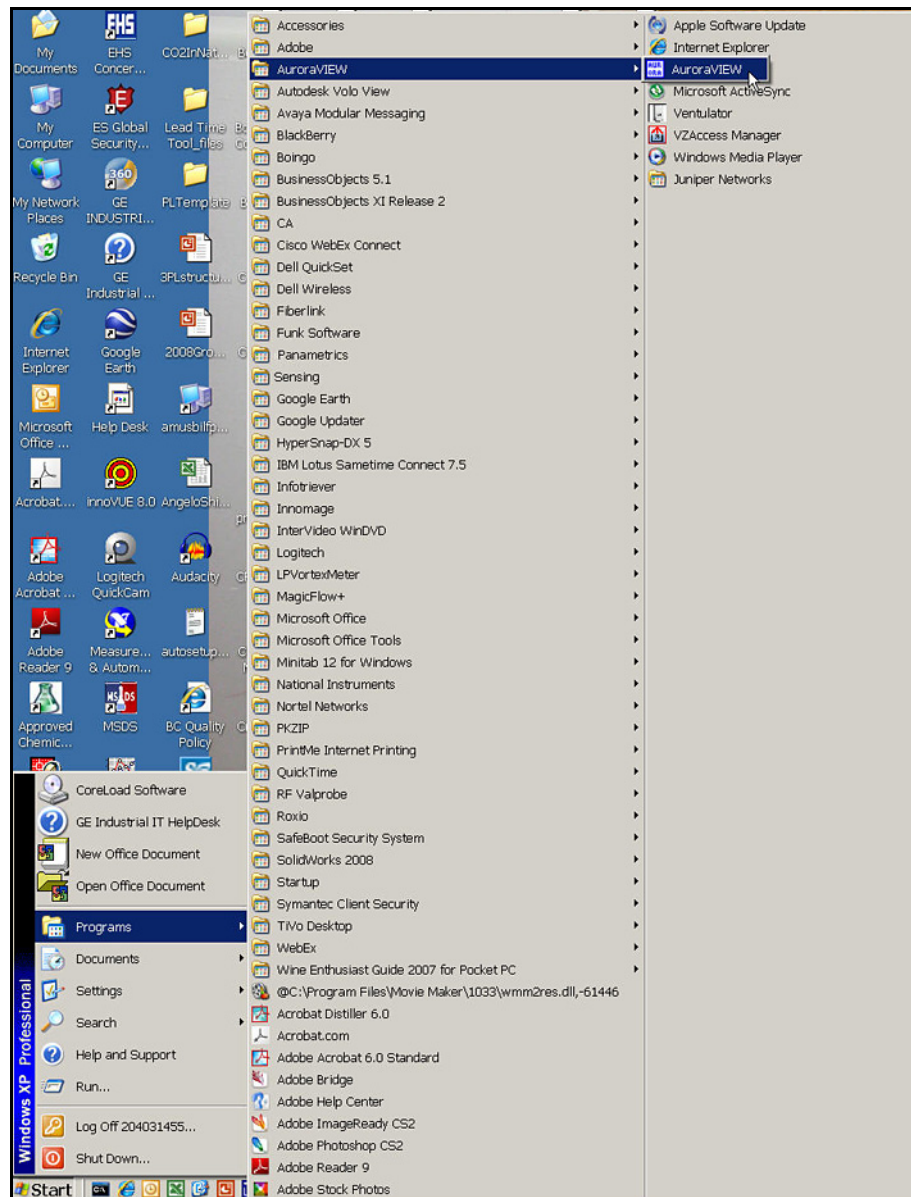

Figure 59: AuroraView in Programs Menu

5.4 Starting AuroraView (cont.)

2. AuroraView boots up and displays a screen similar to *Figure 60* below.

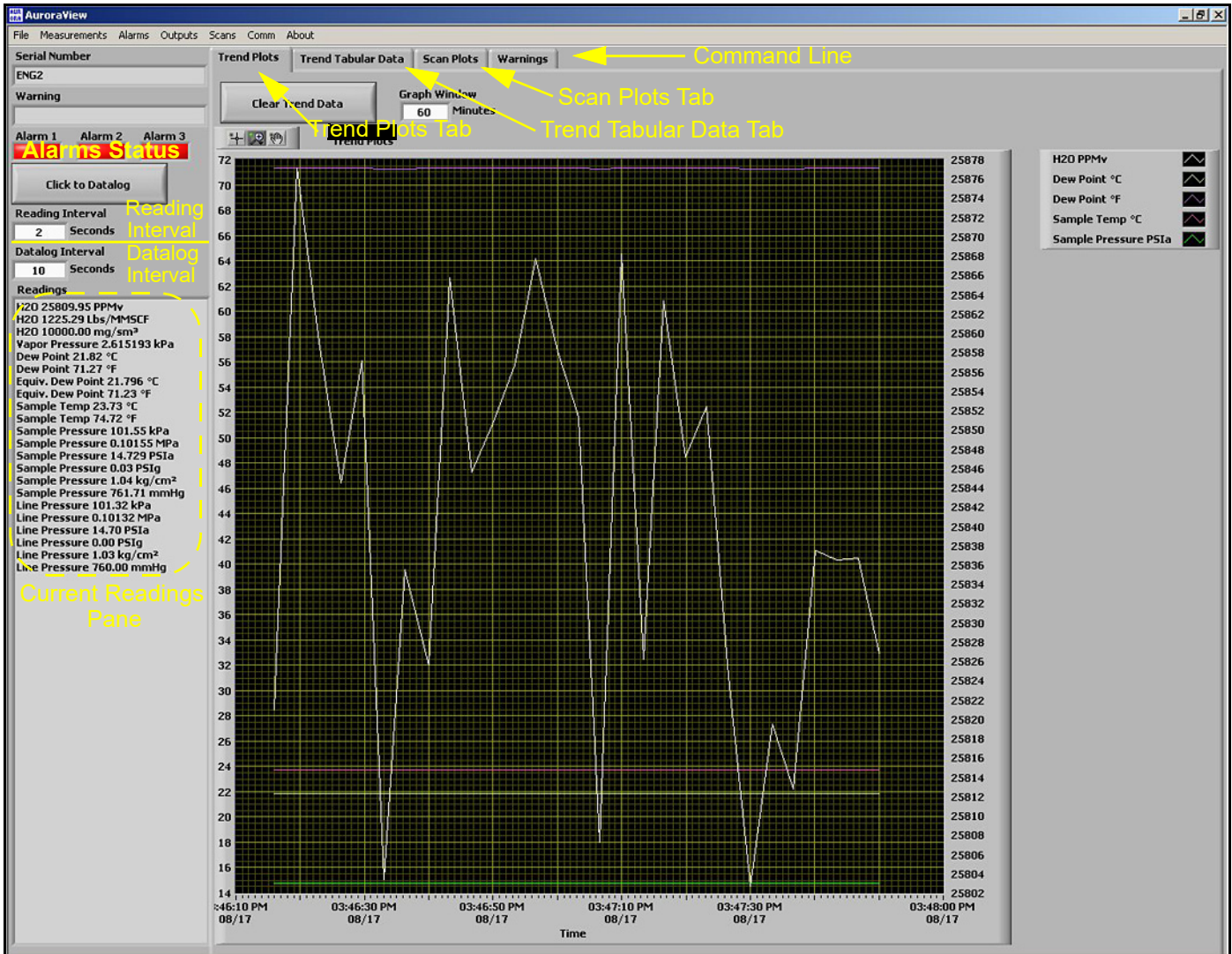

Figure 60: AuroraView Main Screen

5.5 Using the Main Menu

1. Click Measurements → Config (see *Figure 61* below).

Measurement	Displayed As	Unit String	Digits Of Precision	Read	Plot	Datalog	Use Second Axis
Volume_Ratio_PPMv	Volume Ratio	PPMv	1	<input checked="" type="checkbox"/>	<input checked="" type="checkbox"/>	<input checked="" type="checkbox"/>	<input checked="" type="checkbox"/>
Dew_Point_C	Dew Point	°C	1	<input checked="" type="checkbox"/>	<input type="checkbox"/>	<input checked="" type="checkbox"/>	<input type="checkbox"/>
Eq_Dew_Point_C	Equiv. Dew Point	°C	1	<input checked="" type="checkbox"/>	<input type="checkbox"/>	<input checked="" type="checkbox"/>	<input type="checkbox"/>
Abs_Humidity_mg_m3	Abs. Humidity	mg/sm ³	2	<input checked="" type="checkbox"/>	<input type="checkbox"/>	<input checked="" type="checkbox"/>	<input type="checkbox"/>
Volume_Ratio_PPBv	Volume Ratio	PPBv	0	<input type="checkbox"/>	<input type="checkbox"/>	<input type="checkbox"/>	<input checked="" type="checkbox"/>
Abs_Humidity_g_m3	Abs. Humidity	g/sm ³	2	<input type="checkbox"/>	<input type="checkbox"/>	<input type="checkbox"/>	<input type="checkbox"/>
Abs_Humidity_kg_m3	Abs. Humidity	kg/sm ³	2	<input type="checkbox"/>	<input type="checkbox"/>	<input type="checkbox"/>	<input type="checkbox"/>
Abs_Humidity_Lbs_MMSCF	Abs. Humidity	Lbs/MMSCF	2	<input checked="" type="checkbox"/>	<input type="checkbox"/>	<input checked="" type="checkbox"/>	<input type="checkbox"/>
Pw_kPa	Vapor Pressure	kPa	5	<input checked="" type="checkbox"/>	<input type="checkbox"/>	<input checked="" type="checkbox"/>	<input type="checkbox"/>
Dew_Point_F	Dew Point	°F	1	<input type="checkbox"/>	<input type="checkbox"/>	<input type="checkbox"/>	<input type="checkbox"/>
Eq_Dew_Point_F	Equiv. Dew Point	°F	1	<input type="checkbox"/>	<input type="checkbox"/>	<input type="checkbox"/>	<input type="checkbox"/>
Eq_Dew_Point_70_bar_C	Dew Point @ 70 bar	°C	1	<input type="checkbox"/>	<input type="checkbox"/>	<input type="checkbox"/>	<input type="checkbox"/>

Figure 61: Configure Measurements Screen

- Unit String: Set this value to the value you want to read, plot or datalog.
- Digits of Precision: Set a numerical value (typically 0, 1, 2). This sets the resolution of the displayed measurement units to the right of the decimal place (i.e., "20.78" would result from a setting of "2").
- Read: Check this box if you want to show the value in the current Readings pane.
- Plot: Check this box if you want to show the value in the Trend Plots graph AND the Trend Tabular Data tab.

2. Click Alarms → Config

This window enables the user to configure the alarm status within the **AuroraView** application. This feature allows you to remotely configure **Aurora H2O** alarms, which are used only with Modbus RTU digital output. The **AuroraView** Alarms are shown in *Figure 62*, *Figure 63* and *Figure 64* below.



Figure 62: Alarms Configuration

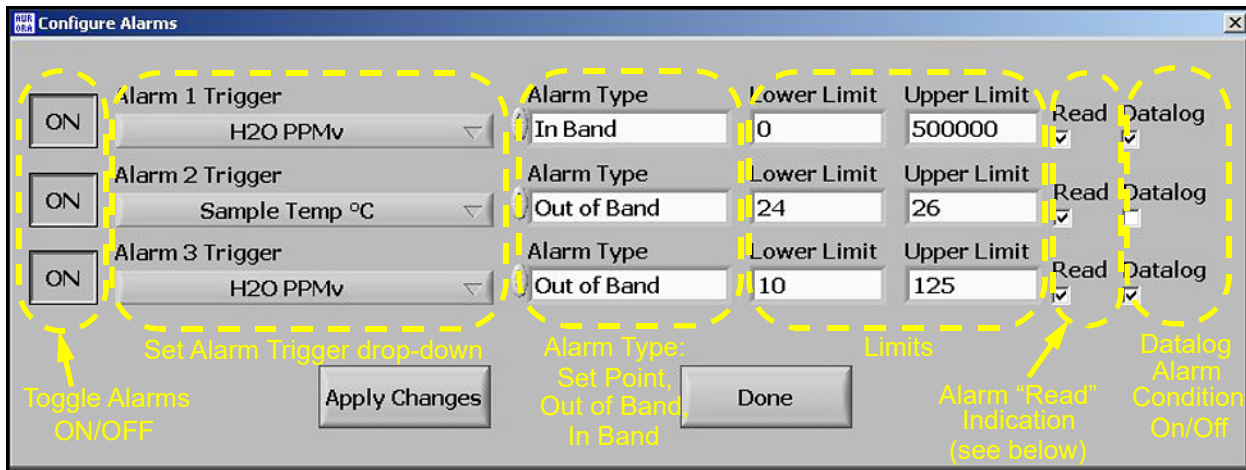

Figure 63: Other Measurements Options



Figure 64: Alarm Status Indicators

3. Click Outputs → Config (see *Figure 65* and *Figure 66* below).



Figure 65: Outputs Configuration

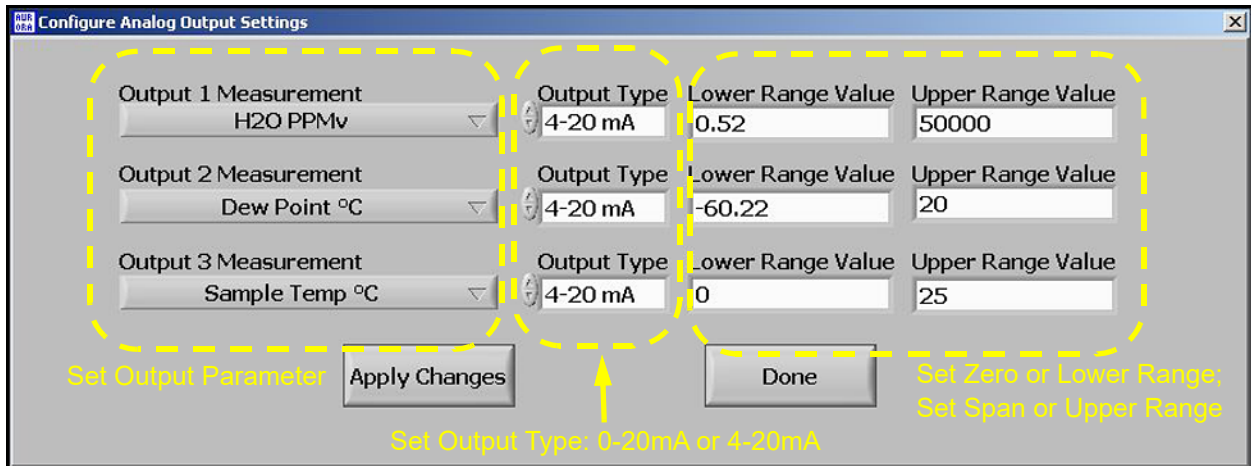

Figure 66: Other Output Options

4. Click Scan

This section enables you to pick the desired type of scan. The default scan is the SPECTRA scan, which shows the 2f spectral scan. This is the processed signal waveform that the **Aurora H2O** uses to determine the moisture concentration. Viewing this scan may assist in troubleshooting. A typical 2f spectra scan is shown in *Figure 68* below. Select the scan interval in minutes to set the refresh rate at which AuroraView updates the scan plot. To enter a scan interval, click on the Click to Save Scans Periodically button, and the screen shown in *Figure 67* below appears. Enter the interval and click on Continue to save or Cancel to reject the change.

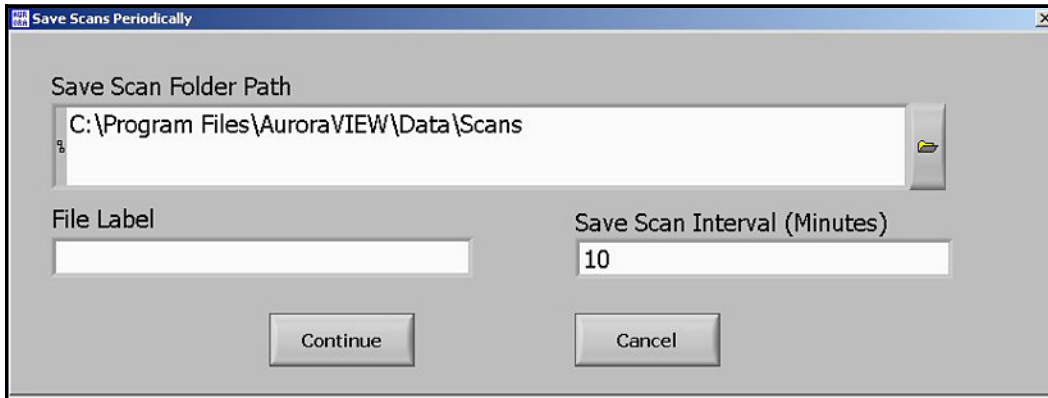

Figure 67: Save Scans Periodically

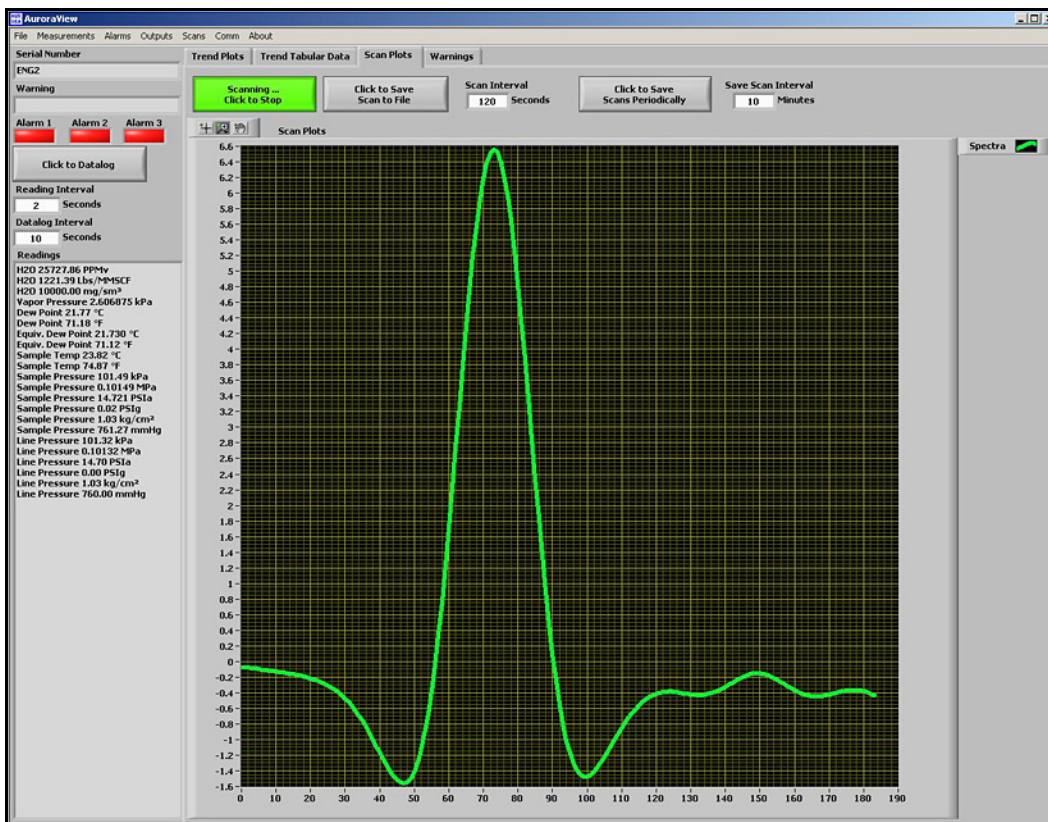

Figure 68: Scan Plot Tab

5. Click Comms

This window (see *Figure 69* below) enables you to configure communication options. Communication with the Aurora takes place over a serial ('comm') port, or via Modbus/TCP over Ethernet if the Aurora is so equipped. Choose the preferred method to use from the Modbus Interface drop down menu:

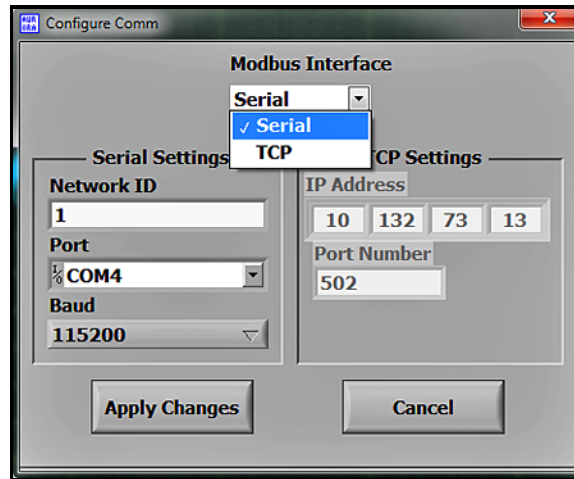

Figure 69: Configure Communication Options

For **Serial** (see *Figure 70* below), choose the comm port to use from the list of available ports. By default, AuroraView specifies 115200 bps, 8 data bits, even parity, and 1 stop-bit, which is also the default in the Aurora. If you have more than one Aurora H2O on an RS485 network, you will have to establish a different **NETWORK ID** for each analyzer, using the keypad on the Aurora H2O.

For **TCP** (see *Figure 70* below), specify the IP address of the Aurora, as described in "IP Address Assignment" on page 55. Unless required by your network infrastructure, do not change the Ethernet Port value from the default of 502.

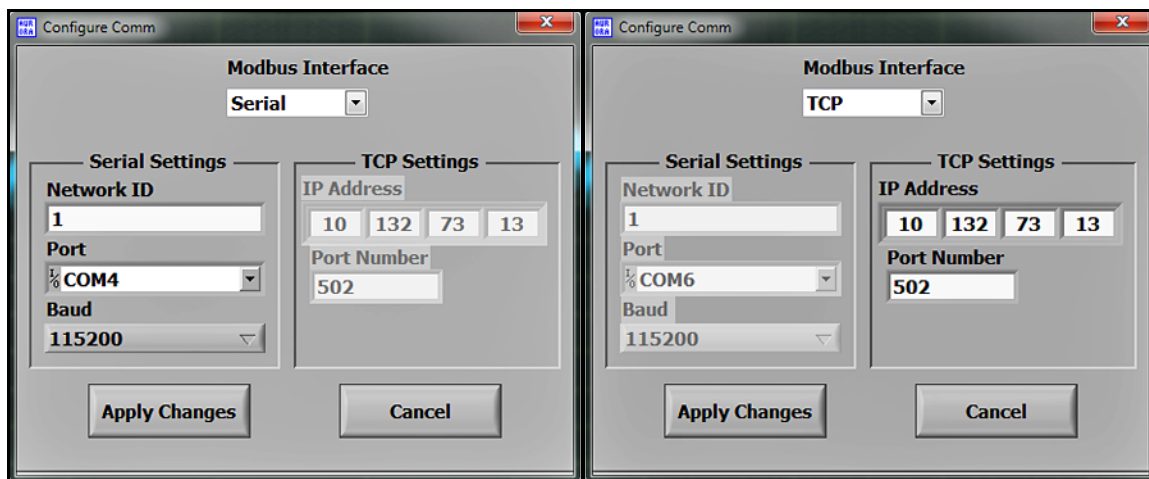

Figure 70: Serial (Left) and TCP (Right) Screens

6. Click Help (see *Figure 71* below).

This screen indicates the version of **AuroraView** currently installed.

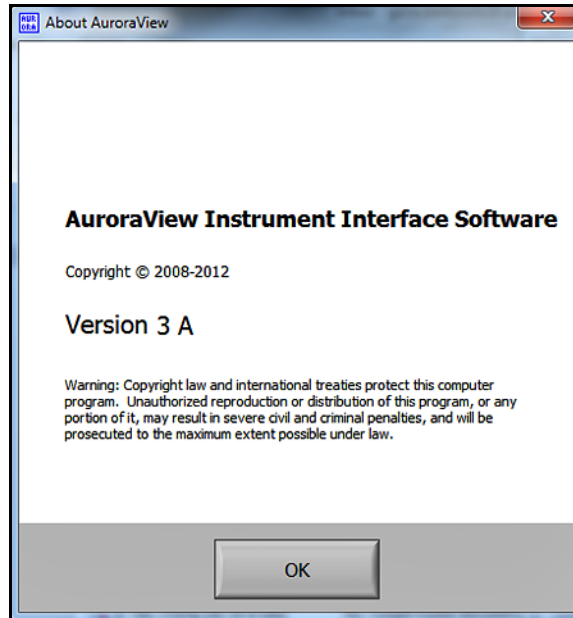

Figure 71: Software Information

5.6 Datalogging with AuroraView

1. In the main view (see Figure 72 below), click on the button Click to Datalog.

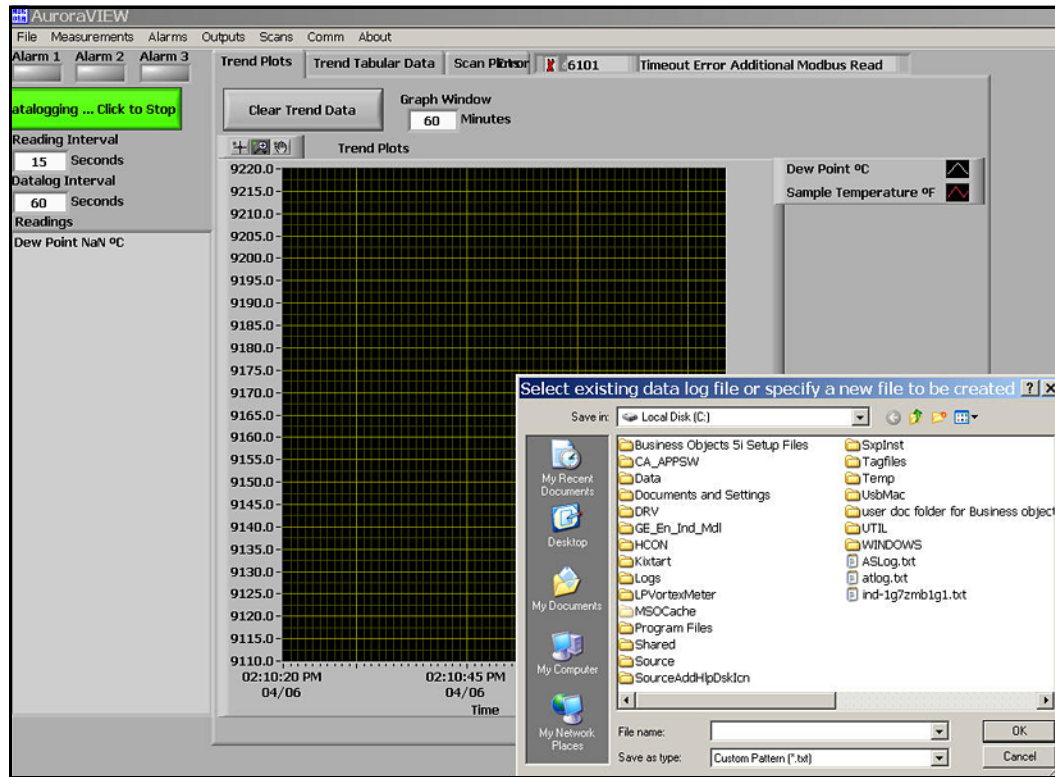

Figure 72: Datalogging with AuroraView

2. AuroraView will request a file location. Pick a file location and a file name to save your data log files. All data log files are comma delimited .txt files by default.
3. Once you pick a file location, AuroraView will write any parameter that has a check box with Datalog checked in the main Config window at the time interval set in the Datalog Interval box, and the button in the main window will change to Datalogging...Click to Stop.
4. When you are done datalogging, click the button to stop logging. You may now open your .txt datalog file in any application, such as Microsoft Excel, so that you can analyze that data.

Note: When datalogging multiple parameters at intervals of five seconds or less, it is recommended to use baud rates of 57.6K or 115.2K.

5.7 Working with Trend Plots, Trend Tabular Data and Scan Plots

1. Trend Plots is a powerful graphing feature in AuroraView. You can graph many parameters at the same time (see Figure 73 below).

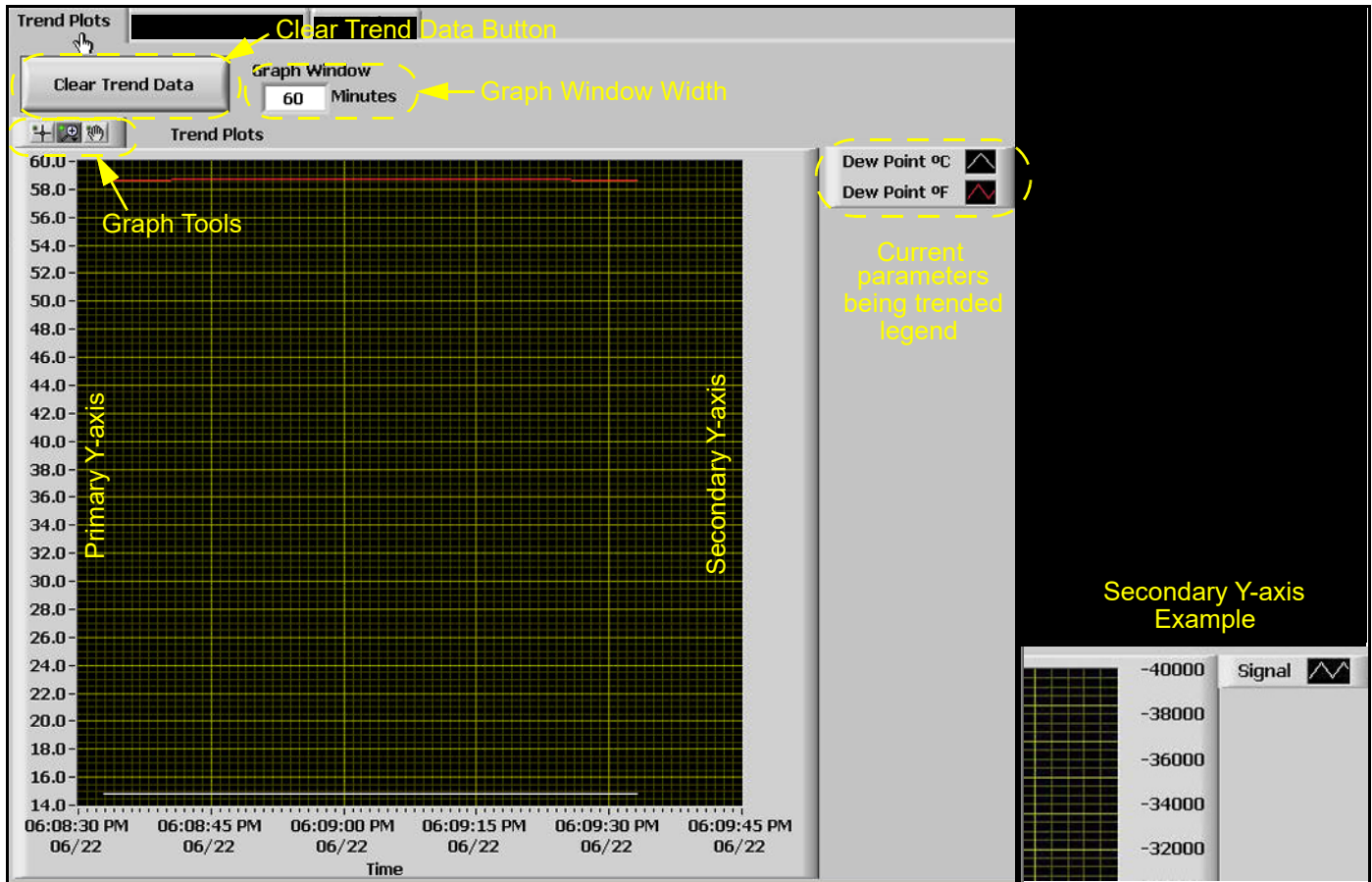

Figure 73: Using Trend Plots

Note: If you use the secondary y-axis, you may see “-” tick marks preceding the value. These are tick marks from the graphical applet and not an indication of negative values.

2. If you right-click on any series of data within the graph, or you click on the current parameter being-trended item in the legend, you will see a variety of options for graphing data (see *Figure 74* below). You can change to a variety of common plots and adjust color, line style, and line width. For some data sets with lots of finite points, you may want to click Anti-Aliased which will smooth the plot line. You can also change bar plots, fill base line, interpolation and point style. X-Scale adjusts the x-scale. Y-Scale adjusts the y-scale and enables the secondary y-axis.

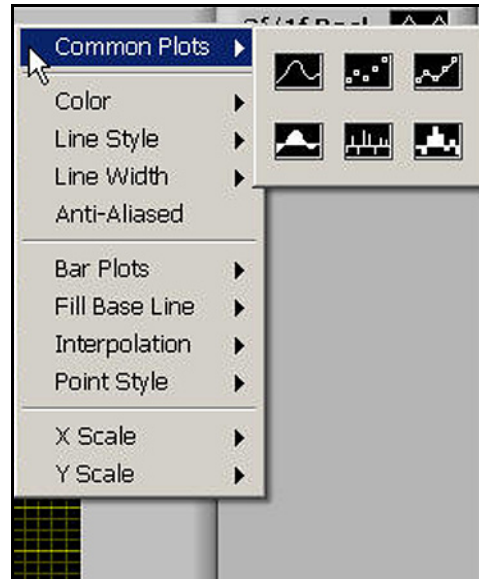

Figure 74: Options for Graphing Data

3. There is a series of Graph Tools available at the top left of the trend plot area (see *Figure 75* below).

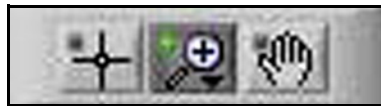

Figure 75: Graph Tools

- Pointer
- Zoom Tool - gives you six options as shown in *Figure 76* below.
- Hand Tool - Enables you to graph the trend plot area and move it around without rescaling.

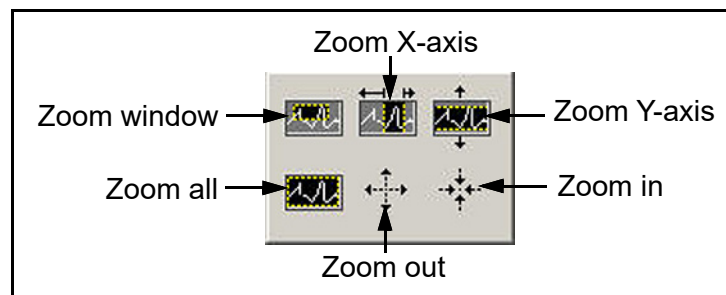

Figure 76: Zoom Tool

4. Copying and Pasting a Trend Plot can be done from AuroraView (see Figure 77 and Figure 78 below) One way to do this quickly is to simply right click over the data area and choose Copy. In another application, like Microsoft Word, simply paste.

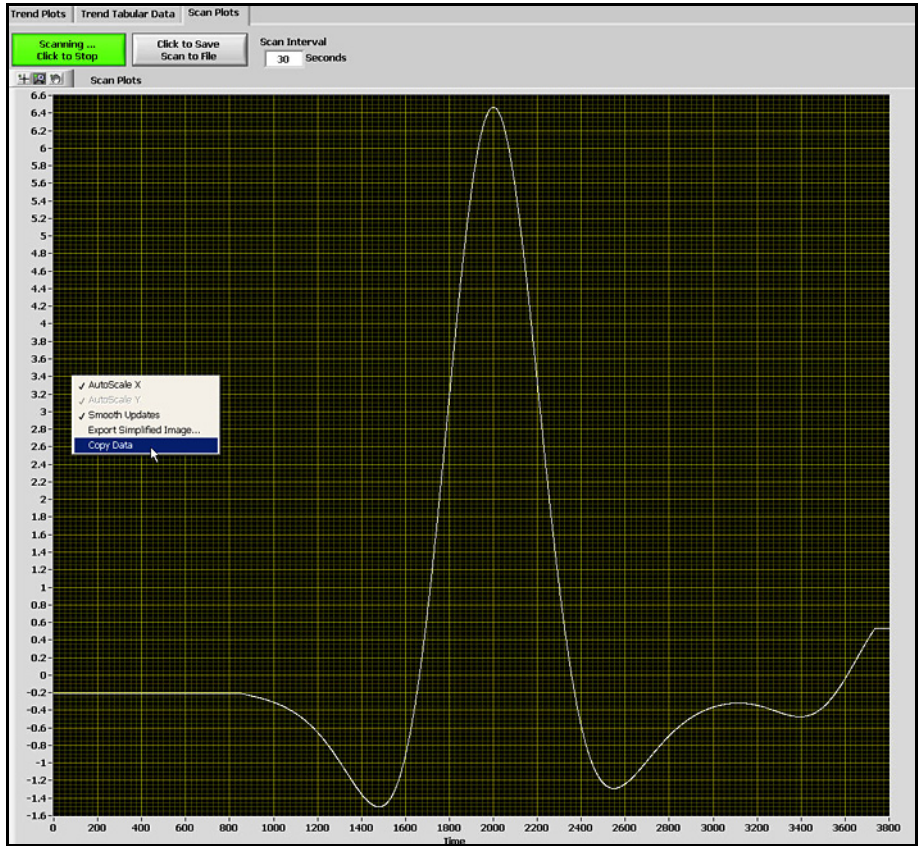

Figure 77: Copying a Trend Plot

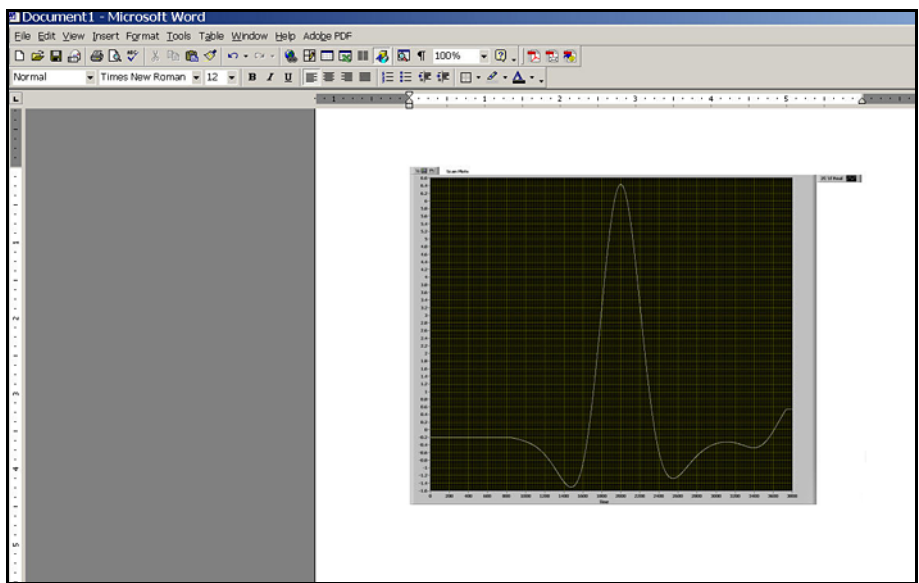

Figure 78: Pasting a Trend Plot

Another option is to right-click and choose the option Export Simplified Image (see *Figure 79* below). When you do this, a variety of image file formats will appear. A good universal option is Enhanced Metafile (see *Figure 80* on page 98). Pasting an enhanced metafile will give you the ability to paste an image with an inverted color scheme as shown in the second example posted into Word (see *Figure 81* on page 98).

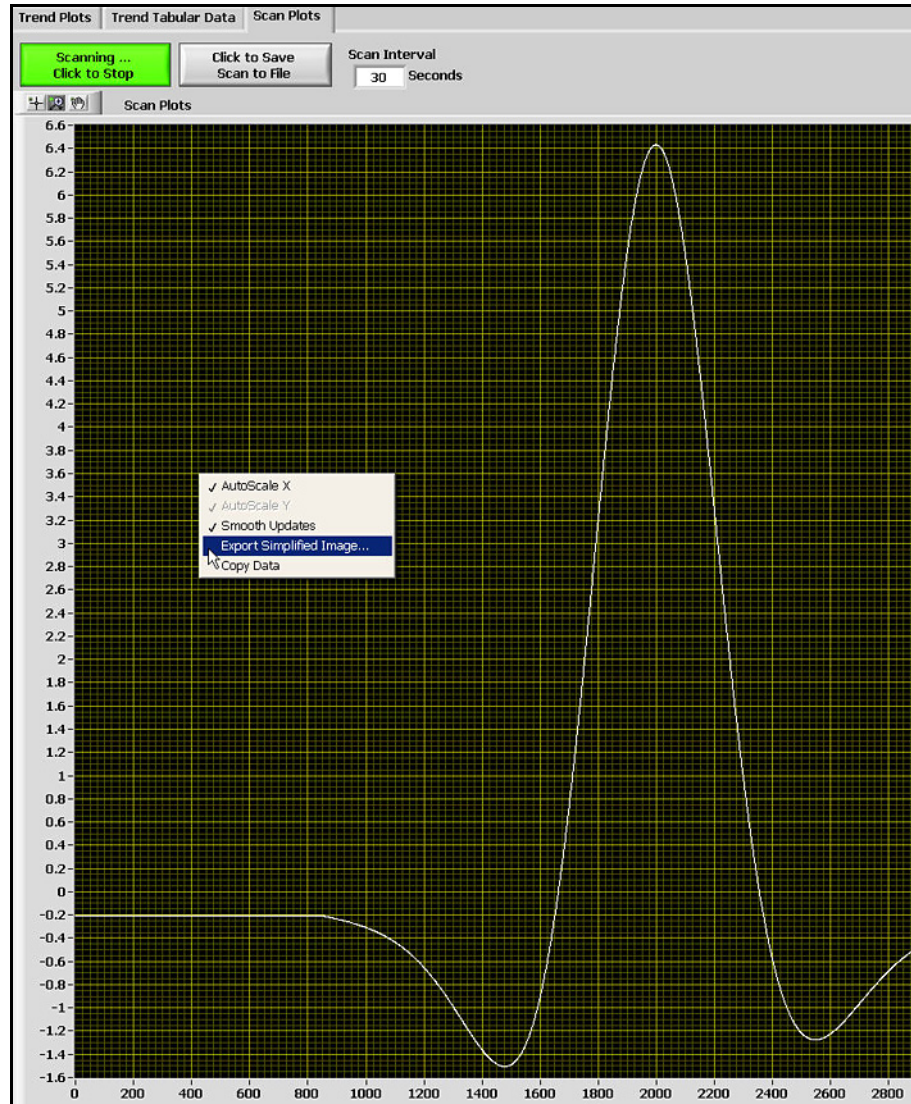

Figure 79: Exporting a Simplified Image

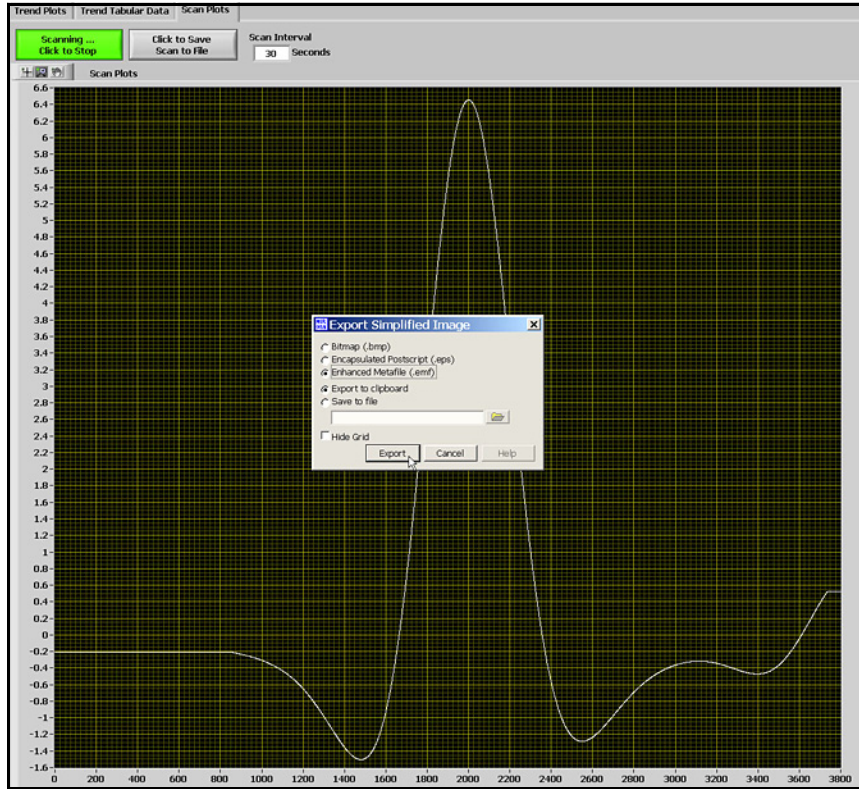

Figure 80: Selecting Enhanced Metafile

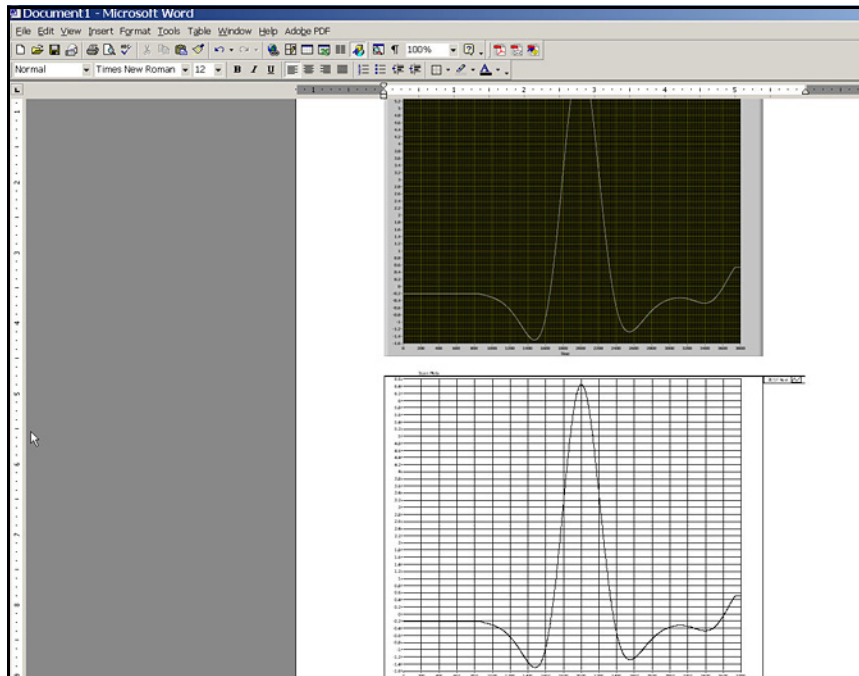
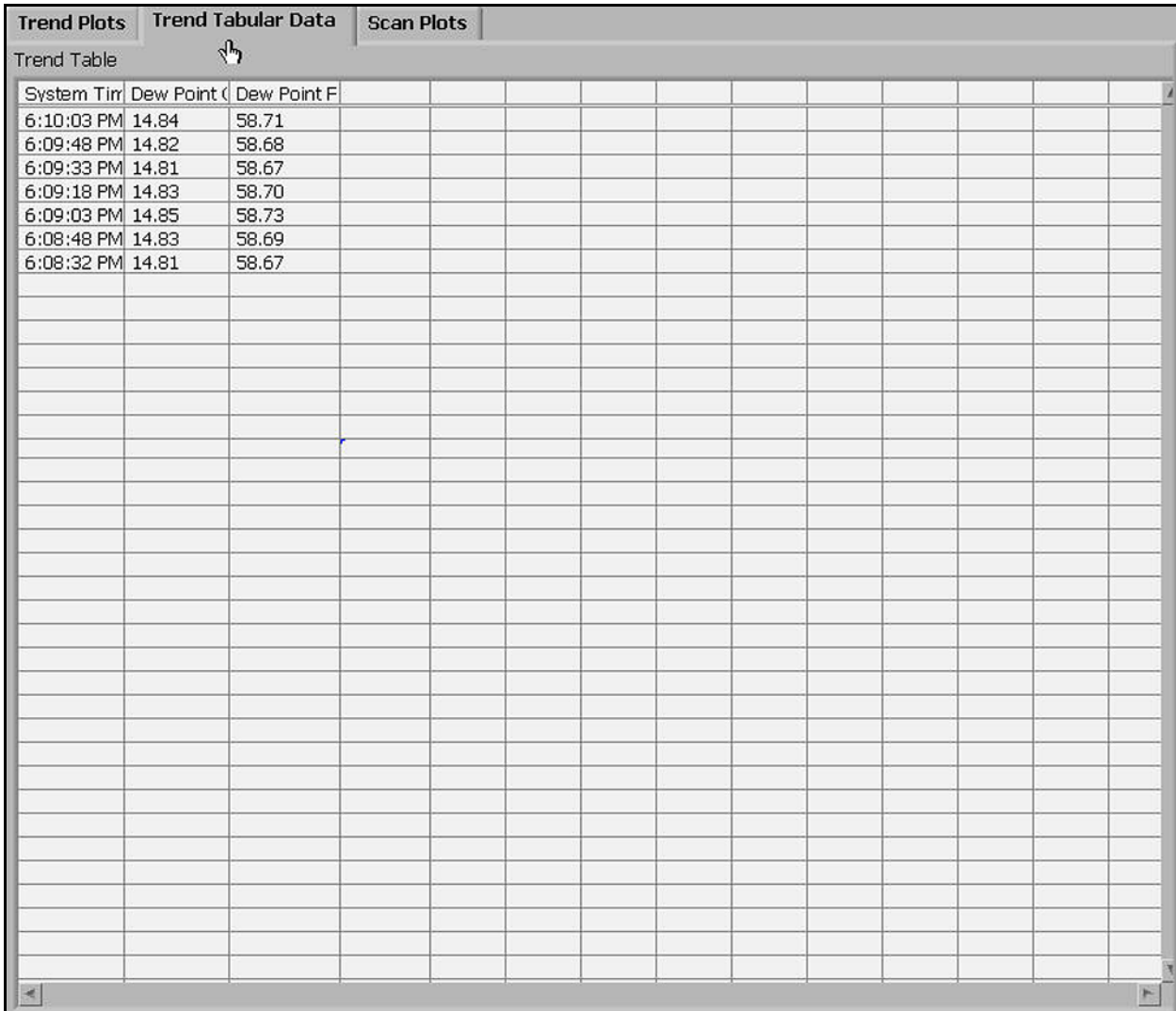

Figure 81: Pasting an Enhanced Metafile

Working with Trend Tabular Data, you will be able to see data in tabular format as shown in *Figure 82* below. You can adjust column widths to see data more easily with full titles in the header row.



System Time	Dew Point C	Dew Point F
6:10:03 PM	14.84	58.71
6:09:48 PM	14.82	58.68
6:09:33 PM	14.81	58.67
6:09:18 PM	14.83	58.70
6:09:03 PM	14.85	58.73
6:08:48 PM	14.83	58.69
6:08:32 PM	14.81	58.67

Figure 82: Trend Data in Tabular Format

[no content intended for this page]

Chapter 6. Maintenance



CAUTION! CLASS 1M INVISIBLE LASER RADIATION WHEN OPEN. DO NOT VIEW DIRECTLY WITH OPTICAL INSTRUMENTS.



WARNING! Use of controls or adjustments or performance of procedures other than those specified herein may result in radiation exposure that is more hazardous than specified.

6.1 Spare Parts

Table 5: Aurora H2O Spare Parts List

Part No.	Description	Qty.
704-668-12	RS-232 Cable; SUB-9-F to Tinned Leads; 12 ft.	1
Aurora H2O Maintenance Kit		
N/A	Plastic Case with Foam Inserts	1
421-3230	Magnetic Stylus	1
240-199	Air Blower	1
403-161	Lens Tissue Package	1
463-030	Replacement Membrane Filter Elements	5
240-201	Allen Wrench, 5/32"	1
240-200	Allen Wrench, 3/32"	1
S40046393	Small Screw Driver	1
403-163	Gloves	4

6.2 Cleaning the Mirror

The **Aurora H2O** analyzer may provide the message Weak Signal Return - Check Mirror on the top line of the display, along with the red light "!" to the left of the main display. If this occurs, the mirror and/or the optical window of the measuring cell may be contaminated due to liquid or particulate coating/deposition.

Note: Reagent grade Acetone (Cas no. 67-64-1) may be needed for the cleaning process. The reagent is not supplied as part of the Aurora maintenance kit, and you must obtain the reagent from a local chemical supplier.

If the error condition Check Mirror is indicated, the first step is to clean the mirror. The process is as follows:

1. Turn the power to the **Aurora H2O** OFF.



CAUTION! CLASS 1M INVISIBLE LASER RADIATION WHEN OPEN. DO NOT VIEW DIRECTLY WITH OPTICAL INSTRUMENTS.



WARNING! Use of controls or adjustments or performance of procedures other than those specified herein may result in radiation exposure that is more hazardous than specified.

2. Shut down the gas flow through the optical absorption cell.
 - a. Turn the inlet isolation needle valve (item 4 in *Figure 2 on page 4* or *Figure 3 on page 5*) to the closed position.
 - b. Ensure that the sample flow rotatmeter indicates zero flow.
3. Wear a pair of disposable static dissipative Latex or Nitrile (powder free) gloves.

Note: *There are two versions of the Aurora optical absorption cell assembly (see Figure 83 below), each with its own mirror mounting mechanism. The mirror can be removed from the end of this cell for cleaning **WITHOUT DISMOUNTING** the cell. Be sure to follow the correct mirror cleaning procedure for your version of the optical absorption cell assembly.*

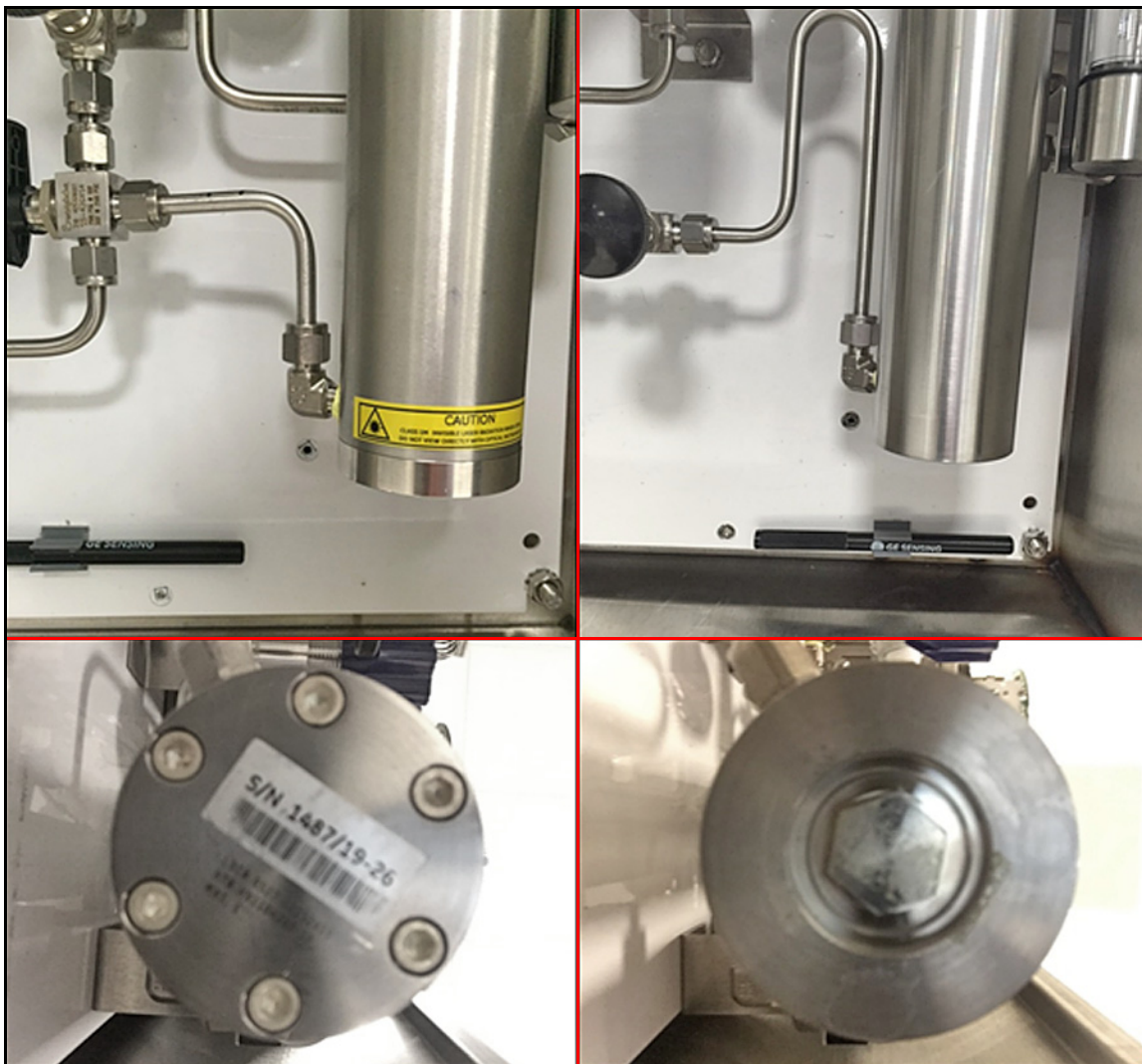

Figure 83: Style 1 (Left) and Style 2 (Right) Optical Absorption Cell/Mirror Assemblies

6.2.1 Instructions for Optical Absorption Cell Style 1

IMPORTANT: Use the instructions in this section only if you have identified your Optical Absorption Cell as Style 1 in Figure 83 on page 102.

1. Remove the 6 hex bolts securing the mirror (see *Figure 84* below) using a 5/32 inch Allen wrench. Hold the stainless steel base of the mirror with one hand while removing the last retaining bolts. The mirror is removed by pulling it straight down. There is one alignment pin (see *Figure 85* below) to facilitate proper removal.

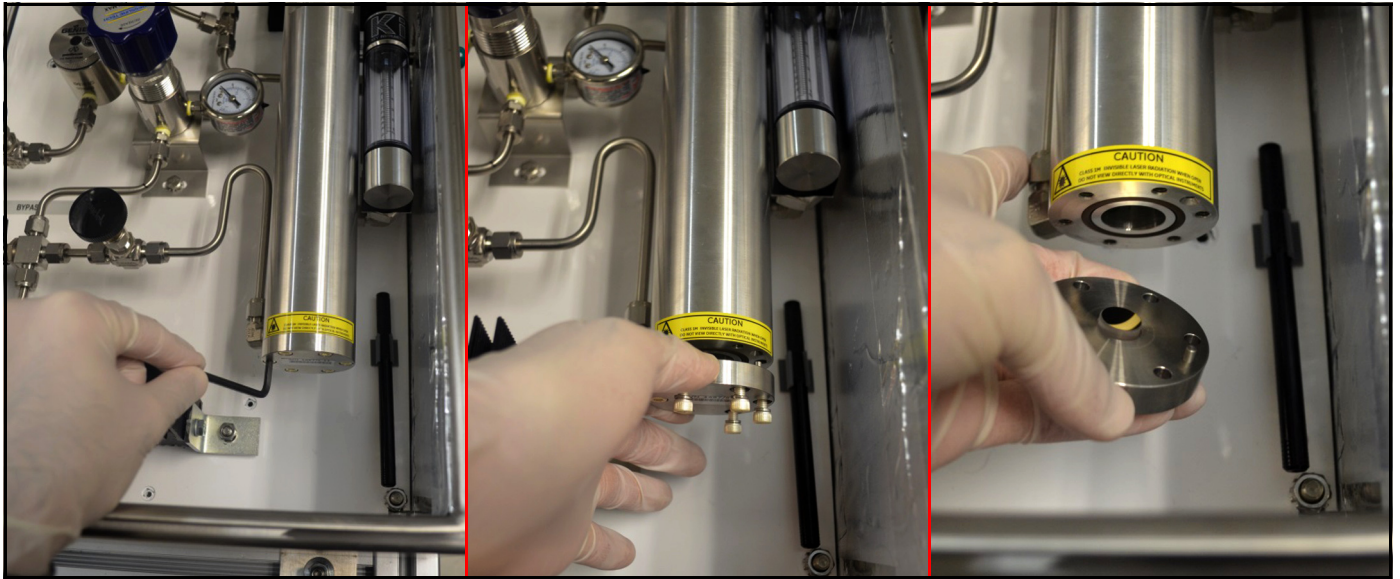

Figure 84: Removing Mirror End Cap Assembly from the Absorption Cell



CAUTION! Handle the mirror assembly with extreme care. Performance of the analyzer is critically dependent upon the mirror integrity. Do not touch the mirror surface with any tools, objects, hands or fingers.

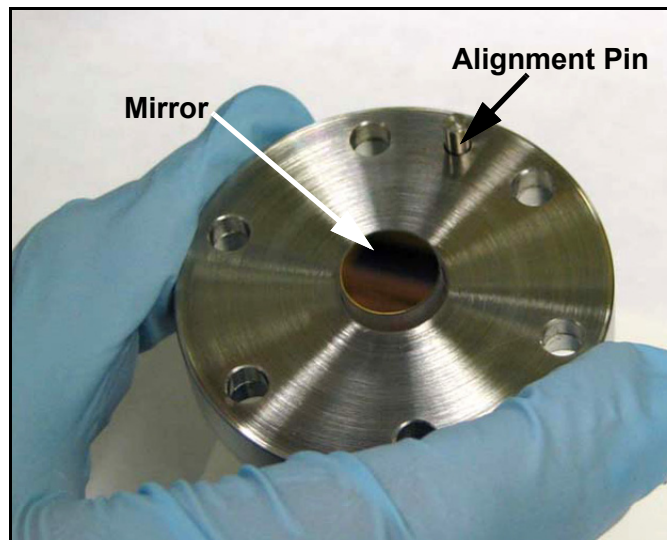

Figure 85: Handling the Mirror Assembly

6.2.1 Instructions for Optical Absorption Cell Style 1 (cont.)

2. Make a visual inspection of the mirror surface (see *Figure 86* below). Record any observation of gross contamination. If the mirror appears to be clean, do not clean it. Instead, reinstall it carefully into the system.



Figure 86: Examining the Mirror

3. If the mirror is contaminated, the first step in cleaning it is to use the air blower to blow away any particulate matter on the mirror surface. Place the mirror assembly on a flat surface and repeatedly puff the air blower to force dry clean air onto the mirror surface (see *Figure 87* below).



Figure 87: Blowing Air onto the Mirror

6.2.1 Instructions for Optical Absorption Cell Style 1 (cont.)

- Using a piece of lens tissue, wet a small area with a very small amount of **analytical grade acetone** (barely wet the lens tissue). Typically, one drop of acetone will suffice. Tilt the lens tissue so that the acetone drop is absorbed by the lens paper along the length of the piece (see *Figure 88* below).

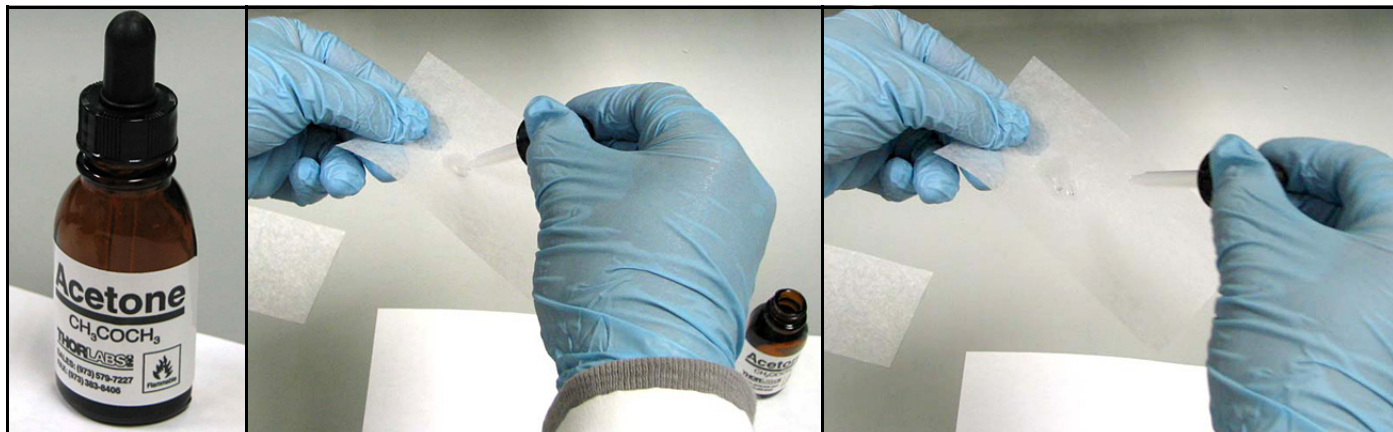

Figure 88: Using Analytical Grade Acetone

- Place the wet lens tissue on top of the mirror and drag it horizontally across the surface of the mirror (see *Figure 89* below), ensuring minimal liquid residue/streaks are left behind on the mirror surface.

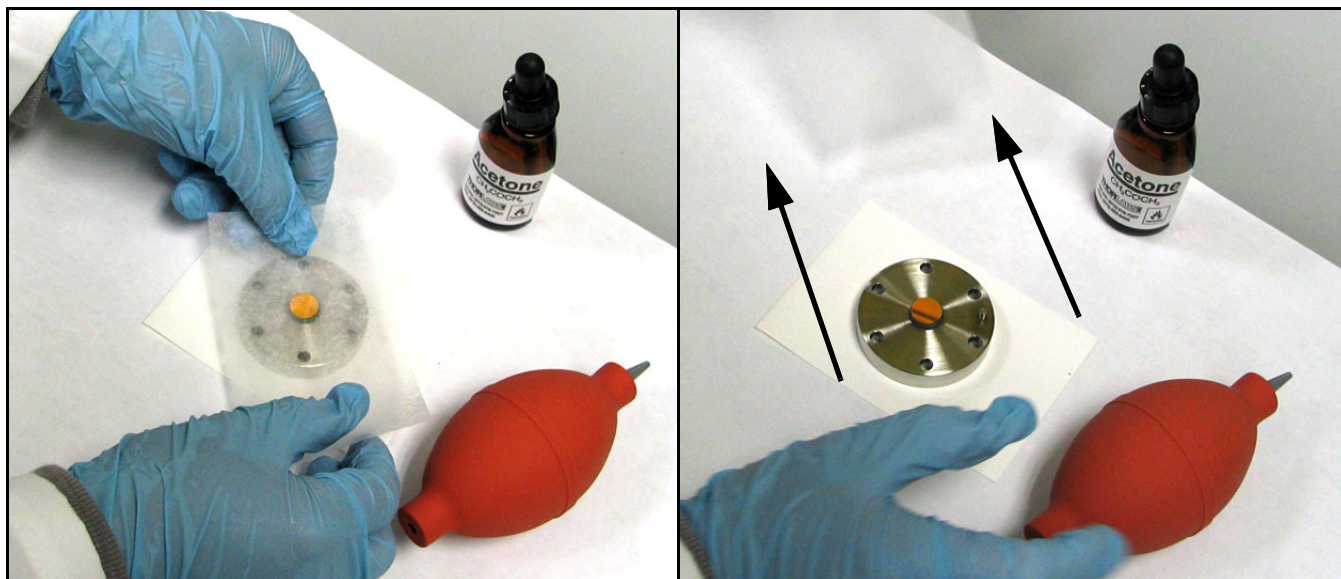

Figure 89: Dragging the Wet Lens Tissue Across the Mirror

6.2.1 Instructions for Optical Absorption Cell Style 1 (cont.)

6. Use the air blower to blow dry air onto the surface of the mirror. Puff repeatedly until the mirror surface appears dry (see Figure 90 below).

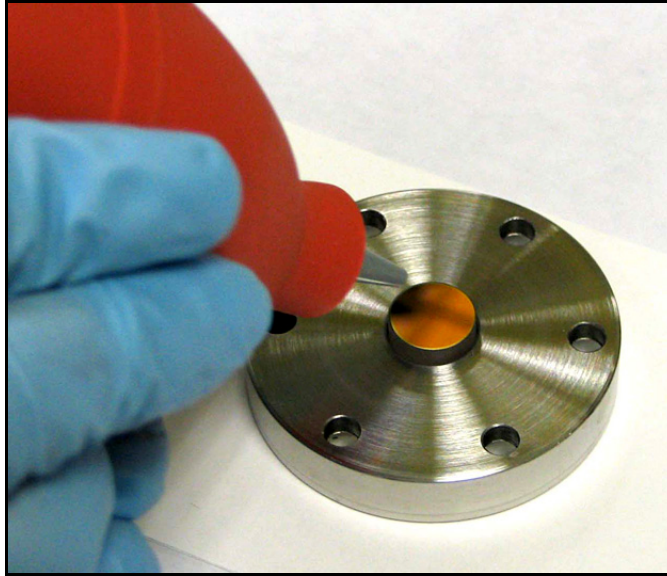

Figure 90: Drying the Mirror

7. Repeat steps 4-6 at least three times, using a new lens tissue each time. Each lens tissue wetted with acetone is used only once to clean off any visible residue on the mirror surface.
8. Visually inspect the mirror, and record any observation of gross contamination.
9. If the mirror does not appear to be clean after repeated cleanings, contact Panametrics Technical Support for further assistance.
10. If the mirror does appear to be clean, re-install it onto the measurement cell.

6.2.1 Instructions for Optical Absorption Cell Style 1 (cont.)

11. As you line up the mirror with the measurement cell, note the “key” for properly connecting the two pieces. The mirror will align for mounting in only one position. Rotate the mirror assembly to line up the alignment pin with the alignment pin slot (see *Figure 91* below).

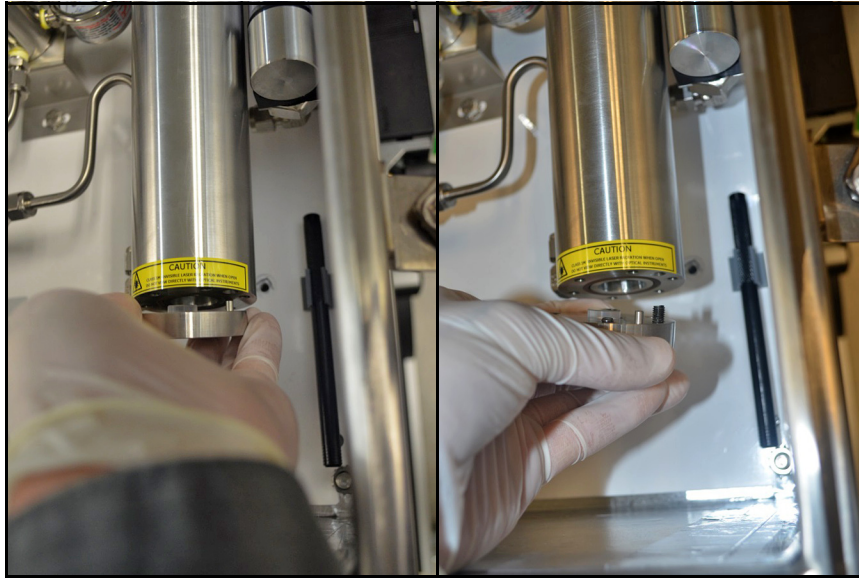

Figure 91: Reinstalling the Mirror End Cap Assembly

12. Loosely reinstall the six retaining bolts by hand.
13. Use an Allen wrench to tighten the six retaining bolts in an alternating or star pattern to achieve a uniform metal-to-metal contact. Tighten the bolts just until they are snug - **DO NOT** over-tighten these bolts.
14. Re-establish power to the **Aurora H2O** analyzer.
15. Re-establish the flow through the sample system.
16. If the **Aurora H2O** still indicates a Check Mirror fault after normal start-up, contact Panametrics Technical Support for further assistance.

6.2.2 Instructions for Optical Absorption Cell Style 2

IMPORTANT: Use the instructions in this section only if you have identified your Optical Absorption Cell as Style 2 in Figure 83 on page 102.

1. Using a 5/8" socket wrench to loosen the hex head of the mirror assembly, gently unscrew the mirror assembly from the bottom of the absorption cell. While *Figure 92* below shows this procedure for a dismantled cell, it is **NOT** necessary to dismount the optical absorption cell assembly to remove the mirror.
2. In cases of excessive contamination/grease entering the optical cell, this mirror could get stuck to the bottom of the cell when the end cap is removed. The mirror should be gently removed by pulling it straight down.

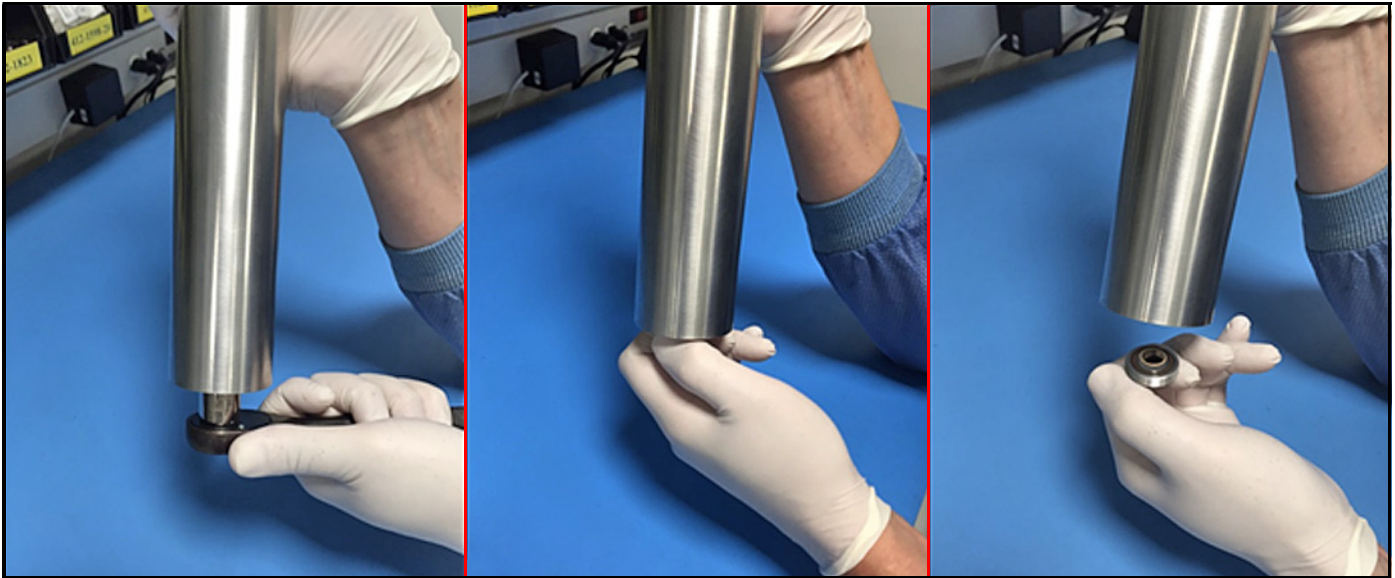

Figure 92: Removing Mirror End Cap Assembly from the Absorption Cell



CAUTION! Handle the mirror assembly with extreme care. Performance of the analyzer is critically dependent upon the mirror integrity. Do not touch the mirror surface with any tools, objects, hands or fingers.

6.2.2 Instructions for Optical Absorption Cell Style 2 (cont.)

3. Gently place the extracted mirror assembly on a clean lens tissue. Using a pair of plastic-tipped tweezers gently extract the 0.5" diameter mirror from the end cap, taking care not to touch, squeeze or nick the two O-rings in the end cap assembly (see *Figure 93* below).

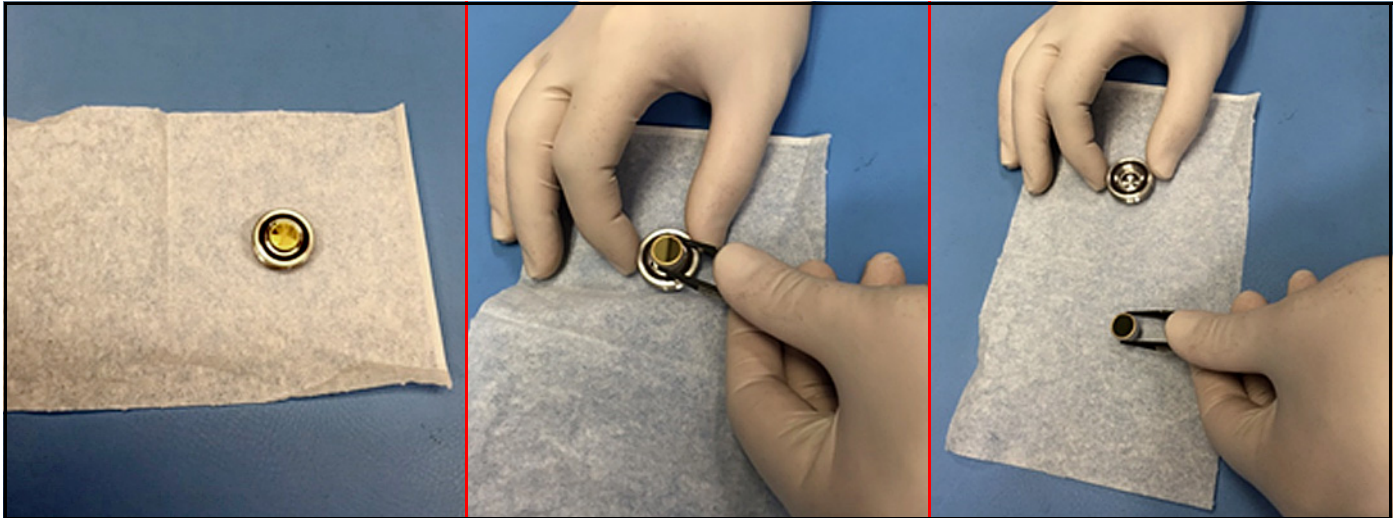

Figure 93: Inspecting the Mirror Assembly

4. Make a visual inspection of the mirror surface, and record any observations of gross contamination. If the mirror appears to be clean, do not clean it. Instead, reinstall it carefully into the system (go to Step 12).
5. If the mirror is contaminated, the first step in cleaning it is to use the air blower to blow away any particulate matter on the mirror surface. Place the mirror on a flat surface holding it from the sides with a pair of plastic tipped tweezers and repeatedly puff the air blower to force dry clean air onto the mirror surface (see *Figure 87* on page 104).
6. Using a piece of lens tissue, wet a small area with a very small amount of analytical grade acetone (barely wetting the lens tissue). Typically, one drop of acetone will suffice. Tilt the lens tissue so that the acetone drop is absorbed by the lens paper along the length of the piece (see *Figure 88* on page 105 and *Figure 94* below).



Figure 94: Applying Acetone to Lens Tissue

6.2.2 Instructions for Optical Absorption Cell Style 2 (cont.)

7. Place the wet lens tissue on top of the mirror and drag it horizontally across the surface of the mirror, while holding it on with a pair of plastic-tipped tweezers (see *Figure 95* below). Ensure that minimal liquid residue or streaks are left behind on the mirror surface.

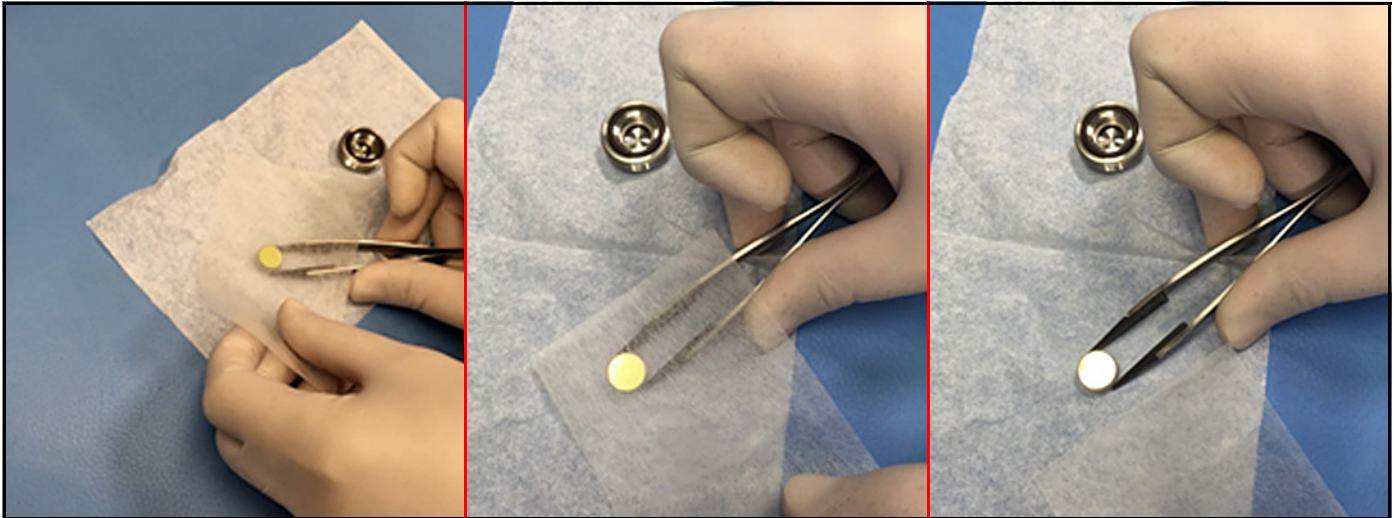

Figure 95: Cleaning a Contaminated Mirror

8. Use the air blower to blow dry air onto the surface of the mirror while holding it with the tweezers. Puff repeatedly until the mirror surface appears dry (see *Figure 90* on page 106).
9. Repeat **Steps 6-8** above at least three times, using a new lens tissue each time. Each lens tissue wetted with acetone is used only once to clean off any visible residue on the mirror surface.
10. Visually inspect the mirror, and record any observation of residual contamination.
11. If the mirror does **NOT** appear clean after repeated cleaning, contact Panametrics Technical Support for further assistance.
12. If the mirror does appear to be clean, replace it into the mirror end cap, taking care not to disturb the two O-rings in the assembly (see *Figure 96* below), Prepare to re-install the mirror end cap assembly into the optical absorption cell.



Figure 96: Replacing Cleaned Mirror into End Cap Assembly

6.2.2 Panametrics Instructions for Optical Absorption Cell Style 2 (cont.)

- Using tweezers, insert the mirror into the hole on top of the shim, with the gold-plated side facing up. Thread the end cap into the bottom of the absorption cell tube. Secure the threaded end cap in place with a 5/8" socket wrench (see Figure 97 below).

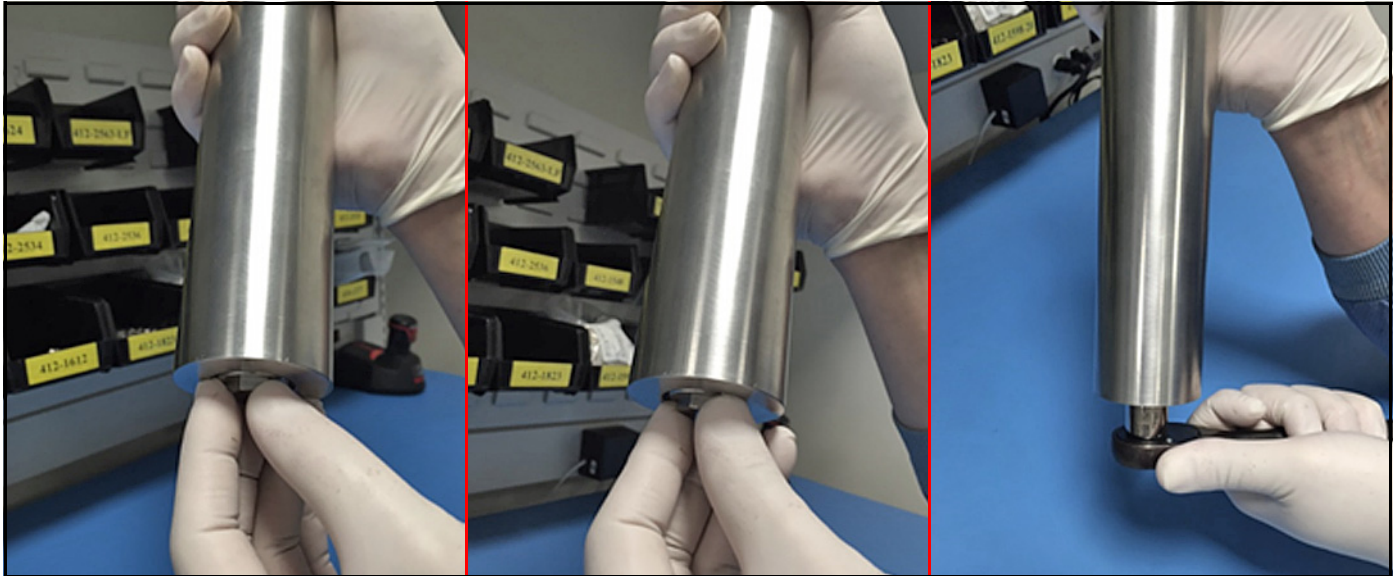

Figure 97: Replacing Mirror End Cap Assembly into the Absorption Cell

- Re-establish power to the **Aurora H2O** analyzer.
- Re-establish the flow through the sample system.
- If the **Aurora H2O** still indicates a Check Mirror fault after normal start-up, contact Panametrics Technical Support for further assistance.

6.3 Replacing the Filter Element



The **Aurora H2O** uses a membrane filter (see *Figure 98* to the left) as the secondary filter. This filter is intended to prevent liquid or particulate contamination from entering the absorption cell. The Aurora should not be operated without a filter train upstream of the unit. The membrane filter is equipped with “*Flow Block*” which shuts off the flow if the filter element is heavily loaded with contamination. A spring loaded check valve closes the outlet flow of the sample if the differential pressure across the filter element exceeds a threshold limit. At any given time the flow through the **Aurora H2O** can be checked by observing the rotameter. If the “*flow block*” feature shuts off the flow, do not increase the pressure. Replace the filter element and clean the filter.

Figure 98: Membrane Filter

If the flow is being shut off too frequently, additional sample condition schemes, or the combination of the following, will have to be employed:

- **Bypass flow** – needed to sweep liquids or contamination off the filter. A 10:1 bypass flow rate should be maintained.
- Additional upstream filtration
- **Heat** – Heat tracing of the sample line and sample system components, sufficiently above both the water and hydrocarbon dew point, will keep the sample in the gas phase.

To replace the filter element, complete the following steps:

1. Close the inlet isolation needle valve and allow the system to fully depressurize.
2. Turn the filter cap counter-clockwise (see *Figure 99* below). You might need to use a channel-lock wrench to assist in loosening the cap.

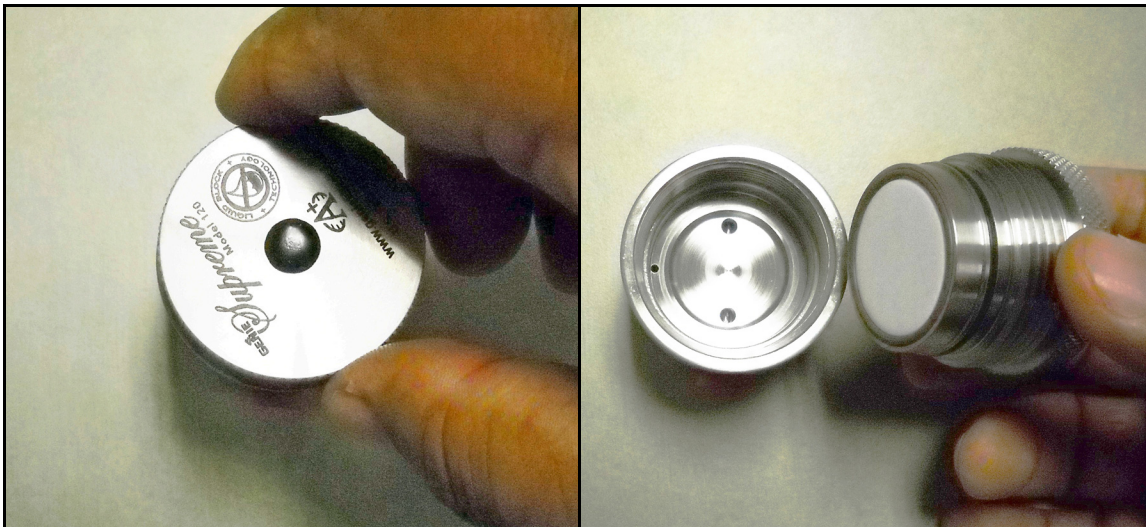

Figure 99: Removing the Filter Cap

6.3 Replacing the Filter Element (cont.)

3. Place the filter cap on a horizontal flat surface, filter side up.
4. Carefully remove the large O-ring (see *Figure 100* below).

Note: Because the O-rings are reused, replacement O-rings are not included in the maintenance kit.



Figure 100: Orient the Filter Cap and Remove the Large O-Ring

5. Remove the white membrane filter element and the membrane backing plate (see *Figure 101* below).



Figure 101: Remove the White Filter Element and the Backing Plate

6.3 Replacing the Filter Element (cont.)

6. Remove the small O-ring (see *Figure 102* below).



Figure 102: Remove the Small O-ring

7. Using a tissue, clean the filter components (see *Figure 103* below).

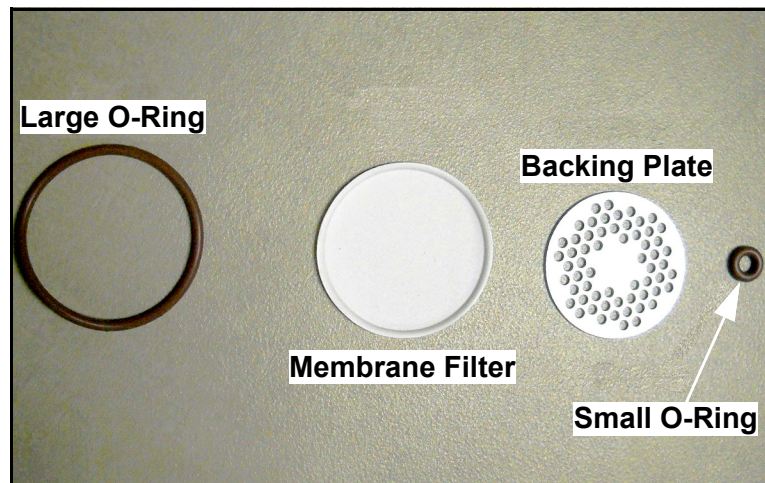

Figure 103: O-Rings, Membrane Filter and Backing Plate Removed

8. Re-assemble the filter, and reinstall the cap hand-tight.

Chapter 7. Troubleshooting

7.1 Introduction

The following are possible **Aurora H2O** analyzer conditions with details on how to deal with them.

7.2 Blank Display

1. Is the green POWER LED lit?
 - a. Yes - proceed to **Step 2**.
 - b. No - Check the wiring and the fuse
2. Are the four arrow keys illuminated?
 - a. Yes - If the keys remain illuminated for more than 12 seconds, the *Boot Loader* cannot find a valid *Instrument Program* to run.
 - b. No - contact the factory for service.

7.3 Display Dim or Hard to Read

1. Adjust the LCD brightness and contrast using the **Display/Adjust** menu.

7.4 Status Messages and Indicators

The **Aurora H2O** categorizes status messages as either *Faults*, *Warnings*, or *Information*. Status messages are displayed in the upper right corner of the display, with continuous scrolling from right to left for long messages.

- A **fault** is a non-recoverable condition that can affect the quality of measurement by the **Aurora H2O**. Fault messages are accompanied by a slow flashing (!) indicator.
- A **warning** is a recoverable condition that can affect the quality of measurement by the **Aurora H2O**. Warning messages are accompanied by a rapid flashing (!) indicator.
- **Information** messages alert the operator to a condition that is abnormal, but does not affect the quality of measurements. Information messages are accompanied by a slow flashing (i) indicator.

Aurora H2O fault and status messages are prioritized. In case of more than one fault/status condition, the condition with the highest priority is displayed. When that condition is resolved, the next highest priority condition is displayed.

7.4 Status Messages and Indicators (cont.)

The possible status messages and indicators are summarized in *Table 6* below.

Table 6: Status Messages and Indicators

Message	Condition	Description
Status OK	Info	Aurora H2O is operating normally, no faults or other indications.
No CH4 detected	Info	Aurora H2O is reading moisture, but cannot detect the presence of methane.
H2O Under Range	Info	The moisture level is below the system detection limits.
Warning - System Overheating	Fault	The temperature inside the electronics module exceeds 85°C or the air temperature inside the sample system enclosure exceeds 68°C. The laser is powered off until the electronics module temperature is below 80°C, and the sample system enclosure temperature is below 65°C.
FAULT: Temperature	Fault	The temperature transducer is operating out of limits, is disconnected, or has failed.
FAULT: Sample Pressure	Fault	The internal (sample) pressure transducer is operating out of limits, is disconnected, or has failed.
FAULT: Line Pressure	Fault	The external (line) pressure transmitter is operating out of limits, is disconnected, or has failed. Occurs if source of the line pressure measurement is set to "Live", and no pressure transmitter is attached.
Laser Temp Unstable...	Warning	The temperature of the laser is not stable. This warning occurs briefly at power on, as the Aurora H2O sets the correct operating temperature. The laser is powered off until the temperature has stabilized.
Laser Adjust at Limits	Info	Aurora H2O has reached the limit for adjusting the laser power. Contact the factory for assistance.
Laser Reference Fail	Fault	Aurora H2O could not detect any signal from the laser. Contact the factory for assistance.
Weak Signal Return - Check Mirror	Info	Aurora H2O could not detect a signal returned from the sample cell, or the signal is below allowed limits. Check mirror for contamination.
FAULT: TEC FAIL	Fault	Aurora H2O has detected a failure in the laser temperature control. Contact the factory for assistance.
WARNING - Sample Pressure TOO HIGH	Warning	The pressure in the Aurora H2O sample cell is greater than 212 kPa (30.75 psia). Verify regulator and flow settings; check for blocked vent line or excessive back pressure.
ERROR: TEC Setpoint out of Range	Fault	The Aurora H2O temperature controller is was set beyond its operating limits. Contact the factory for assistance.
Service Req: ###	Fault	Aurora H2O has detected a fault condition that has no associated status message. Contact the factory for assistance.

7.5 No Flow Measurement Indicated on Aurora H2O Measurement Cell Outlet

Check to make sure that the outlet of the **Aurora H2O** is venting to atmospheric pressure. Ensure that the sample system valves are configured correctly and that the **Aurora H2O** internal pressure regulator is capable of a barely positive pressure setting. Check/Replace the filter element in the coalescer/filter as described in Chapter 5, *Maintenance*.

7.6 Verifying Aurora H2O Performance in the Field

There are two methods for verifying the performance of the **Aurora H2O** in the field. The first method is to use a portable hygrometer such as *Panametrics's PM880* portable hygrometer. The second method is to use a moisture generator or standard gas cylinder.

7.6.1 Using A Portable Hygrometer

One quick spot check that can be done, that is relatively easy to do and requires minimal set-up time and no consumables, is to use a second hygrometer. *Panametrics* recommends using a *PM880 Portable Hygrometer* (see *Figure 104* below) for this purpose, with a recently calibrated *Aluminum Oxide Moisture Probe*.



Figure 104: PM880 Portable Hygrometer

The *PM880* can be connected to the outlet of the **Aurora H2O** analyzer, using the portable sample system with the aluminum oxide moisture probe, to verify the system. The response time of the portable hygrometer is limited, as the sensor is typically exposed to air during movement to the sample point. So, it is recommended that the sample gas remains flowing through the portable sample system on the sample outlet of the **Aurora H2O** until equilibrium with the moisture concentration of the sample gas is reached. You can use the data-logging capability of the *PM880* to determine when steady-state conditions are reached. Consult *Panametrics* if you have application questions regarding this process.

7.6.2 Using a Moisture Standard

The best moisture standard to use is one generated by a moisture generator as a flowing reference, due to the fact that static moisture standards in cylinders have limited capability and reliability. A moisture generator such as Panametrics's *MG101* moisture generator (see *Figure 105* below) can be used for this purpose.



Figure 105: MG101 Moisture Generator

However, a moisture generator is typically used only in an indoor location with reasonably good temperature control. In the field this is not always practical, so a more convenient option would be to use a static moisture standard in a gas cylinder. Consult with your local specialty gas supplier about standards for moisture. Based on application experience, Panametrics recommends the following guidelines regarding moisture standards in gas cylinders:

- Use passivated, aluminum gas cylinders only.
- Do not use the cylinder when the pressure falls below 50% of the original pressure supplied by the vendor (typically 1500–1800psig).
- Use the gas cylinder for moisture values of 50–100 ppm.
- Use a moisture standard having a background gas of nitrogen (N₂).
- Mix the moisture standard for 10 minutes prior to use, following the manufacturer's guidelines (rolling the cylinder is typical).
- Use the gas cylinder at the nominal temperature at which the cylinder was tested by the manufacturer.

Whether using a moisture generator or a standard moisture gas cylinder, the source gas should be connected to the **Aurora H2O** using the **PURGE INLET** on the analyzer. Ensure that the sample gas pressure is regulated to a just barely positive pressure and establish gas flow from the **PURGE INLET** to the **Aurora H2O** measurement cell.

7.7 Background Selection Lockout

To prevent accidental selection or tampering, the Background menu option can be disabled using a mechanical switch located behind the **Aurora H2O** display. Access to the switch requires removal of the cover, and should be performed only in non-hazardous conditions.

Note: Unless otherwise requested, the **Aurora H2O** is shipped with the Background selection unlocked.

The **Lockout** switch is positioned to the right of the **Laser Indicator** (see *Figure 106* below). When the switch is in the **UP** position, the **Background Selection** menu is unlocked. When the switch is in the **DOWN** position, the **Background Selection** menu is locked.



Figure 106: Background Selection Lockout Switch Location

Attempting to access the **Background Gas Selection** menu with the switch in the **Locked Out** (down) position will result in the following message being displayed:

```
Menu:X
Gas select is locked.
Use Gas Lockout
switch to unlock.
```

[no content intended for this page]

Appendix A. MODBUS RTU/TCP Communications

A.1 Introduction

The **Aurora H2O** supports digital communications using the Modbus/RTU protocol, with 2-wire RS-485 or 3-wire RS-232C as the physical layer. Data rate can be specified at rates from 4800 to 115200 bits per second (bps), with selectable parity.

The **Aurora H2O** supports the Modbus/TCP protocol as defined in: MODBUS Messaging on TCP/IP Implementation Guide V1.0b.

Aurora H2O has two physically separate communications ports. Both ports can be selected for either RS-232 or RS-485 operation, and **Aurora H2O** can communicate with both ports simultaneously.

Note: **Aurora H2O** supports the Modbus/RTU protocol as defined in:

MODBUS Application Protocol Specification, V1.1b
&
MODBUS over Serial Line Specification and Implementation Guide V1.02.

Note: The above referenced specifications are available from the Modbus Organization at <http://modbus-ida.org>.

A.2 Modbus Functions and Data Types

The Modbus functions supported by **Aurora H2O** include:

- (0x03) Read Holding Registers
- (0x04) Read Input Registers
- (0x08) Diagnostics (Serial Line only) - only supports Echo subcommand
- (0x10) Write Multiple registers
- (0x11) Report Slave ID (Serial Line only)
- (0x2B/0x0E) Read Device Identification - only supports Basic Device Identification tags, which are:
 - VendorName
 - Product code
 - Revision number

Aurora H2O supports data types of Integer and Double/Float. Integer data types are always four (4) bytes long and should be read with a request for two registers (two bytes per each register, two registers total) at the address. Double/Float data types provide eight (8) byte double precision data or four (4) byte single precision data, depending on how many registers are requested. Four registers are used for double data types, and two registers are used for single precision data types.

Aurora H2O Modbus register addresses are *zero-based*. Certain Modbus master software and devices use *one-based* addressing. With such devices, simply add 1 to the register addresses in *Table 7 on page 122* for correct operation.

A.3 Modbus Registers

All registers denoted with a bullet (•) in the Read-Only column are read-only registers and should be read with the function “Read Input Registers.” All other registers can be read and written with “Read Holding Registers” or “Write Multiple Registers.”

Note: The Modbus Register Address map supported by **Aurora H2O** is shown in Table 7 below.

Table 7: Modbus Register Map

Function	Parameter	Description	Range/State	Addr	Data Type	Read Only
System Status ¹	Status Register			0	Integer	
	Status Register, Latched	Write 0 to clear		1000	Integer	
Display	Data/Plot	Select Plot or Data Display view	0 = Data View 1-60 = Plot view duration, in minutes	1010	Integer	
	Primary Units	Measurement unit to display	Reg. address of Meas.	1100	Integer	
	Primary Decimals	# of decimal places to display	Measurement dependent	1110	Integer	
	Alt 1 (Left) Units	Measurement unit to display	Reg. address of Meas.	1200	Integer	
	Alt 1 (Left) Decimals	# of decimal places to display	Measurement dependent	1210	Integer	
	Alt 2 (Right) Units	Measurement unit to display	Reg. address of Meas.	1300	Integer	
	Alt 2 (Right) Decimals	# of decimal places to display	Measurement dependent	1310	Integer	

Table 7: Modbus Register Map

Function	Parameter	Description	Range/State	Addr	Data Type	Read Only	
Analog Output	Output 1	Trim Sequence Start/Resume Live Output ²		2100	Integer		
		Units	Reg. address of Meas.	2110	Integer		
		Type	0 = 4-20mA, 1 = 0-20mA	2120	Integer		
		Trim Reading Zero	3.0 ~ 5.2	2140	Double/Float		
		Trim Reading Span	10.0 ~ 22.2	2150	Double/Float		
		Upper of Value	-10000 ~ 10000	2160	Double/Float		
		Lower of Value	-10000 ~ 10000	2170	Double/Float		
		Test	% value of output, 0-100	2180	Double/Float		
	Output 2	Trim Sequence Start/Resume Live Output ²			2200	Integer	
		Units	Reg. address of Meas.		2210	Integer	
		Type	0 = 4-20mA, 1 = 0-20mA		2220	Integer	
		Trim Reading Zero	3.0 ~ 5.2		2240	Double/Float	
		Trim Reading Span	10.0 ~ 22.2		2250	Double/Float	
		Upper of Value	-10000 ~ 10000		2260	Double/Float	
		Lower of Value	-10000 ~ 10000		2270	Double/Float	
		Test	% value of output, 0-100		2280	Double/Float	
	Output 3	Trim Sequence Start/Resume Live Output ²			2300	Integer	
		Units	Reg. address of Meas.		2310	Integer	
		Type	0 = 4-20mA, 1 = 0-20mA		2320	Integer	
		Trim Reading Zero	3.0 ~ 5.2		2340	Double/Float	
		Trim Reading Span	10.0 ~ 22.2		2350	Double/Float	
		Upper of Value	-10000 ~ 10000		2360	Double/Float	
		Lower of Value	-10000 ~ 10000		2370	Double/Float	
		Test	% value of output, 0-100		2380	Double/Float	

Table 7: Modbus Register Map

Function	Parameter	Description	Range/State	Addr	Data Type	Read Only	
Alarm	All Alarm Status		0 ~ 7 (Bitfield)	3000	Integer		
	Alarm 1	Status		0 = Not tripped, 1 = Tripped	3100	Integer	
		Switch		0 = OFF, 1 = ON	3110	Integer	
		Units		Reg. address of Meas.	3120	Integer	
		Type		Set Point = 0, In Band = 1, Out Band = 2	3130	Integer	
		Upper		Depends on unit type	3140	Double/Float	
		Lower		Depends on unit type	3150	Double/Float	
	Alarm 2	Status		0 = Not tripped, 1 = Tripped	3200	Integer	
		Switch		0 = OFF, 1 = ON	3210	Integer	
		Units		Reg. address of Meas.	3220	Integer	
		Type		Set Point = 0, In Band = 1, Out Band = 2	3230	Integer	
		Upper		Depends on unit type	3240	Double/Float	
		Lower		Depends on unit type	3250	Double/Float	
	Alarm 3	Status		0 = Not tripped, 1 = Tripped	3300	Integer	
		Switch		0 = OFF, 1 = ON	3310	Integer	
		Units		Reg. address of Meas.	3320	Integer	
		Type		Set Point = 0, In Band = 1, Out Band = 2	3330	Integer	
		Upper		Depends on unit type	3340	Double/Float	
Lower			Depends on unit type	3350	Double/Float		
Settings	Adjust	PPM Level offset adjust	-25.00 ~ +25.00	5210	Double/Float		
		Moisture reading average filter size	10 ~ 200 samples	5230	Integer		
	Clock	Hour		0~23	5410	Integer	
		Minutes		0~59	5420	Integer	
		Month		1~12	5430	Integer	
		Date		1~28/29/30/31	5440	Integer	
		Year		2000~2099	5450	Integer	
	External Pressure	Constant		0 ~ 3500.00 kPa	5510	Double/Float	
		Pressure Zero Calibration, mA		0~22 mA	5520	Double/Float	
		Pressure Span Calibration, mA		0~22 mA	5525	Double/Float	
		Pressure Zero Calibration, kPa		0~3500 kPa	5530	Double/Float	
		Pressure Span Calibration, kPa		0~3500 kPa	5535	Double/Float	
Pressure Source			Constant Value = 0, Live Sensor = 1	5540	Integer		

Table 7: Modbus Register Map

Function	Parameter	Description	Range/State	Addr	Data Type	Read Only
Device ID	Aurora H2O Serial Number	-----	-----	8100	8 Character Bytes	•
	Laser Serial Number	-----	-----	8200	8 Character Bytes	•
	Calibration Date	Month	1~12	8310	Integer	•
		Date	Depends on month	8320	Integer	•
		Year	2000~2100	8330	Integer	•
System Up Time	MSDate	Uptime, in days	8400	Double/Float	•	

Table 7: Modbus Register Map

Function	Parameter	Description	Range/State	Addr	Data Type	Read Only
Measurements	Dew Point	Dew Point °C	-----	9110	Double/Float	•
		Dew Point °F	-----	9120	Double/Float	•
		Equivalent Dew Point °C	-----	9130	Double/Float	•
		Equivalent Dew Point °F	-----	9140	Double/Float	•
	Temperature	Sample Temperature °C	-----	9210	Double/Float	•
		Sample Temperature °F	-----	9220	Double/Float	•
	External Pressure	kPa	-----	9510	Double/Float	•
		MPa	-----	9512	Double/Float	•
		PSIa	-----	9520	Double/Float	•
		PSIg	-----	9530	Double/Float	•
		kg/cm ²	-----	9540	Double/Float	•
		Bars	-----	9550	Double/Float	•
		mmHg	-----	9560	Double/Float	•
	Internal Pressure	kPa	-----	9610	Double/Float	•
		MPa	-----	9612	Double/Float	•
		PSIa	-----	9620	Double/Float	•
		PSIg	-----	9630	Double/Float	•
		kg/cm ²	-----	9640	Double/Float	•
		Bars	-----	9650	Double/Float	•
		mmHg	-----	9660	Double/Float	•
	H ₂ O Concentration	PPM	-----	9710	Double/Float	•
		Lbs MMSCF	-----	9720	Double/Float	•
		mg/sm ³	-----	9730	Double/Float	•
g/sm ³		-----	9750	Double/Float	•	
Vapor Pressure	kPa	-----	9800	Double/Float	•	

A.3 Modbus Registers (cont.)

¹Address 0 is the *System Status* register, and address 1000 is the latching version of the *System Status* register. That is, both registers will show the error bit if the error is currently present, but only the latching register will show it if the condition is no longer present. Writing 0 to the latching register will clear the error code it contains.

²The “*Trim Sequence Start/Resume Live Output*” registers for the three outputs, (address 2100, 2200, 2300) accept certain values through the *Write Multiple Register* to trim the output current:

1. Write 0 to 2x00 to select the normal mA output (proportional to measurement).
2. Write 1 to 2x00 to reset the mA output trim to factory defaults.
3. Write 2 to 2x00 to output the “zero” current (~4.000 mA) and accept a calibration value written to 2x40.
4. Write 3 to 2x00 to output the “span” current (~20.000 mA) and accept a calibration value written to 2x50.

Note: Attempting to write to Trim registers 2x40/2x50 without first writing to Trim State register 2x00 will fail with Modbus exception 4.

At the end of calibration, write 0 to 2x00 to make **Aurora H2O** exit trim mode.

A.4 Modbus System Status Codes

Table 8 below lists the System Status codes and descriptions. It is possible for multiple status codes to be present. The hexadecimal values represent the bit set for a given condition.

Table 8: System Status Codes

Status	Description
0x00000000	Aurora H2O is operating normally, no faults or other indications.
0x00000008	Aurora H2O is reading moisture, but cannot detect the presence of methane.
0x00000010	The moisture level is below the system detection limits.
0x00000020	The temperature inside the electronics module exceeds 85°C. The laser is powered off until the temperature drops below 80°C.
0x00000040	The temperature transducer is operating out of limits, is disconnected, or has failed.
0x00000080	The internal (sample) pressure transducer is operating out of limits, is disconnected, or has failed.
0x00000100	The external (line) pressure transmitter is operating out of limits, is disconnected, or has failed. Occurs if source of the line pressure measurement is set to "Live", and no pressure transmitter is attached.
0x00000200	Power supply under voltage
0x00000400	System ground fault
0x00000800	The temperature of the laser is not stable. This warning occurs briefly at power on, as the Aurora H2O sets the correct operating temperature. The laser is powered off until the temperature has stabilized.
0x00001000	Aurora H2O has reached the limit for adjusting the signal gain. Contact the factory for assistance.
0x00002000	Aurora H2O has reached the limit for adjusting the laser power. Contact the factory for assistance.
0x00004000	Aurora H2O could not detect any signal from the laser. Contact the factory for assistance.
0x00010000	Aurora H2O could not detect a signal returned from the sample cell, or the signal is below allowed limits. Check the mirror for contamination.
0x00020000	Aurora H2O has detected a failure in the laser temperature control. Contact the factory for assistance.
0x00040000	The pressure in the Aurora H2O sample cell is greater than 212 kPa (30.75 psia). Verify regulator and flow settings; check for blocked vent line or excessive back pressure.
0x00000000	The Aurora H2O temperature controller is was set beyond its operating limits. Contact the factory for assistance.
0xlyyyzzzz	Extended Error Code

Appendix B. Aurora H2O Ethernet Operation

B.1 Introduction

B.1.1 Connection to the Internet/WAN



WARNING! The Ethernet option provided in the Aurora H2O is designed for use on a limited-access Local Area Network (LAN) protected by a suitable firewall. It should not be operated if exposed to the Internet or other unmanaged Wide Area Network (WAN). Check with your network administrator to determine whether it is safe to connect the Aurora H2O to your network infrastructure.

B.1.2 Default Passwords



WARNING! The Ethernet option in the Aurora H2O is based on technology from Digi International Inc. It includes built-in HTTP (web) and Telnet servers to provide administrative access and control. As shipped from the factory, there are two accounts enabled, with default passwords assigned. These default passwords are public knowledge, and widely distributed.



WARNING! It is **IMPERATIVE** that the *default passwords* be changed before placing the Aurora H2O into service!

B.1.3 Open Ports and Services Warning

Any networked device can compromise the security of the network. It is the users' responsibility to understand the potential risks of attaching a device to the network, and provide adequate protection via firewalls or other means.

The Aurora H2O may use or expose the following ports and services to provide network communications:

- Port 23Telnet management interface for Digi Module, open by default
- Port 68UDP, DHCP, open
- Port 80HTTP management interface for Digi Module, open by default
- Port 502TCP & UDP, Modbus/TCP, open by default
- Port 771Digi RealPort TCP, closed by default
- Port 2101Digi RealPort UDP, closed by default
- Port 2362Digi ADDP (Advanced Device Discovery Protocol), UDP, open by default
- Port 32773UDP, RPC, open

B.1.4 Initial Setup

Before proceeding with this appendix, refer to “*Ethernet Settings*” on page 54 and be sure that all of the setup instructions in that section of been completed.

B.2 Device Discovery

If no DHCP server is present on the LAN, *Device Discovery* will still allow you to identify the Aurora H2O, and begin the configuration process. Confirm the *Media Access Control* (MAC) address displayed with the MAC address label on the Aurora H2O Ethernet connector.

Note: You may now configure the Ethernet option via the Web or Telnet interface. The Web interface is simpler to operate than the Telnet interface, and is recommended in most circumstances.

Use the Open web interface option on the *Device Tasks* menu. The default web browser will launch and will display the Aurora H2O login page shown in *Figure 107* below:

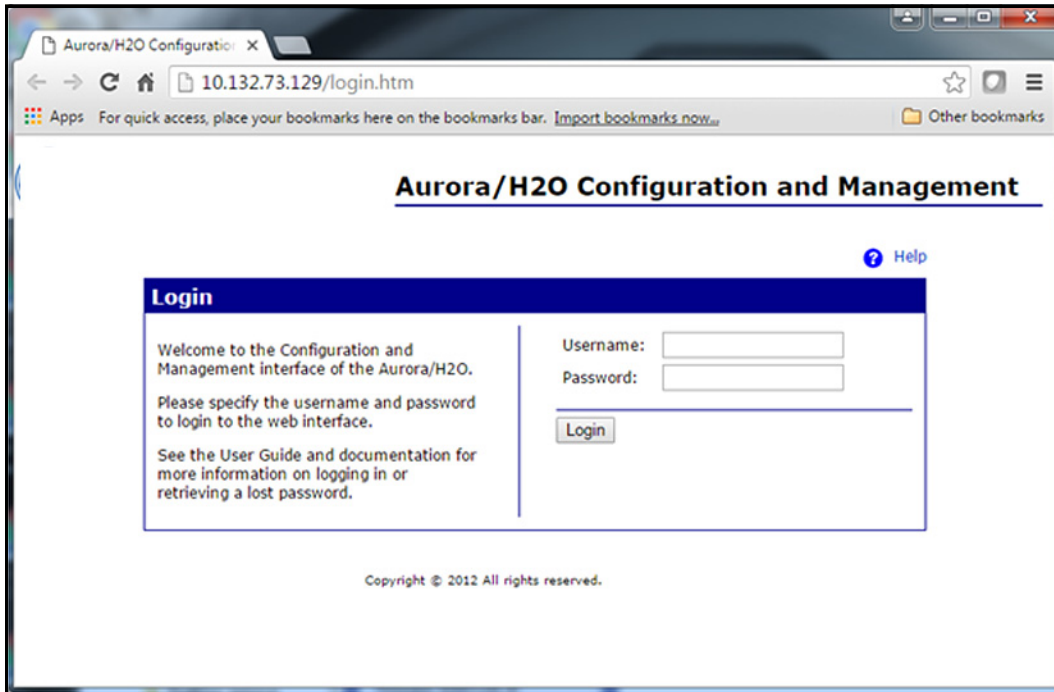

Figure 107: Web Server – Login Page

B.3 User Accounts

As shipped, the Ethernet option supports two accounts:

- Root Account
- Operator Account

B.3.1 The Root Account

The root account allows complete configuration of the Ethernet option. This account should be used only by experienced network administrators. Misuse of the root account could prevent connection to the Aurora H2O, or enable unauthorized access to the Aurora H2O, or possibly expose the network to unauthorized users and exploits.

The default login credentials for the root account are:

- Username: root
- Password: dbps

Note: *If the root password is lost, it is necessary to perform a Factory Reset of the Ethernet module (see “Connecting to an Ethernet LAN” on page 55).*

Once logged in as a root account, the Home page will be displayed as shown in *Figure 108* below:

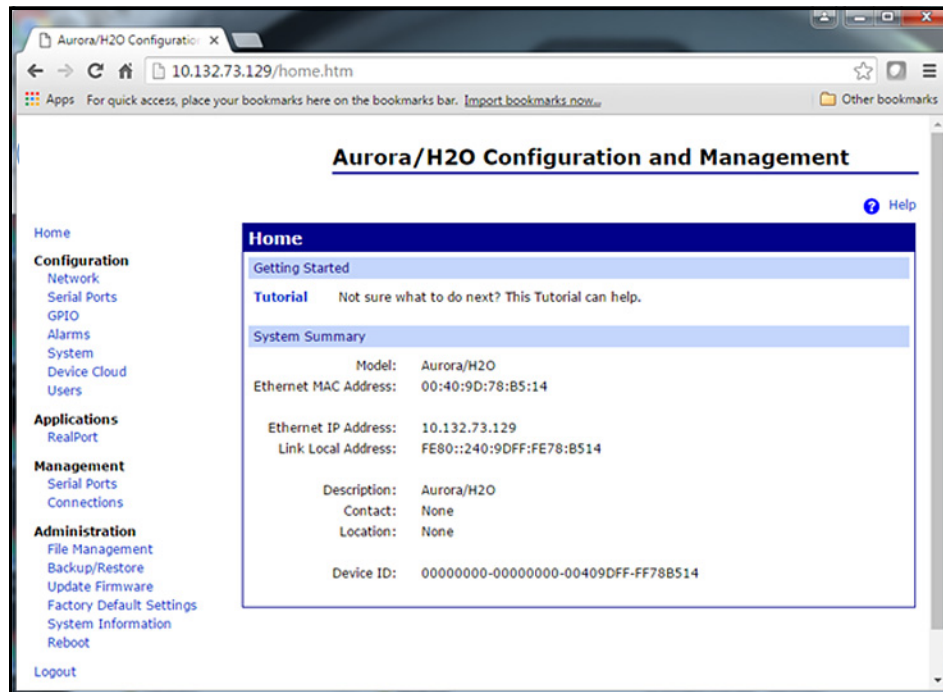

Figure 108: Web Server – Home Page

B.3.1 The Root Account (cont.)

The root password can be changed via the Users menu under Configuration, as shown in *Figure 109* below:

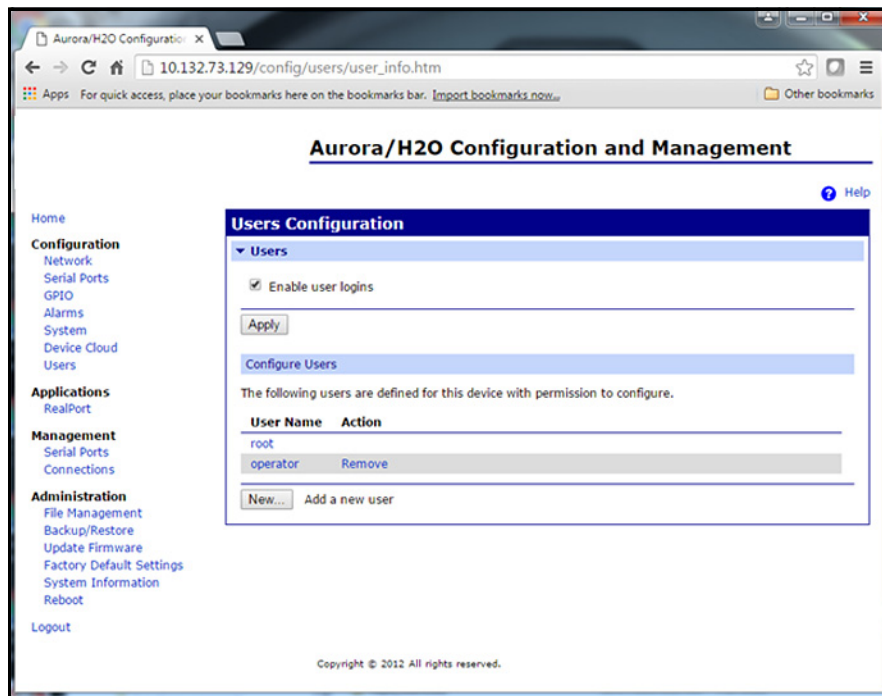

Figure 109: Web Server – User Configuration Page

Click on the root link to enter and confirm a new password for the root account:



WARNING! Record the new root password immediately, and keep it in a safe and secure location!



WARNING! It is NOT POSSIBLE to obtain a lost/forgotten root password! Resetting the root password requires a Factory Reset of the Ethernet module (see *Section 4.2.3 on page 55*).

B.3.1 The Root Account (cont.)

Enter the new password. Then, re-enter the password for confirmation and click Apply (see *Figure 110* below). The password will be changed immediately.

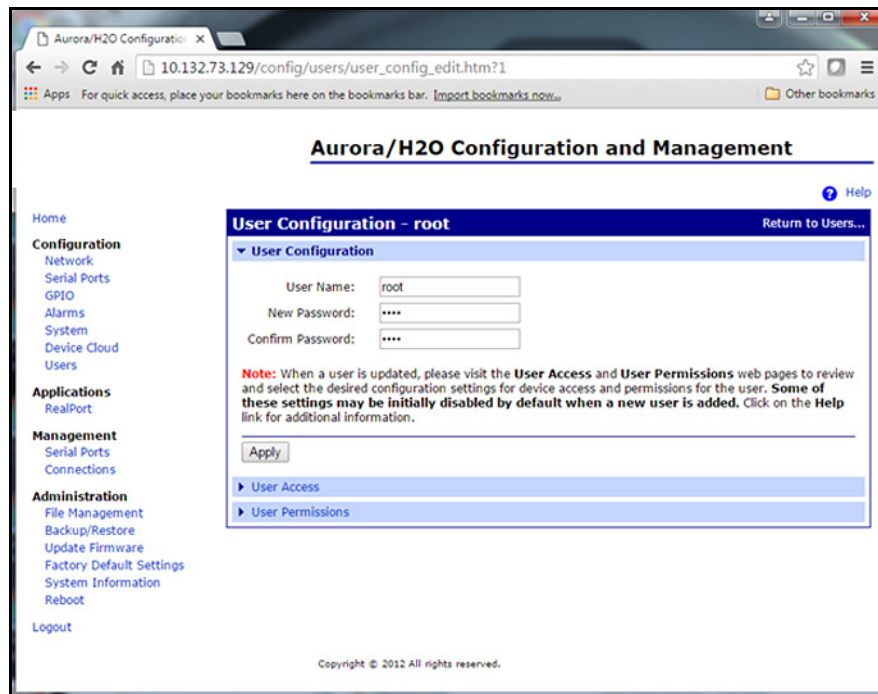

The screenshot shows a web browser window titled "Aurora/H2O Configuration and Management". The address bar shows the URL "10.132.73.129/config/users/user_config_edit.htm?1". The page has a navigation menu on the left with categories: Configuration (Network, Serial Ports, GPIO, Alarms, System, Device Cloud, Users), Applications (RealPort), Management (Serial Ports, Connections), and Administration (File Management, Backup/Restore, Update Firmware, Factory Default Settings, System Information, Reboot, Logout). The main content area is titled "User Configuration - root" and contains a "User Configuration" section with the following fields: "User Name" (root), "New Password" (masked with dots), and "Confirm Password" (masked with dots). Below these fields is a red "Note" stating: "When a user is updated, please visit the **User Access** and **User Permissions** web pages to review and select the desired configuration settings for device access and permissions for the user. **Some of these settings may be initially disabled by default when a new user is added.** Click on the **Help** link for additional information." Below the note is an "Apply" button and two expandable sections: "User Access" and "User Permissions". A "Return to Users..." link is also present in the top right of the main content area. The footer of the page reads "Copyright © 2012 All rights reserved."

Figure 110: Web Server - Changing a Password



WARNING! Record the new root password immediately, and keep it in a safe and secure location!

B.3.2 The Operator Account

The operator account is provided to perform limited configuration management of the Aurora H2O Ethernet option. The operator account has a reduced set of options, permissions, and capabilities. It is designed for use by field personnel performing commissioning or service of the Aurora H2O.

The operator account allows the user to:

- Enable/Disable DHCP
- Specify a static IP, subnet, and gateway IP address
- Modify some of the serial protocol settings
- View the serial port connection status
- View the TCP/IP connection status
- View the Ethernet option firmware version, serial port and network diagnostics

The default login credentials for the operator account are:

- Username:operator
- Password:operator

The operator password should be changed at the earliest opportunity. Only the root account has permission to change the operator password. The steps for changing the operator password are the same as for changing the root password (see *“The Root Account” on page 131*). Select the operator account from the user configuration screen (see *Figure 109 on page 132*), then enter and confirm the new password.



WARNING! Record the new operator password immediately, and keep it in a safe and secure location!

Note: *If the operator password is lost, it can always be reset using the root account.*

Please note that the root account can also create other types of accounts, with different privilege levels. This is not recommended, and should only be performed by experienced operations personnel. Panametrics can only assist with the use of root and operator accounts.

B.4 Communicating by MODBUS via Ethernet

The Aurora H2O Ethernet option supports two communications modes:

- MODBUS/TCP over Ethernet
- MODBUS/RTU over Ethernet

The Aurora H2O and the Ethernet option must be correctly configured for the desired communications mode.

B.4.1 MODBUS/TCP

Note: *As shipped, the Aurora H2O is configured to use the Modbus/TCP Ethernet protocol.*



Select MODBUS/TCP (MB/TCP) from the Aurora H2O menu (Main Menu, Settings..., Ethernet..., Protocol).

To use Modbus/TCP over Ethernet, the Ethernet module must also be configured as follows:

1. Log in to the web user interface. Either the root account or an operator account may be used to configure the module.
2. Choose *Serial Ports* from the *Configuration Menu*. Verify that *Industrial Automation* is selected as the *Profile* (see *Figure III* below).
3. Click on the *Port 1* link to display the current *Profile*.

Serial Port Configuration			
Port	Description	Profile	Serial Configuration
Port 1	High Speed UART 2	Industrial Automation	230400 8N1

Figure III: MB/TCP Serial Port 1 Profile

4. If the information displayed is not correct, change the profile as required.

B.4.2 MODBUS/RTU

To change the default MB/TCP Ethernet protocol and use the MB/RTU protocol instead, follow the instructions in this section.



Select MODBUS/RTU (MB/RTU) from the Aurora H2O menu (Main Menu, Settings..., Ethernet..., Protocol).

To use Modbus/RTU over Ethernet, the Ethernet module must also be configured as follows:

1. Log in to the web user interface. Either the root account or an operator account may be used to configure the module.
2. Choose *Serial Ports* from the *Configuration Menu*. Verify that *RealPort* is selected as the *Profile* (see *Figure 112* below).
3. Click on the *Port 1* link to display the current *Profile*.

Serial Port Configuration			
Port	Description	Profile	Serial Configuration
Port 1	High Speed UART 2	RealPort	N/A

Figure 112: MB/RTU Serial Port 1 Profile

4. If the information displayed is not correct, change the profile as required.

B.5 Using TELNET for Configuration

If a web browser is not available or not practical in a given situation, the Telnet server can be used to perform configuration changes. Telnet is a text-based system that provides a *Command Line Interface* (CLI) to the Ethernet module. Microsoft Windows provides a Telnet client, or terminal emulators such as PuTTY or Tera Term can be used.

Note: Starting with Windows 7, the Telnet client is disabled by default.

To enable Telnet command line utilities, proceed as follows:

1. Click Start > Control Panel.
2. Click Programs and Features.
3. Click Turn Windows features on or off.
4. In the Windows Features dialog box, check the Telnet Client check box (see Figure 113 below).
5. Click OK and the system installs the appropriate files. This will take a few seconds to a minute.

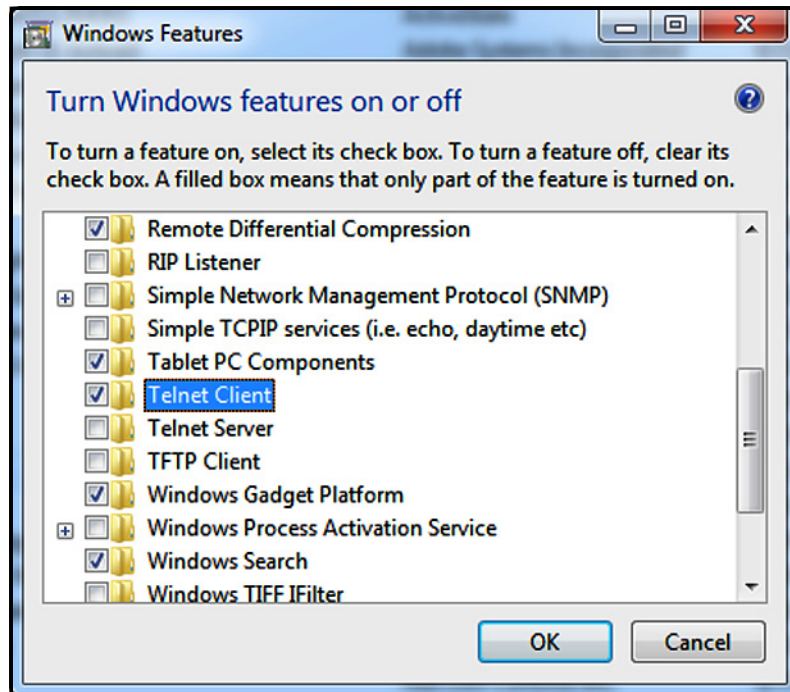

Figure 113: Windows Features Dialog Box

B.6 Using the MS Windows Telnet Client

1. At a Windows command prompt, enter telnet to run the Telnet client (see *Figure 114* below).

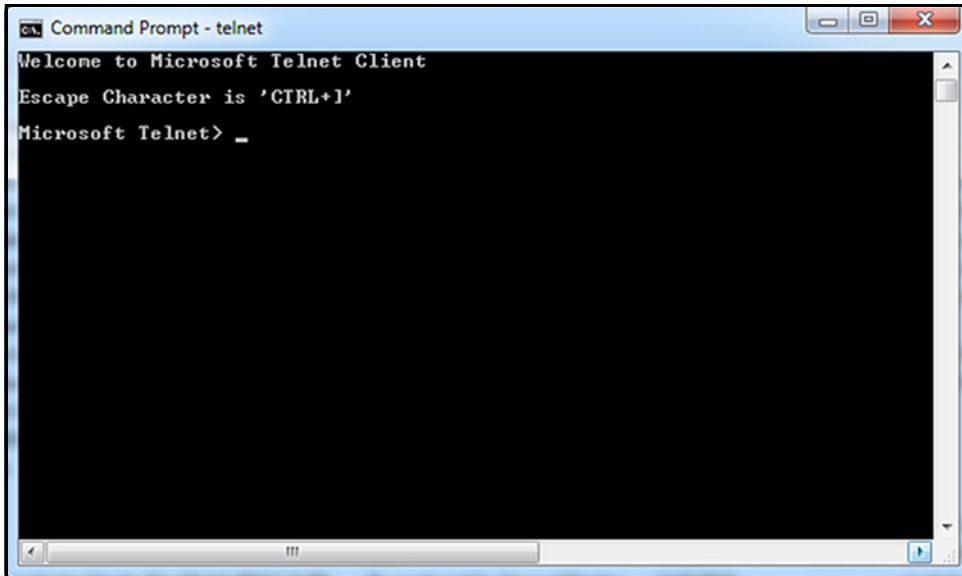

Figure 114: Telnet Client

2. To connect to the module, use the OPEN command with the IP address of the module (see *Figure 115* below).

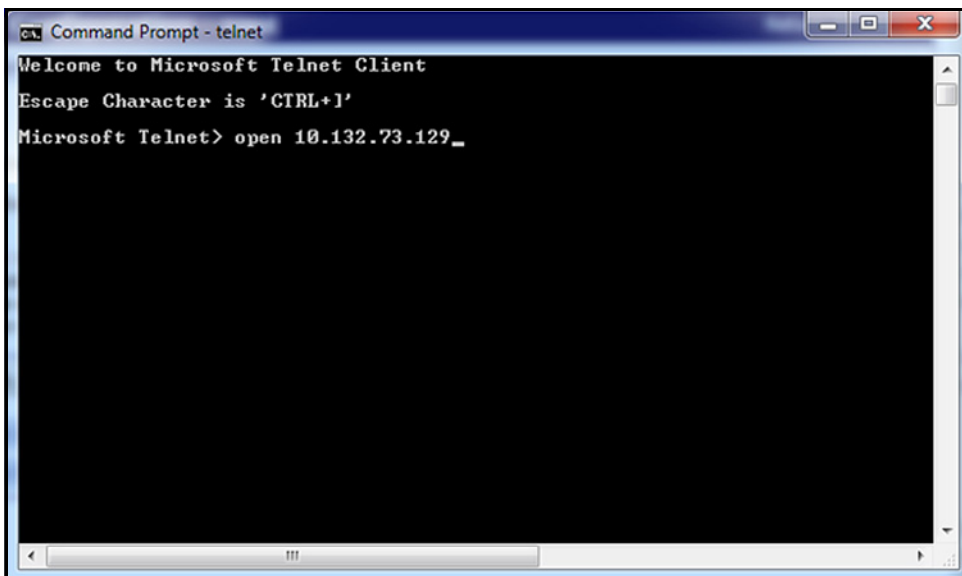
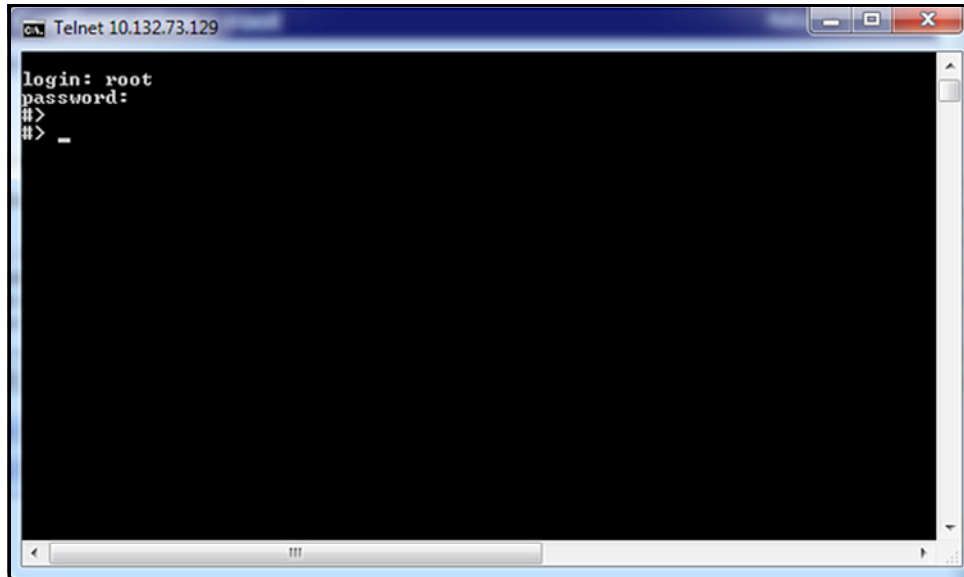

Figure 115: Telnet OPEN Command

B.6 Using the MS Windows Telnet Client (cont.)

- At the module login: prompt, log in using the root account. Your password will not be echoed back. Upon successful login, the #> module prompt is displayed (see *Figure 116* below).

Note: For security reasons, the operator account only supports the http (web) server, and cannot be used via telnet.



```

ca Telnet 10.132.73.129
login: root
password:
#>
#> _

```

Figure 116: Telnet Login

- Enter the set profile command to view the current setting (see *Figure 117* below). To change the profile, enter the command again and specify the profile desired:
 - set profile profile=realport(for Modbus/RTU), or
 - set profile profile=ia(for Modbus/TCP)

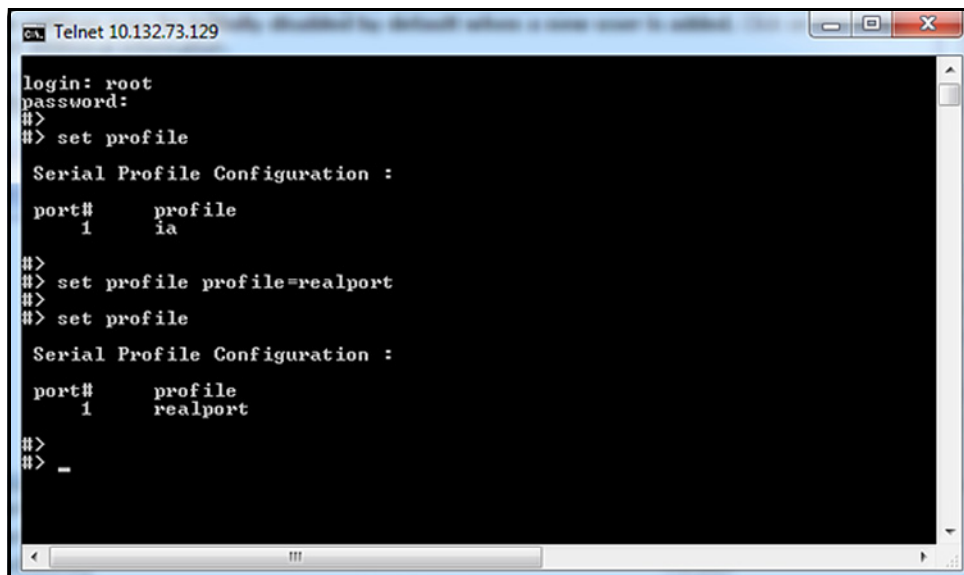

```

ca Telnet 10.132.73.129
login: root
password:
#>
#> set profile

Serial Profile Configuration :

port#    profile
  1      ia

#>
#> set profile profile=realport
#>
#> set profile

Serial Profile Configuration :

port#    profile
  1      realport

#>
#> _

```

Figure 117: Telnet Set Profile Command

B.6 Using the MS Windows Telnet Client (cont.)

3. A list of other available commands and their usage can be displayed by entering help or ? at the #> prompt (see *Figure 118* below).
4. To disconnect the telnet session, enter quit or exit. At the Microsoft Telnet> prompt, enter quit again to return to the Windows command prompt.

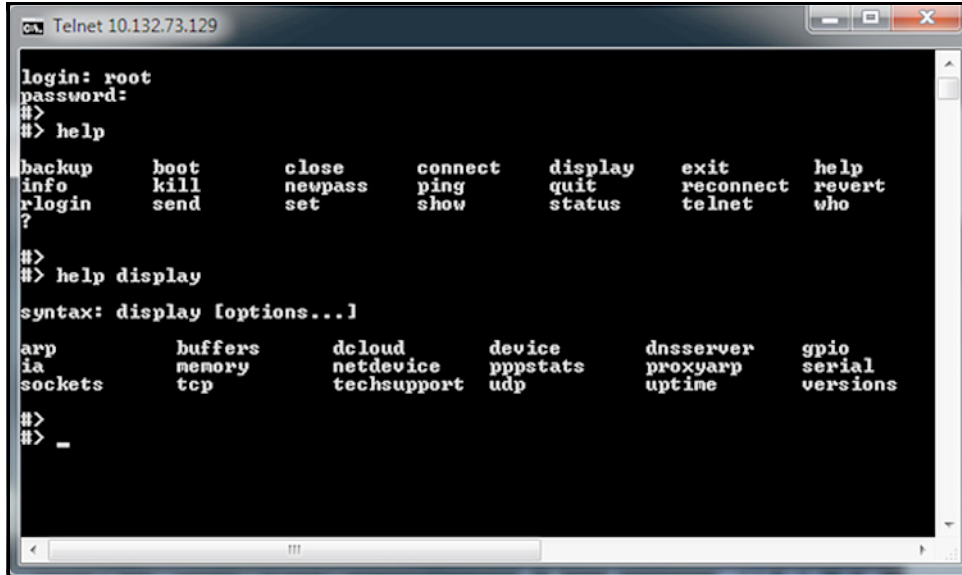

```
Telnet 10.132.73.129
login: root
password:
#>
#> help
backup      boot        close      connect    display    exit        help
info       kill        newpass    ping       quit       reconnect   revert
rlogin     send       set        show      status     telnet     who
?
#>
#> help display
syntax: display [options...]
arp         buffers     dcloud     device     dnserver   gpio
ia          memory     netdevice  pppstats  proxyarp   serial
sockets    tcp        techsupport  udp       uptime    versions
#>
#> _
```

Figure 118: Telnet Help Command

	A			M
AuroraView			Magnetic Stylus	37
Capabilities		77	Maintenance	101
Datalogging with		93	Menu Map	75, 76
Installing		78	Menus, Accessing	39
Requirements		77	Mirror, Cleaning	101
Scan Plots		94	Modbus	
Starting		85	RTU/RS485 Communications	121
Trend Plots		94	Mounting	16, 31
Trend Tabular Data		94		
Using Main Menus		87		
	B			N
Bill of Materials		13	Numeric Values, Entering	39
	C			O
Clock, Resetting		63	Offset Values, Adjusting	57
Comm Port Settings		51	Operation	
Connections		32	Sample System	33
	D		Theory of	2
Default Display		37	Outline	31
Display				P
Blank		115	Parts	101
Dim or Hard to Read		115	Pressure Settings, Resetting	65
Locking/Unlocking		73	Programming	
Setting Up		40	Advanced Features	51
Display, Default		37	General	33
	E		Menu Map	75, 76
Electrical Connections		25		
	F			R
Features		1	Regional Settings	67
Filter Element, Replacing		7, 112	Replacing the Filter Element	7, 112
	G			S
Gas Molecular Weight, Adjusting		59	Safety	
	H		Auxiliary Equipment	iii
Heater			General Issues	iii
EU/ATEX		5, 8	Personal Equipment	iv
USA/CAN		4, 8	Sample System	
	I		Operation	33
Indicator Lights		37	Services	iii
Insertion Probe/Regulator			Settings, Regional	67
Description		16	Site Location	14
Installation		17	Spare Parts	101
Setting the Pressure		24	Specifications	9
Installation			Starting Up	40
Choosing a Site		14	Stylus, Magnetic	37
Mounting		16	System	
Installation, System		13	Information	71
	K			T
Keypad			Troubleshooting	115
Lock-Out Switch		38	Blank Display	115
Unlocking		38	Display Dim or Hard to Read	115
	L		No Flow Measurement	117
Lights, Indicator		37	Status Messages and Indicators	115
Low Voltage Directive		16	Using a Moisture Standard	118
			Using a Portable Hygrometer	117
			Verifying Performance	117
			Typographical Conventions	iii

U

Unpacking 13

W

Wiring 25, 32

Wiring Diagram

EU/ATEX Heater 8

USA/CAN Heater 8

Warranty

Each instrument manufactured by Panametrics is warranted to be free from defects in material and workmanship. Liability under this warranty is limited to restoring the instrument to normal operation or replacing the instrument, at the sole discretion of Panametrics. Fuses and batteries are specifically excluded from any liability. This warranty is effective from the date of delivery to the original purchaser. If Panametrics determines that the equipment was defective, the warranty period is:

- One year from delivery for electronic or mechanical failures
- One year from delivery for sensor shelf life

If Panametrics determines that the equipment was damaged by misuse, improper installation, the use of unauthorized replacement parts, or operating conditions outside the guidelines specified by Panametrics, the repairs are not covered under this warranty.

The warranties set forth herein are exclusive and are in lieu of all other warranties whether statutory, express or implied (including warranties or merchantability and fitness for a particular purpose, and warranties arising from course of dealing or usage or trade).

Return Policy

If a Panametrics instrument malfunctions within the warranty period, the following procedure must be completed:

1. Notify Panametrics, giving full details of the problem, and provide the model number and serial number of the instrument. If the nature of the problem indicates the need for factory service, Panametrics will issue a RETURN AUTHORIZATION NUMBER (RAN), and shipping instructions for the return of the instrument to a service center will be provided.
2. If Panametrics instructs you to send your instrument to a service center, it must be shipped prepaid to the authorized repair station indicated in the shipping instructions.
3. Upon receipt, Panametrics will evaluate the instrument to determine the cause of the malfunction.

Then, one of the following courses of action will then be taken:

- If the damage is covered under the terms of the warranty, the instrument will be repaired at no cost to the owner and returned.
- If Panametrics determines that the damage is not covered under the terms of the warranty, or if the warranty has expired, an estimate for the cost of the repairs at standard rates will be provided. Upon receipt of the owner's approval to proceed, the instrument will be repaired and returned.

[no content intended for this page]

Customer Support Centers

U.S.A.

The Boston Center
1100 Technology Park Drive
Billerica, MA 01821

U.S.A.

Tel: 800 833 9438 (toll-free)
978 437 1000

E-mail: panametricstechsupport@bakerhughes.com

Ireland

Sensing House
Shannon Free Zone East
Shannon, County Clare
Ireland

Tel: +353 (0)61 470200

E-mail: panametricstechsupport@bakerhughes.com

Copyright 2023 Baker Hughes company.

This material contains one or more registered trademarks of Baker Hughes Company and its subsidiaries in one or more countries. All third-party product and company names are trademarks of their respective holders.

BH003C11 EN C

Baker Hughes ™