

# Type T Series Operation Manual

for T, T-1, T-1-CPF, T-2, T-3, and Systems F



# Contents

<b>Overview</b> .....	<b>1</b>
Introduction .....	1
Features and Parts Lists .....	3
<b>Safety Instructions</b> .....	<b>6</b>
Warnings, Cautions, and Notes .....	6
<b>Setup</b> .....	<b>7</b>
Assembly .....	7
<b>Operation and Maintenance</b> .....	<b>9</b>
Generating Pressure .....	9
Priming .....	10
<b>Connection Diagram</b> .....	<b>13</b>
Crystal Reference Indicators .....	13
<b>Specifications</b> .....	<b>14</b>
<b>Support</b> .....	<b>15</b>
Troubleshooting .....	15
Fitting Kits and Spare Parts .....	19
Appendix A: Assembly Drawings and Parts Lists .....	21
Contact Us .....	28
Returning product to AMETEK .....	28
Warranty .....	28

# Overview

## INTRODUCTION

The Type T Series hand pump, mounted on a drip pan with a manifold assembly, is capable of producing pressures up to 1000 bar/15 000 psi.

These units are self-contained pressure sources designed to test instruments. They may be used to calibrate pressure gauges or to set hydraulic relief valves and pressure switches. These units produce pressure to test components or systems, and work independently of other pressure sources. CPF<sup>♦</sup> versions include [Crystal Pressure Fittings \(CPF\)](#), which allow users to produce leak-free seals without tools or thread tape. CPF fittings also include a self-venting weep hole to help assure a safe disconnection from a pressurized system.

<sup>♦</sup>U.S. Patent No. 8,794,677

T, T-1, and T-2 pumps<sup>1</sup> may be ordered as part of a Pump System, complete with a JOFRA or Crystal Pressure Indicator. T-3 pumps ship as part of a complete comparator testing kit, including four analog test gauges and necessary mounting tools and fittings, all housed in a rugged metal carrying case. For more details on T-3 comparator testing kits, refer to [T-3 Pumps for Hydraulic Comparator Kits on page 2](#).

All Type T Series Pump Systems include the most commonly used pressure fittings, seals, etc., all packaged in a carrying case with a custom insert.

<sup>1</sup> T designates a pump only. T-1 designates a pump with a manifold and tools. T-2 designates a pump with manifold, tools, and a carrying case.

### T, T-1, and T-2 Pumps

	Pressure Medium	O-rings	Pump System
T-1	Water <sup>*</sup>	Buna-N	FWB
T-1-CPF	Oil or Water <sup>*</sup>	Viton <sup>®</sup>	FOV or FWV
T-1/VITON	Water <sup>*</sup>	Viton <sup>®</sup>	FWV
T-1/EPT	Water <sup>*</sup>	EPT	FWE
T-1/OIL	Oil	Buna-N	FOB
T-1/OIL/VITON	Oil	Viton <sup>®</sup>	FOV
T-1/OIL/EPT	Oil	EPT	FOE

<sup>\*</sup>Water is a 50/50 mixture of water and Isopropyl Alcohol.



Type T Series Pump System

## T-3 Pumps for Hydraulic Comparator Kits

### ► With 160, 600, 5000, and 10 000 psi Gauges

	Cal. Certification with Data	Pressure Medium	O-rings
T-3	No	Water *	Buna-N
T-3/EPT	No	Water *	EPT
T-3/VITON	No	Water *	VITON
T-3/OIL	No	Oil	Buna-N
T-3/OIL/EPT	No	Oil	EPT
T-3/OIL/VITON	No	Oil	VITON
T-3/C	Yes	Water *	Buna-N
T-3/C/EPT	Yes	Water *	EPT
T-3/C/VITON	Yes	Water *	VITON
T-3/C/OIL	Yes	Oil	Buna-N
T-3/C/OIL/EPT	Yes	Oil	EPT
T-3/C/OIL/VITON	Yes	Oil	VITON

### ► With 30, 600, 3000, and 5000 psi Gauges

	Cal. Certification with Data	Pressure Medium	O-rings
T-3A	No	Water *	Buna-N
T-3A/EPT	No	Water *	EPT
T-3A/VITON	No	Water *	VITON
T-3A/OIL	No	Oil	Buna-N
T-3A/OIL/EPT	No	Oil	EPT
T-3A/OIL/VITON	No	Oil	VITON
T-3A/C	Yes	Water *	Buna-N
T-3A/C/EPT	Yes	Water *	EPT
T-3A/C/VITON	Yes	Water *	VITON
T-3A/C/OIL	Yes	Oil	Buna-N
T-3A/C/OIL/EPT	Yes	Oil	EPT
T-3A/C/OIL/VITON	Yes	Oil	VITON

### ► With 2, 42, 210, and 350 kg/cm<sup>2</sup> Gauges

	Cal. Certification with Data	Pressure Medium	O-rings
T-3AM	No	Water *	Buna-N
T-3AM/EPT	No	Water *	EPT
T-3AM/VITON	No	Water *	VITON
T-3AM/OIL	No	Oil	Buna-N
T-3AM/OIL/EPT	No	Oil	EPT
T-3AM/OIL/VITON	No	Oil	VITON
T-3AM/C	Yes	Water *	Buna-N
T-3AM/C/EPT	Yes	Water *	EPT
T-3AM/C/VITON	Yes	Water *	VITON
T-3AM/C/OIL	Yes	Oil	Buna-N
T-3AM/C/OIL/EPT	Yes	Oil	EPT
T-3AM/C/OIL/VITON	Yes	Oil	VITON

### ► With 200, 4000, 21000, and 35 000 kPa gauges

	Cal. Certification with Data	Pressure Medium	O-rings
T-3AN	No	Water *	Buna-N
T-3AN/EPT	No	Water *	EPT
T-3AN/VITON	No	Water *	VITON
T-3AN/OIL	No	Oil	Buna-N
T-3AN/OIL/EPT	No	Oil	EPT
T-3AN/OIL/VITON	No	Oil	VITON
T-3AN/C	Yes	Water *	Buna-N
T-3AN/C/EPT	Yes	Water *	EPT
T-3AN/C/VITON	Yes	Water *	VITON
T-3AN/C/OIL	Yes	Oil	Buna-N
T-3AN/C/OIL/EPT	Yes	Oil	EPT
T-3AN/C/OIL/VITON	Yes	Oil	VITON

### ► With 11, 42, 350, and 700 bar gauges

	Cal. Certification with Data	Pressure Medium	O-rings
T-3/BARS	No	Water *	Buna-N
T-3/BARS/EPT	No	Water *	EPT
T-3/BARS/VITON	No	Water *	VITON
T-3/BARS/OIL	No	Oil	Buna-N
T-3/BARS/OIL/EPT	No	Oil	EPT
T-3/BARS/OIL/VITON	No	Oil	VITON
T-3/BARS/C	Yes	Water *	Buna-N
T-3/BARS/C/EPT	Yes	Water *	EPT
T-3/BARS/C/VITON	Yes	Water *	VITON
T-3/BARS/C/OIL	Yes	Oil	Buna-N
T-3/BARS/C/OIL/EPT	Yes	Oil	EPT
T-3/BARS/C/OIL/VITON	Yes	Oil	VITON

\* Water is a 50/50 mixture of water and Isopropyl Alcohol.



T-3 Hydraulic Comparator Testing Kit

## FEATURES AND PARTS LISTS

Type T Series hand pumps may be ordered with either oil or a water/alcohol mixture as the pressure medium. There are three available seal packages for the system: Buna-N, Viton®, and EPT.

All Type T Series hand pumps feature a vent valve, and dual volume control for rapid pressure increase at lower pressures and easier pumping at higher pressures. T-1, T-2, and T-3 models include a dual pressure port manifold with fine adjust, plus replacement o-rings and a set of service tools.

Refer to [Figure 3 on page 25](#) for more details on the included tools.

### T-1 and T-2 – Included Parts

#### ► Reference and Device Under Test Pressure Ports

Part Number	Description
T-134	15/16-20 Male to 1/4" NPT Female Adapter
T-135	15/16-20 Male to 1/2" NPT Female Adapter

### T-1-CPF – Included Parts

#### ► Reference and Device Under Test Pressure Ports

Part Number	Description
5255	CPF Male to 15/16-20 Male Adapter (2)
4715	MP Female to 1/4" Female NPT Fitting

### T-3 – Included Parts

#### ► Reference and Device Under Test Pressure Ports

Part Number	Description
T-134	15/16-20 Male to 1/4" NPT Female Adapter
T-135	15/16-20 Male to 1/2" NPT Female Adapter
–	Set of 4 Test Gauges*

\* For more details refer to [T-3 Pumps for Hydraulic Comparator Kits on page 2](#) and to [Figure 4 on page 26](#).

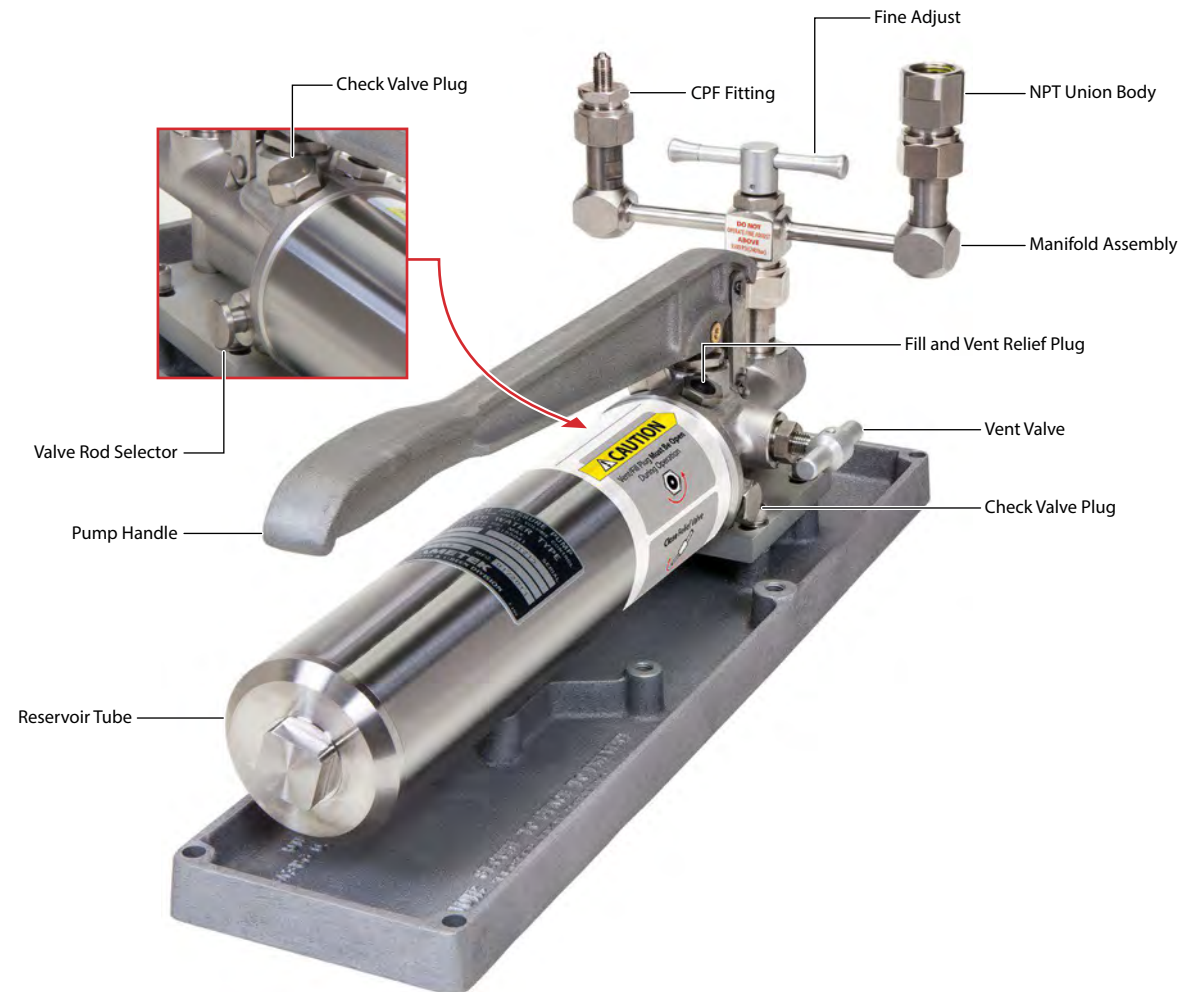

## Parts Included with Pump Systems for JOFRA Reference Indicators



Part Number	Description	System F					
		FWB (T-1)	FWV (T-1/Viton)	FWE (T-1/EPT)	FOB (T-1/Oil)	FOV (T-1/Oil/Viton)	FOE (T-1/Oil/EPT)
T-134	15/16-20 Male to 1/4" NPT Female Adapter	■	■	■	■	■	■
T-135	15/16-20 Male to 1/2" NPT Female Adapter	■	■	■	■	■	■
T-786	1/4" NPT Male to 1/4" BSP Female Fitting	■	■	■	■	■	■
127400 *	1/4" NPT Male to 1/8" BSP Male Fitting	■	■	■	■	■	■
127401 *	1/4" BSP Female to 1/8" BSP Male Fitting	■	■	■	■	■	■
127402 *	1/8" Bonded Seals	■	■	■	■	■	■
60R120	1/4" Bonded Seals	■	■	■	■	■	■
404203 *	Test Leads; Red & Black, including clips	■	■	■	■	■	■
60I104	Pack Tape (1 roll)	■	■	■	■	■	■
124004	Shoulder Strap	■	■	■	■	■	■
124304	Aluminum Carrying Case	■	■	■	■	■	■



\* Included with HPC.

## Hydraulic Fluid

Type T Series Pump Systems are *only* available delivered empty. You will still need to specify what fluid type you are going to use (for example; FOV for Oil or FWV for Water).

## Ordering a Pump System

Any Type T Series Pump System may be ordered with or without a reference indicator. The table below provides an explanation of the Pump System ordering scheme when ordering a system without an indicator. For details on ordering the Pump Systems with an indicator, see the indicator datasheet.

Reference Indicator	Reference Indicator Included	Pump System
HPC500 Series ... HPC500	No... -NONE	System F (T-1) .....-FWB
		System F (T-1/Viton).....-FWV
		System F (T-1/EPT) .....-FWE
		System F (T-1/Oil) .....-FOB
		System F (T-1/Oil/Viton) ...-FOV
		System F (T-1/Oil/EPT).....-FOE

### ▶ SAMPLE PART NUMBERS

- HPC-NONE-FWB ..... System F pump system (for HPC500), for use with water.
- HPC-NONE-FOE ..... System F pump system (for HPC500), for use with oil.
- HPC500-700G-FOB..... System F pump system for use with oil with a 0.82 to 35 bar HPC500 included.

## Parts Included with Pump Systems for Crystal Reference Indicators



**System F**  
FOV and FWV  
(T-1-CPF)

Part Number	Description	
5255	CPF Male to 15/16-20 Male Adapter	■ (2)
MPF15K-1/4FPT	CPF Female to 1/4" NPT Female Fitting	■
MPF-1/4BSPF	CPF to 1/4" BSP Female Fitting	■
MPF-1/8MPT *	1/8" MPT Fitting (for 30 Series Calibrator)	■ (2)
60R120	1/4" Bonded Seals	■ (5)
1351 *	Test Leads; Red & Black, including clips	■
5249	Protective Vinyl Cap	■ (4)
601104	Pack Tape (1 roll)	■
124004	Shoulder Strap	■
124304	Aluminum Carrying Case	■

\* The MPF-1/8MPT fittings and 1351 Test Leads are included *only* with Pump Systems for the 30 Series Calibrator.

## Hydraulic Fluid

Type T Series Pump Systems are *only* available delivered empty. You will still need to specify what fluid type you are going to use (for example; FOV for Oil or FWV for Water).



## Ordering a Pump System

Any Type T Series Pump System may be ordered with or without a reference indicator. The table below provides an explanation of the Pump System ordering scheme when ordering a system without an indicator. For details on ordering the Pump Systems with an indicator, see the indicator datasheet.

Reference Indicator	Reference Indicator Included	Pump System	Liquid
nVision . . . . . NV	No. . . -NONE	System F (T-1-CPF) . . . -FOV	Drained. . . -E
30 Series. . . . . IS30		System F (T-1-CPF) . . . -FWV	
XP2i . . . . . XP2i			
m1. . . . . M1			
HPC40 Series . . . HPC40			

### ► SAMPLE PART NUMBERS

NV-NONE-FOV-E . . . . . System F pump system (for nVision) drained of fluid, for use with oil.

IS30-NONE-FWV-E . . . . . System F pump system (for 30 Series) drained of fluid, for use with water.

15KPSIXP2i-FWV-E . . . . . System F pump system, drained, for use with water, with a 15 000 psi XP2i gauge included.

# Safety Instructions

## WARNINGS, CAUTIONS, AND NOTES

---

### ! WARNINGS:

- Do not connect any external pressure source to this instrument. This unit is designed to test pressure measuring devices connected to the manifold only. Pressure from an external source can result in explosion of the liquid reservoir and possible bodily injury.
- This pump produces pressure up to 15 000 psi. The pressure rating of tubing and fittings used to connect the pump to the test device should exceed 15 000 psi.
- Do not operate above 15 000 psi/1000 bar.

### ! CAUTIONS:

- To prevent the reservoir from overflowing upon venting, the volume of oil pumped should never exceed the reservoir volume.
- Never operate the pump without fluid in the reservoir. The piston and o-rings require lubrication.
- Do not operate the fine adjust knob above 3500 psi.
- The vent plug must be open to operate this instrument.

**Notes:** All wetted parts are stainless steel, Monel, or Buna-N. Optional o-ring materials are Viton and EPT .



# Setup

## ASSEMBLY

- 1 Open the vent valve.

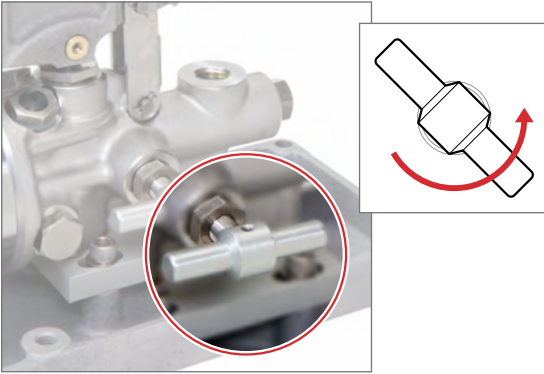

- 2 Attach the pressure manifold to the pump body.



**3** Close the vent valve.

**Note:** If using the T-1-CPF, fill with test fluid through the gauge connections. This may take approximately 15 minutes.

**Note:** It may be necessary to prime the pump, particularly for first time use, or if the pump has been inactive for an extended period of time. Refer to [Priming on page 10](#) for instructions on priming the pump.

**4** Pull the pump handle to the top of its stroke.

**5** Pull out the valve rod selector to select the low pressure/high volume setting.

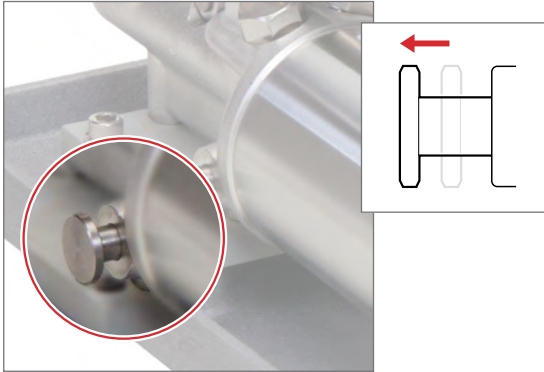

**6** Gently operate the pump handle until test fluid fills the top of the pressure ports on the pressure manifold.

**Note:** Lightly tap the manifold to make sure that any air bubbles sticking to the walls or in low flow areas are released to float to the surface.

**7** Attach the reference instrument and the device under test to the manifold.

**Note:** If CPF Fittings are used in your pressure system, remaining air can be purged by applying 10 psi or less and loosening the CPF fitting closest to the pressure device. When fluid and air escape from the CPF weep hole, that portion of the system is purged. Repeat this process for each pressure device in the pressure system which is connected to a CPF fitting.

**! CAUTION:** Always choose a reference instrument with a range equal to or greater than the range of the device under test.

**8** Ensure all connections are tight and leak free.

# Operation and Maintenance

## GENERATING PRESSURE

**Note:** It may be necessary to prime the pump, particularly if the pump has been inactive for an extended period of time. Refer to [Priming on page 10](#) for instructions on priming the pump.

- 1 Check that the vent fill plug is fully open by turning it counter-clockwise.
- 2 Open the vent valve.

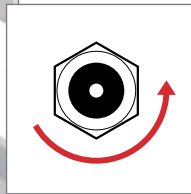
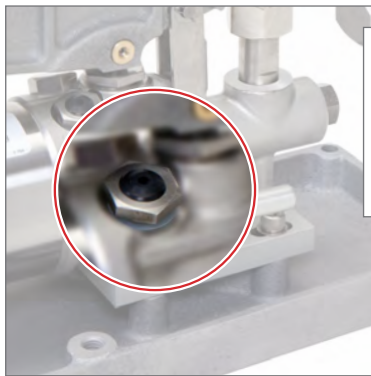

Open the vent plug...

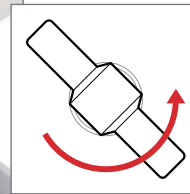

then open the vent valve.

- 3 Set the valve rod selector to control your desired fluid output volume.

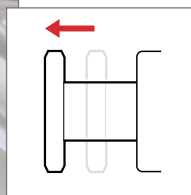

Low Pressure/  
High Volume

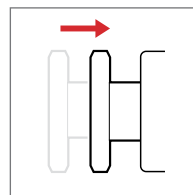

High Pressure/  
Low Volume

**CAUTION:** Only move the valve rod selector while the pump handle is stationary, in the up position.

**Note:** With the valve rod in the “out” position, fluid flow will be at maximum and the maximum achievable pressure will be 1000 psi. To exceed 1000 psi, push the valve rod in.

- 4 Zero the reference indicator and the device under test.
- 5 Close the vent valve.
- 6 Operate the pump handle to achieve a system pressure close to, but less than, your desired target pressure.
- 7 Pull the pump handle to the top of its stroke.
- 8 Push in the valve rod selector to select the high pressure/low volume setting.
- 9 Wait for the pressure to stabilize.
- 10 Carefully push down the pump handle to achieve the target pressure.

**Note:** Below 3500 psi, you may also use the fine adjust knob for small pressure adjustments.

- 11 After obtaining your readings, open the vent valve to vent the system.

**! WARNING:** The device under test and the reference indicator should only be removed when there is no pressure in the system.

## PRIMING

All pumps are thoroughly tested at the factory before shipment. One of the most common difficulties encountered is the loss of prime, which is evidenced by an inability to build pressure. This is caused by entrapped air in the reservoir, which may collect in the high pressure/low volume check valve. When this occurs, the pump will not develop pressure with the valve rod selector positioned in, to the high pressure/low volume setting. The following priming procedure will correct the condition.

**Note:** For priming purposes, *pump vigorously* with full strokes of the hand lever.

**Note:** Verify the pump reservoir has sufficient fluid.

### ► To Prime the Pump

- 1 Connect a reference indicator with a pressure range of at least 5000 psi to the manifold.

**! CAUTION:** Significant pressure can develop during the priming process. Therefore, any device mounted to the manifold should have a range of at least 300 bar / 5000 psi. Alternately, all devices may be removed, and the manifold plugged.

- 2 Plug the remaining port of the manifold.



- 3 Pull the pump handle to the top of its stroke.
- 4 Open the vent valve.
- 5 Pull out the valve rod selector to select low pressure/high volume.

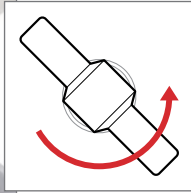
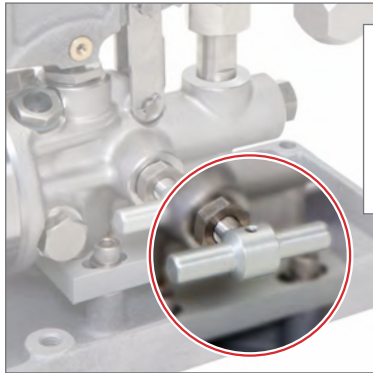

Open the vent valve...

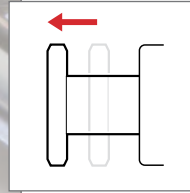
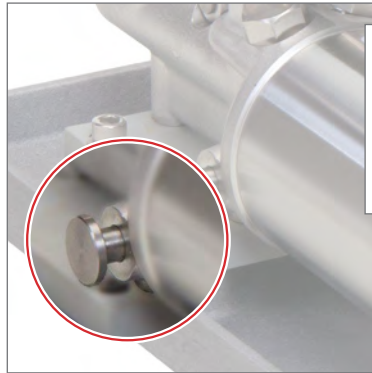

then select low pressure/high volume.

- 6 Pump ten full strokes.
- 7 Close the vent valve
- 8 Continue pumping to verify the low pressure/high volume setting operates properly and that the pump holds pressure.
- 9 Open the vent valve.
- 10 Pump ten more strokes.
- 11 Remove the high pressure/low volume check valve plug.

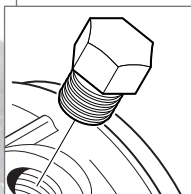
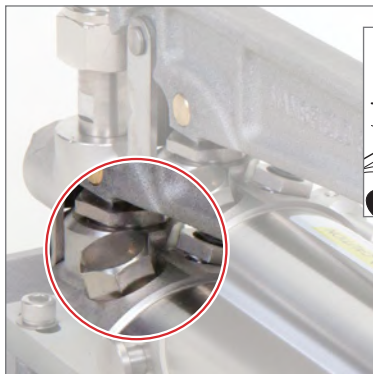

- 12 Slowly pump two and one-half strokes, positioning the pump lever at approximately 45 degrees, halfway through its stroke.
- 13 Allow system fluid to flow out of the high pressure check valve, flushing entrapped air.
- 14 Examine the port for air bubbles which may adhere to the threads or parts.  
**Note:** If air bubbles are present, repeat steps 12 through 14 until no more air bubbles appear.
- 15 Replace the high pressure/low volume check valve plug and tighten partially.
- 16 Use slight pressure on the hand lever to push system fluid past the high pressure/low volume check valve plug to ensure complete purging of the valve port.
- 17 Tighten the high pressure/low volume check valve plug.
- 18 Operate the pump handle until pumping becomes difficult.
- 19 Raise the pump handle.
- 20 Push in the valve rod selector to the high pressure/low volume position.

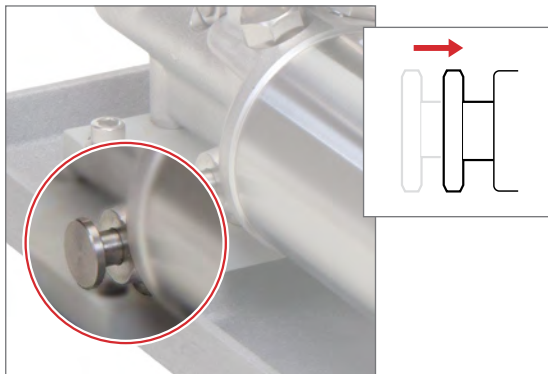

- 21 Resume pumping to verify the pump is operating properly.

**Note:** If the high pressure/low volume setting does not operate properly, there is more air trapped in the high pressure/low volume check valve. The priming procedure must be repeated.

# Connection Diagram

## CRYSTAL REFERENCE INDICATORS



### ► CPF Fittings

NPT MALE			
	MPF-1/8QTM	1/8" Quick Test NPT Male	10
	MPF-1/8MPT	1/8" NPT Male	10
	MPF-1/4QTM	1/4" Quick Test NPT Male	10
	MPF-1/4MPT	1/4" NPT Male	10
Additional NPT sizes available in non-CPF MP adapters			
NPT FEMALE			
	MPF-1/8QTF	1/8" Quick Test NPT Female	10
	MPF-1/4QTF	1/4" Quick Test NPT Female	10
	MPF-1/4FPT	1/4" NPT Female	10
	MPF-1/2QTF	1/2" Quick Test NPT Female	5
Additional NPT sizes available in non-CPF MP adapters			
BSP			
	MPF-1/8BSPF	G 1/8" Female	10
	MPF-1/4BSPF	G 1/4" Female	10
	MPF-3/8BSPF	G 3/8" Female	10
	MPF-1/2BSPF	G 1/2" Female	10
TRANSMITTER			
	MPF-5/16TRM	for Foxboro, Rosemount, and Yokogawa	5
	MPF-1/4TRM	for Honeywell	5
TUBE			
	MPF-1/4TBM	1/4" Tube Male	5
	MPF-3/8TBM	3/8" Tube Male	5
	MPF-1/2TBM	1/2" Tube Male	5
CPF			
	MPF-MPF	Female to Female	10
	MPF-MPFTU	T-Union (Female)	10
	MPF-MPFBULK	Bulkhead (Female to Female)	10
	MPF-CAP	Cap	10
ADDITIONAL			
	MPF-M20QTF	M20 x 1.5 Quick Test Female	5
	MPF-M20X1.5F	M20 x 1.5 Female	10
	MPF-QCN	Quick-Connect Nut	5
	MPF-AN4M	AN4 Male	5

### ► Non-CPF MP Fittings

Medium Pressure FEMALE to NPT FEMALE			
	4501	1/8 NPT	15
	4715 *	1/4 NPT	15
	4502	3/8 NPT	15
	4503	1/2 NPT	15
Medium Pressure FEMALE to NPT MALE			
	4714	1/4 NPT	15
	4494	3/8 NPT	15
	4495	1/2 NPT	15
	4496	3/4 NPT	10
Medium Pressure MALE to NPT FEMALE			
	4497	1/8 NPT	15
	4498	1/4 NPT	15
	4499	3/8 NPT	15
	4500	1/2 NPT	15
Medium Pressure MALE to NPT MALE			
	4698	1/4 NPT	15
	4492	3/8 NPT	15
	4493	1/2 NPT	15

- 5 300 bar/5000 psi
- 10 700 bar/10000 psi
- 15 1000 bar/15000 psi  
(Non-CPF MP adapters require wrench tightening.)

\* These parts are included with the T-1-CPF pump. Additional parts are supplied as part of a pump system, or may be ordered separately. All BSP connections require bonded seals.

# Specifications

## Pressure Ranges

T, T-1, T-1-CPF, T-2, and T-3 ..... 0 to 1000 bar / 0 to 15 000 psi

## Recommended Test Fluids

The following fluids are recommended for use with this pump:

Standard ..... Distilled water or Isopropyl alcohol

Optional ..... MGAAA oil

Other fluids compatible with stainless steel, Monel, Buna N and Teflon may be used. Optional Viton and EPT o-rings are available.

Volume ..... 30 oz (887 mL)

Low Volume / High Pressure Setting ... 2.8 to 3.2 cc per stroke

High Volume / Low Pressure Setting ... 3.0 to 4.0 cc per stroke

## Pressure Connections

### ► Reference Port

T-1, T-2, and T-3 ..... 1/4" FNPT or 1/2" FNPT

T-1-CPF ..... CPF Male

### ► Device Under Test Port

T-1, T-2, and T-3 ..... 1/4" FNPT or 1/2" FNPT

T-1-CPF ..... 1/4" Female NPT

**Note:** Additional sizes, including metric fittings, are available. Contact us, or see our [CPF datasheet](#) for details.

## Dimensions

Pump ..... 224 (L) x 127 (W) x 217 (H)\* mm.

Weight ..... 18.6 lbs / 8.4 kg

\* Height includes manifold.



# Support

## TROUBLESHOOTING

### Failure to Pump

- ▶ **Problem:** The pump fails to develop pressure when the hand lever is operated.
- ▶ **Solution:** Verify that the vent valve is closed and that there is sufficient fluid in the reservoir. If necessary, add fluid through the fill plug and follow the Pump Priming Procedure.

If the failure continues, one or both of the check valves may be leaking. Use the following procedure to replace both the high pressure and low pressure o-rings.

#### ▶ To Replace the Check Valve O-rings

- 1 Raise the pump handle to the top of its stroke.
- 2 Position the valve rod selector for the o-ring you wish to replace.
  - (a) Pull out the valve rod selector to select the low pressure/high volume setting.
  - (b) Push in the valve rod selector to select the high pressure/low volume setting.
- 3 Remove the plug and o-ring from the port for the check valve o-ring you wish to replace.

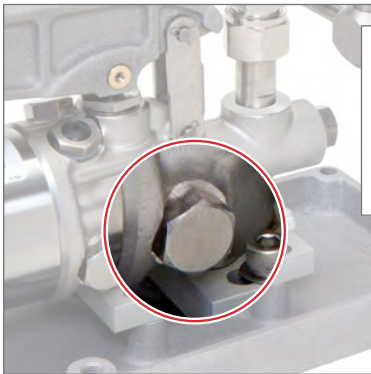

Low pressure/high volume check valve plug and o-ring.

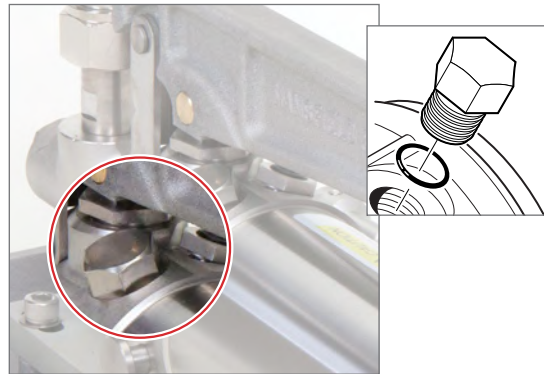

High pressure/low volume check valve plug and o-ring.

- 4** Remove the check valve spacer, spring, valve poppet, and check valve o-ring.

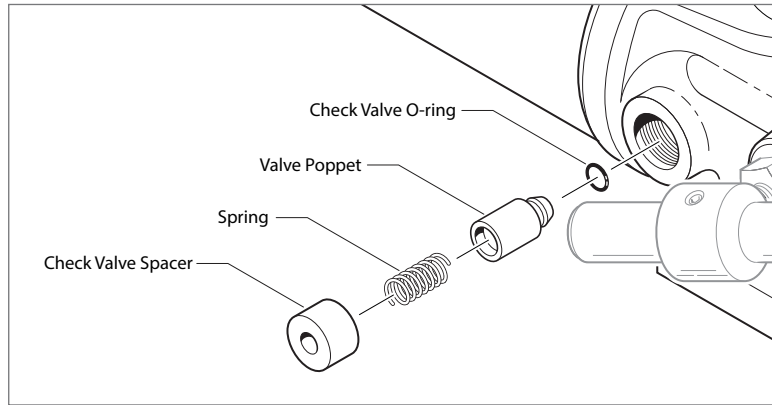

- 5** Inspect the check valve o-ring, and replace it if necessary. Then re-install the o-ring, valve poppet, spring, and check valve spacer.

- 6** Slowly pump two and one-half strokes, positioning the pump lever at approximately 45 degrees, halfway through its stroke.

- 7** Allow system fluid to flow out of the low pressure check valve, flushing entrapped air.

- 8** Examine the port for air bubbles which may adhere to the threads or parts.

**Note:** If air bubbles are present, repeat steps 2 through 5 until no more air bubbles appear.

- 9** Install the check valve plug and o-ring and tighten partially.

- 10** **If installing the low pressure/high volume check valve plug...** Tighten the check valve plug.

The procedure for the low-pressure/high volume side is now complete.

- 11** **If installing the high pressure/low volume check valve plug...** Use slight pressure on the hand lever to push system fluid past the high pressure/low volume check valve plug to ensure complete purging of the valve port.

- 12** Tighten the high pressure/low volume check valve plug.

- 13** Operate the pump handle until pumping becomes difficult.

- 14** Raise the pump handle to the top of its stroke.

- 15** Push in the valve rod selector to the high pressure/low volume position.

- 16** Resume pumping to verify the pump is operating properly.

## Pump Does Not Hold Pressure

- ▶ **Problem:** The pump operates but the pressure declines beyond normal adiabatic effects.
- ▶ **Solution:** One of two o-rings may be leaking. As the pressure drops, observe the hand lever. If the hand lever rises, the discharge check valve is leaking and its o-ring should be replaced.
- ▶ **To Replace the Discharge Check Valve O-ring**

**1** Remove the plug and o-Ring from the front of the pump body.

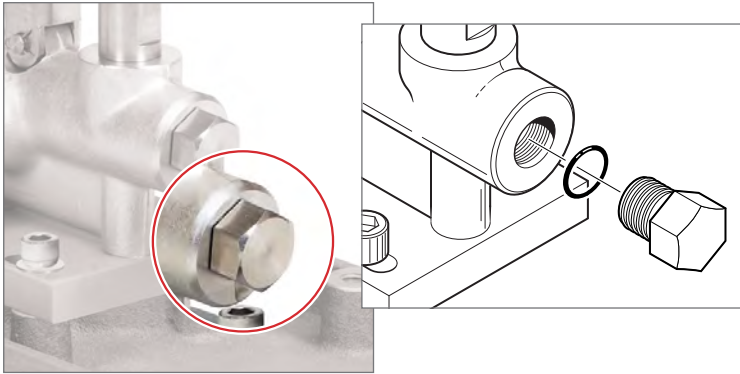

**2** Use a screwdriver to loosen and remove the retaining plug. then remove the guide rod, spring, valve poppet and check valve o-ring.

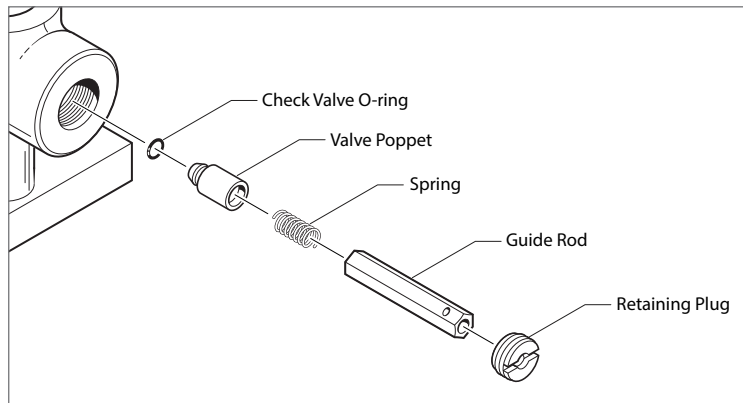

- 3** Inspect the check valve o-ring, and replace it if necessary. Then re-install the o-ring, valve poppet, spring, and guide rod.
- 4** Thread in the retaining plug until it is tightly seated. Then back off 3 ½ turns to provide sufficient travel for the valve poppet.
- 5** Install the check valve plug and o-ring.

► **To Replace the Vent Valve O-ring**

- 1 Apply a wrench to the nut at the base of the pressure relief valve.
- 2 Remove the vent valve and its o-ring.

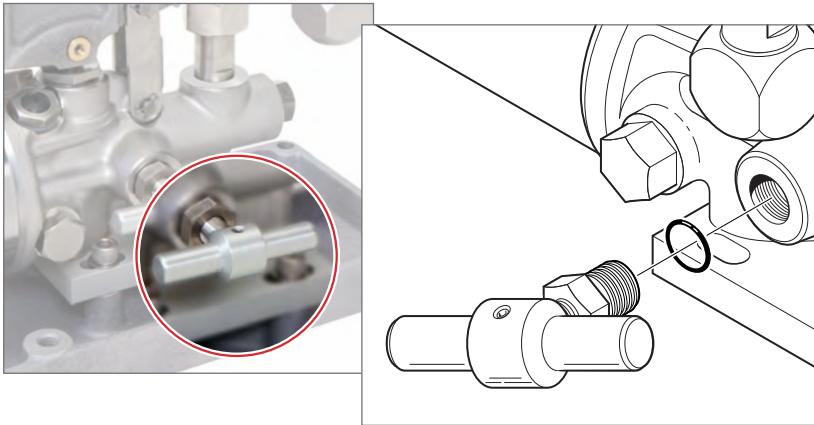

- 3 Remove the relief valve seat and its o-ring.

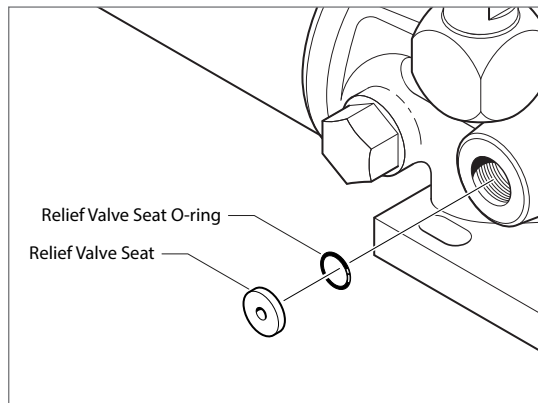

- 4 Inspect the relief valve seat o-ring, and replace it if necessary. Then re-install the o-ring, valve poppet, spring, and guide rod.
- 5 Install the vent valve and o-ring.

## FITTING KITS AND SPARE PARTS

---

### Service Kits

#### ► T, T-1, T-2, and T-3

**T-250**..... Buna N rebuild kit

**T-559**..... Viton rebuild kit

**T-326**..... EPT rebuild kit

#### ► T-1-CPF

**T-559**..... Viton rebuild kit

### Hoses

#### ► T-1

**KH-18** .....Hose. 0.46 m 1/4" NPT male x 1/4" NPT male 700 bar / 10 000 psi.

#### ► T-1-CPF

**MPH-1**..... 1 meter CPF hose. 700 bar / 10 000 psi.

### Adapters

#### ► T-1, T-2, and T-3

**T-134**.....Union Body. 15/16-20 UNEF male x 1/4" NPT female.

**T-135**.....Union Body. 15/16-20 UNEF male x 1/2" NPT female.

**T-186**.....Union Body. 15/16-20 UNEF male x 7/16" NPT female.

**T-331**.....Union Body. 15/16-20 UNEF male x 3/8" NPT female.

**T-863**.....Union Body. 15/16-20 UNEF male x 1/8" NPT female.

**T-786**.....Adapter. 1/4" NPT male x 1/4" BSP female.

**T-787**.....Adapter. 1/4" NPT male x 1/2" BSP female.

**T-915**.....Quick Connector. 1/4" NPT male.

**T-916**.....Quick Connector Plug. 1/4" NPT male.

#### ► T-1-CPF

Refer to the [Connection Diagram on page 13](#) for a complete list of adapters.

## Frequency of Recertification

Four test gauges are included with each T-3 Comparator. Gauges rated up to 5000 psi / 350 bar / 21 000 kPa / 210 kg/cm<sup>2</sup> are 0.25% of full scale. Gauges rated at 10 000 psi / 700 bar / 35 000 kPa / 350 kg/cm<sup>2</sup> are 0.5% of full scale. All of the gauges can be ordered with or without calibration certificates. For detailed information on the gauges refer to [Figure 4 on page 27](#).

As a general rule, AMETEK, M&G test gauges should be tested and recertified every 12 months. Testers used frequently, or with dirty fluids, should be tested and certified at more frequent intervals. Master units, used infrequently with clean fluid, may need to be tested and certified less frequently.

**Note:** It is not necessary to send in the pump if it is operating properly. Pumps may be refurbished at a nominal charge.

**Note:** In order to reduce process time and your overall cost, please do not send in any customized fittings, hoses, tools, or small miscellaneous parts.

## Certification Options for New and Used Comparators

Before ordering a new T-3 comparator or sending an old comparator back to M&G, specify one of the following certification options and any additional requirements on your purchase order. Contact your distributor if you need any assistance.

Option	Description	Details
A	Standard certification of accuracy traceable to NIST standards.	Item is repaired and calibrated. No data is provided.

### Options with Additional Cost

B	"With Data"— Option A Plus Data.	Item is repaired and calibrated. Data is provided.
C	"As Received/As Left"— Data plus Option A.	Item is cleaned and tested with no adjustments or repairs. Then the item is adjusted or repaired and recalibrated if necessary.

**APPENDIX A: ASSEMBLY DRAWINGS AND PARTS LISTS**

► Figure 1.1 • Hydraulic Hand Pump Type T Assembly

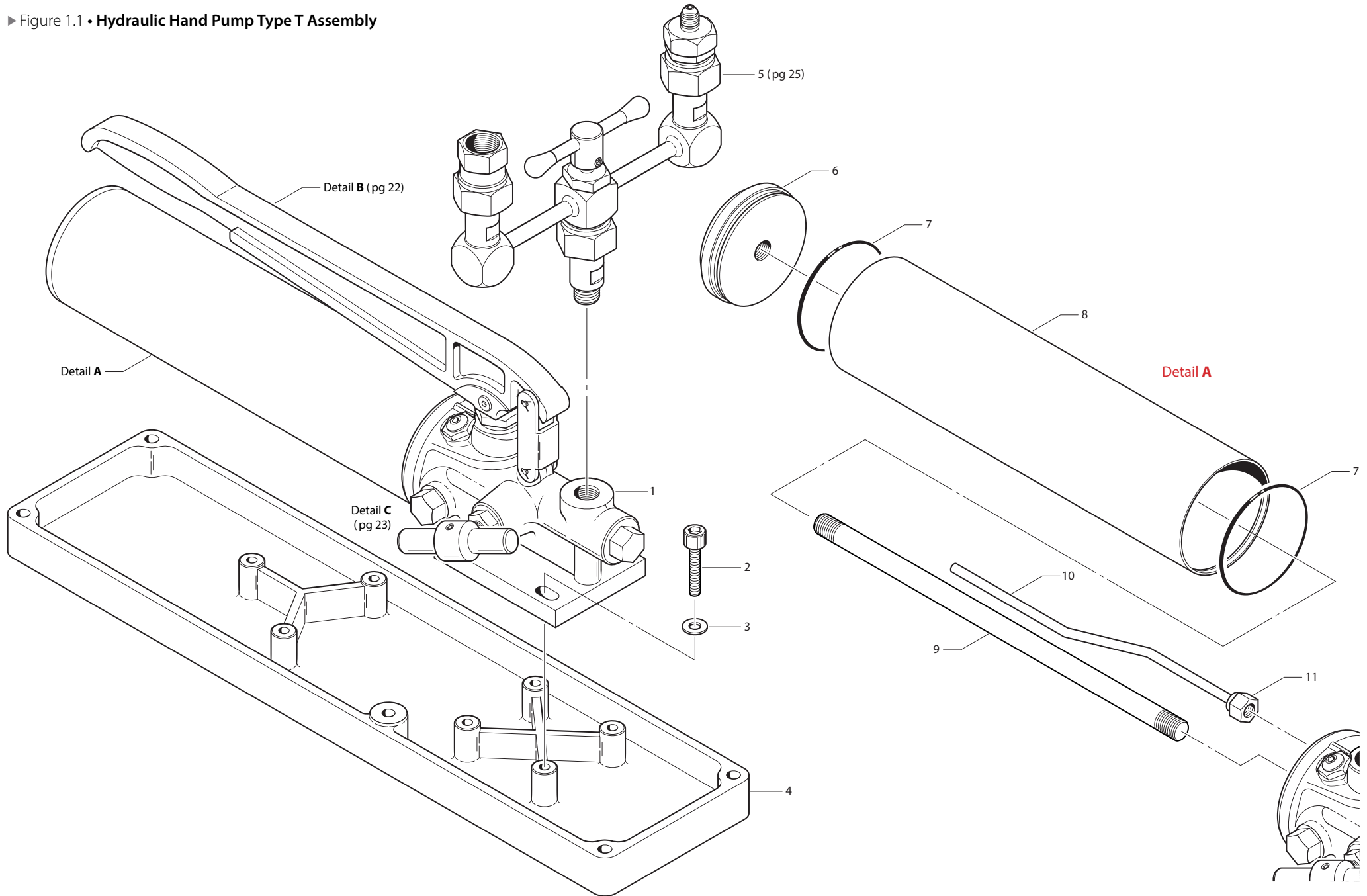

► Figure 1.2 • Hydraulic Hand Pump Type T Assembly

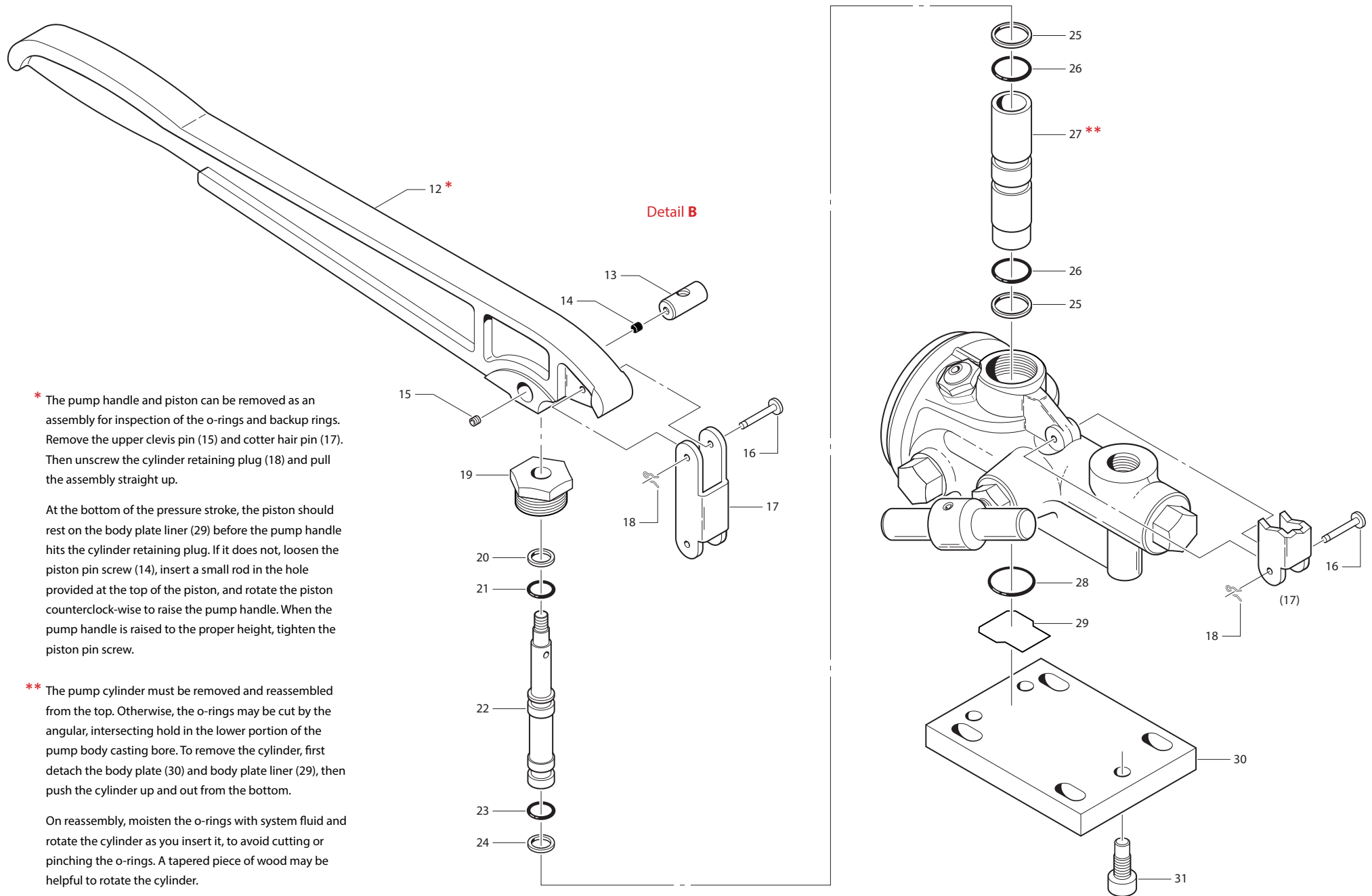



► Figure 1.3 • Hydraulic Hand Pump Type T Assembly

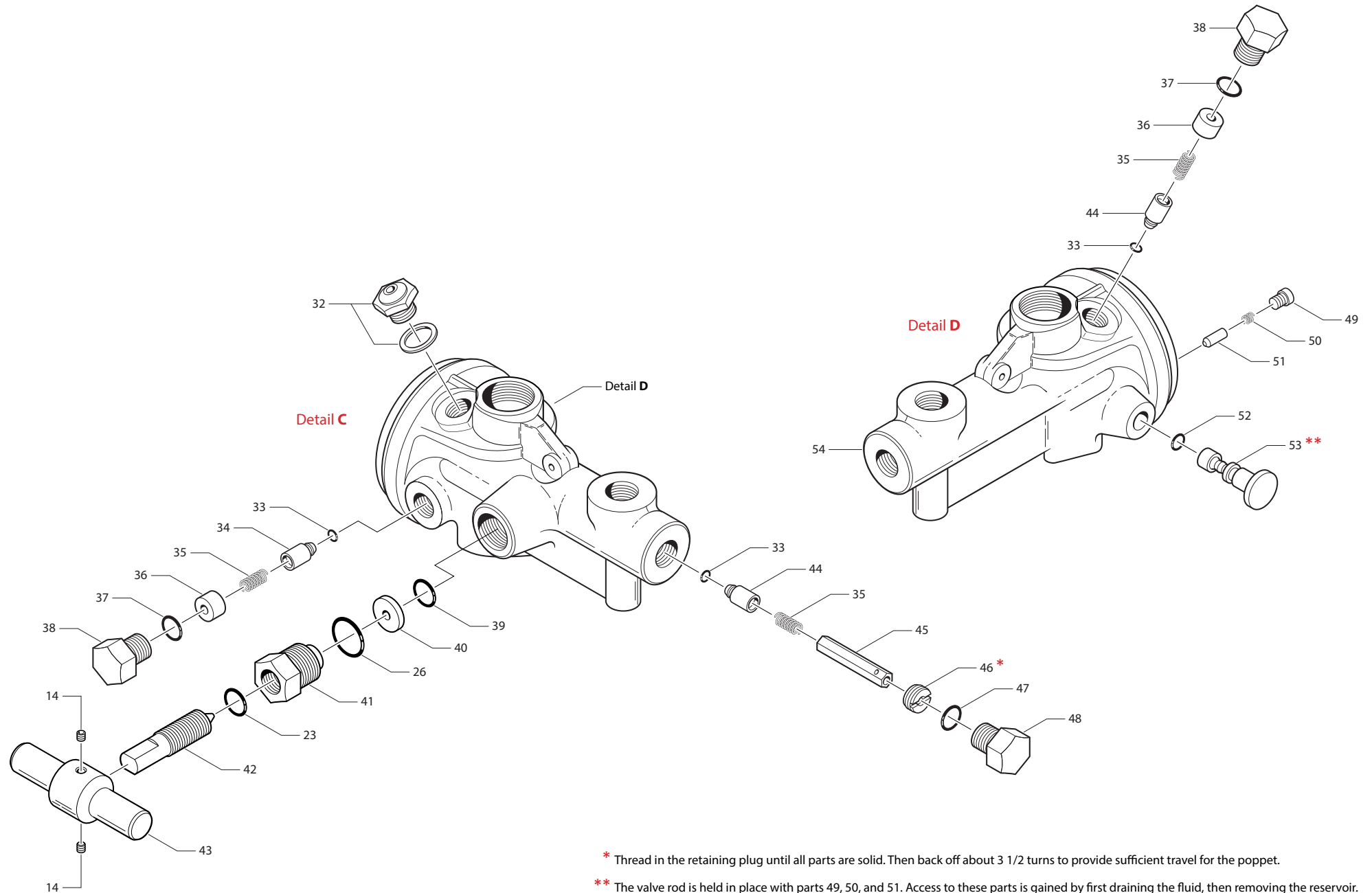

\* Thread in the retaining plug until all parts are solid. Then back off about 3 1/2 turns to provide sufficient travel for the poppet.

\*\* The valve rod is held in place with parts 49, 50, and 51. Access to these parts is gained by first draining the fluid, then removing the reservoir.

► Figure 1.4 • Hydraulic Hand Pump Type T Assembly Parts List

Item Number	Part Number	Description	Units Per Assembly
1	–	Type T Pump Assy	1
2	01-90007	Screw, Drip Pan Attaching	4
3	T-167	Washer, Drip Pan Attaching	4
4	T-118	Drip Pan	1
5	T-149	Manifold Assembly (see page 32)	1
6	T-328	Cap, Reservoir	1
7	10-90010	O-ring, Reservoir Tube (T-156)	2
8	T-131	Tube, Reservoir	1
9	T-130	Stud, Reservoir	1
10	T-140	Tube, Inlet	1
11	12-90152	Fitting, Inlet Tube	1
12	T-165	Handle, Pump	1
13	T-145	Pin, Piston	1
14	T-161	Shoe, Piston Pin	1
15	T-160	Screw, Piston Pin	3
16	T-142	Pin, Clevis	2
17	T-143	Clevis	1
18	T-144	Hair Pin, Cotter	2
19	T-108	Plug, Cylinder Retaining	1
20	10-90019	Back-up Ring, Piston (T-158)	1
21	10-90006	O-ring (T-154)	1
22	T-106	Piston	1
23	10-90005	O-ring (T-151)	2
24	10-90018	Back-up Ring, Piston (T-159)	1
25	10-90020	Back-up Ring, Cylinder (T-112)	2
26	10-90013	O-ring (T-153)	3
27	T-236	Cylinder, Pump	1
28	10-90012	O-ring, Cylinder (T-164)	1
29	T-595	Liner, Body Plate	1
30	T-408	Plate, Body	1
31	01-90004	Screw, Body Attaching	3
32	IGT-302	Plug and Spacer, Fill and Vent Relief Assy	1

Item Number	Part Number	Description	Units Per Assembly
33	10-90001	O-ring (T-152)	3
34	T-194	Poppet, Valve	1
35	CV-1-5	Spring, Check Valve	3
36	T-127	Spacer, Check Valve	2
37	10-90027	O-ring (T-154)	2
38	T-117	Plug, Pump Body	2
39	10-90002	O-ring (T-175)	1
40	T-111	Seat, Relief Valve	1
41	T-109	Body, Relief Valve	1
42	10-110	Stem, Relief Valve	1
43	T-773	Handle, Relief Valve	1
44	T-147	Poppet, High Pressure Valve	2
45	T-107	Guide Rod	1
46	T-141	Plug, Retaining	1
47	10-90009	O-ring (T-136)	1
48	T-103	Plug	1
49	T-166	Screw	1
50	T-116	Spring, Valve Rod	1
51	T-133	Detent Pin, Valve Rod	1
52	10-90004	O-ring	1
53	T-115	Valve Rod	1
54	T-120	Body, Pump	1

► Figure 2 • Manifold Assembly and Parts List

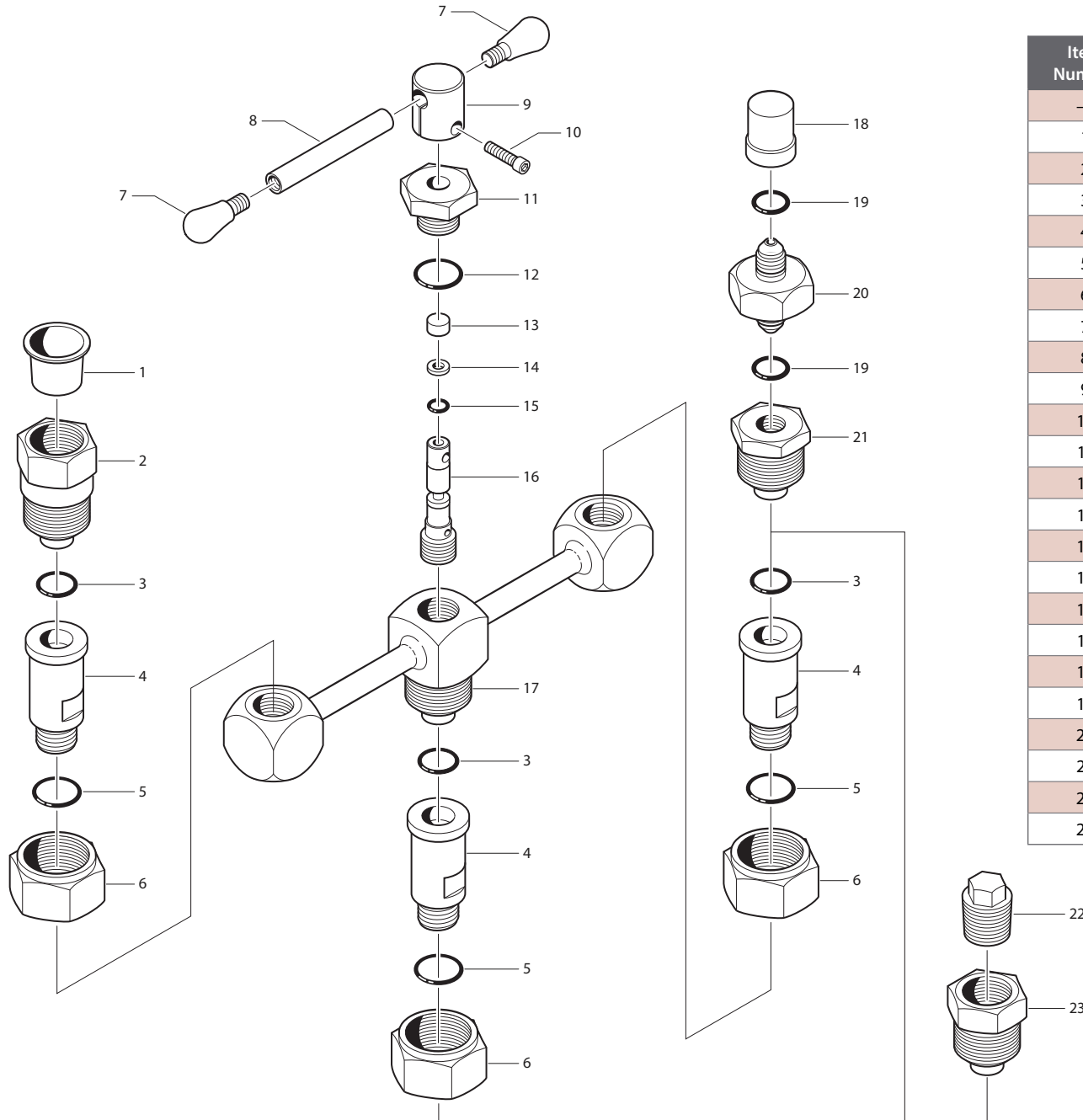

Item Number	Part Number	Description	Units Per Assembly
—	T-149	Type T Manifold Assembly	—
1	—	Thread Protector, ½ NPT	1
2	T-135	Body, Union — ½ NPT	1
3	10-90027	O-ring (T-154)	3
4	T-126	Nipple, Union	3
5	10-90009	O-ring, Union Nipple (T-136)	3
6	T-146	Nut, Union	3
7	T-102	Knob, Handle	2
8	T-119	Handle, Fine Adjust	1
9	T-132	Handle Hub, Fine Adjust	1
10	T-174	Screw, Hub	1
11	T-113	Bushing, Fine Adjust Piston	1
12	10-90011	O-ring, Fine Adjust (T-157)	1
13	T-190	Plug, Friction	1
14	10-90017	Back-up Ring, Fine Adjust (T-179)	1
15	10-90001	O-ring, Fine Adjust (T-152)	1
16	T-114	Piston, Fine Adjust	1
17	T-125	Manifold, Offset Pipe	1
18	99-90001	Cap	1
19	10-90005	O-ring, Nipple (T-151)	2
20	T-185	Nipple, 7/16–20 UNF	1
21	T-186	Body, Union — 7/16–20 UNF	1
22	T-162	Plug, Pipe	1
23	T-134	Body, Union — ¼ NPT	1

► Figure 3 • Service Tools and Parts List

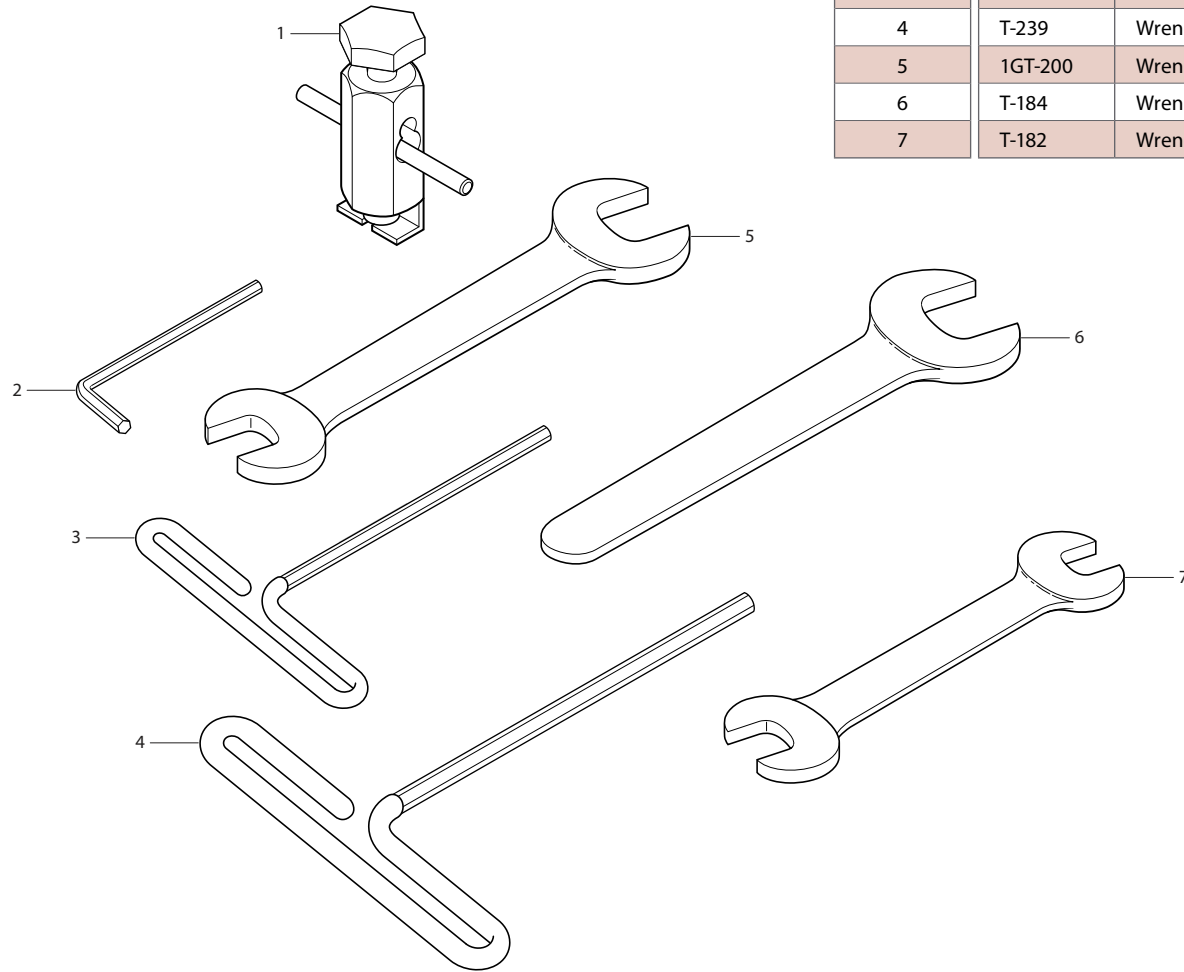

Item Number	Part Number	Description	Units Per Assembly
1	1GT-99	Puller and Set Assembly, Gauge Pointer	1
2	T-180	Wrench, $\frac{5}{32}$ " Hexagon Key, Short Series	1
3	T-204	Wrench, $\frac{3}{16}$ " Hexagon Key, Tee Handle	1
4	T-239	Wrench, $\frac{1}{4}$ " Hexagon Key, Tee Handle	1
5	1GT-200	Wrench, Open End, Thin 1"	1
6	T-184	Wrench, Open End, Thin 1 $\frac{5}{8}$ "	1
7	T-182	Wrench, Open End, Thin $\frac{5}{8}$ " x $\frac{3}{4}$ "	1

► Figure 4 • Gauge and Fitting Assembly and Parts List

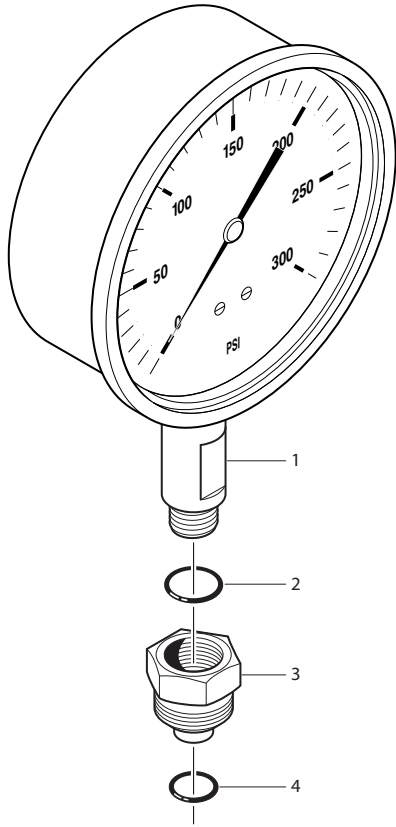

Item Number	Part Number	Description	Units Per Assembly
1	—	Gauge and Fitting Assembly	4
	T-274	Test Gauge, 4 ½", 0-30 psi	*
	T-275	Test Gauge, 4 ½", 0-160 psi	*
	T-276	Test Gauge, 4 ½", 0-600 psi	*
	T-277	Test Gauge, 4 ½", 0-3000 psi	*
	T-278	Test Gauge, 4 ½", 0-5000 psi	*
	T-279	Test Gauge, 4 ½", 0-10 000 psi	*
	T-590	Test Gauge, 4 ½", 0 - 2 kg/cm <sup>2</sup>	*
	T-591	Test Gauge, 4 ½", 0 - 42 kg/cm <sup>2</sup>	*
	T-592	Test Gauge, 4 ½", 0 - 210 kg/cm <sup>2</sup>	*
	T-593	Test Gauge, 4 ½", 0 - 350 kg/cm <sup>2</sup>	*
	T-596	Test Gauge, 4 ½", 0 - 200 kPa	*
	T-597	Test Gauge, 4 ½", 0 - 4000 kPa	*
	T-598	Test Gauge, 4 ½", 0 - 21 000 kPa	*
	T-599	Test Gauge, 4 ½", 0 - 35 000 kPa	*
	T-604	Test Gauge, 4 ½", 0 - 11 bar	*
	T-605	Test Gauge, 4 ½", 0 - 42 bar	*
	T-606	Test Gauge, 4 ½", 0 - 350 bar	*
	T-607	Test Gauge, 4 ½", 0 - 700 bar	*
2	10-90009	O-ring, Body Union (T-136)	**
3	T-173	Body, Union	**
4	10-90027	O-ring, Body Union	**

\* Gauges will be provided based on the Comparator Testing Kit selected.

\*\* One each per Gauge Assembly.

## CONTACT US

---

### United Kingdom

Tel +44 (0)1243 833 302

[jofra@ametek.co.uk](mailto:jofra@ametek.co.uk)

### France

Tel +33 (0)1 30 68 89 40

[general.lloyd-instruments@ametek.fr](mailto:general.lloyd-instruments@ametek.fr)

### Germany

Tel +49 (0)2159 9136 510

[info.mct-de@ametek.de](mailto:info.mct-de@ametek.de)

### Denmark

Tel +45 4816 8000

[jofra@ametek.com](mailto:jofra@ametek.com)

### USA

*Florida - Mansfield & Green*

Tel +1 (800) 527 9999

[cal.info@ametek.com](mailto:cal.info@ametek.com)

*California - Crystal Engineering*

Tel +1 (800) 444 1850

[crystal@ametek.com](mailto:crystal@ametek.com)

### India

Tel +91 22 2836 4750

[jofra@ametek.com](mailto:jofra@ametek.com)

### Singapore

Tel +65 6484 2388

[jofra@ametek.com](mailto:jofra@ametek.com)

### China

*Shanghai*

Tel +86 21 5868 5111

*Beijing*

Tel +86 10 8526 2111

*Guangzhou*

Tel +86 20 8363 4768

[jofra.sales@ametek.com.cn](mailto:jofra.sales@ametek.com.cn)

## RETURNING PRODUCT TO AMETEK

---

Please contact your sales representative to complete a Return Material Authorization (RMA) form and/or receive an RMA number.

Return/shipping instructions will be provided with the RMA number.

## WARRANTY

---

This instrument is warranted against defects in workmanship, material and design for one (1) year from date of delivery to the extent that AMETEK will, at its sole option, repair or replace the instrument or any part thereof which is defective, provided, however, that this warranty shall not apply to instruments subjected to tampering or, abuse, or exposed to highly corrosive conditions.

THIS WARRANTY IS IN LIEU OF ALL OTHER WARRANTIES WHETHER EXPRESS OR IMPLIED AND AMETEK HEREBY DISCLAIMS ALL OTHER WARRANTIES, INCLUDING, WITHOUT LIMITATION, ANY WARRANTY OF FITNESS FOR A PARTICULAR PURPOSE OR MERCHANTABILITY. AMETEK SHALL NOT BE LIABLE FOR ANY INCIDENTAL OR CONSEQUENTIAL DAMAGES, INCLUDING, BUT NOT LIMITED TO, ANY ANTICIPATED OR LOST PROFITS.

This warranty is voidable if the purchaser fails to follow any and all instructions, warnings or cautions in the instrument's Instruction Manual.

If a manufacturing defect is found, AMETEK will replace or repair the instrument or replace any defective part thereof without charge; however, AMETEK's obligation hereunder does not include the cost of transportation, which must be borne by the customer. AMETEK assumes no responsibility for damage in transit, and any claims for such damage should be presented to the carrier by the purchaser.



---

© 2018 AMETEK Incorporated  
8600 Somerset Drive, Largo, Florida 33773