

Net Safety™ Millennium

Air Particle Monitor (APM) Oil Mist Detector



Important instructions

Because these products are sophisticated technical instruments, it is important that the owner and operation personnel must strictly adhere both to the information printed on the product nameplate and to all instructions provided in this manual prior to installation, operation, and maintenance.

WARNING!

Installing, operating, or maintaining this product improperly could lead to serious injury or death from explosion or exposure to dangerous substances. Comply with all information on the product, in this manual, and in any local and national codes that apply to the product. Do not allow untrained personnel to work with this product.

The information in this document has been carefully checked and is believed to be entirely reliable with all of the necessary information included.

WARNING!

All individuals who have or will have responsibility for using, maintaining, or servicing the product must read this manual carefully.

CAUTION!

EQUIPMENT DAMAGE

The detector is not field repairable due to the meticulous alignment and calibration of the sensors and the respective circuits.

Warranty

- Limited Warranty** . Subject to the limitations contained in Section 2 (Limitation of Remedy and Liability) herein, Seller warrants that (a) the licensed firmware embodied in the Goods will execute the programming instructions provided by Seller; (b) that the Goods manufactured by Seller will be free from defects in materials or workmanship under normal use and care; and (c) Services will be performed by trained personnel using proper equipment and instrumentation for the particular Service provided. The foregoing warranties will apply until the expiration of the applicable warranty period. Sensors and detectors are warranted against defective parts and workmanship for 24 months from the date of purchase and other electronic assemblies for 36 months from the date of purchase. Products purchased by Seller from a third party for resale to Buyer (Resale Products) shall carry only the warranty extended by the original manufacturer. Buyer agrees that Seller has no liability for Resale Products beyond making a reasonable commercial effort to arrange for procurement and shipping of the Resale Products. If Buyer discovers any warranty defects and notifies Seller thereof in writing during the applicable warranty period, Seller shall, at its option, (i) correct any errors that are found by Seller in the firmware or Services; (ii) repair or replace FOB point of manufacture that portion of the Goods found by Seller to be defective; or (iii) refund the purchase price of the defective portion of the Goods/Services. All replacements or repairs necessitated by inadequate maintenance; normal wear and usage; unsuitable power sources or environmental conditions; accident; misuse; improper installation; modification; repair; use of unauthorized replacement parts; storage or handling; or any other cause not the fault of Seller are not covered by this limited warranty and shall be replaced or repaired at Buyer's sole expense, and Seller shall not be obligated to pay any costs or charges incurred by Buyer or any other party except as may be agreed upon in writing in advance by Seller. All costs of dismantling, reinstallation, freight, and the time and expenses of Seller's personnel and representatives for site travel and diagnosis under this limited warranty clause shall be borne by Buyer unless accepted in writing by Seller. Goods repaired and parts replaced by Seller during the warranty period shall be in warranty for the remainder of the original warranty period or 90 days, whichever is longer. This limited warranty is the only warranty made by Seller and can be amended only in a writing signed by an authorized representative of Seller. The limited warranty herein ceases to be effective if Buyer fails to operate and use the Goods sold hereunder in a safe and reasonable manner and in accordance with any written instructions from the manufacturers. THE WARRANTIES AND REMEDIES SET FORTH ABOVE ARE EXCLUSIVE. THERE ARE NO REPRESENTATIONS OR WARRANTIES OF ANY KIND, EXPRESSED OR IMPLIED, AS TO MERCHANTABILITY, FITNESS FOR PARTICULAR PURPOSE, OR ANY OTHER MATTER WITH RESPECT TO ANY OF THE GOODS OR SERVICES.
- Limitation of Remedy and Liability** SELLER SHALL NOT BE LIABLE FOR DAMAGES CAUSED BY DELAY IN PERFORMANCE. THE REMEDIES OF BUYER SET FORTH IN THE AGREEMENT ARE EXCLUSIVE. IN NO EVENT, REGARDLESS OF THE FORM OF THE CLAIM OR CAUSE OF ACTION (WHETHER BASED IN CONTRACT, INFRINGEMENT, NEGLIGENCE, STRICT LIABILITY, OTHER TORT, OR OTHERWISE), SHALL SELLER'S LIABILITY TO BUYER AND/OR BUYER'S CUSTOMERS EXCEED THE PRICE TO BUYER OF THE SPECIFIC GOODS MANUFACTURED OR SERVICES PROVIDED BY SELLER GIVING RISE TO THE CLAIM OR CAUSE OF ACTION. BUYER AGREES THAT IN NO EVENT SHALL SELLER'S LIABILITY TO BUYER AND/OR BUYER'S CUSTOMERS EXTEND TO INCLUDE INCIDENTAL, CONSEQUENTIAL OR PUNITIVE DAMAGES. THE TERM "CONSEQUENTIAL DAMAGES" SHALL INCLUDE, BUT NOT BE LIMITED TO, LOSS OF ANTICIPATED PROFITS, REVENUE OR USE AND COSTS INCURRED, INCLUDING WITHOUT LIMITATION FOR CAPITAL, FUEL AND POWER, AND CLAIMS OF BUYER'S CUSTOMERS.

Contents

Chapter 1	Introduction	1
1.1	Models covered	1
1.2	Service support	1
1.3	Return of material	2
1.4	Product recycling/disposal	2
Chapter 2	Installation	3
2.1	Unpacking and inspection	3
2.2	Locate sensor	4
2.3	Dimensions	5
2.4	Mount	7
2.4.1	Duct mount	8
2.5	Wire	10
2.5.1	Field installation	10
2.5.2	Seals	10
2.5.3	Sensor separation	11
2.5.4	Board assembly	11
2.5.5	Installation to transmitter or junction box	12
2.5.6	Faceplate rotation	13
2.5.7	General requirements	14
2.5.8	Wiring sensor to transmitter	15
2.5.9	Wire sensor to junction box	17
2.5.10	Wiring transmitter to control system	18
2.5.11	External ground	18
2.6	Current output	18
2.7	Non-isolated and isolated power configurations	19
2.8	Installation checklist	21
Chapter 3	Operation	23
3.1	Net Safety™ Millennium Transmitter	23
3.1.1	Display	24
3.1.2	Status LED	24
3.1.3	On/Off switch	24
3.1.4	Setup button	24
3.1.5	Magnetic Reed switch	24
3.1.6	Current output check	24
3.2	Indications and outputs	25
3.3	Alarms	25
3.3.1	Net Safety APM fault	25
3.3.2	Clean window/dirty chamber	25
3.3.3	Particulate alarm	26
3.4	Reset	26
3.4.1	Remote reset	26
3.4.2	Manual reset	26
3.5	Normal	26
3.6	Outputs	26

	3.6.1	Relays	26
	3.6.2	Current	27
3.7		Net Safety APM Sensor	27
	3.7.1	Sensor power up	27
	3.7.2	Sensor communication	27
Chapter 4		Programming	29
	4.1	Main menu	29
	4.2	Accessing the main menu	29
	4.3	Using the main menu	29
	4.3.1	Zero	31
	4.3.2	Sensitivity settings	32
	4.3.3	Review relay settings	33
	4.3.4	Set relay options	33
	4.3.5	Select display language	35
Chapter 5		Maintenance	37
	5.1	Response check	37
	5.2	Cleaning	37
	5.3	Troubleshooting	38
	5.4	Storage	38
	5.5	Spare parts and accessories	38
Chapter 6		Electrostatic sensitive device	39
Chapter 7		Wire resistance table	41
Chapter 8		Specifications	43
Chapter 9		Certifications	45
	9.1	North American hazardous locations	45
	9.1.1	Transmitter	45
	9.1.2	APM Sensor	45
	9.1.3	Junction box (Model JB-MPD)	46
	9.2	ATEX (-X model)	46
	9.2.1	Transmitter	46
	9.2.2	APM Sensor	46
	9.2.3	Junction box (Model JB-MPD)	47
	9.3	IECEX (-X model)	47
	9.3.1	Transmitter (aluminum)	47
	9.3.2	Transmitter (stainless steel)	47
	9.3.3	APM Sensor	47
	9.3.4	Junction box (Model JB-MPD)	48
Chapter 10		Ordering information	49

1 Introduction

1.1 Models covered

The Net Safety™ Air Particle Monitor (APM) is an infrared optical detector used in hazardous industrial applications to monitor ambient air for the presence of particulate matter from products of combustion such as carbon, air particulate matter, or ash.

The Net Safety Millennium Transmitter is an environmentally protected electronic package contained within an explosion-proof housing. With its scrolling 8-character display and status LEDs, it provides instructions and status alerts.

The Net Safety APM Sensor is mounted where airborne particles are anticipated to accumulate, while the Net Safety Millennium Transmitter is located conveniently at eye level.

The product is available in aluminum and stainless steel (SS).

Models available are:

- MLP-AR-APM-OP: APM, 4-20 mA analog output with alarm and fault relays, aluminum housing, CSA approved
- MLP-AR-APM-OP-X: APM, 4-20 mA analog output with alarm and fault relays, aluminum housing, CSA, ATEX, and IECEx approved
- MLP-AR-APM-OP-SS: APM, 4-20 mA analog output with alarm and fault relays, stainless steel housing, CSA approved
- MLP-AR-APM-OP-SS-X: APM, 4-20 mA analog output with alarm and fault relays, stainless steel housing, CSA, ATEX, and IECEx approved

1.2 Service support

Technical support for this product can be provided by contacting your local Emerson/Net Safety representative or by contacting the Net Safety Technical Support department at: Toll Free + 866 347 3427 or Safety.CSC@emerson.com.

1.3 Return of material

To expedite the repair and return of this product, proper communication between the customer and the factory is important. Before returning a product for repair, call +1 403 219-0688 or e-mail Safety.CSC@emerson.com for a Material Return Authorization (MRA) number.

On the return of the equipment, include the following information:

1. MRA number provided to you by Net Safety
2. Company name and contact information
3. Purchase order, from your company, authorizing repairs or request for quote

Procedure

1. Ship all equipment, prepaid to:
Emerson Automation Solutions
158 Edinburgh Ave
Slough, United Kingdom SL 1 4UE
2. Mark all packages with *Return for Repair* and include MRA number

Pack items to protect them from damage and use anti-static bags or aluminum-backed cardboard as protection from electrostatic damage.

Important

All equipment must be shipped prepaid. Collect shipments will not be accepted.

1.4 Product recycling/disposal

Consider recycling equipment and packaging and dispose of them in accordance with local and national legislations/regulations.

2 Installation

2.1 Unpacking and inspection

Carefully remove all of the components from the packaging and verify them against the enclosed packing list. Inspect all components for any obvious damage such as broken or loose parts. If you find any components missing or damaged, notify your local Emerson™ representative or the factory immediately. [Figure 2-1](#) outlines the components supplied with the Net Safety APM.

Figure 2-1: Net Safety APM Components

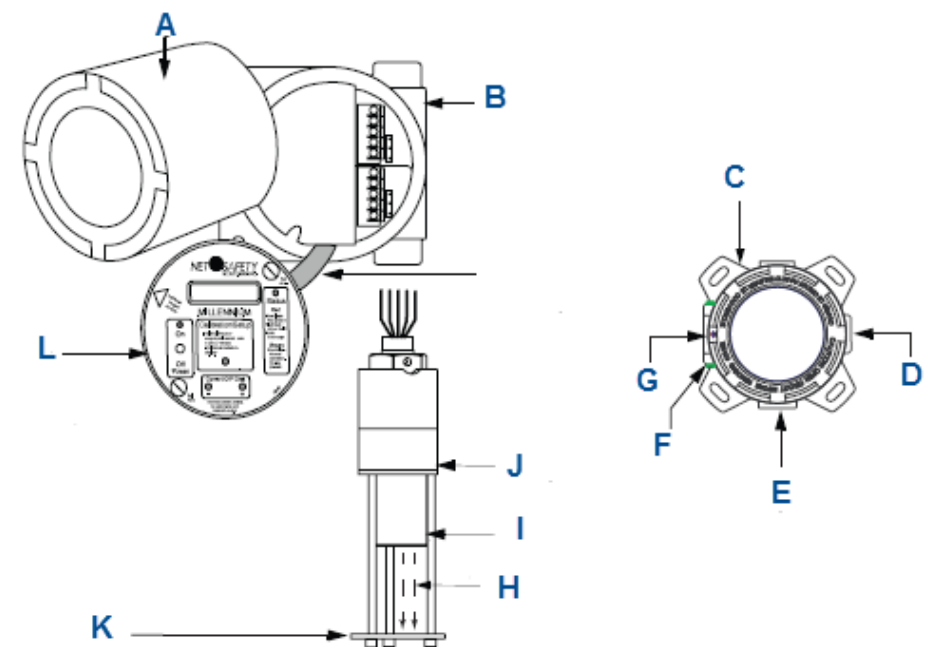

- A. Housing cover
- B. Millennium housing
- C. Junction box
- D. 3/4 in. NPT
- E. 3/4 in. NPT
- F. Earth ground screw
- G. 3/4 in. NPT
- H. Optical path
- I. Air particle monitor (APM)
- J. Internal window/sensor chamber
- K. Optical path protector plate. Uncrew to clean. Refer to [Section 5.2](#) for cleaning instructions.
- L. Millennium faceplate

2.2 Locate sensor

Prior to the installation process, develop a location plan for placing the Net Safety APM Sensor and Transmitter. Proper location of the Net Safety APM Sensor is essential for providing maximum protection. The most effective placement and number of detectors varies depending upon conditions. Consider the following points when planning the installation.

- Carefully locate the Net Safety APM Sensor in an area where particulate may potentially accumulate.
- Locate the Net Safety APM Sensor where it is safe from potential sources of contamination, such as oil film, dirt, etc.
- Locate the transmitter where it will be accessible and visible.
- Mount the Net Safety APM Sensor so air currents allow particulate to flow into the optical path of the sensor.
- If the particulate is expected to be moving horizontally due to air currents, orient the sensor for maximum detection as shown in [Figure 2-1](#).
- Avoid exposure to excessive heat or vibration whenever possible, because this can cause premature failure of electronic devices.
- Seek advice from experts and refer to various regulatory publications that discuss general guidelines for your industry.
- The Net Safety APM works off of the principle of infrared energy being reflected off of particulate matter passing through the optical path of the Net Safety APM. Therefore, give careful consideration when installing the Net Safety APM to ensure that external infrared light does not reach the sensing element.

[Figure 2-2](#) illustrates a typical installation of a Net Safety APM Sensor and Transmitter. The Net Safety APM Sensor is mounted separately from the transmitter using the supplied junction box. The transmitter is located at eye level, while the sensor is located where particles are most likely to accumulate. The conduit then connects the two devices.

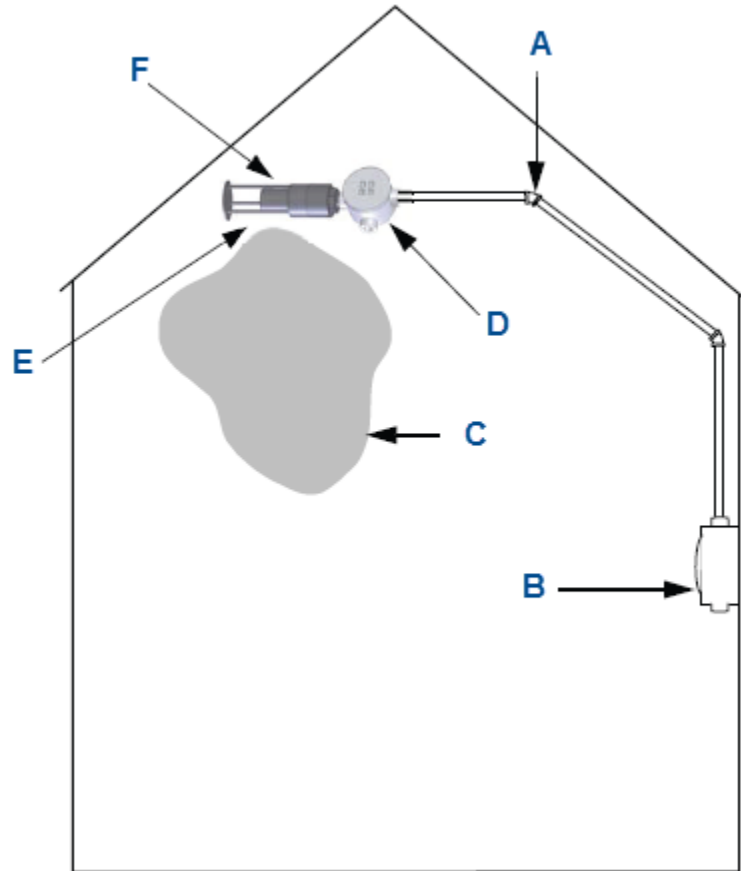
Figure 2-2: Typical Installation

- A. Conduit connecting junction box and controller
- B. Controller/transmitter mounted at eye level
- C. Particulate matter
- D. Junction box
- E. Net Safety APM Sensor positioned so air current allows particulate matter to flow into sensor
- F. Net Safety APM Sensor

2.3 Dimensions

The following figures outline the dimensions of the Net Safety APM connected directly to the Net Safety Millennium Transmitter ([Figure 2-3](#)) or when connected directly to the multi-purpose junction box ([Figure 2-4](#)). There are three (3) $\frac{3}{4}$ in. NPT conduit entries available on the Net Safety Millennium Transmitter. Adapters for M20 and $\frac{1}{2}$ in. NPT threads are also available as spare parts.

Figure 2-3: Transmitter Dimensions

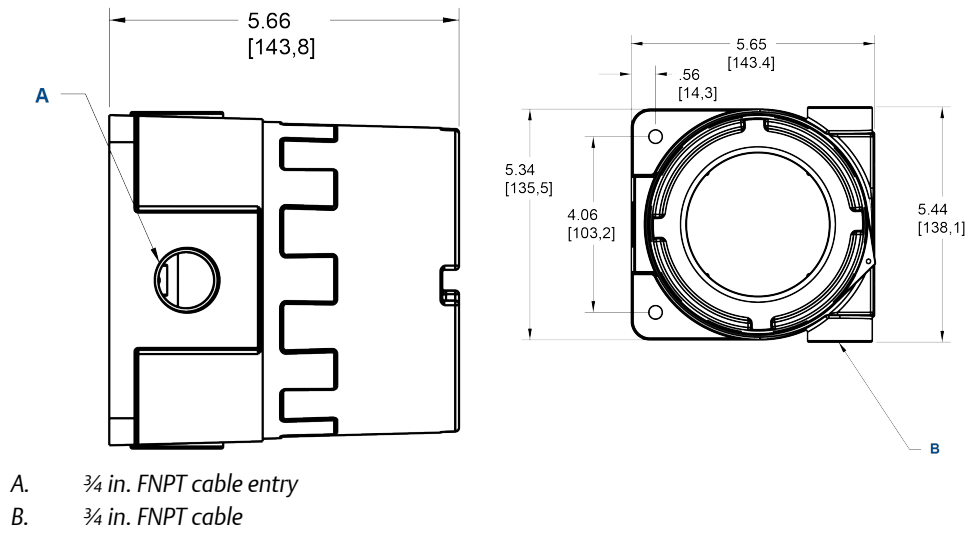
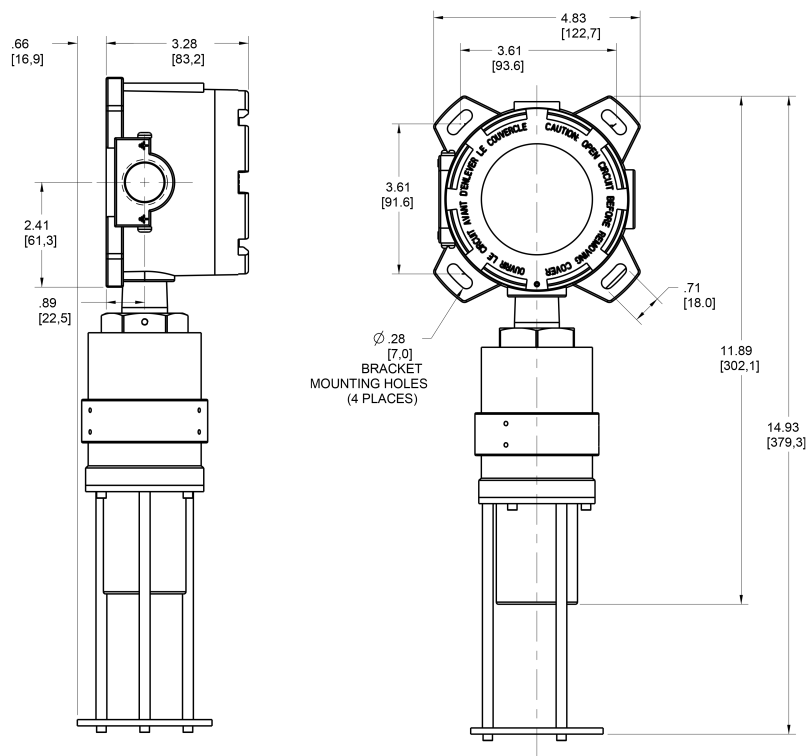

Figure 2-4: Junction Box and Sensor Dimensions



2.4 Mount

The sensor must be mounted directly to either a transmitter or to a separate junction box through a $\frac{3}{4}$ in. NPT conduit entry. Both the transmitter and junction boxes have mounting holes to allow mounting to a wall or pole as desired. Mounting kit hardware is required when mounting the transmitter or junction box to a pole. Contact your local Net Safety representative for detailed information on the pole mounting kits.

Mount the transmitter at eye-level and make it easily accessible for monitoring and maintenance purposes. Place the sensor where particles are likely to accumulate and across the direction of the airflow to allow the particulates to pass through the optical path. To prevent water damage, seal conduit at all points of entry to the transmitter or junction box.

Emerson™ recommends mounting the Net Safety APM Sensor such that the air flow will pass through the optical path of the sensor as shown in [Figure 2-5](#).

Note

The Net Safety APM works off of the principle of infrared energy being reflected off of particulate matter passing through the optical path of the Net Safety APM. Therefore, give careful consideration when installing the APM to ensure that external infrared light does not reach the sensing element.

The Net Safety APM may be affected by sudden bursts of infrared light; therefore, Emerson recommends putting a time delay (between two [2] and five [5] seconds) into the monitoring system to prevent nuisance alarms.

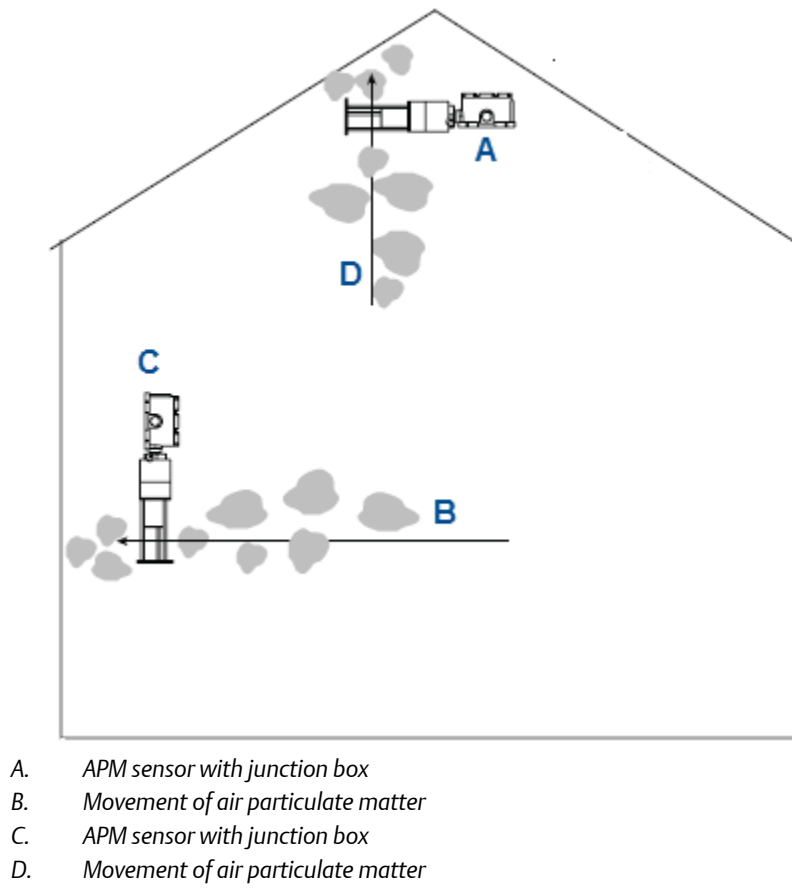
Figure 2-5: Net Safety APM Mounting Locations

2.4.1 Duct mount

Although the Net Safety Monitoring Air Particle Monitor has been proven to detect particulate matter travelling at speeds of up to 20 meters per second (65.62 feet per second), the detector is virtually unaffected by the velocity of particulate and air that it is exposed to. Based on the application and the speed of the particulate matter, you can perform a zero and adjust the sensitivity settings to suit the application.

Net Safety Monitoring recommends that the Net Safety APM be used with the UDM-001 or UDM-002 sample draw system to acquire a cross-sectional sample of air and particulate moving through ducts. The sample is drawn through perforations along the inlet pipe into a chamber where the Net Safety APM is mounted. Particulate matter from the outlet pipe is then returned to the duct. Refer to [Figure 2-6](#) and the [UDM-001/UDM-002 reference manual \(MAN-0116\)](#) for more information.

Figure 2-6: Air Flow Drawing

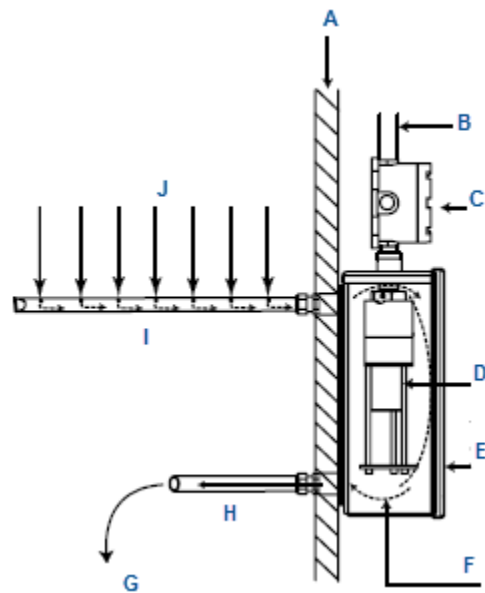

- A. Duct surface
- B. Conduit to controller
- C. Junction box
- D. APM sensor
- E. UDM-001/UDM-002 duct mount
- F. Broken lines indicate direction of air flow.
- G. Direction of outlet air sample
- H. Outlet pipe
- I. Perforated sample draw tube (inlet pipe)
- J. Direction of air sample flow

2.5 Wire

2.5.1 Field installation

⚠ WARNING!

ELECTRIC SHOCK

Failure to follow these installation guidelines could result in death or serious injury. Ensure that only qualified personnel perform the installation.

Electrical shock could cause death or serious injury. Use extreme caution when making contact with the leads and terminals.

Do not open the transmitter, sensor, or junction box enclosure when in a classified area or when an explosive atmosphere may be present unless the power to the transmitter has been removed.

Avoid touching electronic components as they are susceptible to electrostatic discharge (ESD). Refer to [Chapter 6](#) for more information.

Avoid contact with the non-metallic enclosure label as contact may create an electrostatic charging hazard.

NOTICE

Wiring codes and regulations may vary. ATEX requires that supply connections wiring must be rated at least 5 °C (41 °F) above the maximum ambient temperature of 85 °C (185 °F). Wiring must comply with all applicable regulations relating to the installation of electrical equipment in a hazardous area and is the installer's responsibility. If in doubt, consult a qualified official before wiring the system.

When separating the sensor from the transmitter, Emerson highly recommends the use of shielded cable to protect against interference caused by extraneous electrical or electromagnetic noise to meet mandatory CE mark electromagnetic compatibility (EMC) requirements. In applications where the wiring is installed in conduit, the conduit must not be used for wiring to other equipment.

2.5.2 Seals

Emerson recommends using seals to further protect the system against any unwanted water ingress and installing equipment according to applicable local electrical codes. Emerson especially recommends seals for installations that use high-pressure or steam cleaning devices in proximity to the transmitter and/or sensor.

- Emerson recommends water-proof and explosion-proof conduit seals to prevent water accumulation within the enclosure.
- Locate seals as close to the device as possible and not more than 18 inches (46 cm) away.
- Explosion-proof installations may require an additional seal where conduit enters a non-hazardous area. Ensure conformity with local wiring codes.

- When pouring a seal, use a fiber dam to assure proper formation of the seal. Never pour seals at temperatures below freezing.
- Strip back the jacket and shielding of the cable to permit the seal to form around the individual wires. This will prevent air, particles, and water leakage through the inside of the shield and into the enclosure.
- Emerson recommends using explosion-proof drains and conduit breathers. In some applications, alternate changes in temperature and barometric pressure can cause breathing which allows moist air to enter and circulate inside the conduit. Joints in the conduit system are seldom tight enough to prevent this breathing.

2.5.3 Sensor separation

Since the Net Safety APM Sensor must be located where it will pick up particulate in an air flow, and the transmitter where it can be easily reached, it is often necessary to separate the transmitter and sensor. This is done with the aid of the included sensor separation kit (SEP). This kit is composed of a junction box and terminal strip. Refer to the [Net Safety Multi-purpose Junction Box manual \(MAN-0081\)](#) for terminal designation.

The maximum separation distance between the sensor and the transmitter is limited by the resistance of the connecting wiring, which is a function of the gauge of wire being used. Net Safety recommends that sensor separation must not exceed 610 m (2,000 ft) while using 16 AWG (1.31 mm²) wire. Refer to [Chapter 7](#) for wire gauges and resistance values.

Note

When the sensor is separated from the transmitter, always ensure that the transmitter is supplying the required voltage to the sensor terminals inside the junction box. If the 4-20 mA signal is not used, connect a jumper between the 4-20 terminal and the COM terminal on the transmitter terminal board.

2.5.4 Board assembly

There are three different fixed boards and a relay board which make up the PCB assembly. Simply loosen the three locking standoffs, remove one board, insert the other board, and tighten screws. The boards are susceptible to electrostatic discharge (ESD). Refer to [Chapter 6](#) for further information on proper handling of this equipment.

Figure 2-7: Net Safety Millennium Transmitter Module Boards

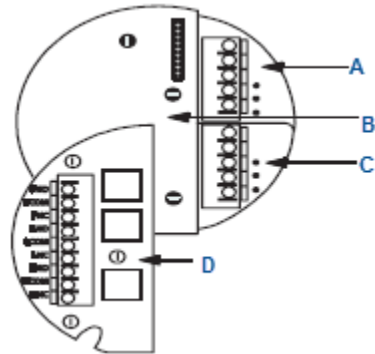

- A. Terminal board
- B. Option board
- C. Sensor board
- D. **Table 2-1: Electromechanical Relay Board**

PNO	Fault	Normally open
PCOM		Common
PNC		Normally closed
LNO	Clean window (low)	Normally open
LCOM		Common
LNC		Normally closed
HNO	Alarm	Normally open
HCOM		Common
HNC		Normally closed

2.5.5 Installation to transmitter or junction box

The Net Safety APM sensor is supplied with a ¾ in. NPT male conduit connection and is intended to be mounted directly to an available ¾ in. NPT conduit entry on the Net Safety Millennium Transmitter or remotely using the supplied junction box.

Tightly thread the sensor to the transmitter or junction box. A minimum of seven (7) threads need to be engaged to ensure proper water ingress protection and the explosion proof rating of the devices. Take proper care to ensure that no damage is caused to the wires on the Net Safety APM Sensor and circuit board inside the transmitter and junction box.

Emerson recommends using conductive grease on the threads.

The sensor can be mounted in a number of configurations to ensure that air particulate will pass through the optical path of the sensor. Emerson recommends that the APM be mounted horizontally to ensure that build-up of dirt, dust, and debris will not affect the operation of the sensor.

2.5.6 Faceplate rotation

In some applications, it is necessary for the Net Safety Millennium Transmitter to be mounted in a non-standard orientation. To accommodate such installations and ensure that the display will appear at the correct angle for viewing, you can rotate the PCB assembly inside the transmitter's housing. [Figure 2-8](#) outlines non-standard orientations of the Net Safety Millennium Transmitter.

Figure 2-8: Non-standard Orientation

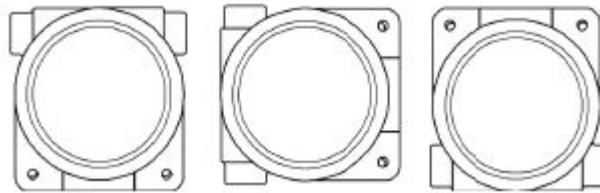

⚠ WARNING!

Do not open the transmitter, sensor, or junction box enclosure when in a classified area or when an explosive atmosphere may be present unless the power to the transmitter has been removed.

The following section describes the steps required to rotate the Net Safety Millennium Transmitter faceplate. Refer to [Figure 2-9](#) for the components in the transmitter housing. The boards may be susceptible to ESD. Refer to [Chapter 6](#) for further information on proper handling of this equipment.

Procedure

1. Remove the transmitter housing cover.
2. Turn the power to the transmitter off.
3. Unscrew both the knobs marked `Pull Here`.
4. Lift the transmitter faceplate from the housing and allow to the faceplate to hang from the ribbon cable.
5. Unscrew the two metal standoffs.
6. Carefully remove the PCB assembly from the housing.

The rotator plate is secured to the bottom of the housing and is accessible after the PCB assembly has been removed.

7. Rotate the PCB assembly to the desired position and line up the standoffs with the mounting holes.
8. Insert standoffs in the appropriate horizontal or vertical mounting holes.
9. Tighten standoffs to secure the PCB assembly.
10. Replace faceplate and tighten `Pull Here` knobs.
11. Return power to the detector and replace the housing cover.

Figure 2-9: PCB Assembly Rotated

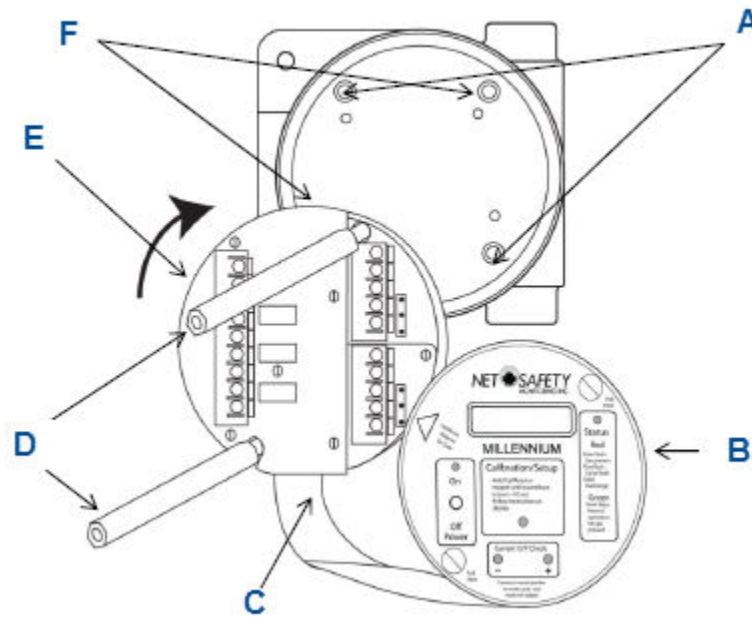

- A. Horizontal mounting holes
- B. Faceplate
- C. Ribbon cable
- D. Standoffs
- E. PCB assembly
- F. Vertical mounting holes

2.5.7 General requirements

⚠ WARNING!

EXPLOSION

Do not open the transmitter, sensor, or junction box enclosure when in a classified area or when an explosive atmosphere may be present unless the power to the transmitter has been removed.

When connecting cable wires, use a small screwdriver to gently press down and hold the spring connector open. Insert the appropriate wire into the open connector hole, releasing the screwdriver to secure the wire as shown in [Figure 2-10](#).

The connector accommodates wire sizes between 14 and 20 AWG.

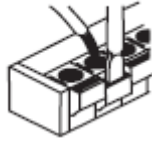
Figure 2-10: Terminal Connection

2.5.8 Wiring sensor to transmitter

Connect the sensor wires to the Net Safety Millennium Transmitter as shown in [Figure 2-11](#). [Table 2-2](#) outlines the wire colors and their purpose.

Table 2-2: Sensor Wire Colors and Terminal Definition

Wire color	White	Blue	Red	Black	Shield
Marking	+24 Vdc	Sig A	Sig B	COM(-)	Shld
Function	10.5-32 Vdc connection	Communication signal A	Communication signal B	Common / supply ground	Earth ground

Figure 2-11: Millennium sensor wiring

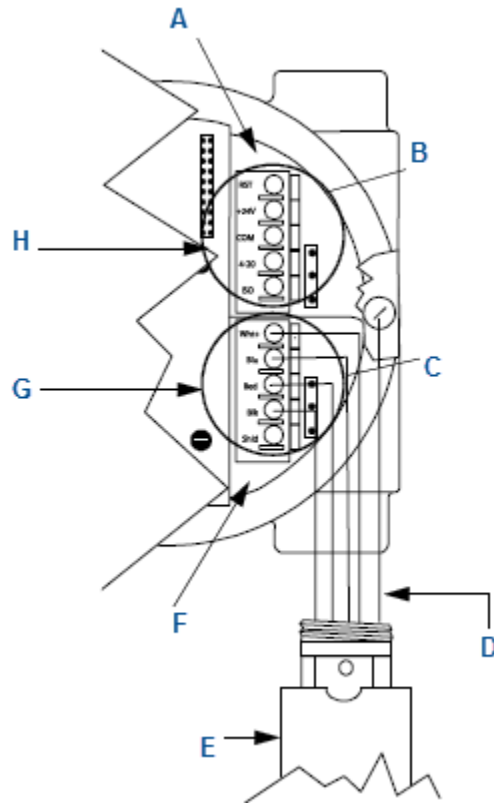

- A. Terminal board
- B. RST
+24 V
COM
4-20
ISO
- C. Wht
Blu
Red
Blk
Shld
- D. APM sensor wires
- E. APM sensor
- F. Sensor board
- G. Sensor terminals
- H. Power terminals

2.5.9 Wire sensor to junction box

Sensor wiring side refers to wiring between the sensor and junction box. Transmitter wiring side refers to wiring between the Net Safety Millennium (MLP) Transmitter and junction box.

Figure 2-12: Junction Box Wiring (Model JB-MPD)

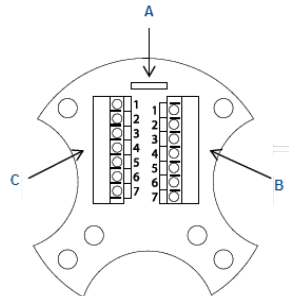

- A. Resistor - 120 ohms
 B. **Table 2-3: Transmitter Wiring**

Terminal	Function/markings
1 (GND)	Earth ground
2	Vdc (+)
3	COM (-)
4	Sig A
5	Sig B
6	Not used
7	Not used

- C. **Table 2-4: Sensor Wiring**

Terminal	Color	Function
1 (GND)	Green	Earth ground
2	White	Vdc (+)
3	Black	COM (-)
4	Blue	A (communication)
5	Red	B (communication)
6	N/A	Not used
7	N/A	Not used

Note

Shield should be terminated at earth ground at panel/PLC/DCS/RTU

2.5.10 Wiring transmitter to control system

Connect the Net Safety Millennium Transmitter to the control system as shown in [Figure 2-11](#). [Table 2-5](#) outlines the terminal marking and their purpose.

Table 2-5: Transmitter Connections

Marking	RST	+24V	COM	4-20	+VISO
Function	Remote reset	10.5-32 Vdc Connection	Common / supply ground	Current loop output (mA)	+24 Vdc isolated 4-20 power

2.5.11 External ground

In order to ensure proper operation of the sensor, an external earth ground is recommended. Net Safety recommends that the external ground be connected to the grounding point on the enclosure. Refer to [Figure 2-13](#) for grounding connection location.

Figure 2-13: External grounding point

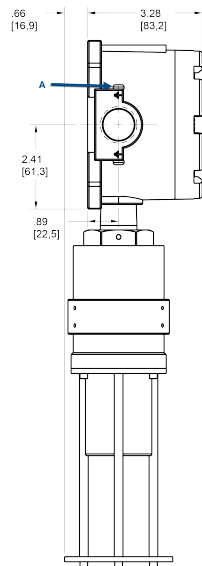

A. External grounding

2.6 Current output

To set the current output, simply move the jumper located on the terminal board near the power terminals, to the isolated or non-isolated current position. Refer to [Figure 2-14](#).

Note

Unless otherwise specified, all models ship with this jumper in the non-isolated current position (Pin 2 and Pin 3 jumped). Refer to [Figure 2-14](#).

Figure 2-14: Jumper Locations

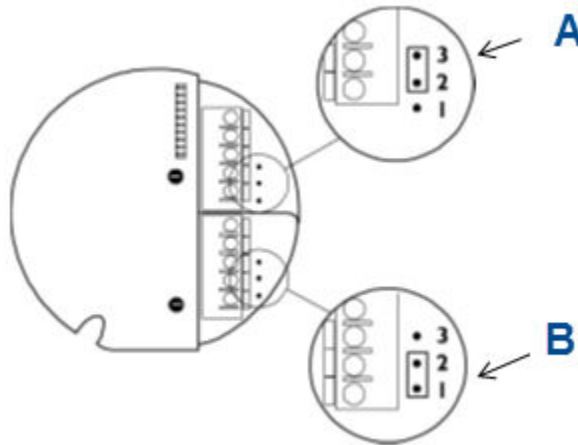

A. Jumper positions to set power source for current output.

Isolated and non-isolated current jumper - place jumper (shorting jack) over Pin 3 and Pin 2 (default position) for non-isolated configuration (source).

B. Place jumper over Pin 1 and Pin 2 for remaining configurations. Refer to [Figure 2-1](#).

2.7 Non-isolated and isolated power configurations

For current source using non-isolated configuration, the jumper must remain in the default position (Pin 2 and Pin 3 jumped). The jumper is placed over Pin 1 and Pin 2 for current sink using non-isolated configuration.

For isolated configuration using a separate power supply to isolate the current loop, the jumper must be placed over Pin 1 and Pin 2 for source and sink. Refer to [Figure 2-15](#), [Figure 2-16](#), [Figure 2-17](#), and [Figure 2-16](#).

Note the jumper position for each configuration.

Figure 2-15: Detector Non-Isolated Configuration (Source)

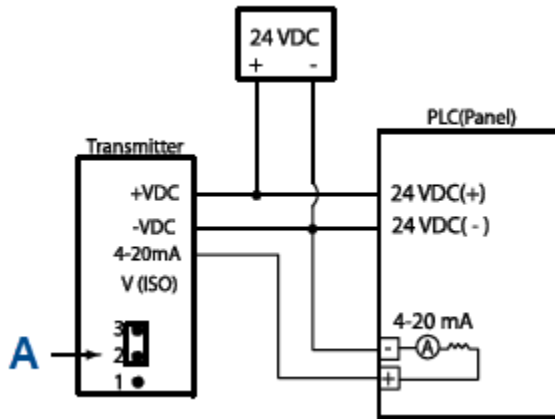

A. Isolated and non-isolated jumper pins

Figure 2-16: Detector Non-Isolated Configuration (Sink)

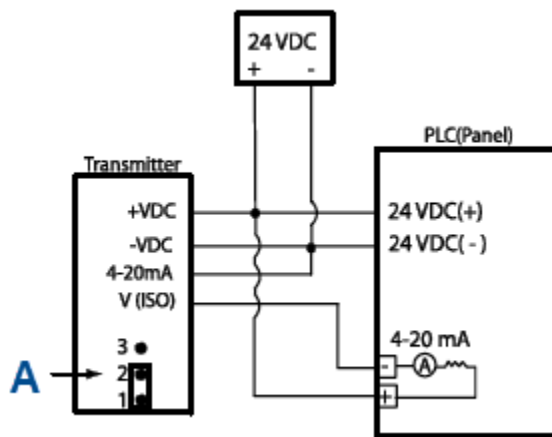

A. Isolated and non-isolated jumper pins

Figure 2-17: Detector Isolated Configuration (Source)

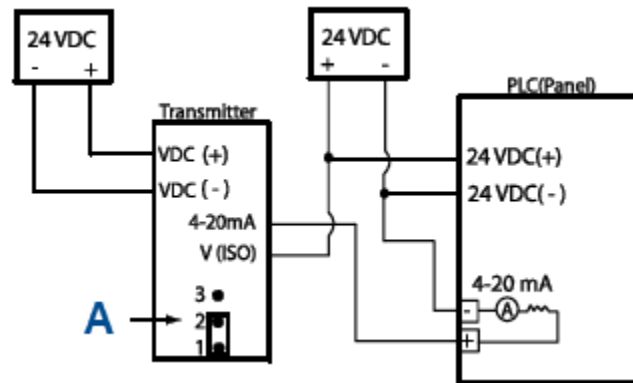

A. *Isolated and non-isolated jumper pins*

Figure 2-18: Detector Isolated Configuration (Sink)

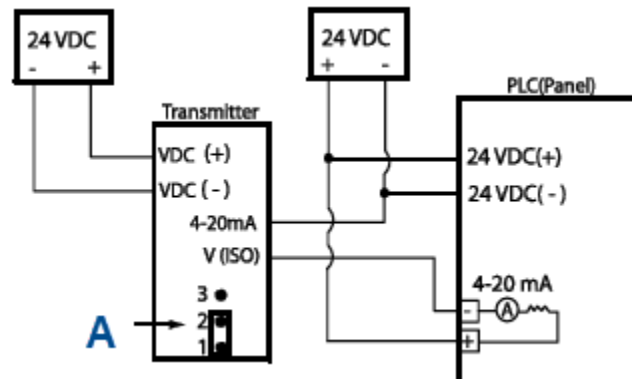

A. *Isolated and non-isolated jumper pins*

2.8 Installation checklist

Review the following checklist prior to turning the power on to the transmitter after installation has been completed:

- Ensure that the transmitter and sensor are properly and firmly mounted.
- Ensure that stopping plugs are securely tightened on any unused conduit entries.
- Ensure that the transmitter and sensor are not obstructed, such that they are accessible and the particulate matter is not inhibited from reaching the sensors optical path.
- Ensure adherence to applicable local guidelines and requirements on wiring and sealing of equipment in hazardous and non-hazardous areas.

- Ensure that proper shielding and grounding practices are adhered to and local codes are being followed.
- Check system operational voltage and conditions and ensure that they are within the applicable specifications of the transmitter and sensor.
- Verify wiring at all termination and junction points (transmitter, junction box, and power supply).
- Ensure that the transmitter housing cover and sensor cap are tightly secured.

3 Operation

3.1 Net Safety™ Millennium Transmitter

⚠ WARNING!

EXPLOSION

Do not open the transmitter, sensor, or junction box enclosure when in a classified area or when an explosive atmosphere may be present unless the power to the transmitter has been removed.

Figure 3-1 outlines the components on the Net Safety Millennium Transmitter, and the subsequent sections provide explanations for each component.

Figure 3-1: Net Safety Millennium Transmitter Layout

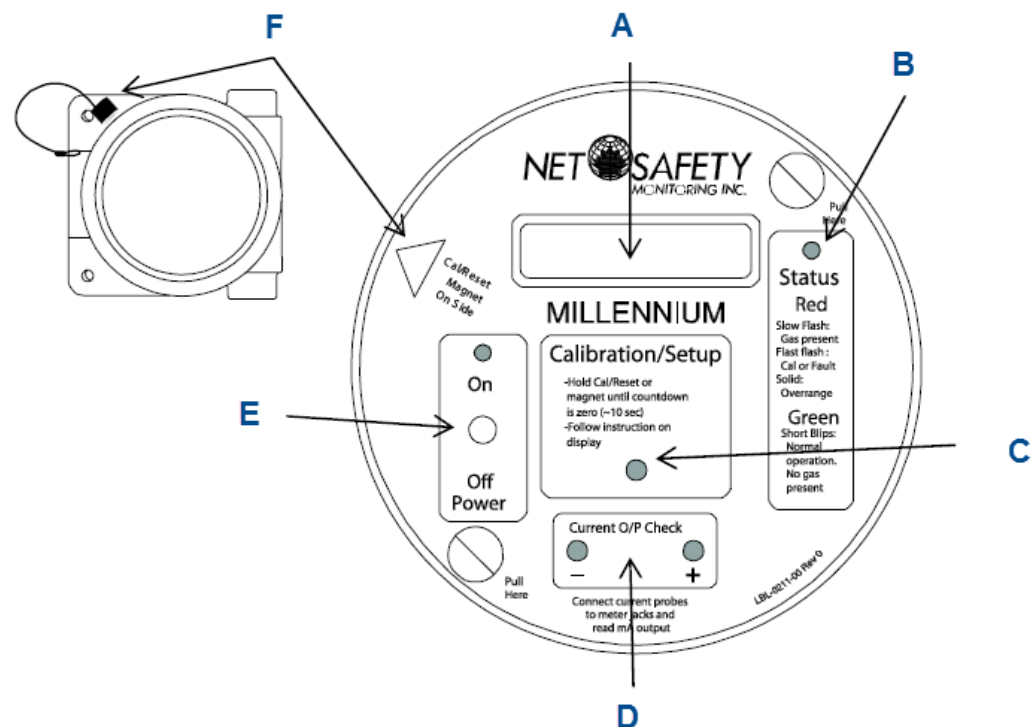

- A. [Section 3.1.1, Display](#)
- B. [Section 3.1.2, Status](#)
- C. [Section 3.1.4, Setup](#)
- D. [Section 3.1.6, Current output](#)
- E. [Section 3.1.3, On/off](#)
- F. [Section 3.1.5, Magnetic Reed switch](#)

3.1.1 Display

A scrolling 8 character display is provided to show various status messages and prompts. Refer to [Table 3-1](#) for the various display messages.

3.1.2 Status LED

The status LED is used to provide visual indication as to the status of the transmitter and sensor. Refer to [Section 3.2](#) for specific status conditions of the LED.

3.1.3 On/Off switch

The **On/Off** switch is used to turn power on and off to the transmitter and sensor. As the transmitter's housing must be opened to access the **On/Off** switch, the area where the transmitter is located must be de-classified prior to using.

3.1.4 Setup button

The **Setup** button provides access to the Net Safety Millennium Transmitter's main menu, which in turn allows options to be reviewed and set. The **Setup** button is also used to zero the sensor. As the transmitter's housing must be opened to access the button, the area must be de-classified before using. Refer to [Chapter 4](#) for instructions on programming the Net Safety Millennium Transmitter.

3.1.5 Magnetic Reed switch

Emerson provides the magnetic Reed switch to avoid opening the housing in an environment where gas may be present. The magnetic Reed switch functions in the same manner as the **Setup** button but in a non-intrusive manner. The magnet comes permanently attached to the side of the transmitter.

3.1.6 Current output check

Current output check test jacks are provided to facilitate current loop measurements without breaking external current loop. To take current loop measurements, ensure wiring is correct and current loop is closed, and then follow steps below

- Set meter on mA scale and insert meter leads into test jacks.
- Put external devices in bypass, if necessary, to avoid unwanted alarm response.
- Perform simulated tests to check output.
- Remove meter leads from test jacks and return external devices to normal.

3.2 Indications and outputs

Table 3-1: Transmitter Indications

State	Current Output	Status LED	Display
Main menu entered	3.0 mA	Solid green	Main menu items
Normal operation	4.0 mA	Green blip	Clear
Startup delay	3.0 mA	Slow red flash	Start delay
Dirty optics	3.3 mA	Fast red flash	Dirty chamber
Particulate present	20 mA	Red blip	Alarm
Fault condition	2.5 mA	Fast red flash	Fault
Updating Net Safety APM Sensor	3.0 mA	Slow red flash	Busy

3.3 Alarms

3.3.1 Net Safety APM fault

To ensure proper response, the Net Safety Millennium features self-testing circuitry that continuously checks for problems. When power is applied, the system automatically begins a test to ensure proper functionality.

During normal operation, the transmitter continuously monitors the signal from the internal APM source. If the transmitter determines that the APM program is not running correctly, it will reset the Net Safety APM Sensor.

3.3.2 Clean window/dirty chamber

Over an extended period, oily film or particulate build-up on the sensor window may obscure the detector. When dirty, the `Clean window` alarm trips, the message `Dirty Chamber` displays, the Status LED flashes fast red, and the current output is 3.3 mA. Refer to [Section 4.3.2](#) to define the clean window sensitivity and [Section 5.2](#) on cleaning the Net Safety APM window.

3.3.3 Particulate alarm

When particulate is present in the Net Safety APM's chamber, the message `Alarm` displays, the Status LED blips red, and the current output is 20.0 mA. If the relay has been set to non-latching, the unit resets itself; if set to latching, a manual or remote reset is required to clear the alarm condition. Refer to [Section 3.4](#).

Note

The Net Safety APM may be affected by sudden bursts of infrared light; therefore, Emerson recommends that a time delay [between two (2) and five (5) seconds] be put into the monitoring system to prevent nuisance alarms.

3.4 Reset

3.4.1 Remote reset

The Net Safety Millennium is capable of remote reset. A normally open push-button switch must be connected between the RST terminal and the COM terminal on the terminal board. If relay is set to Latching, a remote reset is possible.

3.4.2 Manual reset

If a relay is set to Latching, a manual reset is required to clear the alarm condition. Simply place and hold the magnet against the Reed switch or press and hold **Setup** for 3-5 seconds. The unit returns to normal operation.

3.5 Normal

With no particulate present and no fault detected, the display reads `Clear`, Status LED blips/blinks green, and the current output is 4.0 mA.

3.6 Outputs

3.6.1 Relays

All relay outputs have FORM-C SPDT contacts rated 5 amperes at 30 Vdc/250 Vac. Relays are dry contacts.

3.6.2 Current

A 4-20 mA dc current output is used to transmit the alarm status and fault conditions to other devices. This output can be wired for isolated or non-isolated operation. A 4.0 mA output indicates normal operation; a 20.0 mA output indicates that the alarm threshold has been exceeded. Current output of 2.5 mA indicates the presence of a system fault. Current output of 3.3 mA indicates a build-up of particulate in the sensor's chamber or dirty window. Refer to [Section 3.2](#) for additional indications and outputs.

3.7 Net Safety APM Sensor

3.7.1 Sensor power up

When the transmitter applies power to the sensor, a warm-up routine begins, and the sensor is automatically tested to ensure proper functioning. The warm-up time for the Net Safety APM Sensor is typically one hundred fifty (150) seconds. After the warm-up cycle has completed, the display reads `Clear`.

As part of the self-diagnostic routine of the Net Safety Millennium Transmitter, the analog output outputs 20 mA on initial power up for a period not greater than 450 milliseconds. If routine power loss is expected on the system, take appropriate actions to limit false alarm conditions due to this diagnostic routine.

3.7.2 Sensor communication

The Net Safety APM Sensor uses a proprietary protocol to communicate with the Net Safety Millennium Transmitter. Never connect the Net Safety APM Sensor to any device other than a Net Safety Millennium Transmitter. If any problems develop, please refer to [Section 5.3](#).

4 Programming

4.1 Main menu

The main menu provides access to various functional settings and viewing of current settings. The following options/settings are available in the main menu.

- Set Zero
- Sensitivity Settings
- Review Relay Settings
- Set Relay Options
- Select Display Language

4.2 Accessing the main menu

There are two ways to access the main menu: using the **Setup** button on the faceplate of the transmitter or using the magnetic Reed switch.

- Press and hold the **Setup** button to access the main menu.
- Place and hold the magnet to the transmitter's housing (10 o'clock position as shown in [Figure 3-1](#)) to access the main menu.

4.3 Using the main menu

The following steps outline the actions required to navigate through the menu system. Refer to [Figure 4-1](#) for the programming flow chart for the Net Safety Millennium Transmitter.

Figure 4-1: Programming Flowchart

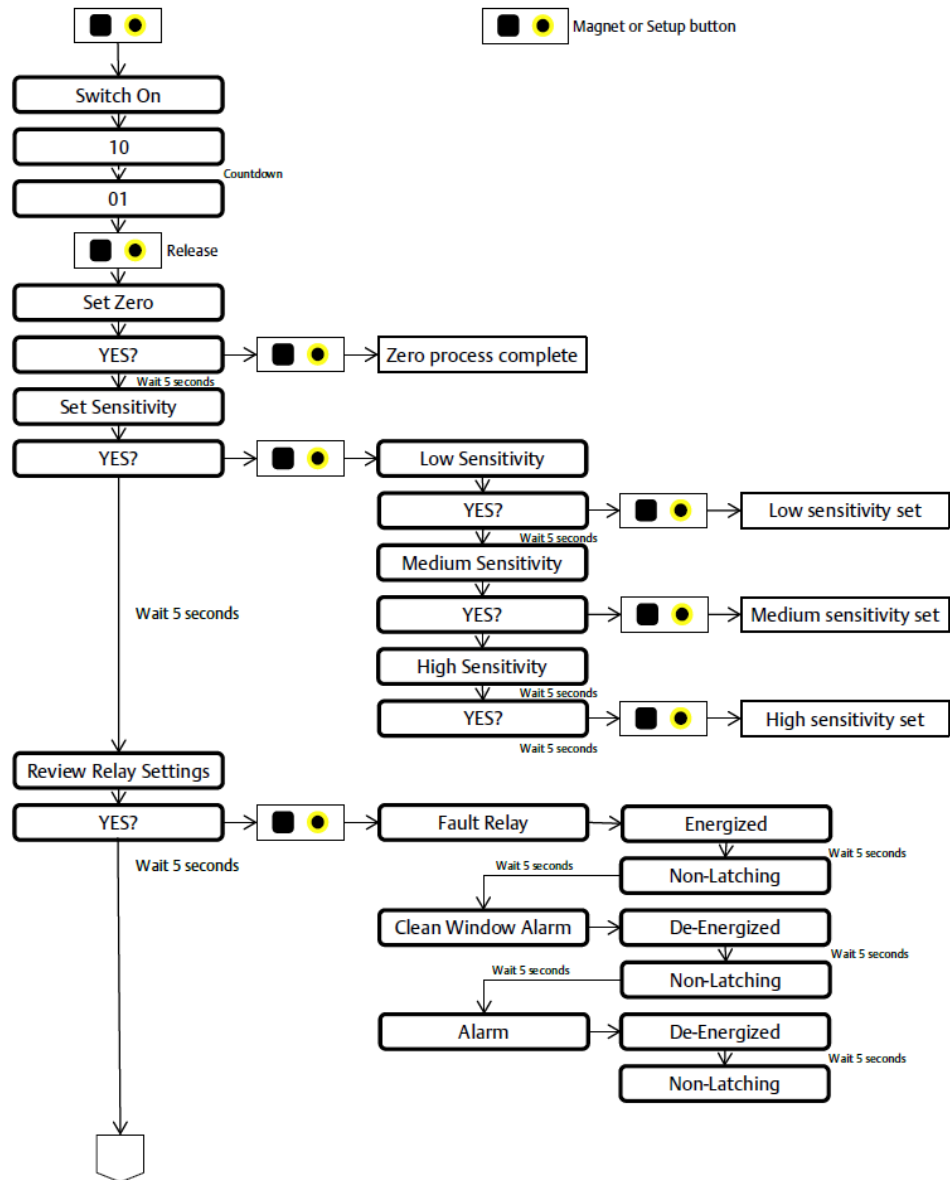

Prerequisites

Ensure that the transmitter is turned on and that no fault is present. If a fault is present, the menu system isn't accessible.

Procedure

1. Press and hold **Setup** or hold the magnet next to the triangle on the faceplate as shown in *Figure 3-1* until the message `Switch On` displays and the countdown (10 to 0) finishes.

An option scrolls across the display followed by the prompt `YES?`

2. To set/view an option, press **Setup** or place the magnet to the Reed switch at the `YES?` prompt. If you do not wish to select that option, wait five (5) seconds until the next option appears and then select `YES?`.

A selection is acknowledged with a flashing `YES`.

If no option is selected, the transmitter returns to the normal operational mode, and the display reads `Clear`.

Important

When the menu system has been entered, the current output changes to 3 mA. Ensure that external systems are bypassed, as required, prior to entering the menu system.

4.3.1 Zero

If at any time the background particulate levels change, the transmitter may be zeroed to the new levels. Emerson recommends zeroing every 3 months.

Important

After initial power-up, allow the unit to warm up for two to four hours before zeroing.

If the sensor has been in operation for a period of time, Emerson recommends that you clean the window as outlined in [Section 5.2](#).

Be sure the Net Safety APM is energized up and is not indicating a fault; e.g. the display reads `Clear`, the status LED is blinking green, and the current output is 4.0 mA.

Prior to beginning the zeroing procedure, ensure that the air surrounding the Net Safety APM is clean and free of particulate or at the accepted background level for the specific application.

The following steps outline the procedure to perform a zero of the Net Safety APM Sensor.

Procedure

1. Press and hold **Setup** or the magnet to the Reed switch to enter the main menu; wait for the countdown, from 10 to 0, to end.
2. Release **Setup** or remove the magnet from the Reed switch.

The current output moves to 3.0 mA.

3. When `Set Zero` and then `YES?` is displayed, press **Setup** or use the Reed switch to select this option.

A flashing `YES` confirms your selection.

The Net Safety APM has now been zeroed, meaning that the existing level of air contamination is considered normal.

Tip

If your application has a constant level of particulate present that is required to be ignored by the APM you can set the zero level with the known particulate present as shown in [Figure 4-2](#).

To further fine tune the Net Safety APM response for your requirements, adjust the sensitivity settings accordingly. Refer to [Section 4.3.2](#).

Figure 4-2: Zero Level Setting

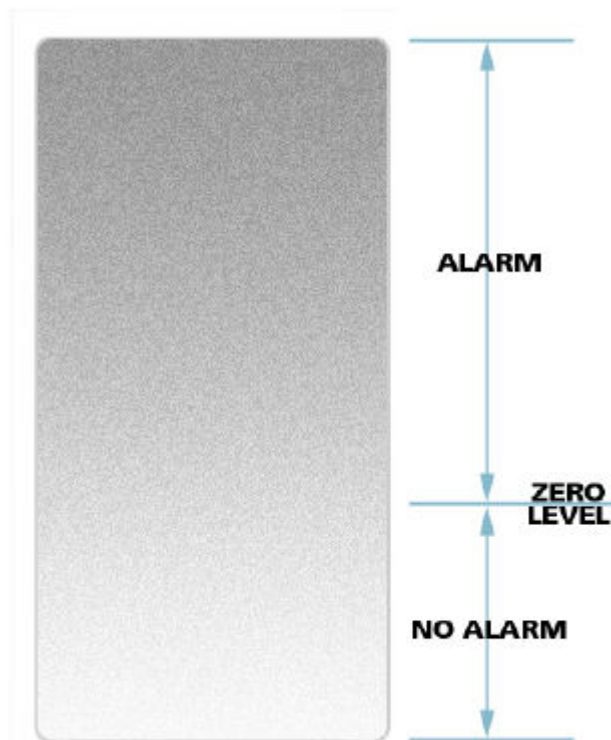

4.3.2 Sensitivity settings

The Net Safety APM can be set to detect low, medium or high sensitivity levels with high being the most sensitive. By default the sensitivity is set for high sensitivity from the factory. Follow the steps below to change the sensitivity.

1. Press and hold **Setup** or the magnet to the Reed switch to enter the main menu; wait for the countdown, from 10 to 0, to end.
2. Release **Setup** or remove the magnet from the Reed switch.

The current output moves to 3.0 mA.

3. When `Sensitivity Settings` and then `YES?` is displayed, press **Setup** or use the Reed switch to select this option.

A flashing `YES` confirms your selection.

4. The following three options display: Low Sensitivity YES? , Medium Sensitivity YES? and High Sensitivity YES?
5. When the required setting is displayed, press **Setup** button or use the Reed switch to select.

The selection is acknowledged with a flashing YES.

4.3.3 Review relay settings

This is a read-only mode to provide a summary of the relay settings. Changes to the relay settings cannot be made in this menu item.

Procedure

1. Press and hold **Setup** or the magnet to the Reed switch to enter the main menu; wait for the countdown, from 10 to 0, to end.
2. Release **Setup** or remove the magnet from the Reed switch.

The current output moves to 3.0 mA.

3. When `Review Relay Settings` and then YES? is displayed, press **Setup** or use the Reed switch to select this option.

A flashing YES confirms the selection, and the settings are displayed.

4.3.4 Set relay options

This section outlines how to change the normal operation of the Clean Window and Alarm relays.

Follow the steps below to alter the relay functions or refer to [Figure 4-1](#).

Note

The Fault Alarm relay settings are fixed as normally Energized and Non-Latching and are not adjustable within the menu system.

Procedure

1. Press and hold **Setup** or the magnet to the Reed switch to enter the main menu; wait for the countdown, from 10 to 0, to end.
2. Release **Setup** or remove the magnet from the Reed switch.

The current output moves to 3.0 mA.

3. When `Set Relay Options` and then YES? is displayed, press **Setup** or use the Reed switch to select.

A flashing YES confirms your selection. The message `Set Clean Window Alarm` and then YES? are displayed.

4. Press **Setup** or use the Reed switch to select this option.

The flashing `YES` confirms this selection. After the Clean Window Alarm option has been chosen, the message `Coil Status` is displayed followed by `Energized YES?`.

5. To select that the relay be energized under normal conditions, press **Setup** or use the Reed switch to select this option.

To select that the relay be de-energized under normal conditions wait five (5) seconds for the next selection. If `Energized` has been selected, a flashing `YES` confirms the selection.

6. To select that the relay be de-energized under normal conditions, press **Setup** or use the Reed switch to select this option.

If the relay is setup as required, wait five (5) seconds for the next selection. If `De-energized` has been selected, a flashing `YES` confirms the selection.

The display now shows `Latch Status`, followed by `Latching YES?`.

7. To select that the relay be latched in its alarm state, press **Setup** or use the Reed switch to select this option.

To select that the relay be non-latching, wait five (5) seconds for the next selection. If `latching` has been selected, a flashing `YES` confirms the selection.

8. To select that the relay be non-latching, press **Setup** or use the Reed switch to select this option.

If the relay is setup as required, wait five (5) seconds for the next selection. If you selected `Non-latching`, a flashing `YES` confirms the selection.

The message `Set Alarm` and then `YES?` are displayed.

9. Press **Setup** or use the Reed switch to select this option.

A flashing `YES` confirms this selection. After the `Set Alarm` option has been chosen, the message `Coil Status` is displayed, followed by `Energized YES?`.

10. To select that the relay be energized under normal conditions, press **Setup** or use the Reed switch to select this option.

To select that the relay be de-energized under normal conditions, wait five (5) seconds for the next selection. If you selected `Energized`, a flashing `YES` confirms the selection.

11. To select that the relay be de-energized under normal conditions, press **Setup** or use the Reed switch to select this option.

If the relay is setup as required, wait five (5) seconds for the next selection. If you selected `De-energized`, a flashing `YES` confirms the selection.

The display now shows `Latch Status`, followed by `Latching YES?`.

12. To select that the relay be latched in its alarm state, press **Setup** or use the Reed switch to select this option.
 To select that the relay be non-latching, wait five (5) seconds for the next selection. If you selected Latching, a flashing `YES` confirms the selection.
13. To select that the relay be non-latching, press **Setup** or use the Reed switch to select this option.
 If the relay is setup as required, wait five (5) seconds for the next selection. If you selected Non-latching, a flashing `YES` confirms the selection.

4.3.5 Select display language

This section outlines how to change the main display language to English, Spanish, or French. Follow the steps below to change the display language.

1. Press and hold **Setup** or the magnet to the Reed switch to enter the main menu; wait for the countdown, from 10 to 0, to end.
2. Release **Setup** or remove the magnet from the Reed switch.
 The current output moves to 3.0 mA.
3. When `Select Display Language` and then `YES?` is displayed, press **Setup** or use the Reed switch to select.
 A flashing `YES` confirms your selection. The messages `English` and then `YES?` are displayed.
4. Press **Setup** or use the Reed switch to select this option.
 The flashing `YES` confirms this selection.
5. If English is not the desired language, wait five (5) seconds for the next selection.
 The message `Espanol` and then `YES?` are displayed.
6. Press **Setup** or use the Reed switch to select this option.
 The flashing `YES` confirms this selection.
7. If Spanish is not the desired language, wait five (5) seconds for the next selection.
 The messages `Francais` and then `YES?` are displayed.
8. Press **Setup** or use the Reed switch to select this option.
 The flashing `YES` confirms this selection.
9. If French is not the desired language, wait five (5) seconds for the next selection.

5 Maintenance

5.1 Response check

Emerson™ recommends that you check and test the Net Safety™ APM at least once every three months.

Spray Smoke Detector Tester (or equivalent product) in the direction of the sensor from a distance of two feet. Typically, a one to two second burst is adequate to initiate an alarm.

When the alarm activates, the display reads `Alarm`, the Status LED flashes red, and the current output is 20.0 mA to indicate detection of particulate matter or canned contaminant.

After simulation, reset the alarm if latched as outlined in [Section 3.4](#) and zero the Net Safety APM as per [Section 4.3.1](#) in clear air free of particulates or at the accepted particulate background level for the specific application.

⚠ CAUTION!

EQUIPMENT DAMAGE

The overuse of artificial particulate detector testers or spraying from too close a range may impair the operation of the Net Safety APM due to the accumulation of an oily film on the internal window.

5.2 Cleaning

Clean the Net Safety APM sensor routinely. The frequency of cleaning depends on the application and environment where the Net Safety APM is installed.

When the `Dirty Chamber` or `Clean Window Alarm` message is displayed, the lens / window and chamber require cleaning. Follow the steps below when cleaning.

Procedure

1. Turn off power to the transmitter.
2. Unscrew bolts at the end of circular plate and connecting rods.
3. Using conventional multi-purpose or glass cleaning solution, clean the inner sides of the sensor chamber and front side of the lens / window.

Use a lint-free towel or sponge to apply the cleaning solution.
4. Ensure that there is no residue left on the lens or window.
5. Put the circular plate back into position, ensuring that the textured surface faces the Net Safety APM window, and screw in the bolts at the end of the connecting rods.
6. Return power to the Net Safety APM and check for normal operation.

7. Complete the Zero procedure ([Section 4.3.1](#)) to establish new settings.
If problems develop and persist, contact the Net Safety Service department or refer to [Section 1.3](#) (Return of material).

5.3 Troubleshooting

The Net Safety Millennium Transmitter and Net Safety APM Sensor are not designed to be repaired in the field. If a problem should develop, carefully check for faulty wiring. If it is determined that the problem is caused by an electronic defect, return the device to the factory for repair (refer to [Section 1.2](#) and [Section 1.3](#) for instructions).

Perform regular checks on the unit around every two to three months to ensure desired operation. Refer to [Section 5.1](#) for instructions.

5.4 Storage

Store the sensor and its electronic components/parts in locations free from dust and moisture. Ensure that the storage temperature is well within the limits of the certified temperatures of the equipment. See [Chapter 8](#) for storage temperatures.

5.5 Spare parts and accessories

Table 5-1: Spare Parts and Accessories

Description	Part Number
Universal duct mount assembly with 3.3 ft. (1 m) inlet sampling tube	UDM-001
Universal duct mount assembly with 4.9 ft. (1.5 m) inlet sampling tube	UDM-002
Universal duct mount assembly	UDM-003
Magnet assembly	HDW-0118
Replacement Millennium transmitter board	ML7-TX700
Terminal board for JB-MPD	JB-MPD-PCBA
316 stainless steel termination junction box	JB-MPD-S
Conduit reducer - ¾ in. (19 mm) to M20 - nickel-plated brass	HDW-0148
Conduit reducer - ¾ in. (19 mm) to M20 - stainless steel	HDW-0147

6 Electrostatic sensitive device

Electrostatic discharge (ESD) is the transfer, between bodies, of an electrostatic charge caused by direct contact or induced by an electrostatic field.

The most common cause of ESD is physical contact. Touching an object can cause a discharge of electrostatic energy. If the charge is sufficient and occurs near electronic components, it can damage or destroy those components. In some cases, damage is instantaneous, and an immediate malfunction occurs. However, symptoms are not always immediate—performance may be marginal or seemingly normal for an indefinite period of time, followed by a sudden failure.

To eliminate potential ESD damage, review the following guidelines:

- Handle boards by the sides — taking care not to touch electronic components.
- Wear grounded wrist or foot straps, ESD shoes, or heel grounders to dissipate unwanted static energy.
- Prior to handling boards, dispel any charge in your body or equipment by touching a grounded metal surface.
- Ensure all components are transported and stored in ESD safe packaging.
- When returning boards, carefully package in the original carton and static protective wrapping.
- Ensure all personnel are educated and trained in ESD control procedures.
- Clean off the housing with a damp cloth only.

In general, exercise accepted and proven precautions normally observed when handling electrostatic sensitive devices.

7 Wire resistance table

Distance Meters (Feet)	AWG #20 0.5 mm²	AWG #18 0.8 mm²	AWG #16 1.0 mm²	AWG #14 2.0 mm²
30.5 (100)	1.02	0.64	0.40	0.25
61 (200)	2.03	1.28	0.80	0.51
91.4 (300)	3.05	1.92	1.20	0.76
121.9 (400)	4.06	2.55	1.61	1.01
152.4 (500)	5.08	3.20	2.01	1.26
182.9 (600)	6.09	3.83	2.41	1.52
213.4 (700)	7.11	4.47	2.81	1.77
243.8 (800)	8.12	5.11	3.21	2.02
274.3 (900)	9.14	5.75	3.61	2.27
304.8 (1,000)	10.20	6.39	4.02	2.53
381 (1,250)	12.70	7.99	5.03	3.16
457.2 (1,500)	15.20	9.58	6.02	3.79
533.4 (1,750)	17.80	11.20	7.03	4.42
609.6 (2,000)	20.30	12.80	8.03	5.05
685.8 (2,250)	22.80	14.40	9.03	5.68
762 (2,500)	25.40	16.00	10.00	6.31
914.4 (3,000)	30.50	19.20	12.00	7.58
1066.8 (3,500)	35.50	22.40	14.10	8.84
41292.2 (4,000)	40.60	25.50	16.10	10.00
1371.6 (4,500)	45.70	28.70	18.10	11.40
5,000 (1,524)	50.10	32.00	20.10	12.60
1676.4 (5,500)	55.80	35.10	22.10	13.91
1828.8 (6,000)	61.00	38.30	24.10	15.20
1981.2 (6,500)	66.00	41.50	26.10	16.40
2133.6 (7,000)	71.10	44.70	28.10	17.70
2286 (7,500)	76.10	47.90	30.10	19.00
2438.4 (8,000)	81.20	51.10	23.10	20.20
2743.2 (9,000)	91.40	57.50	36.10	22.70
3048 (10,000)	102.00	63.90	40.20	25.30

Resistance shown is one way. This figure must be doubled when determining closed loop resistance.

8 Specifications

Table 8-1: Electrical Specifications

Specification	Value
Operating voltage range	10.5 to 32 Vdc
Power consumption	3.24 W max at 12 Vdc 3.6 W max at 24 Vdc
Current output	4-20 mA into a maximum loop impedance of 800 Ohms at 32 Vdc or 150 Ohms at 10.5 Vdc isolated or non-isolated loop supply

Table 8-2: Environmental Specifications

Specification	Transmitter	APM sensor	Junction box
Storage temperature	-40 °C to +85 °C (-40 °F to +185 °F)	-40 °C to +75 °C (-40 °F to +167 °F)	-40 °C to +85 °C (-40 °F to +185 °F)
Operating temperature	-40 °C to +85 °C (-40 °F to +185 °F)	-40 °C to +75 °C (-40 °F to +167 °F)	-40 °C to +85 °C (-40 °F to +185 °F)
Relative humidity	0-100% relative humidity, non-condensing		

Metallurgy

Aluminum (AL6061 - sensor, A413 - junction box)

Stainless steel (SS316)

Table 8-3: Ingress Protection

Product	Ingress protection rating
Transmitter	<ul style="list-style-type: none"> Type 4X IP66 IP67 (IECEX stainless steel)
Junction box	<ul style="list-style-type: none"> Type 4X IP67
APM sensor	<ul style="list-style-type: none"> Type 4X IP65

Table 8-4: Weight

Product	Weight
Transmitter	Stainless steel: 7.0 lb (3.2 kg)
APM sensor	Stainless steel: 4.0 lb (1.8 kg)
Junction box	Stainless steel: 3.5 lb (1.6 kg)

Separation

Up to 610 meters (2,000 feet) with 16 AWG (1.31 mm²) wire

Warranty

Electronics: 3 years

Sensors: 2 years

9 Certifications

9.1 North American hazardous locations

9.1.1 Transmitter



Class I, Division 1, Groups B, C, and D T5

Class I, Zone 1 Ex d IIB+H₂ T5 AL Version Only

-40 °C ≤ Ta ≤ +75 °C

Type 4X

9.1.2 APM Sensor



Class I, Division 1, Groups B, C, and D T5

Class I, Zone 1, AEx db IIB+H₂ T5 Gb

Ex db IIB+H₂ T5 Gb

IP65, Type 4X

-40 °C ≤ Ta ≤ +75 °C

9.1.3 Junction box (Model JB-MPD)



Class I, Division 1, Groups B, C, and D Class I Zone 1, AEx d/Ex d IIB+H₂ T5

-50 °C ≤ Ta ≤ +85 °C

Type 4X, IP67

9.2 ATEX (-X model)

9.2.1 Transmitter

CE 1180 II 2 G Ex d IIB+H₂ T5, IP66

-40 °C ≤ Ta ≤ +85 °C

Presafe 16 ATEX 8594X

9.2.2 APM Sensor

CE 1180 II 2 G Ex db op is IIB+H₂ T4 Gb

-40 °C < Ta < +75 °C

IP65

SIRA 17ATEX1242X

EN 60079-0:2012/A11:2013

EN 60079-1:2014

Special conditions for safe use

1. The integral conductors shall be suitably mechanically protected and terminated in a suitable certified terminal or junction facility.
2. It is the user's responsibility to ensure that the earth continuity of the equipment is maintained via the mounting arrangement.
3. Flamepath joints are not intended to be repaired.

9.2.3 Junction box (Model JB-MPD)



CE 1180  II 2 G Ex d IIB+H₂ T5

-55 °C ≤ Ta ≤ +85 °C IP67

FM07ATEX0044

9.3 IECEx (-X model)

9.3.1 Transmitter (aluminum)

Ex d IIB+H₂ T5 Gb

-40 °C ≤ Ta ≤ +85 °C

Certificate Number: IECEx DNV 12.0014

IEC 60079-0: 2007-10/IEC 60079-1:2007-04

9.3.2 Transmitter (stainless steel)

Ex d IIB+H₂ T5 Gb

-55 °C ≤ Ta ≤ +85 °C

Certificate Number: IECEx FMG 13.0035X

IEC 60079-0:2011/IEC 60079-1:2007/IEC 60529:2001

Consult the manufacturer if dimensional information on the flameproof joints is necessary.

9.3.3 APM Sensor

Ex db op is IIB+H₂ T4 Gb

-40 °C ≤ Ta ≤ +75 °C

IP65

Certificate Number: IECEx SIR 17.0061X

IEC 60079-0:2011, 6th Edition

IEC 60079-1:2014, 7th Edition

IEC 60079-28:2015, 2nd Edition

9.3.4 Junction box (Model JB-MPD)

Ex d IIB+H₂ T5 Gb

Certificate Number: IECEX FMG 14.0009X

Consult the manufacturer if dimensional information on the flameproof joints is necessary.

Follow the manufacturer's instructions to reduce the potential of an electrostatic charging hazard.

10 Ordering information

Model	Description
MLP	Millennium Transmitter
Output	Description
AR	4-20 mA analog and particulate and fault alarm relays
Sensor	Description
APM	Air Particle Monitor
Optics	Description
OP	Optical protection
Separation	Description
SEP	Sensor separation
Housing	Description
SS	Stainless steel
Approvals	Description
	CSA
X	ATEX-IECEX

Note

Emerson Automation Solutions
 Rosemount
 6021 Innovation Blvd.
 Shakopee, MN 55379

Toll Free +1 866 347 3427

F +1 952 949 7001

www.Emerson.com/FlameGasDetection

GLOBAL HEADQUARTERS

Emerson Automation Solutions
Rosemount
6021 Innovation Blvd.
Shakopee, MN 55379

 Toll Free +1 866 347 3427

 +1 952 949 7001

 safety.csc@emerson.com

EUROPE

Emerson Automation Solutions
Neuhofstrasse 19a P.O. Box 1046
CH-6340 Baar
Switzerland

 +41 (0) 41 768 6111

 +41 (0) 41 768 6300

 safety.csc@emerson.com

MIDDLE EAST AND AFRICA

Emerson Automation Solutions
Emerson FZE
Jebel Ali Free Zone
Dubai, United Arab Emirates, P.O. Box 17033

 +971 4 811 8100

 +971 4 886 5465

 safety.csc@emerson.com

ASIA-PACIFIC

Emerson Automation Solutions
Asia Pacific Private Limited
1 Pandan Crescent
Singapore 128461
Singapore

 +65 777 8211

 +65 777 0947

 safety.csc@emerson.com

 [Linkedin.com/company/Emerson-Automation-Solutions](https://www.linkedin.com/company/Emerson-Automation-Solutions)

 twitter.com/rosemount_news

 [Facebook.com/Rosemount](https://www.facebook.com/Rosemount)

 [youtube.com/RosemountMeasurement](https://www.youtube.com/RosemountMeasurement)

 [google.com/+RosemountMeasurement](https://plus.google.com/+RosemountMeasurement)

 AnalyticExpert.com

©2018 Emerson. All rights reserved.

The Emerson logo is a trademark and service mark of Emerson Electric Co. Rosemount and Rosemount logotype are trademarks of Emerson. All other marks are property of their respective owners.