

MNU Ultrasonic Modbus Sensors User Manual

Table of Contents

Introduction	iii
Warranty and Warranty Restrictions	iv
Chapter 1: Specifications and Options.....	1
Dimensions	1
Specifications	2
Model Number Configurator.....	3
Electrical Pinout Table, Power Supply Table, and System Wiring Diagrams.....	3-5
Chapter 2: Installation and Removal Procedures and Notes.....	6
Tools Needed.....	6
Installation Notes	6
Electrical Installation	6
Mounting Instructions	7
Software Installation.....	7
Removal Instructions	7
Chapter 3: Programming	8
Modbus Programming	8
Modbus Programming via Internet with RST-5003 or LOE	8
Modbus Programming with RST-6001 and APG Modbus Software	9
MNU Modbus Register Lists	9-10
MNU Modbus Sensor Parameters.....	11-15
MNU Web / Independant Modbus Alarm Parameters	16-18
Configuring MNU Modbus Application Parameters	18-23
Chapter 4: Maintenance	24
General Care	24
Troubleshooting.....	24
Loss of Echo	24
Calibration	25
Repair and Returns.....	25

Introduction

Thank you for purchasing an MNU modbus series ultrasonic sensor from APG. We appreciate your business! Please take a few minutes to familiarize yourself with your MNU and this manual.

MNU ultrasonic sensors are rugged units, with a PC/PBT housing, 1"-3" NPT threads for mounting, and a NEMA 6P rating (protects against ingress of dripping, sprayed, and submersing water). All MNU sensors are fully programmable via RS-485 Modbus communications with APG Modbus software and an APG RST-6001 unit.

Reading your label

Every APG instrument comes with a label that includes the instrument's model number, part number, serial number, and a wiring pinout table. Please ensure that the part number and pinout table on your label match your order.

Warranty and Warranty Restrictions

This product is covered by APG's warranty to be free from defects in material and workmanship under normal use and service of the product for 24 months. For a full explanation of our Warranty, please visit <https://www.apgsensors.com/about-us/terms-conditions>. Contact Technical Support to receive a Return Material Authorization before shipping your product back.

Scan the QR code below to read the full explanation of our Warranty on your tablet or smartphone.

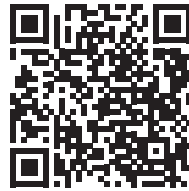

Chapter 1: Specifications and Options

- **Dimensions**

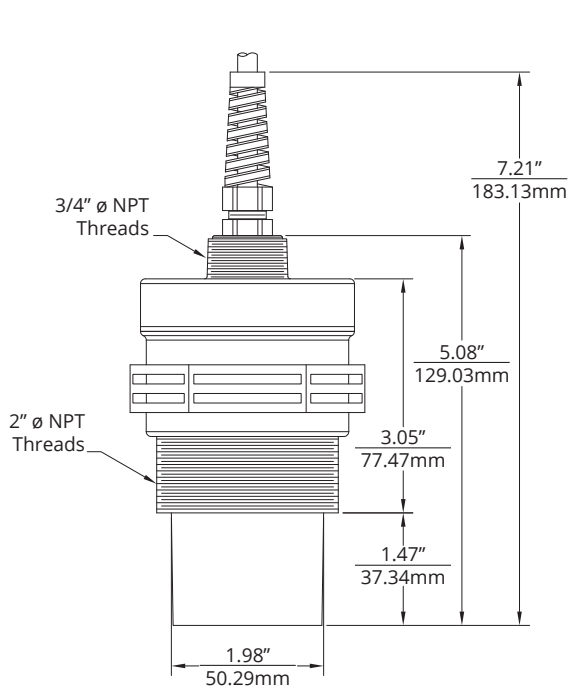

MNU-2424 & MNU-8424

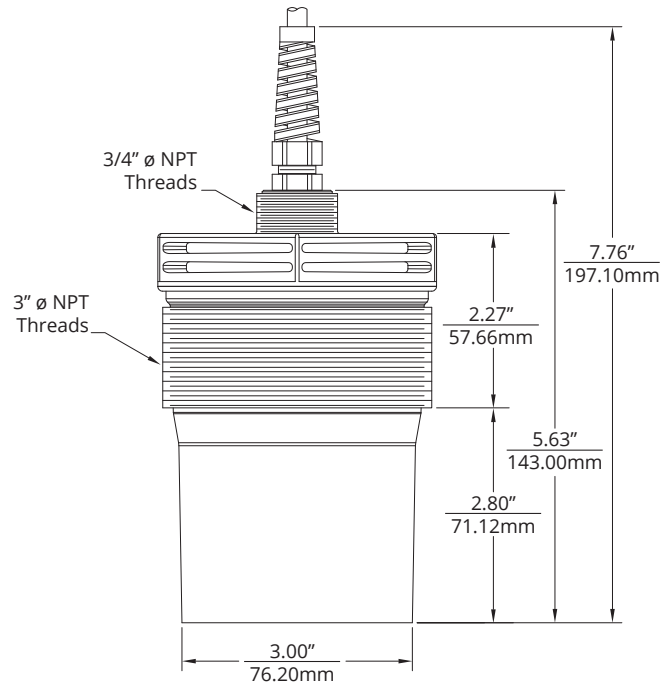

MNU-3434

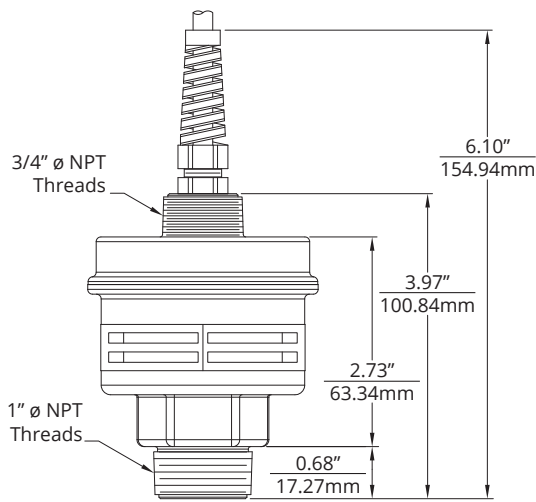

MNU-5414

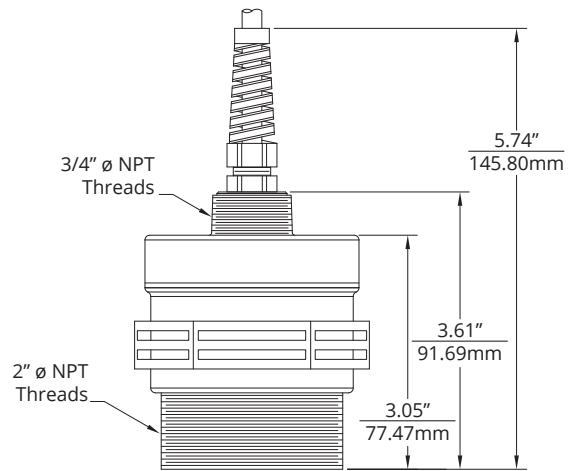

MNU-5424

• Specifications

Performance

Operating Range	0.3 - 6.6 ft. / 4 in. - 79 in. / 101mm - 2007mm (54x4) 0.42 - 12.0 ft. / 5 in. - 144 in. / 125mm - 3658mm (8424) 1.0 - 25.0 ft. / 12 in. - 300 in. / 305mm - 7620mm (2424) 1.5 ft. - 40 ft. / 18 in. - 480 in. / 458mm - 12192mm (3434)
Digital Output	Modbus, via RS-485
Beam Pattern	9° off axis
Transducer Frequency	43 kHz (3434) / 69 kHz (2424) / 81 kHz (8424) / 143 kHz (54x4)
Response Time	Programmable, 10 ms minimum (100 Hz)

Accuracy

Accuracy	±0.25% of detected range
Resolution	0.1 inch (2.54 mm)

Environmental

Operating Temperature	-34 to 60°C (-30 to 140°F)
Internal Temperature Compensation	Yes
NEMA rating	6P

Electrical

Operational Supply Voltage (at sensor)	8-24 VDC
Current Draw	35 mA max @ 12 VDC 20 mA max @ 24 VDC
Connection	2 Twisted Pair, or 4-pin Micro Connector

Materials of Construction

Transducer Housing	PBT/Polycarbonate blend
Transducer Type	Ceramic, PVDF faced (2424, 54x4, 8424) Ceramic, PBT/Polycarbonate faced (3434)

Mounting

MNU-2424	2" Ø NPT (front), 3/4" Ø NPT (rear)
MNU-3434	3" Ø NPT (front), 3/4" Ø NPT (rear)
MNU-5414	1" Ø NPT (front), 3/4" Ø NPT (rear)
MNU-5424	2" Ø NPT (front), 3/4" Ø NPT (rear)
MNU-8424	2" Ø NPT (front), 3/4" Ø NPT (rear)

- **Model Number Configurator**

Part Number: MNU - -
 A B

A. Model

- **2424** 1 - 25 ft. (305mm - 7620mm); 69 kHz; 2" NPT threads
- **3434** 1.5 - 40 ft. (458mm - 12192mm); 43 kHz; 3" NPT threads
- **5414** 0.3 - 6.6 ft. (101mm - 2007mm); 143 kHz; 1" NPT threads
- **5424** 0.3 - 6.6 ft. (101mm - 2007mm); 143 kHz; 2" NPT threads
- **8424** 5 - 144 in. (125mm - 3658mm); 81 kHz; 2" NPT threads

B. Cable/Micro Connector

- **CL** Specify Length (6 ft. standard length + 5 ft. increments)
- **M** Micro Connector (Mating connector cable sold separately)

- **Electrical Pinout Table, Supply Power Table, and System Wiring Diagrams**

MNU Series Pinout Table

		Modbus
Pigtail (2 Twisted Pairs)	Red	+ 24 VDC
	Black	DC Ground
	Green	B (TX-)
	White	A (TX+)
	Shield	Case Gnd
Micro Connector	1 Brown	+24 VDC
	2 White	A (TX+)
	3 Blue	DC Ground
	4 Black	B (TX-)

MNU Series Supply Power Table

	Modbus
Power Supply	8-24 VDC

Modbus System Wiring

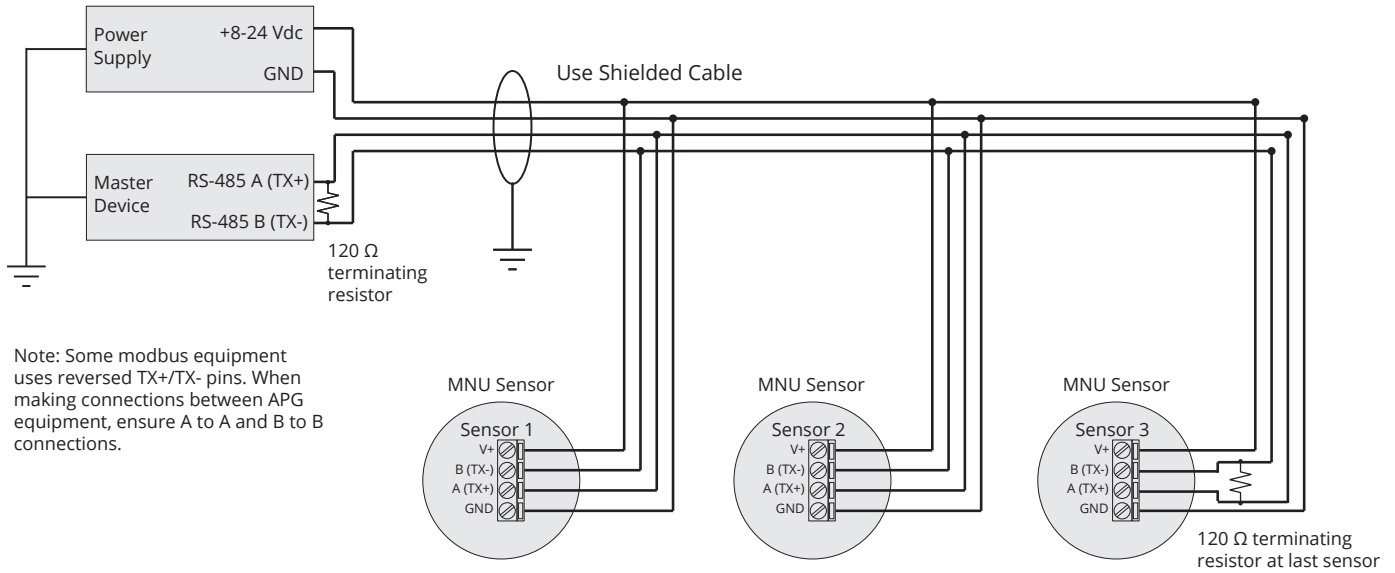

Modbus System Wiring with RST-6001

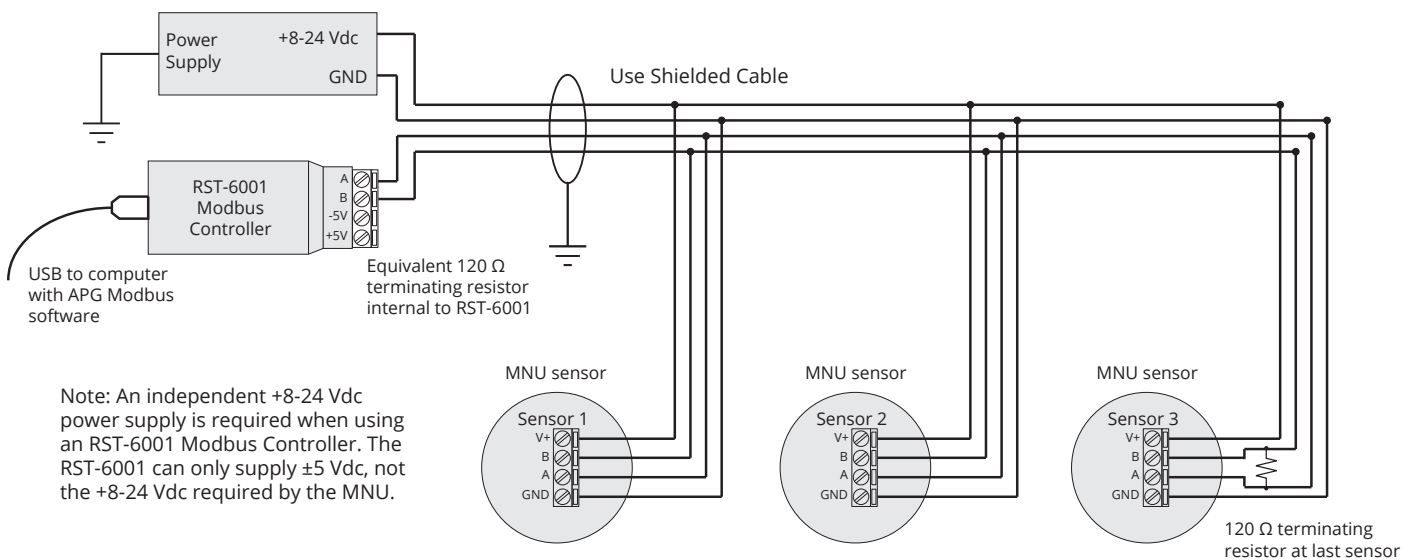

Modbus System Wiring with RST-5003 and Independent Power Supply

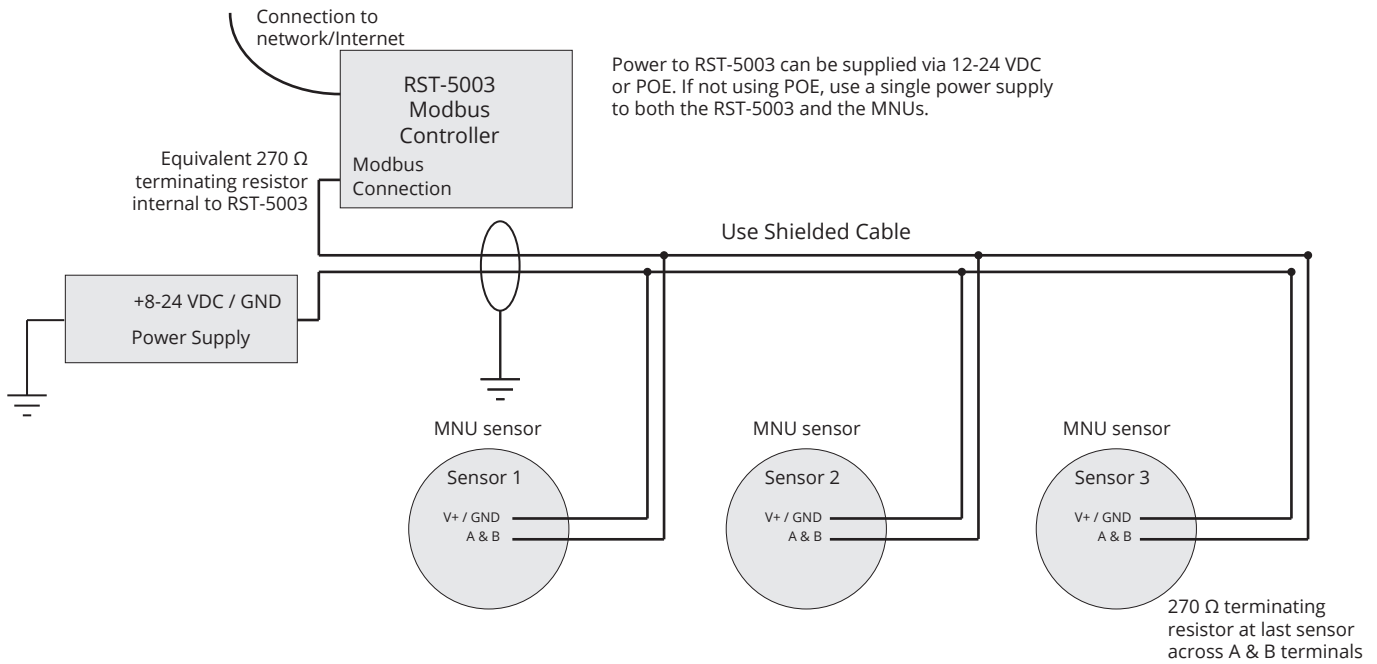

Modbus System Wiring with RST-5003 and POE or VDC Daisy Chain

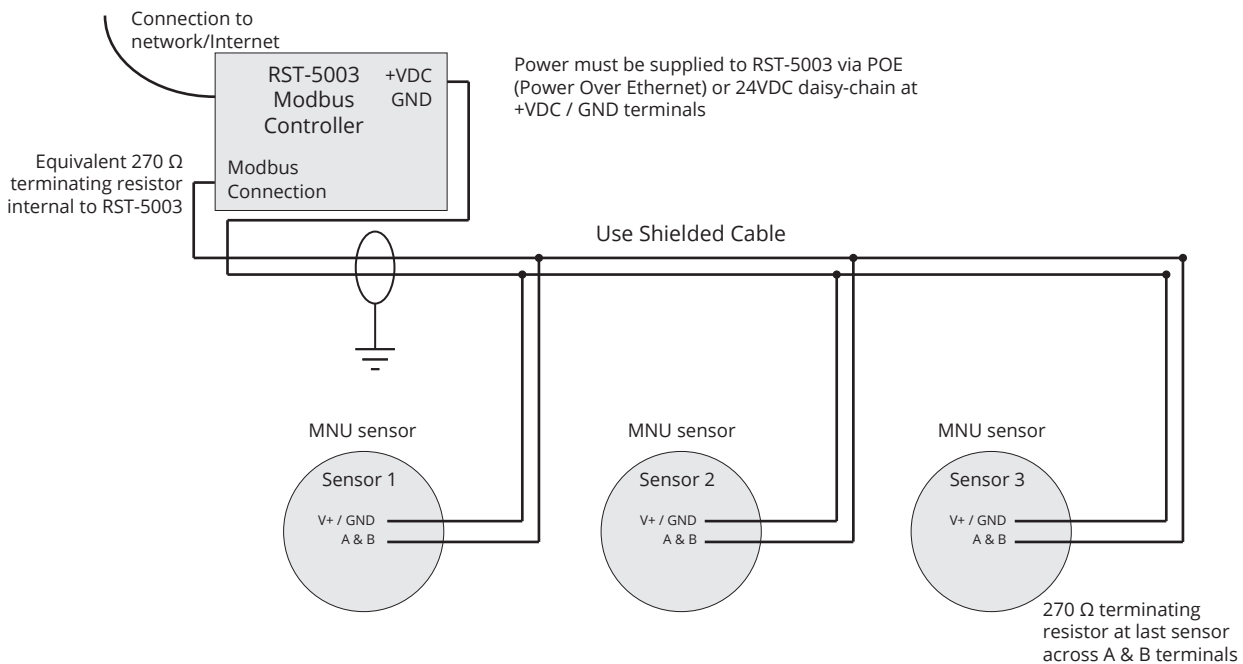

Chapter 2: Installation and Removal Procedures and Notes

• Tools Needed

- You should not need any tools to install your MNU. If you are using a stand pipe to mount your MNU, you will probably need tools to install the stand pipe.

• Installation Notes

- Mount your MNU sensor so that it has a clear, perpendicular sound path to the surface being monitored. Your sensor should be mounted away from tank or vessel walls and inlets. (See Figure 2.1)
- The sound path should be free from obstructions and as open as possible for the 9° off axis beam pattern.
- If you are using a stand pipe, please see our guide to stand pipes on our website: <http://www.apgsensors.com/about-us/blog/how-to-install-a-stand-pipe>.

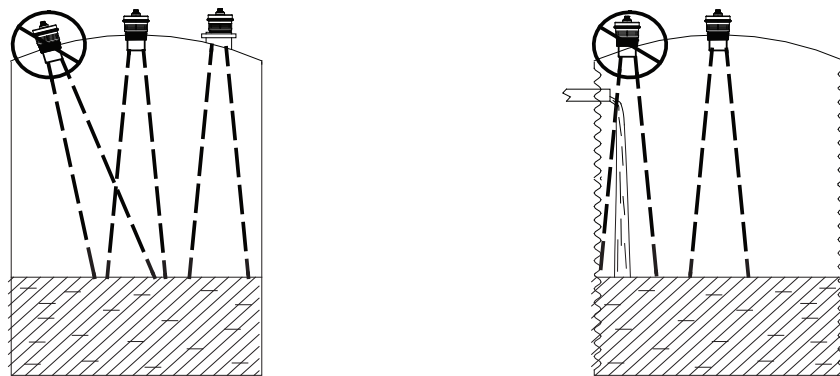

Figure 2.1

• Electrical Installation

- Attach the wires of your MNU to your control system according to the pinout table on page 3.

i IMPORTANT: Some modbus equipment uses reversed TX+/TX- pins. When making connections between APG equipment, ensure A to A and B to B connections. When connecting to other systems, if your MNU sensor will not communicate, reverse A & B connections at one end (Master OR Sensor, not both).

• **Mounting Instructions**

Mounting your MNU is easy if you follow a few simple steps:

- Never over-tighten the sensor.
- Always screw in your sensor by hand to avoid cross-threading. Thread failure can be a problem if you damage threads by over-tightening them or by crossing threads.

 **IMPORTANT:** Do not over tighten! The sensor should be threaded in only hand tight.

 **NOTE:** Do not mount the sensor where the beam will intersect objects such as fill streams, pipes, ladder rungs, wall seams, or corrugated tank walls.

• **Software Installation**

- Download the APG Modbus software zipfile from <http://apgsensors.com/support>.
- Open the zip file.
- Choose "Install" from the options at the top of the zip file window.
- The installation process will prompt you as needed to complete the installation.
- The software will create APG_Modbus.exe which will run from a folder in your start menu titled "APG/ APG_Modbus".

• **Removal Instructions**

- Ensure that power to the sensor is off.
- Disconnect cable to sensor.
- Remove the sensor and store it in a dry place, at a temperature between -30° F and 140° F.

 **DANGER:** This sensor is not certified for use in hazardous areas.

Chapter 3: Programming

- **Modbus Programming**

MNU modbus series sensors use standard Modbus RTU protocol (RS-485). The sensors can only operate as slave devices. Sensor default transmission settings are **9600 Baud, 8 Bits, 1 Stop Bit, No Parity**, and require a minimum delay of 300 ms between transactions to return the contents of all registers. Commands returning fewer registers will require shorter delays. See MNU Modbus Register Lists on pages 9 - 10.

 NOTE: For more information about Modbus RTU, please visit www.modbus.org.

- **Modbus Programming via Internet with RST-5003 or LOE**

MNU Modbus series sensors can be programmed, controlled, and monitored via the Internet (or local Ethernet) using an RST-5003 web-enabled Modbus master controller or LOE web-enabled Modbus master sensor. One RST-5003 or LOE can control and monitor up to 10 APG Modbus-equipped sensors. Please refer to the RST-5003 User Manual or LOE User Manual for further instructions and help setting up and operating an RST-5003 or LOE and using either one to program and control MNU sensors.

 NOTE: For the RST-5003 User Manual or LOE User Manual, please visit <http://apgsensors.com/support>.

- **Modbus Programming with RST-6001 and APG Modbus Software**

APG RST-6001 Modbus Controller can be used in tandem with the APG Modbus software to program and control up to 20 MNU sensors. Through the APG Modbus software, you can monitor the raw readings from the sensor, or configure the sensor. See MNU Modbus Register Lists below.

 **NOTE:** For APG Modbus programming instructions, or to download APG Modbus software, please visit www.apgsensors.com/support.

- **MNU Modbus Register Lists**

Input Registers (0x04)

Register	Returned Data
30299	Model Type
30300	Raw Distance/Level Reading (in mm, unsigned)
30301	N/A
30302	Temperature Reading (in °C, signed)
30303-30304	Calculated (raw)
30305-30306	N/A
30307 (upper bits)	Version
30307 (lower bits)	Signal Strength
30308	N/A
30309 (upper bits)	Trip 1 Alarm
30309 (lower bits)	Trip 1 Status
30310 (upper bits)	Trip 2 Alarm
30310 (lower bits)	Trip 2 Status

 **NOTE:** The Calculated Readings will be returned without a decimal place. In order to obtain the true result, the Decimal Place setting must be taken into account.

Holding Registers (0x03) - MNU

<u>Register</u>	<u>Function</u>	<u>Value Range</u>
40400	Device Address	1 to 247
40401	Units	1 = Feet, 2 = Inches, 3 = Meters
40402	Application Type	0 - 11
40403	Volume Units	1 - 7
40404	Decimal (Calculated)	0 - 3
40405	Max Distance	0 - 15,250 mm
40406	Full Distance	0 - 15,250 mm
40407	Empty Distance	0 - 15,250 mm
40408	Sensitivity	0 - 100
40409	Pulses	0 - 20
40410	Blanking	0 - 15,250 mm
40411	Gain Control	0 - 5
40412	Averaging	1 - 100
40413	Filter Window	0 - 15,250 mm
40414	Out of Range	1 - 255
40415	Sample Rate	10 - 1000 milliseconds
40416	Multiplier	1 - 1999 (1000 = 1.000)
40417	Offset	-15,250 - 15,250 mm
40418	N/A	
40419	N/A	
40420	Temperature Compensation	0 = No, 1 = Yes
40421	N/A	
40422-40423	N/A	
40424-40425	N/A	
40426	N/A	
40427	N/A	
40428	N/A	
40429	N/A	
40430	Trip 1 Value	0 - 15,250 (mm)
40431	Trip 1 Window	0 - 15,250 (mm)
40432	Trip 1 Type	0 - 29
40433	Trip 2 Value	0 - 15,250 (mm)
40434	Trip 2 Window	0 - 15,250 (mm)
40435	Trip 2 Type	0 - 29
40436-40437	Parameter 1	0 - 1,000,000 (mm)
40438-40439	Parameter 2	0 - 1,000,000 (mm)
40440-40441	Parameter 3	0 - 1,000,000 (mm)
40442-40443	Parameter 4	0 - 1,000,000 (mm)
40444-40445	Parameter 5	0 - 1,000,000 (mm)

• MNU Modbus Sensor Parameters

40401 - Units

Determines the units of measure for the calculated reading when Application Type is set to 0, 1, or 7.

1 = Feet 2 = Inches 3 = Meters

40402 - Application Type

Determines the type of calculated reading performed by the sensor.

0 = Distance

1 = Depth of Level

2 = Volume of Standing Cylindrical Tank with or without Hemispherical Bottom

3 = Volume of Standing Cylindrical Tank with or without Conical Bottom

4 = Volume of Standing Rectangular Tank with or without Chute Bottom

5 = Volume of Horizontal Cylindrical Tank with or without Spherical Ends

6 = Volume of Spherical Tank

7 = Pounds (Linear Scaling)

8 = N/A

9 = Volume of Vertical Oval Tank

10 = Volume of Horizontal Oval Tank

11 = Curve Fit (Strapping Chart)

See MNU Application Parameters on pages 18 - 23 for parameter configurations for each application.

40403 - Volume Units

Determines the units of measure for the calculated reading when Application Type is set to 2 - 6 or 9 -11.

1 = Feet³

5 = Liters

2 = Million Feet³

6 = Inches³

3 = Gallons

7 = Barrels

4 = Meters³

40404 - Decimal Place

Determines the number of decimal places included in the Calculated Reading. The Calculated Reading will always be returned as a whole number.

For example, a Calculated Reading of 1126.658 (gallons, ft³, etc.) will be returned as follows:

Decimal Place = 0 Volume = 1127 (rounded to nearest whole number)

Decimal Place = 1 Volume = 11267 (divide by 10 to get true result)

Decimal Place = 2 Volume = 112666 (divide by 100 to get true result)

Decimal Place = 3 Volume = 1126658 (divide by 1000 to get true result)

40405 - Maximum Distance

Sets the distance (beginning from the Zero Point) to the point where the sensor will stop looking for target signals. Targets detected beyond the Maximum Distance value will be ignored by the sensor. Maximum Distance + Offset (Holding Register 40417) cannot exceed the sensor's maximum operating range (see Specifications, page 3).

40406 - Full Distance

Sets the distance (beginning from the Zero Point) to the point where the monitored vessel is considered full.

40407 - Empty Distance

Sets the distance (beginning from the Zero Point) to the point where the monitored vessel is considered empty.

40408 - Sensitivity

Sets the level of gain that is applied to the echo (0-100%). When operating in AutoSense, Hard-Target, or Soft-Target (see Gain Control, Holding Register 40411), Sensitivity sets an upper limit for the amplification that can be applied to the echo. If operating in Manual, this parameter sets the gain.

When using manual Gain Control, set Sensitivity to the minimum value that will allow the target to be reliably tracked through the full range of expected environmental conditions (i.e., apply only as much amplification as necessary). This reduces power usage and extends transducer life.

40409 - Pulses

Sets number ultrasonic pulses per transmission burst (0-20). The more pulses that are sent in a burst, the stronger the returning echo. For Gain Control (Holding Register 40411) settings Auto Sense, Hard Target, and Soft Target, this setting limits the maximum number of pulses used by the sensor.

When Gain Control is set to Manual, increase the strength of the transmission by increasing Pulses for detecting soft targets in damping environments. In acoustically active environments or small enclosed areas, decrease Pulses to reduce multiple echoes.

40410 - Blanking

Sets the blanking distance, which is the zone from the Zero Point of the sensor to the point from which the first echo will be accepted. While blanking distance can be used to ignore unwanted targets--such as welds, seams, pipe fittings, or gaskets--between the sensor and the closest acceptable target level, such objects generally create additional reflections and echoes, which are hard to filter out. More often, blanking distance is used for a sensor installed in a stand pipe.

 NOTE: Increases in Pulses (40409) may require increased Blanking (40410).

40411 - Gain Control

Selects the control mode governing the sensor's gain settings (Sensitivity and Pulses, Holding Registers 40408 and 40409). In general, using the lowest combined settings of Sensitivity and Pulses that allow for a high-quality return signal will consume less power and extend the life of the transducer.

In Manual, the sensor ramps up the effective sensitivity until it matches the setting in Sensitivity. No signal optimization is calculated/performed.

In Autosense, the sensor ramps the effective sensitivity and pulses until an optimal return signal (Signal Strength, Input Register 30307 lower byte) is reached. Should the return signal change, the sensor will adjust the gain settings.

In Hard-Target, the sensor ramps the effective sensitivity up slower than in Manual, since hard (or close) targets return better signals quicker. Ramping the sensitivity slower allows any initial ringing to clear before the sensor begins "listening" for return signals.

In Soft-Target, the sensor ramps the effective sensitivity up quicker than in Manual, since soft (or further away) targets take longer to return high-quality signals.

Autosense Soft-Target combines the quick-ramping and maximum settings of Soft-Target with the continuous, automatic adjustment of Autosense.

Autosense Hard-Target combines the slow-ramping and maximum settings of Hard-Target with the continuous, automatic adjustment of Autosense.

- 0 = Manual
- 1 = AutoSense
- 2 = Hard-Target
- 3 = Soft-Target
- 4 = AutoSense Soft-Target
- 5 = AutoSense Hard-Target

 NOTE: When Gain Control is set to Manual, Hard-Target, or Soft-Target, Sensitivity (40408) and Pulses (40409) settings are the maximum possible values used by the sensor.

 **NOTE:** For most applications, AutoSense, AutoSense Soft-Target, or AutoSense Hard-Target will provide the best results. Manual, Hard-Target, and Soft-Target are best used for troubleshooting.

40412 - Averaging

Sets the number of qualified received signals (0-100) to average for the displayed reading. Qualified received signals are placed in a first-in, first-out buffer, the contents of which are averaged for the displayed output. The larger the number of qualified received signals being averaged, the smoother the output reading will be, and the slower the reading will be to react to quickly changing targets.

40413 - Filter Window

Determines the physical range (0 - 15,250 mm) of qualified received signals, based on the current reading. Signals beyond the +/- Filter Window range of the current reading will not qualify unless the average moves. Signals outside the extents of the Filter Window are written to the Out of Range samples buffer (Holding Register 40414).

40414 - Out of Range

Sets the number of consecutive samples outside the Filter Window (Holding Register 40413) necessary to automatically adjust the current reading and move the Filter Window.

40415 - Sample Rate

Sets the time delay between samples taken by the sensor (10 - 1000 ms). While shorter time delays allow for quicker sensor response times to changing levels, longer sample rate delays reduce the likelihood of echo-based false positives. Also, longer sample rates result in longer sensor life.

40416 - Multiplier

Calibrates the sensor for changes in the speed of sound due to variations in atmospheres. The Multiplier is shown by the values 1 - 1999, but these values are understood to represent 0.001 - 1.999. The default of 1000 (i.e. 1.000) is used for most applications. See the Calibration section of Chapter 4.

40417 - Offset

Sets the Zero Point of the sensor, the point from which the calculated distance is measured. When the Offset is set to 0, the Zero Point of the sensor is at the face of the transducer (See Figure 3.1). A positive setting will move the Zero Point forward, in front of the sensor face (See Figure 3.2). Setting the Offset to a negative number will move the Zero Point backward, behind the sensor face (See Figure 3.3).

In all cases, Blanking (Holding Register 40410) is measured from the end of Offset, and the effective measurement zone of the sensor begins at the forward end of Blanking. If Offset is more negative than Blanking is positive, the net difference will be a loss in sensor maximum range (See Figure 3.3).

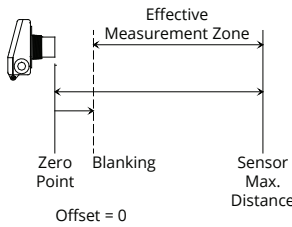

Figure 3.1

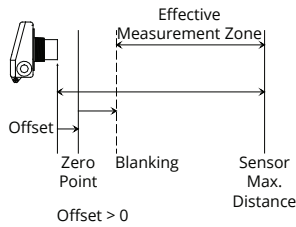

Figure 3.2

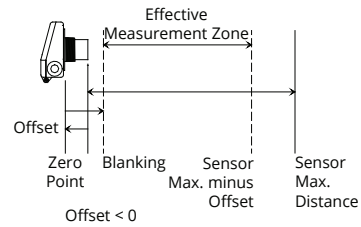

Figure 3.3

40420 - Temperature Compensation

Activates or deactivates the MNU's internal temperature compensation circuit (1 = On, 0 = Off). The speed of sound changes with changes in temperature, therefore changes in temperature can affect distance measurements. These effects can be minimized by activating temperature compensation.

- **MNU Web / Independant Modbus Alarm Parameters**

MNU sensors interfaced with an LOE web-enabled master sensor or an RST-5003 web-enabled master controller can be configured to generate website alarms via levelandflow.com. Refer to the LOE or RST-5003 user manuals (available on www.apgsensors.com/support) for more information.

MNU sensors do not have independent physical or electronic trip outputs. Via LOE or RST-5003 web-enabled devices, Holding Registers 40430 - 40435 can be configured to create outputs in Input Registers 30309 and 30310 that will trigger alarms through web interfaces. These registers can also be configured/monitored via RS-485 Modbus programming, but APG Modbus software cannot be used to generate such alerts or alarms.

40430 - Trip 1 Value

40433 - Trip 2 Value

Sets the distance (0 - 15,250 mm) to the trip position closest to the sensor face.

40431 - Trip 1 Window

40434 - Trip 2 Window

Sets the distance (0 - 15,250 mm) from the first trip position to the trip position farthest from the sensor face.

40432 - Trip 1 Type

40435 - Trip 2 Type

Sets the Trip Type for web outputs or independently-configured Modbus outputs. Trip Types are configured with two independent digits: the first for Alarm Type (1, or 2), and the second for Trip Condition (0-5, 7, or 9).

Alarm Type _____

1_ - Active Alarm

Designates the active trip point as an alarm condition. To initiate an alarm whenever the Trip Type _3 is active (on), Trip Type would be set to **13**.

Alarm Type _____

2_ - Inactive Alarm

Designates an inactive trip point as an alarm condition. To initiate an alarm whenever the Trip Type _3 is inactive (off), Trip Type would be set to **23**.

Trip Condition

_0 - Near

Near activates the trip status whenever the target surface is closer than the Trip Value setting.

Trip Condition

_1 - Exclusive

Exclusive activates the trip status whenever the target surface is closer than the Trip Value setting OR beyond the Trip Value + Trip Window setting.

Trip Condition

_2 - Hysteresis Near

Hysteresis Near activates the trip status whenever the target surface moves closer than the Trip Value setting. The trip status remains activated until the target surface moves beyond the Trip Value + Trip Window setting. The trip status remains off until the target surface moves closer than the Trip Value setting again.

Trip Condition

_3 - Far

Far activates the trip status whenever the target surface is beyond the Trip Value setting.

Trip Condition

_4 - Inclusive

Inclusive activates the trip status whenever the target surface is beyond the Trip Value setting AND closer the Trip Value + Trip Window setting.

Trip Condition

_5 - Hysteresis Far

Hysteresis Far activates the trip status whenever the target surface moves beyond the Trip Value + Trip Window setting. The trip status remains activated until the target surface moves closer than the Trip Value setting. The trip status remains off until the target surface moves beyond the Trip Value + Trip Window setting again.

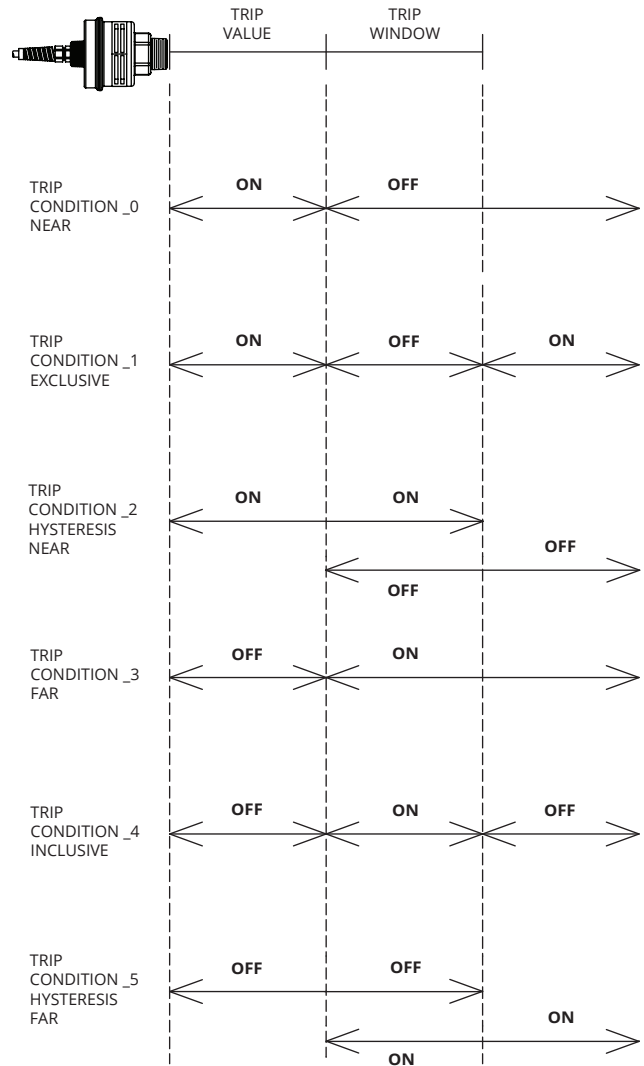

Trip Condition

_6 - N/A

Trip Condition

_7 - *Loss of Echo*

Loss of Echo activates the trip status whenever no target is detected within the Maximum Distance (Holding Register 40405).

Trip Condition

_8 - N/A

Trip Condition

_9 - *Rate of Change*

Rate of Change activates the trip status whenever a user-defined maximum rate of level change (change in distance or level divided by elapsed time) is exceeded. Trip Value (Holding Register 40430 or 40433) defines the distance and Trip Window (Holding Register 40431 or 40434) defines the time.

• **Configuring MNU Modbus Application Parameters**

Each MNU application (Holding Register 40402) uses a specific configuration of certain Holding Registers. Below are the configurations of registers used by each application. Images defining tank dimensions assume sensor placement at the top of or above tank.

Application 0 - Distance

<u>Register</u>	<u>Function</u>	<u>Value Range</u>
40400	Device Address	1 to 247
40401	Units	1 = Feet, 2 = Inches, 3 = Meters
40402	Application Type	0
40403	Volume Units	--
40404	Decimal (Calculated)	0 - 3
40405	Max Distance	0 - 15,250 mm

Application 1 - Depth of Level

<u>Register</u>	<u>Function</u>	<u>Value Range</u>
40400	Device Address	1 to 247
40401	Units	1 = Feet, 2 = Inches, 3 = Meters
40402	Application Type	1
40403	Volume Units	--
40404	Decimal (Calculated)	0 - 3
40405	Max Distance	Less than Empty Distance
40406	Full Distance	Typically = Blanking Distance
40407	Empty Distance	0 - 15,250 mm

Application 2 - Volume of Standing Cylindrical Tank ± Hemispherical Bottom

<u>Register</u>	<u>Function</u>	<u>Value Range</u>
40400	Device Address	1 to 247
40401	Units	--
40402	Application Type	2
40403	Volume Units	1 - 7
40404	Decimal (Calculated)	0 - 3
40405	Max Distance	Less than Empty Dist.
40406	Full Distance	Typ. = Blanking Dist.
40407	Empty Distance	0 - 15,250 mm
40436-40437	Tank Diameter	0 - 1,000,000 (mm)
40438-40439	Radius of Bottom Hemisphere	0 - 1,000,000 (mm)

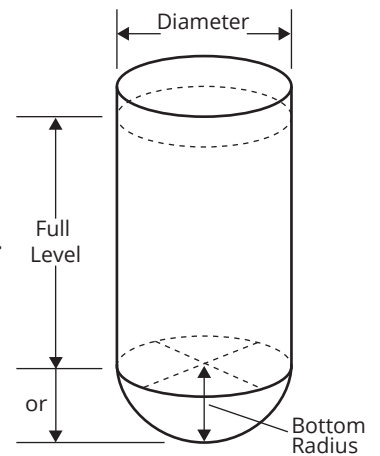

Application 3 - Volume of Standing Cylindrical Tank ± Conical Bottom

<u>Register</u>	<u>Function</u>	<u>Value Range</u>
40400	Device Address	1 to 247
40401	Units	--
40402	Application Type	3
40403	Volume Units	1 - 7
40404	Decimal (Calculated)	0 - 3
40405	Max Distance	Less than Empty Dist.
40406	Full Distance	Typ. = Blanking Dist.
40407	Empty Distance	0 - 15,250 mm
40436-40437	Tank Diameter	0 - 1,000,000 (mm)
40438-40439	Cone Diameter (at bottom of cone)	0 - 1,000,000 (mm)
40440-40441	Length (height) of Cone	0 - 1,000,000 (mm)

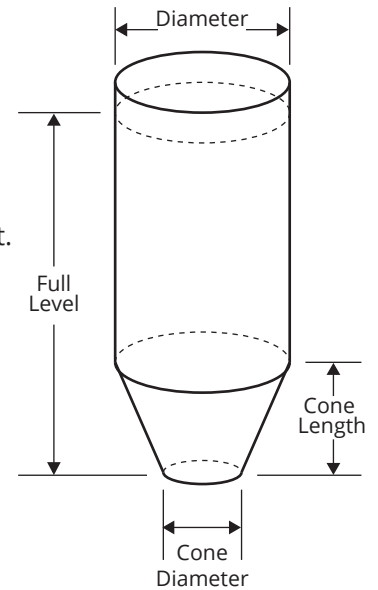

Application 4 - Volume of Standing Rectangular Tank ± Chute Bottom

<u>Register</u>	<u>Function</u>	<u>Value Range</u>
40400	Device Address	1 to 247
40401	Units	--
40402	Application Type	4
40403	Volume Units	1 - 7
40404	Decimal (Calculated)	0 - 3
40405	Max Distance	Less than Empty Dist.
40406	Full Distance	Typ. = Blanking Dist.
40407	Empty Distance	0 - 15,250 mm
40436-40437	Tank X Dimension	0 - 1,000,000 (mm)
40438-40439	Tank Y Dimension	0 - 1,000,000 (mm)
40440-40441	Chute X Dimension	0 - 1,000,000 (mm)
40442-40443	Chute Y Dimension	0 - 1,000,000 (mm)
40444-40445	Length (height) of Chute	0 - 1,000,000 (mm)

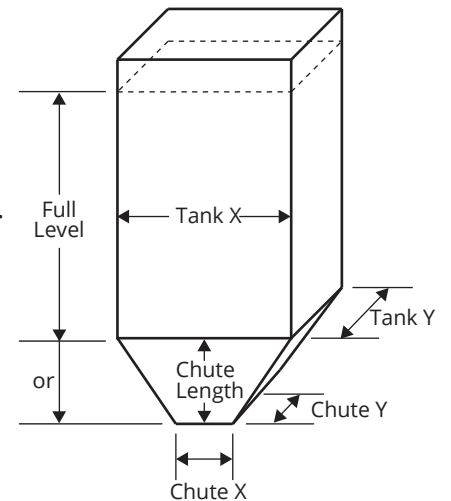

Application 5 - Volume of Horizontal Cylindrical Tank ± Hemispherical Ends

<u>Register</u>	<u>Function</u>	<u>Value Range</u>
40400	Device Address	1 to 247
40401	Units	--
40402	Application Type	5
40403	Volume Units	1 - 7
40404	Decimal (Calculated)	0 - 3
40405	Max Distance	Less than Empty Dist.
40406	Full Distance	Typ. = Blanking Dist.
40407	Empty Distance	0 - 15,250 mm
40436-40437	Tank Length	0 - 1,000,000 (mm)
40438-40439	Tank Diameter	0 - 1,000,000 (mm)
40440-40441	Radius of End Hemispheres	0 - 1,000,000 (mm)

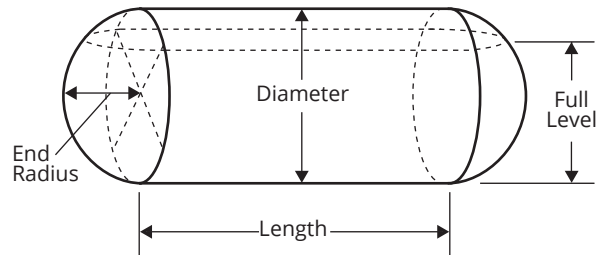

Application 6 - Volume of Spherical Tank

<u>Register</u>	<u>Function</u>	<u>Value Range</u>
40400	Device Address	1 to 247
40401	Units	--
40402	Application Type	6
40403	Volume Units	1 - 7
40404	Decimal (Calculated)	0 - 3
40405	Max Distance	Less than Empty Dist.
40406	Full Distance	Typ. = Blanking Dist.
40407	Empty Distance	0 - 15,250 mm
40436-40437	Tank Diameter	0 - 1,000,000 (mm)

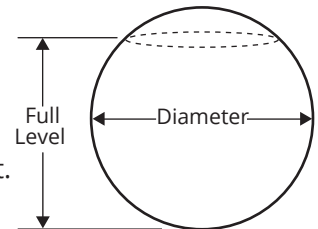

Application 7 - Pounds (Linear Scaling)

<u>Register</u>	<u>Function</u>	<u>Value Range</u>
40400	Device Address	1 to 247
40401	Units	1 = Feet, 2 = Inches, 3 = Meters
40402	Application Type	7
40403	Volume Units	--
40404	Decimal (Calculated)	0 - 3
40405	Max Distance	Less than Empty Dist.
40406	Full Distance	Typ. = Blanking Dist.
40407	Empty Distance	0 - 15,250 mm
40436-40437	Multiplier (linear scalar)	0 - 1,000,000 (1000 = 1.000)

Application 9 - Volume of Vertical Oval Tank

<u>Register</u>	<u>Function</u>	<u>Value Range</u>
40400	Device Address	1 to 247
40401	Units	--
40402	Application Type	9
40403	Volume Units	1 - 7
40404	Decimal (Calculated)	0 - 3
40405	Max Distance	Less than Empty Dist.
40406	Full Distance	Typ. = Blanking Dist.
40407	Empty Distance	0 - 15,250 mm
40436-40437	Tank Length	0 - 1,000,000 (mm)
40438-40439	Tank Depth	0 - 1,000,000 (mm)
40440-40441	Tank Width	0 - 1,000,000 (mm)

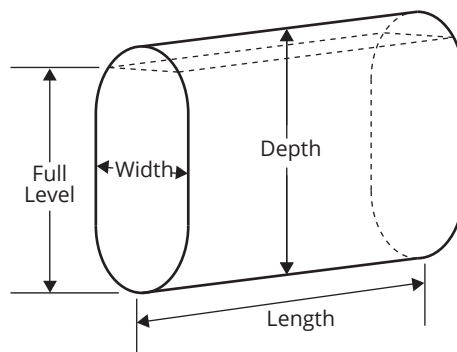

Application 10 - Volume of Horizontal Oval Tank

<u>Register</u>	<u>Function</u>	<u>Value Range</u>
40400	Device Address	1 to 247
40401	Units	--
40402	Application Type	10
40403	Volume Units	1 - 7
40404	Decimal (Calculated)	0 - 3
40405	Max Distance	Less than Empty Dist.
40406	Full Distance	Typ. = Blanking Dist.
40407	Empty Distance	0 - 15,250 mm
40436-40437	Tank Length	0 - 1,000,000 (mm)
40438-40439	Tank Depth	0 - 1,000,000 (mm)
40440-40441	Tank Width	0 - 1,000,000 (mm)

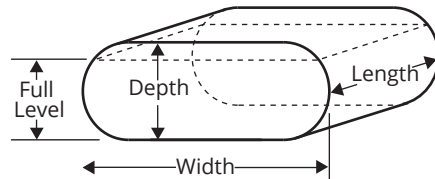

Application 11 - Strapping Chart (Curve Fit Polynomial Values)

<u>Register</u>	<u>Function</u>	<u>Value Range</u>
40400	Device Address	1 to 247
40401	Units	1 = Feet, 2 = Inches, 3 = Meters
40402	Application Type	11
40403	Volume Units	1 - 7
40404	Decimal (Calculated)	0 - 3
40405	Max Distance	Less than Empty Dist.
40406	Full Distance	Typ. = Blanking Dist.
40407	Empty Distance	0 - 15,250 mm
40436-40437	X ³ Coefficient	0 - 1,000,000
40438-40439	X ² Coefficient	0 - 1,000,000
40440-40441	X ¹ Coefficient	0 - 1,000,000
40442-40443	X ⁰ Coefficient	0 - 1,000,000

 **NOTE:** The Coefficient values must be calculated in the Units selected. The Coefficients will not adjust if Units is changed after they are set.

Chapter 4: Maintenance

• General Care

Your MNU ultrasonic sensor is very low maintenance and will need little care as long as it was installed correctly. However, in general, you should:

- Avoid applications for which the sensor was not designed, such as extreme temperatures, contact with incompatible corrosive chemicals and fumes, or other damaging environments.
- Inspect the threads whenever you remove the sensor from duty or change its location.

• Troubleshooting

Should you have problems with your MNU, here are some troubleshooting steps.

- If your MNU sensor is not communicating with your control system/Modbus Network, try reversing the A & B wires from the sensor into your system.
- Check the received signal strength (Input Register 307). If the signal strength is low, alternately increase Pulses and Sensitivity (Holding Registers 40409 and 40408) until the signal strength improves.
- Ensure Temperature Compensation (Holding Register 40420) is On (set to 1).
- Set the Gain Control to AutoSense (Holding Register 40411).
- Ensure that Blanking (Holding Register 40410) is accurately set to account for any unwanted targets between the sensor and the closest acceptable target.

• Loss of Echo

When the sensor can no longer detect returning sound waves--called Loss of Echo--the output will match empty tank conditions.

- For Application Type 0 (Holding Register 40402), Distance Mode, the output will match the Max Distance Value (Holding Register 40405).
- For all Level/Volume Application Types 1 - 11, the output will go to 0.

• Calibration

This procedure uses targets at known distances to calibrate the sensor's accuracy. A wall or other large, flat object is recommended for the long range target.

- Point the sensor at a target at a known distance near the maximum range of the sensor, 25' for a single solid object (See Figure 4.1).
- Adjust the Multiplier value until the distance reading on the sensor matches the actual measured distance to the target (Holding Register 40416).
- Point the sensor at a target near the minimum measurement range, 1' plus any Blanking distance (See Figure 4.2).
- Adjust the Offset value until the distance reading on the sensor matches the actual measured distance to the target (Holding Register 40417).
- Repeat previous two steps until no further adjustment is required.



Figure 4.1

Figure 4.2

• Repair and Returns

Should your MNU ultrasonic sensor require service, please contact the factory via phone, email, or online chat. We will issue you a Return Material Authorization (RMA) number with instructions.

- Phone: 888-525-7300
- Email: sales@apgsensors.com
- Online chat at www.apgsensors.com

Please have your MNU sensor's part number and serial number available. See Warranty and Warranty Restrictions for more information.



Automation Products Group, Inc.

Tel: 1/888/525-7300 • Fax: 1/435/753-7490 • www.apgsensors.com • sales@apgsensors.com