

# **Hammer Union Pressure Transmitter User Manual**

For The HU-L24 & HU-L27

# Table of Contents

<b>Introduction .....</b>	<b>iii</b>
<b>Warranty and Warranty Restrictions .....</b>	<b>iv</b>
<b>Chapter 1: Specifications and Options.....</b>	<b>1</b>
Dimensions .....	1
Specifications .....	1
Model Number Configurator.....	2
Electrical Connectors and Pinout Table .....	3
<b>Chapter 2: Installation and Removal Procedures and Notes.....</b>	<b>4</b>
Tools Needed.....	4
Physical Installation .....	4
Electrical Installation .....	4
Shunt Calibration Procedures.....	5
Removal Instructions .....	5
<b>Chapter 3: Maintenance .....</b>	<b>6</b>
General Care .....	6
Repair and Returns.....	6
<b>Chapter 4: Hazardous Location Installation and Certification .....</b>	<b>7</b>
Intrinsically Safe Wiring Diagram .....	7
CSA Certificate of Compliance .....	8-11
EC Declaration of Conformity .....	12

# Introduction

Thank you for purchasing a Hammer Union Pressure Transmitter from APG. We appreciate your business! Please take a few minutes to familiarize yourself with your Hammer Union and this manual.

APG's Hammer Union Pressure Transmitter is extremely rugged and designed for the environments of land-based and offshore drilling installations. It is designed specifically for use with the 1502 and 2202 Hammer Wing Union. These units are constructed from materials designed for service with highly abrasive and corrosive media and comply with new NACE standards.

## Reading your label

Every APG instrument comes with a label that includes the instrument's model number, part number, serial number, and a wiring pinout table. Please ensure that the part number and pinout table on your label match your order. The following electrical ratings and approvals are also listed on the label. Please refer to the Certificate of Compliance and Declaration of Conformity at the back of this manual for further details.

## Electrical ratings



Input: 10 to 28 VDC; Output: 4-20 mA / 0-5 VDC (per order)

Class I, Division 1, Groups C, D

Class I, Zone 0

Ex ia IIB T4: -40°C to 85°C; Enclosure Type IP67

AEx ia IIB T4: -40°C to 85°C; Enclosure Type IP67

$V_{max} U_i = 28VDC$ ,  $I_{max} I_i = 110mA$ ,  $P_{max} P_i = 1W$ ,  $C_i = 60.89nF$ ,  $L_i = 7.7mH$

## The following approvals only apply to the L24 (4-20mA) version

ATEX Directive: 0344

Sira 13ATEX2023



II 1G Ex ia IIB T4 Ga

Ta: -40°C to 85°C

$U_i \leq 28 V$ ,  $I_i \leq 110 mA$ ,  $P_i \leq 1 W$ ,  $C_i \leq 60.89 nF$ ,  $L_i \leq 7.7 mH$

IECEX CSA 13.0004  
Ex ia IIB T4 Ga

**i** IMPORTANT: Hammer Union Pressure Transmitter MUST be installed according to drawing 9002460 (Intrinsically Safe Wiring Diagram) on page 7 to meet listed approvals. Faulty installation will invalidate all safety approvals and ratings.

## Warranty and Warranty Restrictions

This product is covered by APG's warranty to be free from defects in material and workmanship under normal use and service of the product for 24 months. For a full explanation of our Warranty, please visit <https://www.apgsensors.com/about-us/terms-conditions>. Contact Technical Support to receive a Return Material Authorization before shipping your product back.

Scan the QR code below to read the full explanation of our Warranty on your tablet or smartphone.



# Chapter 1: Specifications and Options

## • Dimensions

### Hammer Union with 1502 Fitting

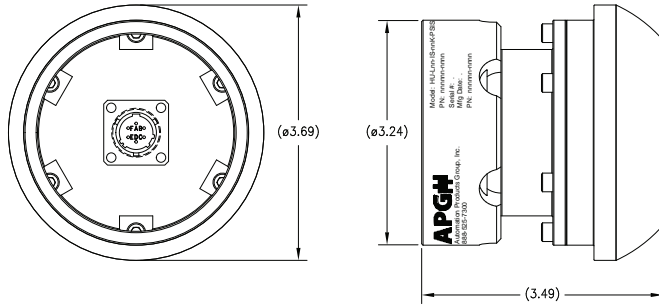

### Hammer Union with 2002, 2202 Fitting

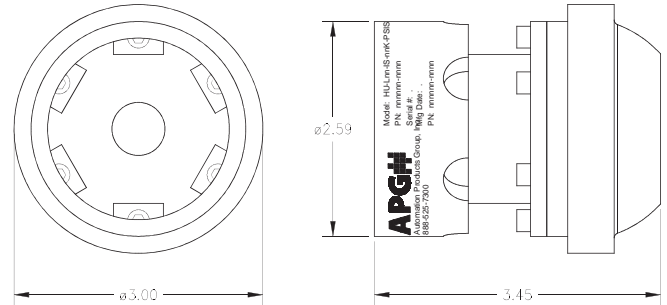

## • Specifications

### Performance

Pressure Ranges  
Analog Output  
Over Pressure

Burst Pressure

Life

0 to 20K PSIS (Per Part Number)

4-20mA, 0-5VDC

1.5X Full Scale, 22.5 kpsi, or limit of WESCO fitting, whichever is smallest

3.0X Full Scale, 22.5 kpsi, or limit of WESCO fitting, whichever is smallest

10 million cycles, minimum

### Accuracy

Linearity, Hysteresis & Repeatability  
Thermal Zero Shift  
Thermal Span Shift

±0.25% of Full Scale (BFSL)

±0.026% FSO/°C (±0.01% FSO/°F)

±0.026% FSO/°C (±0.01% FSO/°F)

### Environmental

Operating Temperature  
Compensated Temperature  
Enclosure Protection

-40 to 85°C (-40 to 185°F)

-40 to 65°C (-40 to 150°F)

IP67/IP65

### Electrical

Supply Voltage  
Output Signal @ 21°C

10-28 VDC on sensor

4-20 mA: 3-30 mA max.

0 to 5 VDC: 7mA max

### Materials of Construction

Wetted Materials  
Enclosure

Incoloy 925 NACE MR-01-75 and ISO 15156-3

316L Stainless Steel

### Mechanical

Pressure Connection  
Weight

WECO® standard 1502, 2002, 2202 or equivalent

2.3kg (5.10 lbs)

## • Model Number Configurator

Part Number: HU -      - IS -      - PSIS -      -      -       
                                  A                                  B                                  C                                  D                                  E

### A. Output

- L24**            4-20 mA
- L27**            0-5 VDC

### B. Pressure Range

- 5K**             0 - 5,000 psis
- 6K**             0 - 6,000 psis
- 10K**            0 - 10,000 psis
- 15K**            0 - 15,000 psis
- 20K**            0 - 20,000 psis (2002 fitting only)

### C. Electrical Connection

#### 4-20 mA Output Options

- E1**             4 pin M12 (w/ Shunt Cal)
- E2**             5 pin M12 (w/ Shunt Cal)
- E6**             3 pin Turck M12 [RSFVL36]
- E7**             4 pin Reverse Bayonet (w/ Shunt Cal)
- E8**             5 pin Threaded MS3102 (w/ Shunt Cal)
- E9**             3 pin Threaded MS3102
- E11**            4 pin Threaded MS3102
- E13**            7 pin Jupiter/Souriau (w/ Shunt Cal)
- E15**            6 pin Bayonet (w/ switched Shunt Cal)
- E18**            4 pin Rota (w/ Shunt Cal)
- E20**            4 pin Turck M12 [P-RSFV 40-0.3]
- E28**            6 pin Bayonet
- E40**            3 pin Bayonet (w/ Shunt Cal)
- E45**            6 pin Bayonet (w/ Shunt Cal)

#### 0-5 VDC Output Options

- E3**             4 pin Threaded MS3102
- E14**            6 pin Bayonet (w/ switched Shunt Cal)

#### 4-20 mA Direct Wiring Options w/ Shunt Cal

- E5**             1/2 NPT coupling, flying leads
- E10**            Junction Box (1502 fitting only)
- E17**            1/2 NPT coupling, 10' cable, flying leads

### D. Fitting

- P34**            Large HU 1502 Weco fitting
- P35**            Small HU 2002 / 2202 Weco fitting
- P36**            Large Welded HU 1502 Weco fitting
- P37**            Small Welded HU 2002 / 2202 Weco fitting

### E. Enclosure

- K0**            No options (standard)
- K7**            With handle\*
- K1**            With protective cage assembly\*

\*Consult factory

# • Electrical Connectors and Pinout Table

Face view of male connector on HU

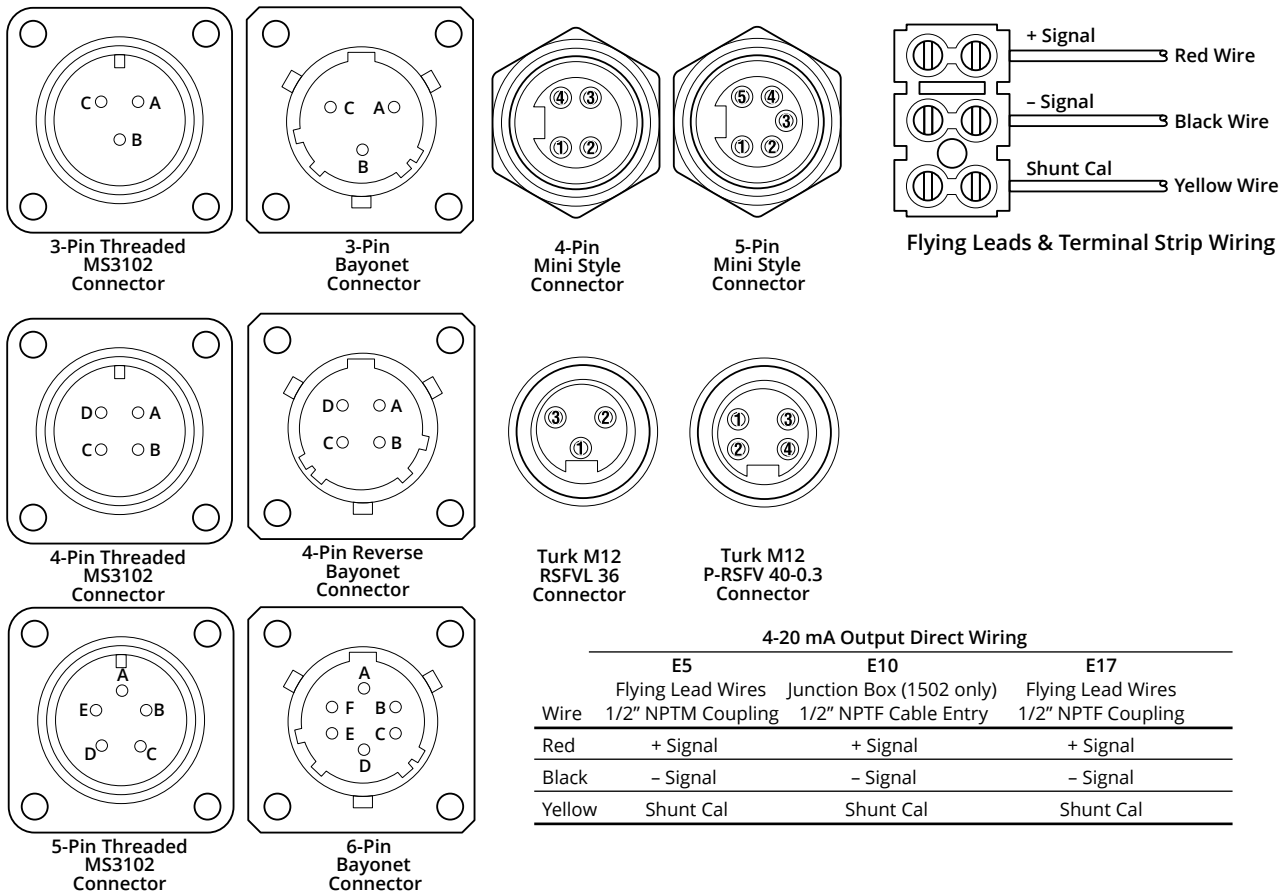

Wire	4-20 mA Output Direct Wiring		
	E5 Flying Lead Wires 1/2" NPTM Coupling	E10 Junction Box (1502 only) 1/2" NPTF Cable Entry	E17 Flying Lead Wires 1/2" NPTF Coupling
Red	+ Signal	+ Signal	+ Signal
Black	- Signal	- Signal	- Signal
Yellow	Shunt Cal	Shunt Cal	Shunt Cal

Pin	0 to 5 VDC Output			4-20 mA Output				
	E3 4 pin MS3102 Electroplate Nickel	E14 6 pin Bayonet Stainless Steel	E1 4 pin Mini Nickel Plated Zinc	E2 5 pin Mini Nickel Plated Zinc	E6 3 pin M12 Stainless Steel	E7 4 pin Bayonet Stainless Steel	E8 5 pin MS3102 Stainless Steel	E9 3 pin MS3102 Stainless Steel
A (1)	+ Power	+ Power	+ Signal	+ Signal	No Connection	+ Power/Signal	No Connection	No Connection
B (2)	- Power	+ Signal	- Signal	- Signal	+ Power/Signal	- Power/Signal	- Power/Signal	+ Power/Signal
C (3)	+ Signal	-Power	Shunt Cal	No Connection	- Power/Signal	Shunt Cal	+ Power/Signal	- Power/Signal
D (4)	- Signal	- Signal	No connection	Shunt Cal	-	No Connection	Shunt Cal	-
E (5)	-	+Shunt Cal	-	No Connection	-	-	No Connection	-
F	-	-Shunt Cal	-	-	-	-	-	-

Note: Mating connectors sold separately.

Pin	4-20 mA Output							
	E11 4 pin MS3102 Stainless Steel	E13 7 Pin Jup./Souriau Stainless Steel	E15 6 pin Bayonet Stainless Steel	E18 4 pin ROTA Stainless Steel	E20 4 pin M12 Stainless Steel	E28 6 pin Bayonet Stainless Steel	E40 3 pin Bayonet Stainless Steel	E45 6 pin Bayonet Stainless Steel
A (1)	No Connection	+ Power/Signal	+ Power/Signal	+ Power/Signal	-Power/Signal	+ Power/Signal	+ Power/Signal	+ Power/Signal
B (2)	- Power/Signal	- Power/Signal	- Power/Signal	- Power/Signal	+ Power/Signal	- Power/Signal	- Power/Signal	- Power/Signal
C (3)	+ Power/Signal	No Connection	No Connection	Case Ground	No Connection	No Connection	Shunt Cal	No Connection
D (4)	Case Ground	No Connection	Case Ground	Shunt Cal	Case Ground	No Connection	-	Case Ground
E (5)	-	Shunt Cal	+ Shunt Cal	-	-	No Connection	-	Shunt Cal
F (6)	-	No Connection	- Shunt Cal	-	-	No Connection	-	No Connection
G (7)	-	No Connection	-	-	-	-	-	-

Note: Mating connectors sold separately.

## Chapter 2: Installation and Removal Procedures and Notes

### • Tools Needed

You will need the following tools to install your 1502 or 2002 / 2202 Hammer Union Pressure Transmitter:

- A hammer
- 1502 or 2002 / 2202 wing nut

 **DANGER:** Mismatched unions and nuts can result in dangerous or hazardous equipment failures. Always check identifications on both union pieces and nuts prior to installation. Only use pieces with matching union figure numbers, sizes, and pressure ratings.

### • Physical Installation

- Ensure mating union faces are clean, dry, and free of debris.
- Mate your Hammer Union Pressure Transmitter onto the socket.
- Place the wing nut on the Transmitter and spin into place.
- Hammer the wing nut until tight.

### • Electrical Installation

- Check the pinout table on your Hammer Union Pressure Transmitter against your order.
- Check that your electrical system wiring matches the pinout table on your Hammer Union.
- For instruments with connectors, make the connection. Otherwise, attach your wire to the provided terminal strip.



## • **Shunt Calibration Procedures**

APG's Hammer Union Pressure Transmitters can be configured with either a single-pin shunt calibration or two-pin switched shunt calibration.

### **Single-Pin Shunt Calibration Procedure**

APG's Hammer Union Pressure Transmitters with single-pin shunt cal provide a full scale output (20.0 mA or 5 VDC) when 10 to 28 VDC is applied to the designated Shunt Cal pin. See the pinout chart on your Hammer Union Pressure Transmitter's label.

- Check the pinout table on your Hammer Union Pressure Transmitter.
- For 0 - 5 VDC Hammer Unions, connect +/- Power and +/- Signal, with a volt meter connected across +/- Signal.
- For 4-20 mA Hammer Unions, connect +/- Signal, with - Signal connected through an Ammeter.
- Apply 10 to 28 VDC to the Shunt Cal pin.
- If the instrument electronics are operating properly, the output signal will go to full scale (5 VDC or 20 mA).

### **Two-Pin Shunt Calibration Procedure**

APG's Hammer Union Pressure Transmitters with two-pin shunt cal provide a full scale output (20.0 mA or 5 VDC) when + Shunt is shunted to - Shunt. This is usually accomplished via an external switch. See the pinout chart on your Hammer Union Pressure Transmitter's label.

- Check the pinout table on your Hammer Union Pressure Transmitter.
- For 0 - 5 VDC Hammer Unions, connect +/- Power and +/- Signal, with a volt meter connected across +/- Signal, and an open switch between + Shunt Cal and - Shunt Cal.
- For 4-20 mA Hammer Unions, connect +/- Signal, with - Signal connected through an Ammeter, and an open switch between + Shunt Cal and - Shunt Cal.
- Close the open switch between + Shunt Cal and - Shunt Cal, effectively applying power to - Shunt Cal. (+ Power for 0 - 5 VDC, and + Signal for 4 - 20 mA, is tied to + Shunt Cal inside the Hammer Union)
- If the instrument electronics are operating properly, the output signal will go to full scale (5 VDC or 20 mA) when the switch is closed.

## • **Removal Instructions**

Removing your Hammer Union Pressure Transmitter from service must be done with care. It's easy to create an unsafe situation if you are not careful to follow these guidelines:

- Make sure the pressure is completely removed from the line where your sensor is installed. Follow any and all procedures for safely isolating any media contained inside the line or vessel.
- Remove the Hammer Union wing nut.
- Remove your Pressure Transmitter.
- Clean the sensor's fitting and diaphragm of any debris (see above instructions) and inspect for damage.
- Store your sensor in a dry place, at a temperature between -40° F and 180° F.

 **DANGER:** Removing your Hammer Union Pressure Transmitter while there is still pressure in the line could result in injury or death.

## Chapter 3: Maintenance

### • General Care

Your Hammer Union Pressure Transmitter is designed to be maintenance free. As such, there are no customer servicable parts on or in the device. However, in general, you should:

- Avoid touching the diaphragm. Contact with the diaphragm, especially with a tool, could permanently shift the output and ruin accuracy.
- Clean the diaphragm or the diaphragm bore only with extreme care. If using a tool is required, make sure it does not touch the diaphragm.

### • Repair and Returns

Should your Hammer Union Pressure Transmitter require service, please contact the factory via phone, email, or online chat. We will issue you a Return Material Authorization (RMA) number with instructions.

- Phone: 888-525-7300
- Email: [sales@apgsensors.com](mailto:sales@apgsensors.com)
- Online chat at [www.apgsensors.com](http://www.apgsensors.com)

Please have your Hammer Union Pressure Transmitter's part number and serial number available. See Warranty and Warranty Restrictions for more information.

 **IMPORTANT:** All repairs and adjustments of the Hammer Union Pressure Transmitter must be made by the factory. Modifying, disassembling, or altering the Hammer Union Pressure Transmitter on site is strictly prohibited.

# Chapter 4: Hazardous Location Installation and Certification

## Intrinsically Safe Wiring Diagram

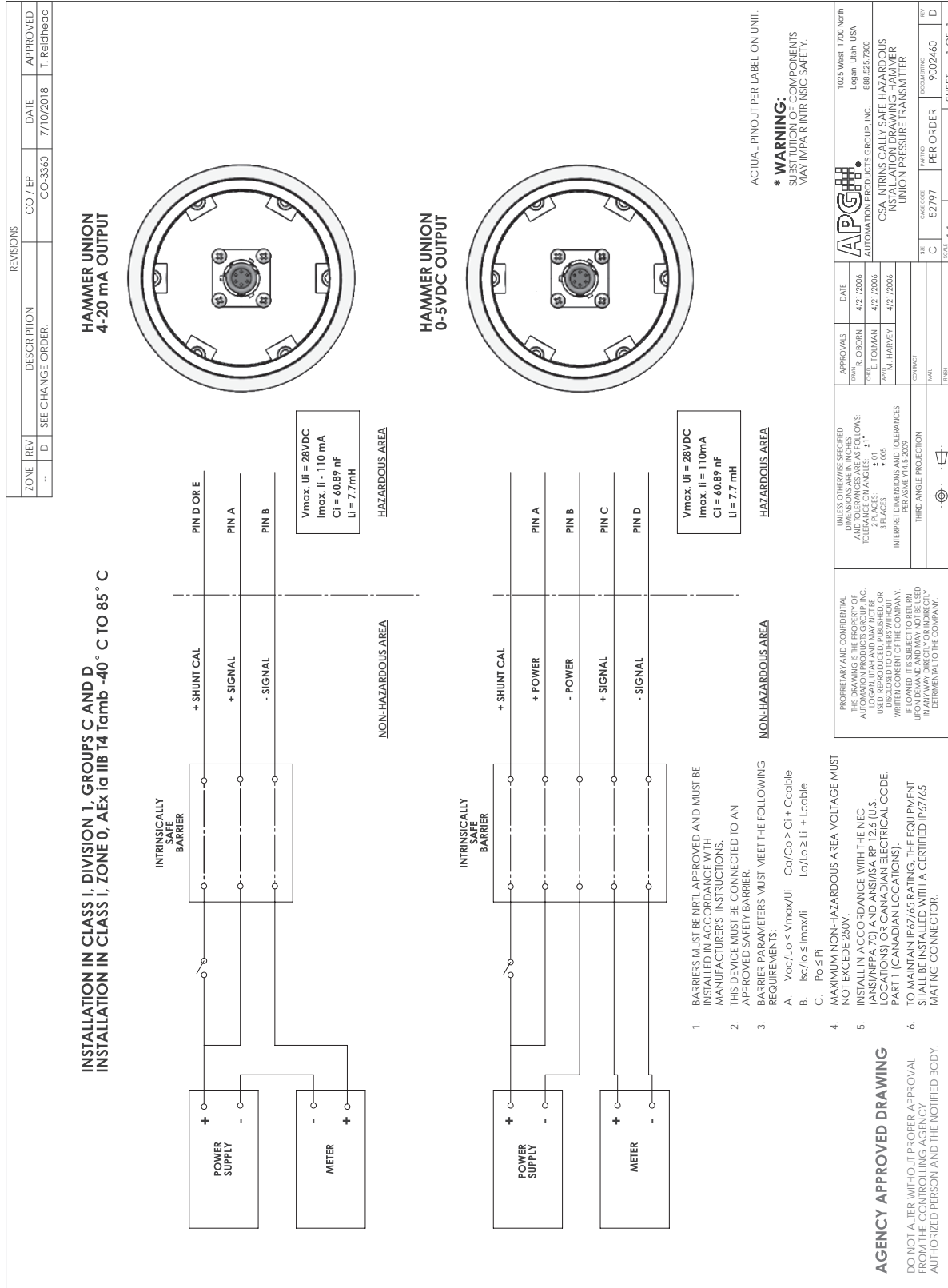

THE CASE CODE	PER PART NO	PER ORDER	PER ORDER	REV
C	52797	9002460	9002460	D

**APG**

AUTOMATION PRODUCTS GROUP, INC.

1025 West 1700 North  
Logan, Utah, USA  
888-525-7300

CSA INTRINSICALLY SAFE HAZARDOUS  
INSTALLATION DRAWING HAMMER  
UNION PRESSURE TRANSMITTER

SCALE: 1:1    DO NOT SCALE DRAWING    SHEET 1 OF 1

DATE	DATE	DATE	DATE	APPROVED
4/21/2006	4/21/2006	4/21/2006	7/10/2018	T. Reidhead

• **CSA Certificate of Compliance**



# Certificate of Compliance

**Certificate:** 1916494                                      **Master Contract:** 237484 (237484)  
**Project:** 70177689                                      **Date Issued:** 2018-06-26  
**Issued to:** Automation Products Group Inc  
1025 West 1700 North  
Logan, Utah 84321  
USA  
**Attention:** Joseph James

*The products listed below are eligible to bear the CSA Mark shown with adjacent indicators 'C' and 'US' for Canada and US or with adjacent indicator 'US' for US only or without either indicator for Canada only.*



**Issued by:** *Albert Jansen*  
Albert Jansen

## PRODUCTS

**CLASS 2258 04** - PROCESS CONTROL EQUIPMENT - Intrinsically Safe, Entity - For Hazardous Locations  
**CLASS 2258 84** - PROCESS CONTROL EQUIPMENT - Intrinsically Safe, Entity - For Hazardous Locations - To U.S. Requirements

**Class I, Division 1, Groups C, D**  
**Class I, Zone 0**  
**Ex ia IIB T4**  
**AEx ia IIB T4**

- Hammer Union Pressure Sensor, Model HU-Ln-IS, HU-1502SS-Ln, and HU1502I-Ln (where Ln = L1, L3, L24 or L27). Temperature Code Rating T4; Ambient range -40°C to +85°C; Enclosure Type: IP65 and IP67; Maximum Working Pressure: 20,000 PSI; Installed as per Drawing 9002460; Intrinsically Safe with the following Entity Parameters:

V<sub>max</sub>, U<sub>i</sub> = 28Vdc  
I<sub>max</sub>, I<sub>i</sub> = 110mA  
P<sub>max</sub>, P<sub>i</sub> = 1W  
C<sub>i</sub> = 60.89nF  
L<sub>i</sub> = 7.7mH



**Certificate:** 1916494  
**Project:** 70177689

**Master Contract:** 237484  
**Date Issued:** 2018-06-26

**Conditions of Acceptability**

- To maintain IP67/65 rating, the equipment shall be installed with a certified IP67/65 mating connector.
- This device must be connected to a NRTL approved safety barrier

Note: Suffixes are added to indicate options not affecting safety.

**APPLICABLE REQUIREMENTS**

CAN/CSA-C22.2 No. 0-10 (R2015)	General Requirements – Canadian Electrical Code, Part II
CAN/CSA-C22.2 No. 60950-1-07	Information technology Equipment – Safety – Part1: General Requirements
CAN/CSA-C22.2 No. 60079-0:15	Explosive Atmospheres - Part 0: Equipment - General requirements
CAN/CSA-C22.2 No. 60079-11:14	Explosive Atmospheres – Part 11: Equipment protection by intrinsic safety "i"
UL 60950-1 Edition 2	Information technology Equipment – Safety – Part1: General Requirements
ANSI/UL 60079-0:13	Electrical Apparatus for Explosive Gas Atmospheres - Part 0: General Requirements
ANSI/UL 60079-11:13	Electrical apparatus for Explosive Gas Atmospheres - Part 11: Intrinsic Safety "i"



**Certificate:** 1916494  
**Project:** 70177689

**Master Contract:** 237484  
**Date Issued:** 2018-06-26

## MARKINGS

The manufacturer is required to apply the following markings:

- Products shall be marked with the markings specified by the particular product standard.
- Products certified for Canada shall have all Caution and Warning markings in both English and French.

Additional bilingual markings not covered by the product standard(s) may be required by the Authorities Having Jurisdiction. It is the responsibility of the manufacturer to provide and apply these additional markings, where applicable, in accordance with the requirements of those authorities.

The products listed are eligible to bear the CSA Mark shown with adjacent indicators 'C' and 'US' for Canada and US (indicating that products have been manufactured to the requirements of both Canadian and U.S. Standards) or with adjacent indicator 'US' for US only or without either indicator for Canada only.

- (1) Submitter's name, trademark, or the CSA file number (adjacent the CSA Mark).
- (2) Catalogue / Model designation.
- (3) Entity Parameters
- (4) Date code / Serial number traceable to month and year of manufacture.
- (5) Hazardous Location designations.
- (6) The words "Exia, INTRINSICALLY SAFE".
- (7) Temperature code T4.
- (8) Ambient -40°C to +85°C
- (9) Maximum working pressure.
- (10) Enclosure Type: IP 65/67
- (11) The CSA Mark with the c and us qualifiers as applicable.

The products listed above are eligible to bear the CSA Mark with adjacent indicators "C" and "US" for Canada and US or with adjacent indicator "US" for US only or without either indicator for Canada only.



**Certificate:** 1916494  
**Project:** 70177689

**Master Contract:** 237484  
**Date Issued:** 2018-06-26

### *Supplement to Certificate of Compliance*

**Certificate:** 1916494

**Master Contract:** 237484 (237484)

*The products listed, including the latest revision described below,  
are eligible to be marked in accordance with the referenced Certificate.*

### **Product Certification History**

<b>Project</b>	<b>Date</b>	<b>Description</b>
70177689	2018-06-26	Update CSA Report 1916494 to add two new housing designs, specified as HU-1502I and HU-1502SS. Upgrade all models from CSA 142-M1987 to UL/CSA 61010-1.
2703264	2014-09-15	Update to Report 1916494 to revise input filter board.
2615564	2013-04-02	Update to include revised drawings with minor changes.
2517307	2012-08-09	Update to include a new EMI board within the Hammer Union Pressure Sensor as well an IP65/67 certification for the sensor enclosure.
1916494	2007-05-30	Supersedes report 1854327 (sub report 1726089) to change listing to show Ex ia and AEx ia.

• **EC Declaration of Conformity**

**EU** *Declaration of Conformity*



**Manufacturer's Name:** Automation Products Group Inc.

**Address:** 1025 West 1700 North  
Logan, UT 84321

Tel: (435) 753-7300

Fax: (435) 753-7490

Email: [sales@apgsensors.com](mailto:sales@apgsensors.com)

Web: [www.apgsensors.com](http://www.apgsensors.com)

*Declares that the product:*

**Product Name:** HU-L24-IS-nnK-PSIS-Enn-Pnn-Knn-Bnn, HU1502I, and  
HU1502SS Pressure Transmitter

*Conforms to:*

**ATEX Directive 2014/34/EU**

**- EC Type Examination Certificate:** Sira 13ATEX2023X

Sira 0518

Sira Certification Service, Rake Lane, Eccleston, Chester, CH4 9JN, England

**Description of Equipment or Protective System:**

The equipment measures a pressure and provides a 4-20mA output signal proportional to the measured pressure.

Series: HU-L24 Series, HU1502I Series and HU1502SS Series

*Conforms to the following Standards*

EN 60079-0:2012/A11:2013

EN 60079-11:2012

**Markings:** : ATEX: Ex II 1G Ex ia IIB T4 Ga (Ta = -40°C to +85°C)

**Supplementary Information:**

The product described in this Declaration of Conformity complies with the Applicable European Directives and relevant sections of the Applicable International Standards. The signature on this document authorizes the distinctive European mark to be applied to the equipment described.

**Authorized Signature:** \_\_\_\_\_

*Karl Reid*  
Karl Reid, Product Line Manager







**Automation Products Group, Inc.**

Tel: 1/888/525-7300 • Fax: 1/435/753-7490 • [www.apgsensors.com](http://www.apgsensors.com) • [sales@apgsensors.com](mailto:sales@apgsensors.com)