

AUTOMATION

PRODUCTS
GROUP, INC.

Operator's Manual

DCR-1006A

Level Controller

Rev. B2 (7/15)

DOC 9004120



Automation Products Group, Inc.

Table of Contents

<i>Warranty</i>	3
<i>Understanding Ultrasonics</i>	4-5
<i>Installation</i>	6-8
<i>Wiring</i>	9-13
<i>DCR-1006A Terminals</i>	9
<i>Powering the DCR-1006A</i>	9
<i>Sensor Wiring</i>	10
<i>RST Module Wiring</i>	10
<i>4-20mA Wiring</i>	11
<i>Switched Input/Relay Wiring</i>	12-13
<i>Programming</i>	14-38
<i>Basic Parameters</i>	16-17
<i>Ultrasonic Parameters</i>	18-21
<i>Application Types</i>	22-29
<i>Outputs</i>	30-34
<i>APG Modbus Software</i>	35-38
<i>Inspection and Maintenance</i>	39
<i>Specifications</i>	39

- **Warranty and Warranty Restrictions**

APG warrants its products to be free from defects of material and workmanship and will, without charge, replace or repair any equipment found defective upon inspection at its factory, provided the equipment has been returned, transportation prepaid, within 24 months from date of shipment from factory.

THE FOREGOING WARRANTY IS IN LIEU OF AND EXCLUDES ALL OTHER WARRANTIES NOT EXPRESSLY SET FORTH HEREIN, WHETHER EXPRESSED OR IMPLIED BY OPERATION OF LAW OR OTHERWISE INCLUDING BUT NOT LIMITED TO ANY IMPLIED WARRANTIES OF MERCHANTABILITY OR FITNESS FOR A PARTICULAR PURPOSE.

No representation or warranty, express or implied, made by any sales representative, distributor, or other agent or representative of APG which is not specifically set forth herein shall be binding upon APG. APG shall not be liable for any incidental or consequential damages, losses or expenses directly or indirectly arising from the sale, handling, improper application or use of the goods or from any other cause relating thereto and APG's liability hereunder, in any case, is expressly limited to the repair or replacement (at APG's option) of goods.

Warranty is specifically at the factory. Any on site service will be provided at the sole expense of the Purchaser at standard field service rates.

All associated equipment must be protected by properly rated electronic/ electrical protection devices. APG shall not be liable for any damage due to improper engineering or installation by the Purchaser or third parties. Proper installation, operation and maintenance of the product becomes the responsibility of the user upon receipt of the product.

Returns and allowances must be authorized by APG in advance. APG will assign a Return Material Authorization (RMA) number which must appear on all related papers and the outside of the shipping carton. All returns are subject to the final review by APG. Returns are subject to restocking charges as determined by APG's "Credit Return Policy".

• Understanding Ultrasonics

Ultrasonic sensors use a transducer to transmit bursts of ultrasonic sound waves. Each burst contains a series of pulsed sound waves that emit in the shape of a cone, reflect off the target, and are detected by the sensor. The time required for the sound waves to travel to and from the target is converted into a distance measurement by the sensor. Ultrasonic sensing is affected by several factors including the target surface, distance, size, and angle. The following considerations will help ensure the best possible target conditions.

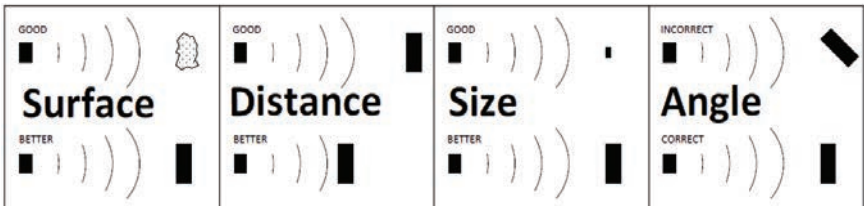

Surface

The ideal target surface is hard and smooth. This type of surface will reflect a greater amount of signal than a soft or uneven surface. Sound wave absorbent materials, such as granules and powders, will reduce the operating range of the sensor and decrease measurement accuracy.

Distance

Sound wave attenuation increases as the distance traveled increases. Therefore, targets at longer ranges require better reflective characteristics than targets that are closer to the sensor.

Size

A large object will have a greater surface area to reflect the signal than a smaller one. Therefore, a large target will be detected at a greater distance than a small target. The surface area recognized as the target will generally be the portion closest to the sensor.

Angle

The inclination of the object's surface in relation to the sensor face will affect the strength of the reflected sound waves. Surfaces perpendicular to the sensor will reflect more signal directly back to the sensor. If a surface is more than a few degrees off perpendicular, enough of the signal will be reflected away from the sensor that the target will not be detected. Generally speaking, a target angle greater than 5 degrees off perpendicular will not be detected. The target angle becomes increasingly critical as the distance to the target increases.

Environmental Conditions

Temperature, humidity, vapors, dust, and pressure can affect the sensor's performance. APG ultrasonic sensors are designed to compensate for many of these conditions. However, if the conditions are extreme, sensor performance can be degraded enough to require the use of a longer-range sensor than normal conditions would require. Ultrasonic sensors may not be suitable for applications with heavy chemical vapors (such as solvents or gasoline), heavy dust or when significant surface foam is present.

• Installation

Proper sensor mounting is critical for successful operation of an ultrasonic sensor. Using the following guidelines can help ensure trouble free installation and operation:

- Ensure that the sensor face is perpendicular to the target surface. If the target is more than a few degrees off perpendicular, it may not be detected. Targets at greater distances will require more precise sensor alignment.
- Mount the sensor in a location that provides an unobstructed column of air from the sensor to the target. The required width of the air column depends on several factors, including the angle and reflective characteristics of any potential targets on the edge of the column, the sensitivity setting of the sensor, the maximum distance to the target, and the reflective characteristics of the target itself. Generally speaking a 3 to 4 foot diameter unobstructed column is sufficient even at longer ranges.

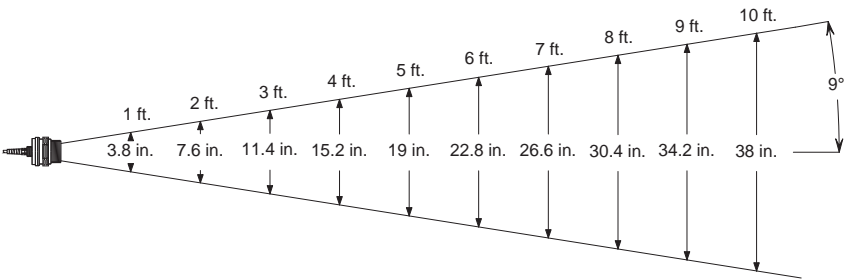

Typical beam spread of a sensor operating at maximum sensitivity

NOTE: Stilling pipes are an excellent solution for liquid level applications where an unobstructed path to the target is not feasible (see stilling pipe mounting on page 9 for details).

- When mounting outdoors, it's best to shade the sensor from direct sunlight. Direct sunlight can warm the sensor housing above the ambient temperature causing false temperature readings and overcompensation by the sensor.

- Always mount above the highest anticipated target level by at least the published minimum blanking distance. If a target enters into the blanking area, error in the detection will occur. It is always advisable to allow for sufficient headroom to ensure that the target does not enter the blanking area.
- Generally it is advisable to mount the sensor away from any vessel fill spouts. However, if heavy foam is expected, it is often helpful to mount the Sensor near a fill spout where the foam is being dispersed.
- Avoid mounting the sensor in the direct center of a tank with a significantly domed top. A domed top can act as parabolic dish, amplifying small undesired signals that may be present inside the tank.
- Avoid mounting the sensor in close proximity to tank walls, especially on tanks with corrugated walls or in applications where product buildup on the tank walls may occur.

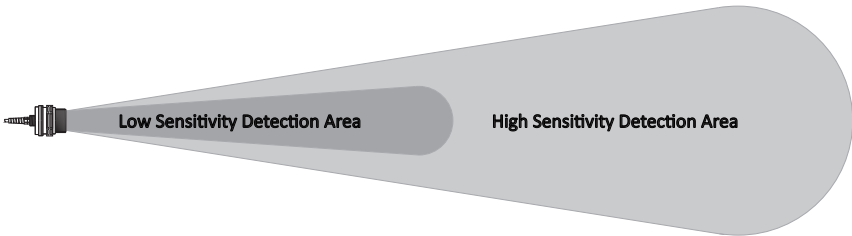

Stand Pipe Mounting

Stand pipes are used to provide headroom at the top of a tank when the target is expected to come closer to the sensor than the minimum blanking distance. It's very critical that the stand pipe be installed perpendicular to the target. This is especially important on longer range applications. The pipe must have smooth walls (no joints) and no burrs or obstructions. If possible, cut the end of the pipe at a 10°-45° angle (see drawing). Use the largest diameter pipe and shortest length possible. As a general rule, the diameter of the pipe should be 1/2 the length. The pipe ID must remain the same through it's entire length.

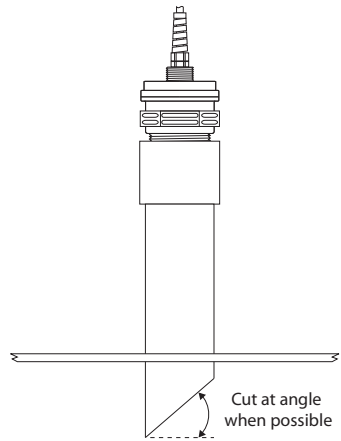

Stilling Pipe Mounting

Stilling pipes provide access to difficult areas and help eliminate problems with foam. The pipe must have smooth walls (no burrs or joints). Because the sound waves will concentrate and propagate down the inside walls of the tube, any irregularities on the tube walls may produce echo returns and cause false readings. Stilling pipes are limited to liquid targets that will not leave heavy deposits on the tube walls. Because the sound waves are confined inside the pipe, it is usually necessary to greatly reduce the sensors sensitivity and pulses settings. A vent hole must be provided at the top of the pipe. Be sure to keep the vent hole inside of the blanking area.

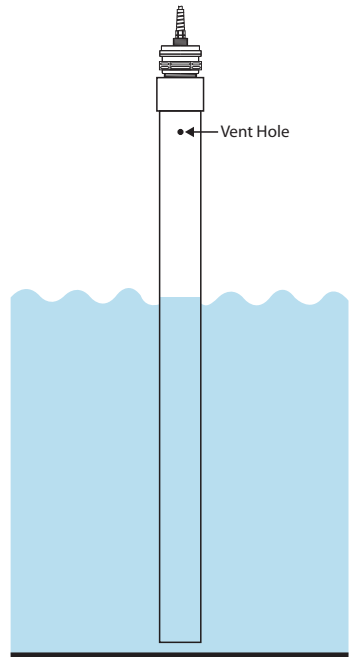

• **Wiring**

DCR-1006A Wiring Terminals

DCR-1006A wiring terminals are accessible by unscrewing and then lifting off the front (top) face.

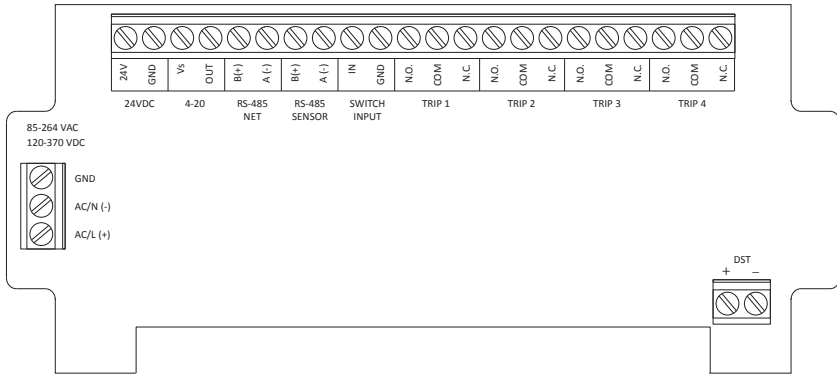

Powering the DCR-1006A

Power to the DCR-1006A can be supplied from either 85-264 VAC or 12-24 VDC.

Powering with AC Voltage

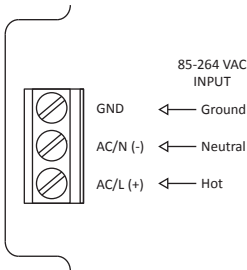

OR

DC Voltage Powered

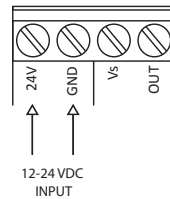

NOTE: terminals will source 24 VDC when controller is being powered via AC voltage.

Sensor Wiring

The DCR-1006A is compatible with most DST, MNU, and MPX series sensors.

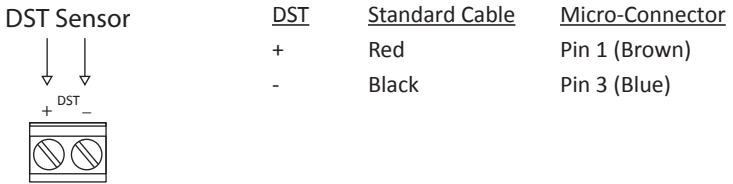
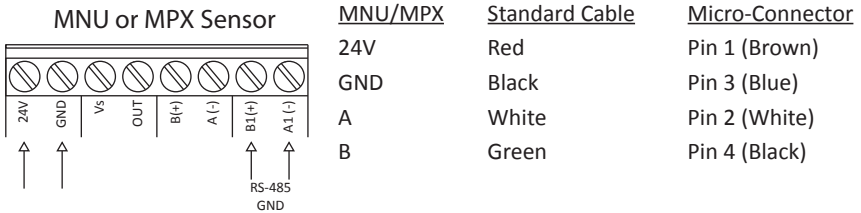

RST-5000 series or RST-6001 Communication Module Wiring

The DCR-1006A can be connected to an RST-6001 RS-485-to-USB module for interfacing with the APG Modbus Software, or to an RST-5000 series internet communications module to provides remote access to the DCR’s readings and settings. The RS-485 NET A and B terminals are the only connection required for either RST module.

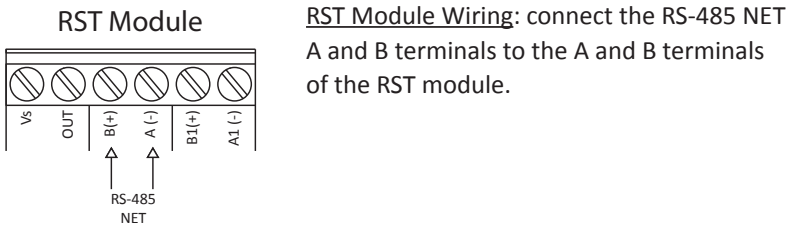

4-20mA Output Wiring

The 4-20mA output runs on an independent isolated circuit that must be supplied 9-28 VDC in order to operate. The source voltage (V_s) can be supplied from the 24 VDC source on the DCR-1006A, or from an external power source in an isolated circuit as shown below.

4-20mA Sourced Wiring

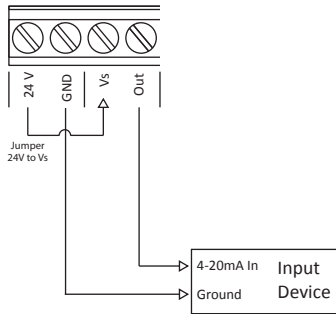

Isolated 4-20mA Wiring

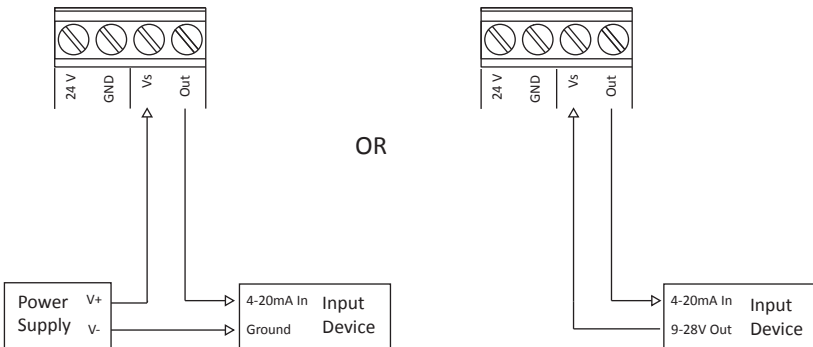

Wiring the Switched Input for High/Low Level Backup

The DCR's Switched Input can be connected to simple switching device, such as a float switch, to provide a high/low level backup and prevent dry pumping or overflow conditions in the event of an ultrasonic sensor failure or malfunction.

Normally Open Switched Input (Emergency Stop)

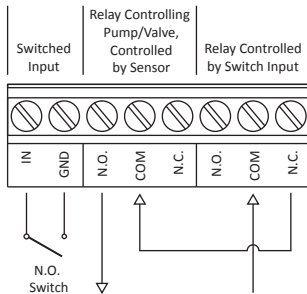

Trip 1 (NO) is controlled by the sensor (see Relay Trip Types and Relay Logic Diagrams on pages 32-33), closing for ON conditions. If the NO input switch closes, Trip 2 will open, breaking the circuit through Trip 1.

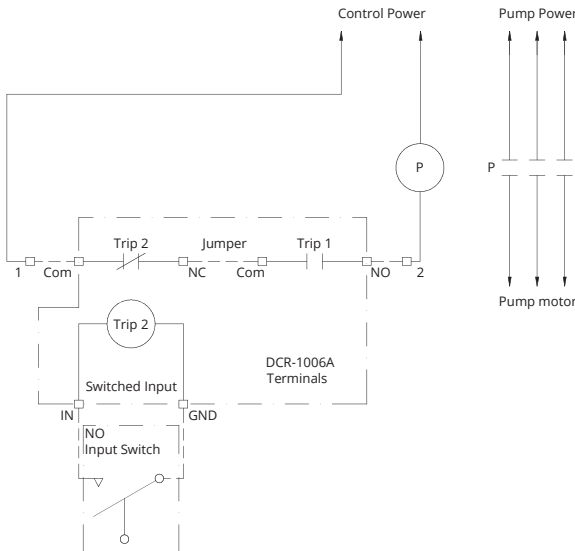

DCR Switched Input as E-Stop Control Wiring

Normally Closed Switched Input (Start Prevention)

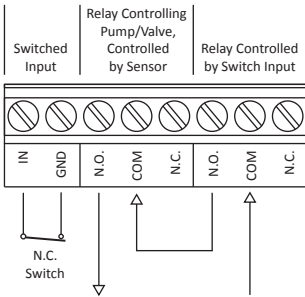

Trip 1 (NO) is controlled by the sensor (see Relay Trip Types and Relay Logic Diagrams on pages 32-33), closing for ON conditions. Since Trip 2 is also NO, both trips must be active (ON) for the Pump/Valve circuit to be complete.

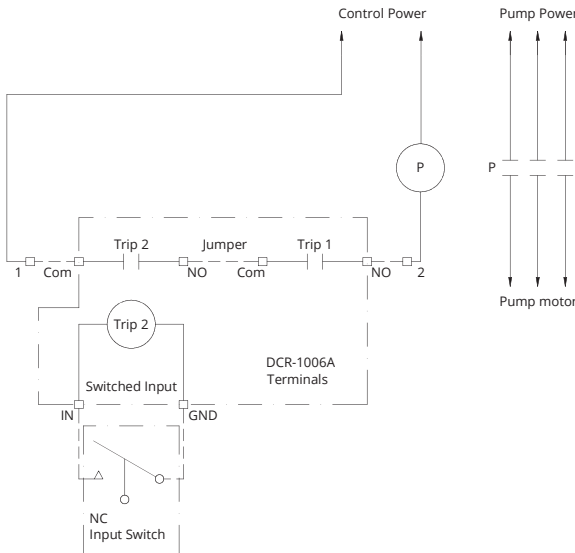

DCR Switched Input as Start Prevention Control Wiring

• Programming

The DCR-1006A can be programmed using the on-board push buttons or by using the RS-485 NET interface to communicate with APG's Modbus software or RST-5003 communications module.

Push Button Functions:

ENTER

Opens the programming menu, selects menu options, accepts parameter settings, and steps left one digit within any numeric settings.

NOTE: In order to save changes to a parameter setting, the ENTER button must be used to exit the setting.

BACK

Steps back (upward) one level within the menu. Steps right one digit within any numeric parameter setting.

NOTE: Exiting a parameter setting using the BACK button will not save any changes made to setting.

UP and DOWN

Used to cycle through the options within each menu level or to increase or decrease the value of the flashing digit within a numeric setting.

Upper Level Menu Structure

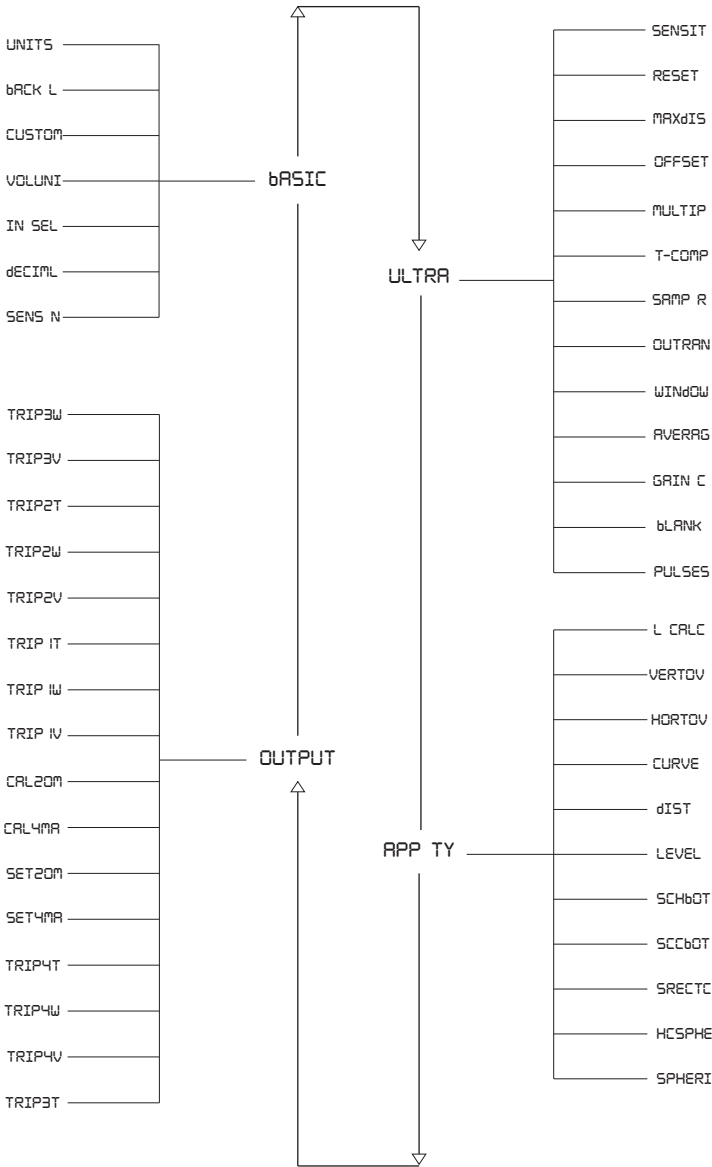

• bASIC (Basic Parameters)

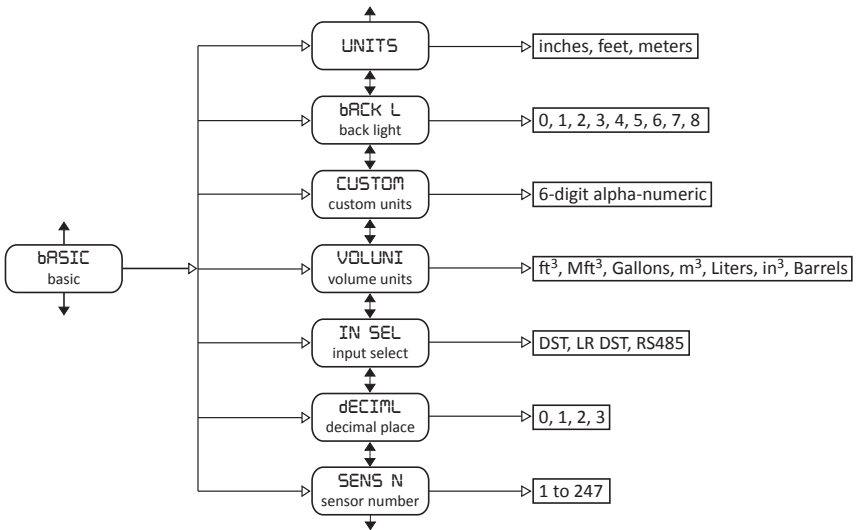

UNITS:

Determines the unit of measure used in all dimensional parameter settings, including the Maximum Distance, Filter Window, Blanking, and all Application Type dimensional parameters. The Units setting also determines the unit of measure for the Calculated Reading when operating in Application Types 1, 2 or 7.

NOTE: the decimal place position for all dimensional parameters remains in a fixed position based on the Units selected, as shown below:

Meters: 0.000 (3 decimal places)

Feet: 0.00 (2 decimal places)

Inches: 0.0 (1 decimal place)

bACK L (Back Light):

Allows the user to adjust the intensity of the display backlight. There are 9 settings from off to 100% intensity.

CUSTOM (Custom Units):

Allows the user to define a custom alphanumeric label for the Curve Fit and Linear Calculation Application Types.

VOLUME (Volume Units):

Determines the unit of measure for the volumetric Application Types. Options: Cubic Feet, Million Cubic Feet, Gallons, Cubic Meters, Liters, Cubic Inches, Barrels.

IN SEL (Input Select):

Selects the sensor input used by the controller.

DST: Standard DST sensor

LR DST: Long Range DST (DST-3434)

RS485: (MNU or MPX sensors only)

NOTE: when connecting a new RS-485 sensor to the DCR-1006A, set the Input Select to DST (with the new RS-485 sensor connected), then switch the Input Select to RS485. This will initiate the DCR-1006A to upload and configure the parameter settings in the RS-485 sensor for proper operation with the DCR-1006A.

DECIMAL (Decimal Place):

Sets the decimal place position in the Calculated Reading.

Example: a reading of 26.573 (gallons, etc.) will be displayed as follows:

Decimal Place = 0	Volume = 27
Decimal Place = 1	Volume = 26.6
Decimal Place = 2	Volume = 26.57
Decimal Place = 3	Volume = 26.573

NOTE: the decimal place in all dimensional parameters is fixed based on the unit of measure selected (see Units on previous page)

SENS N (Sensor Number):

Sets the Modbus address number for the DCR-1006A when its interfacing with an RST-5003 module or the APG Modbus software.

• **ULTRA (Ultrasonic Sensor Parameters)**

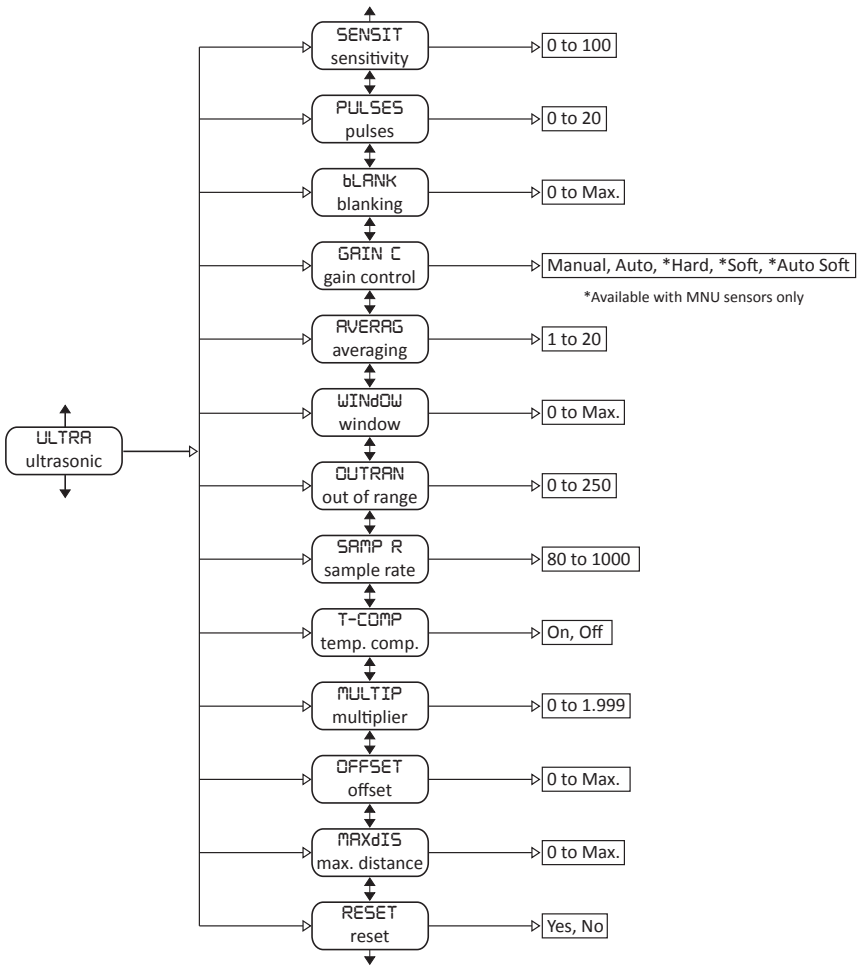

SENSIT (Sensitivity):

Controls the level of amplification applied the returning target echoes (signals). The sensitivity setting is expressed as a percentage: 0 to 100%.

PULSES:

Controls the number of sound wave pulses sent in each ultrasonic burst. The greater the number of pulses, the stronger the transmitted signal. Range: 0 to 20 pulses.

bLANK (Blanking):

Sets the distance (in the selected Units), beginning at the sensor face, to the point where target signals will be accepted. All targets closer than the blanking distance will be ignored. The blanking should never be set to less than the minimum range specification of the sensor. If the target enters the blanking area, reading errors will occur.

GAIN C (Gain Control):

Determines how the sensor applies gain to the returning target echoes.

Manual: Sensitivity and Pules remain constant.

Autosense: the sensor continually adjusts the Pulses and Sensitivity (within the set parameter bounds) in order to optimize the signal strength.

***Hard Target:** used for highly reflective targets. Targets echoes at close range are amplified less.

***Soft Target:** used for harder to detect targets. Targets at close range are amplified more.

***Soft-Auto:** autosense using the soft target gain rate.

(*available with MNU sensors only)

AVERAG (Averaging):

Defines the number of target readings that will be averaged together to become the displayed reading. Each qualified target reading (see Filter Window and Out of Range Samples on next page) is placed into a first-in, first-out buffer and averaged with previous readings. A higher Averaging will result in smoother readings, but will also slow the response to rapid changes in the target distance.

MAXDIS (Maximum Distance):

Sets the distance (in the selected Units), beginning at the sensor face, to the point where the sensor will stop looking for target echoes. Targets detected beyond the Maximum Distance will be ignored.

WINDOW (Filter Window):

Sets the width of the target acceptance window (in the selected Units). The target acceptance window is a zone, centered around the current target reading, within which any target detected will be considered legitimate and figured into the Averaging buffer. Any target detected outside of the Window will be considered “out of range” and will be ignored based on the setting in the Out of Range Samples parameter (see below). The Filter Window extends both directions from the target reading. For example, if the sensor is detecting a target at 5 ft. and the Filter Window is set at 1 ft., then any target detected between 4 ft. and 6 ft. will be accepted.

OUTRAN (Out of Range Samples):

Determines the number of consecutive target readings that fall outside of the Filter Window before the “out of range” target is recognized as legitimate and figured into the averaging buffer. For example, suppose the Out Of Range Samples is set to 10. If a target is suddenly detected outside of the Filter Window, it will be ignored until it has been detected for 10 consecutive samples, at which point it will be qualified as a legitimate target. If the “out of range” target was detected for only 9 consecutive samples before moving out of the sensing area, then it wouldn't be acknowledged as a target and the reading would stay with the last qualified target sample.

SAMP R (Sample Rate):

Sets the interval between target readings. Options allow rates from 80 ms to 1000 ms (once per second). A higher Sample Rate will result in a more rapid response to target movements. Lowering the Sample Rate will help increase sensor lifespan and decrease the chance of detecting errant echoes. The Sample Rate should be set only as fast as is necessary for the application, to help preserve the life of the transducer. A sample rate of 500 to 1000 ms is usually appropriate for slow moving tank level applications.

T-COMP (Temperature Compensation):

Used to enable or disable the internal temperature compensation of the sensor. Enabling the internal temperature compensation can reduce the effects of temperature changes by 50% or more, depending on the temperature gradient through the sensing range.

MULTIP (Multiplier):

Sets the conversion Multiplier that will be applied to the sensor readings. The default is 1.000 and typically does not need to be adjusted. However, since the speed of sound is not constant through all environments, the multiplier parameter allows the user to adjust for variations in atmosphere when maximum accuracy is required.

OFFSET (Offset):

Adjusts the zero reference point of the sensor (in the selected Units). When the Offset is set to 0, the zero reference of the sensor is at the face of the transducer. Setting the Offset to a negative number will move the zero reference backward (behind the sensor face), while a positive setting will move the reference forward (in front of the sensor face).

NOTE: because of the nature of shifting the zero reference of the sensor while operating in Level mode or any of the volumetric calculation modes, adjusting the Offset will appear to have the opposite effect on the level reading. A negative Offset will cause the level or volume to increase, while a positive offset will cause the level/volume reading to decrease.

RESET (reset to factory defaults): resets all parameter values back to factory defaults.

NOTE: while the Sensitivity, Pulses, and Blanking parameters of an attached DST sensor will be reset to factory defaults by performing a reset function, these same parameters within an RS-485 based sensor (MNU or MPX) will not be changed by performing the reset function.

• APP TY Application Types

The DCR-1006A has 11 Application Type operating modes to convert the measurement to the target into a calculated reading, such as a tank volume. Refer to the following section for a descriptions and settings.

Note: all dimensional values must be entered in the selected Units.

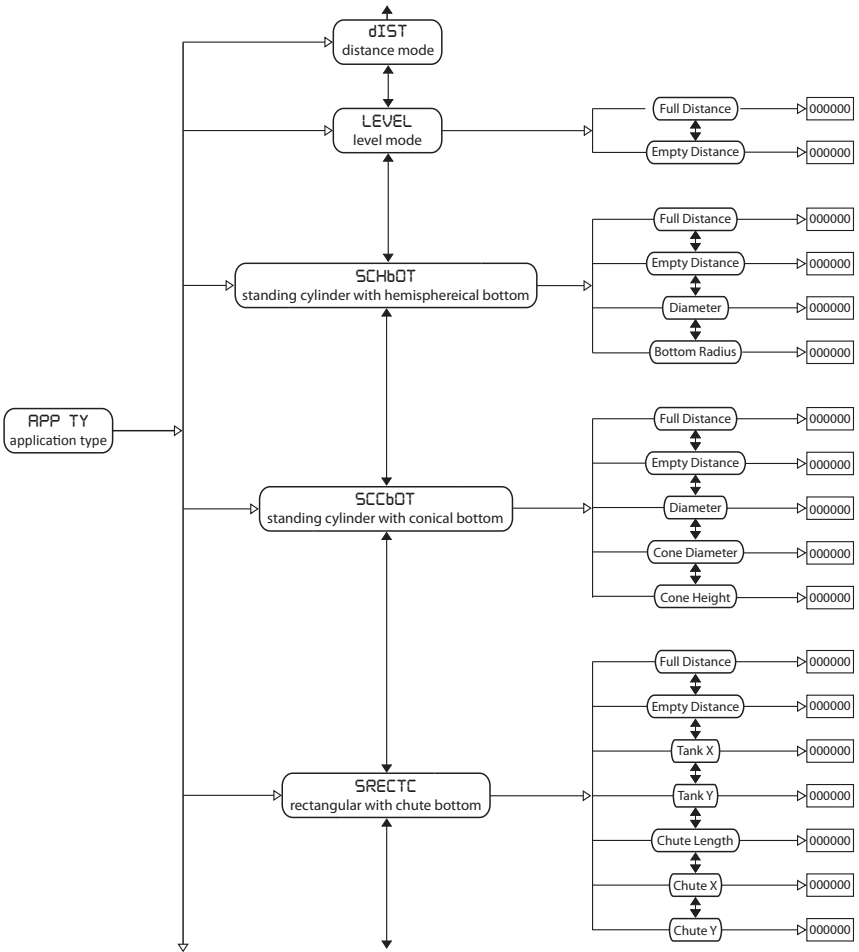

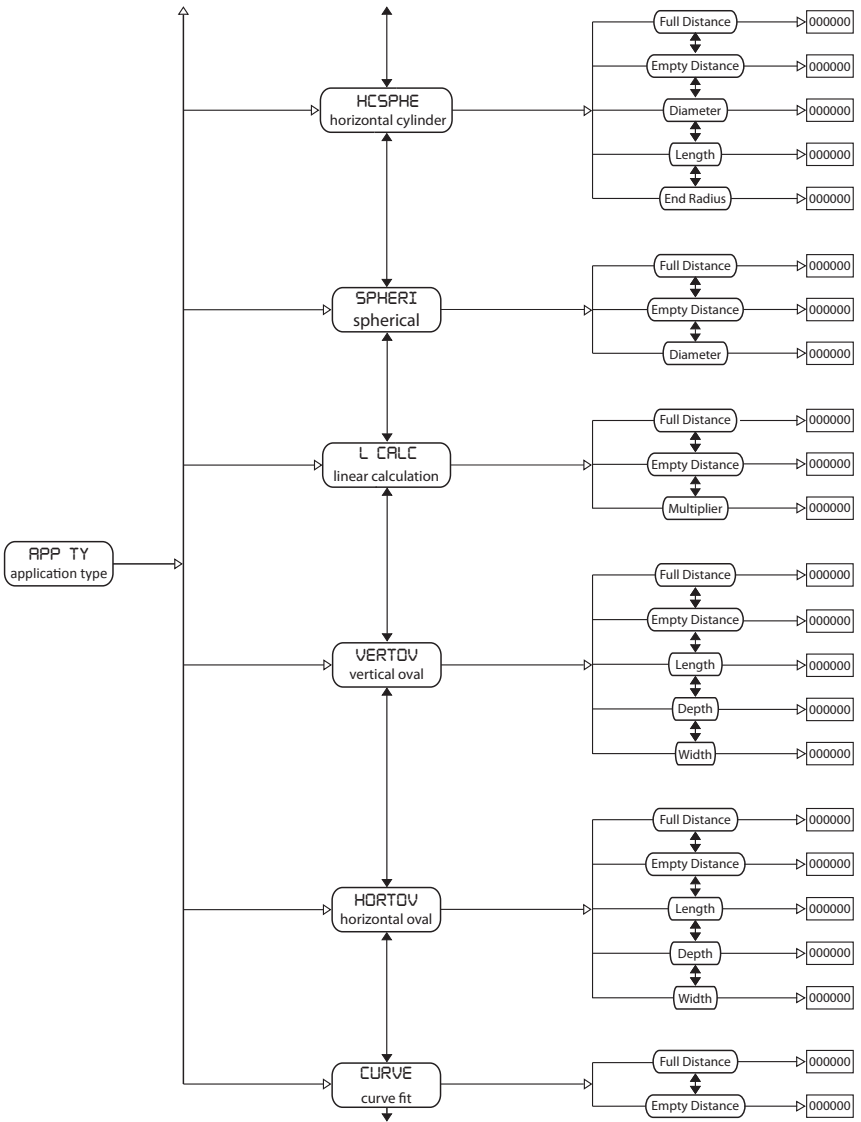

dIST (Distance to Target)

Displays the distance to the target in the selected Units.

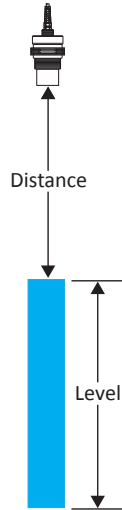

LEVEL (Depth of Level)

Displays the depth of level in the selected Units.

Parameters:

FULL d (Full Distance)

EMPTYd (Empty Distance)

SCHbOT (Standing Cylinder with Hemispherical Bottom)

Parameters:

FULL d (Full Distance)

EMPTYd (Empty Distance)

dIAMEt (Tank Diameter)

*bOTTRAd (Bottom Radius)

*set to 0 for flat bottom tanks.

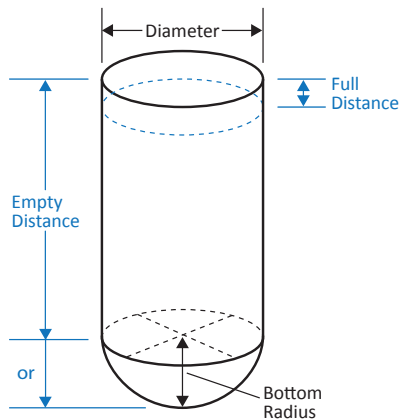

SCCbOT (Standing Cylinder with Conical Bottom)

Parameters:

- FULL d (Full Distance)
- EMPTYd (Empty Distance)
- dIAMEt (Tank Diameter)
- CONE L (Cone Length)
- CONE d (Cone Diameter)

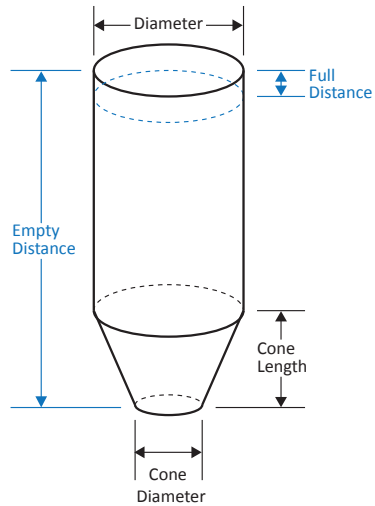

SRECTC (Standing Rectangle with Chute Bottom)

Parameters:

- FULL d (Full Distance)
- EMPTYd (Empty Distance)
- TANK X (Tank X)
- TANK Y (Tank Y)
- *CHUT X (Chute X)
- *CHUT Y (Chute Y)
- *CHUT L (Chute Length)

*set to 0 for flat bottom tanks.

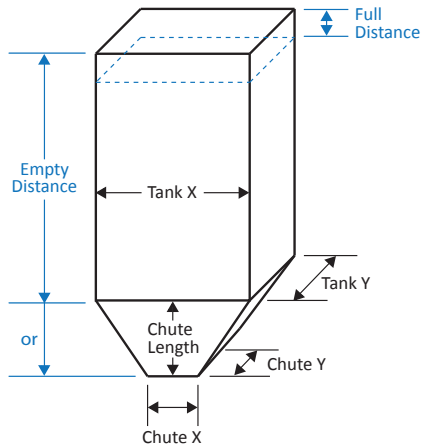

HCSPE (Horizontal Cylinder with Hemispherical Ends)

Parameters:

- FULL d (Full Distance)
- EMPTYd (Empty Distance)
- LENGTH (Tank Length)
- dIAMEt (Tank Diameter)
- *ENd RA (End Radius)

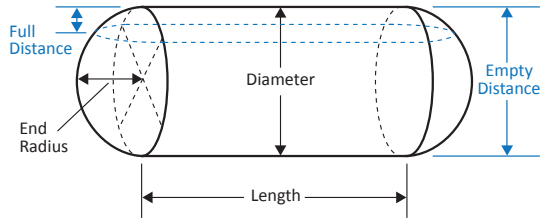

*set to 0 for flat ended tanks.

SPHERI (Sphere)

Parameters:

- FULL d (Full Distance)
- EMPTYd (Empty Distance)
- dIAMEt (Tank Diameter)

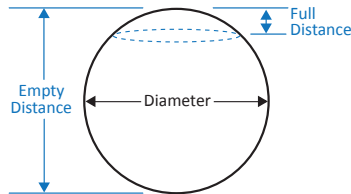

L CALC (Linear Calculation)

Applies a conversion multiplier to the level reading (based on the selected Units; inches, feet, meters).

Example: suppose the product in a tank weighs 206.25 pounds per inch of level. Assuming the Units are set to inches, the Multiplier would be 206.25

Parameters:

- FULL d (Full Distance)
- EMPTYd (Empty Distance)
- L MULT (Multiplier)

VERTOV (Vertical Oval)

Parameters:

- FULL d (Full Distance)
- EMPTYd (Empty Distance)
- LENGTH (Tank Length)
- DEPTH (Tank Depth)
- WIDTH (Tank Width)

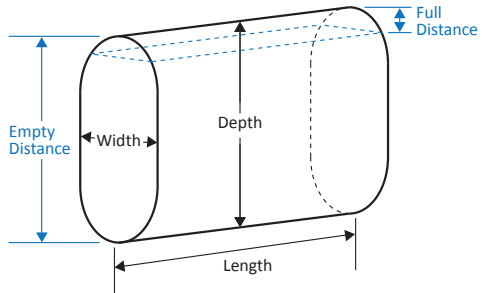

HORTOV (Horizontal Oval)

Parameters:

- FULL d (Full Distance)
- EMPTYd (Empty Distance)
- LENGTH (Tank Length)
- DEPTH (Tank Depth)
- WIDTH (Tank Width)

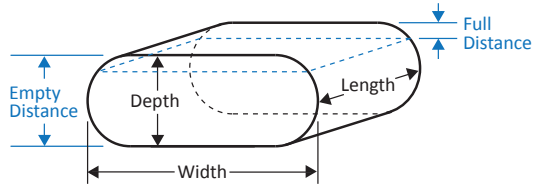

CURVE (Curve Fit)

Allows the sensor to mimic a tank strapping chart by using a 3rd degree polynomial equation to produce a “curve fit” approximation.

NOTE: The 4 coefficient values must be entered using the APG Modbus software, via an RST-6001 module. Refer to the instructions below to enter Curve Fit data.

Parameters:

FULL d (Full Distance)

EMPTYd (Empty Distance)

Open the APG Modbus software and select “Strapping Chart” from the “Tools” menu.

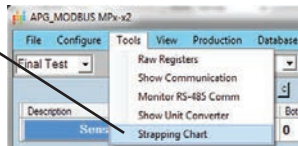

Enter the desired data points into the table.

OR

Use the “Load” button to recall a previously saved table.

OR

Import data from an electronic document by copying the data and then using the “Paste” button to populate the table.

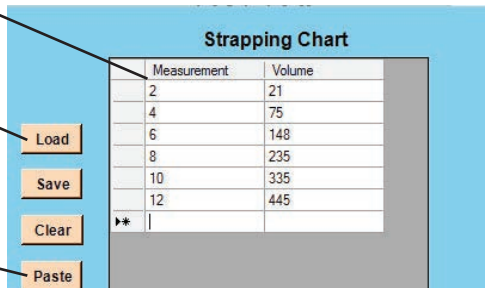

Once the all data points have been entered, click the “Calculate” button to determine the values required for the “curve fit” calculation.

NOTE: before clicking “Calculate” ensure that there is only one empty row following the last line of data (as shown). Use the keyboard “Delete”key to remove any addition empty rows.

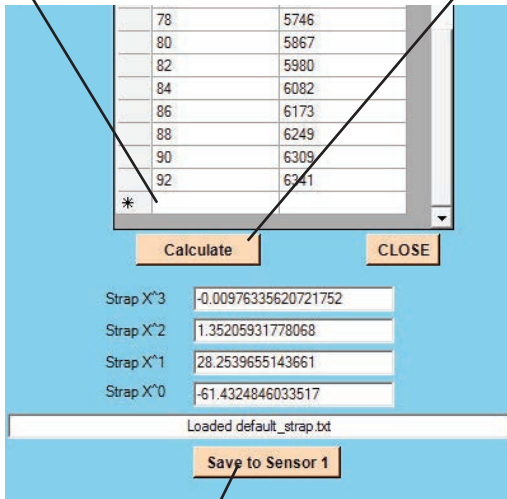

Click the “Save to Sensor” button to populate the appropriate Holding Register fields (see below) and close the Strapping Chart window.

435	t2t	NA	0	Send	Read
436	Strap X ³	0 - 1000000 mm	-0.00976335620721752	Send	Read
438	Strap X ²	0 - 1000000 mm	1.35205931778068	Send	Read
440	Strap X ¹	0 - 1000000 mm	28.2539655143661	Send	Read
442	Strap X ⁰	0 - 1000000 mm	-61.4324846033517	Send	Read
444	NA	0 - 1000000 mm	0	Send	Read

Send ALL Receive ALL

Click the “Send All” button at the bottom of the Holding Register page to write the curve fit values to the sensor.

• OUTPUT (Outputs)

The DCR-1006A is equipped with 4 SPDT relays and an isolated 4-20mA output.

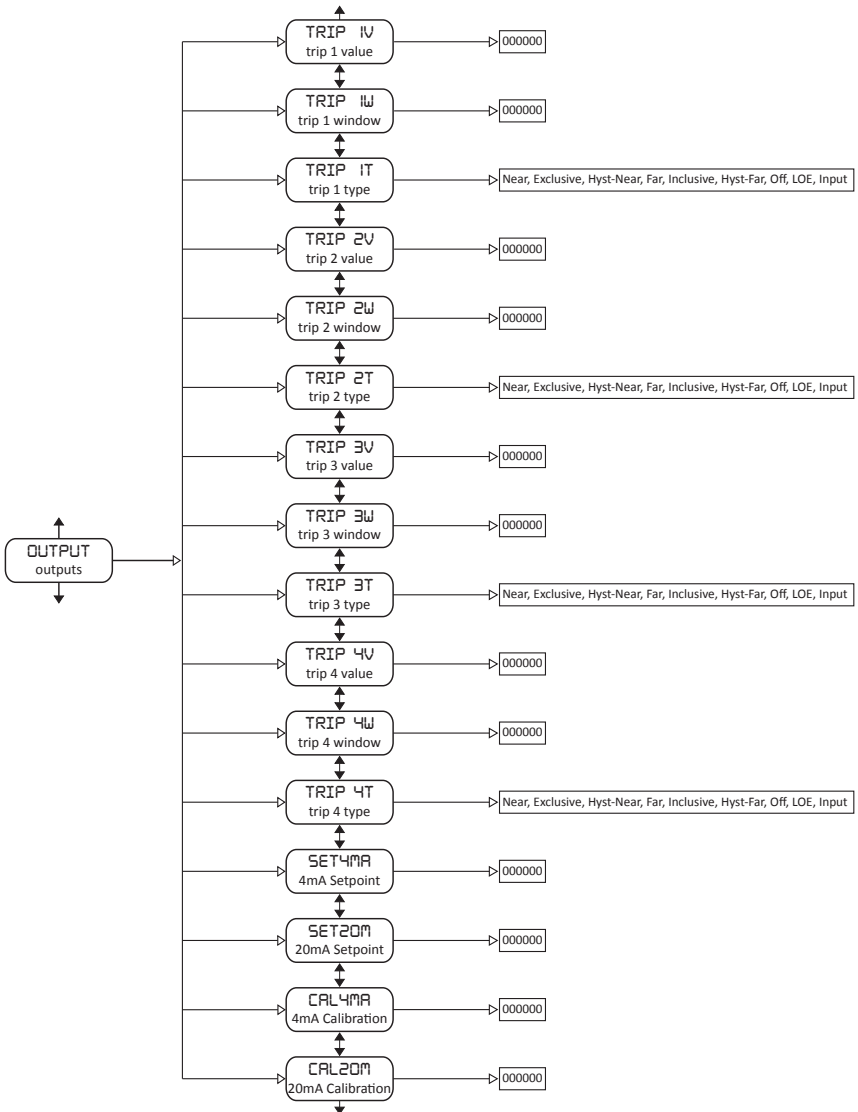

Relay Settings

NOTE: All Trip Value and Trip Window settings must be entered using the units being displayed. For example if the display is setup to read in gallons, then the Trip Value and Trip Window parameters would be set in gallons.

TRIP V (Trip Value):

Sets the reading (in the units being displayed) for the first actuation point of the relay.

TRIP W (Trip Window):

Sets the increase in the reading above the Trip Value to the secondary relay actuation point.

Example: if the 2nd actuation point is desired at 100 inches of level, and the Trip Value (the 1st actuation point) is set to 25 inches of level, then the Trip Window would need to be set to 75 inches ($25 + 75 = 100$).

TRIP T (Trip Type):

Determines the operational logic performed by the relay (refer to the descriptions and logic chart on following pages).

Relay Trip Types

NEAR:

Activates whenever the reading is less than the Trip Value.

EXCLSV (Exclusive):

Activates whenever the reading is less than the Trip Value or greater than the Trip Value + Trip Window.

H NEAR (Hysteresis Near):

Activates until the reading exceeds the Trip Value + Trip Window, then deactivates until the reading falls below the Trip Value.

FAR:

Activates whenever the reading is greater than the Trip Value.

INCLSV (Inclusive):

Activates whenever the reading falls within the Trip Window.

H FAR (Hysteresis Far):

Activates whenever the reading exceeds the Trip Value + Trip Window, and remains active until the reading drops below the Trip Value. Once deactivated the relay will remain inactive until the reading once again exceeds the Trip Value + Trip Window.

OFF:

Disables the relay.

LDE (Loss of Echo):

Holds the relay active unless a loss of echo condition (no target detected) occurs.

INPUT (Switched Input):

Activates or deactivate the relay based on the state of the switched input (closed or open).

Relay Logic for all Volumetric Modes

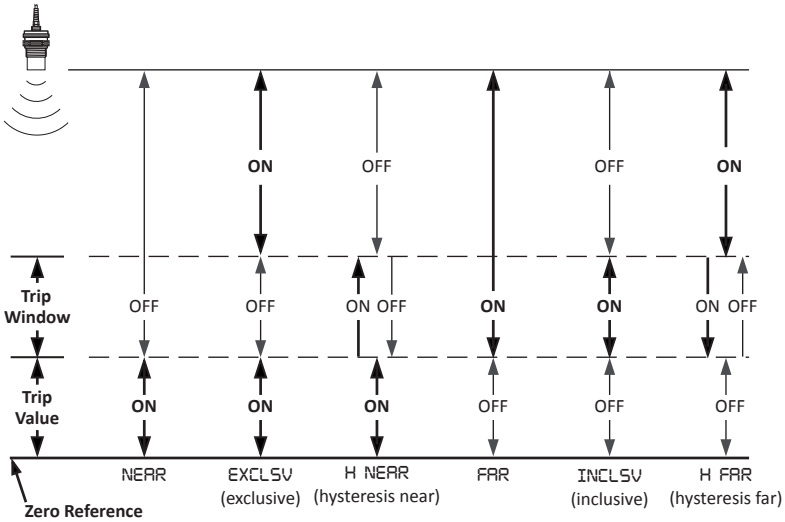

Relay Logic in Distance Mode

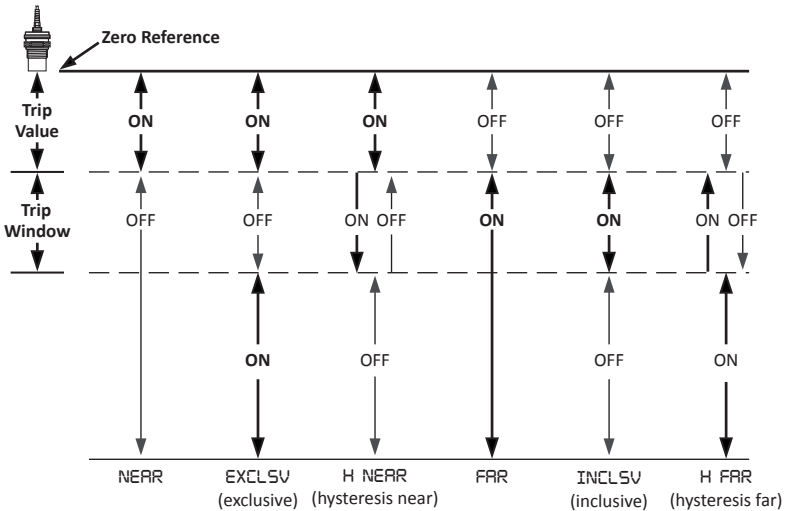

4-20mA Settings

NOTE: The 4-20mA Set Points must be entered in the units being displayed. For example if the display is setup to read in gallons, then the 4mA and 20mA Set Points would be set in gallons.

SET4mA (4mA Set Point):

Sets the reading to be associated with a 4mA output.

SET20M (20mA Set Point):

Sets the reading to be associated with a 20mA output.

CAL4mA (4mA Calibration):

Used to adjust the output current at the low end of the analog range (4mA endpoint). Increasing/decreasing the parameter value will increase/decrease the output current.

CAL20M (20mA Calibration):

Used to adjust the output current at the high end of the analog range (20mA endpoint). Increasing/decreasing the parameter value will increase/decrease the output current.

APG Modbus Software Communications via RST-6001

Step 1: select "Communication" from the "Configure" menu.

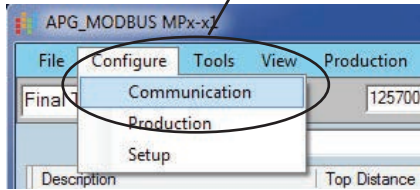

Step 2: select "DCR" from the Sensor Type menu, then click the "Save Config" button at the bottom of the screen.

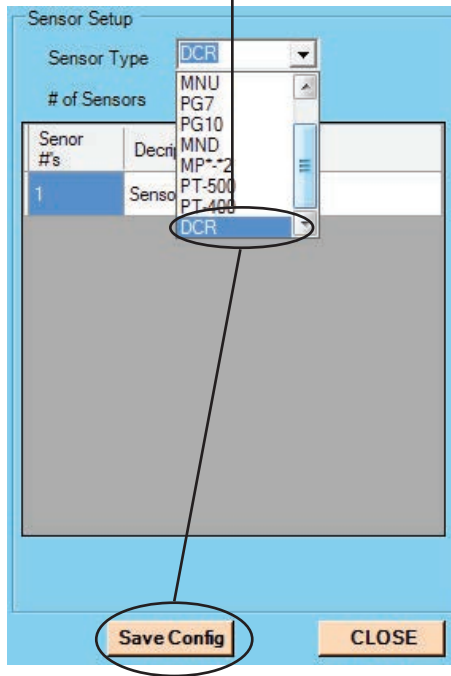

Step 3: set the mode of communication by selecting the .

Select the appropriate Comm Port when using direct serial communications.

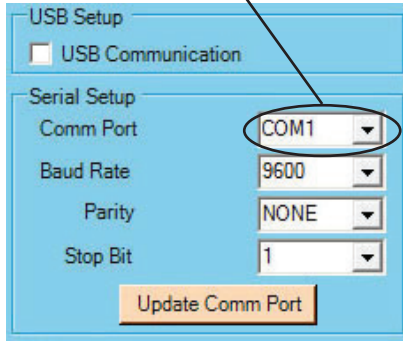

OR

Check the “**USB Communications (RST-6001)**” box when using the RST-6001 communications module.

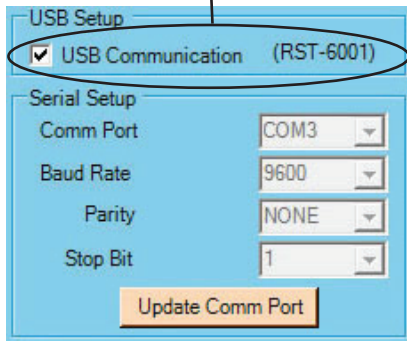

Using the APG Modbus Software

Click on the description to open the programming window for that address.

Sensor readings are displayed in the Input Registers table.

The screenshot displays the 'APG_Modbus DCR-1006A' software interface. At the top, there is a menu bar with 'File', 'Configure', 'Tools', 'View', 'Help', and a green 'START Communication' button. The date and time '12/10/2014 2:15:35 PM' are shown in the top right.

The main window is divided into several sections:

- Sensor Readings:** A table with columns 'Description', 'Reading (mm)', 'Calculated (raw)', 'Addr', and 'Register'. It shows 'Sensor 1' with a reading of 1802 mm and a calculated value of 70.9 in. at address 1.
- Sensor 1 Readings (Input Registers 0x04):** A table listing various sensor parameters such as Model Type, Reading (mm), Temperature C°, and Signal Strength.
- Sensor 1 Parameters (Holding Registers 0x03):** A large table listing parameters like Device Address (ID), Units, Application, Volume Units, and various distance and sensitivity settings.
- Diagram:** A schematic showing a sensor with a 'Zero' point and a 'Distance' measurement.
- Buttons:** 'Send ALL' and 'Receive ALL' buttons are located at the bottom right.

The register values should automatically populate. If not, click "Receive All" to retrieve the register values from the sensor.

(continued on next page)

To change an individual parameter, click on the value you wish to change, enter the desired value, then click the adjacent "Send" button to implement the change.

Addr	Function	Range	Value	Send	Read
400	Device Address	1 - 247	1	Send	Read
401	Units	1=ft,2=Inch,3=Meters	2	Send	Read
402	Application	0-11*	1	Send	Read
403	Volume Units	1-7*	3	Send	Read
404	Decimal Place	0-3	1	Send	Read
405	Max Distance	0 - 15250 mm	3500	Send	Read
406	Full Distance	0 - 15250 mm	0	Send	Read
407	Empty Distance	0 - 15250 mm	3500	Send	Read
408	Sensitivity	0 - 100	75	Send	Read
409	Pulses	0 - 20	10	Send	Read
410	Blanking	0 - 15250 mm	250	Send	Read
411	Gain Control	0 - 3	1	Send	Read
412	Averaging	1 - 100	20	Send	Read
413	Filter window	0 - 15250 mm	100	Send	Read
414	Out Of Range	1-255	20	Send	Read
415	Sample Rate	10 - 1000 msec	500	Send	Read
416	Multiplier	1 - 1999	1012	Send	Read
417	Offset	-15250 to 15250 mm	0	Send	Read
418	NA	NA	0	Send	Read
419	NA	NA	15	Send	Read
420	Temperature Comp	0 - 15.0°C	4	Send	Read

Send ALL Receive ALL CLOSE

To send all the register values as currently listed, click "Send All"

To retrieve the register values saved in a sensor, click "Receive All"

Note the color codes that designate the status of parameters during send/receive process.

Bad Comm.	Min. Max.	Sending	Received	Disabled
Value (Programmable)		Send	Read	

• Inspection and Maintenance

The DCR-1006A requires little maintenance but should be inspected periodically to ensure proper working order. Ensure that the wire connections are secure, sealed against the elements and free from corrosion.

• Specifications

Operating Voltage: 85-264 VAC
 12-24 VDC (Nominal) 15-28 VDC (Operational)
 9-28 VDC (4-20 mA Vs)

Housing: PBT/Polycarbonate blend

Dimensions (in.): 6.25 x 3.125 x 2.25

Environmental Rating: NEMA 6P

DST sensor Sample Rate: 80 to 1000 mS (programmable)

RST Display Resolution: 0.01 ft / 0.1" / 1 mm (unit dependent)

4-20 mA Output Accuracy: min. +/- 0.25% of detected range (with no temperature gradient)

Parameter Adjustments: via push buttons, RS-485 interface to PC-based APG Modbus Software via RST-6001, or RST-5000 series communications module.

Operating Temperature: -30 to 140 °F (-34 to 60 °C)

Relay Characteristics: 15 A @ 125 VAC 1/4 HP @ 125/250 VAC NC
 10 A @ 277 VAC 1/3 HP @ 125/250 VAC NO
 7 A @ 30 VDC
 10,000,000 operations

AUTOMATION

PRODUCTS
GROUP, INC.



Tel: 1/888/525-7300

1/435/753-7300

Fax: 1/435/753-7490

e-mail: sales@apgsensors.com

www.apgsensors.com

Automation Products Group, Inc.

1025 W. 1700 N.

Logan, UT 84321