

991 Thrust Transmitter

Datasheet

Bently Nevada Machinery Condition Monitoring

141618 Rev. K

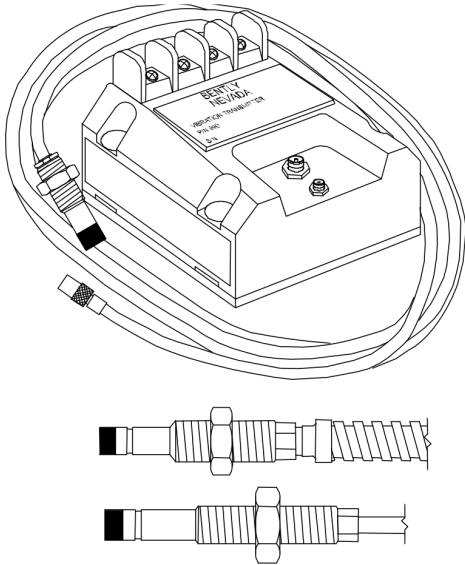

Description

The 991 Thrust Transmitter is intended primarily for the original equipment manufacturers (OEMs) of centrifugal air compressors or small pumps, motors, or fans who prefer to provide a simple 4 to 20 mA proportional axial displacement (thrust) signal as the input to their machinery control system. The transmitter is a 2-wire, loop-powered device that accepts input from our 3300 NSv proximity probe and its matching extension cable (available in 5 m and 7 m system length options). The transmitter conditions the signal into appropriate engineering units proportional to the shaft's axial position¹, and provides it as a 4 to 20 mA industry-standard signal for input to the control system where machinery protection alarming and logic occurs².

The 991 transmitter provides the following notable features:

- Integrated Proximitors Sensor requires no external unit
- Non-isolated "PROX OUT" and "COM" terminals plus a coaxial connector provide a dynamic vibration and gap voltage signal output for diagnostics³.
- Non-interacting zero and span potentiometers under the Transmitter label supports loop adjustment.
- Test Input pin allows quick verification of loop signal output, using a variable DC voltage source as the input.
- A Power-up Inhibit circuit eliminates signal errors due to line voltage transients.
- A Not OK/Signal Defeat circuit prevents high outputs or false alarms due to a faulty proximity probe or loose connection.
- Choice of DIN-rail clips or bulkhead mounting screws as standard options simplifies mounting.
- Potted construction for high humidity (up to 100% condensing) environments.



- Compatibility with 3300 NSv proximity probe allows transducer installation in small areas with minimal clearance, typical of centrifugal air compressors.

Notes:

1. Probe adjustment and range are critical in thrust position measurements. Incorrect probe gap settings may prevent the transmitter from reaching full-scale in either the normal or counter directions (no machinery monitoring). For proper adjustment, follow the instructions in the manual.
2. Thrust transmitters have many limitations when compared to a continuous monitoring system. They are a practical solution in some applications for measuring rotor axial position and are a valuable tool for trending thrust readings. While the transmitter is capable of alarming on thrust position and non-OK checking, monitor functions such as Timed OK channel defeat, Danger Bypass, and Trip Multiply cannot be used. In addition, PLCs attached to the thrust transmitter are not suitable for plant-wide diagnostic systems such as System 1 or Rule Paks.
3. The 991 Vibration Transmitter's "Prox Out" coaxial connector provides a non-isolated dynamic transducer signal for machinery diagnostics. You can connect this signal directly to battery-powered or isolated test equipment to diagnose machinery problems. However, since the "PROX OUT" signal is not isolated from the 4 to 20 mA loop signal, an interface is available (and strongly recommended) for signal isolation. The 990/991 Test Adapter conditions the 990 Transmitter's "PROX OUT" signal for use with ac-powered test equipment. The adapter also inverts and isolates the 990's transducer signal, making it suitable for equipment such as oscilloscopes and analyzers, and preserving industry-standard conventions for signal polarity. We strongly recommend that you use this test adapter for all applications to maintain isolation between test equipment and the loop signal, and to maintain machinery protection integrity.

Specifications

Unless otherwise noted, the following specifications apply at +22 °C (+72 °F) using a 3300 NSv Probe and Extension Cable, and an AISI 4140 steel target.

Electrical

Input	Accepts 1 non-contacting 3300 NSv Proximity Probe and extension cable.
Power	Requires +12 to +35 Vdc input at the transmitter terminal.
4 to 20 mA Signal Output	4 to 20 mA _{dc} over specified full-scale range in 2-wire configuration.
4 to 20 mA Loop Accuracy	Within ±1.5% over specified full scale range (typical). Accuracy is rated from the TEST signal input to the voltage measured across a 250 Ω loop resistance.
Maximum Loop Resistance	1,000 Ω including cable at 35 Vdc.
Current Limiting	23 mA typical.
Zero and Span	Non-interacting external adjustments.
Not OK/Signal Defeat	Signal output will go to less than 3.6 mA within 100 μs after a Not OK condition occurs. Signal output is restored within 0.1 seconds after the Not OK condition is removed.
Proximitor Sensor Output	Compatible with ungrounded, portable test equipment. When using grounded, ac-powered test equipment, use the 122115-01 Test Adapter for signal isolation.
Output Impedance	Prox Out has a 10 kΩ output impedance calibrated for a 10 MΩ load.
Linear Range	0.25 to 1.65 mm (10 to 65 mils) for Prox Out. Suitable for 0.6-0-0.6 mm or 25-0-25 mils current loop linear ranges.
Prox Out Incremental Scale Factor	7.87 mV/μm (200 mV/mil) ± 6.5% typical including interchangeability errors when measured in increments of 0.25 mm (10 mils) over the linear range using a flat 30 mm (1.2 inch) target.
Temperature Stability	Incremental scale factor remains within ±10% of 7.87 mV/μm (200 mV/mil) from 0 °C to +70 °C (+32 °F

	to +158 °F).
Minimum target size	9.5 mm (0.375 in) diameter.
Leadwire Length	Proximitor Sensor Output (BNC connector), maximum cable distance is 3 metres (10 feet).
Non-Hazardous, Zone 2 or Div 2 Hazardous area locations	13 km (8 miles) maximum between transmitter and receiving device for signal output.
Intrinsically Safe Hazardous area locations	See Hazardous Area Approvals on page 6.
Electrical Classification	General Purpose Approval by Canadian Standards Association (CSA/NRTL/C) in North America and by VDE in Europe. The 991 has the CE mark for Europe.

Maritime Approvals

American Bureau of Shipping (ABS) Type Approval	
Certification Number	06-HS177078-3-PDA

Environmental Limits

Transmitter Temperature	
Operating Temperature	-35 °C to +85 °C (-31 °F to +185 °F)
Storage Temperature	-51 °C to +100 °C (-60 °F to +212 °F).
Probe Temperature	
Operating Temperature	-35 °C to +177 °C (-31 °F to +350 °F).
Storage Temperature	-51 °C to +177 °C (-60 °F to +350 °F).
Relative Humidity	100% condensing, non-submerged, with protection of coaxial connectors.

Mechanical

Transducer Tip Material	Polyphenylene sulfide (PPS).
Transducer Case Material	AISI 303 or 304 Stainless Steel (SST).
Probe Cable	75Ω coaxial, fluoroethylene propylene (FEP) insulated.
Cable Armor (optional)	Flexible AISI 302 SST with optional FEP outer jacket.
Tensile Strength	222 N (50 lbf) probe case to probe lead, maximum.
Transmitter Weight	0.43 kg (0.9 lbm).
Total System Weight	0.82 kg (1.8 lbm) typical.

Compliance and Certifications

FCC

This device complies with part 15 of the FCC Rules. Operation is subject to the following two conditions:

- This device may not cause harmful interference.
- This device must accept any interference received, including interference that may cause undesired operation.

EMC

EN 61000-6-2

EN 61000-6-4

EMC Directive 2014/30/EU

ATEX

ATEX Directive 2014/34/EU

RoHS

RoHS Directive 2011/65/EU

Maritime

ABS 2009 Steel Vessels Rules

1-1-4/7.7,4-8-3/1.11.1,4-9-7/13

Hazardous Area Approvals



For the detailed listing of country and product specific approvals, refer to the *Approvals Quick Reference Guide* (108M1756) available from Bently.com.

CSA/NRTL/C

Class I, Div 2
 Groups A, B, C, D
 T5 @ $T_a \leq +85^\circ\text{C}$, Type 4
 Installed per Drawing 128838

ATEX/IECEx

 II 1 G
 Ex ia IIC T4 Ga

T4 @ $T_a = -35^\circ\text{C}$ to $+85^\circ\text{C}$

 II 3 G
 Ex nA IIC T4 Gc
 T4 @ $T_a = -35^\circ\text{C}$ to $+85^\circ\text{C}$

Entity Parameters

Zone 2

Power Supply: 28V

Zone 0/1

Terminal blocks E1-E2 "power supply 4-20 mA"	Terminal blocks E3-E4 and connector J2 "Proximitator"	Connector J3 "Probe"
$U_i \leq 28 \text{ V}$	$U_o \leq 28 \text{ V}$	$U_o \leq 28 \text{ V}$
$I_i \leq 120 \text{ mA}$	$I_o \leq 6 \text{ mA}$	$I_o \leq 100 \text{ mA}$
$P_i \leq 0.84 \text{ W}$	$P_o \leq 0.17 \text{ W}$	$P_o \leq 0.8 \text{ W}$
$C_i \leq 20 \text{ nF}$	$C_o \leq 80 \text{ nF}$	$C_o \leq 27.3 \text{ nF}$
$L_i \leq 10 \mu\text{H}$	$L_o \leq 1\text{H}$	$L_o \leq 5.3 \text{ mH}$

Ordering Information



For the detailed listing of country and product specific approvals, refer to the *Approvals Quick Reference Guide* (108M1756) available from Bently.com.

991-AA-BB-CC-DD

A: Full-scale Option	
0 6	0.6 -0- 0.6 mm
2 5	25-0-25 mils
B: System Length Option	
5 0	5.0 metres (16.4 feet)
7 0	7.0 metres (23.0 feet)
C: Mounting Option	
0 1	35 mm DIN-rail clips
0 2	Bulkhead screws
0 3	DIN clips and screws
D: Agency Approval Option	
0 0	Not required
0 1	CSA Division 2
0 5	CSA Division 2, ATEX Zone 0, ATEX Zone 2 and includes ABS maritime approval

3300 NSv Proximity Probes

Part Number-AA-BB-CC-DD-EE

330901	3300 NSv Probe, 1/4-28 UNF thread, without armor.
330902	3300 NSv Probe, 1/4-28 UNF thread, with armor.
330908	3300 NSv Probe, 3/8-24 UNF thread, without armor.
330909	3300 NSv Probe, 3/8-24 UNF thread, with armor.

A: Unthreaded Length Option



Unthreaded length must be at least 0.7 in less than the case length.

Order in increments of 0.1 in

Length configurations:

Minimum length: 0 in

Maximum length: 9.2 in

Example:**0 40.4** in

B: Case Length Option

Order in increments of 0.1 in

Threaded length configurations:

Minimum length: 0.8 in

Maximum length: 9.9 in

Example: **3 5 3.5** in

C: Total Length Option

0 5	0.5 metre (1.67 feet)
1 0	1.0 metre (3.25 feet)
5 0	5.0 metres (16.4 feet)
7 0	7.0 metres (23 feet)

D: Connector Option

0 1	Miniature coaxial ClickLoc connector with connector protector, standard cable
0 2	Miniature coaxial ClickLoc connector, standard cable
1 1	Miniature coaxial ClickLoc connector with connector protector, FluidLoc cable
1 2	Miniature coaxial ClickLoc connector attached, FluidLoc cable

E: Agency Approval Option

0 0	Not required
0 5	Multiple Approvals (CSA NRTL/C and BASEEFA/CENELEC, which includes CSA Division 2)

3300 NSv Probes, Metric

Part Number-AA-BB-CC-DD-EE

330903	3300 NSv Probe, M8 x 1 thread, without armor.
330904	3300 NSv Probe, M8 x 1 thread, with armor.
330905	3300 NSv Probe, M10 x 1 thread, without armor.
330910	3300 NSv Probe, M10 x 1 thread, with armor.

A: Unthreaded Length Option

 Unthreaded length must be at least 20 mm less than the case length.

Order in increments of 10 mm

Untreated length configurations:

Minimum length: 0 mm

Maximum length: 230 mm

Example: **06** 60 mm

B: Case Length Option

Order in increments of 10 mm

Minimum length: 20 mm

Maximum length: 250 mm

Example: **25** 250 mm

C: Total Length Option

0 5	0.5 metre (1.67 feet)
1 0	1.0 metre (3.25 feet)
5 0	5.0 metres (16.4 feet)
7 0	7.0 metres (23 feet)

D: Connector Option

0 1	Miniature coaxial ClickLoc connector with connector protector, standard cable
0 2	Miniature coaxial ClickLoc connector, standard cable
1 1	Miniature coaxial ClickLoc connector with connector protector, FluidLoc cable
1 2	Miniature coaxial ClickLoc connector attached, FluidLoc cable

E: Agency Approval Option

0 0	Not required
0 5	Multiple Approvals (CSA NRTL/C and BASEEFA/CENELEC, which includes CSA

Division 2)

3300 NSv Reverse Mount Probe

330906-02-12-CC-DD-EE, 3/8-24 UNF threads

330907-05-30-CC-DD-EE, M10 x 1 UNF threads

C: Total Length Option

0 5	0.5 metre (1.67 feet)
1 0	1.0 metre (3.25 feet)
5 0	5.0 metres (16.4 feet)
7 0	7.0 metres (23 feet)

D: Connector Option

0 2	Miniature coaxial ClickLoc connector, standard cable
1 2	Miniature coaxial ClickLoc connector attached, FluidLoc cable

E: Agency Approval Option

0 0	Not required
0 5	Multiple Approvals (CSA NRTL/C and BASEEFA/CENELEC, which includes CSA Division 2)

Extension Cable

330930-AAA-BB-CC

A: Cable Length Option

0 4 0	4.0 metres (13.1 feet)
0 4 5	4.5 metres (14.8 feet)
0 6 0	6.0 metres (19.7 feet)
0 6 5	6.5 metres (21.3 feet)

B: Armor Option

0 0	Without stainless steel armor
0 1	With FEP covered stainless steel armor
0 2	With stainless steel armor
0 3	Without stainless steel armor, with connector protector
0 4	With FEP covered stainless steel armor and connector protector
0 5	With stainless steel armor and connector protector

C: Agency Approval Option

0 0	Not required
0 5	Multiple Approvals (CSA NRTL/C and BASEEFA/CENELEC (which includes CSA Division 2))

Accessories

122115-01	990/991 Test Adapter. Package includes: 990/991 Test Adapter, 9V battery, Universal ac Adapter, Power Cord (North American), User Guide and Soft Carrying Case.
	<p>The 990/991 Test Adapter inverts and isolates the PROX OUT signal from the 991 Transmitter so you can connect 991 Transmitters to ac-powered diagnostic equipment. The Adapter modifies the PROX OUT signal so that it matches our Proximitator Sensor signals by performing these functions:</p> <ul style="list-style-type: none"> • Shifts the phase of the PROX OUT signal by 180° by changing the voltage from positive to negative • Isolates the transmitter from diagnostic equipment so that

	<p>equipment with different grounds will not affect the transmitter's 4-20 mA loop signal</p> <ul style="list-style-type: none"> • Reduces noise in the surrounding area from affecting the PROX OUT signal <p>The 990/991 Test Adapter provides the following benefits:</p> <ul style="list-style-type: none"> • Small size and weight for portable operation • Battery or ac adapter power options • Automatic shutoff circuit that powers down the unit when the battery is low • 2 channels, so that you can display an orbit for XY probe configurations.
	<ul style="list-style-type: none"> • 2 channels, so that you can display an orbit for XY probe configurations.

990/991 Test Adapter Accessories

123266-01	Coaxial Cable Kit. Includes 4 cables with length of 1.5 metres (5 feet) each.
02211505	Single coaxial cable with length of 1.5 metres (5 feet).

990/991 Test Adapter Spare Parts

01810700	Battery (9 volt alkaline).
02270056	AC adapter. Has universal ac input to 9 volts dc output. Input is 108 to 132 Vac with 120 Vac nominal, or 207 to 253 Vac with 240 Vac nominal.
02198937	Power cord (for North American ac power outlet).
123133	User Guide.

Probe and Transmitter Accessories

02173006	Bulk Cable (specify length in feet). 1.0 mm ² (18 AWG), 2-conductor, twisted, shielded cable used for the 4 to 20 mA loop. Also used for the PROX OUT signal on the 991 Transmitter's terminal strip.
123655	990 and 991 Transmitter Systems Installation Guide
330153-05	Cable Connector Kit. Package Includes 1 set of 75 Ω miniature male and female connectors, shrink tubing and 3300 Isolator Seal for protection of coaxial connectors.
163356	Connector Crimp Tool Kit. Includes one set of 75 Ω ClickLoc inserts and connector installation instructions. Supplied with carrying case.
330951-01	991 Mounting Screws (spares). Contains 4 screws.
284726	DIN rail mounting kit. Installed on the 990 Transmitter to allow mounting on 35 mm DIN rail

Graphs and Figures

Note: All dimensions shown in millimetres (inches) unless noted otherwise.

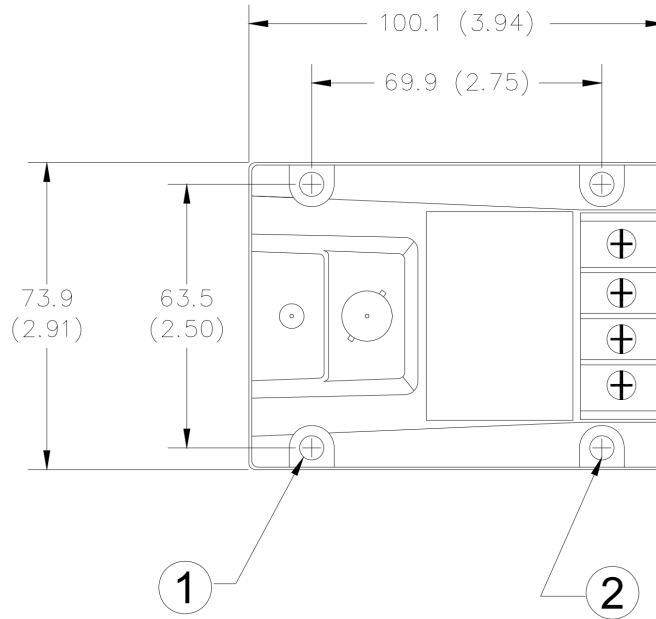

1. Mounting holes, 5.8 mm (0.23 in) diameter, 4 places
2. Bulkhead mount holes, 4 each. 6-32 x 1.326 screws provided when mounting option specified

Figure 1: 991 Thrust Transmitter Dimensions (Top View)

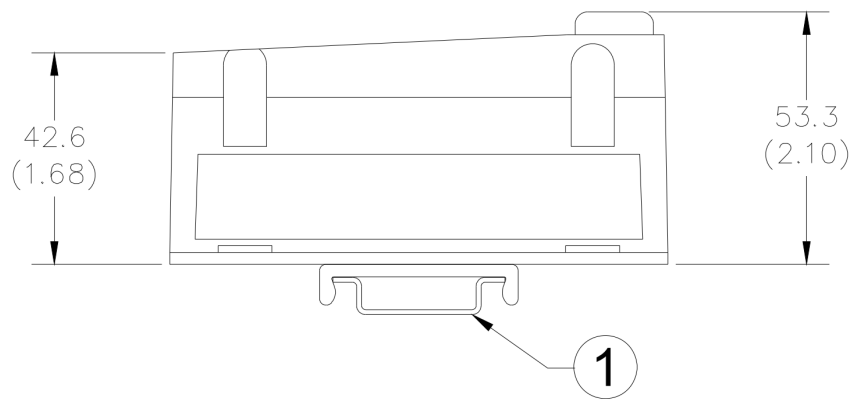

1. 35mm DIN rail DIN mount clips (when DIN rail mounting is specified)

Figure 2: 991 Thrust Transmitter Dimensions (Side View)

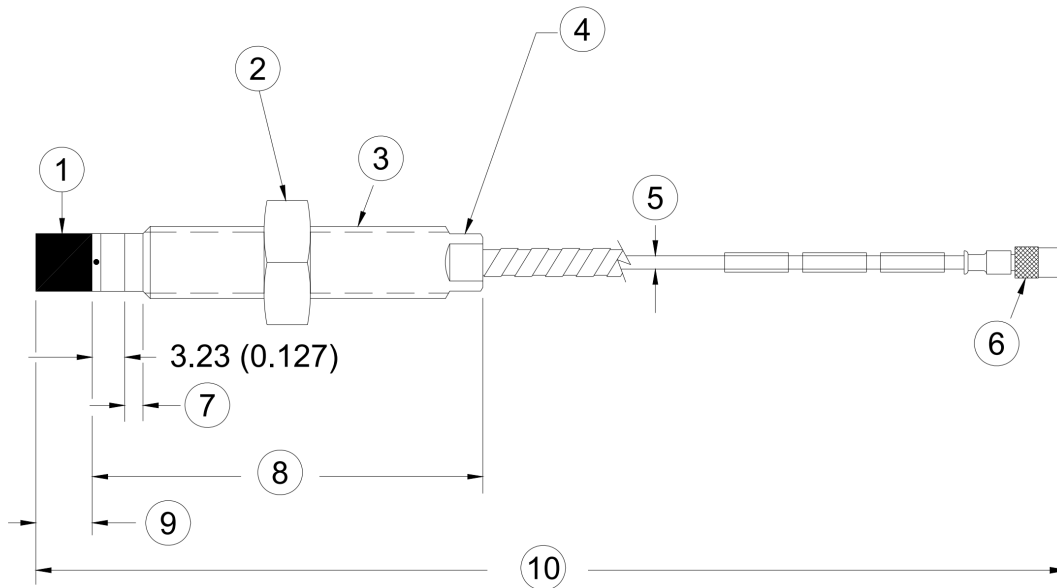

1. Probe tip, 5.26 mm (0.207 in) maximum diameter
2. Hexagonal nut
3. Case Thread
4. Wrench flats
5. 75Ω cable, 2.8 mm (0.11 in) maximum outside diameter, 7.6 mm (0.30 in) maximum outside diameter of armor
6. Miniature male coaxial connector, 7.23 mm (0.285 in) maximum outside diameter "D"
7. Unthreaded length "A"
8. Case length "B"
9. 2.92 mm (0.115 in) maximum
10. Total length "C", +30%, -0%

Figure 3: 3300 NSv Proximity Probes, Standard Mount

- 330901, 1/4-28 UNF-2A, without armor
- 330902, 1/4-28 UNF-2A, with armor
- 330903, M8x1 thread, without armor
- 330904, M8x1 thread, with armor
- 330905, M10x1 thread, without armor
- 330908, 3/8-24 UNF-2A, without armor
- 330909, 3/8-24 UNF-2A, with armor
- 330910, M10x1 thread, with armor



Standard mount 1/4-28 UNF thread probes are supplied with a 7/16 inch lock nut and 7/32 inch wrench flats. Standard mount M8x1 thread probes are supplied with a 13 mm lock nut and 7 mm wrench flats. Standard mount 3/8-28 UNF thread probes are supplied with a 9/16 inch lock nut and 5/16 inch wrench flats. Standard mount M10x1 thread probes are supplied with a 17 mm lock nut and 8 mm wrench flats.

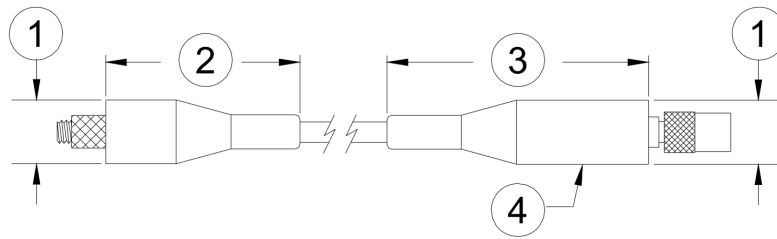

1. 12 mm (0.49 in) maximum diameter
2. 36.3 mm (1.43 in) maximum
3. 51.1 mm (2.01 in) maximum
4. Connector protector (fluorosilicone material)

Figure 4: Installed Connector Protectors

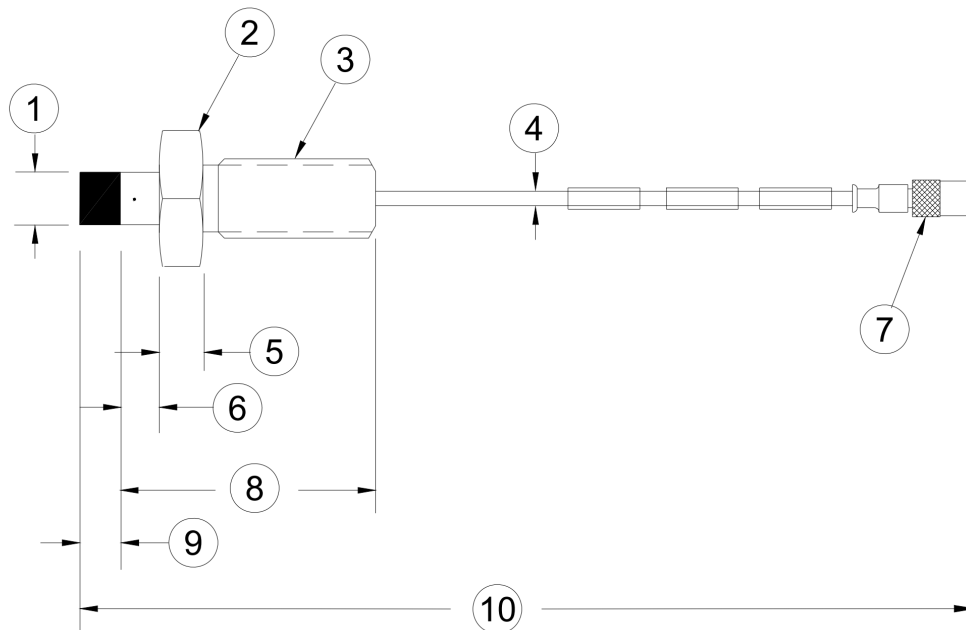

1. Probe tip, 5.26 mm (0.207 in) maximum diameter
2. Hexagonal nut
3. Case thread
4. 75Ω cable, 2.8 mm (0.11 in) outside diameter
5. Miniature male coaxial connector, 7.23 mm (0.285 in) maximum outside diameter "D"
6. 5.08 mm (0.20 in)
7. Unthreaded case length "A", 5.08 mm (0.20 in)
8. Case length "B", 30.48 mm (1.20 in)
9. 2.92 mm (0.115 in) maximum
10. Total length "C", +30%, -0%

Figure 5: 3300 NSv Proximity Probes, Reverse Mount

330906, 3/8-24 UNF-2A
330907, M10x1 thread



Reverse mount probes are not available with armor or connector protector options.

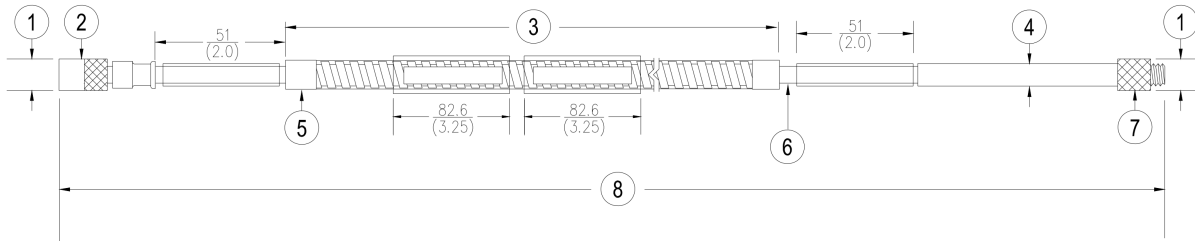

1. 7.2 mm (0.285 in) maximum diameter
2. Miniature male coaxial connector
3. FEP-coated or uncoated armor, armor length is 300 mm (11.8 in) less than cable length
4. 75Ω cable, 2.80 mm (0.11 in) maximum outside diameter, 7.6 mm (0.30 in) maximum outside diameter of armor, 7.0 mm (0.275 in) maximum outside diameter of uncoated armor
5. Stainless steel ferrules, 8.4 mm (0.33 in) diameter
6. FEP-insulated coaxial cable
7. Miniature female coaxial connector
8. Cable length +20%, -0%

Figure 6: 3300 NSv Extension Cable

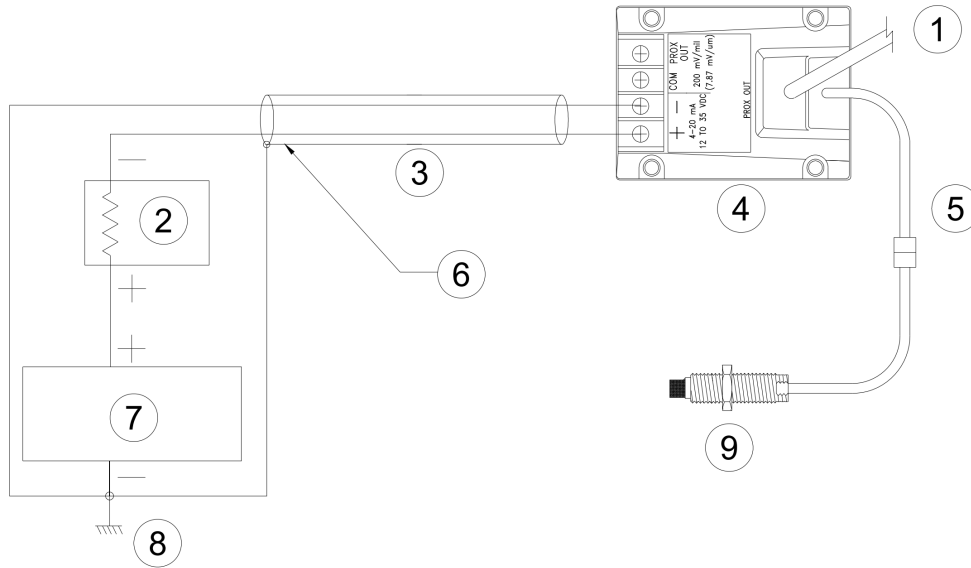

1. To test adapter 122115-01
2. Receiver
3. Cable shield
4. Transmitter
5. Extension cable
6. Recommended wiring is shielded, twisted-pair, 1.0 mm (18 AWG) (part number 02173006). Maximum length is 13 km (8 miles).
7. Power supply, $V_{PS} = 17$ to 35 Vdc
8. Common (ground)
9. Probe

Figure 7: 991 Thrust Transmitter Loop Wiring Connections



The phase of the PROX OUT signal is inverted from the standard for Bently Nevada products. Also, connecting grounded ac-powered equipment to PROX OUT may result in a false alarm. Use test adapter 122115-01 to connect ac equipment to the transmitter. Note that the 122115-01 also inverts the PROX OUT signal.

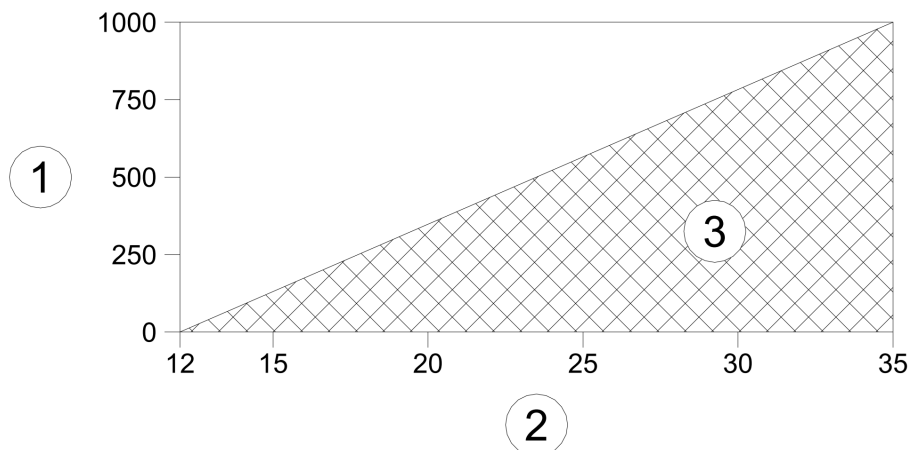

1. Maximum loop resistance in ohms (R_{LOOP})
2. Power supply voltage (V_{PS})
3. Operating region

Figure 8: 991 Thrust Transmitter Maximum Loop Resistance



$R_{LOOP} = 43.5 \times (V_{PS} - 12)$ W maximum. If the maximum loop resistance is exceeded, then the full scale current will not reach 20 mA.

Copyright 2020 Baker Hughes Company. All rights reserved.



Bently Nevada, Orbit Logo, System 1 and Proximitor are registered trademarks of Bently Nevada, a Baker Hughes Business, in the United States and other countries. The Baker Hughes logo is a trademark of Baker Hughes Company. All other product and company names are trademarks of their respective holders. Use of the trademarks does not imply any affiliation with or endorsement by the respective holders.

Baker Hughes provides this information on an "as is" basis for general information purposes. Baker Hughes does not make any representation as to the accuracy or completeness of the information and makes no warranties of any kind, specific, implied or oral, to the fullest extent permissible by law, including those of merchantability and fitness for a particular purpose or use. Baker Hughes hereby disclaims any and all liability for any direct, indirect, consequential or special damages, claims for lost profits, or third party claims arising from the use of the information, whether a claim is asserted in contract, tort, or otherwise. Baker Hughes reserves the right to make changes in specifications and features shown herein, or discontinue the product described at any time without notice or obligation. Contact your Baker Hughes representative for the most current information.

The information contained in this document is the property of Baker Hughes and its affiliates; and is subject to change without prior notice. It is being supplied as a service to our customers and may not be altered or its content repackaged without the express written consent of Baker Hughes. This product or associated products may be covered by one or more patents. See [Bently.com/legal](https://www.bently.com/legal).

1631 Bently Parkway South, Minden, Nevada USA 89423
Phone: 1.775.782.3611 or 1.800.227.5514 (US only)
[Bently.com](https://www.bently.com)