



Level



Pressure



Flow



Temperature



Liquid
Analysis



Registration



Systems
Components



Services



Solutions

Operating Instructions

Proline Prosonic Flow 93 HART

Ultrasonic flow measuring system

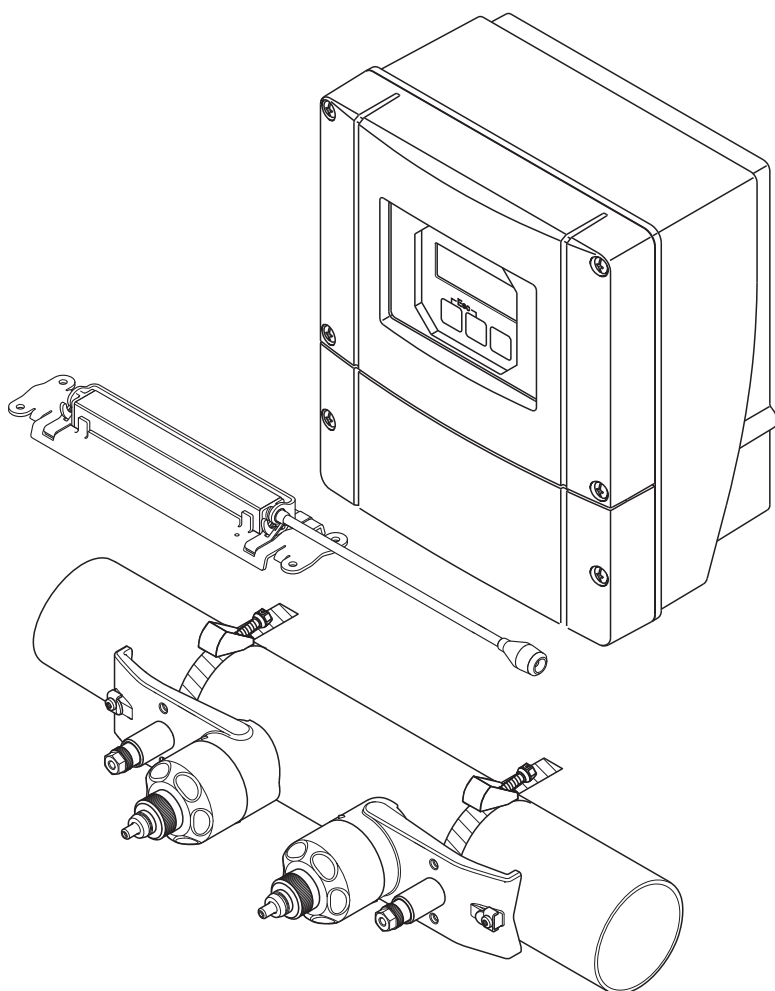

BA00070D/06/EN/13.11
71134382

Valid as of version
V 2.02.XX (Device software)

Table of contents

1	Safety instructions	5		
1.1	Designated use	5		
1.2	Installation, commissioning and operation	5		
1.3	Operational safety	5		
1.4	Return	6		
1.5	Notes on safety conventions and icons	6		
2	Identification	7		
2.1	Device designation	7		
2.1.1	Nameplate of the transmitter	7		
2.1.2	Nameplate of the sensor	8		
2.1.3	Nameplate for the connections	9		
2.2	Certificates and approvals	10		
2.3	Registered trademarks	10		
3	Installation	11		
3.1	Incoming acceptance, transport and storage	11		
3.1.1	Incoming acceptance	11		
3.1.2	Transport	11		
3.1.3	Storage	11		
3.2	Installation conditions	11		
3.2.1	Dimensions	11		
3.2.2	Mounting location	11		
3.2.3	Orientation	12		
3.2.4	Inlet and outlet run	12		
3.2.5	Sensor selection and arrangement	13		
3.3	Two-channel operation	14		
3.3.1	Two-channel measurement	14		
3.3.2	Two-path measurement	15		
3.4	Preparatory steps prior to installation	16		
3.5	Determining the necessary installation distances	16		
3.5.1	Installation distances for Prosonic Flow P or W clamp-on	16		
3.5.2	Installation distances for Prosonic Flow W Insertion	16		
3.6	Determining values for installation distances	17		
3.6.1	Determining installation distances via local operation	17		
3.6.2	Determining installation distances via FieldCare	22		
3.6.3	Determining installation distances via Applicator	28		
3.7	Mechanical preparation	30		
3.7.1	Mounting the sensor holder with U-shaped screws	30		
3.7.2	Mounting the sensor holder with strapping bands	31		
3.7.3	Premounting the strapping bands (medium nominal diameters)	32		
3.7.4	Premounting the strapping bands (large nominal diameters)	33		
3.7.5	Mounting the welded bolts	34		
3.8	Installing Prosonic Flow W and P (DN 15 to 65 / ½ to 2½")	35		
	3.8.1 Mounting the sensor	35		
3.9	Installing Prosonic Flow P DN 50 to 4000 (2 to 160") (Clamp-on)	37		
	3.9.1 Installation for measurement via one traverse	37		
	3.9.2 Installation for measurement via two traverses	39		
3.10	Installing Prosonic Flow W (Clamp-on)	41		
	3.10.1 Installation for measurement via one traverse	41		
	3.10.2 Installation for measurement via two traverses	43		
3.11	Installing Prosonic Flow W (Insertion version)	45		
	3.11.1 Installation for measurement as single-path insertion version	46		
	3.11.2 Installation for measurement as dual-path insertion version	49		
3.12	Installing sensor DDU18	53		
3.13	Installing sensor DDU19	54		
	3.13.1 Version 1	54		
	3.13.2 Version 2	54		
3.14	Installing the wall-mount transmitter housing	55		
	3.14.1 Direct wall mounting	55		
	3.14.2 Panel mounting	56		
	3.14.3 Pipe mounting	56		
3.15	Post-installation check	57		
4	Wiring	58		
4.1	Sensor/transmitter connecting cable	58		
	4.1.1 Connecting and grounding Prosonic Flow W and P (DN 50 to 4000 / 2 to 160") Two Single coaxial cables	58		
	4.1.2 Connecting and Grounding Prosonic Flow W and Prosonic Flow P DN 15 to 65 (½ to 2½") Multicore cable	60		
	4.1.3 Cable specification for connecting cable	61		
4.2	Connecting the measuring unit	61		
	4.2.1 Connecting the transmitter	61		
	4.2.2 Terminal assignment	62		
	4.2.3 HART connection	63		
4.3	Potential equalization	64		
4.4	Degree of protection	64		
4.5	Post-connection check	65		
5	Operation	66		
5.1	Quick operation guide	66		
5.2	Display and operating elements	66		
5.3	Brief guide to the function matrix	69		
	5.3.1 General notes	70		
	5.3.2 Enabling the programming mode	70		
	5.3.3 Disabling the programming mode	70		
5.4	Error messages	71		
	5.4.1 Type of error	71		
	5.4.2 Error message types	71		
	5.4.3 Confirming error messages	72		

5.5 Communication (HART) 72

5.5.1 Operating options 73

5.5.2 Current device description files 74

5.5.3 Device variables and process variables 74

5.5.4 Universal/common practice
HART commands 75

5.5.5 Device status/error messages 80

6 Commissioning 83

6.1 Function check 83

6.2 Commissioning via onsite display 84

6.2.1 Quick Setup "Sensor Installation" 84

6.2.2 Quick Setup "Commissioning" 85

6.2.3 Quick Setup "Pulsating Flow" 88

6.3 Application-specific commissioning 91

6.3.1 Zero point adjustment 91

6.3.2 Advanced diagnostic functions 93

6.3.3 Data storage with "T-DAT SAVE/LOAD" .. 95

6.4 Hardware settings 96

6.4.1 Switching HART write protection on/off .. 96

6.4.2 Current output: active/passive 97

6.4.3 Relay contacts: NC contact/NO contact .. 98

6.5 Data storage device (HistoROM, F-CHIP) 99

6.5.1 HistoROM/T-DAT (transmitter-DAT) 99

6.5.2 F-CHIP (function chip) 99

7 Maintenance 100

8 Accessories 101

9 Troubleshooting 105

9.1 Troubleshooting instructions 105

9.2 System error messages 106

9.3 Process error messages 110

9.4 Process errors without messages 111

9.5 Response of outputs to errors 112

9.6 Spare parts 113

9.7 Installing and removing electronics boards 114

9.8 Installing and removing the W sensors 116

9.9 Replacing the device fuse 117

9.10 Return 117

9.11 Disposal 117

9.12 Software history 118

10 Technical data 119

10.1 Quick technical data guide 119

10.1.1 Application 119

10.1.2 Function and system design 119

10.1.3 Input 119

10.1.4 Output 120

10.1.5 Power supply 122

10.1.6 Performance characteristics 123

10.1.7 Operating conditions: installation 125

10.1.8 Operating conditions: environment 125

10.1.9 Operating conditions: process 126

10.1.10 Mechanical construction 127

10.1.11 Human interface 129

10.1.12 Certificates and approvals 130

10.1.13 Accessories 130

10.1.14 Ordering information 130

10.1.15 Documentation 130

Index 131

1 Safety instructions

1.1 Designated use

The measuring device described in these Operating Instructions is to be used only for measuring the flow rate of liquids in closed pipes.

Examples:

- Acids, alkalis, paints, oils
- Liquid gas
- Ultrapure water with low conductivity, water, wastewater

As well as measuring the volume flow, the sound velocity of the fluid is also always measured. Different fluids can be distinguished or the fluid quality can be monitored.

Resulting from incorrect use or from use other than that designated the operational safety of the measuring devices can be suspended. The manufacturer accepts no liability for damages being produced from this.



1.2 Installation, commissioning and operation

Note the following points:

- Installation, connection to the electricity supply, commissioning and maintenance of the device must be carried out by trained, qualified specialists authorized to perform such work by the facility's owner-operator.
The specialist must have read and understood these Operating Instructions and must follow the instructions they contain.
- The device must be operated by persons authorized and trained by the facility's owner-operator. Strict compliance with the instructions in these Operating Instructions is mandatory.
- Endress+Hauser is willing to assist in clarifying the chemical resistance properties of parts wetted by special fluids, including fluids used for cleaning.
However, small changes in temperature, concentration or the degree of contamination in the process can result in changes to the corrosion resistance properties. Therefore, Endress+Hauser cannot guarantee or accept liability for the corrosion resistance properties of wetted materials in a specific application.
The user is responsible for choosing suitable wetted materials in the process.
- If carrying out welding work on the piping, the welding unit may not be grounded by means of the measuring device.
- The installer must ensure that the measuring system is correctly wired in accordance with the wiring diagrams. The transmitter must be grounded, except in cases where special protective measures have been taken (e.g. galvanically isolated power supply SELV or PELV).
- Invariably, local regulations governing the opening and repair of electrical devices apply.

1.3 Operational safety

Note the following points:

- Measuring systems for use in hazardous environments are accompanied by separate "Ex documentation", which is an integral part of these Operating Instructions. Strict compliance with the installation instructions and ratings as stated in this supplementary documentation is mandatory. The symbol on the front of this supplementary Ex documentation indicates the approval and inspection authority (e.g.  Europe,  USA,  Canada).
- The measuring system complies with the general safety requirements in accordance with EN 61010-1, the EMC requirements of IEC/EN 61326, and NAMUR Recommendation NE 21 and NE 43.
- The manufacturer reserves the right to modify technical data without prior notice. Your Endress+Hauser distributor will supply you with current information and updates to this Operating Instructions.

1.4 Return

The following procedures must be carried out before a flowmeter requiring repair or calibration, for example, is returned to Endress+Hauser:

- Always enclose a duly completed "Declaration of Contamination" form. Only then can Endress+Hauser transport, examine and repair a returned device.



Note!

You will find a preprinted "Declaration of Contamination" form at the back of this manual.

- Enclose special handling instructions if necessary, for example a safety data sheet as per Regulation (EC) No 1907/2006 REACH.
- Remove all residues. Pay special attention to the grooves for seals and crevices which could contain residues. This is particularly important if the substance is hazardous to health, e.g. flammable, toxic, caustic, carcinogenic, etc.



Warning!

- Do not return a measuring device if you are not absolutely certain that all traces of hazardous substances have been removed, e.g. substances which have penetrated crevices or diffused through plastic.
- Costs incurred for waste disposal or injury (burns, etc.) due to inadequate cleaning will be charged to the owner-operator.

1.5 Notes on safety conventions and icons

The devices are designed and tested to meet state-of-the-art safety requirements, and have left the factory in a condition in which they are safe to operate. The devices comply with the applicable standards and regulations in accordance with EN 61010 -1 "Protection Measures for Electrical Equipment for Measurement, Control, Regulation and Laboratory Procedures". The devices can, however, be a source of danger if used incorrectly or for other than the designated use. For this reason, always pay particular attention to the safety instructions indicated in these Operating Instructions by the following icons:



Warning!

"Warning" indicates an action or procedure which, if not performed correctly, can result in personal injury or a safety hazard. Comply strictly with the instructions and proceed with care.



Caution!

"Caution" indicates an action or procedure which, if not performed correctly, can result in incorrect operation or destruction of the device. Comply strictly with the instructions.



Note!

"Note" indicates an action or procedure which, if not performed correctly, can have an indirect effect on operation or trigger an unexpected response on the part of the device.

2 Identification

2.1 Device designation

The "Prosonic Flow 93" flowmeter system consists of the following components:

- Prosonic Flow 93 transmitter
- Sensor:
 - Prosonic Flow P Clamp-on version (DN 15 to 65 / ½ to 2½")
 - Prosonic Flow P Clamp-on version (DN 50 to 4000 / 2 to 160")
 - Prosonic Flow W Clamp-on version (DN 15 to 65 / ½ to 2½")
 - Prosonic Flow W Clamp-on version (DN 50 to 4000 / 2 to 160")
 - Prosonic Flow W Insertion version

The transmitter and sensor are mounted separately from one another and connected by a connecting cable.

2.1.1 Nameplate of the transmitter

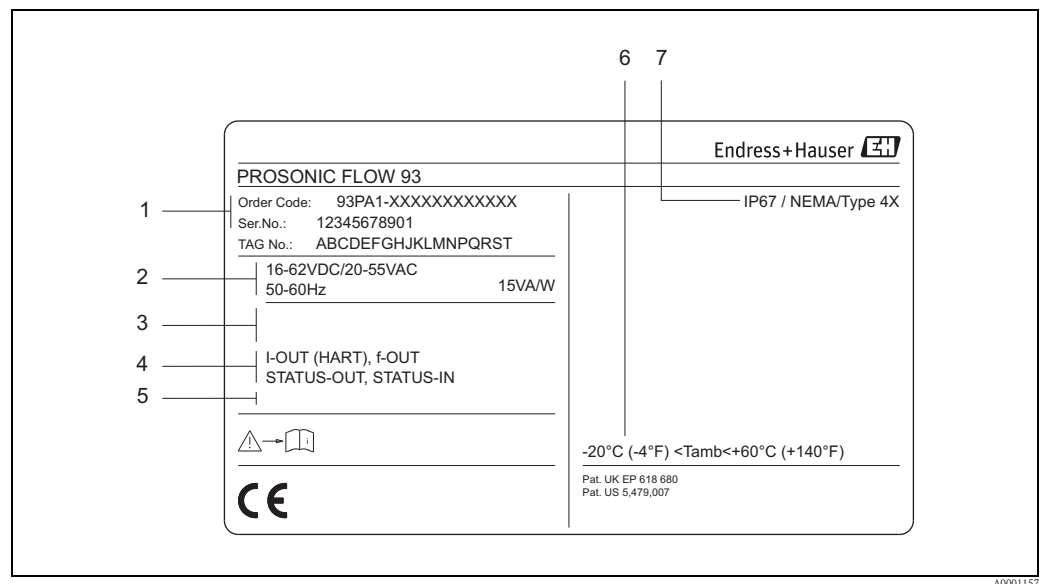

Fig. 1: Nameplate specifications for the "Prosonic Flow 93" transmitter (example)

- 1 Order code/serial number: See the specifications on the order confirmation for the meanings of the individual letters and digits
- 2 Power supply/frequency: 16 to 62 V DC / 20 to 55 V AC / 50 to 60 Hz
Power consumption: 15 VA / W
- 3 Reserved for additional information
- 4 Available inputs and outputs:
I-OUT (HART): with current output (HART)
f-OUT: with pulse/frequency output
RELAY: with relay output
STAT-IN: with status input (auxiliary input)
- 5 Reserved for information on special products
- 6 Permitted ambient temperature range
- 7 Degree of protection

2.1.2 Nameplate of the sensor

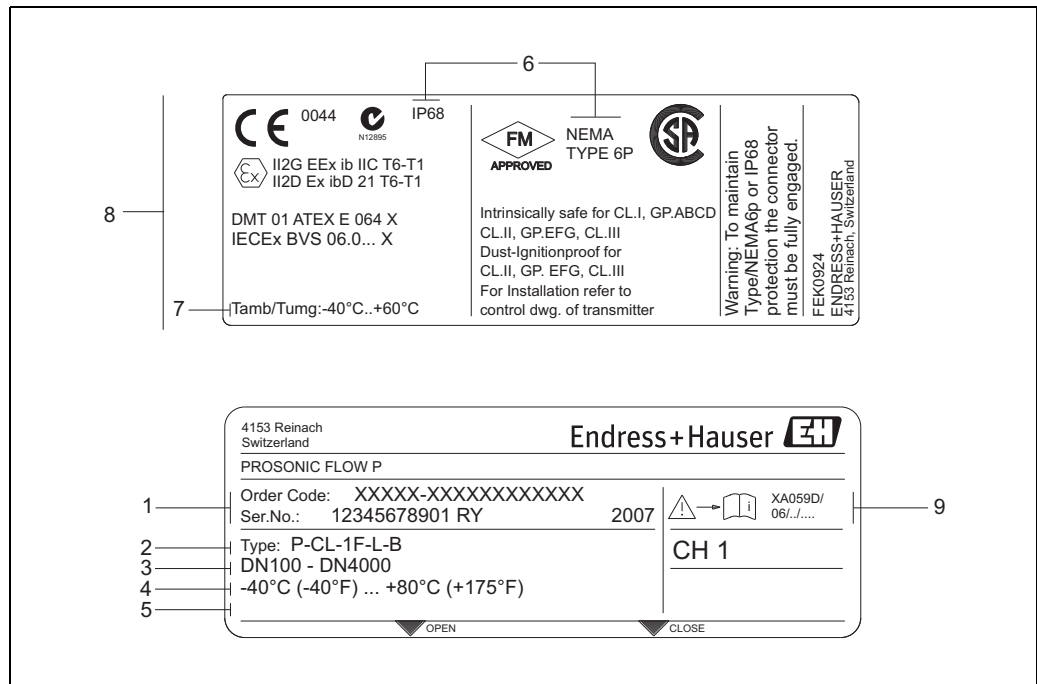

Fig. 2: Nameplate specifications for the "Prosonic Flow P" sensor (example)

- 1 Order code/serial number: See the specifications on the order confirmation for the meanings of the individual letters and digits.
- 2 Sensor type
- 3 Range of nominal diameter: DN 100 to 4000 (4 to 160")
- 4 Max. fluid temperature range: -40 to +80 °C (-40 to +175 °F)
- 5 Reserved for information on special products
- 6 Degree of protection
- 7 Permitted ambient temperature range
- 8 Data on explosion protection
Refer to the specific additional Ex documentation for detailed information.
Please do not hesitate to contact your Endress+Hauser sales office if you have any questions.

2.1.3 Nameplate for the connections

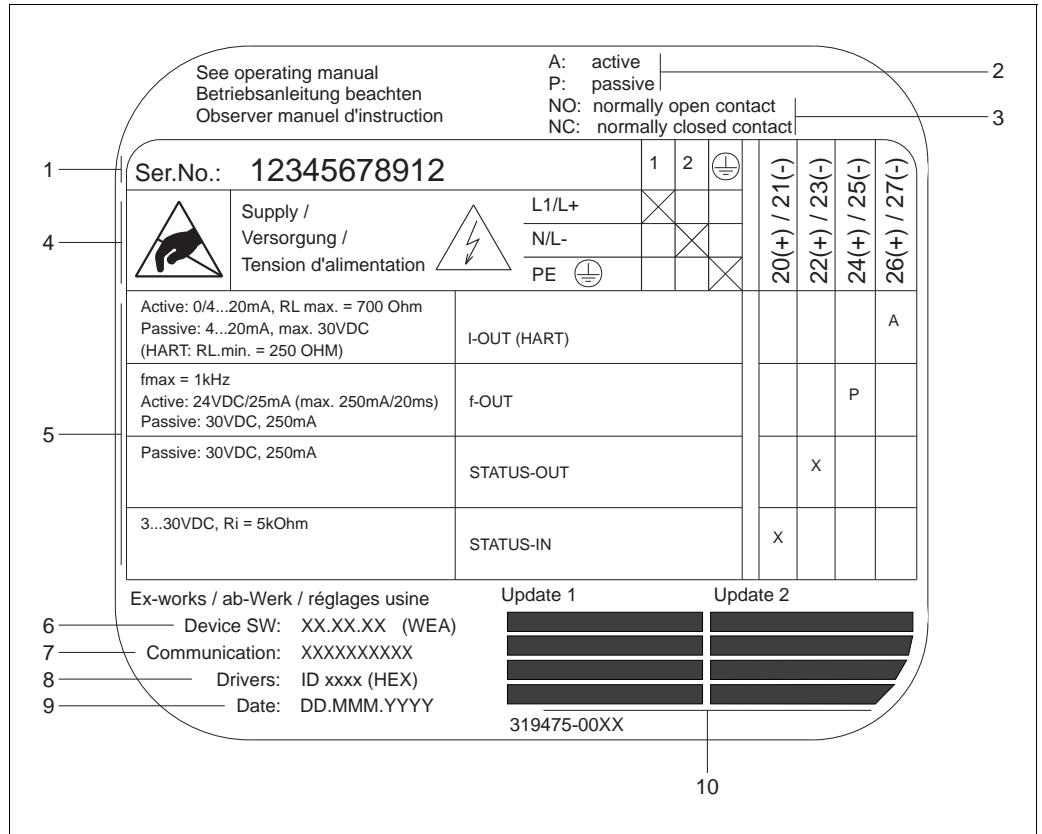

Fig. 3: Nameplate specifications for Proline transmitter (example)

- 1 Serial number
- 2 Possible configuration of the current input
- 3 Possible configuration of the relay contacts
- 4 Terminal assignment, cable for power supply: 85 to 260 V AC, 20 to 55 V AC, 16 to 62 V DC
Terminal No. 1: L1 for AC, L+ for DC
Terminal No. 2: N for AC, L- for DC
- 5 Signals present at the inputs and outputs, possible configurations and terminal assignment (20 to 27), see also "Electrical values of the inputs/outputs"
- 6 Version of device software currently installed
- 7 Installed communication mode e.g.: HART, PROFIBUS PA, etc.
- 8 Information on current communication software (Device Revision and Device Description), e.g.: Dev. 01 / DD 01 for HART
- 9 Date of installation
- 10 Current updates to the information listed in Points 6 to 9

2.2 Certificates and approvals

The devices are designed in accordance with good engineering practice to meet state-of-the-art safety requirements, have been tested, and left the factory in a condition in which they are safe to operate.

The devices comply with the applicable standards and regulations in accordance with EN 61010-1 "Safety requirements for electrical equipment for measurement, control and laboratory use" and with the EMC requirements of IEC/EN 61326.

The measuring system described in these Operating Instructions thus complies with the statutory requirements of the EC Directives. Endress+Hauser confirms successful testing of the device by affixing to it the CE mark.

The measuring system complies with the EMC requirements of the "Australian Communications and Media Authority (ACMA)".

2.3 Registered trademarks

HART®

Registered trademark of HART Communication Foundation, Austin, USA

HistoROM™, T-DAT™, F-CHIP®, FieldCare®, Fieldcheck®, FieldXpert™, Applicator®

Registered or registration-pending trademarks of Endress+Hauser Flowtec AG, Reinach, CH

3 Installation

3.1 Incoming acceptance, transport and storage

3.1.1 Incoming acceptance

On receipt of the goods, check the following points:

- Check the packaging and the contents for damage.
- Check the shipment, make sure nothing is missing and that the scope of supply matches your order.

3.1.2 Transport

The devices must be transported in the container supplied when transporting them to the measuring point.

3.1.3 Storage

- Pack the measuring device in such a way as to protect it reliably against impact for storage (and transportation). The original packaging provides optimum protection.
- The storage temperature corresponds to the ambient temperature range of the transmitter, the sensors and the corresponding sensor cables (→ [119](#)).
- The measuring device must be protected against direct sunlight during storage in order to avoid unacceptably high surface temperatures.

3.2 Installation conditions

3.2.1 Dimensions

The dimensions and lengths of the sensor and transmitter are provided in the separate "Technical Information" document on the device in question. This can be downloaded as a PDF file from www.endress.com.

A list of the "Technical Information" documents available is provided on → [130](#).

3.2.2 Mounting location

Correct flow measurement is possible only if a pipe is full. Entrained air or gas bubbles forming in the pipe can result in an increase in measuring errors.

Avoid the following locations in the pipe installation:

- Highest point of a pipeline. Risk of air accumulating.
- Directly upstream of a free pipe outlet in a vertical pipeline.

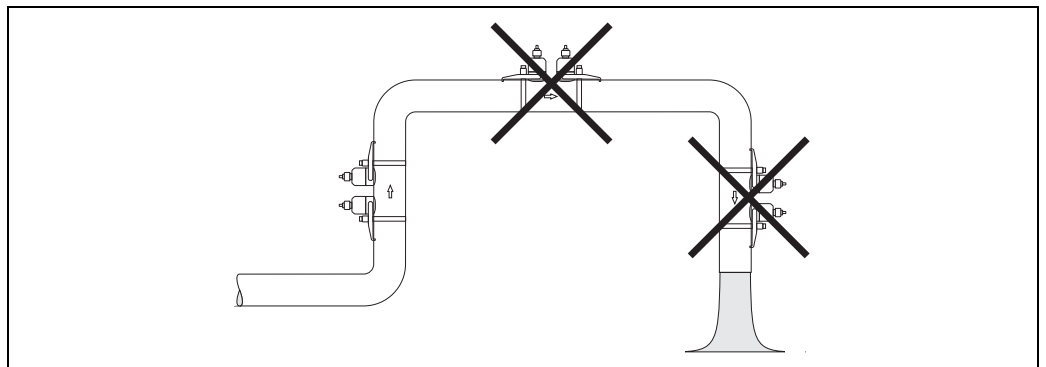

Fig. 4: Mounting location

A0001103

3.2.3 Orientation

Vertical orientation

We recommend the sensor be mounted where there is upward direction of flow. With this orientation, entrained solids will sink down and gases will rise away from the sensor when the fluid is stagnant.

Horizontal orientation

We recommend the sensors be mounted within an angle of $\pm 60^\circ$ to the horizontal (area shaded gray in the graphic). With this orientation, flow measurement is less affected by any gas or air accumulation in the upper area of the pipe or by buildup at the bottom of the pipe.

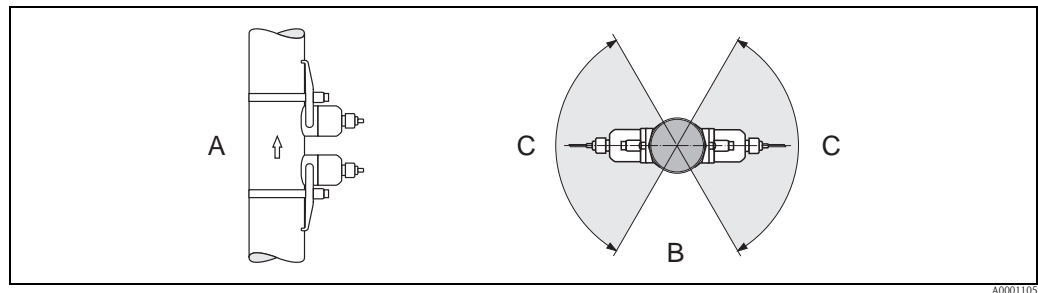

Fig. 5: Recommended orientation and recommended installation range

- A Vertical: Recommended installation with vertical/upward direction of flow
- B Horizontal: Recommended installation range with horizontal orientation
- C Recommended installation range max. 120°

3.2.4 Inlet and outlet run

If possible, install the sensor well clear of assemblies such as valves, T-pieces, elbows, etc. If several flow obstructions are installed, the longest inlet or outlet run must be considered. Compliance with the following inlet and outlet runs is required in order to ensure measuring accuracy.

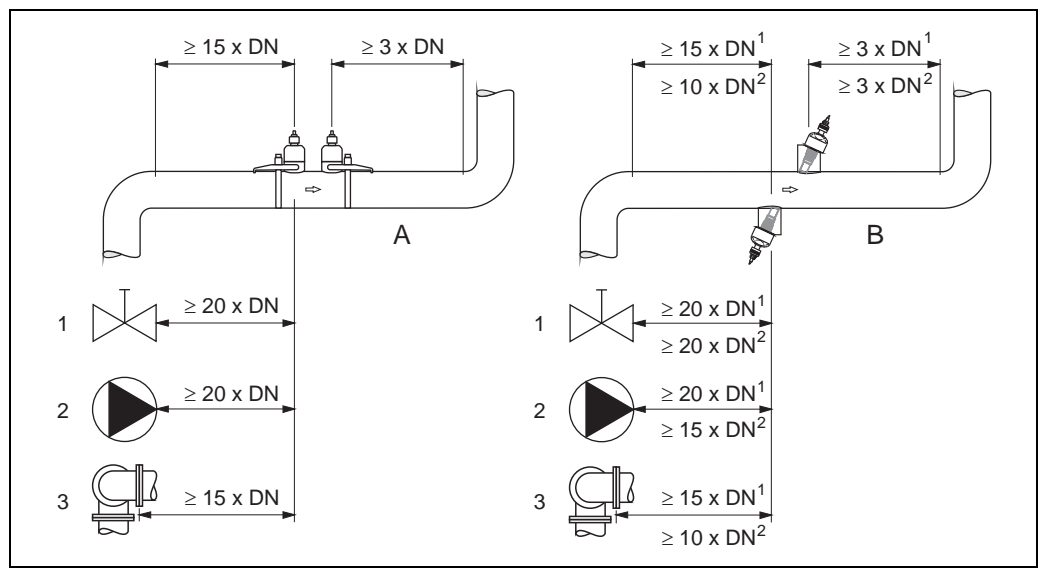

Fig. 6: Recommended inlet and outlet runs to comply with measuring accuracy specifications

- A Clamp-on version
- B Insertion version
- ¹ = values for single-path version
- ² = values for two-path version
- 1 Valve (2/3 open)
- 2 Pump
- 3 Two pipe bends in different directions

3.2.5 Sensor selection and arrangement

The sensors can be arranged in two ways:

- Mounting arrangement for measurement via one traverse: the sensors are located on opposite sides of the pipe.
- Mounting arrangement for measurement via two traverses: the sensors are located on the same side of the pipe.

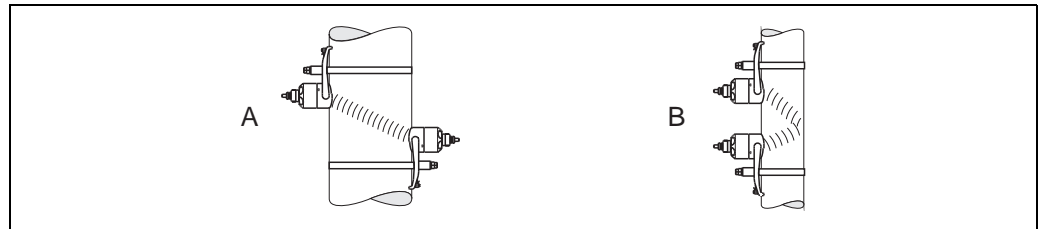

Fig. 7: Sensor mounting arrangement (top view)

- A Mounting arrangement for measurement via one traverse
 B Mounting arrangement for measurement via two traverses

The number of traverses required depends on the sensor type, the nominal diameter and the thickness of the pipe wall. We recommend the following types of mounting:

Sensor Type	Nominal Diameter	Sensor Frequency	Sensor ID	Type of Mounting ¹⁾
Prosonic Flow P	DN 15 to 65 (½ to 2½")	6 MHz	P-CL-6F*	2 traverses ⁵⁾
	DN 50 to 65 (2 to 2½")	2 MHz	P-CL-6F* P-CL-2F*	2 (or 1) traverses
	DN 80 (3")	2 MHz	P-CL-2F*	2 traverses
	DN 100 to 300 (4 to 12")	2 MHz (or 1 MHz)	P-CL-2F* P-CL-1F*	2 traverses
	DN 300 to 600 (12 to 24")	1 MHz (or 2 MHz)	P-CL-1F* P-CL-2F*	2 traverses
	DN 650 to 4000 (26 to 160")	1 MHz	P-CL-1F*	1 traverse
Prosonic Flow W	DN 15 to 65 (½ to 2½")	6 MHz	W-CL-6F*	2 traverses ⁵⁾
	DN 50 to 65 (2 to 2½")	2 MHz	W-CL-2F*	2 (or 1) traverses ²⁾
	DN 80 (3")	2 MHz	W-CL-2F*	2 traverses
	DN 100 to 300 (4 to 12")	2 MHz (or 1 MHz)	W-CL-2F* W-CL-1F*	2 traverses ³⁾
	DN 300 to 600 (12 to 24")	1 MHz (or 2 MHz)	W-CL-1F* W-CL-2F*	2 traverses ³⁾
	DN 650 to 4000 (26 to 160")	1 MHz (or 0.5 MHz)	W-CL-1F* W-CL-05F*	1 traverse ³⁾

¹⁾ The installation of clamp-on sensors is principally recommended in the 2 traverse type installation. This type of installation allows the easiest and most comfortable type of mounting and means that a system can also be mounted even if the pipe can only be accessed from one side. However, in certain applications a 1 traverse installation may be preferred. These include:

- Certain plastic pipes with wall thickness > 4 mm (0.16")
- Pipes made of composite materials such as GRP
- Lined pipes
- Applications with fluids with high acoustic damping

²⁾ If the pipe nominal diameter is small (DN 65 / 2½" and smaller), the sensor spacing with Prosonic Flow W can be too small for two traverse installation. In this case, the 1 traverse type of installation must be used.

³⁾ 0.5 MHz sensors are also recommended for applications with composite material pipes such as GRP and may be recommended for certain lined pipes, pipes with wall thickness > 10 mm (0.4"), or applications with media with high acoustic damping. In addition, for these applications we principally recommend mounting the W sensors in a 1 traverse configuration.

⁴⁾ Insertion W sensors are mounted in a 1 traverse configuration → 45.

⁵⁾ 6 MHz sensors for applications where flow velocity ≤ 10m/s (32.8Hz/s)

3.3 Two-channel operation

The transmitter is able to operate two independent measuring channels (measuring channel 1 and measuring channel 2). A pair of sensors is connected per measuring channel. Both measuring channels operate independently of one another and are supported by the transmitter to an equal extent.

Two-channel operation can be used for the following measurements:

- Two-channel measurement = flow measurement at two separate measuring points
- Two-path measurement = redundant flow measurement at one measuring point

3.3.1 Two-channel measurement

The flow is measured at two separate measuring points in the case of two-channel measurement.

The measured values of the two measuring channels can be processed and displayed differently.

The following measured values can be output for two-channel measurement:

- Individual measured values per measuring channel (output independently of one another)
- The difference between the two measured values
- The sum of the two measured values

The two measuring channels can be configured individually. This makes it possible to independently configure and select the display, outputs, sensor type and type of installation.

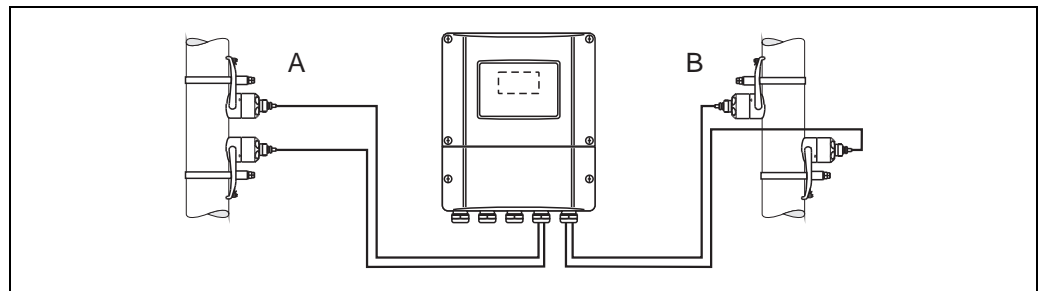

A0001159

Fig. 8: Two-channel measurement: example of arranging sensor pairs at two separate measuring points

- A Measuring channel 1: mounting the sensor pair for measurement via two traverses
 B Measuring channel 2: mounting the sensor pair for measurement via one traverse

3.3.2 Two-path measurement

The flow is measured redundantly at one measuring point in the case of two-path measurement.

The measured values of the two measuring channels can be processed and displayed differently. The following measured values can be output for two-path measurement:

- Individual measured values per measuring channel (output independently of one another)
- The average of the two measured values.

The "Averaging" function generally provides you with a more stable measured value. The function is thus suitable for measurements under conditions that are not ideal (e.g. short inlet runs).

The two measuring channels can be configured individually. This makes it possible to independently configure and select the display, outputs, sensor type and type of installation.

It is generally not necessary to individually configure the two measuring channels in the case of two-path measurement. However, in certain situations individual channel configuration can be used to balance out application-specific asymmetries.

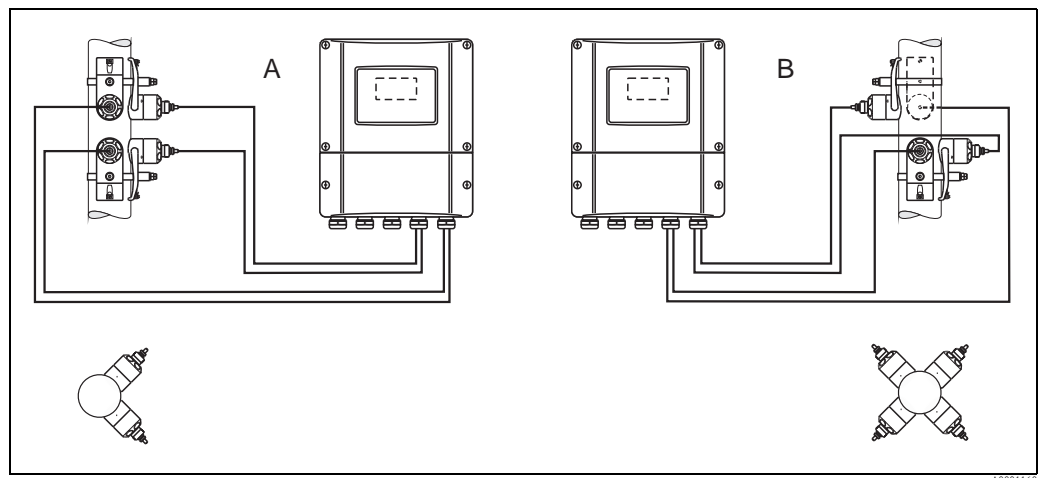

Fig. 9: Two-path measurement: examples of arranging sensor pairs at one measuring point

- A Measuring channel 1 and measuring channel 2: mounting the two sensor pairs for one measurement per pair via two traverses
- B Measuring channel 1 and measuring channel 2: mounting the two sensor pairs for one measurement per pair via one traverse

3.4 Preparatory steps prior to installation

Depending on the conditions specific to the measuring point (e.g. clamp-on, number of traverses, fluid, etc.), a number of preparatory steps have to be taken before actually installing the sensors:

1. Determination of the values for the necessary installation distances based on the conditions specific to the measuring point. A number of methods are available for determining the values:
 - Local operation of the device
 - FieldCare (operating program), connect a notebook to the transmitter
 - Applicator (software), online on the Endress+Hauser Internet site
2. Mechanical preparation of the clamp-on retainers for the sensors:
 - Premount the strapping bands (DN 50 to 200 / 2 to 8") or (DN 250 to 4000 / 10 to 160")
 - Fix the welded bolts

3.5 Determining the necessary installation distances

The installation distances that have to be maintained depend on:

- The type of sensor: P or W (DN 50 to 4000 / 2 to 160"), P or W (DN 15 to 65 / ½ to 2½")
- Type of mounting:
 - Clamp-on with strapping band or welded bolt
 - Insertion version, installation in the pipe
- Number of traverses or single-path/dual-path version

3.5.1 Installation distances for Prosonic Flow P or W clamp-on

DN 50 to 4000 (2 to 160")				DN 15 to 65 (½ to 2½")
Clamp-on Strapping band		Clamp-on Welded bolts		Clamp-on Strapping band
1 traverse	2 traverses	1 traverse	2 traverses	2 traverses
SENSOR DISTANCE	SENSOR DISTANCE	SENSOR DISTANCE	SENSOR DISTANCE	SENSOR DISTANCE
WIRE LENGTH	POSITION SENSOR	WIRE LENGTH	POSITION SENSOR	–

3.5.2 Installation distances for Prosonic Flow W Insertion

DN 200 to 4000 (8 to 160")	
Insertion version	
Single-path	Dual-path
SENSOR DISTANCE	SENSOR DISTANCE
PATH LENGTH	ARC LENGTH

3.6 Determining values for installation distances

3.6.1 Determining installation distances via local operation

Perform the following steps to determine the installation distances:

1. Mount the wall-mount housing.
2. Connect the power supply.
3. Switch on the measuring device.
4. Run the "Sensor Installation" Quick Setup menu.

Installing the wall-mount transmitter housing

There are various ways of installing the wall-mount housing:

- Direct wall mounting
- Panel mounting (with separate mounting kit, accessories) → [101](#)
- Pipe mounting (with separate mounting kit, accessories) → [101](#)



Caution!

- Make sure that the permitted operating temperature range (-20 to $+60$ °C / -4 to $+140$ °F) is not exceeded at the mounting location. Install the device in a shady location. Avoid direct sunlight.
- Always install the wall-mount housing in such a way that the cable entries are pointing down.

Direct wall mounting

1. Drill the holes → [17](#).
2. Remove the cover of the connection compartment (a).
3. Push the two securing screws (b) through the appropriate bores (c) in the housing.
 - Securing screws (M6): max. \varnothing 6.5 mm (0.26")
 - Screw head: max. \varnothing 10.5 mm (0.41")
4. Secure the transmitter housing to the wall as indicated.
5. Screw the cover of the connection compartment (a) firmly onto the housing.

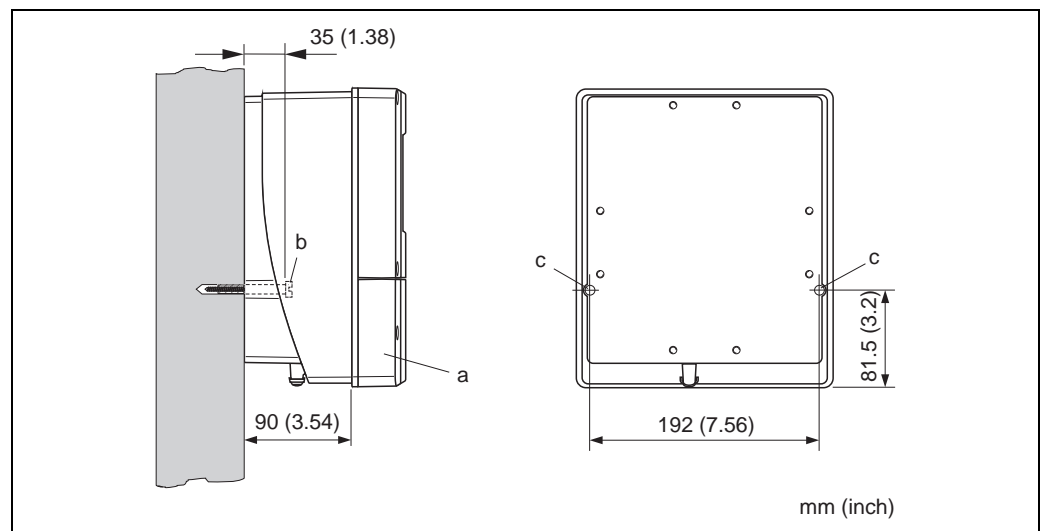

Fig. 10: Direct wall mounting

Panel mounting

1. Prepare the opening in the panel → 18.
2. Slide the housing into the panel cutout from the front.
3. Screw the retainers onto the wall-mount housing.
4. Screw the threaded rods into the retainers and tighten until the housing is solidly seated on the panel wall. Tighten the counter nuts. No further support is necessary.

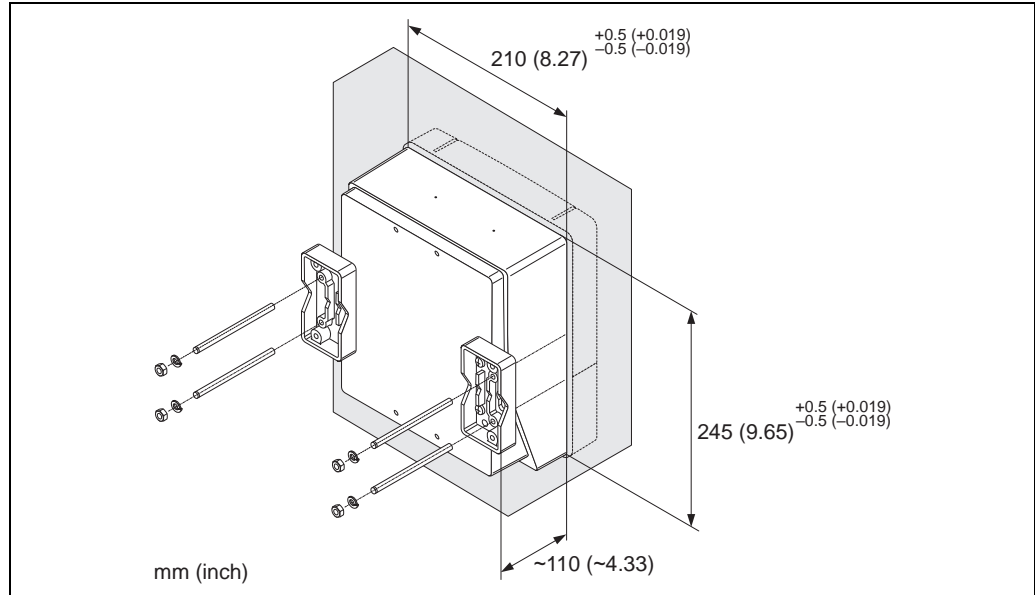

Fig. 11: Panel mounting (wall-mount housing)

Pipe mounting

The assembly should be performed by following the instructions on → 18.

**Caution!**

If a warm pipe is used for installation, make sure that the housing temperature does not exceed the max. permitted value of +60 °C (+140 °F).

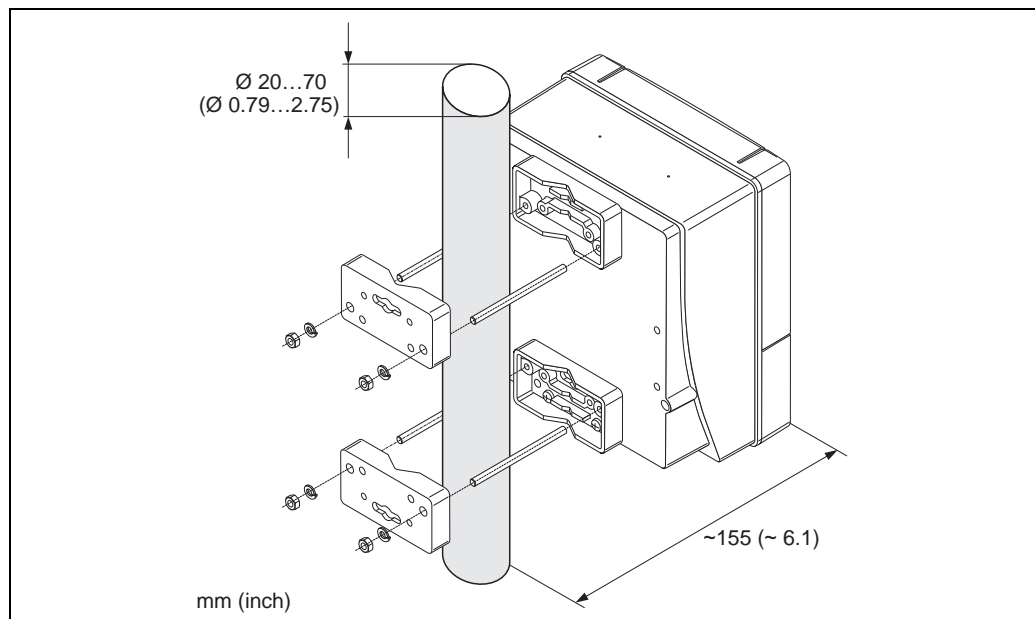

Fig. 12: Pipe mounting (wall-mount housing)

Connecting the power supply



Warning!

When connecting Ex-certified devices, please refer to the notes and diagrams in the Ex-specific supplement to these Operating Instructions. Please do not hesitate to contact your Endress+Hauser sales office if you have any questions.



Note!

The measuring device does not have an internal power switch. For this reason, assign the measuring device a switch or power-circuit breaker which can be used to disconnect the power supply line from the power grid.

Connecting the power supply



Warning!

- Risk of electric shock. Switch off the power supply before opening the device. Do not install or wire the device while it is connected to the power supply. Failure to comply with this precaution can result in irreparable damage to the electronics.
- Risk of electric shock. Connect the protective ground to the ground terminal on the housing before the power supply is applied (not required for galvanically isolated power supply).
- Compare the specifications on the nameplate with the local supply voltage and frequency. The national regulations governing the installation of electrical equipment also apply.

1. Remove the cover of the connection compartment from the transmitter housing.
2. Route the power supply cable through the cable entries.
3. Wire the power supply cable.
4. Tighten the cable gland.
5. Screw the connection compartment cover back onto the transmitter housing.

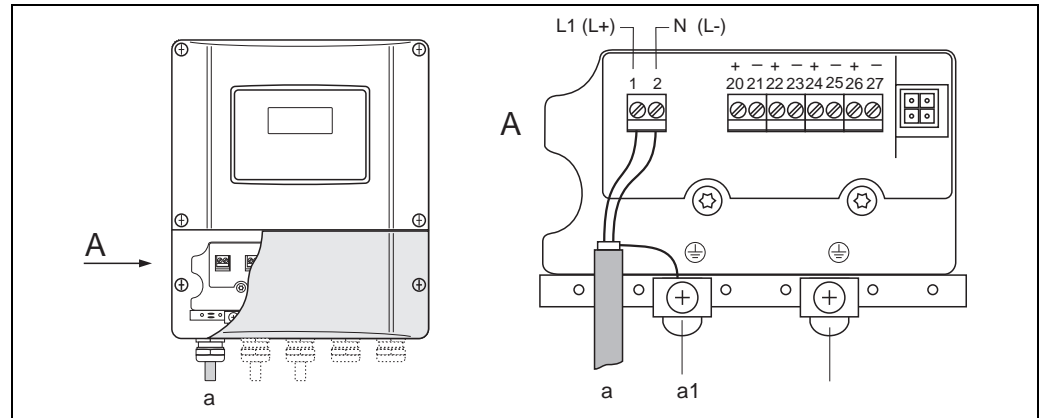

Fig. 13: Connecting the power supply; cable cross-section: max. 2.5 mm² (14 AWG)

a Cable for power supply: 85 to 260 V AC, 20 to 55 V AC, 16 to 62 V DC

Terminal **No. 1**: L1 for AC, L+ for DC

Terminal **No. 2**: N for AC, L- for DC

a1 Ground terminal for protective ground

Switching on the measuring device

1. Perform the post-connection check as specified in the checklist → 65.
2. Switch on the supply voltage for the device. The device performs internal test functions. Various messages appear on the display.
3. Normal measuring mode commences. Various measured value and/or status variables appear on the display (HOME position).



Note!

If startup fails, an appropriate error message is displayed, depending on the cause → 105.

Running the "Sensor Installation" Quick Setup menu



Note!

- If you are not familiar with the operation of the device → 66.
- The following section only describes the steps necessary for clamp-on and insertion type of mounting within the "Sensor Installation" Quick Setup.

Running the Quick Setup for clamp-on type of mounting

1. Enter or select installation-specific values or the values specified here.
2. Read off the installation distances necessary for mounting.

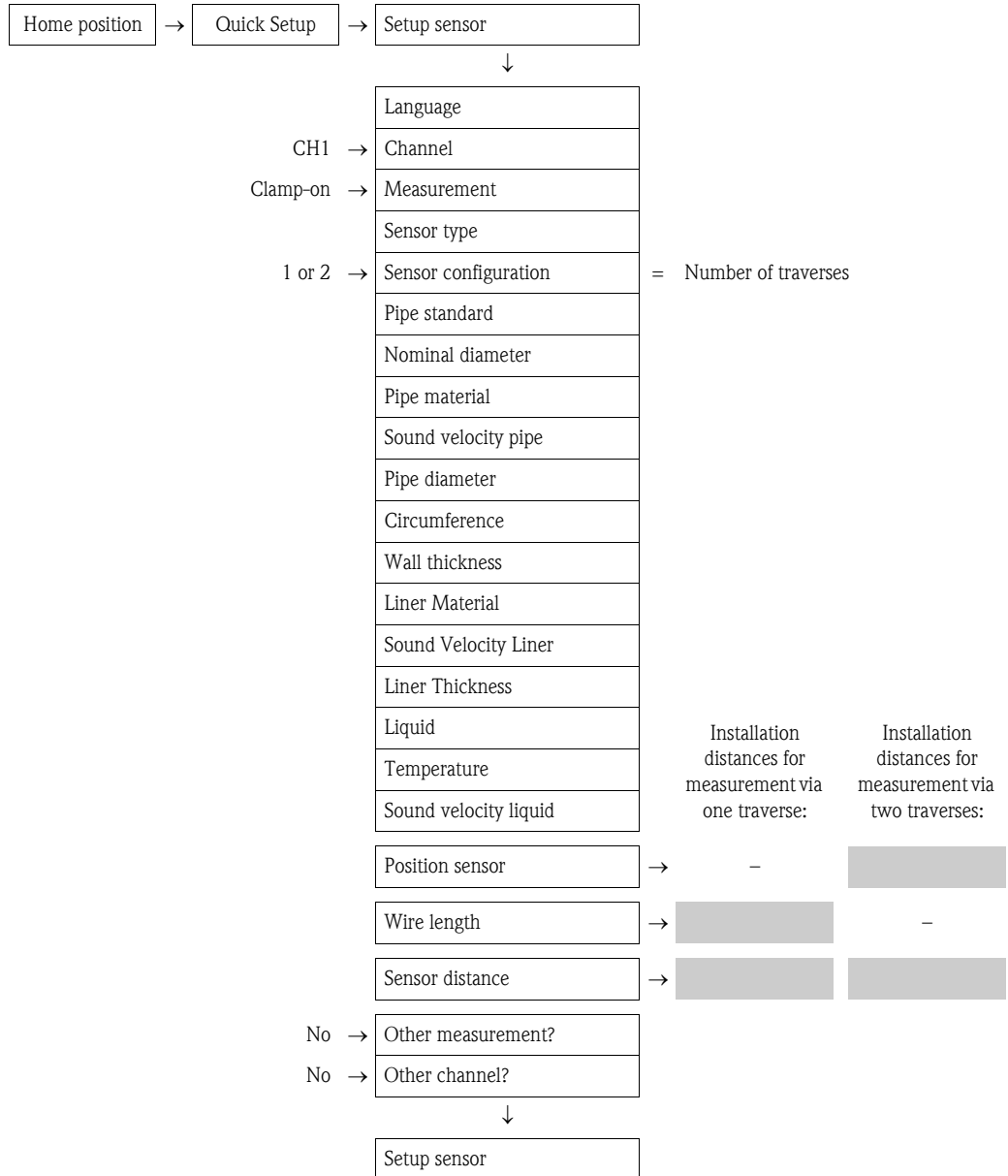

Subsequent procedure

The sensors can be installed once the installation distances have been determined:

- Prosonic Flow P or W (DN 15 to 65 / ½ to 2½) → 37
- Prosonic Flow P (DN 50 to 4000 / 2 to 160") → 37
- Prosonic Flow W → 41

Running the Quick Setup for insertion type of mounting

1. Enter or select installation-specific values or the values specified here.
2. Read off the installation distances necessary for mounting.

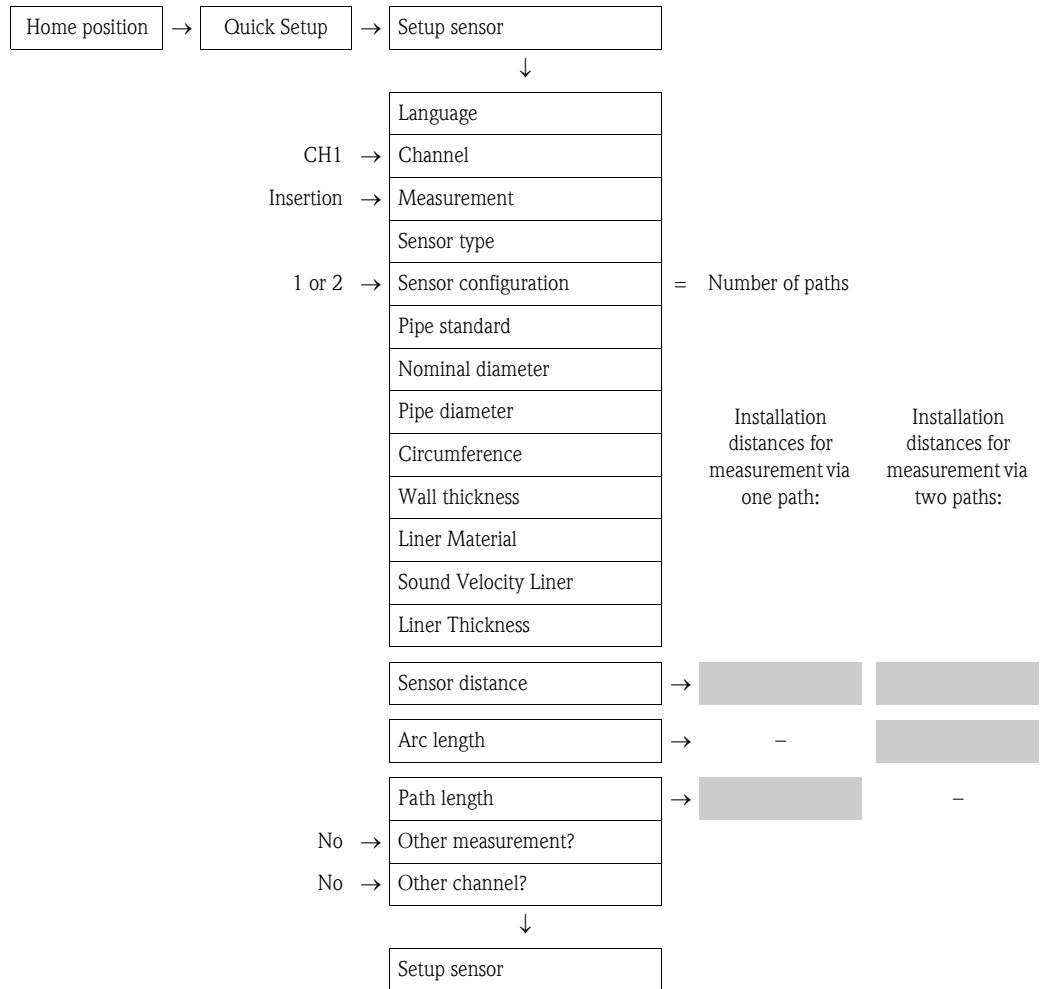

Subsequent procedure

The sensors can be installed once the installation distances have been determined:

- Prosonic Flow W → 45

3.6.2 Determining installation distances via FieldCare

FieldCare is Endress+Hauser's FDT-based plant asset management tool and allows the configuration and diagnosis of intelligent field devices. The Proline flowmeters are accessed via a service interface or via the service interface FXA193.

FieldCare and the FXA193 service interface can be ordered as accessories → [101](#).

Perform the following steps to determine the installation distances:

1. Mount the wall-mount housing
2. Connecting the power supply
3. Connecting the PC to the plant asset management tool
4. Switch on the measuring device.
5. Read off the installation distances via FieldCare.

Installing the wall-mount transmitter housing

There are various ways of installing the wall-mount housing:

- Direct wall mounting

Panel mounting (with separate mounting kit, accessories) → [101](#)

Pipe mounting (with separate mounting kit, accessories) → [101](#)



Caution!

- Make sure that the permitted operating temperature range (-20 to +60 °C / -4 to +140 °F) is not exceeded at the mounting location. Install the device in a shady location. Avoid direct sunlight.
- Always install the wall-mount housing in such a way that the cable entries are pointing down.

Direct wall mounting

1. Drill the holes → [22](#).
2. Remove the cover of the connection compartment (a).
3. Push the two securing screws (b) through the appropriate bores (c) in the housing.
 - Securing screws (M6): max. Ø 6.5 mm (0.26")
 - Screw head: max. Ø 10.5 mm (0.41")
4. Secure the transmitter housing to the wall as indicated.
5. Screw the cover of the connection compartment (a) firmly onto the housing.

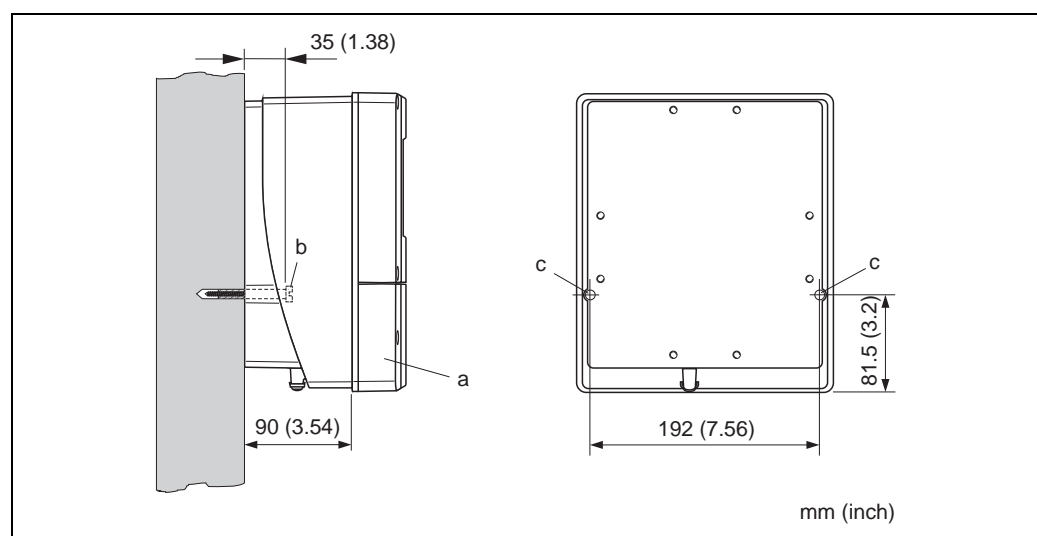

Fig. 14: Direct wall mounting

A0001130

Panel mounting

1. Prepare the opening in the panel → 23.
2. Slide the housing into the panel cutout from the front.
3. Screw the retainers onto the wall-mount housing.
4. Screw the threaded rods into the retainers and tighten until the housing is solidly seated on the panel wall. Tighten the counter nuts. No further support is necessary.

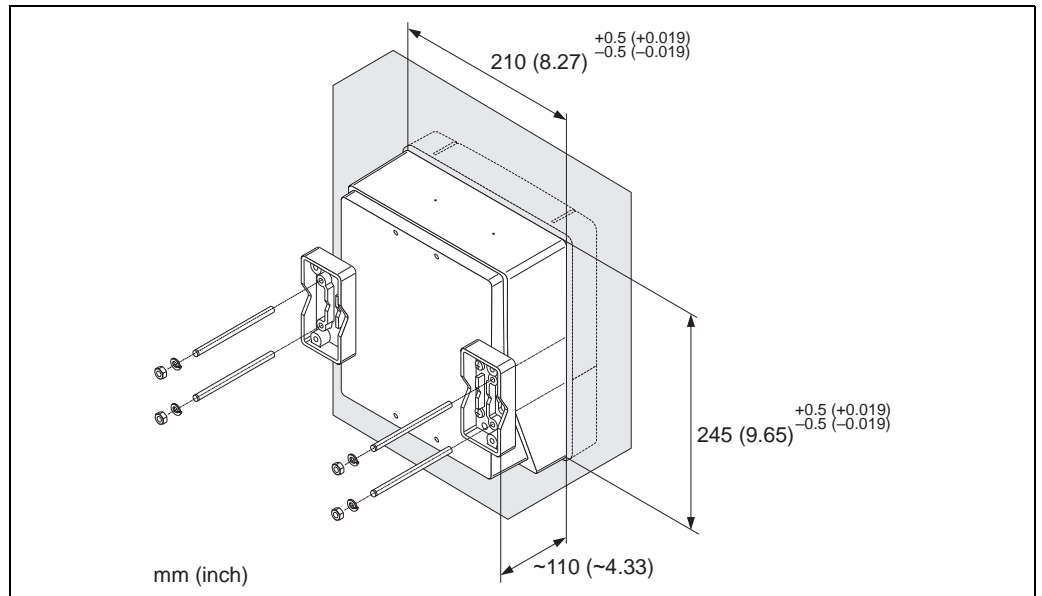

Fig. 15: Panel mounting (wall-mount housing)

Pipe mounting

The assembly should be performed by following the instructions on → 23.

**Caution!**

If a warm pipe is used for installation, make sure that the housing temperature does not exceed the max. permitted value of +60 °C (+140 °F).

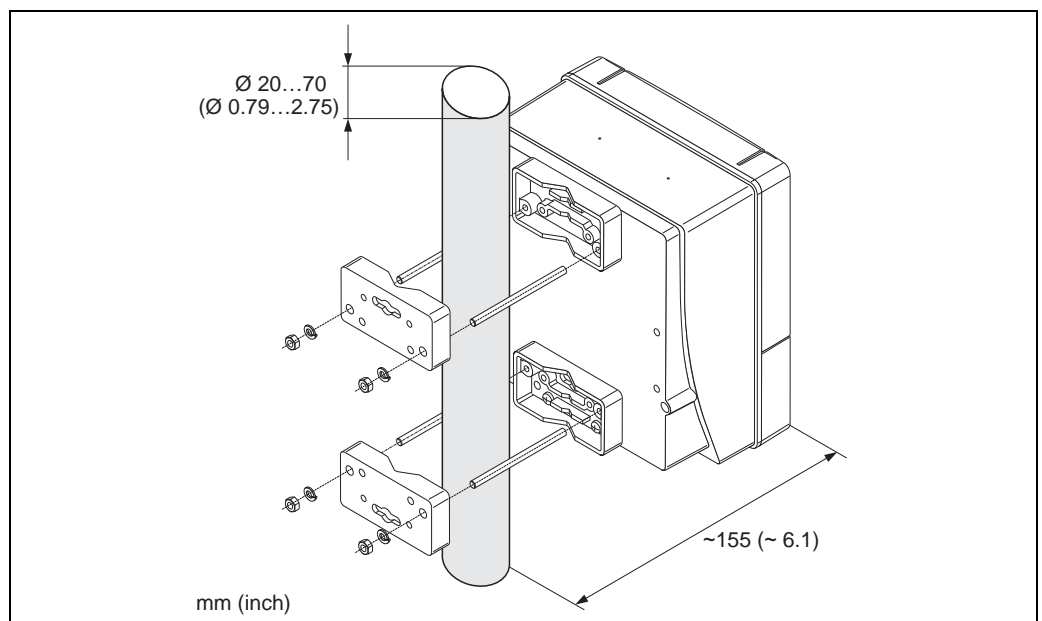

Fig. 16: Pipe mounting (wall-mount housing)

Connecting the power supply



Warning!

When connecting Ex-certified devices, please refer to the notes and diagrams in the Ex-specific supplement to these Operating Instructions. Please do not hesitate to contact your Endress+Hauser sales office if you have any questions.



Note!

The measuring device does not have an internal power switch. For this reason, assign the measuring device a switch or power-circuit breaker which can be used to disconnect the power supply line from the power grid.

Connecting the power supply



Warning!

- Risk of electric shock. Switch off the power supply before opening the device. Do not install or wire the device while it is connected to the power supply. Failure to comply with this precaution can result in irreparable damage to the electronics.
- Risk of electric shock. Connect the protective ground to the ground terminal on the housing before the power supply is applied (not required for galvanically isolated power supply).
- Compare the specifications on the nameplate with the local supply voltage and frequency. The national regulations governing the installation of electrical equipment also apply.

1. Remove the cover of the connection compartment from the transmitter housing.
2. Route the power supply cable through the cable entries.
3. Wire the power supply cable.
4. Tighten the cable gland.

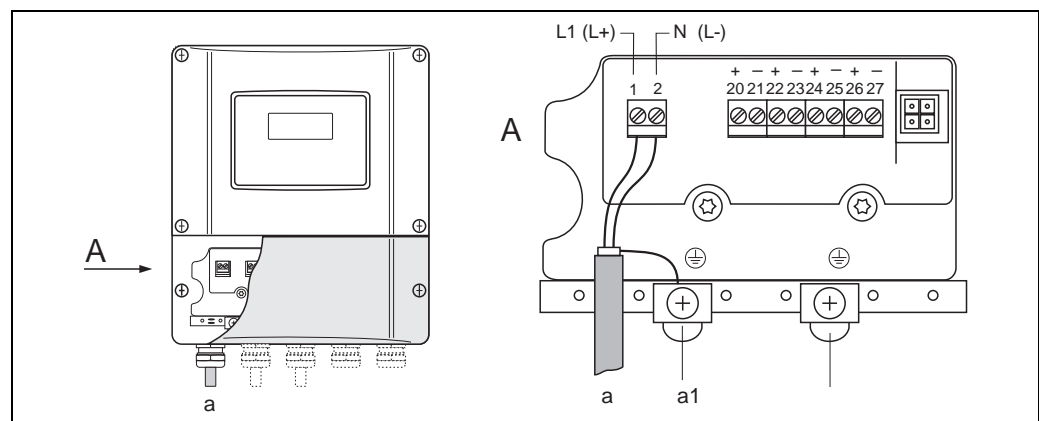

Fig. 17: Connecting the power supply; cable cross-section: max. 2.5 mm² (14 AWG)

- a Cable for power supply: 85 to 260 V AC, 20 to 55 V AC, 16 to 62 V DC
 Terminal **No. 1**: L1 for AC, L+ for DC
 Terminal **No. 2**: N for AC, L- for DC
 a1 Ground terminal for protective ground

Connecting the PC to the plant asset management tool

A personal computer is connected to the FieldCare plant asset management tool via the service interface FXA 193. The service interface FXA 193 is connected to the service connector of the transmitter.

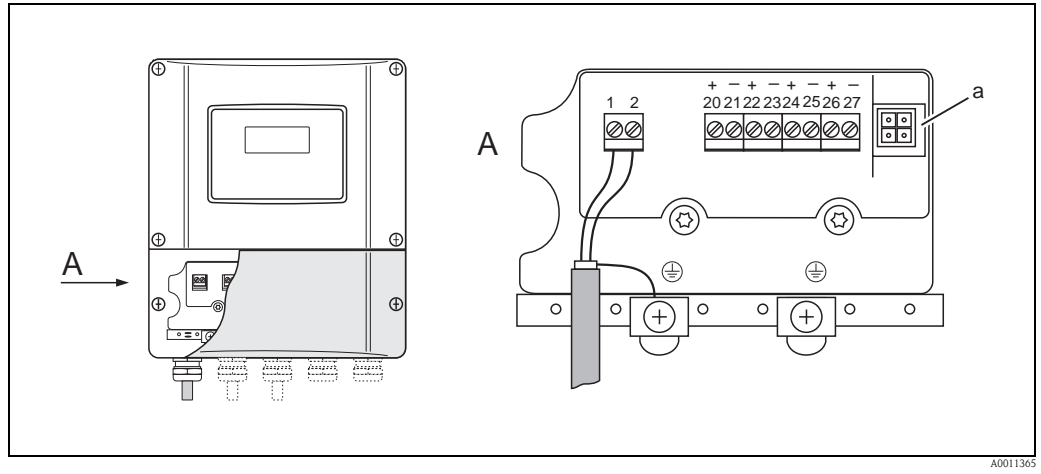

Fig. 18: Connecting a PC with the FieldCare operating software

a Service adapter for connecting service interface FXA193

Switching on the measuring device

1. Perform the post-connection check as specified in the checklist → 65.
2. Switch on the supply voltage for the device. The device performs internal test functions. Various messages appear on the display.
3. Normal measuring mode commences. Various measured value and/or status variables appear on the display (HOME position).



Note!

If startup fails, an appropriate error message is displayed, depending on the cause → 105.

Reading off the installation distances via FieldCare



Note!

The following section only illustrates the functions necessary for clamp-on and insertion type of mounting.

Reading off installation distances via FieldCare for clamp-on type of mounting

1. Enter or select installation-specific values or the values specified here.
2. Read off the installation distances necessary for mounting.

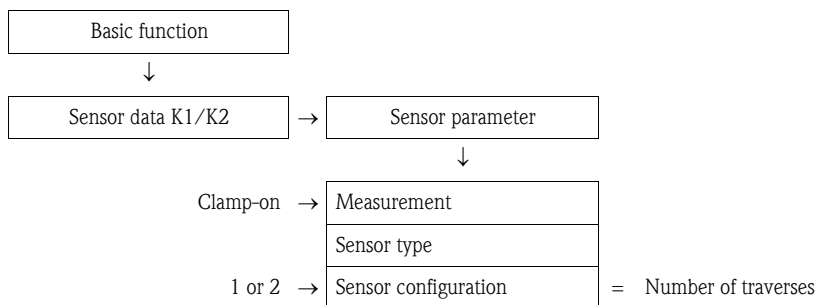

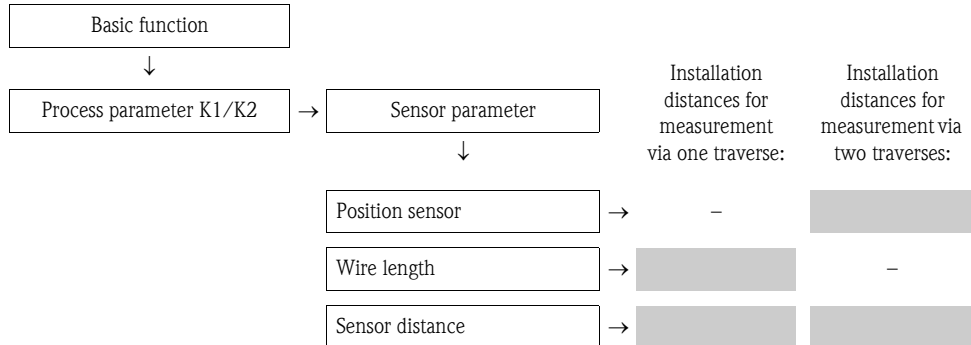
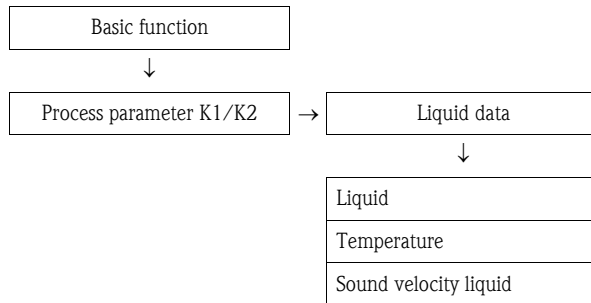
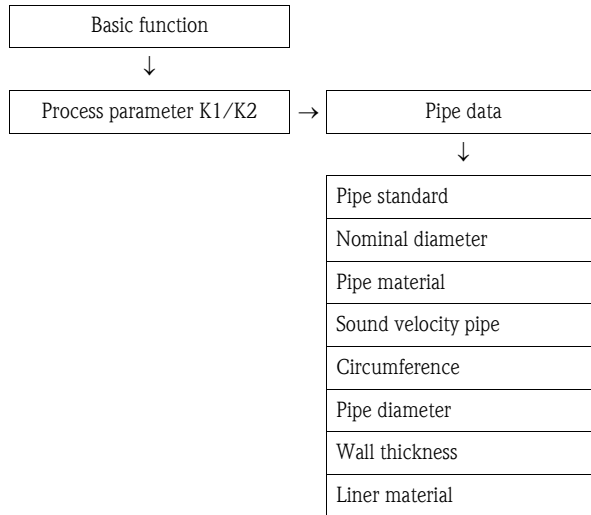

Subsequent procedure

The sensors can be installed once the installation distances have been determined:

- Prosonic Flow P or W (DN 15 to 65 / ½ to 2½") → 35
- Prosonic Flow P (DN 50 to 4000 / 2 to 160") → 37
- Prosonic Flow W (Clamp-on) → 41

Reading off installation distances via FieldCare for insertion type of mounting

1. Enter or select installation-specific values or the values specified here.
2. Read off the installation distances necessary for mounting.

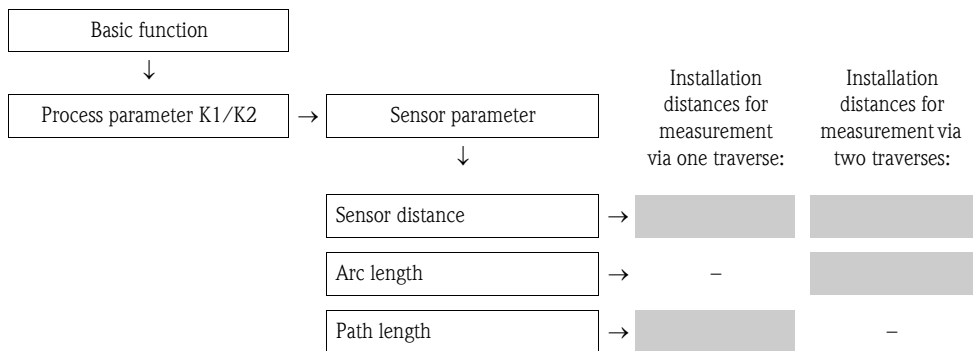
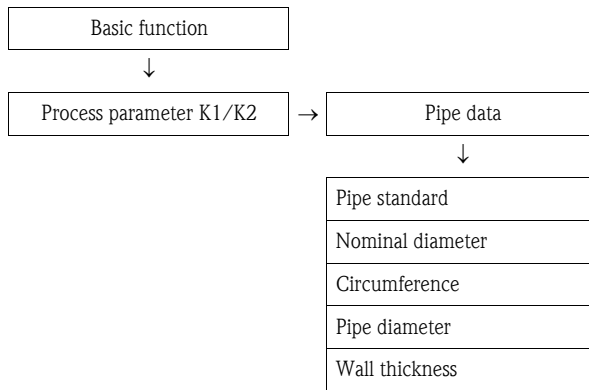
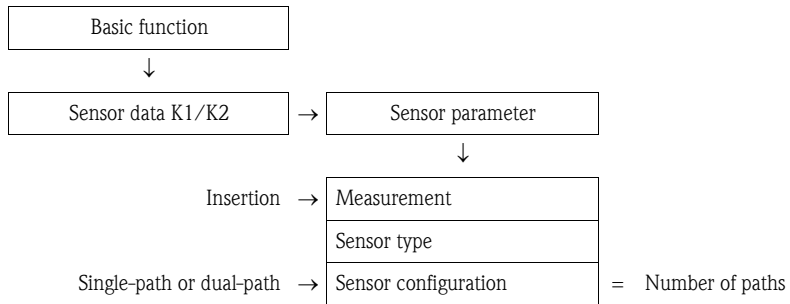

Subsequent procedure

The sensors can be installed once the installation distances have been determined:

- Prosonic Flow W → 45.

3.6.3 Determining installation distances via Applicator

Applicator is a software application for selecting and planning flowmeters. The installation distances required for installation can be determined without having to commission the transmitter beforehand.

Applicator is available:

- On a CD-ROM for installation on a local PC →  104.
- Via the Internet for direct online entry → www.endress.com → select country.
On the Internet site, select → Instruments → Flow → Tooling → Applicator. In the "Applicator Sizing Flow" field, select the "Start Applicator Sizing Flow online" link.



Determining installation distances for clamp-on, measuring via one traverse

Determine the installation distances required via Applicator:

- Select the fluid.
- Select the device (e.g. 93P Clamp-on).
- Enter or select measuring point-specific values.
- Select the number of traverses: 1
- Read off the necessary installation distances:
 - Wire length: _____
 - Sensor distance: _____

Subsequent procedure

The sensors can be installed once the installation distances have been determined:

- Prosonic Flow P (DN 50 to 4000 / 2 to 160") →  37
- Prosonic Flow W →  41.



Determining installation distances for clamp-on, measuring via two traverses

Determine the installation distances required via Applicator:

- Select the fluid.
- Select the device (e.g. 93P Clamp-on).
- Enter or select measuring point-specific values.
- Select the number of traverses: 2
- Read off the necessary installation distances:
 - Sensor position: _____
 - Sensor distance: _____

Subsequent procedure

The sensors can be installed once the installation distances have been determined:

- Prosonic Flow P or W (DN 15 to 65 / ½ to 2½") →  39
- Prosonic Flow P (DN 50 to 4000 / 2 to 160") →  39
- Prosonic Flow W →  43.

Determining installation distances for insertion version, single-path measurement

Determine the installation distances required via Applicator:

- Select the fluid.
- Select the device (e.g. 93W Insert 1Ch).
- Enter or select measuring point-specific values.
- Read off the necessary installation distance:
 - Sensor distance: _____

Subsequent procedure

The sensors can be installed once the installation distances have been determined:

- Prosonic Flow W →  46.

Determining installation distances for insertion version, dual-path measurement

Determine the installation distances required via Applicator:

- Select the fluid.
- Select the device (e.g. 93W Insert 2Ch).
- Enter or select measuring point-specific values.
- Read off the necessary installation distances:
 - Sensor distance: _____
 - Arc length: _____

Subsequent procedure

The sensors can be installed once the installation distances have been determined:

- Prosonic Flow W →  41.

3.7 Mechanical preparation

The way in which the sensors are secured differs on account of the pipe nominal diameter and the sensor type. Depending on the type of sensor, users also have the option of securing the sensors with strapping bands or screws such that they can be later removed, or permanently fixing the sensors in place with welded bolts or welded retainers.

Overview of possible ways to secure the various sensors:

Prosonic Flow	For the measuring range	Pipe nominal diameter	Secured by
93W/93P	DN 15 to 65 (½ to 2½")	DN ≤ 32 (1¼")	Sensor holder with U-shaped screws → 30
		DN > 32 (1¼")	Sensor holder with strapping bands → 31
93P	DN 50 to 4000 (2 to 160")	DN ≤ 200 (8")	Strapping bands (medium nominal diameters) → 32
			Welded bolts → 34
		DN > 200 (8")	Strapping bands (large nominal diameters) → 33
			Welded bolts → 34
93W	DN 50 to 4000 (2 to 160")	DN ≤ 200 (8")	Strapping bands (medium nominal diameters) → 32
			Welded bolts → 34
		DN > 200 (8")	Strapping bands (large nominal diameters) → 33
			Welded bolts → 31
			Insertion version → 45

3.7.1 Mounting the sensor holder with U-shaped screws

For mounting on a pipe with a nominal diameter of DN ≤ 32 (1¼")

For sensors: Prosonic Flow 93W or P (DN 15 to 65 / ½ to 2½")

Procedure

1. Disconnect the sensor from the sensor holder.
2. Position the sensor holder on the pipe.
3. Put the U-shaped screws through the sensor holder and slightly lubricate the thread.
4. Screw nuts onto the U-shaped screws.
5. Set the holder to the exact position and tighten the nuts evenly.



Warning!

Risk of damaging plastic or glass pipes if the nuts of the U-shaped screws are tightened too much! The use of a metal half-shell is recommended (on the opposite side of the sensor) when working with plastic or glass pipes.



Note!

The visible pipe surface "A" must be smooth to ensure good acoustic contact.

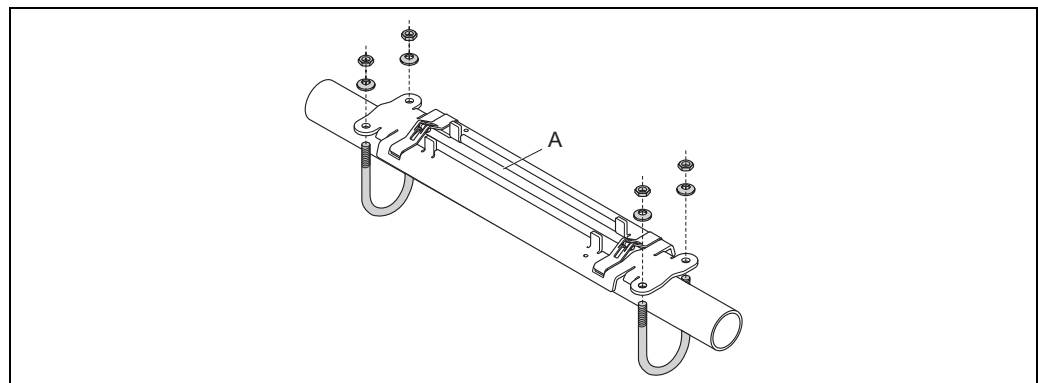

A0011XXXX

Fig. 19: Mounting the Prosonic Flow P or W sensor holder (DN 15 to 65 / ½ to 2½") with U-shaped screws

3.7.2 Mounting the sensor holder with strapping bands

For mounting on a pipe with a nominal diameter of $DN > 32$ (1¼")

For sensors:

- Prosonic Flow 93W or P (DN 15 to 65 / ½ to 2½")

Procedure

1. Disconnect the sensor from the sensor holder.
2. Position the sensor holder on the pipe.
3. Wrap the strapping bands around the sensor holder and pipe without twisting them.
4. Guide the strapping bands through the strapping band locks (strapping screw is pushed up).
5. Tighten the strapping bands as tight as possible by hand.
6. Set the sensor holder to the correct position.
7. Push down the strapping screw and tighten the strapping bands so that they cannot slip.
8. Where necessary, shorten the strapping bands and trim the cut edges.



Warning!

Risk of injury. To avoid sharp edges, trim the cut edges after shortening the strapping bands.

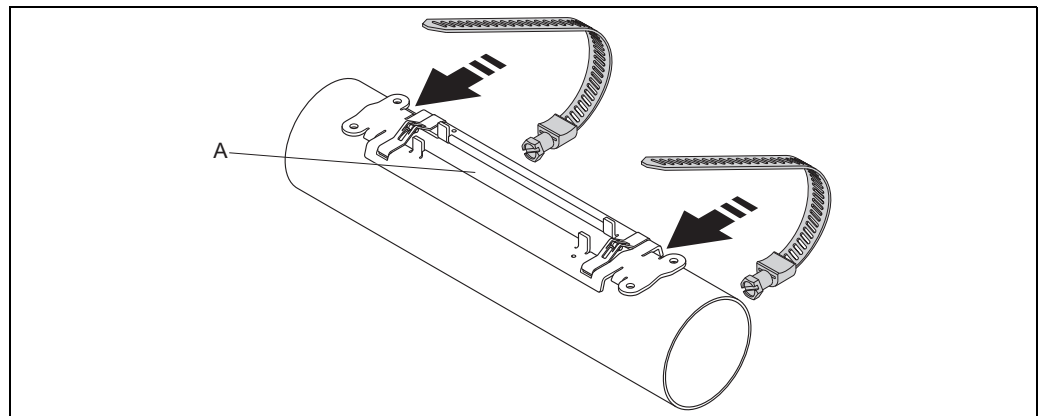

Fig. 20: Positioning the sensor holder and mounting the strapping bands



Note!

The visible pipe surface "A" must be smooth to ensure good acoustic contact.

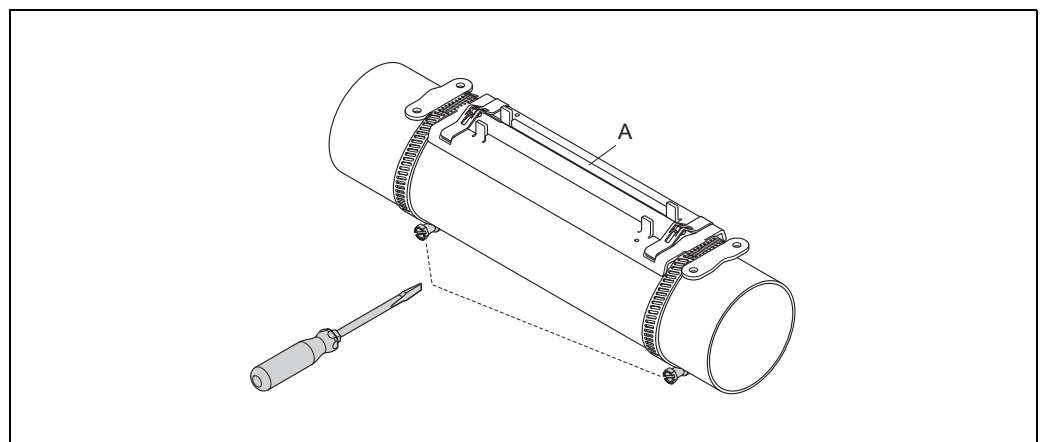

Fig. 21: Tightening the strapping screws of the strapping bands

3.7.3 Premounting the strapping bands (medium nominal diameters)

When mounting on a pipe with a nominal diameter of $DN \leq 200$ (8")

For sensors:

- Prosonic Flow 93W or P (DN 50 to 4000 / 2 to 160")

Procedure

First strapping band

1. Fit the mounting bolt over the strapping band.
2. Wrap the strapping band around the pipe without twisting it.
3. Guide the end of the strapping band through the strapping band lock (strapping screw is pushed up).
4. Tighten the strapping band as tight as possible by hand.
5. Set the strapping band to the desired position.
6. Push down the strapping screw and tighten the strapping band so that it cannot slip.

Second strapping band

7. Proceed as for the first strapping band (steps 1 to 7). Only slightly tighten the second strapping band for final mounting. It must be possible to move the strapping band for final alignment.

Both strapping bands

8. Where necessary, shorten the strapping bands and trim the cut edges.



Warning!

Risk of injury. To avoid sharp edges, trim the cut edges after shortening the strapping bands.

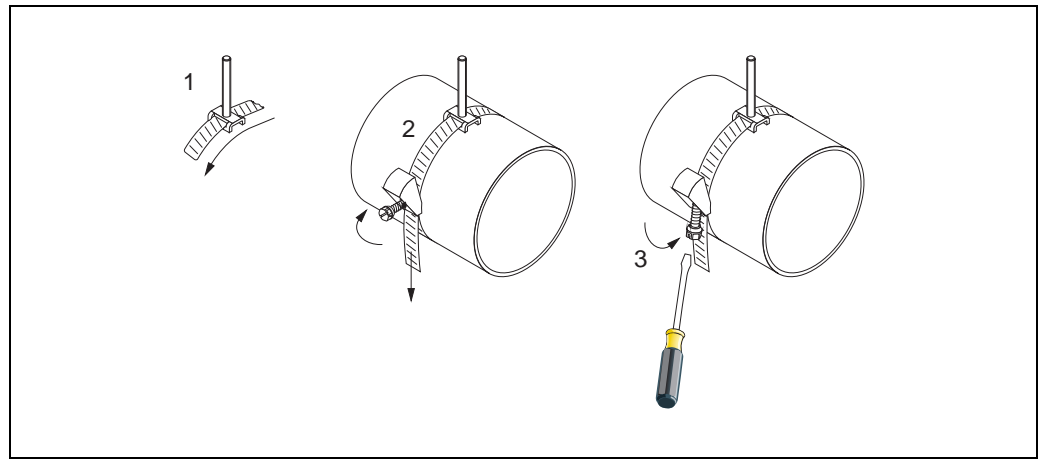

Fig. 22: Premounting strapping bands for pipe diameters $DN \leq 200$ (8")

- 1 Mounting bolt
- 2 Strapping band
- 3 Strapping screw

3.7.4 Premounting the strapping bands (large nominal diameters)

When mounting on a pipe with a nominal diameter in the range of
 DN > 600 (24")

For sensors:

- Prosonic Flow 93W or P (DN 50 to 4000 / 2 to 160")

Procedure

1. Measure the pipe circumference.
2. Shorten the strapping bands to one length (pipe circumference + 32 cm (12.6 in)) and trim the cut edges.



Warning!

Risk of injury. To avoid sharp edges, trim the cut edges after shortening the strapping bands.

First strapping band

3. Fit the mounting bolt over the strapping band.
4. Wrap the strapping band around the pipe without twisting it.
5. Guide the end of the strapping band through the strapping band lock (strapping screw is pushed up).
6. Tighten the strapping band as tight as possible by hand.
7. Set the strapping band to the desired position.
8. Push down the strapping screw and tighten the strapping band so that it cannot slip.

Second strapping band

9. Proceed as for the first strapping band (steps 3 to 8). Only slightly tighten the second strapping band for final mounting. It must be possible to move the strapping band for final alignment.

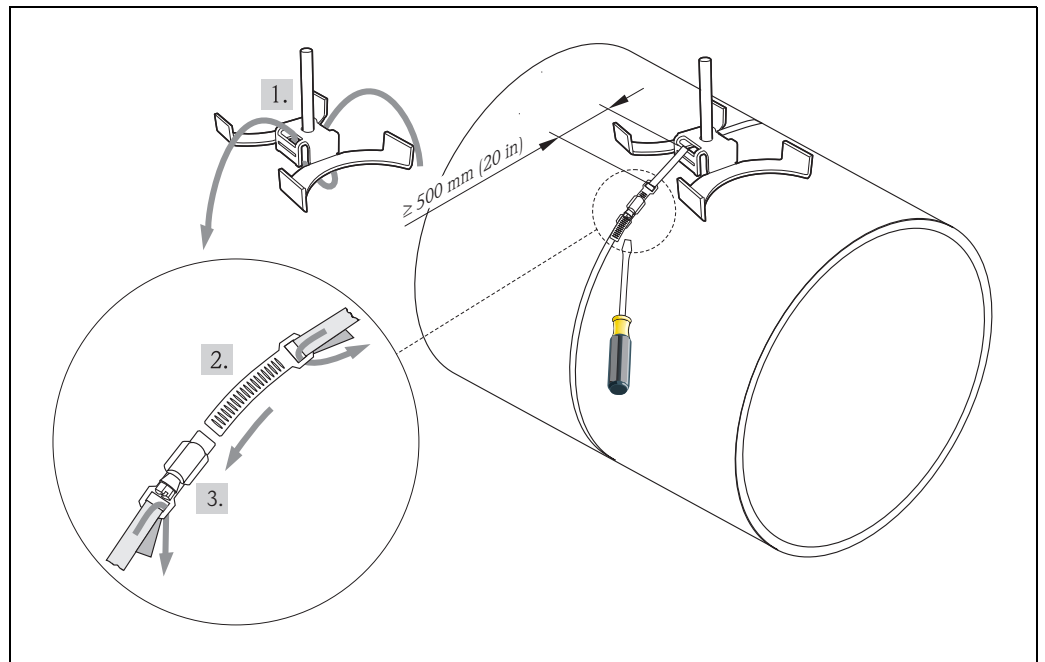

Fig. 23: Premounting strapping bands for pipe diameters DN > 600 (24")

1 Mounting bolt with guide*

2 Strapping band*

3 Strapping screw

* Distance between mounting bolt and strapping band lock min. 500 mm (20 in)

3.7.5 Mounting the welded bolts

When mounting on a pipe with a nominal diameter of DN 50 to 4000 (2 to 160")

For sensors:

- Prosonic Flow 93P (DN 50 to 4000 / 2 to 160")
- Prosonic Flow 93W

Procedure

The welded bolts must be fixed at the same installation distances as the mounting bolts with strapping bands. The following sections explain how to align the mounting bolts depending on the type of mounting and the measurement method:

- Prosonic Flow P (DN 50 to 4000 / 2 to 160"), Clamp-on
 - Installation for measurement via one traverse → 37
 - Installation for measurement via two traverses → 39.
- Prosonic Flow W, Clamp-on
 - Installation for measurement via one traverse → 41
 - Installation for measurement via two traverses → 43.

The sensor holder is secured with a retaining nut with a metric ISO M6 thread as standard.

If you want to use another thread to secure the sensor holder, you must use a sensor holder with a removable retaining nut (order number: 93WAx - xBxxxxxxxxxx).

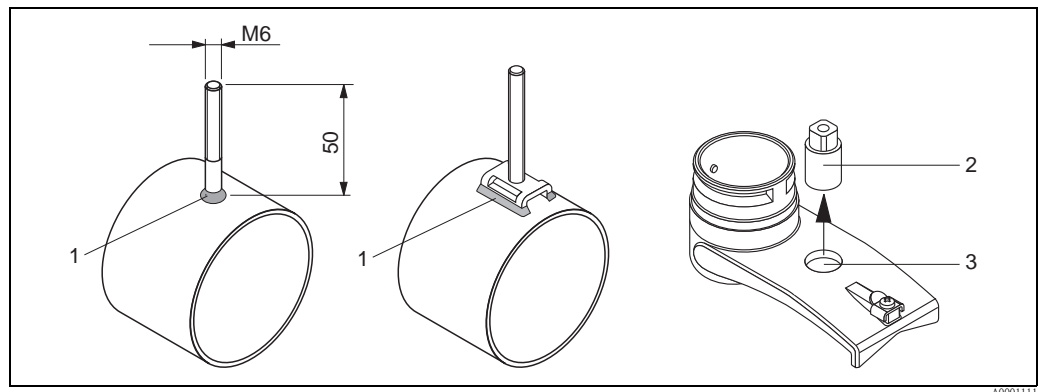

Fig. 24: Use of welded bolts

- 1 Welding seam
- 2 Retaining nut
- 3 Hole diameter max. 8.7 mm (0.34")

3.8 Installing Prosonic Flow W and P (DN 15 to 65 / ½ to 2½")

3.8.1 Mounting the sensor

Prerequisites

- The installation distance (sensor distance) is known → 16.
- The sensor holder is already mounted → 30.

Material

The following material is needed for mounting:

- Sensor incl. adapter cable
- Connecting cable for connecting to the transmitter
- Coupling fluid for an acoustic connection between the sensor and pipe

Procedure

1. Set the distance between the sensors as per the value determined for the sensor distance. Press the movable sensor down slightly to move it.

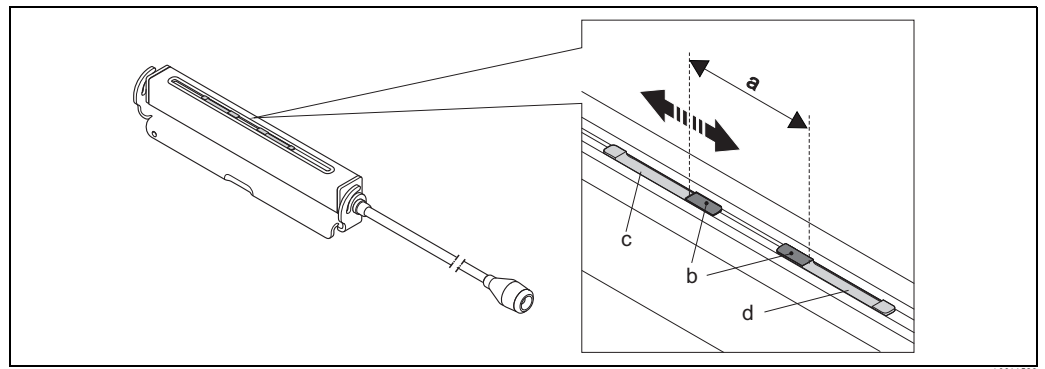

Fig. 25: Setting the distance between the sensors as per the value for the sensor distance

- a Sensor distance (backside of sensor contact surface)
- b Contact surfaces of the sensor
- c Movable sensor
- d Fixed sensor

2. Coat the contact surfaces of the sensors with an even layer of coupling fluid (approx. 0.5 to 1 mm / 0.02 to 0.04") thick.
3. Fit the sensor housing on the sensor holder.



Note!

- Avoid to use a thick layer of the coupling fluid (less is more).
- Clean and reapply new coupling fluid when sensor is removed from the pipe.
- The sensor (DN 15 to 65 / ½" to 2½") requires a smooth pipe surface.

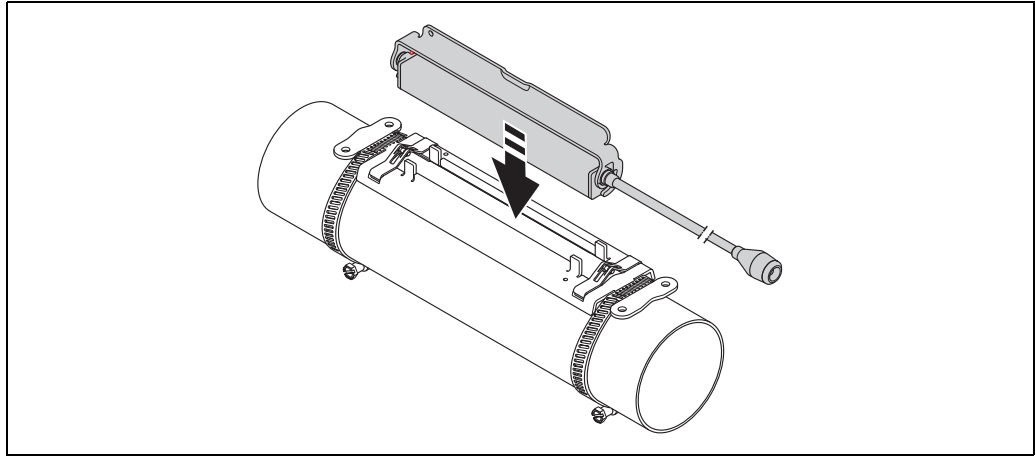



Fig. 26: Fitting the sensor housing

4. Fix the sensor housing with the bracket.

 Note!

- If necessary, the holder and sensor housing can be secured with a screw/nut or a lead-seal (not part of the scope of supply).
- The bracket can only be released using an auxiliary tool.

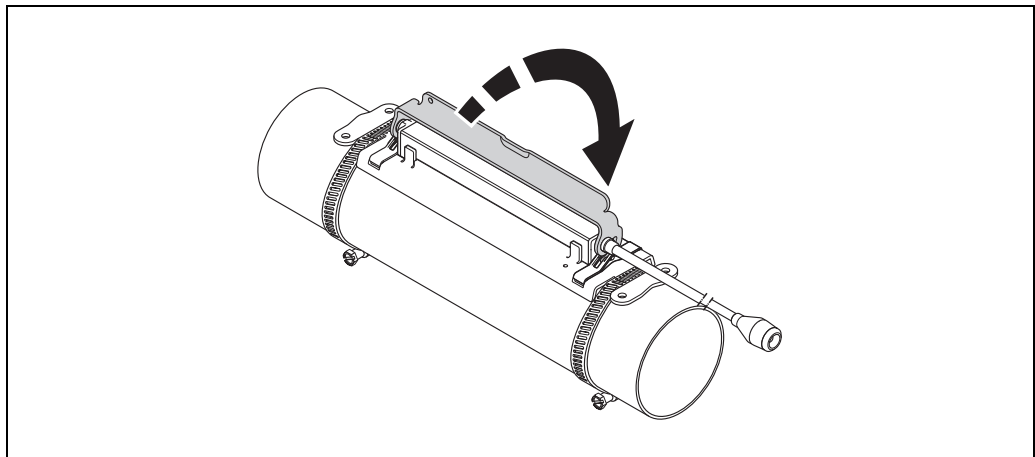



Fig. 27: Fixing the sensor housing

5. Connect the connecting cable to the adapter cable.

This completes the mounting process. The sensors can now be connected to the transmitter via the connecting cables →  61.

3.9 Installing Prosonic Flow P DN 50 to 4000 (2 to 160") (Clamp-on)

3.9.1 Installation for measurement via one traverse

Prerequisites

- The installation distances (sensor distance and wire length) are known → 16.
- The strapping bands are already mounted → 30.

Material

The following material is needed for mounting:

- Two strapping bands incl. mounting bolts and centering plates where necessary (already mounted → 30)
- Two measuring wires, each with a cable lug and a fixer to position the strapping bands
- Two sensor holders
- Coupling fluid for an acoustic connection between the sensor and pipe
- Two sensors incl. connecting cables.

Procedure

1. Prepare the two measuring wires:
 - Arrange the cable lugs and fixer such that the distance they are apart corresponds to the wire length (SL).
 - Screw the fixer onto the measuring wire.

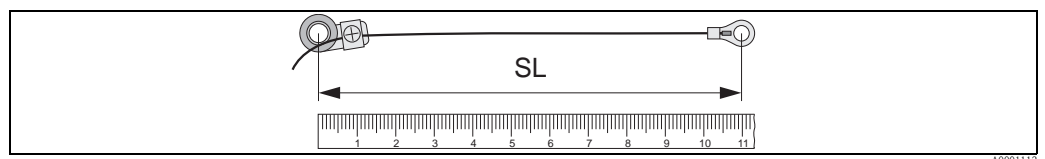

Fig. 28: Fixer (a) and cable lugs (b) at a distance that corresponds to the wire length (SL)

2. With the first measuring wire:
 - Fit the fixer over the mounting bolt of the strapping band that is already securely mounted.
 - Run the measuring wire **clockwise** around the pipe.
 - Fit the cable lug over the mounting bolt of the strapping band that can still be moved.
3. With the second measuring wire:
 - Fit the cable lug over the mounting bolt of the strapping band that is already securely mounted.
 - Run the measuring wire **counterclockwise** around the pipe.
 - Fit the fixer over the mounting bolt of the strapping band that can still be moved.
4. Take the still movable strapping band, incl. the mounting bolt, and move it until both measuring wires are evenly tensioned and tighten the strapping band so that it cannot slip.

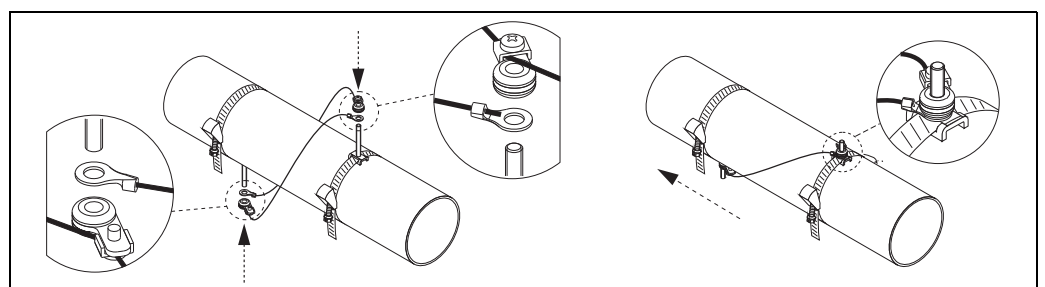

Fig. 29: Positioning the strapping bands (steps 2 to 4)

5. Loosen the screws of the fixers on the measuring wires and remove the measuring wires from the mounting bolt.
6. Fit the sensor holders over the individual mounting bolts and tighten securely with the retaining nut.

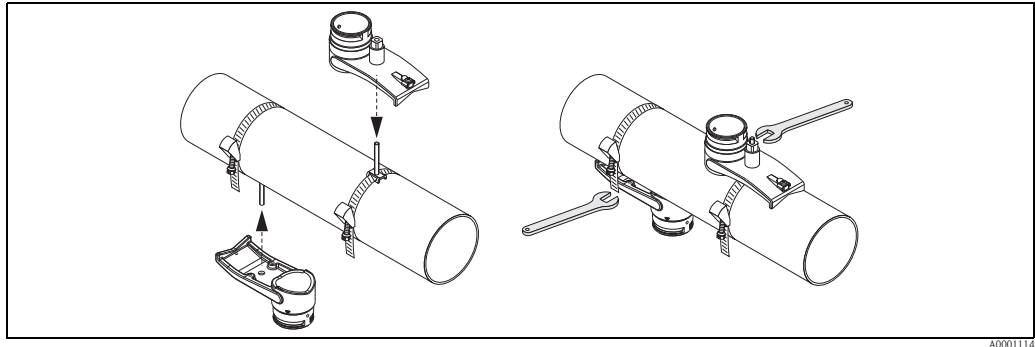

Fig. 30: Mounting the sensor holders

7. Coat the contact surfaces of the sensors with an even layer of coupling fluid approx. 1 mm (0.04") thick, going from the groove through the center to the opposite edge.



Note!

- Avoid to use a thick layer of the coupling fluid (less is more).
- Clean and reapply new coupling fluid when the sensor is removed from the pipe.
- On rough pipe surface e.g. GRP pipes ensure that the gaps crevices within the surface roughness are filled. Apply sufficient coupling fluid.

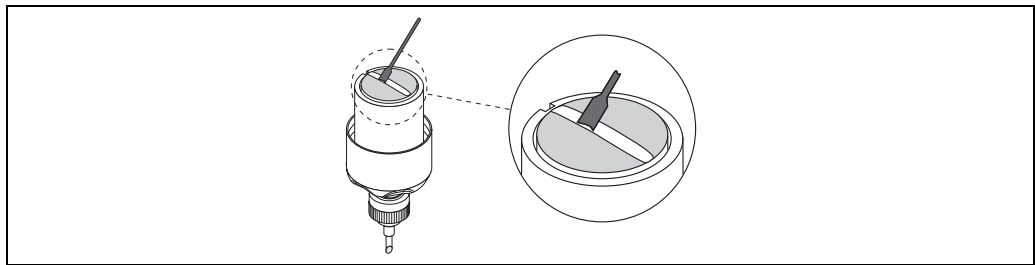

Fig. 31: Coating the contact surfaces of the sensor with coupling fluid

8. Insert the sensor into the sensor holder.
9. Fit the sensor cover on the sensor holder and turn until:
 - The sensor cover engages with a click
 - The arrows (▲ / ▼ "close") are pointing towards one another.
10. Screw the connecting cable into the individual sensor.

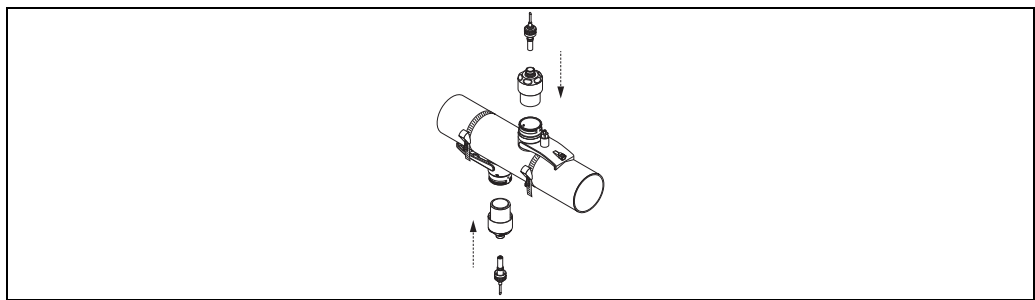

Fig. 32: Mounting the sensor and connecting the connecting cable

This completes the mounting process. The sensors can now be connected to the transmitter via the connecting cables → 61.

3.9.2 Installation for measurement via two traverses

Prerequisites

- The installation distance (position sensor) is known → 16.
- The strapping bands are already mounted → 30.

Material

The following material is needed for mounting:

- Two strapping bands incl. mounting bolts and centering plates where necessary (already mounted → 30)
- A mounting rail to position the strapping bands
- Two mounting rail retainers
- Two sensor holders
- Coupling fluid for an acoustic connection between the sensor and pipe
- Two sensors incl. connecting cables.

Mounting rail and POSITION SENSOR installation distance

The mounting rail has two rows with bores. The bores in one of the rows are indicated by letters and the bores in the other row are indicated by numerical values. The value determined for the POSITION SENSOR installation distance is made up of a letter and a numerical value.

The bores that are identified by the specific letter and numerical value are used to position the strapping bands.

Procedure

1. Position the strapping bands with the aid of the mounting rail.
 - Slide the mounting rail with the bore identified by the letter from POSITION SENSOR over the mounting bolt of the strapping band that is permanently fixed in place.
 - Position the movable strapping band and slide the mounting rail with the bore identified by the numerical value from POSITION SENSOR over the mounting bolt.

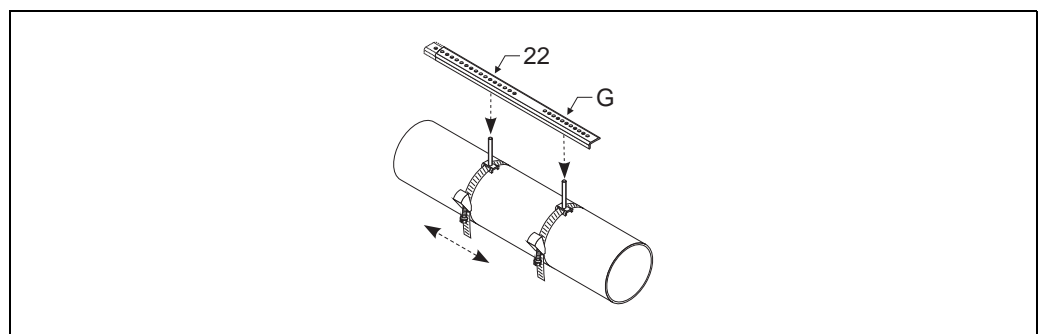

Fig. 33: Determining the distance in accordance with the mounting rail (e.g. POSITION SENSOR G22)

2. Tighten the strapping band so that it cannot slip.
3. Remove the mounting rail from the mounting bolt.
4. Fit the sensor holders over the individual mounting bolts and tighten securely with the retaining nut.
5. Screw the retainers of the mounting rail onto the sensor holder in question.
6. Screw the mounting rail onto the sensor holders.

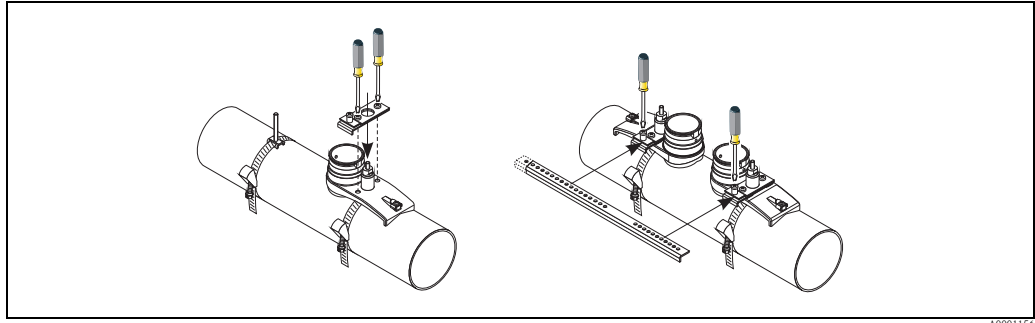

Fig. 34: Mounting the sensor holders and mounting rail

7. Coat the contact surfaces of the sensors with an even layer of coupling fluid approx. 1 mm (0.04") thick, going from the groove through the center to the opposite edge.



Note!

- Avoid to use a thick layer of the coupling fluid (less is more).
- Clean and reapply new coupling fluid when sensor is removed from the pipe.
- On rough pipe surfaces e.g. GRP pipes ensure that the gaps crevices within the surface roughness are filled. Apply sufficient coupling fluid.

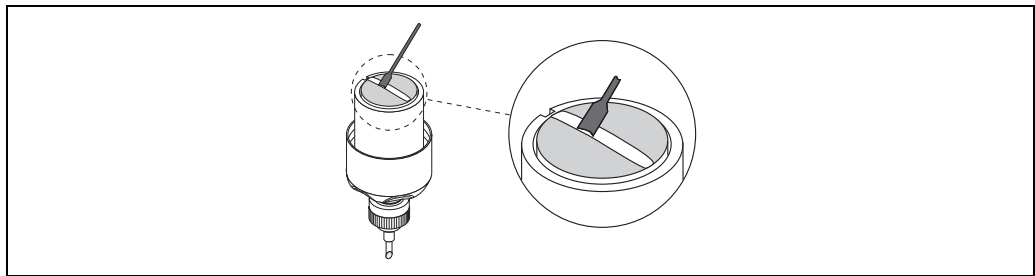

Fig. 35: Coating the contact surfaces of the sensor with coupling fluid

8. Insert the sensor into the sensor holder.
9. Fit the sensor cover on the sensor holder and turn until:
 - The sensor cover engages with a click
 - The arrows (▲ / ▼ "close") are pointing towards one another.
10. Screw the connecting cable into the individual sensor.

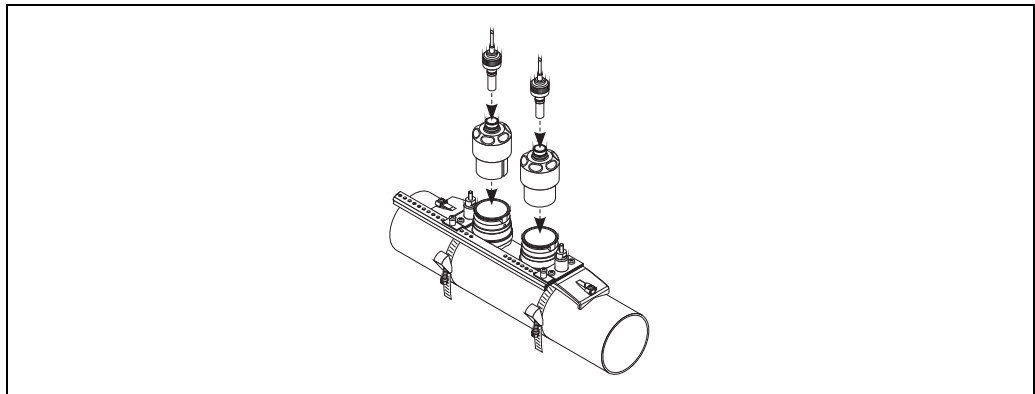

Fig. 36: Mounting the sensor and connecting the connecting cable

This completes the mounting process. The sensors can now be connected to the transmitter via the connecting cables → [61](#).

3.10 Installing Prosonic Flow W (Clamp-on)

3.10.1 Installation for measurement via one traverse

Prerequisites

- The installation distances (sensor distance and wire length) are known → 16.
- The strapping bands are already mounted → 30.

Material

The following material is needed for mounting:

- Two strapping bands incl. mounting bolts and centering plates where necessary (already mounted → 30)
- Two measuring wires, each with a cable lug and a fixer to position the strapping bands
- Two sensor holders
- Coupling fluid for an acoustic connection between the sensor and pipe
- Two sensors incl. connecting cables.

Procedure

1. Prepare the two measuring wires:
 - Arrange the cable lugs and fixer such that the distance they are apart corresponds to the wire length (SL).
 - Screw the fixer onto the measuring wire.

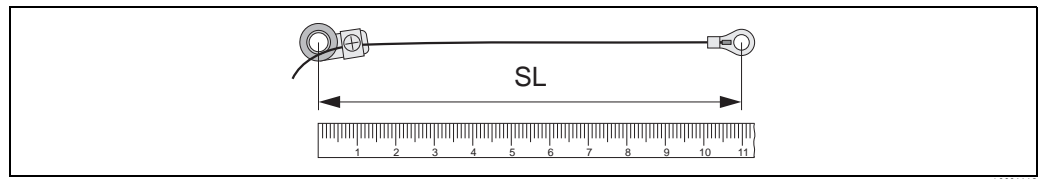

Fig. 37: Fixer (a) and cable lugs (b) at a distance that corresponds to the wire length (SL)

2. With the first measuring wire:
 - Fit the fixer over the mounting bolt of the strapping band that is already securely mounted.
 - Run the measuring wire **clockwise** around the pipe.
 - Fit the cable lug over the mounting bolt of the strapping band that can still be moved.
3. With the second measuring wire:
 - Fit the cable lug over the mounting bolt of the strapping band that is already securely mounted.
 - Run the measuring wire **counterclockwise** around the pipe.
 - Fit the fixer over the mounting bolt of the strapping band that can still be moved.
4. Take the still movable strapping band, incl. the mounting bolt, and move it until both measuring wires are evenly tensioned and tighten the strapping band so that it cannot slip.

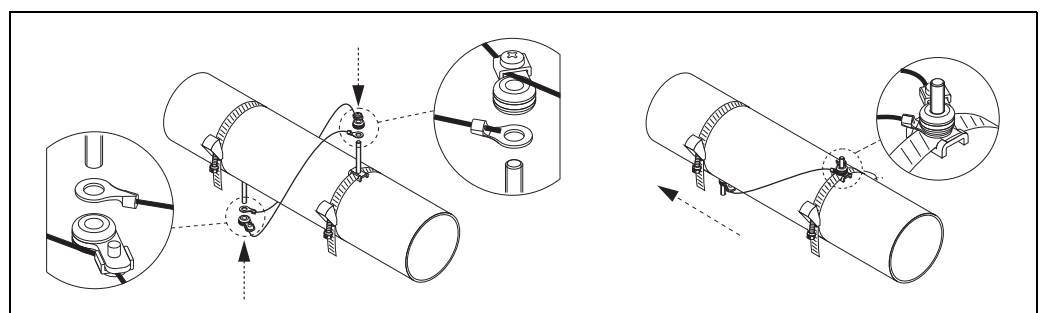

Fig. 38: Positioning the strapping bands (steps 2 to 4)

5. Loosen the screws of the fixers on the measuring wires and remove the measuring wires from the mounting bolt.
6. Fit the sensor holders over the individual mounting bolts and tighten securely with the retaining nut.

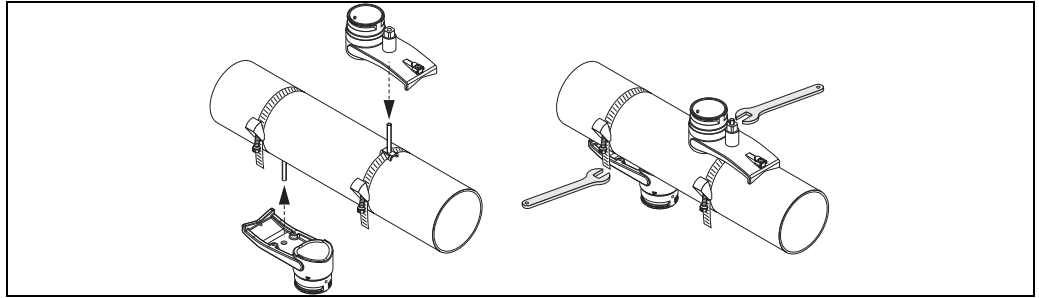

Fig. 39: Mounting the sensor holders

7. Coat the contact surfaces of the sensors with an even layer of coupling fluid approx. 1 mm (0.04") thick, going from the groove through the center to the opposite edge.



Note!

- Avoid to use a thick layer of the coupling fluid (less is more).
- Clean and reapply new coupling fluid when sensor is removed from the pipe.
- On rough pipe surfaces e.g. GRP pipes ensure that the gaps crevices within the surface roughness are filled. Apply sufficient coupling fluid.

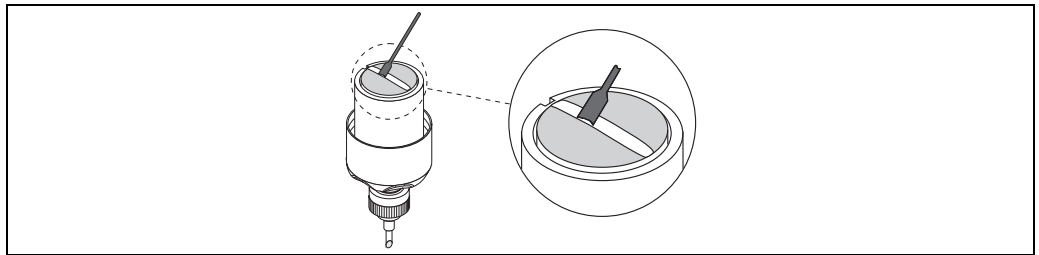

Fig. 40: Coating the contact surfaces of the sensor with coupling fluid

8. Insert the sensor into the sensor holder.
9. Fit the sensor cover on the sensor holder and turn until:
 - The sensor cover engages with a click
 - The arrows (▲ / ▼ "close") are pointing towards one another.
10. Screw the connecting cable into the individual sensor.

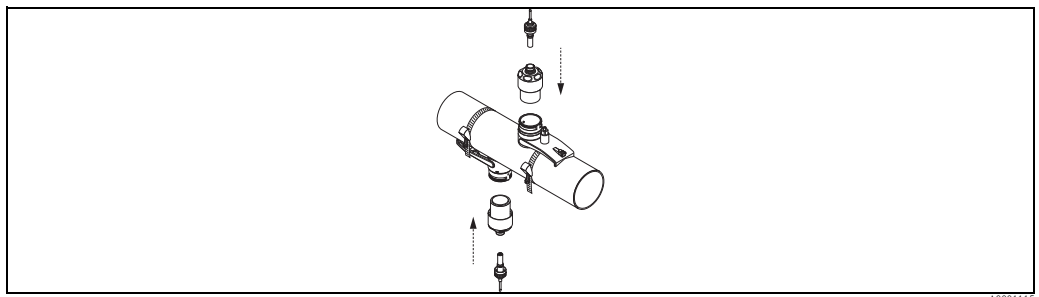

Fig. 41: Mounting the sensor and connecting the connecting cable

This completes the mounting process. The sensors can now be connected to the transmitter via the connecting cables → 61.

3.10.2 Installation for measurement via two traverses

Prerequisites

- The installation distance (position sensor) is known → 16.
- The strapping bands are already mounted → 30.

Material

The following material is needed for mounting:

- Two strapping bands incl. mounting bolts and centering plates where necessary (already mounted → 30)
- A mounting rail to position the strapping bands
- Two mounting rail retainers
- Two sensor holders
- Coupling fluid for an acoustic connection between the sensor and pipe
- Two sensors incl. connecting cables.

Mounting rail and POSITION SENSOR installation distance

The mounting rail has two rows with bores. The bores in one of the rows are indicated by letters and the bores in the other row are indicated by numerical values. The value determined for the POSITION SENSOR installation distance is made up of a letter and a numerical value.

The bores that are identified by the specific letter and numerical value are used to position the strapping bands.

Procedure

1. Position the strapping bands with the aid of the mounting rail.
 - Slide the mounting rail with the bore identified by the letter from POSITION SENSOR over the mounting bolt of the strapping band that is permanently fixed in place.
 - Position the movable strapping band and slide the mounting rail with the bore identified by the numerical value from POSITION SENSOR over the mounting bolt.

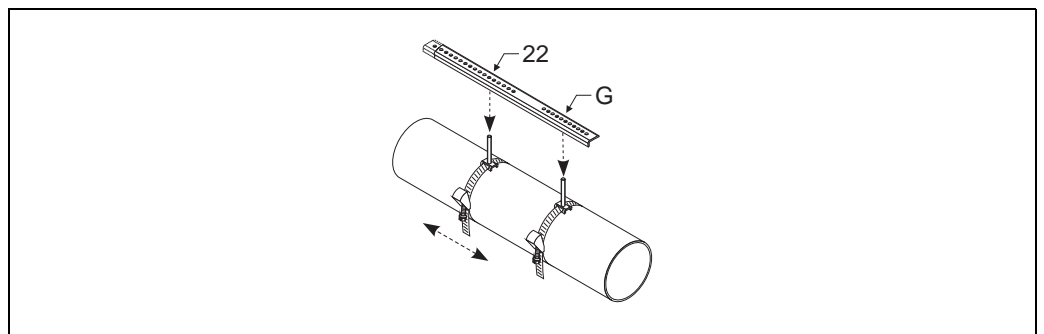

Fig. 42: Determining the distance in accordance with the mounting rail (e.g. POSITION SENSOR G22)

2. Tighten the strapping band so that it cannot slip.
3. Remove the mounting rail from the mounting bolt.
4. Fit the sensor holders over the individual mounting bolts and tighten securely with the retaining nut.

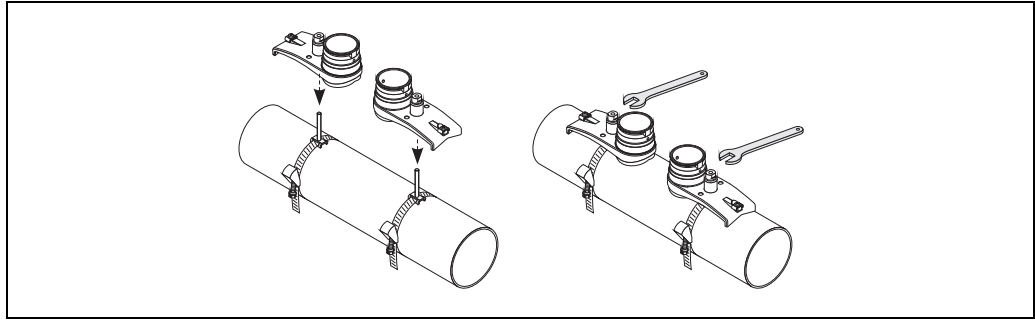

Fig. 43: Mounting the sensor

5. Coat the contact surfaces of the sensors with an even layer of coupling fluid approx. 1 mm (0.04") thick, going from the groove through the center to the opposite edge.



Note!

- Avoid to use a thick layer of the coupling fluid (less is more).
- Clean and reapply new coupling fluid when sensor is removed from the pipe.
- On rough pipe surfaces e.g. GRP pipes ensure that the gaps crevices within the surface roughness are filled. Apply sufficient coupling fluid.

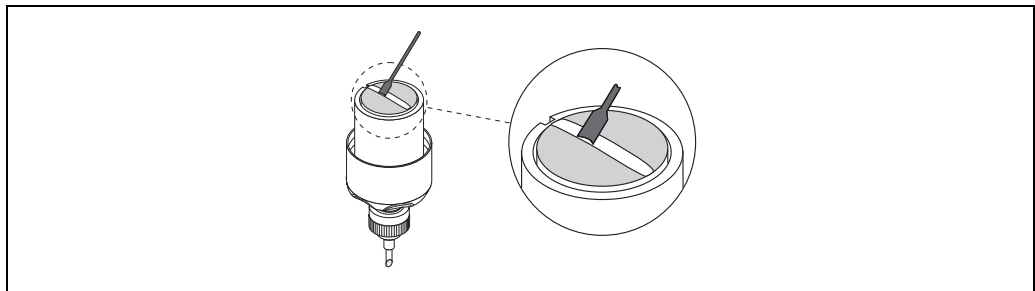

Fig. 44: Coating the contact surfaces of the sensor with coupling fluid

6. Insert the sensor into the sensor holder.
7. Fit the sensor cover on the sensor holder and turn until:
 - The sensor cover engages with a click
 - The arrows (▲ / ▼ "close") are pointing towards one another.
8. Screw the connecting cable into the individual sensor.

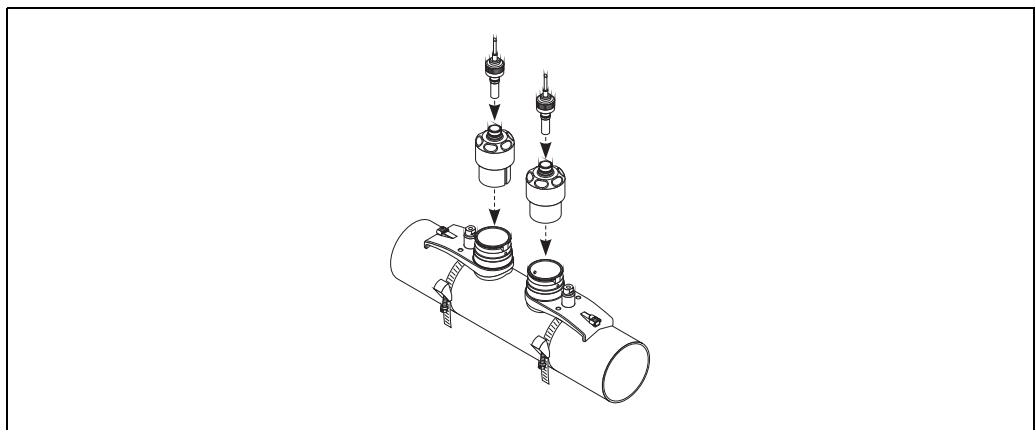
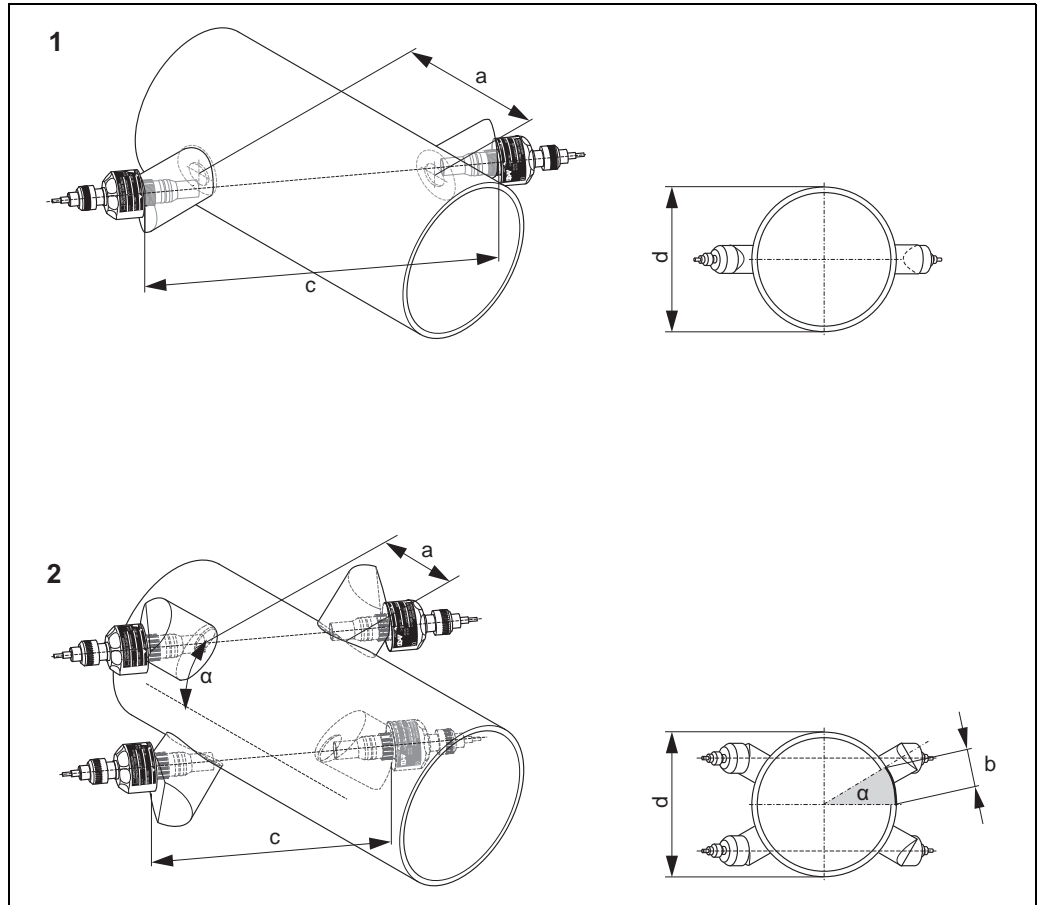

Fig. 45: Connecting the connecting cable

This completes the mounting process. The sensors can now be connected to the transmitter via the connecting cables → 61.

3.11 Installing Prosonic Flow W (Insertion version)

The graphic below provides you with an overview of the terms used when installing a Prosonic Flow W (Insertion version).



A0013926

Fig. 46: Explanation of terms

- 1 Single-path version
- 2 Dual-path version
- a Sensor distance
- b Arc length
- c Path length
- d Pipe outer diameter (is determined by the application)

3.11.1 Installation for measurement as single-path insertion version

1. Determine the installation area (e) on the pipe section:
 - Mounting location → 11
 - Inlet/outlet run → 12
 - Space required by the measuring point: approx. 1x pipe diameter.
2. Mark the middle line on the pipe at the mounting location and mark the position of the first drillhole (drillhole diameter: 65 mm / 2.56").

 Note!

Make the middle line longer than the drillhole!

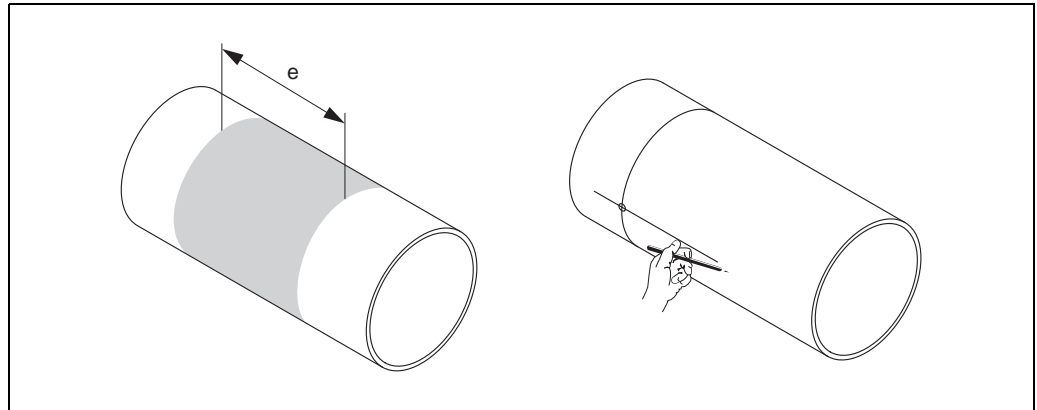



Fig. 47: Installing the measuring sensors, steps 1 and 2

3. Cut the first hole, e.g. with a plasma cutter. Measure the wall thickness of the pipe if it is not known.
4. Determine the sensor distance.

 Note!

Determine the sensor distance as follows:

- Via the Quick Setup "Sensor Installation" for measuring devices with local operation. Run the Quick Setup as described on → 84. The sensor distance is displayed in the SENSOR DISTANCE function. The transmitter must be installed and connected to the power supply before you can run the "Sensor Installation" Quick Setup.
- As explained on → 85 for transmitters without local operation.

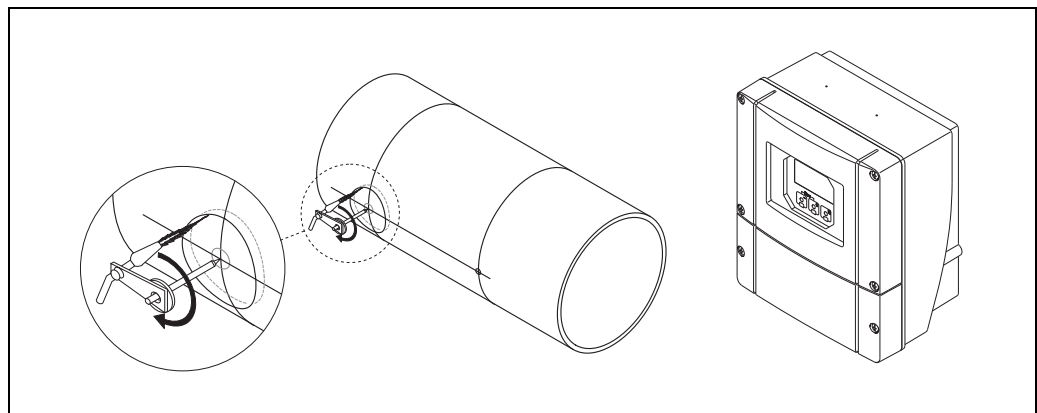

Fig. 48: Installing the measuring sensors, steps 3 and 4

5. Draw the sensor distance (a) starting from the middle line of the first drillhole.

6. Project the middle line to the back of the pipe and draw it on.

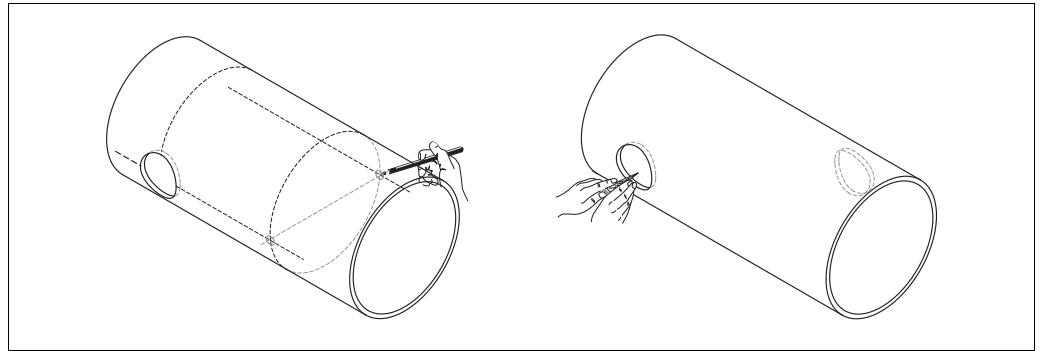

Fig. 49: Installing the measuring sensors, steps 5 and 6

7. Mark the drillhole on the middle line on the back of the pipe.
8. Cut out the second drillhole and prepare the holes for welding the sensor holders, (deburr, clean, etc.).

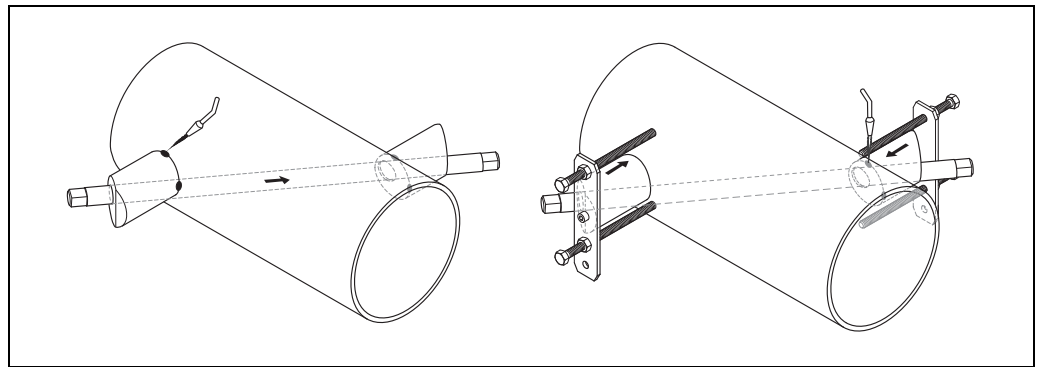

Fig. 50: Installing the measuring sensors, steps 7 and 8

9. Insert the sensor holders into the two drillholes. To adjust the weld-in depth, you can fix both sensor holders with the special tool for insertion depth regulation (optional) and then align using the tie rod. The sensor holder must be flush with the inner side of the pipe.
10. Spot-weld both sensor holders.

 Note!

To align the tie rod, you have to screw two guide bushings into the sensor holders.

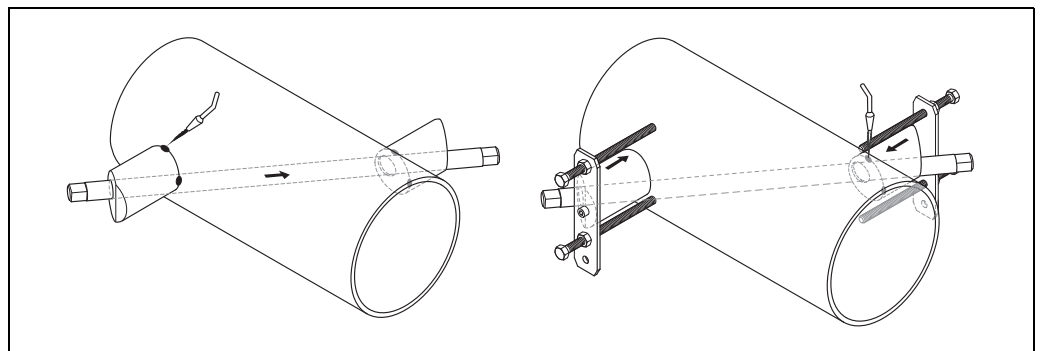





Fig. 51: Installing the measuring sensors, steps 9 and 10

11. Weld in both sensor holders.
12. Check the distance between the drillholes once again and determine the path length.

 Note!

Determine the path length as follows:

- Via the Quick Setup "Sensor Installation" for measuring devices with local operation.
Run the Quick Setup as described on →  84. The path length is displayed in the PATH LENGTH function. The transmitter must be installed and connected to the power supply before you can run the "Sensor Installation" Quick Setup.
- As explained on →  85 for transmitters without local operation.

13. Screw the sensors into the sensor holders by hand. If you use a tool, the maximum torque permissible is 30 Nm.
14. Insert the sensor cable connectors into the opening provided and manually tighten the connectors to the stop.

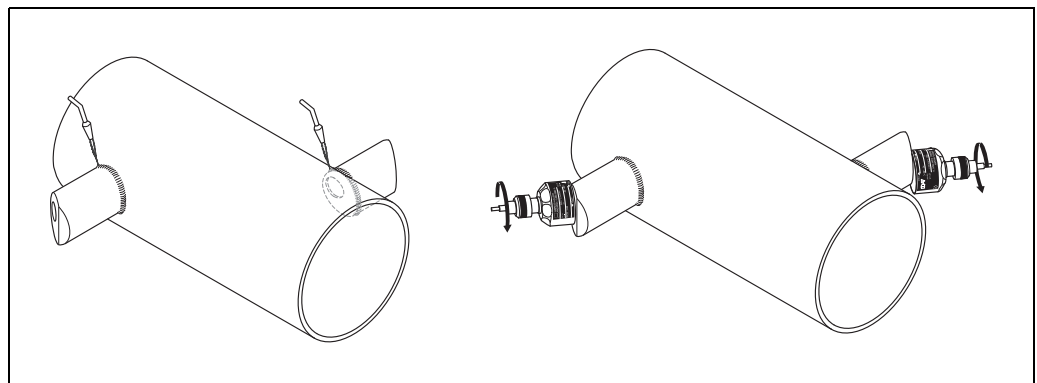

Fig. 52: Installing the measuring sensors, steps 11 to 14

A0001129

3.11.2 Installation for measurement as dual-path insertion version

1. Determine the installation area (e) on the pipe section:
 - Mounting location → [11](#)
 - Inlet/outlet run → [12](#)
 - Space required by the measuring point: approx. $1 \times$ pipe diameter.
2. Mark the middle line on the pipe at the mounting location.

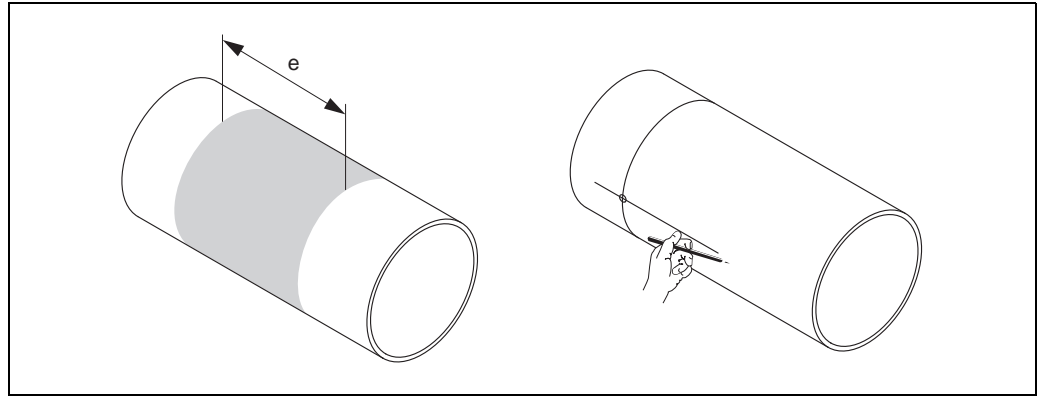

Fig. 53: Installing the dual-path measuring sensors, steps 1 and 2

3. At the mounting location of the sensor holder, mark the length of the arc (b) to one side of the middle line. Usually, the arc length is taken as approx. $1/12$ of the pipe circumference. Indicate the first drillhole (drillhole diameter approx. 81 to 82 mm / 3.19 to 3.23").



Note!

Make the lines longer than the drillhole!

4. Cut the first hole, e.g. with a plasma cutter. Measure the wall thickness of the pipe if it is not known.

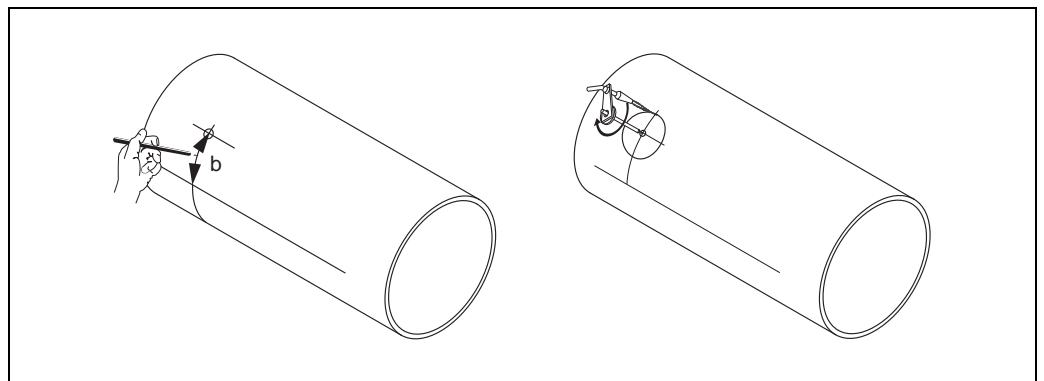

Fig. 54: Installing the dual-path measuring sensors, steps 3 and 4

5. Determine the space between the distancing holes (sensor distance) and the arc length between the sensors of the measuring groups.



Note!

Determine the sensor distance as follows:

- Via the Quick Setup "Sensor Installation" for measuring devices with local operation. Run the Quick Setup as described on → [84](#). The sensor distance is displayed in the SENSOR DISTANCE function (6886) and the arc length in the ARC LENGTH function (6887). The transmitter must be installed and connected to the power supply before you can run the "Sensor Installation" Quick Setup.
- As explained on → [85](#) for transmitters without local operation.

6. You can correct the middle line with the arc length determined.

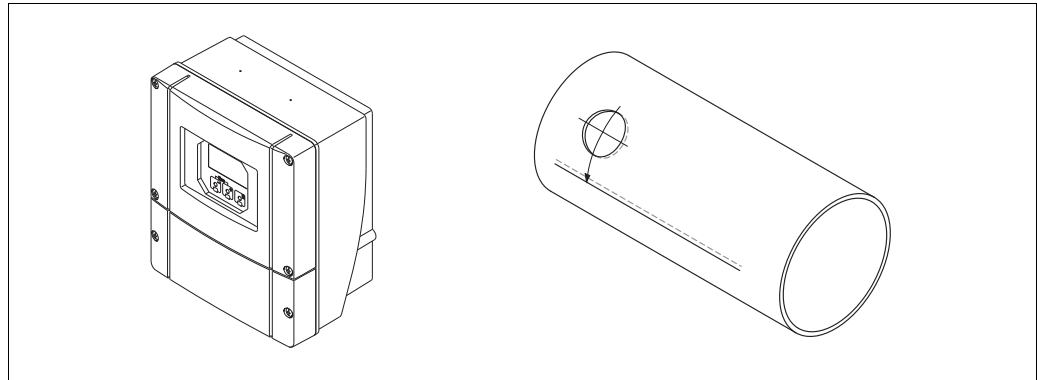

Fig. 55: Installing the dual-path measuring sensors, steps 5 and 6

7. Project the corrected middle line onto the other side of the pipe and draw this on (half pipe circumference).
8. Indicate the sensor distance on the middle line and project it onto the middle line on the back.

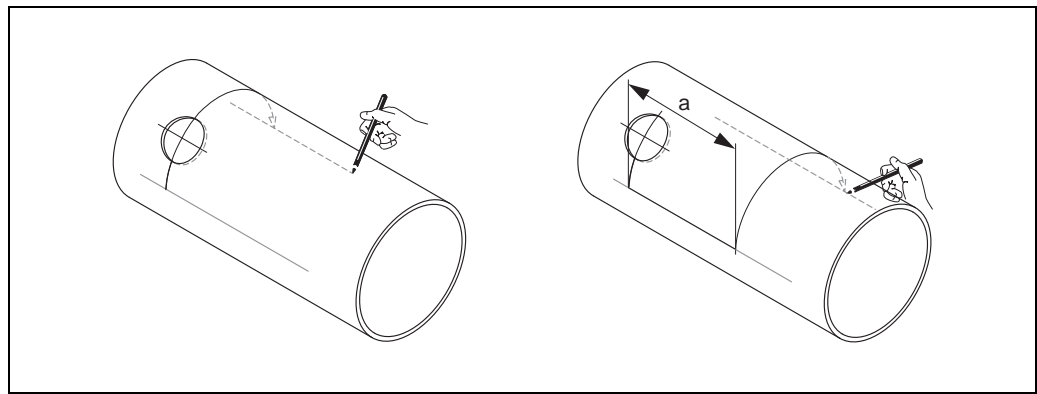



Fig. 56: Installing the dual-path measuring sensors, steps 7 and 8

9. Extend the arc length to each side of the middle line and indicate the drillholes.
10. Create the drillholes and prepare the holes for welding in the sensor holder (deburr, clean, etc.).

 Note!

Drillholes for the sensor holders always come in pairs (CH 1 - CH 1 and CH 2 - CH 2).

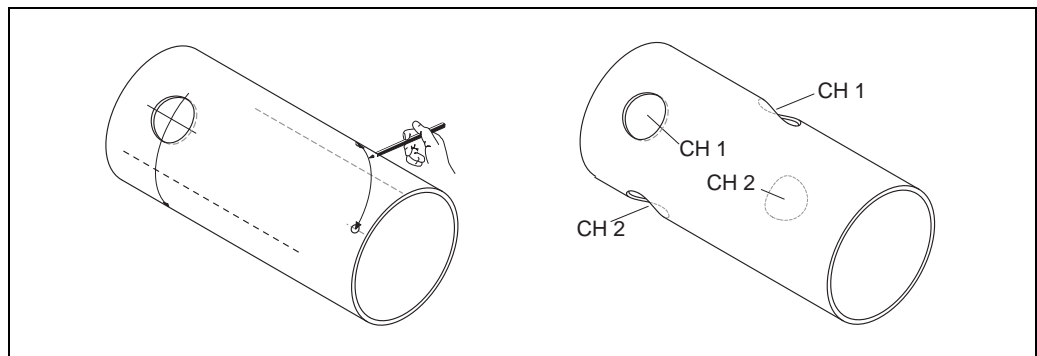



Fig. 57: Installing the dual-path measuring sensors, steps 9 and 10

11. Insert the sensor holders into the first pair of drillholes and align with the tie rod (alignment tool). Spot-weld with the wedding apparatus and then permanently weld both sensor holders.

 **Note!**

To align the tie rod, two guide bushings must be screwed onto the sensor holders.

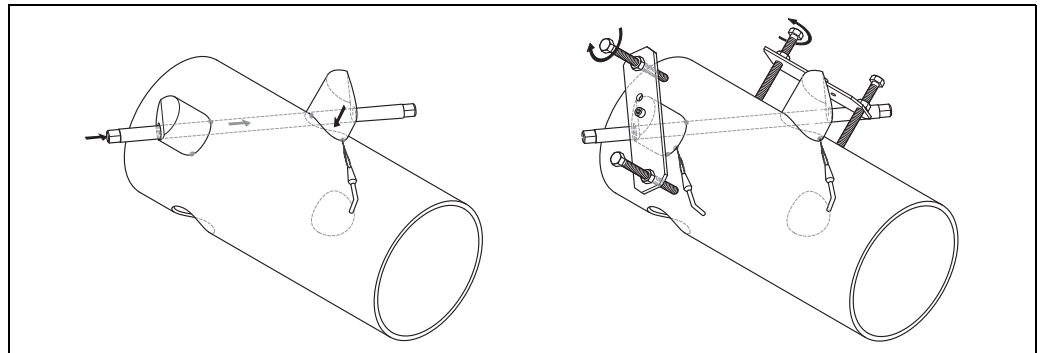

Fig. 58: Installing the dual-path measuring sensors, step 11

12. Weld in both sensor holders.
13. Check the path length, sensor distances and arc lengths once again.

 **Note!**

These distances are given as a measurement in Quick Setup. If you determine deviations, note these down and enter them as correction factors when commissioning the measuring point.

14. Insert the second pair of sensor holders into the two remaining drillholes, as described in step 12 .

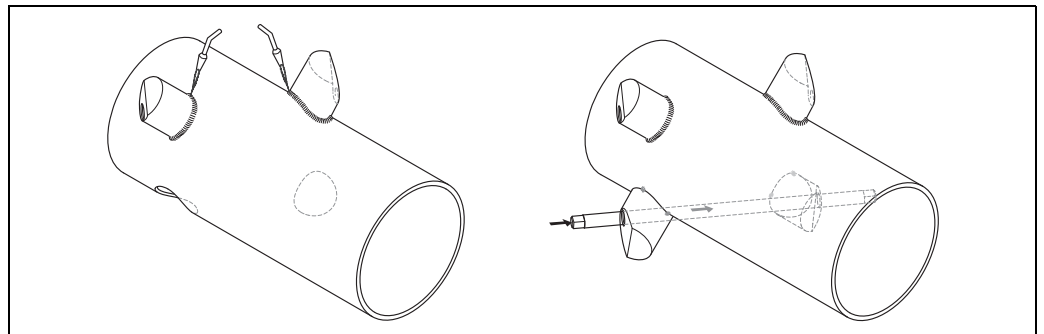

Fig. 59: Installing the dual-path measuring sensors, steps 13 and 14

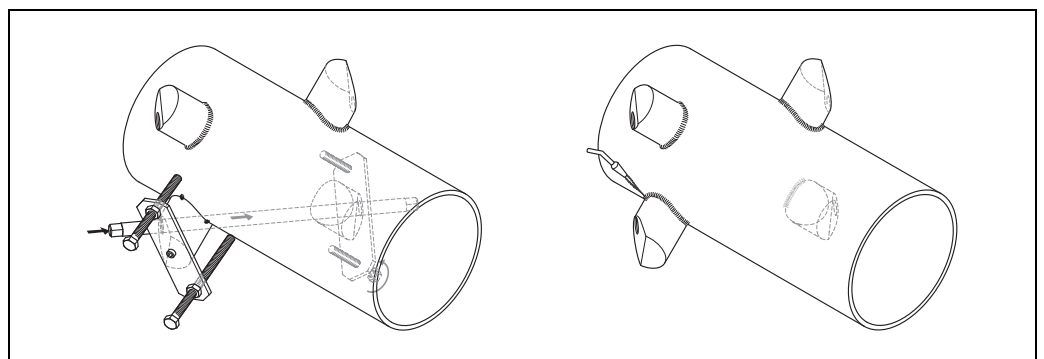

Fig. 60: Installing the dual-path measuring sensors, step 13

15. Then screw the sensors into the sensor holders by hand. If you use a tool, the maximum torque permissible is 30 Nm.
16. Insert the sensor cable connectors into the opening provided and manually tighten the connectors to the stop.

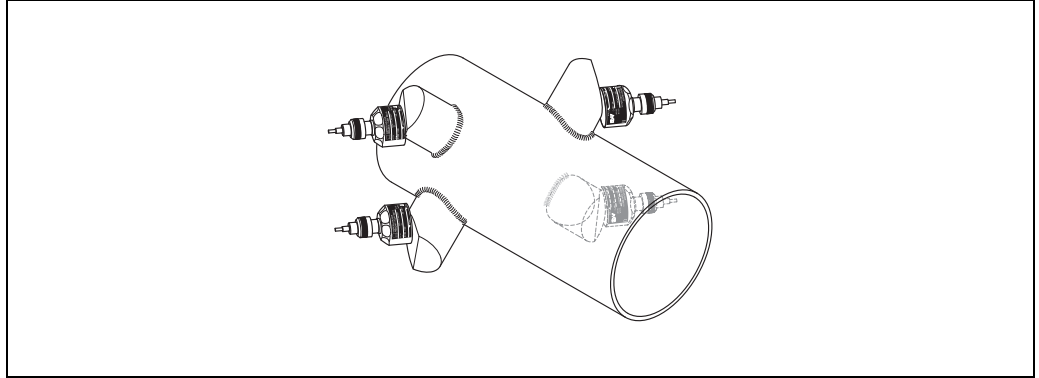

Fig. 61: Installing the dual-path measuring sensors, step 14 and 15

A0001169

3.12 Installing sensor DDU18

1. Premount the strapping band:
 - Nominal diameters $DN \leq 200$ (8") → 32
 - Nominal diameters $DN > 200$ (8") → 33
 The two mounting bolts must be positioned opposite each other on either side of the pipe.
2. Fit the sensor holders over the individual mounting bolts and tighten securely with the retaining nut.
3. Coat the contact surfaces of the sensors with an even layer of coupling fluid approx. 1 mm (0.04") thick, going from the groove through the center to the opposite edge.
4. Insert the sensor into the sensor holder.
5. Fit the sensor cover on the sensor holder and turn until:
 - The sensor cover engages with a click
 - The arrows (▲ / ▼ "close") are pointing towards one another.
6. Screw the connecting cable into the individual sensor.

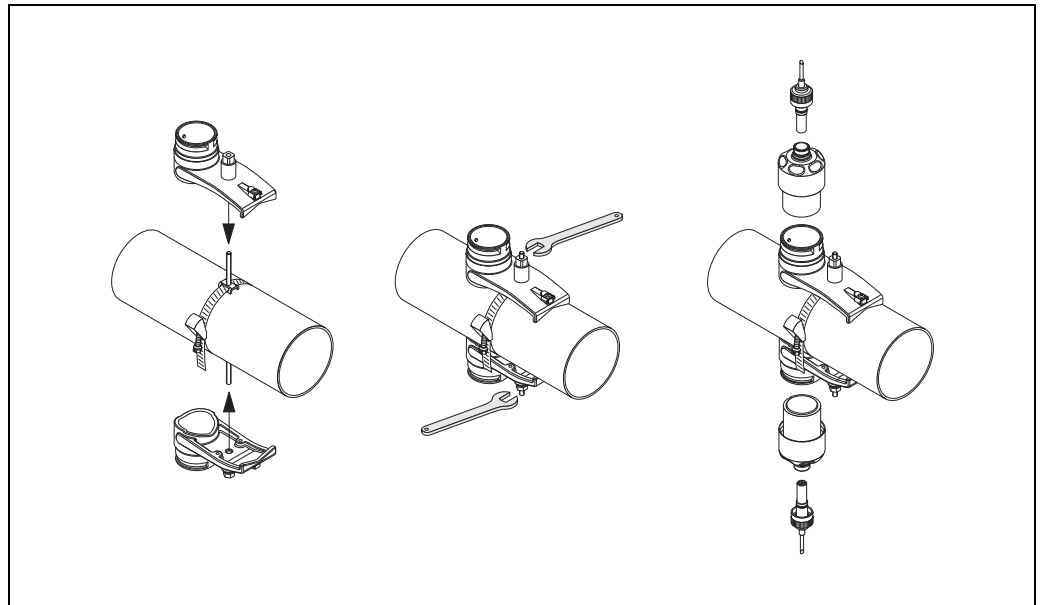

Fig. 62: Steps 1 to 5, installing the sound velocity measuring sensors

A0001171

3.13 Installing sensor DDU19

3.13.1 Version 1

1. Premount the strapping band:
 - Nominal diameters $DN \leq 200$ (8") → 32
 - Nominal diameters $DN > 200$ (8") → 33
 The two mounting bolts must be positioned opposite each other on either side of the pipe.
2. Fit the sensor holders over the individual mounting bolts and tighten securely with the retaining nut.
3. Coat the contact surfaces of the sensors with an even layer of coupling fluid approx. 1 mm (0.04") thick, going from the groove through the center to the opposite edge.
4. Insert the sensor into the sensor holder.
5. Fit the sensor cover on the sensor holder and turn until:
 - The sensor cover engages with a click
 - The arrows (▲ / ▼ "close") are pointing towards one another.
6. Screw the connecting cable into the connections of the sensor.
7. After determining the pipe wall thickness, replace the wall thickness sensor DDU19 with the appropriate flow sensor.



Note!

Clean the coupling point carefully before the flow sensor coated with new coupling fluid is inserted.

3.13.2 Version 2

This is only suitable if the transmitter is within range of the measuring point.

1. Coat the contact surfaces of the sensors with an even layer of coupling fluid approx. 1 mm (0.04") thick, going from the groove through the center to the opposite edge.
2. Hold the sensor vertically by hand on the pipe for measurement. Operate the local operation with your other hand.

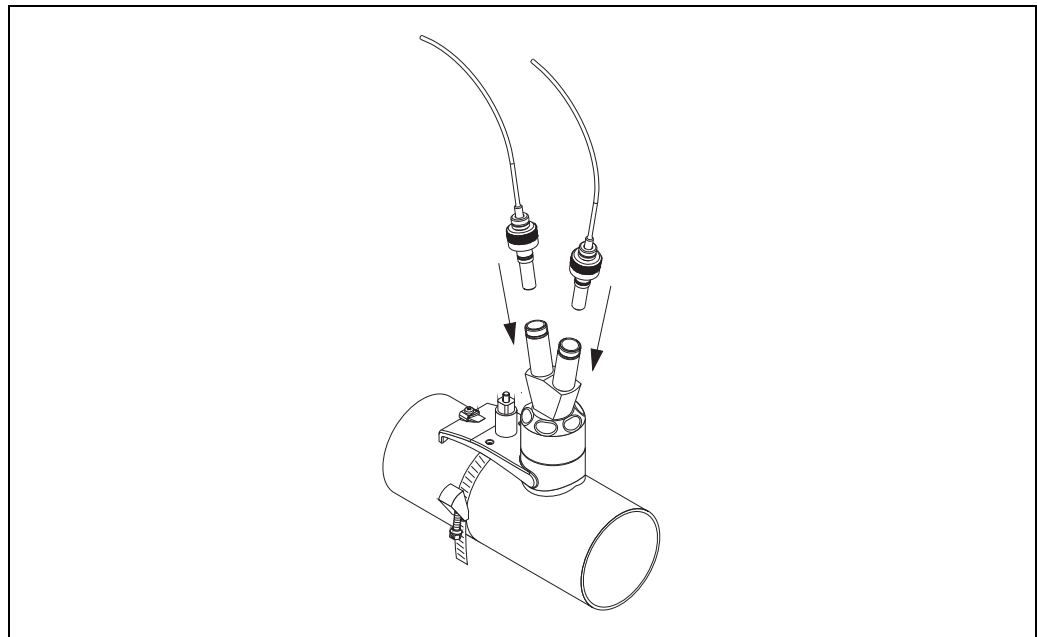

Fig. 63: Installing the wall thickness measuring sensor

3.14 Installing the wall-mount transmitter housing

There are various ways of installing the wall-mount housing:

- Direct wall mounting
- Panel mounting (with separate mounting kit, accessories) → [101](#)
- Pipe mounting (with separate mounting kit, accessories) → [101](#)



Caution!

- Make sure that the permitted operating temperature range (-20 to +60 °C / -4 to 140 °F) is not exceeded at the mounting location. Install the device in a shady location. Avoid direct sunlight.
- Always install the wall-mount housing in such a way that the cable entries are pointing down.

3.14.1 Direct wall mounting

1. Drill the holes → [55](#).
2. Remove the cover of the connection compartment (a).
3. Push the two securing screws (b) through the appropriate bores (c) in the housing.
 - Securing screws (M6): max. Ø 6.5 mm (0.26")
 - Screw head: max. Ø 10.5 mm (0.41")
4. Secure the transmitter housing to the wall as indicated.
5. Screw the cover of the connection compartment (a) firmly onto the housing.

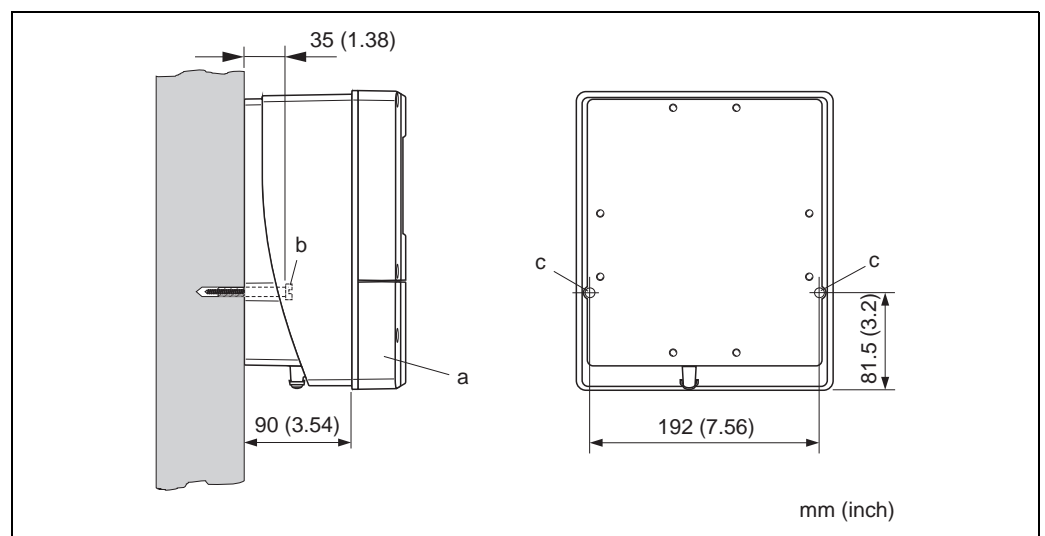



Fig. 64: Direct wall mounting

A0001130

3.14.2 Panel mounting

1. Prepare the opening in the panel →  65.
2. Slide the housing into the panel cutout from the front.
3. Screw the retainers onto the wall-mount housing.
4. Screw the threaded rods into the retainers and tighten until the housing is solidly seated on the panel wall. Tighten the counter nuts. No further support is necessary.

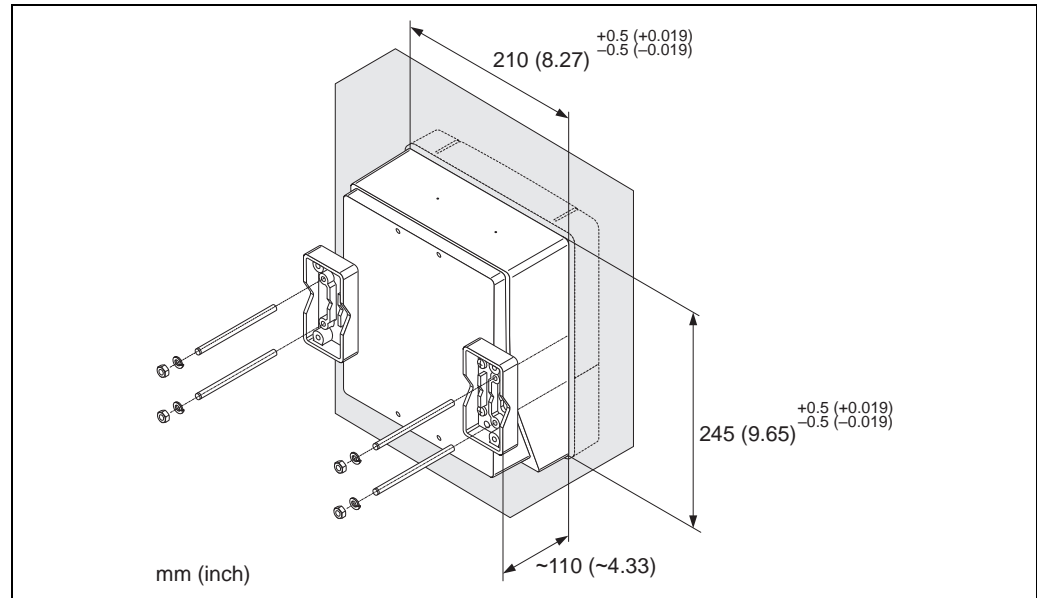



Fig. 65: Panel mounting (wall-mount housing)

3.14.3 Pipe mounting

The assembly should be performed by following the instructions on →  56.



Caution!

If a warm pipe is used for installation, make sure that the housing temperature does not exceed the max. permitted value of +60 °C (+140 °F).

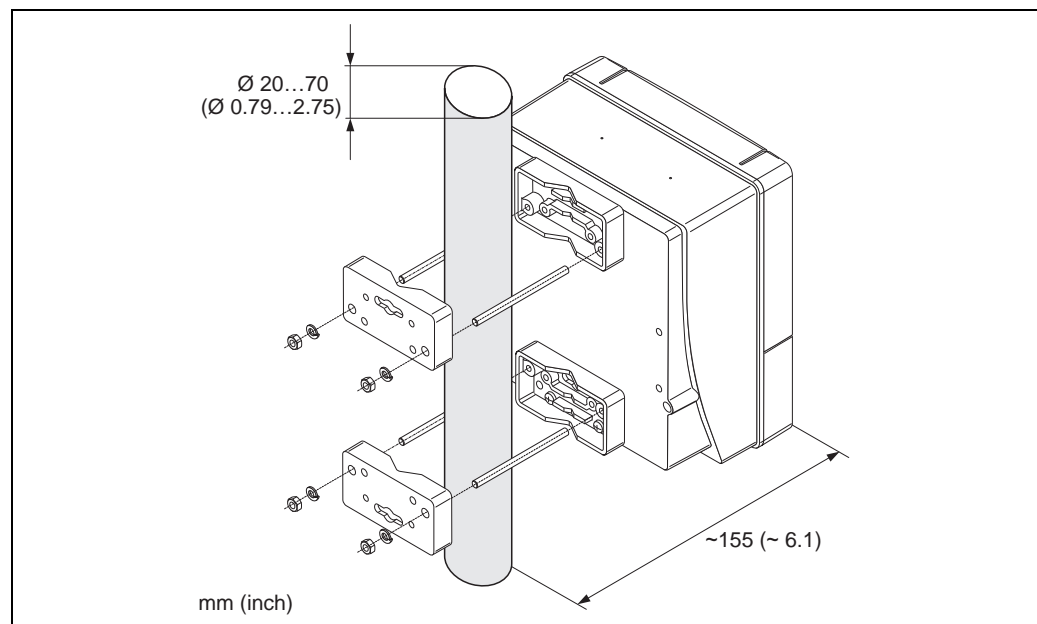

Fig. 66: Pipe mounting (wall-mount housing)

3.15 Post-installation check

Perform the following checks after installing the measuring device on the pipe:

Device condition and specifications	Notes
Is the device damaged (visual inspection)?	–
Does the device correspond to specifications at the measuring point, including process temperature, ambient temperature, measuring range, etc.?	→ 125
Installation	Notes
Are the measuring point number and labeling correct (visual inspection)?	–
Process environment / process conditions	Notes
Have the inlet and outlet runs been observed?	→ 12
Is the measuring device protected against moisture and direct sunlight?	–

4 Wiring



Warning!

When connecting Ex-certified devices, please refer to the notes and diagrams in the Ex-specific supplement to these Operating Instructions. Please do not hesitate to contact your Endress+Hauser sales office if you have any questions.

4.1 Sensor/transmitter connecting cable



Warning!

- Risk of electric shock. Switch off the power supply before opening the device. Do not install or wire the device while it is connected to the power supply. Failure to comply with this precaution can result in irreparable damage to the electronics.
- Risk of electric shock. Connect the protective ground to the ground terminal on the housing before the power supply is applied.



Note!

To ensure correct measuring results, route the cable well clear of electrical machines and switching elements.

4.1.1 Connecting and grounding Prosonic Flow W and P (DN 50 to 4000 / 2 to 160") Two Single coaxial cables

Procedure → 59

1. Remove the cover (a) of the connection compartment.
2. Remove the dummy cover from the cable entry (b).
3. Route the two connecting cables (c) of channel 1 through the cable gland (d).
4. Route the two connecting cables of channel 1 through the cable entry (b) and into the connection compartment of the transmitter.
5. Place the cable retaining sleeves (e) of the two connecting cables at the ground contact terminals (f) (Detail B).
6. Twist down the ground contact terminals (f) so that the two cable retaining sleeves (e) are firmly seated.
7. Screw the ground contact terminals (f) tight.



Note!

The Prosonic Flow W and Prosonic Flow P DN 15 to 65 (½ to 2½") is grounded via the cable gland → 60.

8. Connect the connecting cable:
 - Channel 1 upstream = 1
 - Channel 1 downstream = 2
 - Channel 2 upstream = 3
 - Channel 3 downstream = 4
9. Spread the rubber seal (g) along the side slit with a suitable tool (e.g. a large screwdriver) and fix both connecting cables into place.
10. Push the rubber seal (g) up into the cable entry (b).
11. Tighten the cable gland (d).
12. Fit the cover (a) on the connection compartment and screw it on.



Note!

The connection compartment does not have to be assembled if the transmitter is wired (power supply and signal cable) directly afterwards.

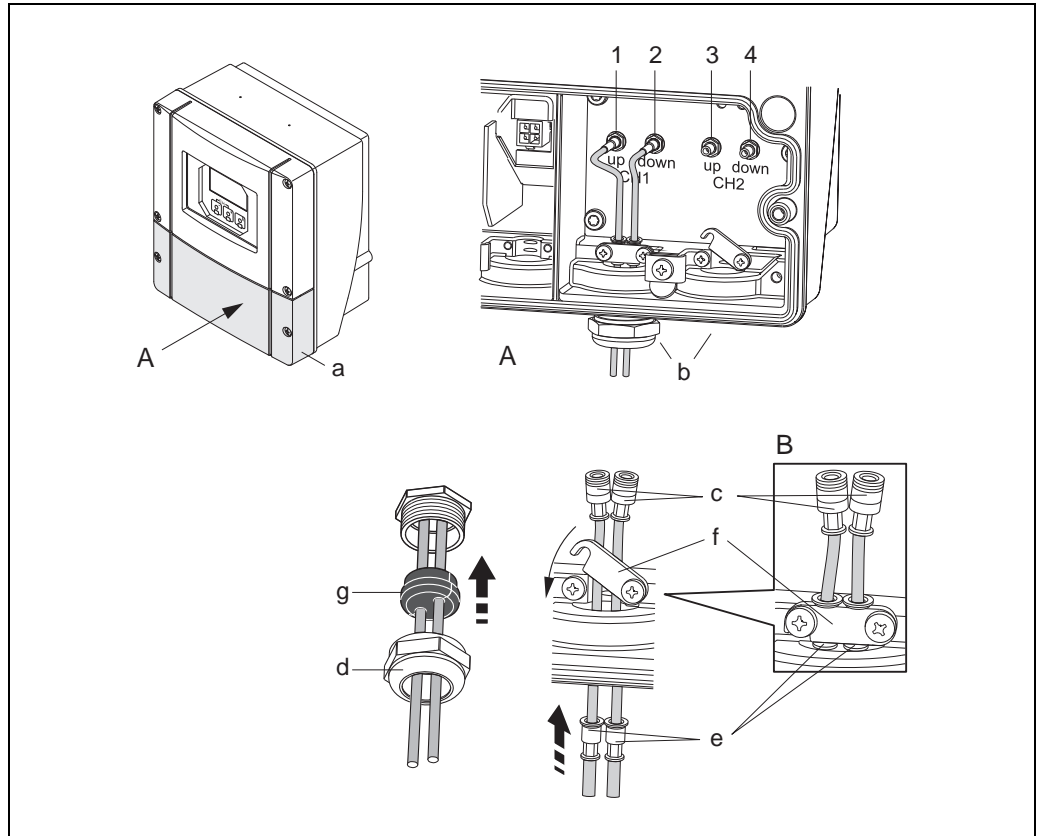

Fig. 67: Connecting the connecting cable for sensor/transmitter (with cable gland for two connecting cables per cable entry)

- A View A
- B Detail B
- 1 Sensor cable connector, channel 1 upstream
- 2 Sensor cable connector, channel 1 downstream
- 3 Sensor cable connector, channel 2 upstream
- 4 Sensor cable connector, channel 2 downstream
- a Connection compartment cover
- b Cable entries
- c Connecting cables
- d Cable gland
- e Cable retaining sleeves
- f Ground contact terminals (only Prosonic Flow P DN 50 to 4000 / 2 to 160", for grounding of the Prosonic Flow P DN 15 to 65 / 1/2 to 2 1/2", see next section)
- g Rubber seal

4.1.2 Connecting and Grounding Prosonic Flow W and Prosonic Flow P DN 15 to 65 (½ to 2½") Multicore cable

The Prosonic Flow W/P DN 15 to 65 (½ to 2½") is grounded via the cable gland.

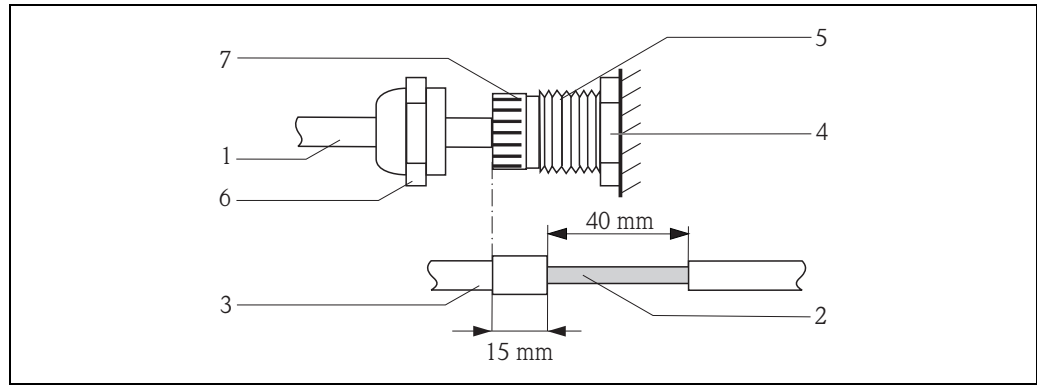

Fig. 68: Connecting and grounding the measuring system

- A Cable sheath
- B Bared braided screen (pre-prepared)
- C Rubber grommet
- D Internal contact point for the grounding on this level (External inspection not possible)
- E Cable gland
- F Cable gland cover
- G Grounding mechanism

Procedure

1. Screw the cable gland (E) into the transmitter housing.
2. Guide the sensor connecting cables through the cable gland cover (F).
3. Thread the sensor connecting cables into the transmitter housing.
Align the outer end of the rubber grommet with the end of the cable gland/grounding mechanism. This ensures that the cable entry will be a) tight and b) the cable is correctly grounded to the transmitter housing at the internal contact point (D) once tightened. An external inspection is not possible, so it is important to follow this instruction.
4. Tighten the cable gland by turning the cable gland cover clockwise.



Note!

The red marked cable is sensor "up"; the blue marked cable is sensor "down".



Note!

The cable gland can be released from the cable by unscrewing and removing the cable gland cover. Then retract the grounding mechanism (G) with a pair of pliers. The retraction of the mechanism does not require strong force (strong force might destroy the screen). It might be required to lift the internal hooks of the grounding mechanism out of a locked position by pressing the grounding mechanism further forward by turning the cable gland clockwise. Remove the cable gland cover again. Then retry to retract with the pair of pliers.

4.1.3 Cable specification for connecting cable

Only use the connecting cables supplied by Endress+Hauser.
The connecting cables are available in different lengths → 101.
For the cable specifications, see → 122.

Operation in areas with strong electrical interference

The measuring system complies with the general safety requirements in accordance with EN 61010, the EMC requirements of IEC/EN 61326 "Emission as per Class A requirements" and NAMUR Recommendation NE 21.

4.2 Connecting the measuring unit

4.2.1 Connecting the transmitter



Warning!

- Risk of electric shock. Switch off the power supply before opening the device. Do not install or wire the device while it is connected to the power supply. Failure to comply with this precaution can result in irreparable damage to the electronics.
 - Risk of electric shock. Connect the protective ground to the ground terminal on the housing before the power supply is applied (not required for galvanically isolated power supply).
 - Compare the specifications on the nameplate with the local supply voltage and frequency. Furthermore, the national regulations governing the installation of electrical equipment also apply.
1. Unscrew the connection compartment cover (f) from the transmitter housing.
 2. Route the power supply cable (a) and signal cable (b) through the appropriate cable entries.
 3. Wire the unit:
 - Wiring diagram (wall-mount housing) → 61
 - Terminal assignment → 62
 4. Screw the cover of the connection compartment (f) back onto the transmitter housing.

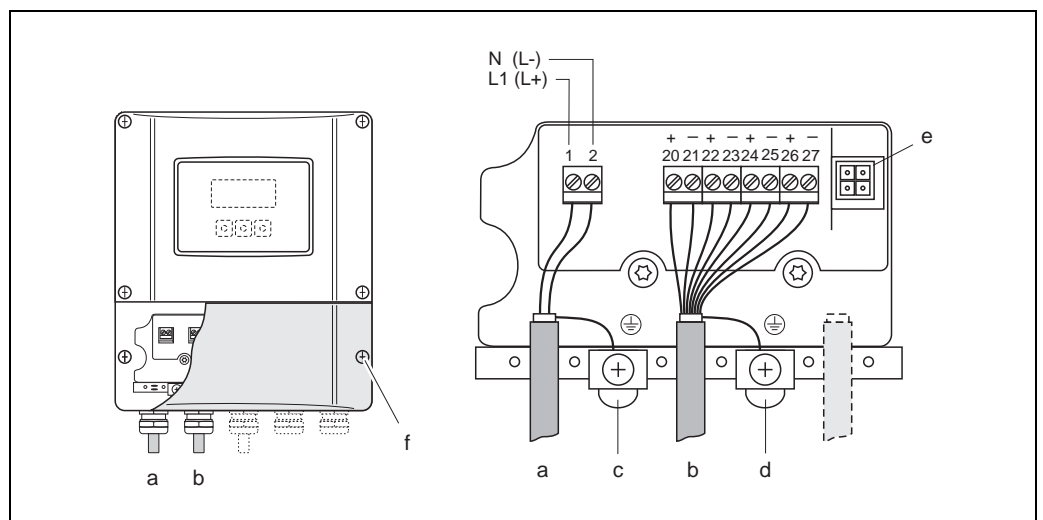

Fig. 69: Connecting the transmitter (wall-mount housing). Cable cross-section: max. 2.5 mm² (14 AWG)

- a Cable for power supply: 85 to 260 V AC, 20 to 55 V AC, 16 to 62 V DC
Terminal **No. 1**: L1 for AC, L+ for DC
Terminal **No. 2**: N for AC, L- for DC
- b Signal cable: Terminals **No. 20–27** → 62
- c Ground terminal for protective ground
- d Ground terminal for signal cable shield
Service adapter for connecting service interface FXA193 (FieldCare)
- f Connection compartment cover

4.2.2 Terminal assignment

The inputs and outputs on the communication board can be either permanently assigned (fixed) or variable (flexible), depending on the version ordered (see table). Replacements for modules which are defective or which have to be replaced can be ordered as accessories.

Order variant	Terminal No. (inputs/outputs)			
	20 (+) / 21 (-)	22 (+) / 23 (-)	24 (+) / 25 (-)	26 (+) / 27 (-)
<i>Fixed communication boards (fixed assignment)</i>				
93***_*****A	–	–	Frequency output	Current output HART
93***_*****B	Relay output 2	Relay output 1	Frequency output	Current output HART
93***_*****F ¹	–	–	–	PROFIBUS PA, Ex i
93***_*****G ¹	–	–	–	FOUNDATION Fieldbus, Ex i
93***_*****H	–	–	–	PROFIBUS PA
93***_*****J	–	–	–	PROFIBUS DP
93***_*****K	–	–	–	FOUNDATION Fieldbus
93***_*****S ¹	–	–	Frequency output, Ex i	Current output, Ex i, passive, HART
93***_*****T ¹	–	–	Frequency output, Ex i	Current output, Ex i, passive, HART
<i>Flexible communication boards</i>				
93***_*****C	Relay output 2	Relay output 1	Frequency output	Current output HART
93***_*****D	Status input	Relay output	Frequency output	Current output HART
93***_*****L	Status input	Relay output 2	Relay output 1	Current output HART
93***_*****M	Status input	Frequency output	Frequency output	Current output HART
93***_*****P	Current output	Frequency output	Status input	PROFIBUS DP
93***_*****V	Relay output 2	Relay output 1	Status input	PROFIBUS DP
93***_*****W	Relay output	Current output	Current output	Current output HART
93***_*****2	Relay output	Current output	Frequency output	Current output HART
93***_*****4	Current input	Relay output	Frequency output	Current output HART
93***_*****6	Relay output	Relay output	Current output	Current output HART

¹ These options available for Prosonic Flow 93P only.

4.2.3 HART connection

Users have the following connection options at their disposal:

- Direct connection to transmitter via terminals 26 / 27
- Connection via the 4 to 20 mA circuit.*



Note!

- The measuring circuit's load must be at least 250 Ω.
- Make the following settings after commissioning:
 - CURRENT SPAN function → "4 to 20 mA HART" or "4 to 20 mA (25 mA) HART"
 - Switch HART write protection on or off → 96.

Connecting the HART handheld terminal

For the connection, also refer to the documentation issued by the HART Communication Foundation, and in particular HCF LIT 20: "HART, a technical summary".

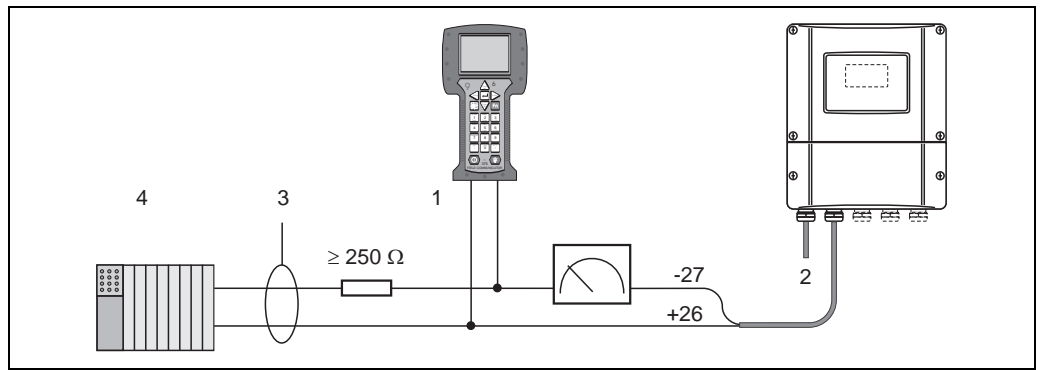

Fig. 70: Electrical connection to the HART operating terminal

- 1 HART operating terminal
- 2 Power supply
- 3 Shielding
- 4 Additional switching units or PLC with passive input

Connecting a PC with operating software

A HART modem (e.g. "Commubox FXA195") is required for connecting a PC with operating software (e.g. "FieldCare").

For the connection, also refer to the documentation issued by the HART Communication Foundation, and in particular HCF LIT 20: "HART, a technical summary".

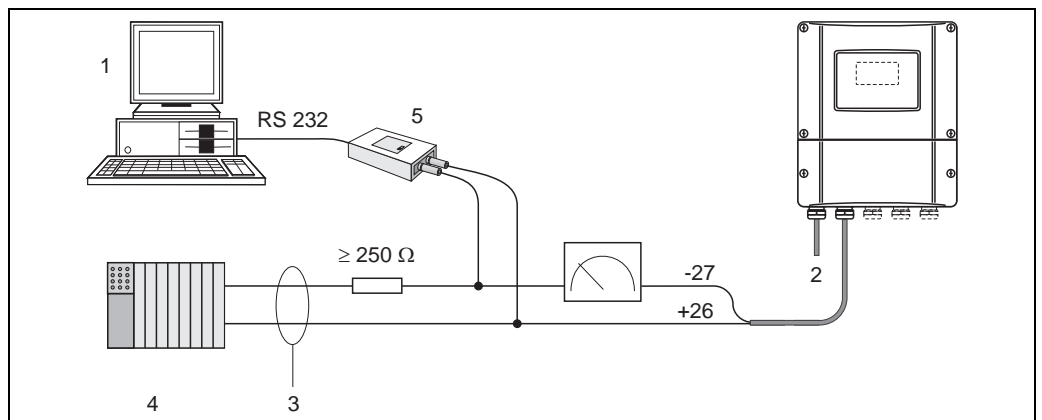

Fig. 71: Electrical connection of a PC with operating software

- 1 PC with operating software
- 2 Power supply
- 3 Shielding
- 4 Additional switching units or PLC with passive input
- 5 HART modem e.g. Commubox FXA195

4.3 Potential equalization

No special measures are necessary for potential equalization.



Note!

For devices for use in hazardous areas, observe the corresponding guidelines in the specific Ex documentation.



Note!

The cable screen(s) are not allowed to be used for potential equalization.

4.4 Degree of protection

Transmitter (wall-mount housing)

The transmitter fulfills all the requirements for IP 67.

Compliance with the following points is mandatory following installation in the field or servicing, in order to ensure that IP 67 protection is maintained:

- The housing seals must be clean and undamaged when inserted into their grooves. The seals must be greased, cleaned or replaced if necessary.
- All the threaded fasteners and screw covers must be firmly tightened.
- The cables used for connection must be of the specified outside diameter → 61.
- Securely tighten the cable entries → 64.
- Remove all unused cable entries and insert plugs instead.
- Do not remove the grommet from the cable entry.

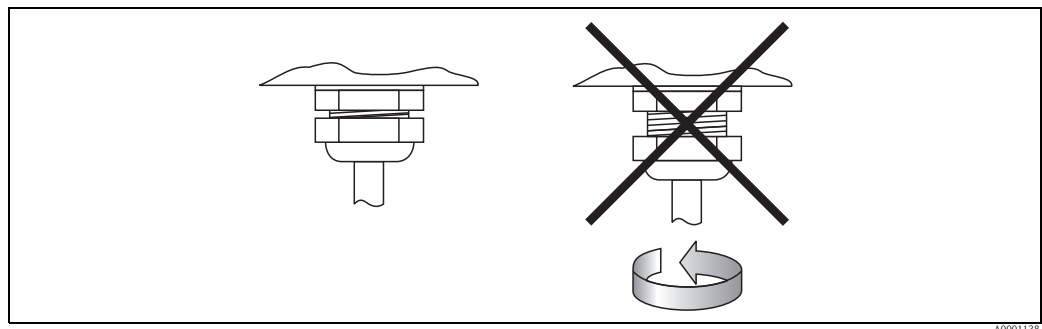

Fig. 72: Installation instructions for cable entries on the transmitter housing

Prosonic Flow P and W sensor (Clamp-on / Insertion version), DDU 18

The flowrate sensors Prosonic Flow P and W, as well as the sound velocity sensors DDU 18, meet all the requirements for IP 67 or IP 68 degree of protection (please observe the information on the nameplate of the sensor).

Compliance with the following points is mandatory following installation in the field or servicing, in order to ensure that IP 67/68 protection is maintained:

- Only use connecting cables supplied by Endress+Hauser with the corresponding cable connectors.
- When connecting, do not jam the cable connectors. Tighten them to the stop.
- The cable connector seals must be clean, dry and undamaged when inserted in the seal groove → 65 (1).

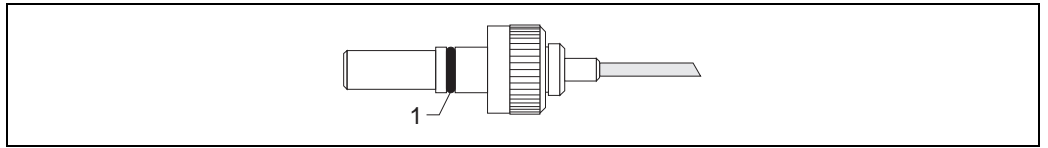

Fig. 73: Cable connector

1 Cable connector seal

4.5 Post-connection check

Perform the following checks after completing electrical installation of the measuring device:

Device condition and specifications	Notes
Are cables or the device damaged (visual inspection)?	–
Electrical connection	Notes
Does the supply voltage match the specifications on the nameplate?	85 to 260 V AC (45 to 65 Hz) 20 to 55 V AC (45 to 65 Hz) 16 to 62 V DC
Do the cables comply with the specifications?	→ 61
Is the cable type route completely isolated?	–
Is the cable type route completely isolated? Without loops and crossovers?	–
Are the power supply and signal cables correctly connected?	See the wiring diagram inside the cover of the terminal compartment
Are all screw terminals firmly tightened?	–
Have all measures regarding grounding and potential equalization been implemented correctly?	
Are all cable entries installed, firmly tightened and correctly sealed?	→ 65
Are all the housing covers installed and tightened?	–

5 Operation

5.1 Quick operation guide

You have a number of options for configuring and commissioning the device:

1. Local display (option) → 66
The local display enables you to read all of the important parameters directly at the measuring point, configure device-specific parameters in the field and commission the instrument.
2. Configuration program → 73
The FieldCare configuration software facilitates the commissioning of devices without local operation.

5.2 Display and operating elements

The local display enables you to read all important parameters directly at the measuring point and configure the device using the "Quick Setup" or the function matrix.

The display area consists of four lines; this is where measured values are displayed, and/or status variables (direction of flow, bar graph, etc.). You can change the assignment of display lines to different variables to suit your needs and preferences (→ "Description of Device Functions" manual).

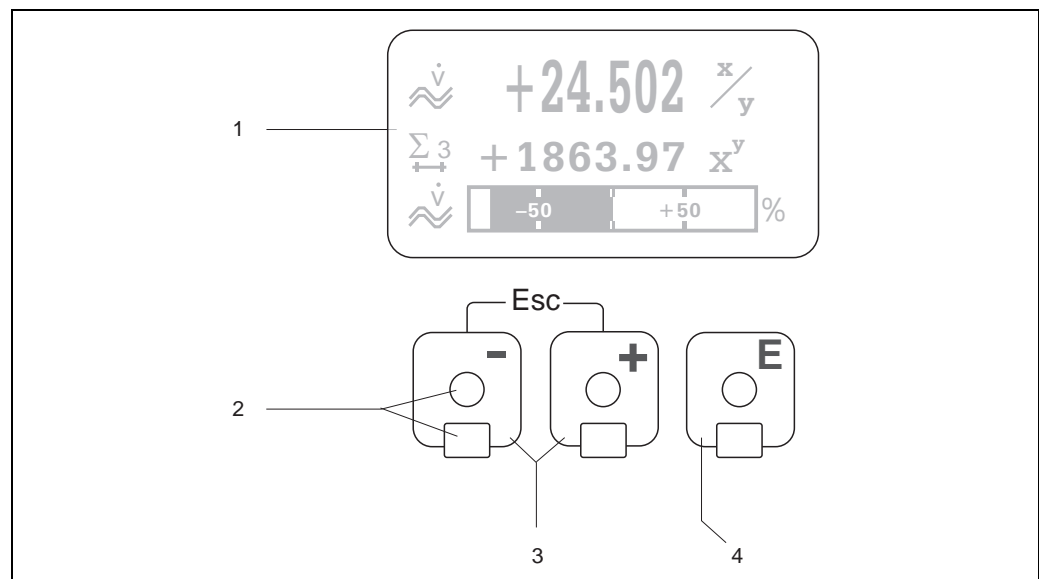

Fig. 74: Display and operating elements

Liquid crystal display (1)

The backlit, four-line liquid-crystal display shows measured values, dialog texts, error messages and notice messages. The display as it appears when normal measuring is in progress is known as the HOME position (operating mode).

Optical sensors for "Touch Control" (2)

2 Plus/minus keys (3)

- HOME position → Direct access to totalizer values and actual values of inputs/outputs
- Enter numerical values, select parameters
- Select different blocks, groups and function groups within the function matrix

Press the \square \square keys simultaneously to trigger the following functions:

- Exit the function matrix step by step → HOME position
- Press and hold down the \square \square keys for longer than 3 seconds → Return directly to HOME position
- Cancel data entry

3 Enter key (4)

- HOME position → Entry into the function matrix
- Save the numerical values you input or settings you change

Display (operating mode)

The display area consists of three lines in all; this is where measured values are displayed, and/or status variables (direction of flow, bar graph, etc.). You can change the assignment of display lines to different variables to suit your needs and preferences (→ "Description of Device Functions" manual).

Multiplex mode:

A maximum of two different display variables can be assigned to each line. Variables multiplexed in this way alternate every 10 seconds on the display.

Error messages:

In-depth information on how system/process errors are displayed is provided on → [106 ff.](#)

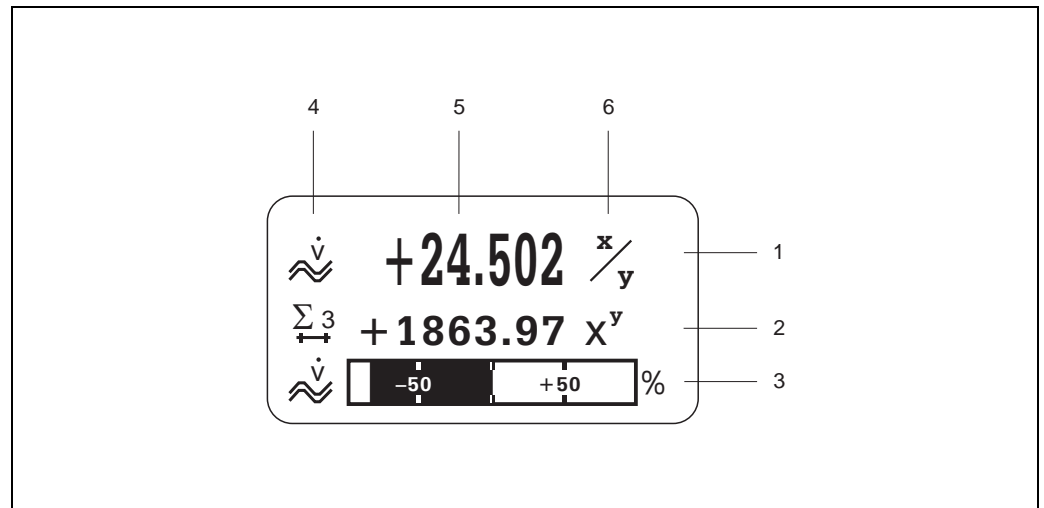

Fig. 75: Typical display for standard operating mode (HOME position)

- 1 Main line: shows main measured values, e.g. volume flow in [l/s].
- 2 Additional line: shows additional measured variables and status variables, e.g. totalizer reading No. 3 in [m3].
- 3 Information line: shows additional information on the measured variables and status variables, e.g. bar graph display of the end value achieved by the volume flow.
- 4 "Info icons" field: icons representing additional information on the measured values are shown in this field. A full overview of all the symbols and their meaning is provided on → [68](#).
- 5 "Measured values" field: the current measured values appear in this field.
- 6 "Unit of measure" field: the units of measure and time defined for the current measured values appear in this field.



Note!

From the HOME position, you can use the $\boxed{+}$ $\boxed{-}$ keys to open an "Info Menu" containing the following information:











- Totalizers (including overflow)
- Actual values or states of the configured inputs/outputs
- Device TAG number (user-definable).

$\boxed{+}$ $\boxed{-}$ key → Scan of individual values within the list

Esc key ($\boxed{\text{Esc}}$) → Return to HOME position

Icons

The icons which appear in the field on the left make it easier to read and recognize measured variables, device status, and error messages.

Icon	Meaning	Icon	Meaning
S	System error	P	Process errors
	Fault message (with effect on outputs)	!	Notice message (without effect on outputs)
I 1 to n	Current output 1 to n	P 1 to n	Pulse output 1 to n
F 1 to n	Frequency output 1 to n	S 1 to n	Status output/relay output 1 to n (or status input)
Σ 1 to n	Totalizer 1 to n	 A0013672	Signal strength
 A0001181	Measuring mode: PULSATING FLOW	 A0001182	Measuring mode: SYMMETRY (bidirectional)
 A0001183	Measuring mode: STANDARD	 A0001184	Totalizer count mode: BALANCE (forward and backward)
 A0001185	Totalizer count mode: Forward	 A0001186	Totalizer count mode: Backward
 A0001187	Signal input (current input or status input)	 A0001188	Volume flow
 A000xxxx	Device operation active		

5.3 Brief guide to the function matrix



Note!

- See the general notes → 70.
- Function descriptions → see the "Description of Device Functions" manual"

1. HOME position → **E** → Entry into the function matrix
2. Select a block (e.g. OUTPUTS)
3. Select a group (e.g. CURRENT OUTPUT 1)
4. Select a function group (e.g. CONFIGURATION)
5. Select a function (e.g. TIME CONSTANT)

Change parameter / enter numerical values:

+ - → Select or enter enable code, parameters, numerical values

E → Save your entries

6. Exit the function matrix:

- Press and hold down Esc key (**Esc**) for longer than 3 seconds → HOME position
- Repeatedly press Esc key (**Esc**) → Return step-by-step to HOME position.

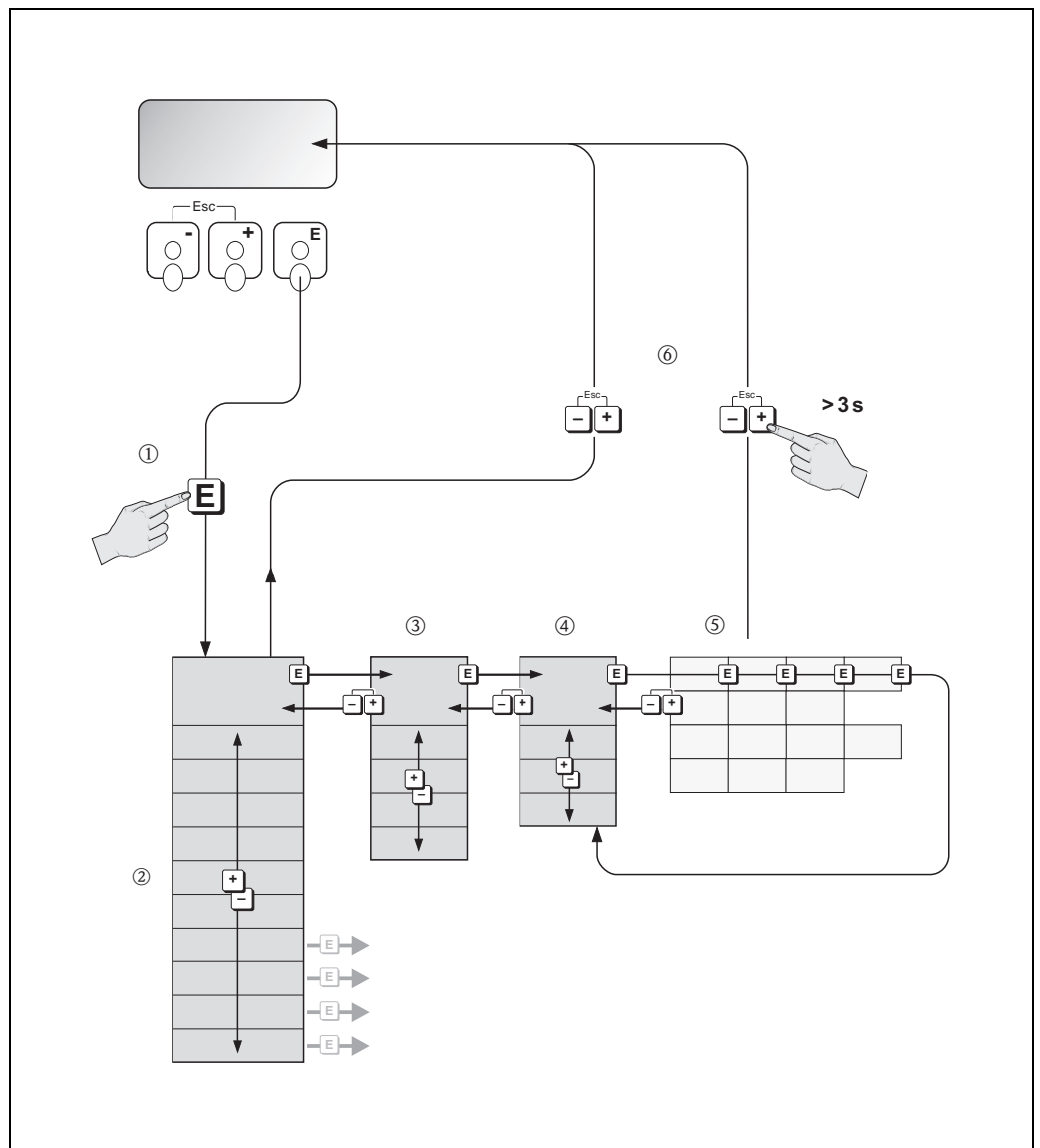







Fig. 76: Selecting functions and configuring parameters (function matrix)

A0001210

5.3.1 General notes

The Quick Setup menu (→  85) contains the default settings that are adequate for commissioning. Complex measuring operations on the other hand necessitate additional functions that you can configure as necessary and customize to suit your process parameters. The function matrix, therefore, comprises a multiplicity of additional functions which, for the sake of clarity, are arranged on a number of menu levels (blocks, groups, and function groups).

Comply with the following instructions when configuring functions:

- You select functions as described on →  69. Each cell in the function matrix is identified by a numerical or letter code on the display.
- You can switch off certain functions (OFF). If you do so, related functions in other function groups will no longer be displayed.
- Certain functions prompt you to confirm your data entries.
Press   to select "SURE | YES]" and press  to confirm. This saves your setting or starts a function, as applicable.
- Return to the HOME position is automatic if no key is pressed for 5 minutes.



Note!

- The transmitter continues to measure while data entry is in progress, i.e. the current measured values are output via the signal outputs in the normal way.
- If the power supply fails all preset and parameterized values remain safely stored in the EEPROM.



Caution!



All functions are described in detail, as is the function matrix itself, in the "Description of Device Functions" manual which is a separate part of these Operating Instructions.

5.3.2 Enabling the programming mode

The function matrix can be disabled. Disabling the function matrix rules out the possibility of inadvertent changes to device functions, numerical values or factory settings. A numerical code (factory setting = 80) has to be entered before settings can be changed.

If you use a code number of your choice, you exclude the possibility of unauthorized persons accessing data (→ "Description of Device Functions" manual).

Comply with the following instructions when entering codes:

- If programming is disabled and the   operating elements are pressed in any function, a prompt for the code automatically appears on the display.
- If "0" is entered as the private code, programming is always enabled.
- The Endress+Hauser service organization can be of assistance if you mislay your personal code.



Caution!

Changing certain parameters such as all sensor characteristics, for example, influences numerous functions of the entire measuring system, particularly measuring accuracy.

There is no need to change these parameters under normal circumstances and consequently, they are protected by a special code known only to the Endress+Hauser service organization. Please contact Endress+Hauser if you have any questions.

5.3.3 Disabling the programming mode

Programming mode is disabled if you do not press an operating element within 60 seconds following automatic return to the HOME position.

You can also disable programming in the "ACCESS CODE" function by entering any number other than the customer's code.

5.4 Error messages

5.4.1 Type of error

Errors that occur during commissioning or measuring are displayed immediately. If two or more system or process errors occur, the error with the highest priority is the only one shown on the display.

The measuring system distinguishes between two types of error:

- **System error:** this group includes all device errors, for example communication errors, hardware errors, etc. (→ 106).
- **Process error:** this group includes all application errors, e.g. measuring range exceeded (→ 110).

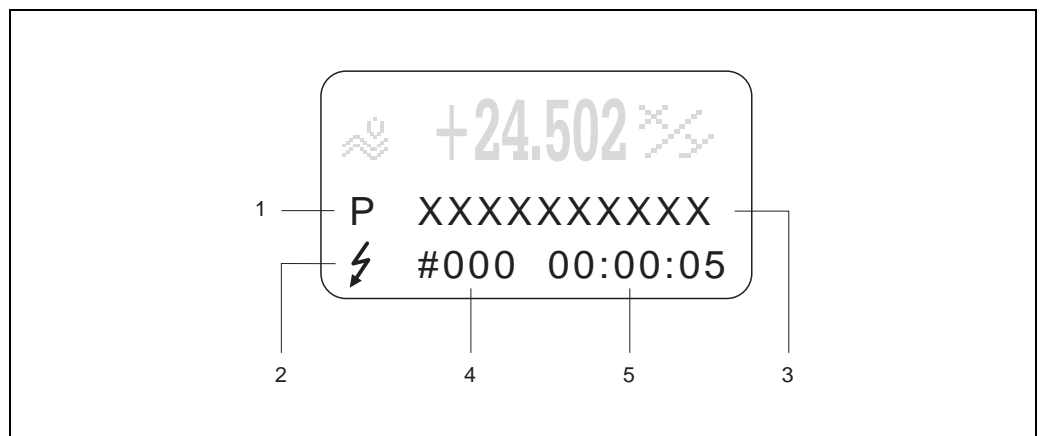

Fig. 77: Error messages on the display (example)

- 1 Error type: P = process error, S = system error
- 2 Error message type: ⚡ = fault message, ! = notice message, (definition: → 105).
- 3 Error designation: e.g. S. V. RANGE CH1. = sound velocity of channel 1 is outside the measuring range
- 4 Error number: e.g. #492
- 5 Duration of most recent error occurrence (in hours, minutes and seconds)

5.4.2 Error message types

Users have the option of weighting system and process errors differently, by defining them as either **Fault messages** or **Notice messages**. This is specified by means of the function matrix (see "Description of Device Functions" manual). Serious system errors, e.g. module defects, are always identified and classed as "fault messages" by the measuring device.

Notice message (!)

- Displayed as → Exclamation mark (!), error group (S: system error, P: process error).
- The error in question has no effect on the outputs of the measuring device.

Fault message (⚡)

- Displayed as → Lightning flash (⚡), error designation (S: system error, P: process error)
- The error in question has a direct effect on the outputs.

The response of the outputs (failsafe mode) can be defined by means of functions in the function matrix (→ 112).



Note!

- Error conditions can be output via the relay outputs.
- If an error message occurs, an upper or lower signal level for the breakdown information according to NAMUR NE 43 can be output via the current output.

5.4.3 Confirming error messages

For plant and process safety reasons, the measuring device can be configured in such a way that fault messages displayed (f) not only have to be eliminated but also have to be confirmed by pressing . Only then will error messages disappear from the display!

This function is enabled or disabled via the ACKNOWL. FAULTS function (→ "Description of Device Functions" manual).



Note!

- Fault messages (f) can also be reset and confirmed via the status input.
- Notice messages (!) do not have to be confirmed. However, they remain on the display until the cause for the error has been eliminated.

5.5 Communication (HART)

In addition to via local operation, the measuring device can also be configured and measured values obtained by means of the HART protocol. Digital communication takes place using the 4–20 mA HART current output (→  63).

The HART protocol allows the transfer of measuring and device data between the HART master and the field device for configuration and diagnostics purposes. HART masters, such as the handheld terminal or PC-based operating programs (such as FieldCare), require device description (DD) files. They are used to access all the information in a HART device. Such information is transferred solely via "commands". There are three different command classes:

Universal commands:

All HART devices support and use universal commands. These are associated with the following functionalities for example:

- Recognizing HART devices
- Reading off digital measured values (volume flow, totalizers, etc.)

Common practice commands:

Common practice commands offer functions which are supported and can be executed by many but not all field devices.

Device-specific commands:

These commands allow access to device-specific functions which are not HART standard. Such commands access individual field device information, (among other things), such as empty pipe/full pipe calibration values, low flow cutoff settings, etc.



Note!

The measuring device has all three command classes. A list of all the "Universal Commands" and "Common Practice Commands" supported is provided on →  75 ff.

5.5.1 Operating options

For the complete operation of the measuring device, including device-specific commands, device description (DD) files are available to the user for the following operating aids and programs:



Note!

- The HART protocol requires the "4 to 20 mA HART" or "4-20 mA (25 mA) HART" setting in the CURRENT SPAN function (current output 1).
- A jumper on the I/O board provides the means of activating or deactivating HART write protection.

HART handheld terminal FieldXpert

Selecting device functions with a HART Communicator is a process involving a number of menu levels and a special HART function matrix.

The HART operating instructions in the carrying case of the HART handheld terminal contain more detailed information on the device.

FieldCare

FieldCare is Endress+Hauser's FDT-based plant asset management tool and allows the configuration and diagnosis of intelligent field devices. By using status information, you also have a simple but effective tool for monitoring devices. The Proline flowmeters are accessed via a HART interface or via the service interface FXA193.

Operating program "SIMATIC PDM" (Siemens)

SIMATIC PDM is a standardized, manufacturer-independent tool for the operation, configuration, maintenance and diagnosis of intelligent field devices.

"AMS" operating program (Emerson Process Management)

AMS (Asset Management Solutions): program for operating and configuring devices.

5.5.2 Current device description files

The following table illustrates the suitable device description file for the operating tool in question and then indicates where this can be obtained.

HART protocol:

Valid for software:	2.02.XX	→ "Device software" function (8100)
HART device data		
Manufacturer ID:	11 _{hex} (ENDRESS+HAUSER)	→ "Manufacturer ID" function (6040)
Device ID:	59 _{hex}	→ "Device ID" function (6041)
HART version data:	Device Revision 6/ DD Revision 1	
Software release:	06.2009	
Operating program:	Sources for obtaining device descriptions:	
Handheld terminal FieldXpert	■ Use update function of handheld terminal	
FieldCare/DTM	<ul style="list-style-type: none"> ■ www.endress.com → Download ■ CD-ROM (Endress+Hauser order number 56004088) ■ DVD (Endress+Hauser order number 70100690) 	
AMS	■ www.endress.com → Download	
SIMATIC PDM	■ www.endress.com → Download	

Tester/simulator:	Sources for obtaining device descriptions:
Fieldcheck	■ Update via FieldCare with Flow Device FXA193/291 DTM in Fieldflash Module

5.5.3 Device variables and process variables

Device variables:

The following device variables are available via the HART protocol:

ID (decimal)	Device variable	ID (decimal)	Device variable
0	OFF (not assigned)	42	Average sound velocity
30	Volume flow channel 1	49	Flow velocity channel 1
31	Volume flow channel 2	50	Flow velocity channel 2
32	Average volume flow	51	Average flow velocity
33	Total volume flow	250	Totalizer 1
34	Volume flow diff	251	Totalizer 2
40	Sound velocity channel 1	252	Totalizer 3
41	Sound velocity channel 2		

Process variables:

The process variables are assigned to the following device variables at the factory:

- Primary process variable (PV) → Volume flow channel 1
- Secondary process variable (SV) → Totalizer 1
- Third process variable (TV) → Sound velocity channel 1
- Fourth process variable (FV) → Flow velocity channel 1











Note!

The assignment of the device variables to the process variable can be altered or specified via command 51 → 75.

5.5.4 Universal/common practice HART commands





The following table contains all the universal commands supported by the device.

Command No. HART command / access type		Command data (numeric data in decimal form)	Response data (numeric data in decimal form)
Universal commands			
0	Read the unique device identifier Access type = Read	None	The device identifier provides information on the device and manufacturer; it cannot be altered. The response consists of a 12-byte device ID: <ul style="list-style-type: none"> – Byte 0: fixed value 254 – Byte 1: manufacturer ID, 17 = E+H – Byte 2: device type ID, 89 = Prosonic Flow 93 – Byte 3: number of preambles – Byte 4: rev. no. universal commands – Byte 5: rev. no. device-spec. commands – Byte 6: software revision – Byte 7: hardware revision – Byte 8: additional device information – Byte 9-11: device identification
1	Read the primary process variable Access type = Read	None	<ul style="list-style-type: none"> – Byte 0: HART unit ID of the primary process variable – Byte 1-4: primary process variable <p><i>Factory setting:</i> Primary process variable = volume flow channel 1</p> <p> Note!</p> <ul style="list-style-type: none"> ■ The assignment of the device variables to the process variable can be specified via command 51. ■ Manufacturer-specific units are represented using the HART unit ID "240".
2	Read the primary process variable as current in mA and percentage of the set measuring range Access type = Read	None	<ul style="list-style-type: none"> – Byte 0-3: effective current of the primary process variable in mA – Byte 4-7: percentage of the set measuring range <p><i>Factory setting:</i> Primary process variable = volume flow channel 1</p> <p> Note! The assignment of the device variables to the process variable can be specified via command 51.</p>
3	Read the primary process variable as current in mA and four (preset using command 51) dynamic process variables Access type = Read	None	<p>24 bytes are sent as a response:</p> <ul style="list-style-type: none"> – Byte 0-3: current of the primary process variable in mA – Byte 4: HART unit ID of the primary process variable – Byte 5-8: primary process variable – Byte 9: HART unit ID of the secondary process variable – Byte 10-13: secondary process variable – Byte 14: HART unit ID of the third process variable – Byte 15-18: third process variable – Byte 19: HART unit ID of the fourth process variable – Byte 20-23: fourth process variable <p><i>Factory setting:</i></p> <ul style="list-style-type: none"> ■ Primary process variable = volume flow channel 1 ■ Secondary process variable = totalizer 1 ■ Third process variable = sound vel. channel 1 ■ Fourth process variable = flow vel. channel 2 <p> Note!</p> <ul style="list-style-type: none"> ■ The assignment of the device variables to the process variable can be specified via command 51. ■ Manufacturer-specific units are represented using the HART unit ID "240".

Command No. HART command / access type		Command data (numeric data in decimal form)	Response data (numeric data in decimal form)
6	Set HART short-form address Access type = Write	Byte 0: desired address (0 to 15) <i>Factory setting:</i> 0  Note! With an address > 0 (multidrop mode), the current output of the primary process variable is fixed to 4 mA.	Byte 0: active address
11	Read unique device identification using the TAG (measuring point designation) Access type = Read	Byte 0-5: TAG	The device identifier provides information on the device and manufacturer; it cannot be altered. The response consists of a 12-byte device ID if the TAG indicated matches the one saved in the device: <ul style="list-style-type: none"> - Byte 0: fixed value 254 - Byte 1: manufacturer ID, 17 = E+H - Byte 2: device type ID, 89 = Prosonic Flow 93 - Byte 3: number of preambles - Byte 4: rev. no. universal commands - Byte 5: rev. no. device-spec. commands - Byte 6: software revision - Byte 7: hardware revision - Byte 8: additional device information - Byte 9-11: device identification
12	Read user message Access type = Read	None	Byte 0-24: user message  Note! You can write the user message using command 17.
13	Read TAG, TAG description and date Access type = Read	None	- Byte 0-5: TAG - Byte 6-17: TAG description - Byte 18-20: date  Note! You can write the TAG, TAG description and date using command 18.
14	Read sensor information on the primary process variable	None	- Byte 0-2: serial number of the sensor - Byte 3: HART unit ID of the sensor limits and measuring range of the primary process variable - Byte 4-7: upper sensor limit - Byte 8-11: lower sensor limit - Byte 12-15: minimum span  Note! <ul style="list-style-type: none"> ■ The data relate to the primary process variable (= volume flow channel 1). ■ Manufacturer-specific units are represented using the HART unit ID "240".
15	Read output information of the primary process variable Access type = Read	None	- Byte 0: alarm selection ID - Byte 1: ID for transfer function - Byte 2: HART unit ID for the set measuring range of the primary process variable - Byte 3-6: end of measuring range, value for 20 mA - Byte 7-10: start of measuring range, value for 4 mA - Byte 11-14: attenuation constant in [s] - Byte 15: ID for write protection - Byte 16: OEM retailer ID, 17 = E+H <i>Factory setting:</i> Primary process variable = volume flow channel 1  Note! <ul style="list-style-type: none"> ■ The assignment of the device variables to the process variable can be specified via command 51. ■ Manufacturer-specific units are represented using the HART unit ID "240".

Command No. HART command / access type		Command data (numeric data in decimal form)	Response data (numeric data in decimal form)
16	Read the device production number Access type = Read	None	Byte 0-2: production number
17	Write user message Access = Write	You can save any 32-character text in the device with this parameter: Byte 0-23: desired user message	Displays the current user message in the device: Byte 0-23: current user message in the device
18	Write TAG, TAG description and date Access = Write	You can save an 8-character TAG, a 16-character TAG description and a date with this parameter: – Byte 0-5: TAG – Byte 6-17: TAG description – Byte 18-20: date	Displays the current information in the device: – Byte 0-5: TAG – Byte 6-17: TAG description – Byte 18-20: date

The following table contains all the common practice commands supported by the device.

Command No. HART command / access type	Command data (numeric data in decimal form)	Response data (numeric data in decimal form)
Common practice commands		
34	Write attenuation constant for the primary process variable Access = Write	Byte 0-3: attenuation constant of the primary process variable in seconds <i>Factory setting:</i> Primary process variable = volume flow channel 1
35	Write measuring range of the primary process variable Access = Write	Write the desired measuring range: – Byte 0: HART unit ID for the primary process variable – Byte 1-4: end of measuring range, value for 20 mA – Byte 5-8: start of measuring range, value for 4 mA <i>Factory setting:</i> Primary process variable = volume flow channel 1  Note! ■ The assignment of the device variables to the process variable can be specified via command 51. ■ If the HART unit ID does not suit the process variable, the device will continue with the last valid unit.
38	Reset the device status "configuration changed" Access = Write	None
40	Simulate the output current of the primary process variable Access = Write	Simulation of the desired output current of the primary process variable. If a value of 0 is entered, the device exits the simulation mode: Byte 0-3: output current in mA <i>Factory setting:</i> Primary process variable = volume flow channel 1  Note! The assignment of the device variables to the process variable can be specified via command 51.
42	Perform device reset Access = Write	None
44	Write unit of the primary process variable Access = Write	Specify the unit of the primary process variable. Only units which are suitable for the process variable are accepted by the device: Byte 0: HART unit ID <i>Factory setting:</i> Primary process variable = volume flow channel 1  Note! ■ If the HART unit ID written does not suit the process variable, the device will continue with the last valid unit. ■ If the unit of the primary process variable is changed, this does not affect the system units.
		Displays the current attenuation constant in the device: Byte 0-3: attenuation constant in seconds
		The measuring range currently set is shown as the response: – Byte 0: HART unit ID for the set measuring range of the primary process variable – Byte 1-4: end of measuring range, value for 20 mA – Byte 5-8: start of measuring range, value for 4 mA  Note! Manufacturer-specific units are represented using the HART unit ID "240".
		None
		The current output current of the primary process variable is displayed as the response: Byte 0-3: output current in mA
		None
		The current unit code of the primary process variable is displayed as the response: Byte 0: HART unit ID  Note! Manufacturer-specific units are represented using the HART unit ID "240".

Command No. HART command / access type		Command data (numeric data in decimal form)	Response data (numeric data in decimal form)
48	Read extended device status Access = Read	None	The current device status is displayed in extended form as the response: Coding: see table → 80
50	Read assignment of the device variables to the four process variables Access = Read	None	The current variable assignment of the process variables is displayed: <ul style="list-style-type: none"> – Byte 0: device variable ID for the primary process variable – Byte 1: device variable ID for the secondary process variable – Byte 2: device variable ID for the third process variable – Byte 3: device variable ID for the fourth process variable <i>Factory setting:</i> <ul style="list-style-type: none"> ■ Primary process variable: ID 30 for volume flow, channel 1 ■ Secondary process variable: ID 250 for totalizer 1 ■ Third process variable: ID 40 for sound velocity, channel 1 ■ Fourth process variable: ID 49 for flow velocity, channel 1 Note! The assignment of the device variables to the process variable can be specified via command 51.
51	Write assignments of the device variables to the four process variables Access = Write	Specify the device variables for the four process variables: <ul style="list-style-type: none"> – Byte 0: device variable ID for the primary process variable – Byte 1: device variable ID for the secondary process variable – Byte 2: device variable ID for the third process variable – Byte 3: device variable ID for the fourth process variable <i>ID of the supported device variables:</i> See information → 106 <i>Factory setting:</i> <ul style="list-style-type: none"> ■ Primary process variable = volume flow channel 1 ■ Secondary process variable = totalizer 1 ■ Third process variable = sound vel. channel 1 ■ Fourth process variable = flow vel. channel 1 	The current variable assignment of the process variables is displayed as the response: <ul style="list-style-type: none"> – Byte 0: device variable ID for the primary process variable – Byte 1: device variable ID for the secondary process variable – Byte 2: device variable ID for the third process variable – Byte 3: device variable ID for the fourth process variable
53	Write unit of the device variable Access = Write	This command specifies the unit of the given device variables. Only those units which suit the device variable are accepted: <ul style="list-style-type: none"> – Byte 0: device variable ID – Byte 1: HART unit ID <i>ID of the supported device variables:</i> See information → 106 Note! <ul style="list-style-type: none"> ■ If the written unit does not suit the device variable, the device will continue with the last valid unit. ■ If the unit of the device variable is changed, this does not affect the system units. 	The current unit of the device variables is displayed in the device as the response: <ul style="list-style-type: none"> – Byte 0: device variable ID – Byte 1: HART unit ID Note! Manufacturer-specific units are represented using the HART unit ID "240".
59	Specify the number of preambles in message responses Access = Write	This parameter specifies the number of preambles which are inserted in the message responses: Byte 0: number of preambles (2 to 20)	The current number of preambles is displayed in the response message as the response: Byte 0: number of preambles

5.5.5 Device status/error messages

You can read the extended device status (in this case, current error messages) via command "48". The command delivers bit-encoded information (see table below).



Note!

Detailed information on the device status messages and error messages, and how they are rectified, can be found in the system error messages section → [106](#).

Byte	Bit	Error no.	Short error description → 105
0	0	001	Critical Device Error
	1	011	Faulty amplifier EEPROM.
	2	012	Error when accessing data of the amplifier EEPROM.
	3	041	T-DAT: defective or missing
	4	042	T-DAT: error when accessing saved values
	5	082	Connection (downstream) between sensor CH1 and Transmitter interrupted
	6	083	Connection (downstream) between sensor CH2 and Transmitter interrupted
	7	085	Connection (upstream) between sensor CH1 and Transmitter interrupted
1	0	086	Connection (upstream) between sensor CH2 and Transmitter interrupted
	1 to 2	Not assigned	–
	3	111	Totalizer checksum error
	4	205	T-Dat : Data upload failed
	5	206	T-Dat : Data download failed
	6	251	Communication error on the amplifier board
	7	261	No data reception between amplifier and I/O board
2	0	Not assigned	–
	1	355	Frequency Output: the actual flow is out range
	2	356	
	3	357	
	4	358	
	5	359	Pulse Output: the pulse output frequency is outside the permitted range
	6	360	
7	361		
3	0	362	–
	1 – 5	Not assigned	–
	6	392	I/O board and amplifier board are not compatible.
	7	393	Attenuation of the acoustic measurement too high (Channel 2)
4	2	Not assigned	–
	3	592	Channel 1: initializing. All outputs set to "0"
	4	593	Channel 2: initializing. All outputs set to "0"
	5	602	Positive zero return active (CH1)
	6	603	Positive zero return active (CH2)
	7	604	Positive zero return active (CH1 + CH2)
5	0	621	Frequency Output simulation active
	1	622	
	2	623	
	3	624	
	4	631	Pulse Output simulation active
	5	632	
	6	633	
	7	634	

Byte	Bit	Error no.	Short error description →  105
6	0 – 7	Not assigned	–
7	0 – 7	Not assigned	–
8	0 – 7	Not assigned	–
9	0 to 7	Not assigned	–
10	0	351	Current Output: the actual flow is out of range
	1	352	
	2	353	
	3	354	
	4 – 7	Not assigned	–
11	0 to 7	Not assigned	–
12	0 to 7	Not assigned	–
13	0	611	Pulse Output simulation active
	1	612	
	2	613	
	3	614	
	4 – 7	Not assigned	–
14	0	641	Status output simulation active
	1	642	
	2	643	
	3	644	
	4	651	Relay output simulation active
	5	652	
	6	653	
	7	654	
15	0	661	Current input simulation active
	1	662	
	2	663	
	3	664	
	4	671	Status input simulation active
	5	672	
	6	673	
	7	674	
16	0	691	Simulation of failsafe mode (outputs) active
	1	694	Channel 1: simulation of volume flow active
	2	695	Channel 2: simulation of volume flow active
	3 – 6	Not assigned	–
	7	740	Channel 1: static zero point adjustment active
17	0	741	Channel 2: static zero point adjustment active
	1	742	Channel 1+2: static zero point adjustment active
	2	743	Channel 1: static zero point adjustment is not possible
	3	744	Channel 2: static zero point adjustment is not possible
	4	745	Channels 1+ 2: static zero point adjustment is not possible
	5	752	Channel 1: Wall thickness measurement active
	6	753	Channel 2: Wall thickness measurement active
	7	754	Channel 1: Wall thickness calibration active

Byte	Bit	Error no.	Short error description →  105
18	0	755	Channel 2: Wall thickness calibration active
	1	757	Channel 1: Wall thickness calibration failed
	2	758	Channel 2: Wall thickness calibration failed
	3	339	Current Buffer: The buffering of the flow components (measuring mode with pulsating flow) could not be calculated within 60 seconds
	4	340	
	5	341	
	6	342	
	19	7	343
0		344	
1		345	
2		346	Pulse Buffer: The buffering of the flow components (measuring mode with pulsating flow) could not be calculated within 60 seconds
3		347	
4		348	
5		349	
6		350	L/O Board and amplifier board are only partially compatible
7	121		
20	0	061	Advanced diagnostic messages
	1	810	
	2	811	
	3	812	
	4	813	
	5	814	
	6	815	
	7	820	
21	0	821	Advanced diagnostic messages
	1	822	
	2	823	
	3	824	
	4	825	
	5	830	
	6	831	
	7	833	
22	0 to 5	Not assigned	–
	6	363	Actual current input is out of range
	7	Not assigned	–
23	0 – 1	Not assigned	–
	2	698	The Measuring Device is being checked on site via the test and simulation device
	3 – 7	Not assigned	–

6 Commissioning

6.1 Function check

Make sure that all final checks have been completed before you commission your measuring point:

- Checklist for "Post-installation check" →  57
- Checklist for "Post-connection check" →  65

Switching on the measuring device

If you have completed the post-connection checks (→  65), switch on the supply voltage. The device is operational!

The measuring system performs a number of internal test functions after power-up. During this process, the following sequence of messages appears on the local display:

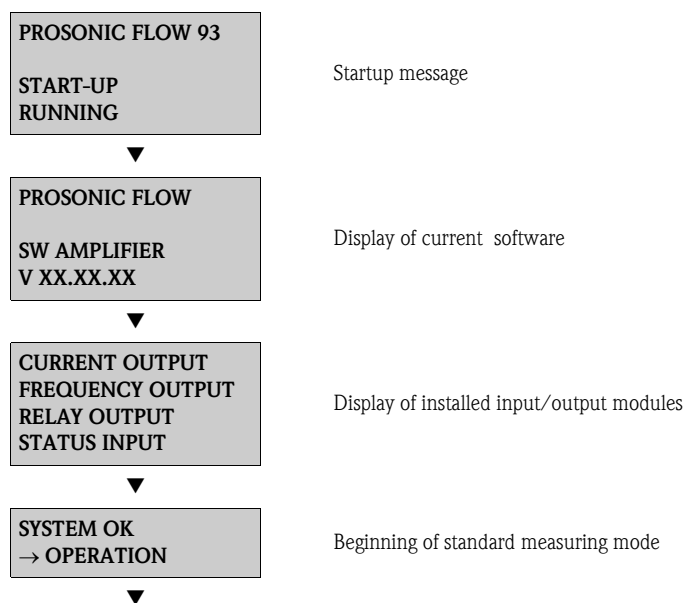

Normal measuring mode commences as soon as startup completes.

Various measured value and/or status variables appear on the display (HOME position).



Note!

If startup fails, an appropriate error message is displayed, depending on the cause.

6.2 Commissioning via onsite display

6.2.1 Quick Setup "Sensor Installation"

The installation distances needed to install the sensors can be determined using the "Sensor Installation" Quick Setup menu → 17.

In the case of measuring devices without a local display, the installation distances can be determined via the FieldCare operating program → 22 or with the Applicator online tool → 28.

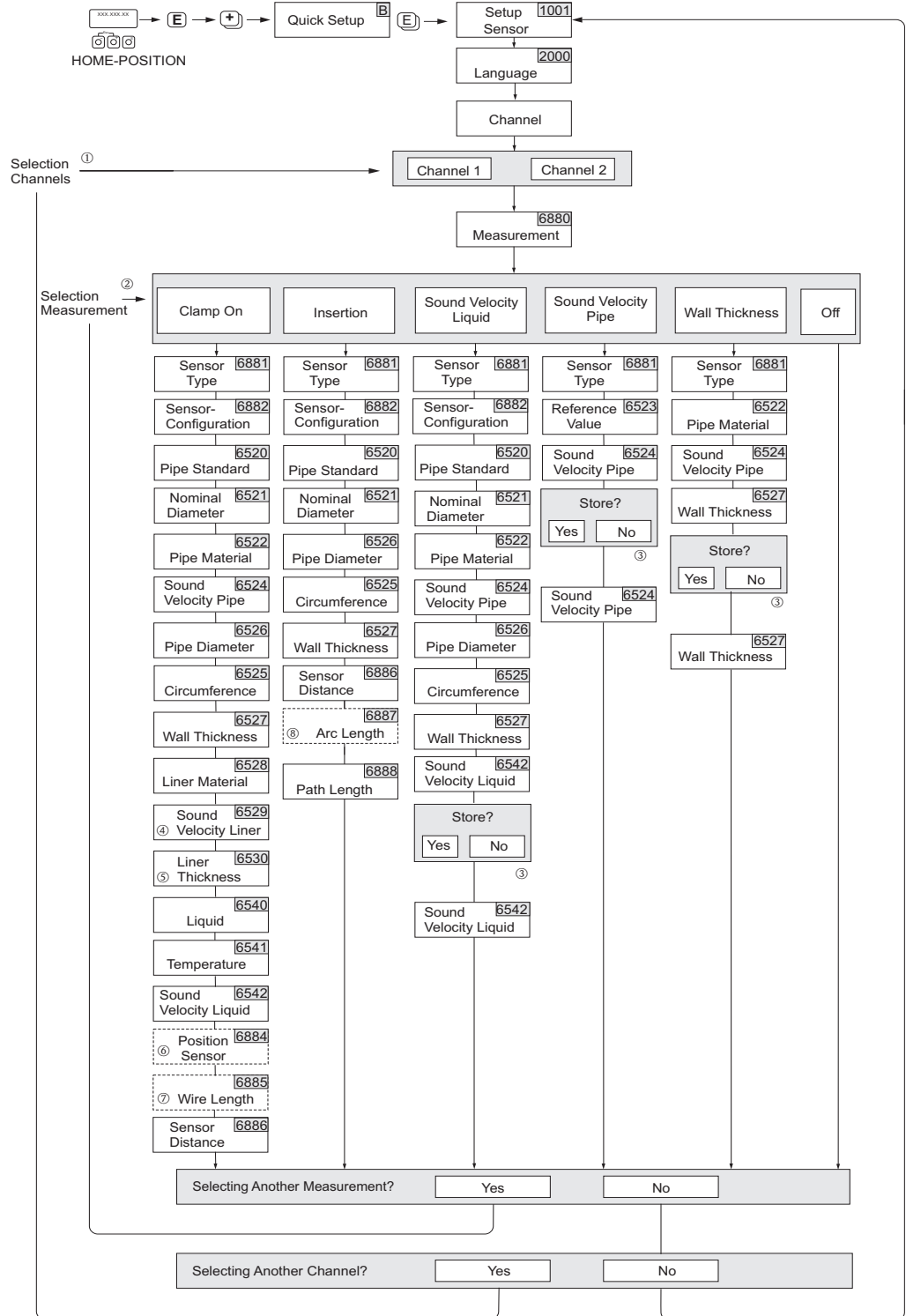

Fig. 78: Quick Setup menu "Sensor" (only via onsite display)

**Note!**

The display returns to the function SETUP SENSOR (1001) if you press the ESC key combination during parameter interrogation.

- ① If a channel is selected for which a Quick Setup has already been executed, the previous values are overwritten.
- ② During each run, all the options can be selected. If settings were made during a previous run, these are overwritten.
- ③ "Save?" prompt for pipe sound velocity:
 - YES = The value measured during Quick Setup is accepted in the appropriate function.
 - NO = The measurement is discarded and the original value remains.
- ④ The SOUND VELOCITY LINER (6529) only appears if:
 - The LINER MATERIAL is selected to something other than NONE (6528).
- ⑤ The LINER THICKNESS (6530) only appears if:
 - The LINER MATERIAL is selected to something other than NONE (6528).
- ⑥ The POSITION SENSOR function (6884) only appears if:
 - The clamp-on option is selected in the MEASUREMENT function (6880)
 - and**
 - Two traverses are selected in the SENSOR CONFIGURATION function (6882)
- ⑦ The WIRE LENGTH function (6885) only appears if:
 - The clamp-on option is selected in the MEASUREMENT function (6880)
 - and**
 - One traverse is selected in the SENSOR CONFIGURATION function (6882)
- ⑧ The ARC LENGTH function (6887) only appears if:
 - The INSERTION option is selected in the MEASUREMENT function (6880)
 - and**
 - The DUAL-PATH option is selected in the SENSOR CONFIGURATION function (6882)

6.2.2 Quick Setup "Commissioning"

In the case of measuring devices without a local display, the individual parameters and functions must be configured via the operating program, e.g. FieldCare.

If the measuring device is equipped with a local display, all the important device parameters for standard operation, as well as additional functions, can be configured quickly and easily by means of the following Quick Setup menus.

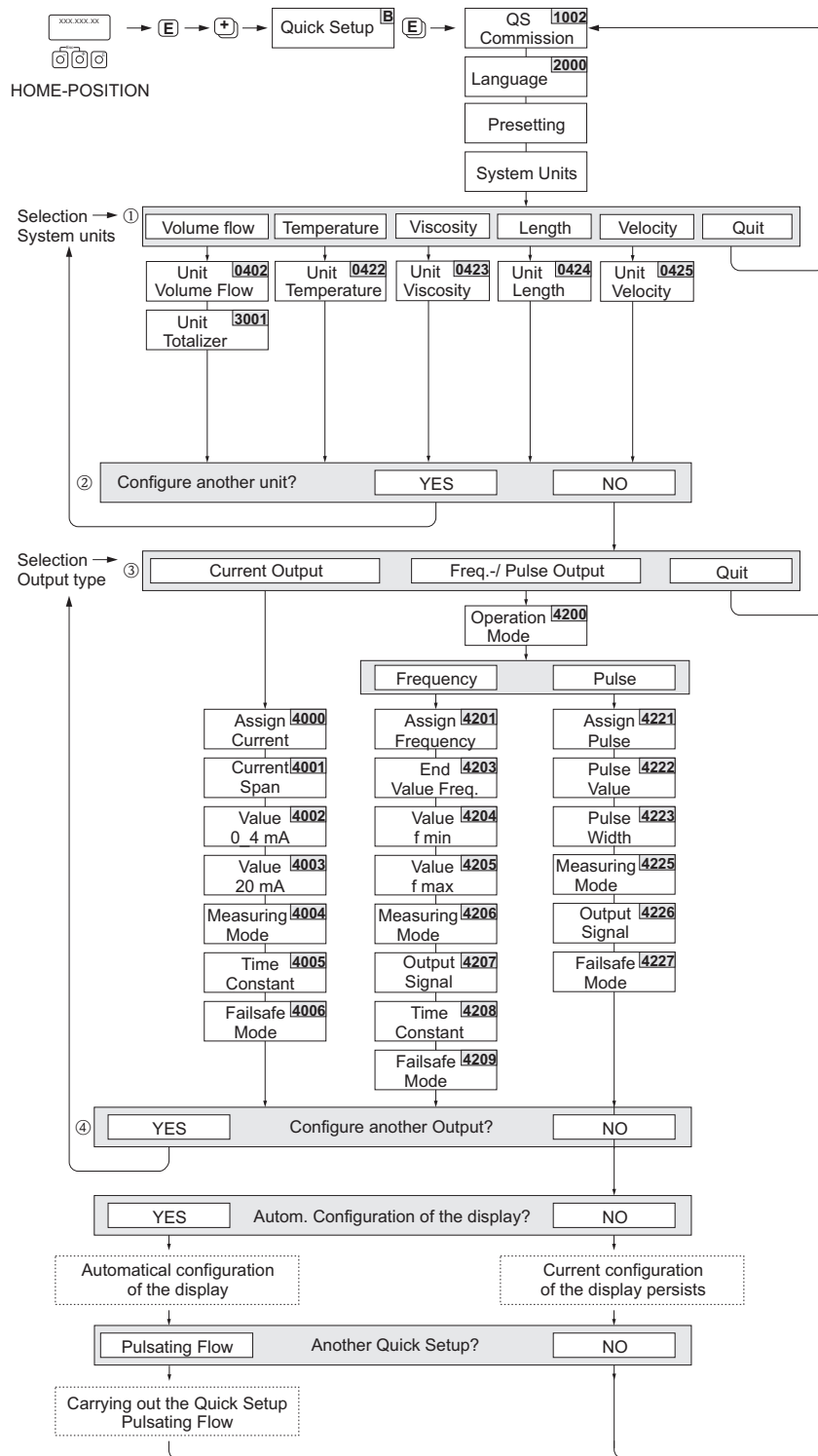

A0009881-en

Fig. 79: Quick Setup "Commissioning"



Note!

- The display returns to the function SETUP COMMISSIONING (1002) if you press the ESC key combination during parameter interrogation.
- If you answer YES to the question regarding the "Automatic configuration of the display", the display lines are assigned as follows:
 - Main line = volume flow

- Additional line = totalizer 1
 - Information line = operating/system condition
-
- ① Only units not yet configured in the current Quick Setup are offered for selection in each cycle. The volume unit is derived from the volume flow unit.
 - ② The "YES" option remains visible until all the units have been configured.
"NO" is the only option displayed when no further units are available.
 - ③ Only outputs not yet configured in the current Quick Setup are offered for selection in each cycle.
 - ④ The "YES" option appears as long as a free output is still available.
"NO" is the only option displayed when no further outputs are available.

6.2.3 Quick Setup "Pulsating Flow"

A flow that fluctuates severely, for a temporary period, occurs when using pump types that transport media in a pulsating manner, such as reciprocating pumps, peristaltic pumps and eccentric pumps. Negative flow on account of the closing volume or valve leakage can also occur with these pumps.



Note!

Execute the Quick Setup "Commissioning" before running the Quick Setup "Pulsating Flow"

→ 85.

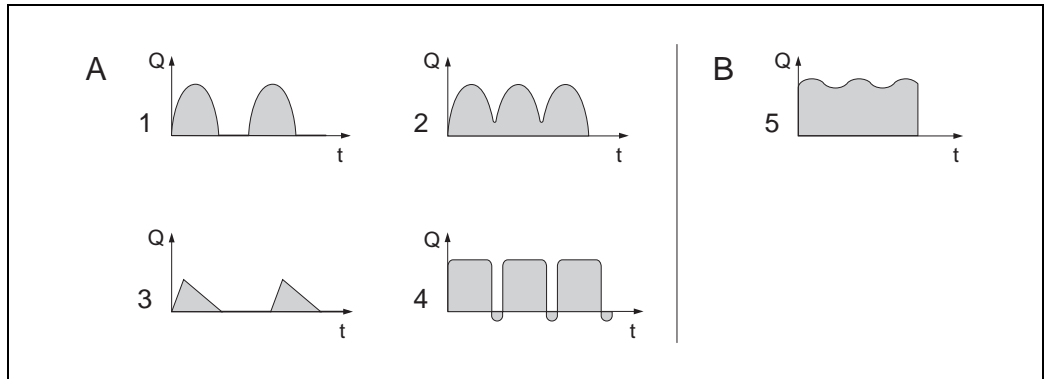

Fig. 80: Flow characteristic of different pump types

A With high pulsating flow

B With low pulsating flow

1 1-cylinder eccentric pump

2 2-cylinder eccentric pump

3 Solenoid pump

4 Peristaltic pump, flexible connecting cable

5 Multi-cylinder reciprocating pump

High pulsating flows

By specifically configuring a number of different device functions via the "Pulsating Flow" Quick Setup, flow fluctuations over the entire flow range can be compensated for, and pulsating liquid flows can be measured correctly. The process for executing the Quick Setup menu is described in detail in the next section.



Note!

It is recommended to always run the "Pulsating Flow" Quick Setup if you are unsure of the exact flow characteristics.

Low pulsating flows

It is **not** absolutely essential to run the Quick Setup if only minor flow fluctuations occur, e.g. when using gear-type pumps, three-cylinder or multi-cylinder pumps.

In such situations, however, it is advisable to adapt the functions listed below (see "Description of Device Functions" manual) to meet the local process conditions to achieve a stable, constant output signal. This applies, in particular, to the current output:

- Measuring system damping: "SYSTEM DAMPING" function → Increase value
- Current output damping: "TIME CONSTANT" function → Increase value

Running the "Pulsating Flow" Quick Setup

With the aid of this Quick Setup, the user is systematically guided through all the device functions that have to be adjusted and configured for measuring operation with pulsating flow. Values that are already configured, such as the measuring range, current range or full scale value, are not changed in the process!

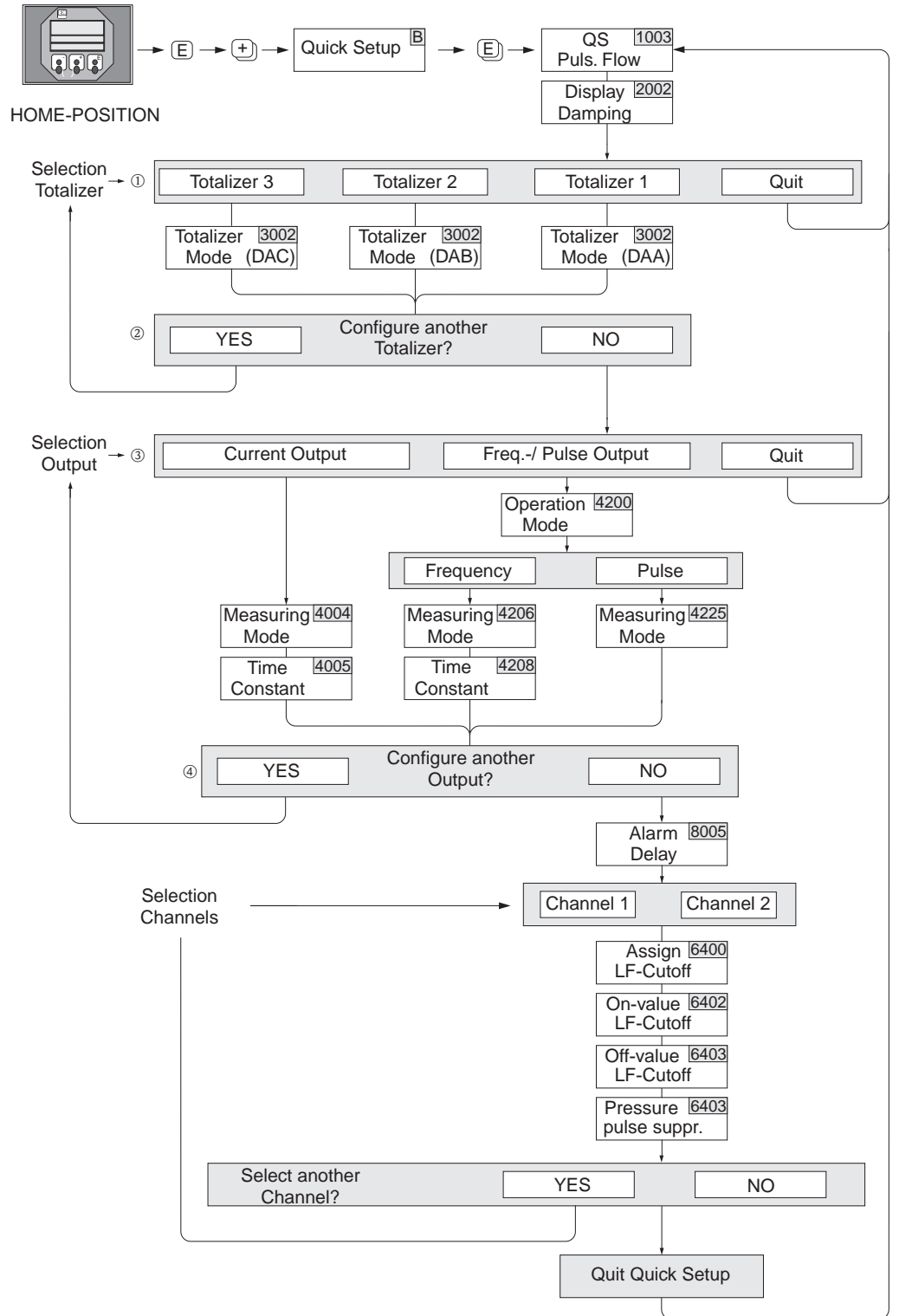

Fig. 81: "Quick Setup" menu for operation with high pulsating flow



Note!

- The display returns to the function SETUP PULSATING FLOW (1003) if you press the ESC key combination during parameter interrogation.
- This Quick Setup can either be called up directly after the "COMMISSIONING" Quick Setup, or it can be called up manually via the SETUP PULSATING FLOW function (1003).

- ① Only counters not yet configured in the current Quick Setup are offered for selection in each cycle.
- ② The "YES" option remains visible until all the counters have been configured.
"NO" is the only option displayed when no further counters are available.
- ③ Only outputs not yet configured in the current Quick Setup are offered for selection in each cycle.
- ④ The "YES" option remains visible until all the outputs have been configured.
"NO" is the only option displayed when no further outputs are available.

Quick Setup "Pulsating Flow"		
HOME position → <input type="checkbox"/> → MEASURED VARIABLE (A) MEASURED VARIABLE → <input type="checkbox"/> → QUICK SETUP (B) QUICK SETUP → N → QS PULS. FLOW (1003)		
Function No.	Function name	Setting to be selected (P)
1003	QS PULS. FLOW.	Yes
After <input type="checkbox"/> is pressed by way of confirmation, the Quick Setup menu calls up all the subsequent functions in succession.		

Basic settings		
2002	DISPLAY DAMPING	1 s
3002	TOTALIZER MODE (DAA)	BALANCE (totalizer 1)
3002	TOTALIZER MODE (DAB)	BALANCE (totalizer 2)
3002	TOTALIZER MODE (DAC)	BALANCE (totalizer 3)
Type of signal for "CURRENT OUTPUT 1 to n"		
4004	MEASURING MODE	PULS. FLOW
4005	TIME CONSTANT	1 s
Type of signal for "FREQ./PULSE OUTPUT 1 to n" (for FREQUENCY operating mode)		
4206	MEASURING MODE	PULS. FLOW
4208	TIME CONSTANT	0 s
Type of signal for "FREQ./PULSE OUTPUT 1 to n" (for PULSE operating mode)		
4225	MEASURING MODE	PULS. FLOW
Other settings		
8005	ALARM DELAY	0 s
6400	ASSIGN LF CUT OFF	VOLUME FLOW
6402	ON-VAL. LF CUT OFF	Recommended setting 0.4 l/s
6403	OFF-VAL. LF CUT OFF	50%
6404	PRESS. SHOCK SUPP.	0 s

<p>Back to the HOME position</p> <p>→ Press and hold down Esc key (<input type="checkbox"/>) for longer than three seconds.</p> <p>→ Repeatedly press and release Esc key (<input type="checkbox"/>) → Exit the function matrix step by step</p>

6.3 Application-specific commissioning

6.3.1 Zero point adjustment

Zero point adjustment is generally not necessary!

Experience shows that the zero point adjustment is advisable only in special cases:

- To achieve highest measuring accuracy with very low flow rates.
- Under extreme process or operating conditions (e.g. very high process temperatures or very high viscosity fluids).

Preconditions for a zero point adjustment

Note the following before you perform a zero point adjustment:

- A zero point adjustment can be performed only with fluids that have no gas or solid contents.
- Zero point adjustment is performed with the measuring tube completely filled and at zero flow ($v=0$ m/s). This can be achieved, for example, with shutoff valves upstream and/or downstream of the measuring range or by using existing valves and gates (→ 91).
 - Standard operation → Valves 1 and 2 open
 - Zero point adjustment with pump pressure → Valve 1 open / valve 2 closed
 - Zero point adjustment without pump pressure → Valve 1 closed / valve 2 open.



Caution!

- If the fluid is very difficult to measure (e.g. containing entrained solids or gas) it may prove impossible to obtain a stable zero point despite repeated zero point adjustments. In instances of this nature, please contact your Endress+Hauser service center.
- You can view the currently valid zero point value using the ZERO POINT function (→ "Description of Device Functions" manual).

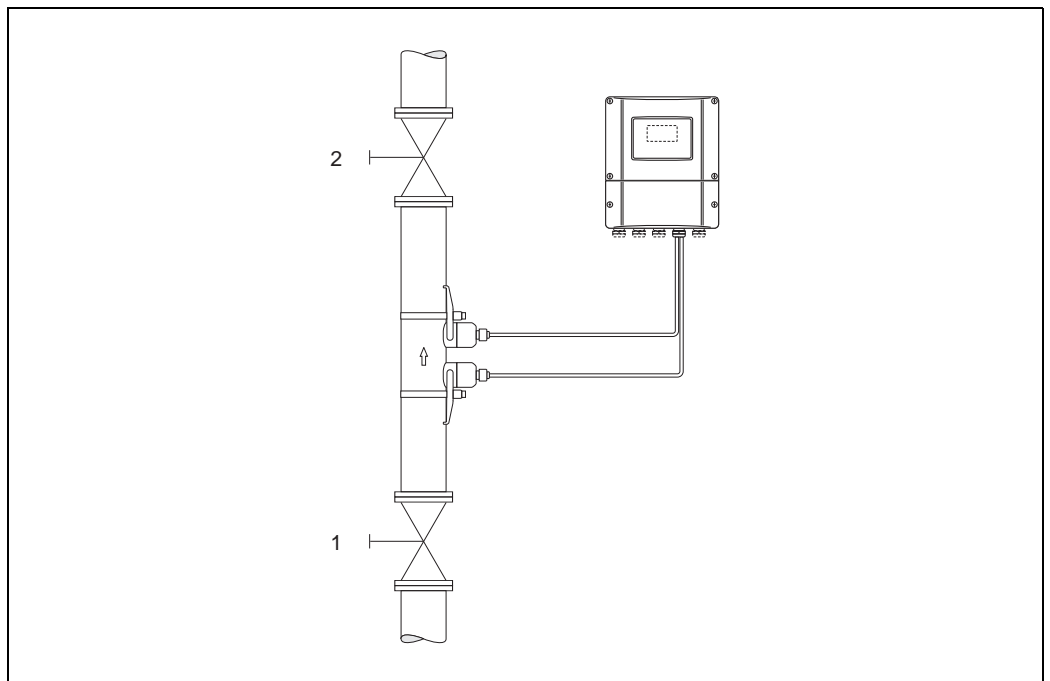

Fig. 82: Zero point adjustment and shutoff valves

A0001143

Performing a zero point adjustment

1. Operate the system until normal operating conditions resume.
2. Stop the flow ($v = 0$ m/s).
3. Check the shutoff valves for leaks.
4. Check that operating pressure is correct.
5. Using the local display, select the "ZEROPOINT ADJUST" function in the function matrix:

HOME → → R → BASIC FUNCTIONS
 BASIC FUNCTIONS → → R → PROCESS PARAMETER CH1/CH2
 PROCESS PARAMETER → → R → ADJUSTMENT
 ADJUSTMENT → → ZEROPOINT ADJUST
6. When you press you are automatically prompted to enter the access code if the function matrix is still disabled. Enter the code.
7. With , select the START setting and confirm with .
 Acknowledge the security prompt with YES and press to confirm. Zero point adjustment is now started:
 - The message "ZEROPOINT ADJUST RUNNING" appears on the display for 30 to 60 seconds while adjustment is in progress.
 - If the flow in the pipe exceeds 0.1 m/s (0.33 ft/s), the following error message appears on the display: ZERO ADJUST NOT POSSIBLE.
 - When the zero point adjustment completes, the "ZERO ADJUST" function reappears on the display.
8. Back to the HOME position
 - Press and hold down Esc key () for longer than three seconds.
 - Repeatedly press and release the Esc key ()

6.3.2 Advanced diagnostic functions

Changes to the measuring system can be detected at an early stage with the optional "Advanced diagnostics" software package (F-CHIP, accessories, →  99). Such influencing factors normally reduce the system accuracy or result in system errors in extreme situations. With the diagnostic functions, it is possible to record various process and device parameters during measuring operation, such as volume flow, flow velocity, signal strength, sound velocity, etc. By analyzing the trend of these measured values, deviations on the part of the measuring system from a "reference state" can be detected at an early stage and countermeasures can be taken.

Reference values as the basis for trend analysis

For trend analysis, reference values of the parameters in question always have to be recorded. These reference values are determined under reproducible, constant conditions. Reference data are acquired under customer-specific process conditions, e.g. during commissioning or certain processes (cleaning cycles, etc.).

Reference values are recorded and saved in the measuring system via the device function → REFERENCE CONDITION USER (7601).



Caution!

It is not possible to analyze the trend of process/device parameters without reference values! Reference values can only be determined under constant, unchanging process conditions.

Data acquisition method

There are two different ways of recording process and device parameters. You can specify the method you would like to use in the function → ACQUISITION MODE (7610):

- "PERIODICAL" option: data are acquired periodically by the device. The desired interval is entered via the "ACQUISITION PERIOD (7611)" function.
- "SINGLE SHOT" option: data are acquired manually by the user at times defined by the user.

Make sure you acquire data when the process conditions correspond to the reference state. This is the only way deviations from the reference state can be determined reliably and clearly.



Note!

The last ten entries are stored in the measuring system.

The "history" of these values can be called up via various functions:

Diagnostic parameter	Data records saved (per parameter)
Volume flow Flow velocity Signal strength Sound velocity Transit time Acceptance rate	– Reference value → "REFERENCE VALUE" function – Lowest measured value → "MINIMUM" function – Highest measured value → "MAXIMUM" function – List of the last ten measured values → "HISTORY" function – Measured value/reference value deviation → "DEVIATION" function
 Note!	More detailed information on this is provided in the "Description of Device Functions" manual.

Triggering warnings

Where necessary, a limit value can be assigned to the process/device parameters that are relevant to diagnosis whereby a warning message is triggered if this limit value is exceeded → "WARNING MODE (7603)" function.

The limit value is entered in the measuring system as a relative deviation from the reference value → "WARNING LEVEL (76...)" function.

Deviations can be output via the current or relay outputs.

Interpreting data

The interpretation of the data records recorded by the measuring system depends greatly on the actual application. This means that the user has to have a good knowledge of the process conditions and the associated deviations in the process, which have to be determined by the user in each individual case.

For example, knowledge of the permitted maximum and minimum deviations is particularly important to be able to use the limit value function. Otherwise there is the risk that a warning message is unintentionally triggered when "normal" fluctuations in the process occur.

There can be several reasons why the system deviates from the reference state. The table below lists a number of examples and possible causes:

Diagnostic parameter	Possible causes behind deviations from the reference value
Signal strength	A change in the signal strength can be put down to changes in the process, e.g. higher level of gas or solids in the liquid, or less than optimum signal processing as the coupling fluid has dried out or has been rinsed out.
Sound velocity	A change in the sound velocity can be put down to altered process conditions. The most common reasons are changes in the temperature or makeup of the liquid. Optimum measurement takes place when the change in sound velocity is smaller than $\pm 10\%$.
Measured transit time Time the signal takes to travel from the transmitter to the sensor, pipe, liquid, pipe, sensor and back to the transmitter. The transit time in the liquid is relevant for the flow velocity.	The transit time measured is proportional to the sound velocity and behaves like it.
Acceptance rate The acceptance rate indicates the number of measurements that are used for calculating the flow.	A drop in the acceptance rate is caused by fluctuating signal strength and is an indicator of gas pockets or solids in the liquid.

6.3.3 Data storage with "T-DAT SAVE/LOAD"

Using the "T-DAT SAVE/LOAD" function, it is possible to save all the settings and parameters of the device to the T-DAT data storage device.

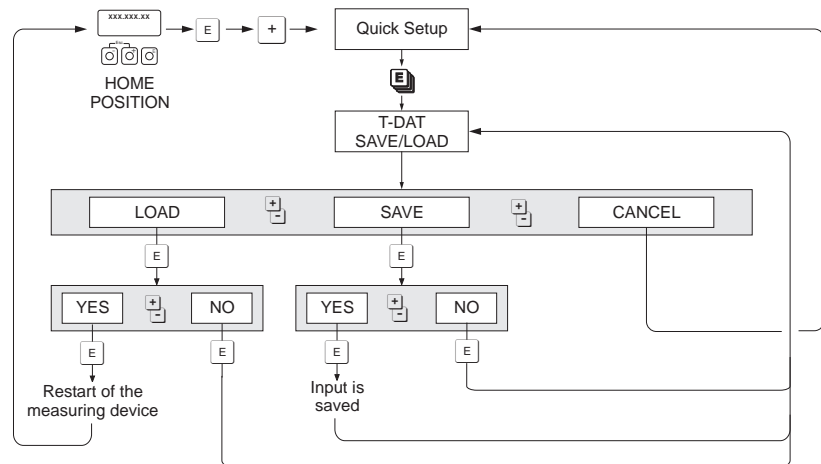

A0001221-en

Fig. 83: Data storage with the "T-DAT SAVE/LOAD" function

Options

LOAD

Data on the T-DAT data storage device are copied to the device memory (EEPROM). This overwrites all the previous settings and parameters of the device. The device is restarted.

SAVE

Settings and parameters are copied from the device memory (EEPROM) to the T-DAT.

CANCEL

The procedure is aborted and the system returns to the higher selection level.

Application examples

- The current measuring point parameters can be saved to the T-DAT (backup) after commissioning.
- When replacing the transmitter, it is possible to load the data from the T-DAT to the new transmitter (EEPROM).



Note!

- If the software of the target device is older, the message "TRANSM. SW-DAT" is displayed during startup. Only the "SAVE" function is available then.
- **LOAD**
This function is only possible if the software version of the target device is the same as, or more recent than, that of the source device.
- **SAVE**
This function is always available.

6.4 Hardware settings

6.4.1 Switching HART write protection on/off

A jumper on the I/O board provides the means of activating or deactivating HART write protection.



Warning!

Risk of electric shock. Exposed components carry dangerous voltages. Make sure that the power supply is switched off before you remove the cover of the electronics compartment.

1. Switch off power supply.
2. Remove the I/O board. → 114
3. Switch HART write protection on or off with the jumper.
4. Install the I/O board → 114.

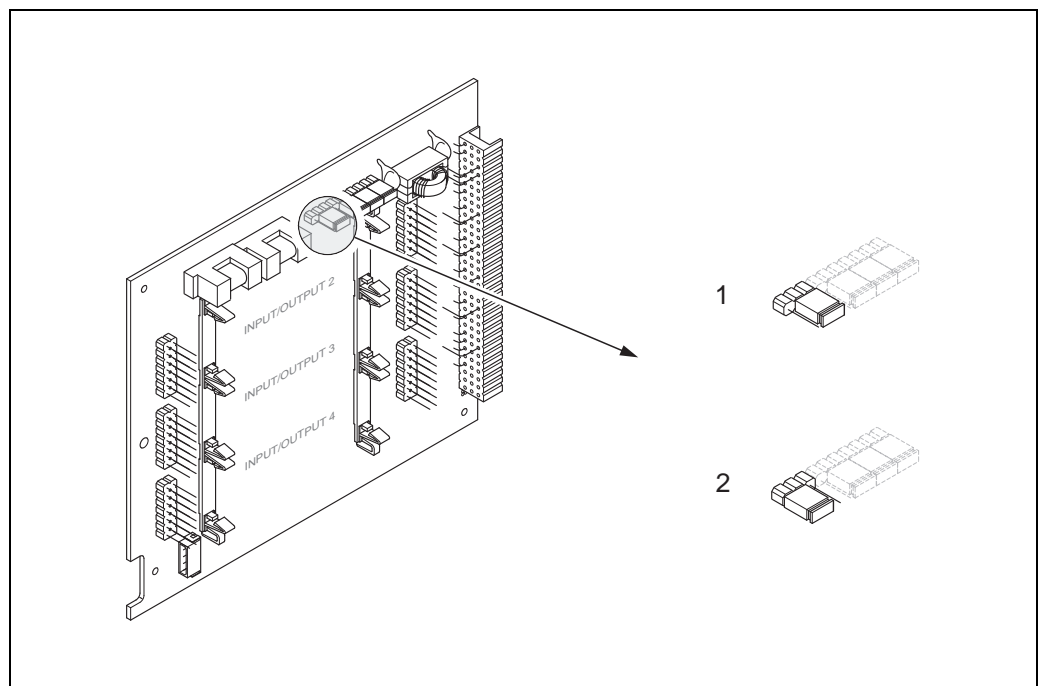

Fig. 84: Switching HART write protection on/off (I/O board)

- 1 Write protection switched off (factory setting), i.e. HART protocol enabled
- 2 Write protection switched on (factory setting), i.e. HART protocol disabled

6.4.2 Current output: active/passive

The current outputs can be configured as "active" or "passive" outputs via various jumpers on the I/O board or the current submodule.



Warning!

Risk of electric shock. Exposed components carry dangerous voltages. Make sure that the power supply is switched off before you remove the cover of the electronics compartment.

1. Switch off power supply.
2. Remove the I/O board. → [114](#)
3. Position the jumpers as per → [97](#).



Caution!

– Risk of destroying measuring devices!

Observe the exact positions of the jumpers. If jumpers are incorrectly connected, this can result in excess current and the destruction of the device itself, or devices connected externally!

– Please note that the position of the current submodule on the I/O board can differ depending on the order version. Consequently the terminal assignment in the connection compartment of the transmitter can also differ → [62](#).

4. Install the I/O board → [114](#).

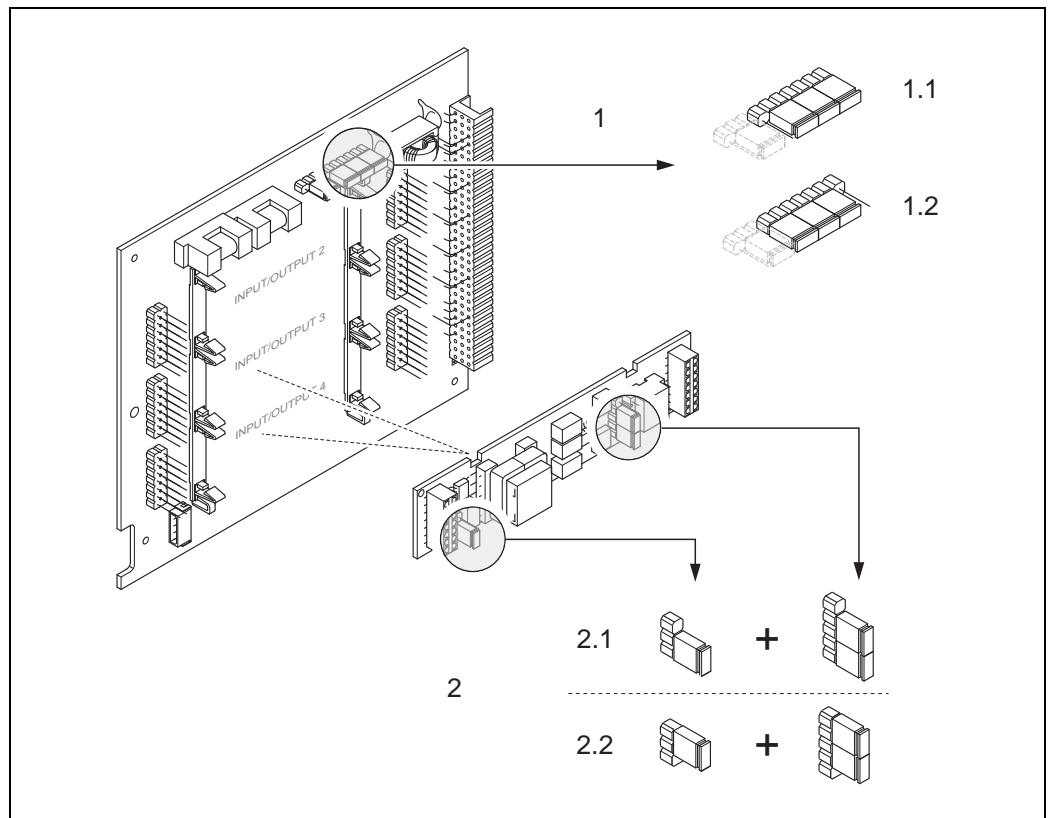

Fig. 85: Configuring the current output with the jumpers (I/O board)

- 1 Current output 1 with HART
- 1.1 Active (factory setting)
- 1.2 Passive
- 2 Current output 2 (optional, plug-in module)
- 2.1 Active (factory setting)
- 2.2 Passive

6.4.3 Relay contacts: NC contact/NO contact

The relay contact can be configured as an "NC contact" or "NO contact" via two jumpers on the I/O board or the relay submodule. The current configuration is displayed in the "ACTUAL STATUS RELAY" function (4740).



Warning!

Risk of electric shock. Exposed components carry dangerous voltages. Make sure that the power supply is switched off before you remove the cover of the electronics compartment.

1. Switch off power supply.
2. Remove the I/O board. → [114](#)
3. Position the jumpers appropriately.



Caution!

- The configuration of the jumpers on the permanent-assignment board is the inverse of the configuration on the flexible-assignment board. Observe the illustration in the graphics.
- If reconfiguring, the two jumpers have to be unplugged and plugged into the opposite slot!
- Please note that the position of the relay submodule on the flexible-assignment I/O board can differ depending on the order version. Consequently the terminal assignment in the connection compartment of the transmitter can also differ → [62](#).

4. Install the I/O board → [114](#).

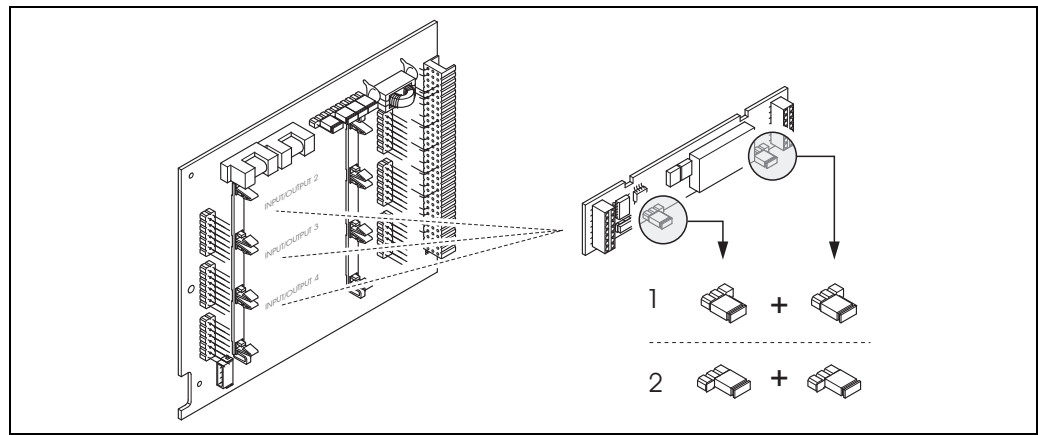

Fig. 86: Configuring the relay contacts (NC contact / NO contact) for the flexible-assignment I/O board

- 1 NO contact shown in detail (relay 1 factory setting)
- 2 NC contact shown in detail (relay 2 factory setting, if available)

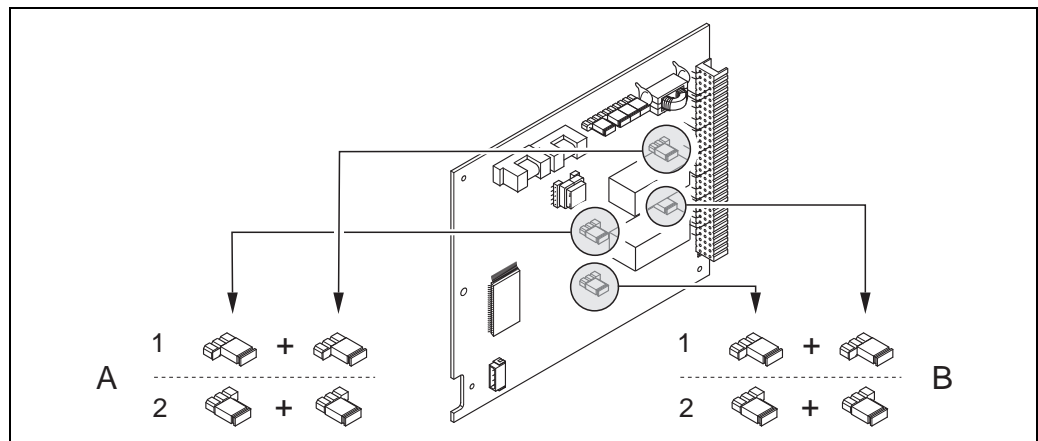

Fig. 87: Configuring the relay contacts (NC contact / NO contact) for the permanent-assignment I/O board

- 1 NO contact shown in detail (relay 1 factory setting)
- 2 NC contact shown in detail (relay 2 factory setting)

6.5 Data storage device (HistoROM, F-CHIP)

At Endress+Hauser, the term HistoROM refers to various types of data storage modules on which process and measuring device data are stored. By plugging and unplugging such modules, device configurations can be duplicated onto other measuring devices to cite just one example.

6.5.1 HistoROM/T-DAT (transmitter-DAT)

The T-DAT is an exchangeable data storage device in which all transmitter parameters and settings are stored.

Storing of specific parameter settings from the EEPROM to the T-DAT and vice versa has to be carried out by the user (= manual save function). Please refer to →  95 for a description of the related function (T-DAT SAVE/LOAD) and the exact procedure for managing data.

6.5.2 F-CHIP (function chip)

The F-CHIP is a microprocessor module that contains additional software packages with which the functionality, and thus the range of application, of the transmitter can be extended.

The F-CHIP is available as an accessory for subsequent retrofitting and can be simply plugged into the I/O board. The transmitter can access this software immediately after startup.

Accessories →  101

Plugging into the I/O board →  114



Caution!

To ensure unique F-CHIP assignment, the F-CHIP bears the serial number of the transmitter as soon as it has been plugged into the I/O board. This means that the F-CHIP cannot be used for any other device afterwards.

7 Maintenance

The flow measuring system Prosonic Flow 93 requires no special maintenance.

Exterior cleaning

When cleaning the exterior of measuring devices, always use cleaning agents that do not attack the surface of the housing and the seals.

Coupling fluid

A coupling fluid is required to ensure the acoustic link between the sensor and the piping. This is applied to the sensor surface during commissioning. Periodic replacement of the coupling fluid is usually not required.



Note!

- Clean and reapply new coupling fluid when sensor is removed from the pipe.
- Avoid to use a thick layer of the coupling fluid (less is more).
- On rough pipe surface e.g. GRP pipes ensure that the gaps crevices within the surface roughness are filled. Apply sufficient coupling fluid.
- On rough pipe surfaces where a thickened layer of coupling fluid has been applied the risk for dust collection on washing away is present. In such cases it is recommended to seal the external gap between the sensor holder and the pipe surface e.g. with.
- A change in the signal strength might indicate a change of the coupling fluid. No action is required as long as the signal strength is higher than 50 dB.

8 Accessories

Various accessories, which can be ordered separately from Endress+Hauser, are available for the transmitter and the sensor. The Endress+Hauser service organization can provide detailed information on the order codes on request.

Device-specific accessories

Accessory	Description	Order code
Wall-mount housing, transmitter Prosonic Flow 93	Transmitter for replacement or for stock. Use the order code to define the following specifications: <ul style="list-style-type: none"> ■ Approvals ■ Degree of protection/version ■ Cable entry ■ Display / power supply / operation ■ Software ■ Outputs / inputs 	Single-channel version: 93XXX - XX1XX***** Two-channel version: 93XXX - XX2XX*****
Conversion kit, inputs/outputs	Conversion kit with appropriate plug-in point modules for converting the current input/output configuration to a new version.	DK9UI - **
Sensor P (DN 15 to 65 / ½ to 2½") Clamp-on version	DN 15 to 65 (½ to 2½") <ul style="list-style-type: none"> ■ -40 to +100 °C (-40 to +212 °F) ■ -40 to +150 °C (-40 to +302 °F) 	DK9PS - 1* DK9PS - 2*
Sensor P (DN 50 to 4000 / 2 to 160") Clamp-on version	DN 50 to 300 (2 to 12") <ul style="list-style-type: none"> ■ -40 to +80 °C (-40 to +176 °F) ■ -40 to +170 °C (-40 to +338 °F) DN 100 to 4000 (4 to 160") <ul style="list-style-type: none"> ■ -40 to +80 °C (-40 to +176 °F) ■ -40 to +170 °C (-40 to +338 °F) 	DK9PS - B* DK9PS - F* DK9PS - A* DK9PS - E*
Sensor W (DN 15 to 65 / ½ to 2½") Clamp-on version	DN 15 to 65 (½ to 2½"), -40 to +80 °C (-4 to +176 °F), 6.0 MHz <ul style="list-style-type: none"> ■ IP 67 / NEMA 4X ■ IP 68 / NEMA 6P DN 15 to 65 (½ to 2½"), -40 to +130 °C (-4 to +266 °F), 6.0 MHz <ul style="list-style-type: none"> ■ IP 67 / NEMA 4X ■ IP 68 / NEMA 6P 	DK9WS -1 DK9WS -3 DK9WS -2 DK9WS -4
Sensor W (DN 50 to 4000 / 2 to 160") Clamp-on version	DN 50 to 300 (2 to 12"), -20 to +80 °C (-4 to +176 °F), 2.0 MHz <ul style="list-style-type: none"> ■ IP 67 / NEMA 4X ■ IP 68 / NEMA 6P DN 100 to 4000 (4 to 160"), -20 to +80 °C (-4 to +176 °F), 1.0 MHz <ul style="list-style-type: none"> ■ IP 67 / NEMA 4X ■ IP 68 / NEMA 6P DN 100 to 4000 (4 to 160"), 0 to +130 °C (+32 to +266 °F), 1.0 MHz <ul style="list-style-type: none"> ■ IP 67 / NEMA 4X DN 50 to 300 (2 to 12"), 0 to +130 °C (+32 to +266 °F), 2.0 MHz <ul style="list-style-type: none"> ■ IP 67 / NEMA 4X DN 100 to 4000 (4 to 160"), -20 to +80 °C (-4 to +176 °F), 0.5 MHz <ul style="list-style-type: none"> ■ IP 67 / NEMA 4X ■ IP 68 / NEMA 6P 	DK9WS - B* DK9WS - N* DK9WS - A* DK9WS - M* DK9WS - P* DK9WS - S* DK9WS - R* DK9WS - T*
Sensor W (DN 200 to 4000 / 8 to 160") Insertion version	DN 200 to 4000 (8 to 160"), -40 to +80 °C (-40 to +176 °F)	DK9WS - K*

Accessory	Description	Order code
Sensor DDU18	Sensor for sound velocity measurement <ul style="list-style-type: none"> ■ -40 to +80 °C (-40 to +176 °F) ■ 0 to +170 °C (+32 to +338 °F) 	50091703 50091704
Sensor DDU19	Sensor for wall thickness measurement.	50091713

Measuring principle-specific accessories

Accessory	Description	Order code
Mounting kit for aluminum field housing	Mounting kit for wall-mount housing. Suitable for: <ul style="list-style-type: none"> ■ Wall mounting ■ Pipe mounting ■ Panel mounting 	DK9WM - A
Mounting kit for field housing	Mounting kit for aluminum field housing: Suitable for pipe mounting (¾ to 3")	DK9WM - B
Sensor holder set	<ul style="list-style-type: none"> ■ Prosonic Flow P and W (DN 15 to 65 / ½ to 2½"): Sensor holder, Clamp-on version ■ Prosonic Flow P and W (DN 50 to 4000 / 2 to 160") <ul style="list-style-type: none"> – Sensor holder, fixed retaining nut, Clamp-on version – Sensor holder, removable retaining nut, Clamp-on version 	DK9SH - 1 DK9SH - A DK9SH - B
Clamp-on installation set Clamp-on	<p>Sensor fastening for Prosonic Flow P and W (DN 15 to 65 / ½ to 2½")</p> <ul style="list-style-type: none"> ■ U-shaped screw DN 15 to 32 (½ to 1¼") ■ Strapping bands DN 40 to 65 (1½ to 2½") <p>Sensor fastening for Prosonic Flow P and W (DN 50 to 4000 / 2 to 160")</p> <ul style="list-style-type: none"> ■ Without sensor fastening ■ Strapping bands DN 50 to 200 (2 to 8") ■ Strapping bands DN 200 to 600 (8 to 24") ■ Strapping bands DN 600 to 2000 (24 to 80") ■ Strapping bands DN 2000 to 4000 (80 to 160") ■ Without mounting tools ■ Assembly jig DN 50 to 200 (2 to 8") ■ Assembly jig DN 200 to 600 (8 to 24") ■ Mounting rail DN 50 to 200 (2 to 8") ■ Mounting rail DN 200 to 600 (8 to 24") 	DK9IC - 1* DK9IC - 2* DK9IC - A* DK9IC - B* DK9IC - C* DK9IC - D* DK9IC - E* DK9IC - *1 DK9IC - *2 DK9IC - *3 DK9IC - *4 DK9IC - *5
Conduit adapter for connecting cable	<p>Prosonic Flow P and W (DN 15 to 65 / ½ to 2½")</p> <ul style="list-style-type: none"> ■ Conduit adapter incl. cable entry M20 × 1.5 ■ Conduit adapter incl. cable entry ½" NPT ■ Conduit adapter incl. cable entry G½" <p>Prosonic Flow P and W (DN 50 to 4000 / 2 to 160")</p> <ul style="list-style-type: none"> ■ Conduit adapter incl. cable entry M20 × 1.5 ■ Conduit adapter incl. cable entry ½" NPT ■ Conduit adapter incl. cable entry G½" 	DK9CB - BA1 DK9CB - BA2 DK9CB - BA3 DK9CB - BB1 DK9CB - BB2 DK9CB - BB3

Accessory	Description	Order code
Connecting cable for Prosonic Flow P/W	Prosonic Flow P and W (DN 15 to 65 / ½ to 2½") 5 m sensor cable, TPE-V, -20 to +70 °C (-4 to +158 °F) 10 m sensor cable, TPE-V, -20 to +70 °C (-4 to +158 °F) 15 m sensor cable, TPE-V, -20 to +70 °C (-4 to +158 °F) 30 m sensor cable, TPE-V, -20 to +70 °C (-4 to +158 °F) Prosonic Flow P/W (DN 50 to 4000 / 2 to 160") 5 m sensor cable, PVC, -20 to +70 °C (-4 to +158 °F) 10 m sensor cable, PVC, -20 to +70 °C (-4 to +158 °F) 15 m sensor cable, PVC, -20 to +70 °C (-4 to +158 °F) 30 m sensor cable, PVC, -20 to +70 °C (-4 to +158 °F) 5 m sensor cable, PTFE, -40 to +170 °C (-40 to +338 °F) 10 m sensor cable, PTFE, -40 to +170 °C (-40 to +338 °F) 15 m sensor cable, PTFE, -40 to +170 °C (-40 to +338 °F) 30 m sensor cable, PTFE, -40 to +170 °C (-40 to +338 °F)	DK9SS - BAA DK9SS - BAB DK9SS - BAC DK9SS - BAD DK9SS - BBA DK9SS - BBB DK9SS - BBC DK9SS - BBD DK9SS - BBE DK9SS - BBF DK9SS - BBG DK9SS - BBH
Acoustic coupling fluid	<ul style="list-style-type: none"> ■ Coupling fluid -40 to +170 °C (-40 to 338 °F), high temperature, standard ■ Adhesive coupling fluid -40 to +80 °C (-40 to +176 °F) ■ Water-soluble coupling fluid -20 to +80 °C (-4 to +176 °F) ■ Coupling fluid DDU 19, -20 to +60 °C (-4 to +140 °F) ■ Coupling fluid -40 to +100 °C (-40 to +212 °F), standard, type MBG2000 	DK9CM - 2 DK9CM - 3 DK9CM - 4 DK9CM - 6 DK9CM - 7

Communication-specific accessories

Accessory	Description	Order code
HART handheld terminal FieldXpert	Handheld terminal for remote configuration and for obtaining measured values via the HART current output (4 to 20 mA) and FOUNDATION Fieldbus. Contact your Endress+Hauser representative for more information.	SFX100 - *****
Fieldgate FXA320	Gateway for remote interrogation of HART sensors and actuators via Web browser: <ul style="list-style-type: none"> ■ 2-channel analog input (4 to 20 mA) ■ 4 binary inputs with event counter function and frequency measurement ■ Communication via modem, Ethernet or GSM ■ Visualization via Internet/Intranet in the Web browser and/or WAP cellular phone ■ Limit value monitoring with alarm signaling via e-mail or SMS ■ Synchronized time stamping of all measured values. 	FXA320 - *****
Fieldgate FXA520	Gateway for remote interrogation of HART sensors and actuators via Web browser: <ul style="list-style-type: none"> ■ Web server for remote monitoring of up to 30 measuring points ■ Intrinsically safe version [Ex ia]IIC for applications in hazardous areas ■ Communication via modem, Ethernet or GSM ■ Visualization via Internet/Intranet in the Web browser and/or WAP cellular phone ■ Limit value monitoring with alarm signaling via e-mail or SMS ■ Synchronized time stamping of all measured values ■ Remote diagnosis and remote configuration of connected HART devices 	FXA520 - ****
FXA195	The Commubox FXA195 connects intrinsically safe Smart transmitters with HART protocol to the USB port of a personal computer. This makes the remote operation of the transmitters possible with the aid of configuration programs (e.g. FieldCare). Power is supplied to the Commubox by means of the USB port	FXA195 - *

Service-specific accessories

Accessory	Description	Order code
Applicator	Software for selecting and planning flowmeters. The Applicator can be downloaded from the Internet or ordered on CD-ROM for installation on a local PC. Contact your Endress+Hauser representative for more information.	DXA80 – *
Fieldcheck	Tester/simulator for testing flowmeters in the field. When used in conjunction with the "FieldCare" software package, test results can be imported into a database, printed and used for official certification. Contact your Endress+Hauser representative for more information.	50098801
FieldCare	FieldCare is Endress+Hauser's FDT-based plant asset management tool. It can configure all intelligent field units in your system and helps you manage them. By using the status information, it is also a simple but effective way of checking their status and condition.	See the product page on the Endress+Hauser website: www.endress.com
FXA193	Service interface from the measuring device to the PC for operation via FieldCare.	FXA193 – *
Communication cable	Communication cable for connecting the Prosonic Flow 93 transmitter to the FXA193 service interface.	DK9ZT – A



9 Troubleshooting

9.1 Troubleshooting instructions

Always start troubleshooting with the following checklist if faults occur after commissioning or during operation. The routine takes you directly to the cause of the problem and the appropriate remedial measures.

Check the display	
No display visible and no output signals present.	<ol style="list-style-type: none"> 1. Check the supply voltage → Terminals 1, 2 2. Check device fuse → 117 85 to 260 V AC: 0.8 A slow-blow / 250 V 20 to 55 V AC and 16 to 62 V DC: 2 A slow-blow / 250 V 3. Meter electronics defective → Order spare part → 113
No display visible, but output signals are present.	<ol style="list-style-type: none"> 1. Check whether the ribbon-cable connector of the display module is correctly plugged into the amplifier board → 114 2. Display module defective → Order spare part → 113 3. Meter electronics defective → Order spare part → 113
Display texts are in a foreign language.	Switch off power supply. Press and hold down both the  keys and switch on the measuring device. The display text will appear in English (default) and is displayed at maximum contrast.
Measured value indicated, but no signal output at the current or pulse output.	<ol style="list-style-type: none"> 4. Measuring electronics board defective → Order spare part → 113



Error messages on display	
<p>Errors that occur during commissioning or measuring are displayed immediately. Error messages consist of a variety of icons. The meanings of these icons are as follows:</p> <ul style="list-style-type: none"> – Type of error: S = System error, P = Process error – Error message type:  = Fault message,  = Notice message – S.V. RANGE CH1 = error designation (e.g. sound velocity for channel 1 is outside the measuring range) – 03:00:05 = duration of error occurrence (in hours, minutes and seconds) – #492 = error number <p> Caution!</p> <ul style="list-style-type: none"> ■ See the information on → 71! ■ The measuring system interprets simulations and positive zero return as system errors, but displays them as notice messages only. 	
Error number: No. 001 – 399 No. 501 – 799	System error (device error) has occurred → 106
Error number: No. 401 – 499	Process error (application error) has occurred → 110



Other error (without error message)	
Some other error has occurred.	Diagnosis and rectification → 111

9.2 System error messages

Serious system errors are **always** recognized by the instrument as "Fault message" and are shown as a lightning flash (⚡) on the display! Fault messages immediately affect the inputs and outputs.



Caution!

In the event of a serious fault, a flowmeter might have to be returned to the manufacturer for repair. Important procedures must be carried out before you return a flowmeter to Endress+Hauser.

→ 6

Always enclose a duly completed "Declaration of Contamination" form. A copy of the form can be found at the end of these Operating Instructions!



Note!

See the information on → 80.

No.	Error message/type	Cause	Remedy (spare parts → 101)
S = System error ⚡ = Fault message (with an effect on the outputs) ! = Notice message (without any effect on the outputs)			
No. # 0xx → Hardware error			
001	S: CRITICAL FAILURE ⚡: # 001	Critical device error.	Replace the amplifier board.
011	S: AMP HW EEPROM ⚡: # 011	Amplifier: Faulty EEPROM	Replace the amplifier board.
012	S: AMP SW EEPROM ⚡: # 012	Amplifier: Error when accessing data of the EEPROM.	The EEPROM data blocks in which an error occurred are displayed in the TROUBLESHOOTING function. The errors in question have to be confirmed with the Enter key; faulty parameters are then replaced by predefined standard values. Note! The device has to be restarted if an error occurs in the totalizer block (see also error no. 111 / CHECKSUM TOTAL.).
041	S: TRANSM. HW-DAT ⚡: # 041	1. T-DAT is not plugged into the amplifier board correctly (or is missing). 2. T-DAT is defective.	1. Check whether the T-DAT is correctly plugged into the amplifier board. 2. Replace the T-DAT if it is defective. Check that the new, replacement DAT is compatible with the measuring electronics. Check the: - Spare part set number - Hardware revision code 3. Replace measuring electronics board if necessary.
042	S: TRANSM. SW-DAT ⚡: # 042		
051	S: A / C COMPATIB. ⚡: # 051	The I/O board and the amplifier board are not compatible.	Use only compatible modules and boards. Check the compatibility of the modules used. Check the:: ■ Spare part set number ■ Hardware revision code
061	S: HW F-CHIP ⚡: # 061	1. F-Chip is not plugged into the I/O board or is missing. 2. F-Chip is defective.	1. Plug the F-Chip into the I/O board. 2. Replace the F-Chip.
082	S: SENS. DOWN CH1 ⚡: # 082	Connection between sensor channel 1/2 and transmitter interrupted.	■ Check the cable connection between the sensor and the transmitter. ■ Check that the sensor connector is fully screwed in.. ■ The sensor may be defective. ■ Incorrect sensor connected. ■ The wrong sensor was selected in the SENSOR TYPE (No. 6881) function.
083	S: SENS. DOWN CH2 ⚡: # 083		
085	S: SENS. UP CH1 ⚡: # 085		
086	S: SENS. UP CH2 ⚡: # 086		
No. # 1xx → Software error			
111	S: CHECKSUM TOT. ⚡: # 111	Totalizer checksum error.	1. Restart the measuring device. 2. Replace the amplifier board if necessary.

No.	Error message/type	Cause	Remedy (spare parts → 101)
121	S: A/C COMPATIB. !: # 121	Due to different software versions, I/O board and amplifier board are only partially compatible (possibly restricted functionality).  Note! Nothing is displayed on the display. This message is only listed in the error history.	Module with lower software version has either to be updated by FieldCare with the required software version or the module has to be replaced.
No. # 2xx → Error with DAT / no data reception			
205	S: LOAD T-DAT !: # 205	DAT transmitter: Data backup (download) to T-DAT failed, or error when accessing (uploading) the values stored in the T-DAT.	1. Check whether the T-DAT is correctly plugged into the amplifier board. 2. Replace the T-DAT if it is defective. Before replacing a DAT, check that the new, replacement DAT is compatible with the measuring electronics. Check the: – Spare part set number – Hardware revision code 3. Replace measuring electronics board if necessary.
206	S: SAVE T-DAT !: # 206		
251	S: COMMUNIC. I/O !: # 251	Internal communication error on the amplifier board.	Replace the amplifier board.
261	S: COMMUNIC. I/O !: # 261	No data reception between amplifier and I/O board or faulty internal data transfer.	Check BUS contacts
No. # 3xx → System range limits exceeded			
339 to 342	S: STACK CUR. OUT n !: # 339 to 342	The buffering of the flow components (measuring mode with pulsating flow) could not be calculated and output within 60 seconds.	1. Change the start and end values entered 2. Increase or reduce flow The following is recommended if the error category is FAULT MESSAGE (‡): – Configure the failsafe mode of the output to "ACTUAL VALUE" so that the buffer can be reduced. – Clear the buffer by using the measure indicated in Point 1.
343 to 346	S: STACK FRQ. OUT n !: # 343 to 346		
347 to 350	S: STACK PULSE n !: # 347 to 350	The buffering of the flow components (measuring mode with pulsating flow) could not be calculated and output within 60 seconds.	1. Increase the pulse value entered 2. Increase the max. pulse frequency if the counter can still process the number of pulses. 3. Increase or reduce flow. The following is recommended if the error category is FAULT MESSAGE (‡): – Configure the failsafe mode of the output to "ACTUAL VALUE" so that the buffer can be reduced. – Clear the buffer by using the measure indicated in Point 1.
351 to 354	S: RANGE CUR. OUT n !: # 351 to 354	Current output: The current flow is outside the set range.	1. Change the start and end values entered 2. Increase or reduce flow
355 to 358	S: RANGE FRQ. OUT n !: # 355 to 358	Frequency output: The current flow is outside the set range.	1. Change the start and end values entered 2. Increase or reduce flow
359 to 362	S: RANGE PULSE !: # 359 to 362	Pulse output: The pulse output frequency is outside the set range.	1. Increase the pulse value entered 2. When entering the pulse width, select a value that can still be processed by a connected totalizer (e.g. mechanical totalizer, PLC, etc.). Determine pulse width: – Method 1: the minimum time for which a pulse has to be present at a connected totalizer in order to be recorded is entered. – Method 2: the maximum (pulse) frequency is entered as a half "reciprocal value" for which a pulse has to be present at a connected totalizer in order to be recorded. Example: The maximum input frequency of the connected counter is 10 Hz. The pulse width to be entered is: $\frac{1}{2 \cdot 10 \text{ Hz}} = 50 \text{ ms}$ 3. Reduce flow

a0004437

No.	Error message/type	Cause	Remedy (spare parts → 101)
392	S: SIGNAL LOW CH1 !: # 392	Attenuation of acoustic measurement section too high.	<ul style="list-style-type: none"> ■ Check to see if the coupling fluid must be renewed ■ It is possible that the fluid indicates too much attenuation ■ It is possible that the pipe indicates too much attenuation ■ Check the sensor spacing (Installation dimensions) ■ Reduce the number of traverses if possible
393	S: SIGNAL LOW CH2 !: # 393		
No # 5xx → Application errors			
501	S: SW.-UPDATE ACT. !: # 501	New amplifier or communication module software version being loaded. Currently no other functions are possible.	Wait until the procedure is complete. The device will restart automatically.
502	S: UP-/DOWNLOAD ACT. !: # 502	Up- or downloading the device data via operating program. Currently no other functions are possible.	Wait until the procedure is complete.
592	S: INIT. RUN CH1 !: # 592	Channel 1/2 initialization running. All outputs set to 0.	Wait until the procedure is complete.
593	S: INIT. RUN CH2 !: # 593		
No. # 6xx → Simulation operation active			
602	S: POS.0-RET.CH1 !: # 602	Positive zero return channel CH1, CH2 or CH1&2 active. ⚠ Caution! This notice message has the highest display priority!	Switch off positive zero return.
603	S: POS.0-RET.CH2 !: # 603		
604	S: POS.0-RT.CH1&2 !: # 604		
611 to 614	S: SIM. CURR OUT. n !: # 611 to 614	Current output simulation active.	
621 to 624	S: SIM. FREQ. OUT n !: # 621 to 624	Frequency output simulation active.	Switch off simulation.
631 to 634	S: SIM. PULSE n !: # 631 to 634	Pulse output simulation active.	Switch off simulation.
641 to 644	S: SIM. STAT. OUT n !: # 641 to 644	Status output simulation active.	Switch off simulation.
651 to 654	S: SIM. REL. OUT n !: # 651 to 654	Relay output simulation active.	Switch off simulation.
661 to 664	S: SIM. CURRENT IN. n !: # 661 to 664	Current input simulation active.	Switch off simulation.
671 to 674	S: SIM. STATUS IN. n !: # 671 to 674	Status input simulation active.	Switch off simulation.
691	S: SIM. FAILSAFE !: # 691	Simulation of failsafe mode (outputs) active.	Switch off simulation.
694	S: SIM..MEASUR.CH1 !: # 694	Channel 1/2: Volume flow simulation active.	Switch off simulation.
695	S: SIM..MEASUR.CH2 !: # 695		
696	S: SIM. FAILSAFE.CH1 !: # 696	Simulation of response to error of channel 1/2 (outputs) active.	Switch off simulation.
697	S: SIM. FAILSAFE.CH2 !: # 697		

No.	Error message/type	Cause	Remedy (spare parts → 101)
698	S: DEV. TEST ACT. !: # 698	The measuring device is being checked on site via the test and simulation device.	–
Nr. # 7xx → Calibration or acton errors			
743 to 745	S: 0-ADJ.FAIL CHn !: # 743 to 745	The static zero point calibration of Channel 1/2 is not possible or was interrupted.	Check that the flow velocity is = 0 m/s.
752	S: W. THICKNESS CH 1 !: # 752	Channel 1: Wall thickness measurement active	Switch off wall thickness measurement
753	S: W. THICKNESS CH 2 !: # 753	Channel 2: Wall thickness measurement active	Switch off wall thickness measurement
754	S: CALIBR. CH 1 !: # 754	Channel 1: Wall thickness calibration active	Wait until procedure is finished
755	S: CALIBR. CH 2 !: # 755	Channel 2: Wall thickness calibration active	Wait until procedure is finished
757	S: CALIBR.FAIL. CH 1 !: # 757	Channel 1: Wall thickness calibration failed	Check sensor- and cable connections. Ensure coupling fluid is applied to the sensor.
758	S: CALIBR.FAIL. CH 2 !: # 758	Channel 2: Wall thickness calibration failed	Check sensor- and cable connections. Ensure coupling fluid is applied to the sensor.
No. # 8xx → Additional error messages with software options (ultrasonic flowmeters)			
810	S: D. VOL. FLOW CH1 !: # 810	Advanced diagnostics: The volume flow is outside the range specified in the diagnostic functions.	–
820	S: D. VOL. FLOW CH2 !: # 820		–
811	S: D. FLOW VEL.CH1 !: # 811	Advanced diagnostics: The flow velocity is outside the range specified in the diagnostic functions.	–
821	S: D. FLOW VEL. CH2 !: # 821		–
812	S: D. SIGNAL CH1 !: # 812	Advanced diagnostics: The signal strength is outside the range specified in the diagnostic functions.	–
822	S: D. SIGNAL CH2 !: # 822		–
813	S: D. SOUND V. CH1 !: # 813	Advanced diagnostics: The sound velocity is outside the range specified in the diagnostic functions.	–
823	S: D. SOUND V. CH2 !: # 823		–
814	S: D. T.TIME CH1 !: # 814	Advanced diagnostics: The transit time is outside the range specified in the diagnostic functions.	–
824	S: D. T.TIME CH2 !: # 824		–
815	S: D. ACC.RATE CH1 !: # 815	Advanced diagnostics: The volume flow is outside the range specified in the diagnostic functions.	–
825	S: D. ACC.RATE CH2 !: # 825		–
830	S: D. VOL. FLOW AVG !: # 830	Advanced diagnostics: The average flow velocity is outside the range specified in the diagnostic functions.	–
831	S: D. FLOW VEL.AVG !: # 831		–
833	S: D. SOUND V. AVG !: # 833	Advanced diagnostics: The average sound velocity is outside the limit value, set in the corresponding diagnosis function.	–

9.3 Process error messages

Process errors can be defined as either "Fault" or "Notice" messages and can thus be weighted differently. This is specified by means of the function matrix (→ "Description of Device Functions" manual).







Note!

See the information on → 70 ff. and → 111.

Type	Error message / No.	Cause	Remedy
P = Process error ⚡ = Fault message (with an effect on the inputs/outputs) ! = Notice message (without any effect on the inputs/outputs)			
P ⚡	PIPE DATA? CH1 # 469	The internal diameter is negative.	In the "PIPE DATA" function group, check the values of the functions "OUTER DIAMETER" and "WALL THICKNESS" or "LINING THICKNESS".
P ⚡	PIPE DATA? CH2 # 470		
P ⚡	S. V. RANGE CH1 # 492	The sound velocity in channel 1/2 is outside the search range of the transmitter.	– Check the installation dimensions. – If possible, check the sound velocity of the liquid or check the specialist literature.
P ⚡	S. V. RANGE CH2 # 493	The pipe transmitted signal may superimpose the raw flow signal.	If the current sound velocity is outside the defined search range, the corresponding function must be changed in the LIQUID DATA function group. Detailed information can be found under the SOUND VELOCITY LIQUID function (6542) in the Description of Device Functions for Prosonic Flow 93 manual (BA 071D/06/en).
P !	INTERF. CH1 # 495	The wave transmitted in the pipe may superimpose the signal. We recommend you alter the sensor configuration in the event of this error message.  Caution! The sensor configuration must be changed if the measuring device indicates zero flow or low flow.	In the SENSOR CONFIGURATION function (6882), change the number of traverses from 2 or 4 to 1 or 3 and mount the sensors accordingly.
P !	INTERF. CH2 # 496		

9.4 Process errors without messages

Symptoms	Rectification
 Note! You may have to change or correct certain settings of the function matrix in order to rectify faults. The functions outlined below, e.g. DISPLAY DAMPING, are described in detail in the "Description of Device Functions" manual.	
Negative flow values displayed even though the fluid is flowing forwards in the pipe.	<ol style="list-style-type: none"> 1. Check the wiring →  58. If necessary, switch the connections for the terminals for "up" and "down". 2. Change the "INSTL. DIR. SENSOR" function accordingly.
Measured value reading fluctuates even though flow is steady.	<ol style="list-style-type: none"> 1. Check the fluid for presence of gas bubbles. 2. "TIME CONSTANT" function (current output) → Increase value 3. "DISPLAY DAMPING" function → Increase value
The measured value display or measured value output is pulsating or fluctuating, e.g. due to reciprocating pumps, peristaltic pumps, diaphragm pumps or pumps with similar transporting characteristics.	Run the "Pulsating Flow" Quick Setup →  88. If these measures do not rectify the problem, a pulsation damper has to be installed between the pump and the flowmeter.
There are differences between the internal totalizer of the flowmeter and the external counter.	This error occurs particularly when backflow occurs in the pipe since the pulse output cannot subtract in the "STANDARD" or "SYMMETRY" measuring mode. The solution is as follows: Flow in both flow directions should be taken into account. The "MEASURING MODE" function should be set to "PULSATING FLOW" for the pulse input in question.
Measured value reading shown on display, even though the fluid is at a standstill and the measuring tube is full.	<ol style="list-style-type: none"> 1. Check the fluid for presence of gas bubbles. 2. Activate the "LOW FLOW CUTOFF" function, i.e. enter or increase the value for the switch point.
The current output signal is always 4 mA, regardless of the current flow signal.	<ol style="list-style-type: none"> 1. Set the "BUS ADDRESS" function to "0". 2. Low flow cutoff is too high. Reduce the value in the "LOW FLOW CUTOFF" function.
The fault cannot be rectified or some other fault not described above has occurred. In these instances, please contact your Endress+Hauser service organization.	The following options are available for tackling problems of this nature: Request the services of an Endress+Hauser service technician If you contact our service organization to have a service technician sent out, please be ready with the following information: <ul style="list-style-type: none"> – Brief description of the fault – Nameplate specifications: order code and serial number Return devices to Endress+Hauser The measures listed must be carried out before you return a measuring device requiring repair or calibration to Endress+Hauser. Always enclose the duly completed "Declaration of Contamination" form with the flowmeter. You will find a preprinted blank of this form at the back of this manual. Replace transmitter electronics Components in the measuring electronics defective → Order spare part →  113



9.5 Response of outputs to errors



Note!

The failsafe mode of the totalizers, current output, pulse output and frequency output can be configured by means of various functions in the function matrix. More detailed information on this is provided in the "Description of Device Functions" manual.

You can use positive zero return to set the signals of the current, pulse and frequency outputs to their fallback value, for example when operation has to be interrupted while a pipe is being cleaned. This function has priority over all other device functions; simulations are suppressed, for example.

Error response mode of outputs and totalizers		
	Process/system error present	Positive zero return activated
<p> Caution! System or process errors defined as "notice messages" have no effect whatsoever on the inputs and outputs. See the information on →  71 ff.</p>		
Current output	<p>MIN. CURRENT Depending on the option selected in the CURRENT SPAN function (see "Description of Device Functions" manual), the current output is set to the value of the lower signal on alarm level.</p> <p>MAX. CURRENT Depending on the option selected in the CURRENT SPAN function (see "Description of Device Functions" manual), the current output is set to the value of the upper signal on alarm level.</p> <p>HOLD VALUE Measured value output is based on the last measured value saved before the error occurred.</p> <p>ACTUAL VALUE Measured value output is based on the current flow measurement. The fault is ignored.</p>	Output signal corresponds to "zero flow".
Pulse output	<p>FALLBACK VALUE Signal output → No pulses</p> <p>HOLD VALUE The last valid measured value (before the error occurred) is output.</p> <p>ACTUAL VALUE The fault is ignored, i.e. the measured value is output as normal on the basis of the current flow measurement.</p>	Output signal corresponds to "zero flow".
Frequency output	<p>FALLBACK VALUE Signal output → 0 Hz</p> <p>FAILSAFE LEVEL The frequency specified in the FAILSAFE LEVEL function (4211) is output.</p> <p>HOLD VALUE The last valid measured value (before the error occurred) is output.</p> <p>ACTUAL VALUE The fault is ignored, i.e. the measured value is output as normal on the basis of the current flow measurement.</p>	Output signal corresponds to "zero flow".
Totalizer	<p>STOP The totalizers stop if a fault is present.</p> <p>ACTUAL VALUE The fault is ignored. The totalizers continue to count in accordance with the current flow measured value.</p> <p>HOLD VALUE The totalizers continue to count in accordance with the last valid flow measured value (before the fault occurred).</p>	The totalizer stops.
Relay output	<p>If a fault occurs or the power supply fails: relay → Deenergized</p> <p>The "Description of Device Functions" manual provides you with detailed information on the switching behavior of the relays with different configurations, such as fault message, flow direction, limit value, etc.</p>	No effect on the relay output

9.6 Spare parts

The previous sections contain a detailed troubleshooting guide → 105.

The measuring device, more over, provides additional support in the form of continuous self-diagnosis and error messages.

Troubleshooting can entail replacing defective components with tested spare parts. The illustration below shows the available scope of spare parts.



Note!

You can order spare parts directly from your Endress+Hauser service organization by providing the serial number printed on the transmitter's nameplate → 7.

Spare parts are shipped as sets comprising the following parts:

- Spare part
- Additional parts, small items (fasteners, etc.)
- Mounting instructions
- Packaging

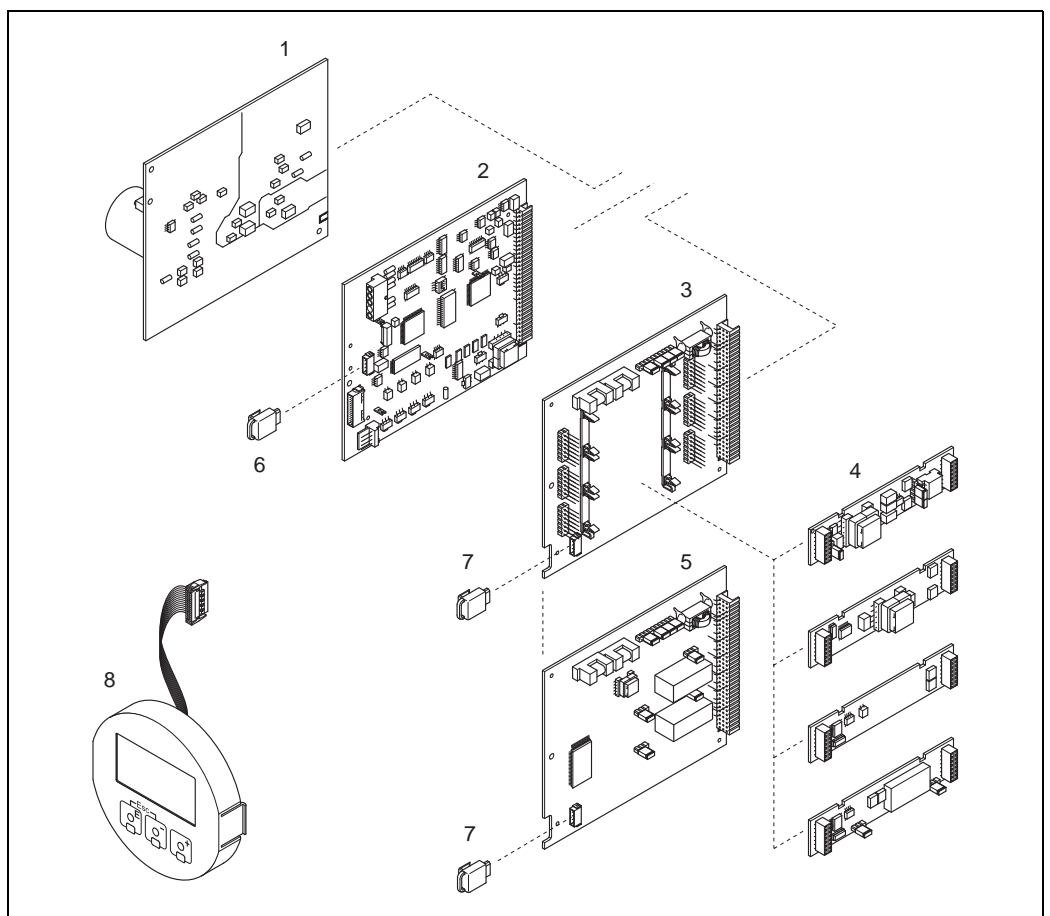

Fig. 88: Spare parts for Prosonic Flow 93 transmitter (wall-mount housing)

- 1 Power unit board (85 to 260 V AC, 20 to 55 V AC, 16 to 62 V DC)
- 2 Amplifier board
- 3 I/O board (flexible assignment)
- 4 Plug-in input/output submodules → 101
- 5 I/O board (permanent assignment)
- 6 T-DAT (transmitter data storage device)
- 7 F-CHIP (function chip for optional software)
- 8 Display module

9.7 Installing and removing electronics boards



Warning!

- Risk of electric shock. Exposed components carry dangerous voltages. Make sure that the power supply is switched off before you remove the cover of the electronics compartment.
- Risk of damaging electronic components (ESD protection). Static electricity can damage electronic components or impair their operability. Use a workplace with a grounded working surface, purposely built for electrostatically sensitive devices.
- If you cannot guarantee that the dielectric strength of the device is maintained in the following steps, then an appropriate inspection must be carried out in accordance with the manufacturer's specifications.

Procedure → 115

1. Remove the screws and open the housing cover (1).
2. Remove the screws securing the electronics module (2). Then push up electronics module and pull it as far as possible out of the wall-mount housing.
3. Disconnect the following cable connectors from amplifier board (7):
 - Sensor signal cable connector (7.1)
 - Ribbon cable connector (3) of the display module.
4. Remove the cover (4) from the electronics compartment by loosening the screws.
5. Remove the boards (6, 7, 8, 9):
Insert a thin pin into the hole provided (5) for the purpose and pull the board clear of its holder.
6. Remove the submodules (8.1):
No tools are required for removing the submodules (inputs/outputs) from the I/O board. Installation is also a no-tools operation.



Caution!

Only certain combinations of submodules on the I/O board are permissible (→ 62). The individual slots are marked and correspond to certain terminals in the connection compartment of the transmitter:

"INPUT / OUTPUT 2" slot = terminals 24/25

"INPUT / OUTPUT 3" slot = terminals 22/23

"INPUT / OUTPUT 4" slot = terminals 20/21

7. Installation is the reverse of the removal procedure.



Caution!

Use only original Endress+Hauser replacement parts.

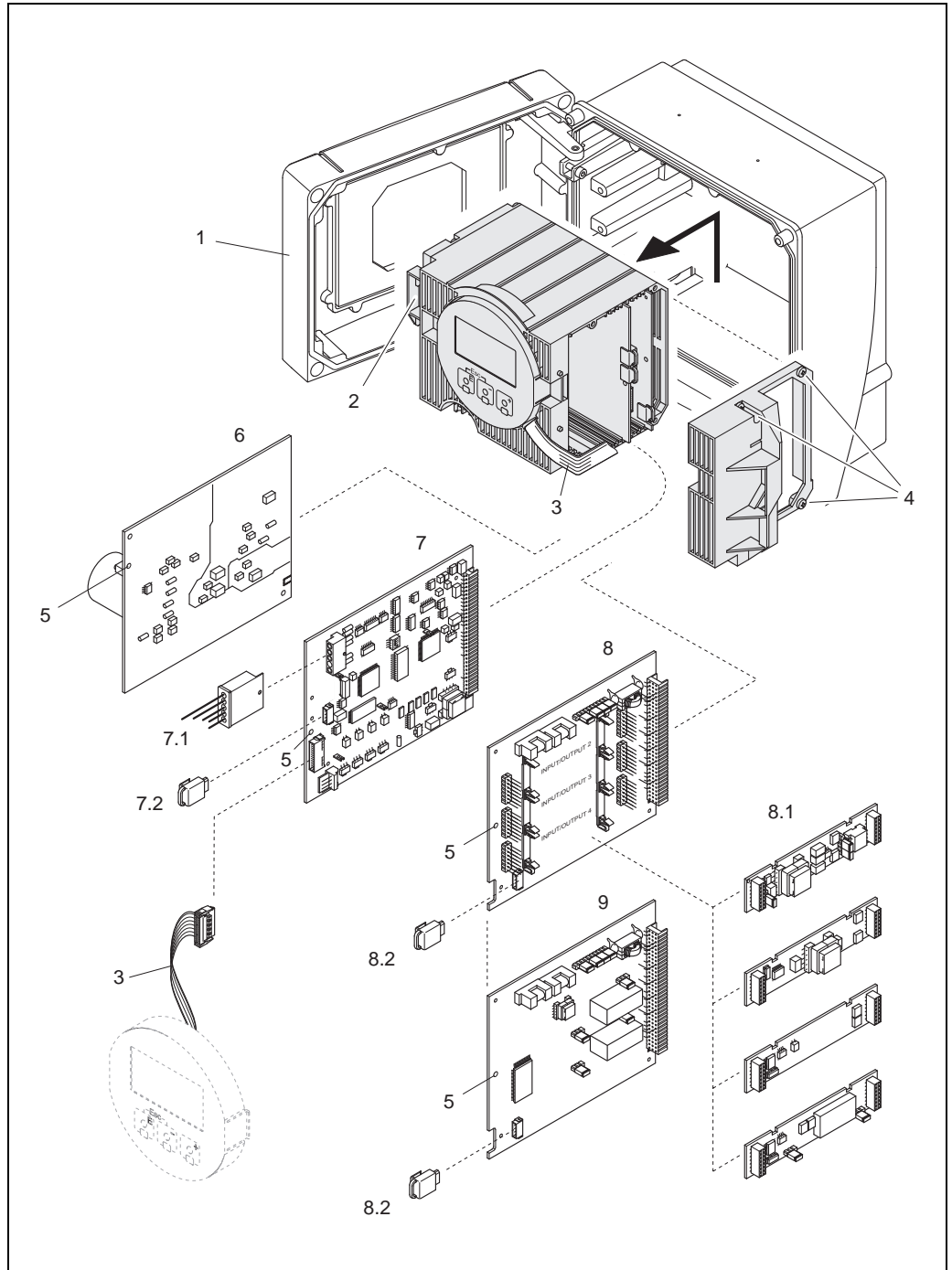

A0001218

Fig. 89: Wall-mount housing: removing and installing printed circuit boards

- 1 Housing cover
- 2 Electronics module
- 3 Ribbon cable (display module)
- 4 Screws of electronics compartment cover
- 5 Aperture for installation/removal
- 6 Power unit board
- 7 Amplifier board
- 7.1 Sensor signal cable (sensor)
- 7.2 T-DAT (transmitter data storage device)
- 8 I/O board (flexible assignment)
- 8.1 Plug-in submodules (status input; current output, frequency output and relay output)
- 8.2 F-CHIP (function chip for optional software)
- 9 I/O board (permanent assignment)

9.8 Installing and removing the W sensors

The active part of the flowrate measuring sensor W "Insertion version" can be replaced without interrupting the process.

1. Pull the sensor connector (1) out of the sensor cover (3).
2. Remove the small retainer ring (2). This is located on the top of the sensor neck and keeps the sensor cover in place.
3. Remove the sensor cover (3) and spring (4).
4. Remove the large retainer ring (5). This keeps the sensor neck (6) in place.
5. The sensor neck can now be pulled out. Note that you must reckon with a certain amount of resistance.
6. Pull the sensor element (7) out of the sensor retainer (8) and replace it with a new one.
7. Installation is the reverse of the removal procedure.

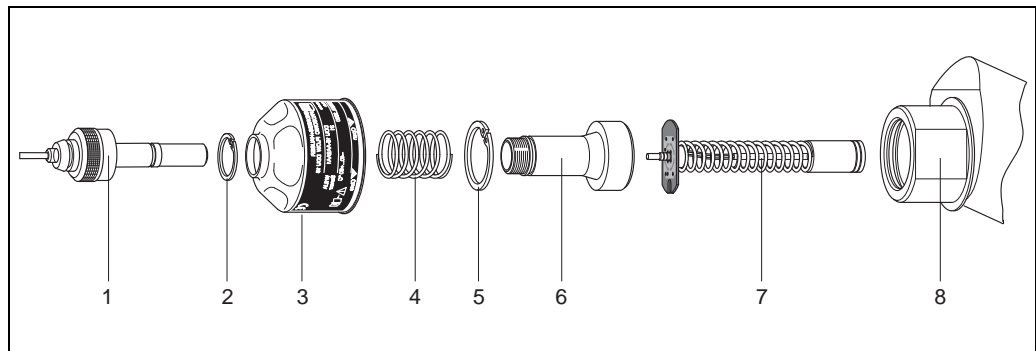

Fig. 90: Flowrate measuring sensor W "Insertion version"

- | | |
|---|---------------------|
| 1 | Sensor connector |
| 2 | Small retainer ring |
| 3 | Sensor cover |
| 4 | Spring |
| 5 | Large retainer ring |
| 6 | Sensor neck |
| 7 | Sensor element |
| 8 | Sensor retainer |

9.9 Replacing the device fuse



Warning!

Risk of electric shock. Exposed components carry dangerous voltages. Make sure that the power supply is switched off before you remove the cover of the electronics compartment.

The main fuse is on the power unit board. → 117

The procedure for replacing the fuse is as follows:

1. Switch off power supply.
2. Remove the power unit board. → Page 114.
3. Remove cap (1) and replace the device fuse (2).
Use only fuses of the following type:
 - 20 to 55 V AC / 16 to 62 V DC → 2.0 A slow-blow / 250 V; 5.2 × 20 mm
 - Power supply 85 to 260 V AC → 0.8 A slow-blow / 250 V; 5.2 × 20 mm
 - Ex-systems → See appropriate Ex documentation.
4. Installation is the reverse of the removal procedure.



Caution!

Use only original Endress+Hauser replacement parts.

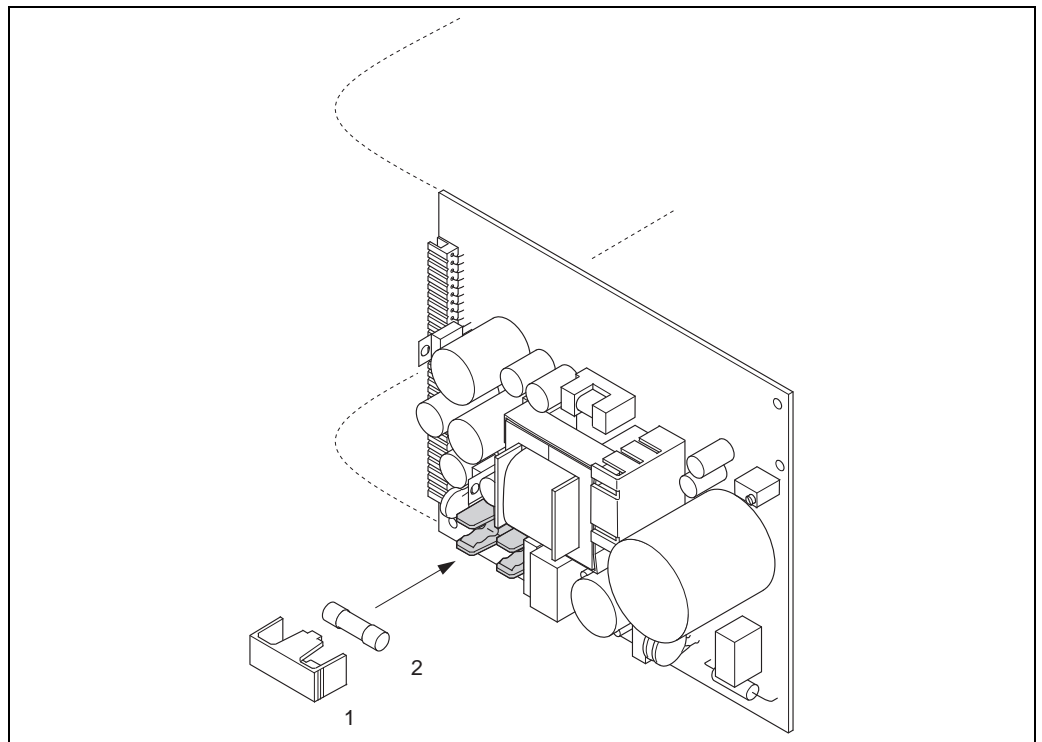

Fig. 91: Replacing the device fuse on the power unit board

- 1 Protective cap
2 Device fuse

9.10 Return

→ 6

9.11 Disposal

Observe the regulations applicable in your country!

9.12 Software history



Note!

Upload/download between different software versions is normally only possible with special service software.

Date	Software version	Changes to software	Operating Instructions
06.2011	2.03.XX	<ul style="list-style-type: none"> - Prosonic Flow W sensor (DN 15 to 65/½ to 2½") - Liner informaton added to Quick Setup - Additional ANSI pipes added to pipe standard 	71134382/06.11
07.2010	2.02.XX	No changes to software	71115157/07.10
06.2009	2.02.XX	<ul style="list-style-type: none"> - Prosonic Flow P sensor (DN 15 to 65 / ½ to 2½") - Signal strength output - New calibration date function 	71093707/06.09
07.2007	2.01.XX	Optimization of the measuring function	50099982/11.04 (no amendment necessary in documentation)
11.2004	2.00.XX	<p>Software expansion:</p> <ul style="list-style-type: none"> - Prosonic Flow P sensor - Chinese language group (contains English and Chinese) <p>New functionalities:</p> <ul style="list-style-type: none"> - DEVICE SOFTWARE → Device software displayed (NAMUR Recommendation 53) - REMOVE SW OPTION → Remove F-CHIP options - Output function <ul style="list-style-type: none"> 2 × current + 2 × pulse 2 × current + 2 × relay 	50099983/11.04
10.2003	Amplifier: 1.06.xx Communication module: 1.03.xx	<p>Software expansion:</p> <ul style="list-style-type: none"> - Language groups - Flow direction for pulse output can be selected <p>New functionalities:</p> <ul style="list-style-type: none"> - Operation hours counter - Intensity of background illumination adjustable - Pulse output simulation - Counter for access code - Error history reset function - Preparation for upload/download with Fieldtool - Advanced diagnostics: acquisition start via status input - Failsafe mode, channel-separate 	50099983/10.03
12.2002	Amplifier: 1.05.00	<p>Software expansion:</p> <ul style="list-style-type: none"> - Prosonic Flow U sensor - Prosonic Flow C Inline 	50099983/12.02
07.2002	Amplifier: 1.04.00 Communication module: 1.02.01	<p>Software expansion:</p> <ul style="list-style-type: none"> - "Advanced diagnostics" software function - Device functions: search area for liquid sound velocity redefined - New error messages <ul style="list-style-type: none"> PIPE DATA INTERFERENCE - Minimum sensor spacing for P and W sensors (180 mm) - CURRENT SPAN function: <ul style="list-style-type: none"> Additional selection options 	50099983/07.02
06.2001	Amplifier: 1.00.00 Communication module: 1.02.00	<p>Original software.</p> <p>Compatible with:</p> <ul style="list-style-type: none"> - FieldTool - HART communicator DXR 275 (from OS 4.6) with Rev. 1, DD 1 	50099983/06.01

10 Technical data

10.1 Quick technical data guide

10.1.1 Application

- Measuring the flow rate of liquids in closed piping systems.
- Applications in measuring, control and regulation technology for monitoring processes.

10.1.2 Function and system design

Measuring principle	The measuring system operates on the principle of transit time difference.
Measuring system	<p>The measuring system consists of one transmitter and two sensors. A number of different versions are available:</p> <ul style="list-style-type: none"> ■ Version for installation in the safe zone and for Ex Zone 2. ■ Version for installation in Ex Zone 1 (see separate Ex documentation → 130) <p><i>Transmitter</i></p> <p>Prosonic Flow 93</p> <p><i>Sensor</i></p> <ul style="list-style-type: none"> ■ Prosonic Flow P Clamp-on version (for chemical and process applications), nominal diameters DN 15 to 65 (½ to 2½") ■ Prosonic Flow P Clamp-on version (for chemical and process applications), nominal diameters DN 50 to 4000 (2 to 160") ■ Prosonic Flow W Clamp-on version (water/wastewater applications), nominal diameters DN 15 to 65 (½ to 2½") ■ Prosonic Flow W Clamp-on version (water/wastewater applications), nominal diameters DN 50 to 4000 (2 to 160") ■ Prosonic Flow W Insertion version (water/wastewater applications) nominal diameters DN 200 to 4000 (8 to 160") ■ Prosonic Flow DDU 18 (sound velocity measurement), nominal diameters DN 50 to 3000 (2 to 120") ■ Prosonic Flow DDU 19 (wall thickness measurement), <ul style="list-style-type: none"> – for wall thicknesses from 2 to 50 mm (0.08 to 2") for steel pipes – for wall thicknesses from 4 to 15 mm (0.16 to ½") for plastic pipes (only suitable for use with PTFE and PE pipes to a certain extent)

10.1.3 Input

Measured variable	Flow velocity (transit time difference proportional to flow velocity)
Measuring range	Typically $v = 0$ to 15 m/s (0 to 50 ft/s)
Operable flow range	Over 150 : 1
Input signal	<p><i>Status input (auxiliary input):</i></p> <p>$U = 3$ to 30 V DC, $R_i = 5$ kΩ, galvanically isolated.</p> <p>Configurable for: totalizer(s) reset, measured-value suppression, error-message reset.</p>

10.1.4 Output

Output signal

Current output

- Galvanically isolated
- Active/passive selectable
 - Active: 0/4 to 20 mA, $R_L < 700 \Omega$ (for HART: $R_L \geq 250 \Omega$)
 - Passive: 4 to 20 mA, max. 30 V DC, $R_i \leq 150 \Omega$
- Time constant selectable (0.01 to 100 s)
- Full scale value adjustable
- Temperature coefficient: typ. 0.005 % o.r./°C (o.r. = of reading)
- Resolution: 0.5 μ A

Pulse/frequency output

- Galvanically isolated
- Active/passive selectable
 - Active: 4 V DC, 25 mA (max. 250 mA during 20 mS), $R_L > 100 \Omega$
 - Passive: open collector, 30 V DC, 250 mA
- Time constant selectable (0.05 to 100 s)
- Frequency output
 - End frequency: 2 to 10000 Hz ($f_{\max} = 12500$ Hz)
 - End frequency for EEx ia 2 to 5000 Hz
 - On/off ratio 1:1, pulse width max. 10 s
- Pulse output
 - Pulse value and pulse polarity selectable
 - Max. pulse width adjustable (0.05 to 2000 ms)
 - As of a frequency of 1 / (2 × pulse width), the on/off ratio is 1:1

PROFIBUS DP interface

- PROFIBUS DP in accordance with EN 50170 Volume 2
- Profile version 3.0
- Data transmission rate: 9.6 kBaud to 12 MBaud
- Automatic data transmission rate recognition
- Signal encoding = NRZ Code
- Function blocks: 8 × analog input, 3 × totalizer
- Output data: volume flow channel 1 or channel 2, sound velocity channel 1 or channel 2, flow velocity channel 1 or channel 2, average volume flow, average sound velocity, average flow velocity, volume flow sum, volume flow difference, totalizer 1 to 3
- Input data: positive zero return (ON/OFF), zero point adjustment, measuring mode, totalizer control
- Bus address adjustable via miniature switches or local display (optional) at the measuring device
- Available output combination →  62

PROFIBUS PA interface

- PROFIBUS PA in accordance with EN 50170 Volume 2, IEC 61158-2 (MBP)
- Galvanically isolated
- Data transmission rate, supported baudrate: 31.25 kBit/s
- Current consumption = 11 mA
- Error current FDE (fault disconnection electronic) = 0 mA
- Signal encoding = Manchester II
- Function blocks: 8 × Analog Input (AI), 3 × Totalizer
- Output data: volume flow channel 1 or channel 2, sound velocity channel 1 or channel 2, flow velocity channel 1 or channel 2, average volume flow, average sound velocity, average flow velocity, volume flow sum, volume flow difference, totalizer 1 to 3
- Input data: positive zero return (ON/OFF), operation control, totalizer control, zero point adjustment control, display value
- Bus address can be set via DIP switch on device

FOUNDATION Fieldbus interface

- FOUNDATION Fieldbus H1, IEC 61158-2
- Galvanically isolated
- Data transmission rate, supported baudrate: 31.25 kBit/s
- Current consumption = 12 mA
- Error current FDE (fault disconnection electronic) = 0 mA
- Signal encoding = Manchester II
- Function blocks: 8 × Analog Input (AI), 1 × Discrete Output, 1 × PID
- Output data: volume flow channel 1 or channel 2, sound velocity channel 1 or channel 2, flow velocity channel 1 or channel 2, signal strength channel 1 or 2, average volume flow, average sound velocity, average flow velocity, volume flow sum, difference, volume flow, totalizer 1 to 3
- Input data: positive zero return (ON/OFF), reset totalizer, zero point adjustment control
- Link master function (LAS) is supported

Signal on alarm	<ul style="list-style-type: none"> ■ Current output → failsafe mode selectable. ■ Pulse/frequency output → failsafe mode selectable ■ Relay output → "deenergized" in the event of a fault or if the power supply fails.
-----------------	-----------------------------------------------------------------------------------------------------------------------------------------------------------------------------------------------------------------------------------------------------------

Load	→ "Output signal"
------	-------------------

Switching output	<i>Relay output</i> <ul style="list-style-type: none"> ■ NC contact or NO contact available Factory setting: relay 1 = NO contact, relay 2 = NC contact ■ Max. 30 V / 0.5 A AC; 60 V / 0.1 A DC ■ Galvanically isolated ■ Configurable for: error messages, flow direction, limit values
------------------	----------------------------------------------------------------------------------------------------------------------------------------------------------------------------------------------------------------------------------------------------------------------------------------------------------------------------------------

Low flow cutoff	Switch points for low flow are selectable
-----------------	-------------------------------------------

Galvanic isolation	All circuits for inputs, outputs, and power supply are galvanically isolated from each other.
--------------------	-----------------------------------------------------------------------------------------------

10.1.5 Power supply

Measuring unit electrical connection →  61

Connecting the connecting cable →  58

Supply voltage *Transmitter*

Current output / HART

- 85 to 260 V AC, 45 to 65 Hz
- 20 to 55 V AC, 45 to 65 Hz
- 16 to 62 V DC

Sensor

- Powered by the transmitter

Cable entry *Power supply and signal cables (inputs/outputs)*

- Cable entry M20 × 1.5 (8 to 12 mm / 0.31 to 0.47")
- Cable gland for cables, 6 to 12 mm (0.24 to 0.47")
- Thread for cable entry 1/2" NPT, G 1/2"

Connecting cable (sensor/transmitter)

Prosonic Flow P/W
Sensor DN 15 to 65 (1/2 to 2 1/2")

Cable gland for one multi core connecting cable (1 × Ø 8 mm / 0.31 in) per cable entry

- Cable gland M20 × 1.5
- Thread for cable entry 1/2" NPT, G 1/2"

Prosonic Flow P/W
Sensor DN 50 to 4000 (2 to 160")

Cable gland for two single core connecting cables (2 × Ø 4 mm / 0.16 in) per cable entry

- Cable gland M20 × 1.5
- Thread for cable entry 1/2" NPT, G 1/2"

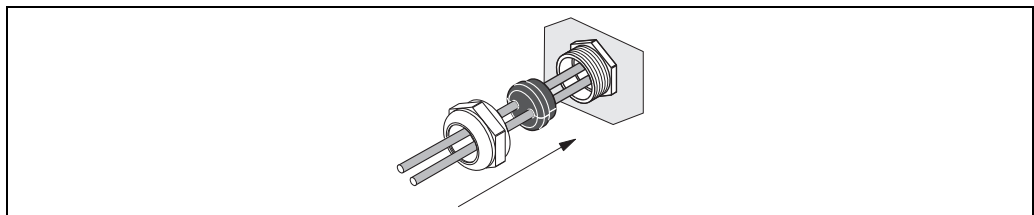



Fig. 92: Cable gland for two connecting cables (2 × Ø 4 mm / 0.16 in) per cable entry

Cable specifications Only use the connecting cables supplied by Endress+Hauser.
Different versions of the connecting cables are available →  101.

Prosonic Flow P

- Cable material:
 - Prosonic Flow 93P (DN 50 to 4000 / 2 to 160"): PVC (standard) or PTFE (for higher temperatures)
 - Prosonic Flow 93P (DN 15 to 65 / 1/2 to 2 1/2"): TPE-V
- Cable length:
 - For use in a non-hazardous zone: 5 to 60 m (16.4 to 196.8 ft)
 - For use in a hazardous zone: 5 to 30 m (16.4 to 98.4 ft)

Prosonic Flow W

- Cable material made of PVC (standard) or PTFE (for higher temperatures)
- Cable length: 5 to 60 m (16.4 to 196.8 ft)



Note!

To ensure correct measuring results, route the connecting cable well clear of electrical machines and switching elements.

Power consumption	AC: < 18 VA (incl. sensor) DC: < 10 W (incl. sensor) <i>Switch-on current:</i> ■ max. 13.5 A (< 50 ms) at 24 V DC ■ max. 3 A (< 5 ms) at 260 V AC
Power supply failure	Lasting min. 1 power cycle HistoROM/T-DAT (Prosonic Flow 93) saves measuring system data if the power supply fails.
Potential equalization	For potential equalization, no special measures are necessary.

10.1.6 Performance characteristics

Reference operating conditions	<ul style="list-style-type: none"> ■ Fluid temperature: +20 to +30 °C ■ Ambient temperature: +22 °C ± 2 K ■ Warm-up period: 30 minutes <p>Installation:</p> <ul style="list-style-type: none"> ■ Sensors and transmitter are grounded. ■ The measuring sensors are correctly installed.
Maximum measured error	<p><i>Measured error clamp-on version</i></p> <p>The measured error depends on a number of factors. A distinction is made between the measured error of the device (Prosonic Flow 93 = 0.5 % of the measured value) and an additional installation-specific measured error (typically 1.5 % of the measured value) that is independent of the device. The installation-specific measured error depends on the installation conditions on site, such as the nominal diameter, wall thickness, real pipe geometry, fluid, etc. The sum of the two measured errors is the measured error at the measuring point.</p>

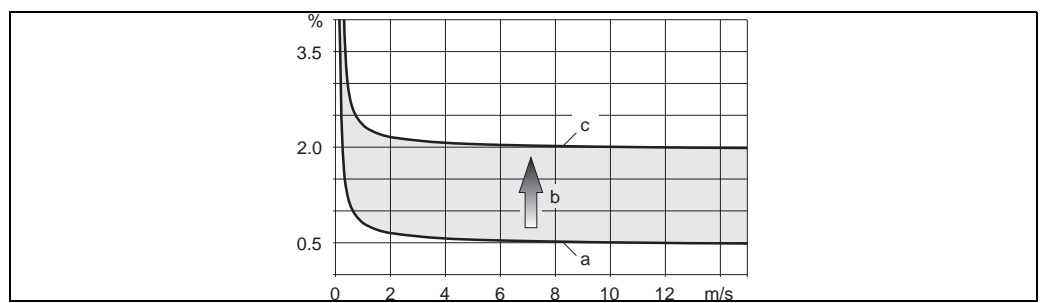

Fig. 93: Example of the measured error in a pipe with a nominal diameter DN > 200 (8")

- a Measured error of the device (0.5 % o.r. ± 3 mm/s)
- b Measured error due to installation conditions (typically 1.5 % o.r.)
- c Measured error at the measuring point: 0.5 % o.r. ± 3 mm/s + 1.5 % o.r. = 2 % o.r. ± 3 mm/s

Measured error at the measuring point

The measured error at the measuring point is made up of the measured error of the device (0.5 % o.r.) and the measured error resulting from the installation conditions on site. Given a flow velocity > 0.3 m/s (1 ft/s) and a Reynolds number > 10000, the following are typical error limits:

Sensor	Nominal diameter	Device error limits	Installation-specific error limits (typical)	→ Error limits at the measuring point (typical)
Prosonic P	DN 15 (½")	±0.5 % o.r. ± 5 mm/s	+ ±2.5 % o.r.	→ ±3 % o.r. ± 5 mm/s
	DN 25 to 200 (1 to 8")	±0.5 % o.r. ± 7.5 mm/s	+ ±1.5 % o.r.	→ ±2 % o.r. ± 7.5 mm/s
	> DN 200 (8")	±0.5 % o.r. ± 3 mm/s	+ ±1.5 % o.r.	→ ±2 % o.r. ± 3 mm/s
Prosonic W	DN 15 (½")	±0,5 % v.M. ± 5 mm/s	+ ±2.5 % v.M.	→ ±3 % v.M. ± 5 mm/s
	DN 50 to 200 (2 to 8")	±0.5 % o.r. ± 7.5 mm/s	+ ±1.5 % o.r.	→ ±2 % o.r. ± 7.5 mm/s
	> DN 200 (8")	±0.5 % o.r. ± 3 mm/s	+ ±1.5 % o.r.	→ ±2 % o.r. ± 3 mm/s

o.r. = of reading

Measurement Report

If required, the device can be supplied with a measurement report. To certify the performance of the device, a measurement is performed under reference conditions. Here, the sensors are mounted on a pipe with a nominal diameter of DN 15 (½"), DN 25 (1"), DN 40 (1½"), DN 50 (2") or DN 100 (4") respectively.

The measurement report guarantees the following error limits of the device [at a flow velocity > 0.3 m/s (1 ft/s) and a Reynolds number > 10000]:

Sensor	Nominal diameter	Guaranteed error limits of the device
Prosonic W/P	DN 15 (½"), DN 25 (1"), DN 40 (1½"), DN 50 (2")	±0.5 % o.r. ± 5 mm/s
Prosonic W/P	DN 100 (4")	±0.5 % o.r. ± 7.5 mm/s

o.r. = of reading

Measured error – Insertion system

Nominal diameter	Device error limits	+ Installation-specific error limits (typical)	→ Error limits at the measuring point (typical)
> DN 200 (8")	±0.5 o.r. ± 3 mm/s	+ ±1.5 % o.r.	→ ±2 % o.r. ± 3 mm/s

o.r. = of reading

Measurement Report

If required, the device can be supplied with a measurement report. To certify the performance of the device, a measurement is performed under reference conditions. Here, the sensors are mounted on a pipe with a nominal diameter of DN 250 (10") (single path) or DN 400 (16") (dual path).

The measurement report guarantees the following error limits of the device [at a flow velocity > 0.3 m/s (1 ft/s) and a Reynolds number > 10000]:

Sensor	Nominal diameter	Guaranteed error limits of the device
Prosonic W (Insertion)	DN 250 (10"), DN 400 (16")	±0.5 % o.r. ± 3 mm/s

o.r. = of reading

10.1.7 Operating conditions: installation

Installation instructions *Mounting location*

→  11

Orientation

→  12

Inlet and outlet run →  12

Length of connecting cable (sensor/transmitter) The connecting cable is available in the following lengths:

- 5 m (16.4 ft)
- 10 m (32.8 ft)
- 15 m (49.2 ft)
- 30 m (98.4 ft)

10.1.8 Operating conditions: environment

Ambient temperature range *Transmitter*

–20 to +60 °C (–4 to +140 °F)

Sensor P

- Standard: –40 to +80 °C (–40 to +176 °F)
- Optional: 0 to +170 °C (+32 to +338 °F)

Sensor W

- Standard: –20 to +80 °C (–4 to +176 °F)

DDU18 sensor (accessories: sound velocity measurement)

–40 to +80 °C (–40 to +176 °F)

DDU19 sensor (accessories: wall thickness measurement)

–20 to +60 °C (–4 to +140 °F)

Connecting cable (sensor/transmitter)

- Standard (TDE-V): –20 to +80 °C (–4 to +175 °F) (multi core)
- Standard (PVC): –20 to +70 °C (–4 to +158 °F) (single core)
- Optional (PTFE): –40 to +170 °C (–40 to +338 °F) (single core)



Note!

- It is permitted to insulate the sensors mounted on the pipes.
- Mount the transmitter in a shady location and avoid direct sunlight, particularly in warm climatic regions.

Storage temperature The storage temperature corresponds to the ambient temperature range.

Degree of protection	<p><i>Transmitter</i></p> <p>IP 67 (NEMA 4X)</p> <p><i>Sensor P</i></p> <p>IP 68 (NEMA 6P)</p> <p><i>Sensor W</i></p> <p>IP 67 (NEMA 4X) optional: IP 68 (NEMA 6P)</p> <p><i>DDU18 sensor (accessories: sound velocity measurement)</i></p> <p>IP 68 (NEMA 6P)</p> <p><i>DDU19 sensor (accessories: wall thickness measurement)</i></p> <p>IP 67 (NEMA 4X)</p>
----------------------	----------------------------------------------------------------------------------------------------------------------------------------------------------------------------------------------------------------------------------------------------------------------------------------------------------------------------------------------------------------

Shock resistance	In according with IEC 68-2-31
------------------	-------------------------------

Vibration resistance	Acceleration up 1g, 10 to 150Hz, following IEC 68-2-6
----------------------	-------------------------------------------------------

Electromagnetic compatibility (EMC)	Electromagnetic compatibility (EMC requirements) according to IEC/EN 61326 "Emission to class A requirements" and NAMUR Recommendation NE 21/43.
-------------------------------------	--------------------------------------------------------------------------------------------------------------------------------------------------



10.1.9 Operating conditions: process

Medium temperature range	<p><i>Prosonic Flow P sensor</i></p> <p>Prosonic Flow P (DN 15 to 65 / ½ to 2½")</p> <ul style="list-style-type: none"> ■ Standard: -40 to +100 °C (-40 to +212 °F) ■ Optional: -40 to +150 °C (-40 to +302 °F) <p>Prosonic Flow P (DN 50 to 4000 / 2 to 160")</p> <ul style="list-style-type: none"> ■ Standard: -40 to +80 °C (-40 to +176 °F) ■ Optional: 0 to +170 °C (+32 to +338 °F) <p><i>Prosonic Flow W sensor</i></p> <ul style="list-style-type: none"> ■ Clamp-on: -20 to +80 °C (-4 to +176 °F) ■ Insertion version: -40 to +80 °C (-40 to +176 °F) <p><i>Sensor (accessories)</i></p> <ul style="list-style-type: none"> ■ Prosonic Flow DDU18 (sound velocity measurement): -40 to +80 °C (-40 to +176 °F) ■ Prosonic Flow DDU19 (wall thickness measurement): -0 to +60 °C (-4 to +140 °F)
--------------------------	------------------------------------------------------------------------------------------------------------------------------------------------------------------------------------------------------------------------------------------------------------------------------------------------------------------------------------------------------------------------------------------------------------------------------------------------------------------------------------------------------------------------------------------------------------------------------------------------------------------------------------------------------------------------------------------------------------------------------------------------------------------------------------------------------------------------------------------------------------------------------------------------------------

Medium pressure range (nominal pressure)	Perfect measurement requires that the static fluid pressure is higher than vapor pressure.
------------------------------------------	--------------------------------------------------------------------------------------------

Pressure loss	There is no pressure loss.
---------------	----------------------------

10.1.10 Mechanical construction

Design / dimensions	<p>The dimensions and lengths of the sensor and transmitter are provided in the separate "Technical Information" document on the device in question. This can be downloaded as a PDF file from www.endress.com.</p> <p>A list of the "Technical Information" documents available is provided on →  130.</p>
Weight	<p><i>Transmitter</i></p> <ul style="list-style-type: none"> ■ Wall-mount housing: 6.0 kg (13.2 lbs) ■ Field housing: 6.7 kg (14.8 lbs) <p><i>Prosonic Flow P sensor</i></p> <ul style="list-style-type: none"> ■ Prosonic Flow P DN 15 to 65 (½ to 2½") (incl. mounting material): 1.2 kg (2.65 lbs) ■ Prosonic Flow P DN 50 to 4000 (2 to 160") (incl. mounting material): 2.8 kg (6.2 lbs) <p><i>Prosonic Flow W sensor</i></p> <ul style="list-style-type: none"> ■ Prosonic Flow W Clamp-on DN 15 to 65 (½ to 2½") (incl. mounting material): 1.2 kg (2.65 lbs) ■ Prosonic Flow W Clamp-on (incl. mounting material): 2.8 kg (6.2 lbs) ■ Prosonic Flow W Insertion version (incl. mounting material): <ul style="list-style-type: none"> – Single path version: 4.5 kg (9.92 lbs) – Dual path version: 12 kg (26.5 lbs) <p><i>Sensor (accessories)</i></p> <ul style="list-style-type: none"> ■ Prosonic Flow DDU18 (incl. mounting material): 2.4 kg (5.3 lbs) ■ Prosonic Flow DDU19 (incl. mounting material): 1.5 kg (3.3 lbs) <p> Note! Weight information without packaging material.</p>
Materials	<p><i>Transmitter</i></p> <ul style="list-style-type: none"> ■ Wall-mounted housing: powder-coated die-cast aluminum ■ Field housing: powder-coated die-cast aluminum <p><i>Prosonic P sensor</i></p> <ul style="list-style-type: none"> ■ Sensor holder: stainless steel 1.4301 (AISI 304) ■ Sensor housing: stainless steel 1.4301 (AISI 304) ■ Strapping bands/bracket: stainless steel 1.4301 (AISI 304) ■ Sensor contact surfaces: chemically stable plastic <p><i>Prosonic W sensor</i></p> <p>Prosonic Flow W clamp-on version</p> <ul style="list-style-type: none"> ■ Sensor holder: stainless steel 1.4308/CF-8 ■ Sensor housing: stainless steel 1.4301 (AISI 304) ■ Strapping bands/bracket: textile or stainless steel 1.4301 (AISI 304) ■ Sensor contact surfaces: chemically stable plastic <p>Prosonic Flow W Insertion version</p> <ul style="list-style-type: none"> ■ Sensor holder: stainless steel 1.4308/CF-8 ■ Sensor housing: stainless steel 1.4301 (AISI 304) ■ Weld-in parts: stainless steel 1.4301 (AISI 304) ■ Sensor contact surfaces: chemically stable plastic

Sensor (accessories)

Prosonic Flow DDU18; Prosonic Flow P DDU19

- Sensor holder: stainless steel 1.4308/CF-8
- Sensor housing: stainless steel 1.4301 (AISI 304)
- Strapping bands/bracket: textile or stainless steel 1.4301 (AISI 304)
- Sensor contact surfaces: chemically stable plastic

Connecting cable (sensor/transmitter), Prosonic Flow 93P

Prosonic Flow 93P (DN 15 to 65)

- TPE-V connecting cable
 - Cable sheath: TPE-V
 - Cable connector: stainless steel 1.40301

Prosonic Flow 93P (DN 50 to 4000)

- PVC connecting cable
 - Cable sheath: PVC
 - Cable connector: nicked brass 2.0401
- PTFE connecting cable
 - Cable sheath: PTFE
 - Cable connector: stainless steel 1.4301

Connecting cable (sensor/transmitter), Prosonic Flow 93W

Prosonic Flow 93W (DN 15 to 65)

- TPE-V connecting cable
 - Cable sheath: TPE-V
 - Cable connector: stainless steel 1.40301
- PVC connecting cable
 - Cable sheath: PVC
 - Cable connector: nicked brass 2.0401
- PTFE connecting cable
 - Cable sheath: PTFE
 - Cable connector: stainless steel 1.4301

10.1.11 Human interface

Display elements	<ul style="list-style-type: none"> ■ Liquid crystal display: illuminated, four lines each with 16 characters ■ Custom configuration for presenting different measured values and status variables ■ 3 totalizers.
Operating elements	<ul style="list-style-type: none"> ■ Local operation with three optical keys ■ Application specific Quick Setup menus for straightforward commissioning.
Language groups	<p>Language groups available for operation in different countries:</p> <ul style="list-style-type: none"> ■ Western Europe and America (WEA): English, German, Spanish, Italian, French, Dutch and Portuguese ■ Eastern Europe/Scandinavia (EES): English, Russian, Polish, Norwegian, Finnish, Swedish and Czech. ■ South and Eastern Asia (SEA): English, Japanese, Indonesian ■ China (CN): English, Chinese <p> Note! You can change the language group via the operating program "FieldCare".</p>
Remote operation	Operation via HART, PROFIBUS DP/PA, FOUNDATION Fieldbus and FieldCare

10.1.12 Certificates and approvals

Ex approval	Information on the currently available Ex-rated versions (ATEX, FM, CSA, IECEx, NEPSI, etc.) can be supplied by your Endress+Hauser Sales Center on request. All information relevant to explosion protection is available in separate documents that you can order as necessary.
CE mark	The measuring system is in conformity with the statutory requirements of the EC Directives. Endress+Hauser confirms successful testing of the device by affixing to it the CE mark.
C-Tick mark	The measuring system is in conformity with the EMC requirements of the "Australian Communications and Media Authority" (ACMA).
Other standards and guidelines	<ul style="list-style-type: none"> ■ EN 60529 Degrees of protection provided by enclosures (IP code). ■ EN 61010-1 Safety requirements for electrical equipment for measurement, control and laboratory use. ■ IEC/EN 61326 "Emission in accordance with Class A requirements". Electromagnetic compatibility (EMC requirements). ■ ANSI/ISA-S82.01 Safety Standard for Electrical and Electronic Test, Measuring, Controlling and Related Equipment – General Requirements. Pollution Degree 2, Installation Category II. ■ CAN/CSA-C22.2 No. 1010.1-92 Safety Requirements for Electrical Equipment for Measurement and Control and Laboratory Use. Pollution Degree 2, Installation Category II. ■ NAMUR NE 21 Electromagnetic compatibility (EMC) of industrial process and laboratory control equipment. ■ NAMUR NE 43 Standardization of the signal level for the breakdown information of digital transmitters with analog output signal. ■ NAMUR NE 53 Software of field devices and signal-processing devices with digital electronics.

10.1.13 Accessories

Various accessories, which can be ordered separately from Endress+Hauser, are available for the transmitter and the sensor →  101.
Your Endress+Hauser service organization can provide detailed information on the order codes in question.

10.1.14 Ordering information

The Endress+Hauser service organization can provide detailed ordering information and information on the order codes on request.

10.1.15 Documentation

- Flow measurement (FA005D)
- Technical Information for Promass Flow 93P (TI083D)
- Technical Information for Prosonic Flow 93W (TI084D)
- Description of Device Functions for Prosonic Flow 93 (BA071D)
- Supplementary documentation on Ex-ratings: ATEX, FM, CSA, IEC, NEPSI

Index

A

Accessories	101
Advanced diagnostics (add-on)	93
Applications	5
Applicator (selection and configuration software)	104
Approvals	10

C

CE mark (Declaration of Conformity)	10
Certificates	10
Cleaning	
Exterior cleaning	100
Code entry (function matrix)	70
Commissioning	
Configuring the relay contact (NC/NO contact)	98
Functions for advanced diagnostics	93
One current output	97
Quick Setup "Pulsating Flow"	88
Two current outputs	98
Commubox FXA 195 (electrical connection)	103
Commubox FXA195 (electrical connection)	63
Communication	72
Connection	
See Electrical connection	
Coupling fluid	100
C-Tick mark	10
Current output, one	
Active/passive configuration	97
Current outputs, two	
Active/passive configuration	98

D

Data back-up	95
Declaration of Conformity (CE mark)	10
Designated use	5
Device description files	74
Device designation	7
Device functions	
See "Description of Device Functions" manual	
See Function descriptions	
Diagnostic functions, advanced (add-on)	93
Display	
Display and operating elements	66
Disposal	117

E

Electrical connection	
Commubox FXA195	63
HART handheld terminal	63
Potential equalization	64
Transmitter terminal assignment	62
Error messages	
Confirming error messages	71
Process error (application error)	110
Error types (system and process errors)	71
Ex approval	130
Exterior cleaning	100

F

Failsafe mode of inputs/outputs	112
F-Chip	99
FieldCare	73, 104
Fieldcheck (tester and simulator)	104
Function check	83
Function description	
See "Description of Device Functions" manual	
Function matrix	
Brief operating instructions	69
Fuse, replacing	117
FXA193	104
FXA195	103

H

HART	
Command No.	75
Device status, error messages	80
Electrical connection	63
Error messages	75
Handheld terminal	73
Switching write protection on/off	96
Hazardous substances	6
HOME position (display operating mode)	66

I

Incoming acceptance	11
Input signal	119
Installation	
Panel mounting, wall-mount housing	56
Pipe mounting, wall-mount housing	56
Wall-mount housing	55
Installation conditions	
Dimensions	11
Inlet and outlet run	12
Mounting location	11
Installation distances	
Prosonic Flow P	16
Prosonic Flow W	16
Installation distances (determining values)	
Applicator	28
FieldCare	22
Local operation	17
Installing/removing the W sensor (Insertion version)	116
IP 67, IP 68	64

L

Language groups	129
-----------------------	-----

M

Materials	127
Measuring sensor installation	
Installation distances	16
Mechanical preparation	30
Preparatory steps	16
Prosonic Flow DDU 18	53
Prosonic Flow DDU 19	54

- Prosonic Flow P
 - DN 15 to 65 35
 - DN 50 to 4000, one traverse 37
 - DN 50 to 4000, two traverses 39
- Prosonic Flow W
 - Clamp On, one traverse 41
 - Clamp On, two traverses 43
 - Insertion, dual-path 49
 - Insertion, general information 45
 - Insertion, single-path 46
 - selection and arrangement 13
- Measuring system 7
- Mechanical preparation
 - Prosonic Flow P (DN 15 to 65)
 - Retainer with strapping bands 31
 - Retainer with U-shaped screws 30
 - Strapping bands (large nominal diameters) 33
 - Strapping bands (medium nominal diameters) 32
 - Welded bolts 34
- N**
 - Nameplate
 - Connections 9
 - Sensor 8
 - Transmitter 7
 - NC contact (relay contact) 98
 - NO contact (relay contact) 98
- O**
 - Operable flow range 119
 - Operation
 - Device description files 74
 - Display and operating elements 66
 - FieldCare 73
 - Function matrix 69
 - HART handheld terminal 73
 - Operational safety 5
 - Order code
 - Accessories 101
 - Transmitter 7–9
 - Ordering information 130
- P**
 - Position sensor 16
 - Post-installation check (checklist) 57
 - Potential equalization 64
 - Process error
 - Definition 71
 - Messages 110
 - Without messages 111
 - Programming mode
 - Disabling 70
 - Enabling 70
 - Pulsating Flow 88
 - Pump types, pulsating flow 88
- Q**
 - Quick Setup
 - "Comissioning" 85
 - "Pulsating Flow" 88
- "Sensor Installation" 84
- R**
 - Registered trademarks 10
 - Relay output
 - Configuring the relay contact (NC/NO contact) 98
 - Technical data 121
 - Remote operation 129
 - Repair 6
 - Returning devices 6
- S**
 - Safety icons 6
 - Safety instructions 5
 - Sensor distance 16, 49
 - Serial number 7–9
 - Service interface FXA193 104
 - Shock resistance 126
 - Software
 - Amplifier display 83
 - Sound velocity measuring sensors DDU 18
 - Installation 53–54
 - Standards, guidelines 130
 - Status input
 - Technical data 119
 - Storage 11
 - Supplementary Ex documentation 5
 - System error
 - Definition 71
- T**
 - T-DAT 95
 - Data storage 95
 - Definition 99
 - Temperature ranges
 - Storage temperature 125
 - Transmitter
 - Electrical connection 61
 - Installing the wall-mount transmitter housing 55
 - Traverse 13
 - Troubleshooting and remedy 105
 - Two-channel measurement 14
 - Two-channel operation 14
 - Two-path measurement 15
- V**
 - Vibration resistance 126
 - Vibrations, shock and vibration resistance 126
- W**
 - Wall-mount housing
 - Installation 55
 - Panel mounting 56
 - Pipe mounting 56
 - Wire length 16
 - Wiring
 - See Electrical connection
- Z**
 - Zero point adjustment 91

Declaration of Hazardous Material and De-Contamination Erklärung zur Kontamination und Reinigung

RA No.

Please reference the Return Authorization Number (RA#), obtained from Endress+Hauser, on all paperwork and mark the RA# clearly on the outside of the box. If this procedure is not followed, it may result in the refusal of the package at our facility.
Bitte geben Sie die von E+H mitgeteilte Rücklieferungsnummer (RA#) auf allen Lieferpapieren an und vermerken Sie diese auch außen auf der Verpackung. Nichtbeachtung dieser Anweisung führt zur Ablehnung ihrer Lieferung.

Because of legal regulations and for the safety of our employees and operating equipment, we need the "Declaration of Hazardous Material and De-Contamination", with your signature, before your order can be handled. Please make absolutely sure to attach it to the outside of the packaging.

Aufgrund der gesetzlichen Vorschriften und zum Schutz unserer Mitarbeiter und Betriebseinrichtungen, benötigen wir die unterschriebene "Erklärung zur Kontamination und Reinigung", bevor Ihr Auftrag bearbeitet werden kann. Bringen Sie diese unbedingt außen an der Verpackung an.

Type of instrument / sensor

Geräte-/Sensortyp _____

Serial number

Seriennummer _____

Used as SIL device in a Safety Instrumented System / Einsatz als SIL Gerät in Schutzeinrichtungen

Process data / Prozessdaten

Temperature / Temperatur _____ [°F] _____ [°C]

Pressure / Druck _____ [psi] _____ [Pa]

Conductivity / Leitfähigkeit _____ [µS/cm]

Viscosity / Viskosität _____ [cp] _____ [mm²/s]

Medium and warnings

Warnhinweise zum Medium



	Medium / concentration Medium / Konzentration	Identification CAS No.	flammable entzündlich	toxic giftig	corrosive ätzend	harmful/ irritant gesundheitsschädlich/ reizend	other * sonstiges*	harmless unbedenklich
Process medium Medium im Prozess								
Medium for process cleaning Medium zur Prozessreinigung								
Returned part cleaned with Medium zur Endreinigung								

* explosive; oxidising; dangerous for the environment; biological risk; radioactive

* explosiv; brandfördernd; umweltgefährlich; biogefährlich; radioaktiv

Please tick should one of the above be applicable, include safety data sheet and, if necessary, special handling instructions.

Zutreffendes ankreuzen; trifft einer der Warnhinweise zu, Sicherheitsdatenblatt und ggf. spezielle Handhabungsvorschriften beilegen.

Description of failure / Fehlerbeschreibung _____

Company data / Angaben zum Absender

Company / Firma _____	Phone number of contact person / Telefon-Nr. Ansprechpartner: _____
Address / Adresse _____	Fax / E-Mail _____
_____	Your order No. / Ihre Auftragsnr. _____

"We hereby certify that this declaration is filled out truthfully and completely to the best of our knowledge. We further certify that the returned parts have been carefully cleaned. To the best of our knowledge they are free of any residues in dangerous quantities."

"Wir bestätigen, die vorliegende Erklärung nach unserem besten Wissen wahrheitsgetreu und vollständig ausgefüllt zu haben. Wir bestätigen weiter, dass die zurückgesandten Teile sorgfältig gereinigt wurden und nach unserem besten Wissen frei von Rückständen in gefährlicher Menge sind."

(place, date / Ort, Datum)

Name, dept./Abt. (please print / bitte Druckschrift)

Signature / Unterschrift

www.endress.com/worldwide

Endress + Hauser 
People for Process Automation
