

# C-PT Ultrasonic Flow Transducer

## Installation Guide



# C-PT Ultrasonic Flow Transducer

## Installation Guide

916-074 Rev. B  
July 2021

[panametrics.com](http://panametrics.com)

Copyright 2021 Baker Hughes company.

This material contains one or more registered trademarks of Baker Hughes Company and its subsidiaries in one or more countries. All third-party product and company names are trademarks of their respective holders.

[no content intended for this page]

---

## Information Paragraphs

**Note:** These paragraphs provide information that provides a deeper understanding of the situation, but is not essential to the proper completion of the instructions.

**IMPORTANT:** These paragraphs provide information that emphasizes instructions that are essential to proper setup of the equipment. Failure to follow these instructions carefully may cause unreliable performance.



**CAUTION!** This symbol indicates a risk of potential minor personal injury and/or severe damage to the equipment, unless these instructions are followed carefully.



**WARNING!** This symbol indicates a risk of potential serious personal injury, unless these instructions are followed carefully.

## Safety Issues



**WARNING!** It is the responsibility of the user to make sure all local, county, state and national codes, regulations, rules and laws related to safety and safe operating conditions are met for each installation.



**WARNING!** For installations in potentially hazardous areas, be sure to read the *Certification and Safety Statements* document at the end of this manual before beginning the installation.

## Auxiliary Equipment

### Local Safety Standards

The user must make sure that he operates all auxiliary equipment in accordance with local codes, standards, regulations, or laws applicable to safety.

### Working Area



**WARNING!** Auxiliary equipment may have both manual and automatic modes of operation. As equipment can move suddenly and without warning, do not enter the work cell of this equipment during automatic operation, and do not enter the work envelope of this equipment during manual operation. If you do, serious injury can result.



**WARNING!** Make sure that power to the auxiliary equipment is turned OFF and locked out before you perform maintenance procedures on the equipment.

---

## Qualification of Personnel

Make sure that all personnel have manufacturer-approved training applicable to the auxiliary equipment.

## Personal Safety Equipment

Make sure that operators and maintenance personnel have all safety equipment applicable to the auxiliary equipment. Examples include safety glasses, protective headgear, safety shoes, etc.

## Unauthorized Operation

Make sure that unauthorized personnel cannot gain access to the operation of the equipment.

## Environmental Compliance

### Waste Electrical and Electronic Equipment (WEEE) Directive

GE Measurement & Control is an active participant in Europe's *Waste Electrical and Electronic Equipment (WEEE)* take-back initiative, directive 2012/19/EU.

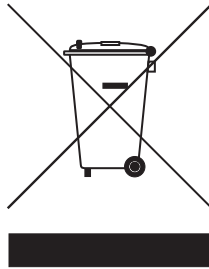

The equipment that you bought has required the extraction and use of natural resources for its production. It may contain hazardous substances that could impact health and the environment.

In order to avoid the dissemination of those substances in our environment and to diminish the pressure on the natural resources, we encourage you to use the appropriate take-back systems. Those systems will reuse or recycle most of the materials of your end life equipment in a sound way.

The crossed-out wheeled bin symbol invites you to use those systems.

If you need more information on the collection, reuse and recycling systems, please contact your local or regional waste administration.

Visit [www.bakerhughesds.com/health-safetyand-environment-hse](http://www.bakerhughesds.com/health-safetyand-environment-hse) for take-back instructions and more information about this initiative.

1 Introduction .....1

2 Transducer Construction .....1

3 Measurement Methods .....1

    3.1 Transit-Time Method .....2

    3.2 TransFlection Method .....2

4 Couplants .....3

5 Installing C-PT Transducers for the Transit-time Method .....4

    5.1 Determining the Number of Traverses .....4

    5.2 Installing the Universal Clamping Fixture - UCF .....6

        5.2.1 Verifying Fixture Length .....6

        5.2.2 Identifying the UCF Components .....6

        5.2.3 The Double-Traversal Method -UCF.....8

        5.2.4 The Single-Traversal Method - UCF .....11

        5.2.5 Mounting Transducers into the UCF .....16

    5.3 Installing the General Clamping Fixture - GCF .....18

        5.3.1 The Double-Traversal Method - GCF.....19

        5.3.2 The Single-Traversal Method - GCF .....21

        5.3.3 Mounting Transducers into the GCF .....26

    5.4 Installing the Magnetic Clamping Fixture - MCF.....29

        5.4.1 Identifying the MCF Components .....29

        5.4.2 The Double-Traversal Method - MCF.....30

        5.4.3 The Single-Traversal Method - MCF .....32

        5.4.4 Mounting Transducers into the MCF .....35

6 Installing C-PT Transducers for the TransFlection Method .....38

    6.1 Mounting the TransFlection Mode Clamping Fixture - TMCF .....38

        6.1.1 Mounting the TMCF in a <180o Configuration .....39

        6.1.2 Mounting the TMCF in a 180o Configuration .....42

    6.2 Mounting the Transducers into the TransFlection Mode Clamping Fixture - TMCF.....45

7 Maintaining the C-PT Transducers .....48

8 Specifications .....49

    8.1 General Specifications .....49

    8.2 Hazardous Area Certifications .....50





## 1 Introduction

The *C-PT ultrasonic flow transducer* is used exclusively with the Panametrics line of ultrasonic flowmeters. These transducers measure the flow rate of sonically-conductive liquids through pipes having diameters between 2 in. (5 cm) and over 300 in. (760 cm). Such measurements are typically independent of the pipe material.

This document provides the following instructions on installing and maintaining C-PT transducers:

- Transducer Construction - below
- Measurement Methods - page 1
- Couplants - page 3
- Installing Transducers for the Transit-Time Method - page 4
- Installing Transducers for the TransFlection Method - page 38
- Maintaining Transducers - page 48
- Specifications - page 49

## 2 Transducer Construction

Each C-PT transducer assembly consists of the following components (see Figure 1 on page 1):

- a metallic cover with 1/2" NPT male thread for attaching a junction box
- a transducer that consists of a piezo electric element mounted on a wedge and wired to the BNC connector
- a BNC style connector for use in connecting the transducer to the flowmeter.

The internal cavity of the assembly, including the transducer cover and the transducer head, is filled with a damping compound. The C-PT is available in the following process temperature ranges:

- Normal: -4 to 122°F (-20 to 50°C)
- Medium: -4 to 293°F (-20 to 145°C)
- High: -4 to 363°F (-20 to 184°C)\*

\*This temperature is for ATEX certified designs. Consult factory for higher temperatures.

**IMPORTANT:** Transducer assembly C-PT-H must be mounted in such a way that it is protected against impact.

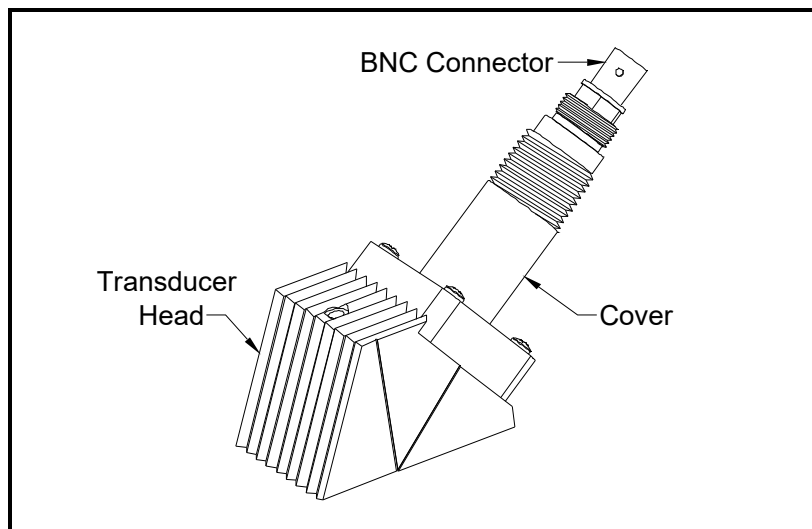

Figure 1: General C-PT Transducer Assembly

## 3 Measurement Methods

---

C-PT transducers can be installed using a number of configurations and clamping fixtures; however, how this is done largely depends on the flowmeter's measurement mode. Although many of Panametrics flowmeters have one mode called Transit-time, some Panametrics flowmeters have an additional measurement mode called TransFlection. Although both methods use time measurement, the method in which time is measured is different.

### 3.1 Transit-Time Method

When in Transit-time mode, the flowmeter transmits ultrasonic pulses through a moving liquid. The pulses that travel in the same direction as the fluid flow (downstream), travel slightly faster than the pulses that travel against the flow (upstream). The flowmeter uses various digital signal-processing techniques, including cross-correlation, to determine transit times, and then uses these times to calculate flow velocity.

### 3.2 TransFlection Method

To measure flow, one transducer transmits a group of pulses (typically 16 pulses) at regular intervals (approximately 5,000 to 10,000 transmissions/sec). The ultrasonic pulses travel through the liquid, reflect off scatterers (i.e. bubbles, particulates) and the signal is then received by the second transducer.

In essence, these ultrasonic signals are "pictures" taken continuously at the same location in the pipe. The flowmeter compares these pictures to one another as each picture is received. By comparing (averaging) these pictures, the flowmeter is able to eliminate stationary objects by subtracting signals that do not appear to move in all or most of the pictures. The flowmeter measures the time difference between the remaining "moving" objects on each successive picture. The time difference is called  $T_m$  and is used to calculate flow.

---

## 4 Couplants

Panametrics supplies an ultrasonic couplant for your C-PT installation. The purpose of the couplant is to provide reliable transmission of ultrasound between two adjacent solid surfaces. Generally speaking, couplants perform this task by excluding air from between the adjacent surfaces. Accordingly, the C-PT transducers should be pressed tightly against the pipe, using hand pressure on the set screw to squeeze the couplant to as thin a film as practical for the given pipe surface.

The most commonly used couplants in ultrasonic testing are ordinarily satisfactory for any short-term clamp-on flowmeter application. These couplants include, in general order of preference: gels, grease, propylene glycol, oil, glycerine, and water. Long-term couplants include grease, epoxy adhesive, and solid rubber-like sheet couplant.

Panametrics provides couplants for both permanent and temporary use as well as for high- and low-temperature applications. For long-term installations, make sure the couplant does not dry or run out.

Standard couplants supplied from Panametrics are listed in Table 1.

**Table 1: Couplants**

Part No.	Type	Temp. Range	Use
CPL-1	Standard	-40 to 149°F (-40 to 65°C)	Semi-Permanent
CPL-2	High/Low Temperature	-256 to 500°F (-160 to 260°C)	Semi-Permanent
CPL-3	Portable	-4 to 140°F (-20 to 60°C)	Temporary
CPL-4	Special	As Required	* Difficult Applications
CPL-7	Epoxy	14 to 122°F (-10 to 50°C)	Permanent
CPL-8	Solid Sheet	-40 to 446°F (-40 to 130°C)	Permanent

\* Installations involving hotter or colder temperatures than listed above, may require special couplants. Consult Panametrics for these applications.

---

## 5 Installing C-PT Transducers for the Transit-time Method

Installing the C-PT transducers consists of determining the number of traverses, mounting the clamping fixture to the pipe and then mounting the transducers into the clamping fixture.

Use the sections that follow to properly install the fixture and transducers.

**CAUTION!** A flowmeter's accuracy and performance depends on the location, spacing, and alignment of the transducers. The transducer spacing is unique to your installation.

### 5.1 Determining the Number of Traverses

The first step of installation is determining the number of traverses. The transducers can be mounted using one of two methods (see Figure 2 on page 5):

- Double-traverse method ("V" method) - transducers are mounted on the same side of the pipe and the ultrasonic signal is bounced from one transducer to the other, off the opposite pipe wall.
- Single-traverse method ("Z" method) - transducers are mounted diagonally across from each other. The ultrasonic signal is transmitted directly from one transducer to the other, across the pipe.

For pipe diameters from 4 to 20 in., always try the double-traverse method because it is easier to configure and yields greater accuracy. However, if the pipe has poor inside surface conditions or the fluid is highly attenuating, you may not be able to obtain a reliable signal. Therefore, you should use the single-traverse method. Typically, you should try the single-traverse method for pipe diameters greater than 20 in. Spacing of the transducers is calculated by the electronics after all the installation parameters have been programmed into the flowmeter.

- Universal clamping fixture - page 6
- General clamping fixture (permanent installation) - page 18
- Magnetic clamping fixture - page 29

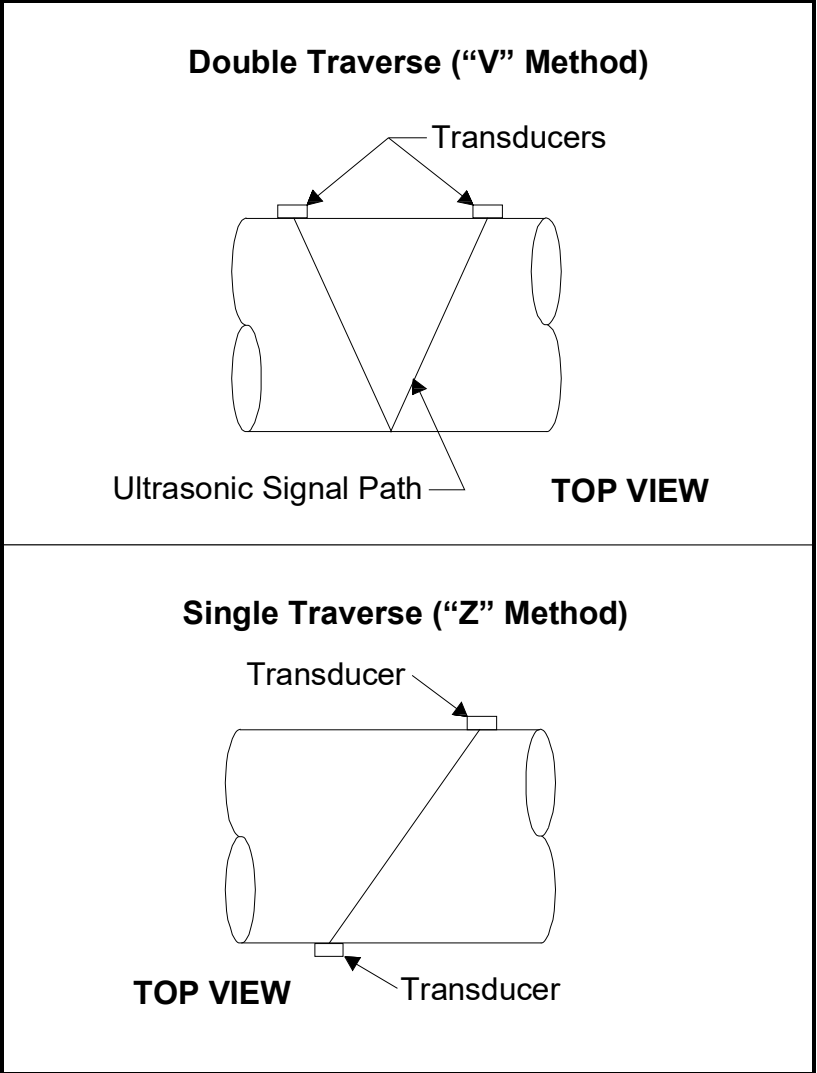

Figure 2: Double- and Single-Traverse Installations

---

## 5.2 Installing the Universal Clamping Fixture - UCF

The Universal Clamping Fixture (UCF) acts as a spacing device and a transducer holder. The UCF is available in two lengths and consists of a number of components. Before you begin installation, you should verify your fixture is the correct length and familiarize yourself with the fixture components.

### 5.2.1 Verifying Fixture Length

Make sure you note the following restrictions for your clamping fixture. The UCF is available in two lengths, 12 in. and 24 in. (~30.5 cm and ~61 cm). Each size fixture can be installed for a single- or double-traverse method. However, depending on the method used, there are pipe size restrictions that are outlined in Table 2.

**Table 2: UCF Pipe Sizes**

Clamping Fixture Length	Single-Traverse Pipe Diameter	Double-Traverse Pipe Diameter
12-in. (30.5 cm)	2 to 24 in. (5 to 61 cm)	2 to 12 in. (5 to 30.5 cm)
24-in. (61 cm)	24 to 48 in. (61 to 122 cm)	12 to 24 in. (30.5 to 61 cm)

**Note:** *The mounting chain provided is best suited for your application.*

### 5.2.2 Identifying the UCF Components

The UCF has two adjustable short blocks that are used for the double-traverse method. Two slide tracks connect the blocks. A ruler attached to one of the tracks helps set the transducer spacing. For single-traverse methods, a long block is also used.

The blocks are used to hold the transducers in position for accurate measurement. The UCF is chained or strapped around the pipe. The blocks are positioned using the spacing dimension calculated by the flowmeter. Then the transducers are mounted into the blocks. Figure 3 on page 7 shows the short and long blocks.

The transducer installation consists of mounting the UCF to the pipe and then mounting the transducers into the fixture. Refer to the appropriate section that follows for instructions:

- Double-traverse Method - page 8
- Single-traverse Method - page 11

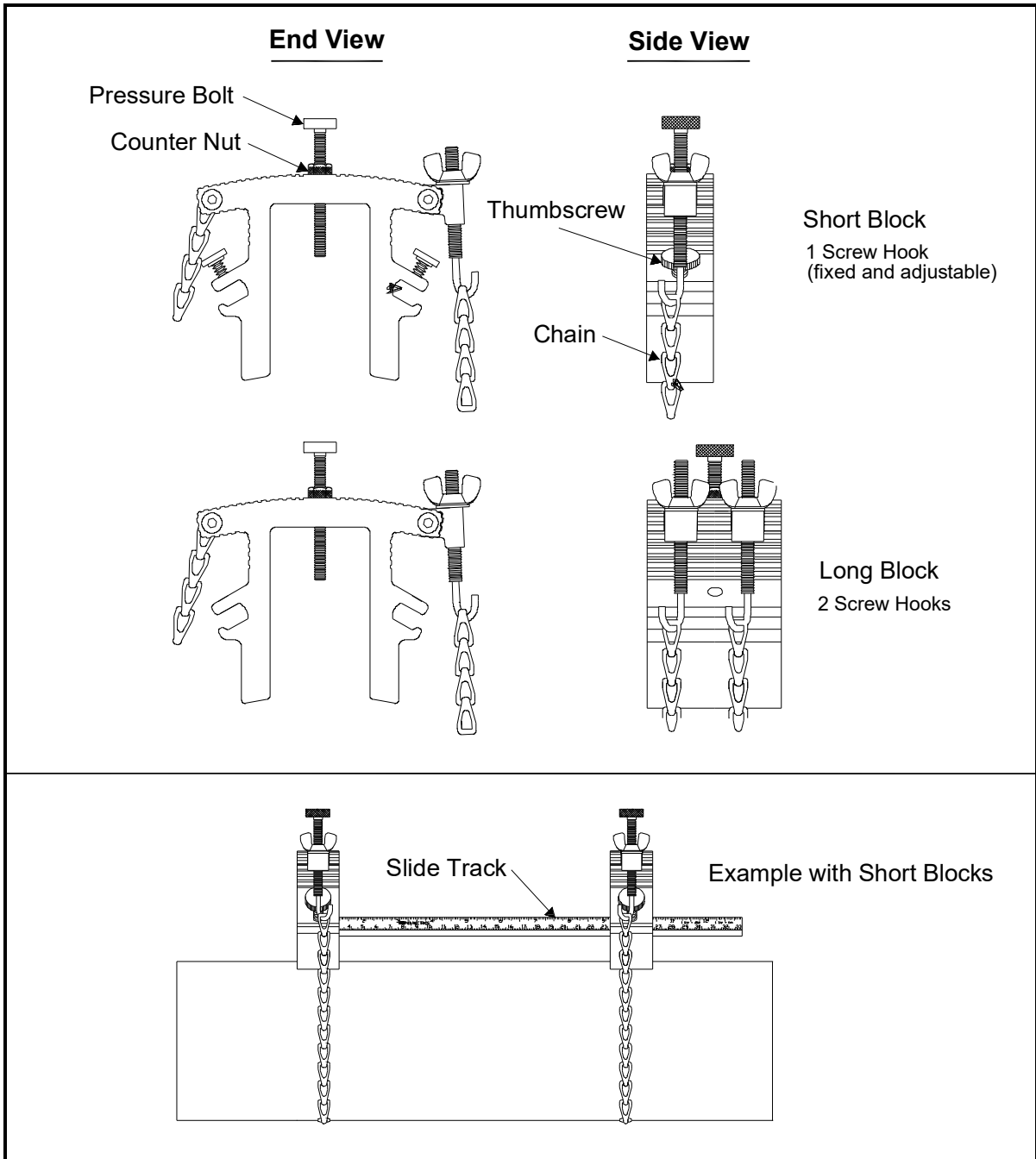

Figure 3: Components of the UCF

### 5.2.3 The Double-Traverse Method -UCF

**Note:** The instructions in this section can also be used for a multiple-traverse method. However, you must use an **EVEN** number of traverses. The distance the signal travels from one side of the pipe wall to the opposite side of the pipe wall is considered one traverse. For more than two traverses, consult the GE factory.

There are three advantages to using the double-traverse method:

- Accuracy is improved because the signal is in the fluid longer than with a single-traverse.
- This configuration can reduce some effect of an underdeveloped flow profile.
- If there is enough pipe length available, the double-traverse fixture is easier to install.

The procedure for mounting the UCF involves setting the transducer spacing and fastening the fixture on the pipe. Please note you will only need the short block assembly for a double-traverse installation; the long block is not used.

1. Obtain the transducer spacing dimension  $S$ , as described in the programming section of the *Startup Guide*.
2. Be sure the location you have chosen for the installation has at least 10 pipe diameters of straight, undisturbed flow upstream and 5 pipe diameters downstream of the measurement point.
3. Prepare the pipe where you intend to place the clamping fixture by making sure it is clean and free of loose material. Sanding, though usually not required, may be necessary to take off any high spots. When sanding, be careful to preserve the original curvature of the pipe.
4. Using the attached ruler, move the blocks so they are a distance  $S$  from each other. Use the pressure bolt or the ends of the blocks as reference points.

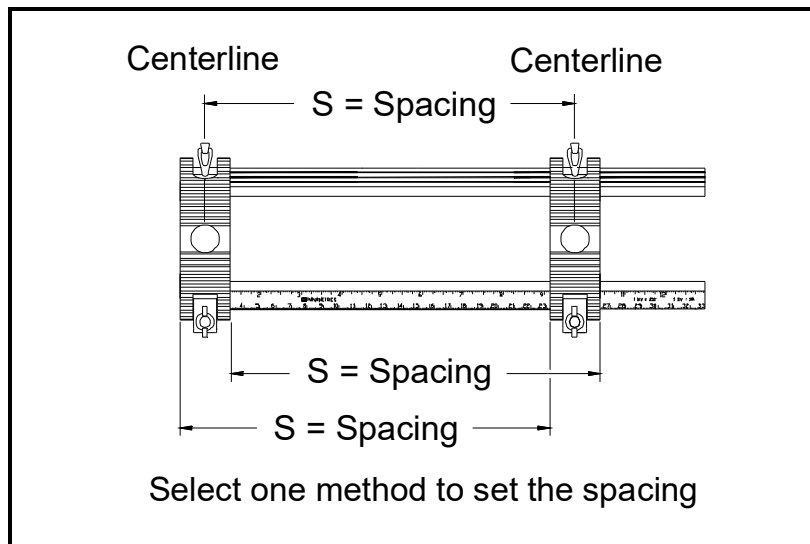

5. Position the clamping fixture along the **horizontal plane of the pipe, but not on the top or bottom**. Make sure the chains on both blocks are on the same side of the fixture and are opposite the ruler.

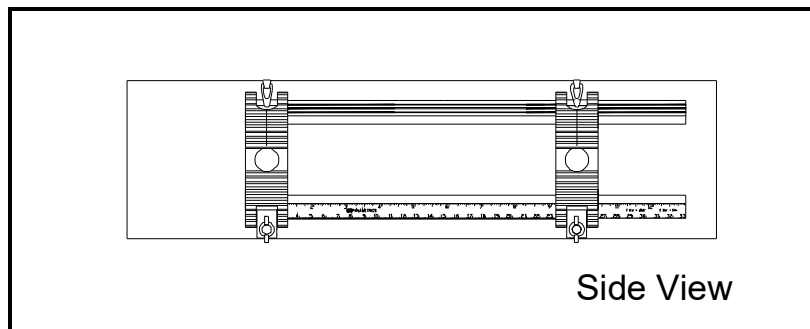



- 
6. Wrap the chain around the pipe and fasten the chain on the J screw hook on the opposite side of the block. Do this for both blocks.

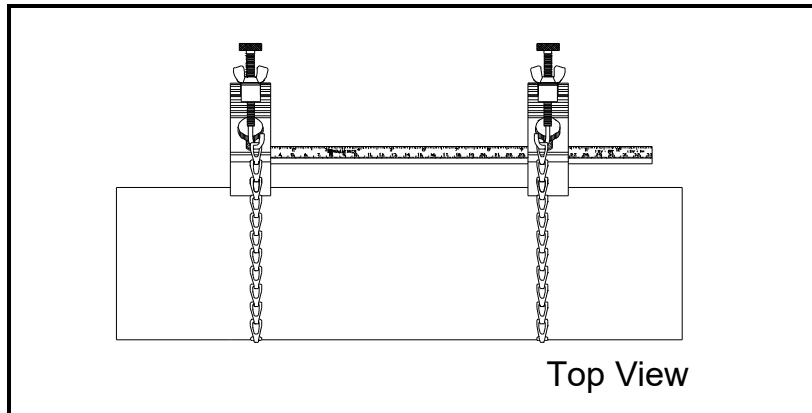

7. Using the screw hook on the blocks, tighten the chains until the fixture is secured snugly to the side of the pipe.

**Note:** *Make sure the chains are perpendicular to the clamping fixture and are not twisted. If the chains are slanted, the slack may cause the fixture to move around. The slack may also change the transducer spacing after the transducers are mounted.*

Figure 4 shows a completed double-traverse installation without transducers. Proceed to *Mounting Transducers into the UCF* on page 16.

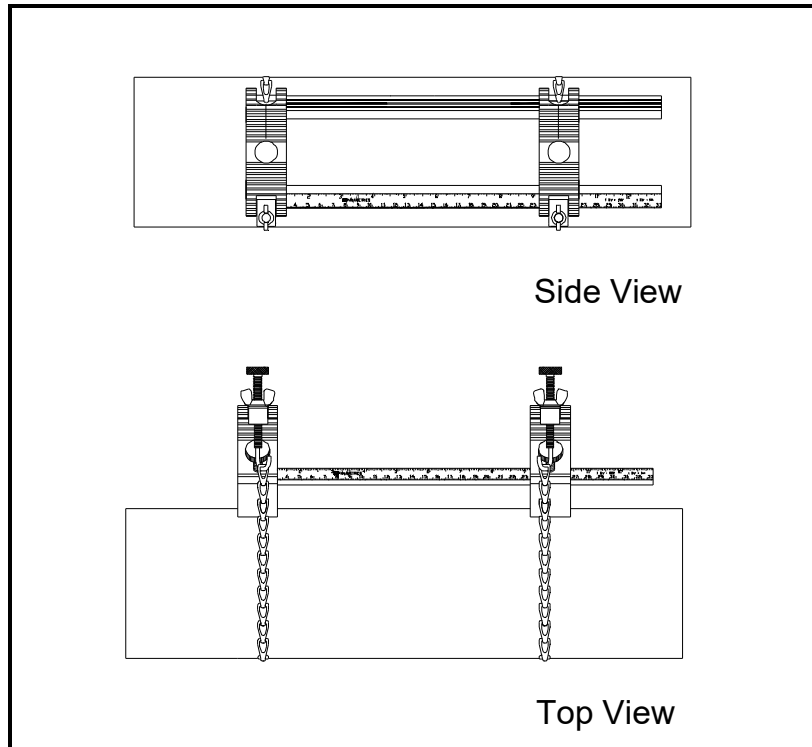

**Figure 4: A Double-Traverse Clamping Fixture Installation (w/o transducers)**

## 5.2.4 The Single-Traverse Method - UCF

**Note:** The instructions in this section can also be used for a multiple-traverse method. However, you must use an ODD number of traverses. The distance the signal travels from one side of the pipe wall to the opposite side of the pipe wall is considered one traverse.

The procedure for mounting the UCF for the single-traverse method requires a long block and two short blocks. The long block is fastened to the pipe first and then the short block assembly is properly aligned and fastened at 180° from the long block.

You will need a marker or scribe to locate and mark the transducer locations on the pipe. Do the following:

1. Obtain the transducer spacing dimension  $S$ , as described in the programming section of the *Startup Guide*.
2. Be sure the location you have chosen for the installation has at least 10 pipe diameters of straight, undisturbed flow upstream and 5 pipe diameters downstream of the measurement point.
3. Prepare the pipe where you intend to place the UCF by making sure it is clean and free of loose material. Sanding, though usually not required, may be necessary to take off any high spots. However, be careful to preserve the original curvature of the pipe and not to eradicate the marks on the pipe.
4. Find the top of the pipe and use a level to draw a line parallel to the pipe's axis.

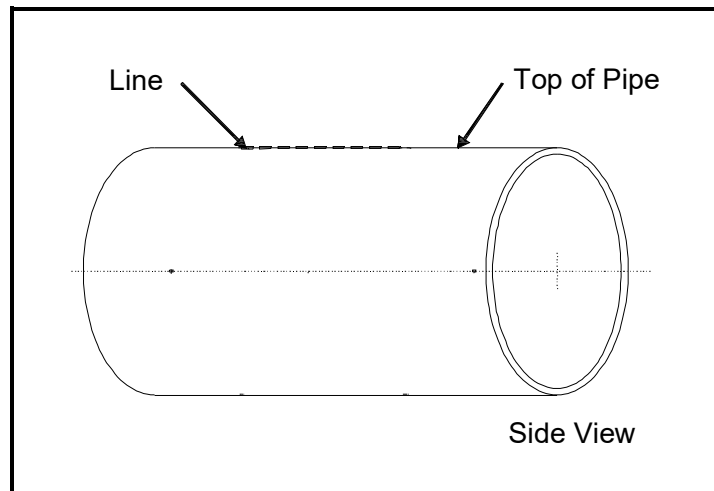

5. Make two marks on the line equal to the transducer spacing distance  $S$ , as calculated by the meter.

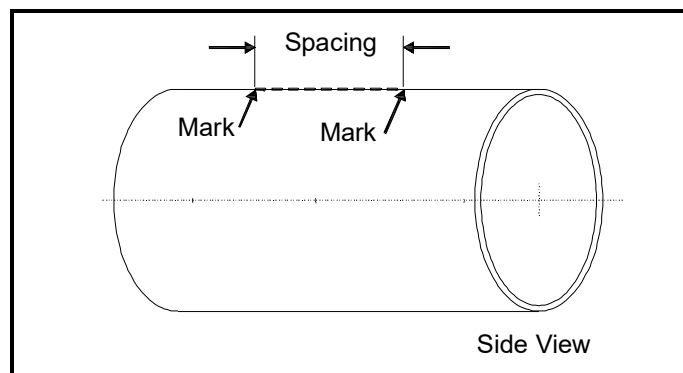

6. From one of the marks, measure around the circumference of the pipe a distance equal to one quarter the pipe's circumference and make a crossmark with the marker or scribe.

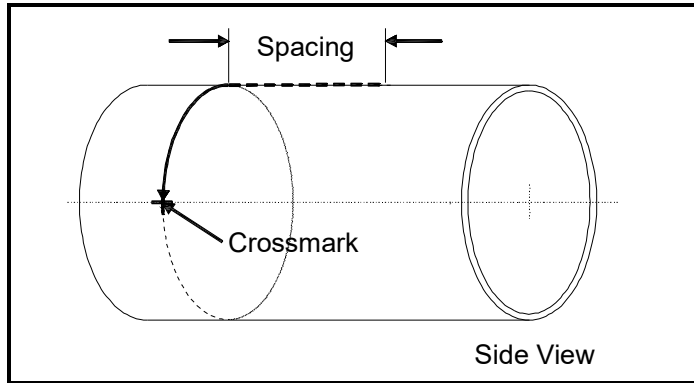

- From the other mark, go in the other direction around the pipe for one quarter the circumference and make another crossmark.

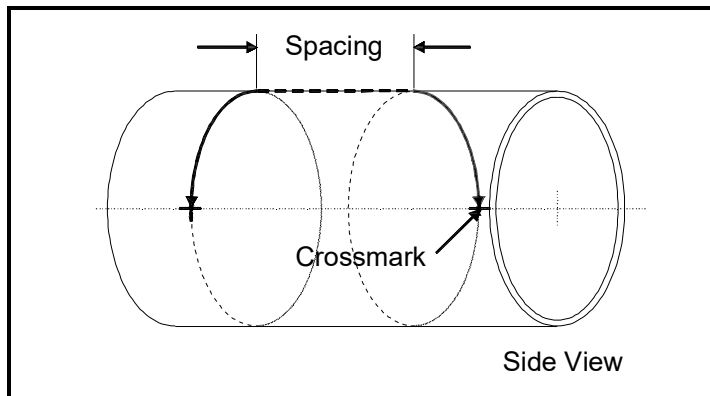

- Center the long block over one of the crossmarks on the pipe. Align the long block so that the pressure bolt is over the center of the crossmark. Fasten the block by wrapping both chains around the pipe and fastening the chains to the screw hooks on the opposite side of the block.

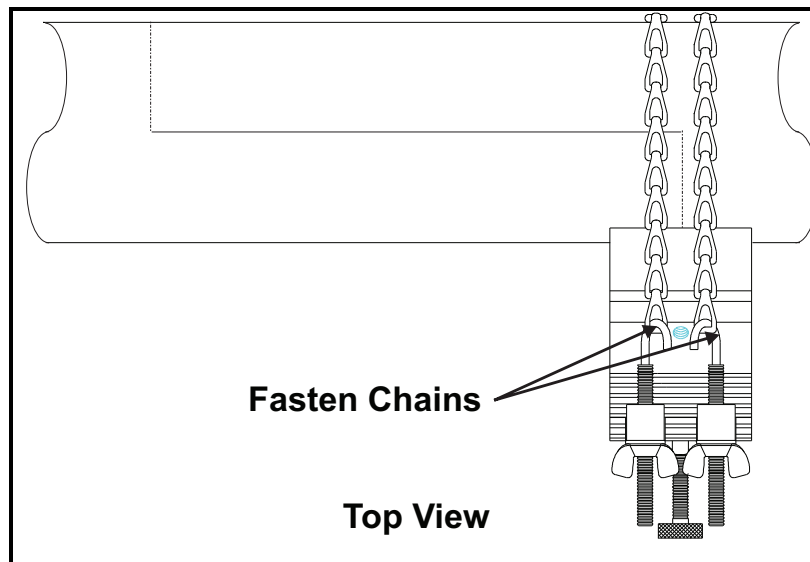

- Use the wing nuts to tighten the chains on the long block until it is secured snugly to the pipe.

**Note:** Make sure both chains are perpendicular to the bottom of the block and are not twisted. If the chains are slanted, the slack will cause the block to slide.

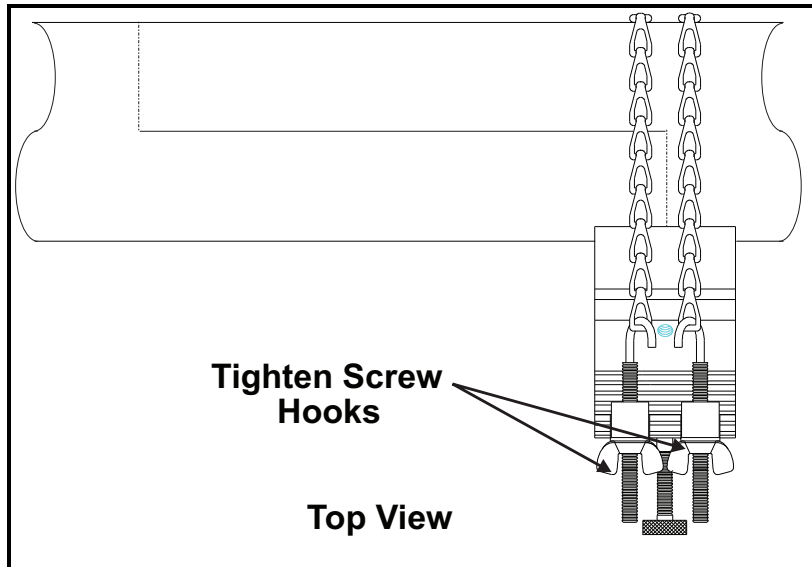

10. Position the clamping fixture rails so that one of the short blocks is placed over the remaining crossmark on the opposite side of the pipe and the pressure bolt is over the center of the crossmark. Make sure the block does not lie on top of the chains of the long block.

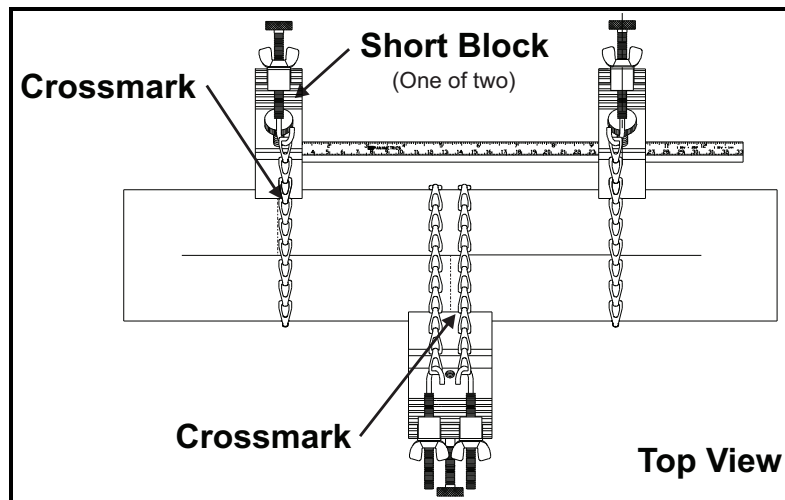

11. Wrap the chain around the pipe and fasten the chain to the screw hook on the opposite side of the block. Do this for both short blocks.

**Note:** Make sure the chains on both blocks are on the same side of the fixture and are opposite the ruler.

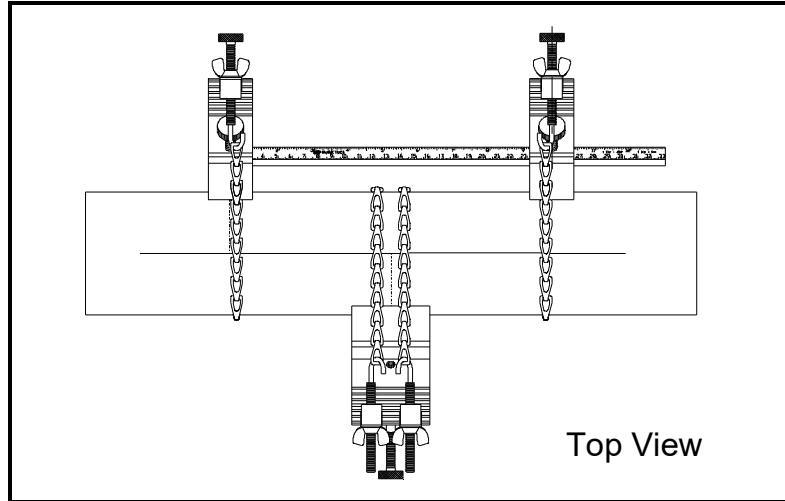

12. Tighten the pressure bolt all the way down on the short block that is **NOT** positioned over the crossmark. This will act as a reminder to not install the transducer in that block.

13. Use the screw hooks to tighten the chains on the fixed and adjustable blocks until the blocks are secured snugly to the pipe.

**Note:** Make sure both chains are perpendicular to the clamping fixture and are not twisted. If the chains are slanted, the slack will cause the blocks to slide. The slack may also change the transducer spacing after the transducers are mounted.

Figure 5 shows a completed single-traverse installation without transducers. Proceed to *Mounting Transducers into the UCF* on page 16.

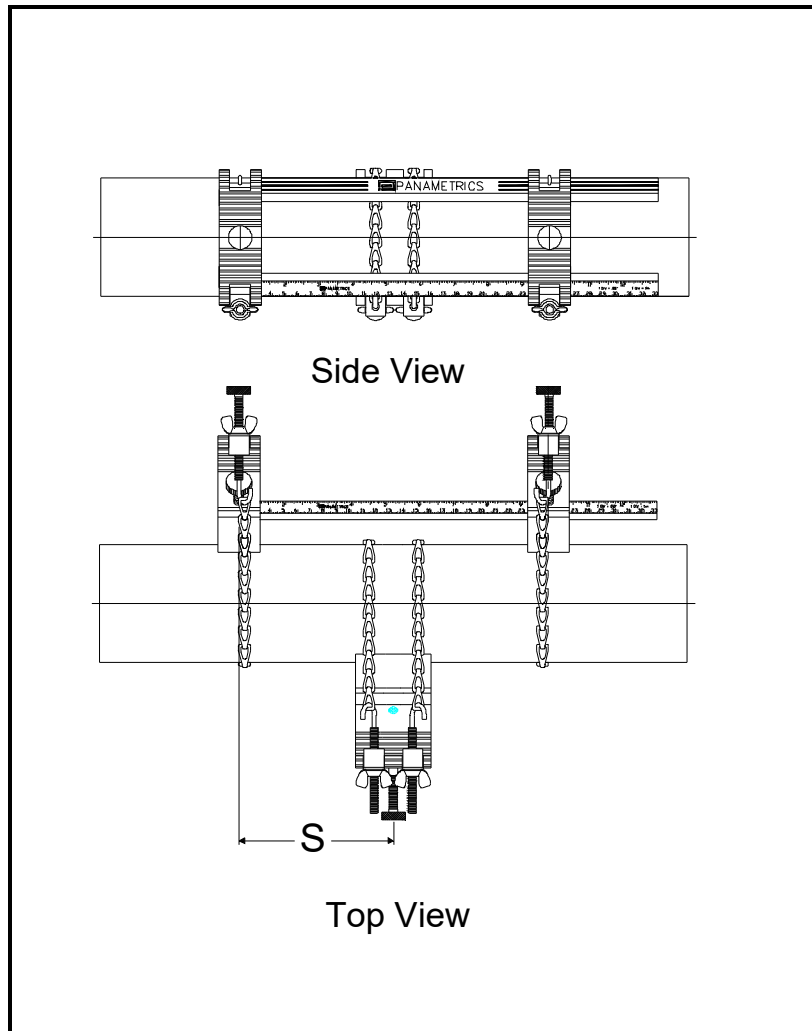

Figure 5: Single-Traverse Clamping Fixture Installation without Transducers

### 5.2.5 Mounting Transducers into the UCF

The last step of installation is mounting the transducers into the clamping fixture. C-PT transducers are manufactured with a dimple on top of the transducer body. In addition, there are scribe marks on each side.

To mount the transducers into the UCF, use the following steps:

1. Apply a thread sealant to the transducer threads. A sealant is not required within the US, however, a sealant must be used in European Communities.
2. Before mounting the transducers, thread the junction box onto the end of the transducer with the BNC connector. Ensure that at least five full threads are engaged. Make sure to orient the cover of the junction box so it is accessible to make cable connections once the box is installed.

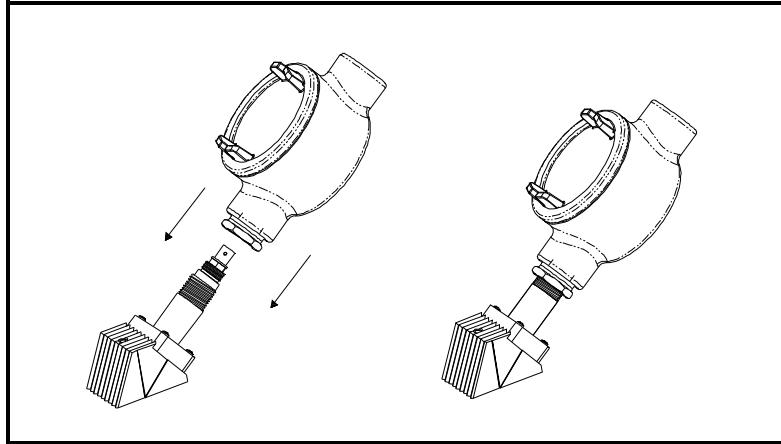

3. Take one of the transducers and apply a thin bead of couplant down the center of its face approximately the size of a toothpaste bead.

**IMPORTANT:** To prevent the loss of couplant, do not slide the transducer with couplant along the surface of the pipe when mounting.

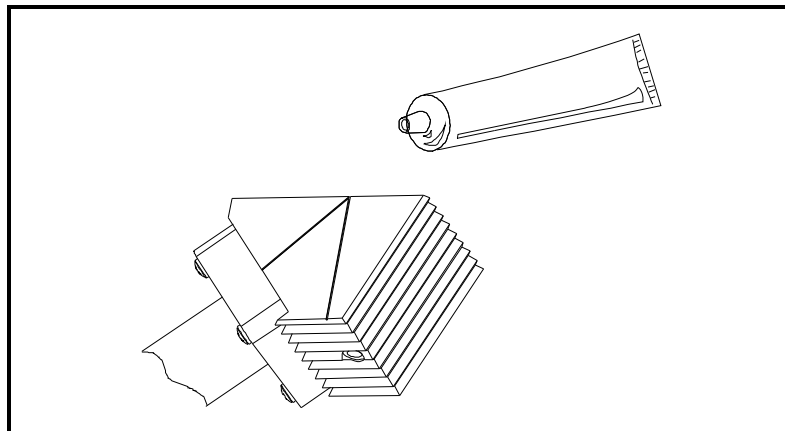



4. Place the transducers into the blocks. Make sure the junction box faces away from the block as shown below.

**Note:** If the transducer cables are already connected, you must determine the upstream and downstream directions of the pipe and place the transducers into the appropriate blocks.

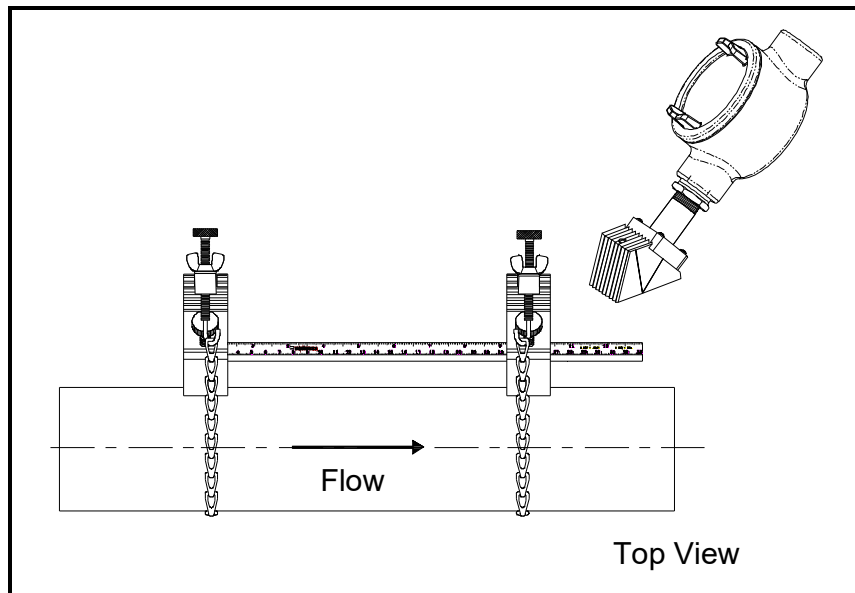

5. Use the pressure bolt to secure the transducer in place. The pressure bolt should fit into the dimple. Hand-tighten enough to hold the transducer in place. Do not overtighten so that the fixture lifts off the pipe.

**CAUTION!** To ensure against impact to the transducer face, it must always be mounted flush to the pipe.

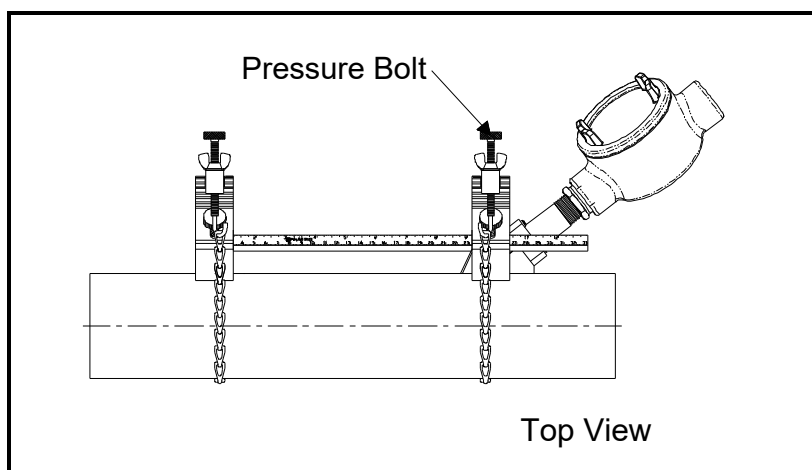

6. Tighten the counter nut on the pressure bolt (see Figure 3 on page 7).

**IMPORTANT:** When using the UCF in a pipe location with possible mechanical vibration, the locking nut must be used to secure the position of the pressure bolt on the transducer after the bolt has been hand-tightened into the transducer dimple. For additional resistance to vibration a thread lock compound or a stainless steel washer and lock washer may also be used. These items can be ordered from GE by requesting a special clamping fixture and specifying either the thread lock or the washers.

7. Repeat Steps 1 to 6 to mount the other transducer in the remaining block.

8. Tighten the thumbscrews on the short blocks to make sure the block is secure on the rail. See Figure 6 on page 18 for completed UCF installations.

**WARNING!** Before performing the next step make sure the power to the flowmeter electronics is disconnected.

9. Make transducer cable connections as described in the *Installation* chapter of the *Startup Guide*.

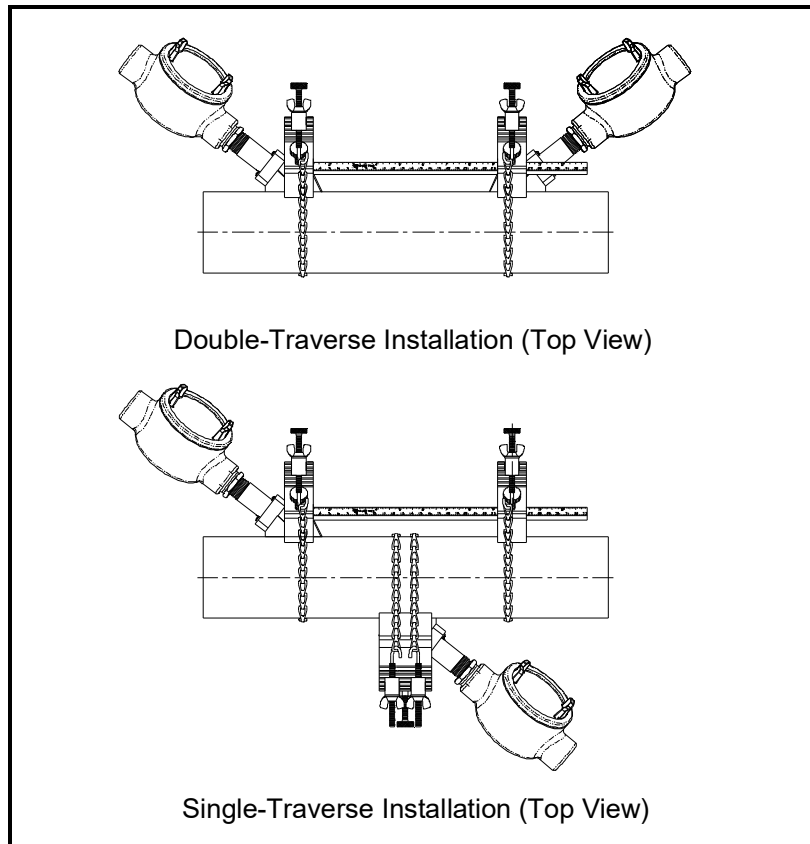

**Figure 6: Completed UCF Installations with Transducers**

**Note:** If you have mounted the transducers into the UCF properly, the two transducer cable connectors will face away from each other as shown in Figure 6.

### 5.3 Installing the General Clamping Fixture - GCF

The General Clamping Fixture (GCF) acts as a permanent transducer holder. The fixture has two blocks that are used for double- and single-traverse methods. Steel straps secure the blocks to the pipe for a permanent installation.

The blocks are positioned properly using the spacing dimension calculated by the flowmeter. Then the transducers are mounted into the blocks. Figure 7 shows a long block.

The transducer installation consists of mounting the GCF to the pipe and then mounting the transducers into the blocks. Refer to the appropriate section that follows for instructions:

- Double-traverse Method - below
- Single-traverse Method - page 21

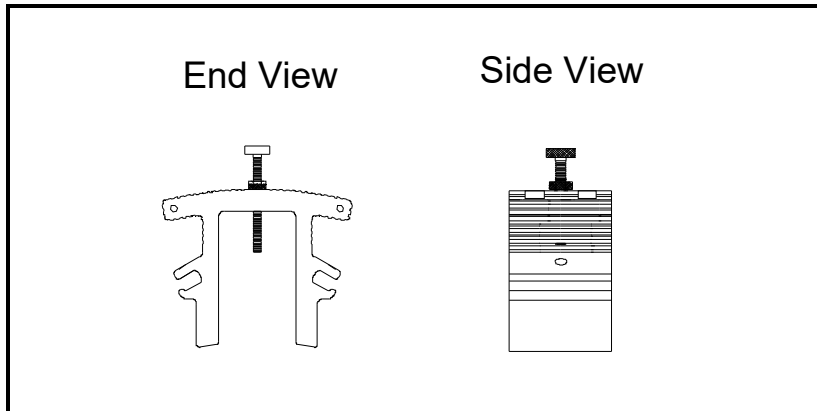

Figure 7: General Clamping Fixture Block

### 5.3.1 The Double-Traversal Method - GCF

**Note:** The instructions in this section can also be used for a multiple-traverse method. However, you must use an *EVEN* number of traverses. The distance the signal travels from one side of the pipe wall to the opposite side of the pipe wall is considered one traverse. For more than two traverses, consult the GE factory.

There are three advantages in using the double-traverse method:

- Accuracy is improved because the signal is in the fluid longer than with a single-traverse.
- This configuration can reduce some effects of an underdeveloped flow profile.
- If there is enough pipe length available, the double-traverse fixture is easier to install.

The procedure for mounting the GCF involves marking the pipe for the desired spacing, fastening the clamping fixture on the pipe and then mounting the transducers into the fixture.

You will need a level and a marker or scribe to locate and mark the transducer locations on the pipe.

1. Obtain the transducer spacing dimension  $S$ , as described in the programming section of the *Startup Guide*.
2. Be sure the location you have chosen for the installation has at least 10 pipe diameters of straight, undisturbed flow upstream and 5 pipe diameters downstream of the measurement point.
3. Prepare the pipe where you intend to place the clamping fixture by making sure it is clean and free of loose material. Sanding, though usually not required, may be necessary to take off any high spots. Be careful to preserve the original curvature of the pipe.
4. Find the top of the pipe and use a level to draw a line parallel to the pipe's axis.

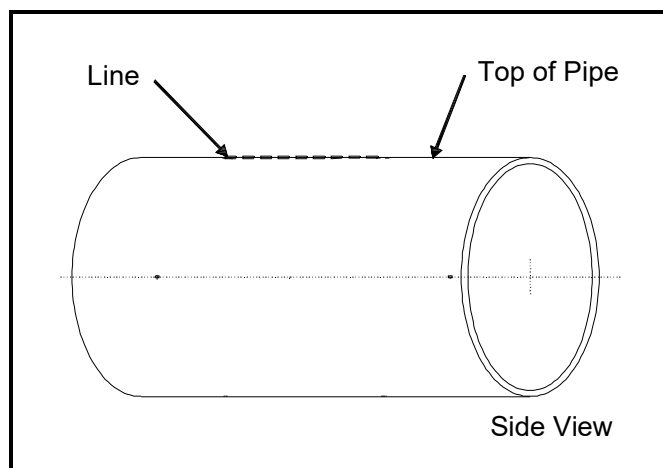

5. Make two marks on the line equal to the transducer spacing distance  $S$ , as calculated by the meter.

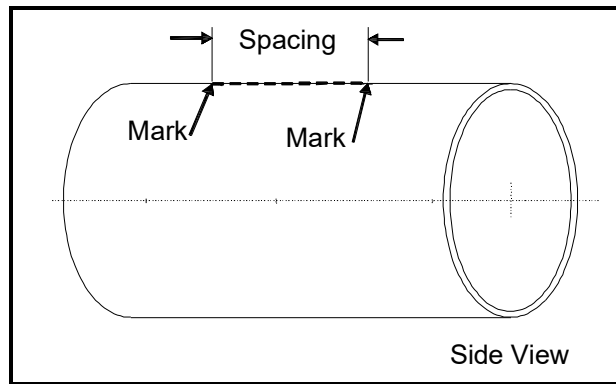

6. From each of the marks, measure around the circumference of the pipe a distance equal to one quarter the pipe's circumference. Make a crossmark with a marker or scribe.

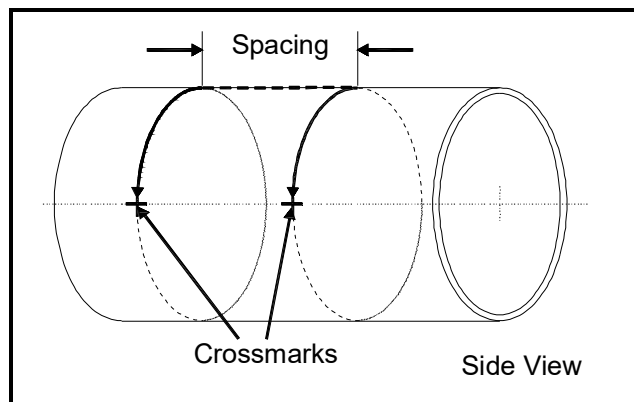

7. Center one of the blocks over one of the crossmarks on the pipe. Align the block so that the pressure bolt is over the center of the mark. Secure the block by wrapping the two straps around the block and pipe and tightening them. Make sure the turnbuckles are at least  $1/2$  pipe diameter away from the clamping fixture.

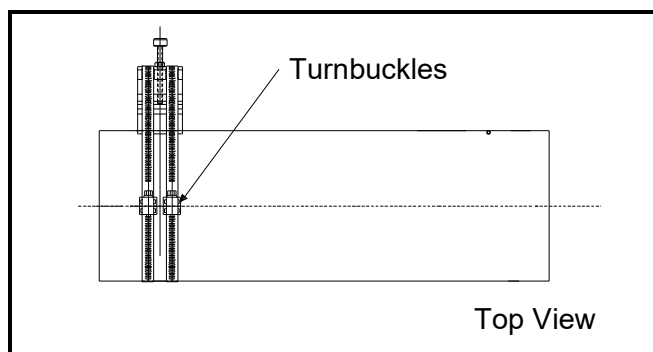

8. Repeat Step 7 to install the other block over the other crossmark.

**Note:** Make sure both straps are perpendicular to the bottom of the block. If the straps are slanted, the slack will cause the block to slide. The slack may also change the transducer spacing after the transducers are mounted.

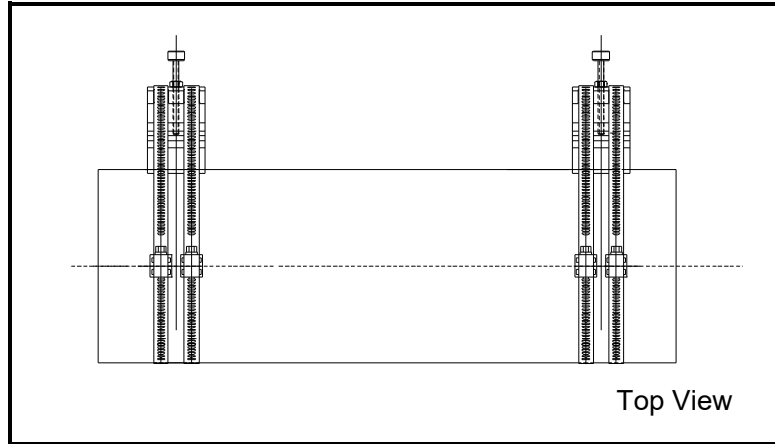

Figure 8 shows a double-traverse installation without transducers. Proceed to *Mounting Transducers into the GCF* on page 26.

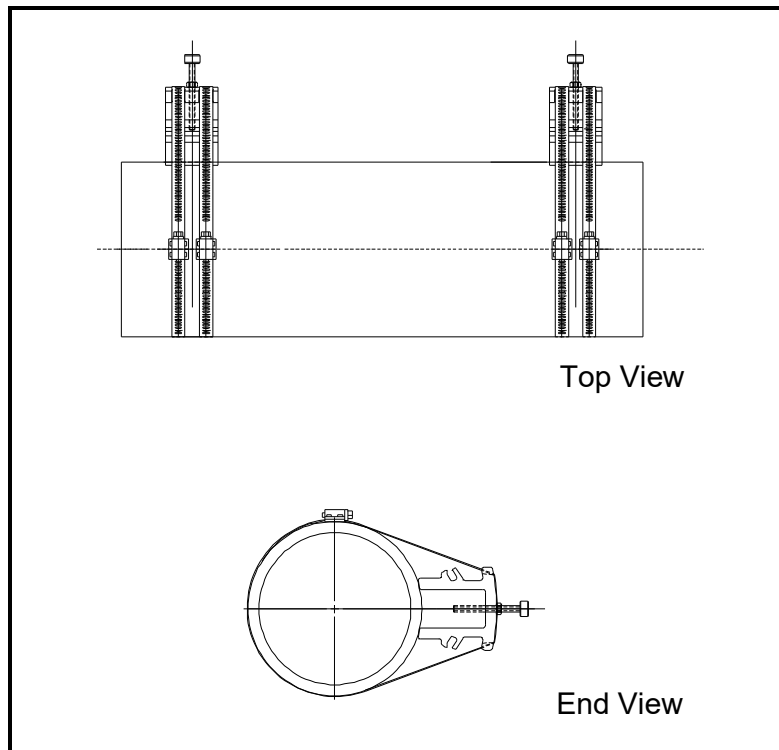

Figure 8: A Double-Traverse GCF Installation without Transducers

### 5.3.2 The Single-Traverse Method - GCF

**Note:** The instructions in this section can also be used for a multiple-traverse method. However, you must use an ODD number of traverses. The distance the signal travels from one side of the pipe wall to the opposite side of the pipe wall is considered one traverse.

The procedure for mounting the GCF involves marking the pipe for the desired spacing, fastening the fixture to the pipe and then mounting the transducers into the fixture.

You will need a level and marker or scribe to locate the transducers on the pipe.

1. Obtain the transducer spacing dimension  $S$ , as described in the programming section of the *Startup Guide*.
2. Be sure the location you have chosen for the installation has at least 10 pipe diameters of straight, undisturbed flow upstream and 5 pipe diameters downstream of the measurement point.
3. Prepare the pipe where you intend to place the GCF by making sure it is clean and free of loose material. Sanding, though usually not required, may be necessary to take off any high spots. Be careful to preserve the original curvature of the pipe and not to eradicate the marks on the pipe.
4. Find the top of the pipe and use a level to draw a line parallel to the pipe's axis.

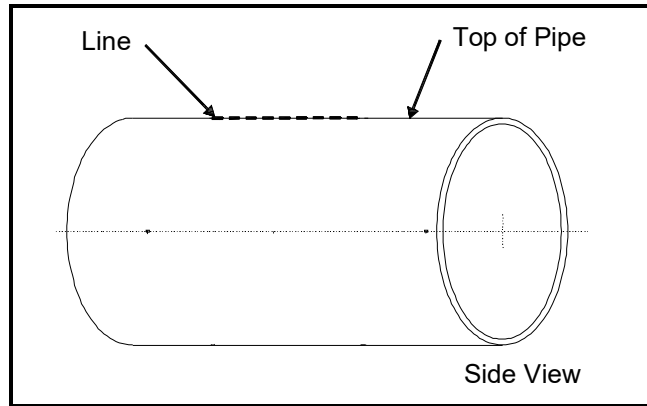

5. Make two marks on the line equal to the transducer spacing distance  $S$ , as calculated by the meter.

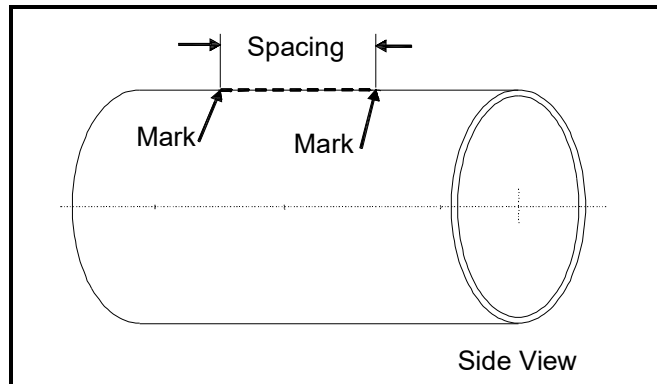

6. From one of the marks, measure around the circumference of the pipe a distance equal to one quarter the pipe's circumference. Make a crossmark with a marker or scribe.

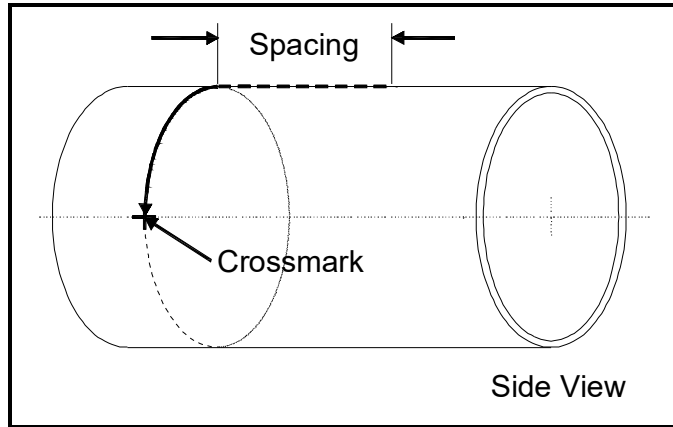

7. From the other mark, go in the opposite direction around the pipe for one quarter the circumference and make another crossmark.

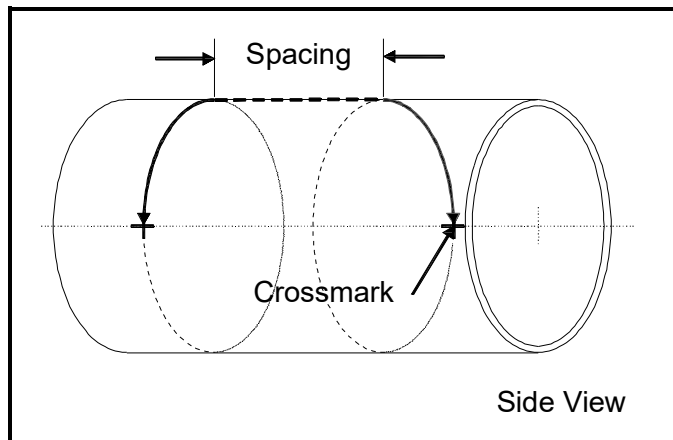

8. Center one of the blocks over one of the crossmarks on the pipe. Align the block so that the pressure bolt is over the center of the crossmark. Secure the block by wrapping two straps around the block and pipe and tightening them. Make sure the turnbuckles are at least 1/2 pipe diameter away from the clamping fixture.

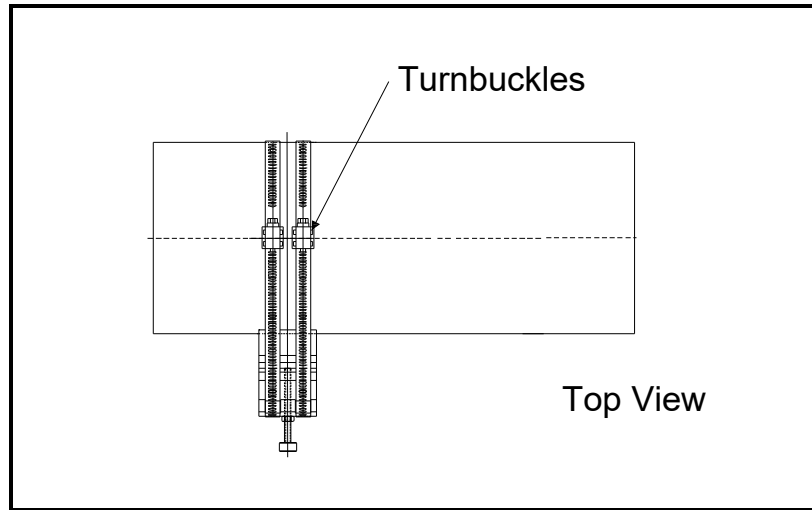

9. Repeat Step 8 to install the other block over the other punch mark.

**Note:** Make sure both straps are perpendicular to the bottom of the block. If the straps are slanted, the slack will cause the block to slide. The slack may also change the transducer spacing after the transducers are mounted.

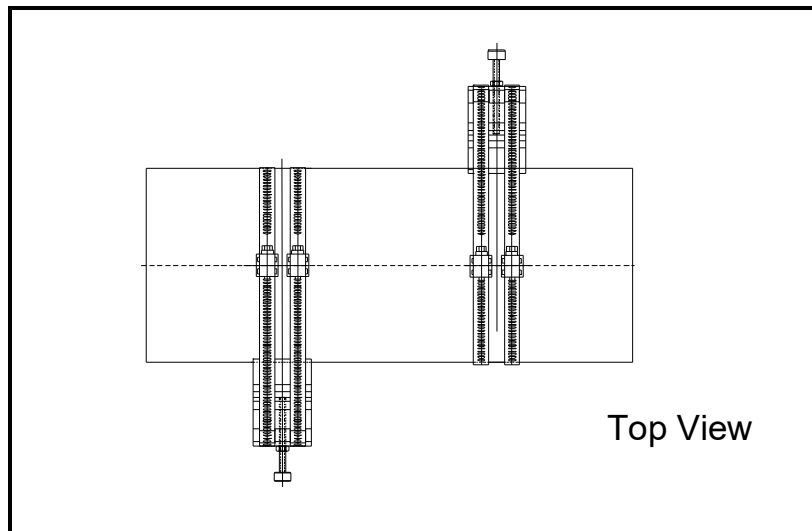
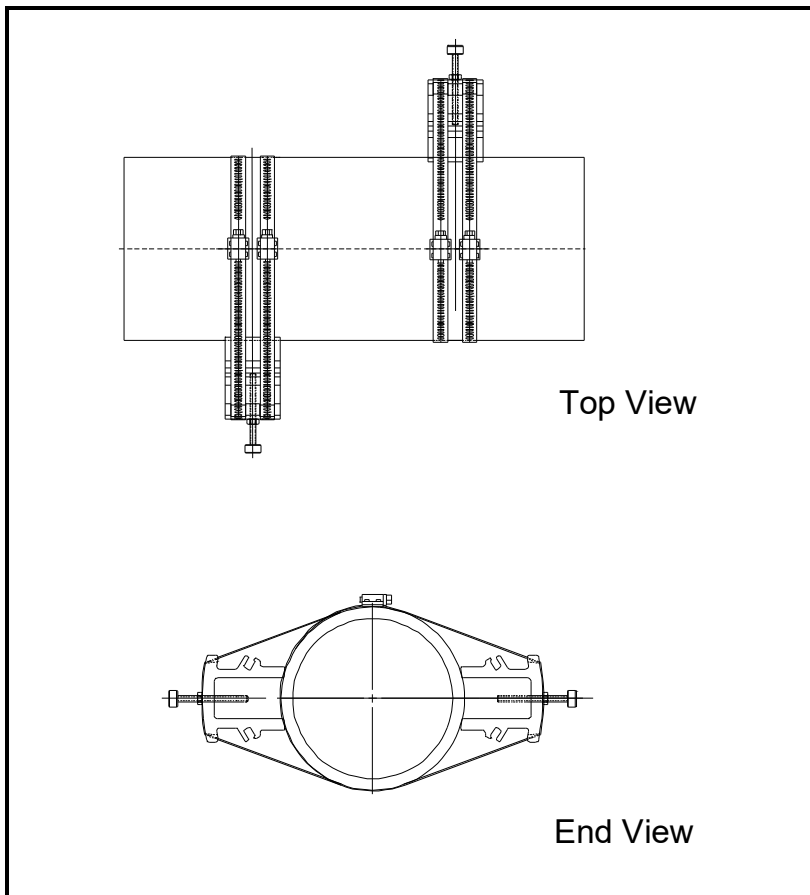



Figure 9 shows a single-traverse installation without transducers. Proceed to *Mounting Transducers into the GCF* on page 26.



**Figure 9: A Single-Traverse GCF Installation without Transducers**

### 5.3.3 Mounting Transducers into the GCF

The last step of installation is mounting the transducers into the clamping fixture. C-PT transducers are manufactured with a dimple on top of the transducer body. In addition, there are scribe marks on each side.

To mount the transducers into the GCF, use the following steps:

1. Apply a thread sealant to the transducer threads. A sealant is not required within the US, however, a sealant must be used in European Communities.
2. Before mounting the transducers, thread the junction box onto the end of the transducer with the BNC connector. Ensure that at least five full threads are engaged. Make sure to orient the cover of the junction box so it is accessible to make cable connections once the box is installed.

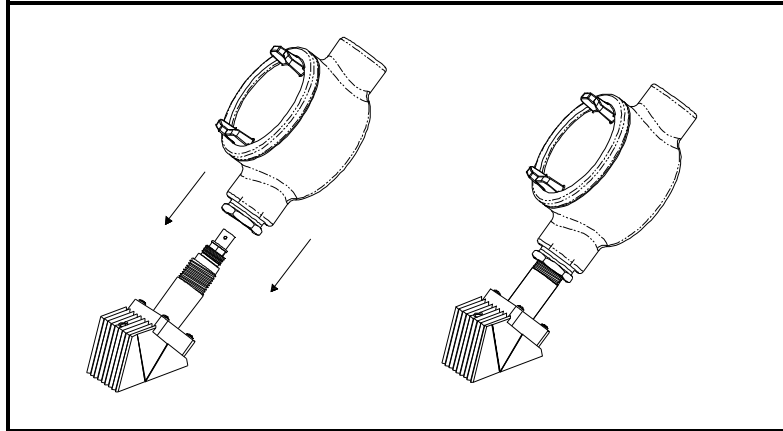

3. Take one of the transducers and apply a thin bead of couplant down the center of its face approximately the size of a toothpaste bead.

**IMPORTANT:** To prevent the loss of couplant, do not slide the transducer with couplant along the surface of the pipe when mounting.

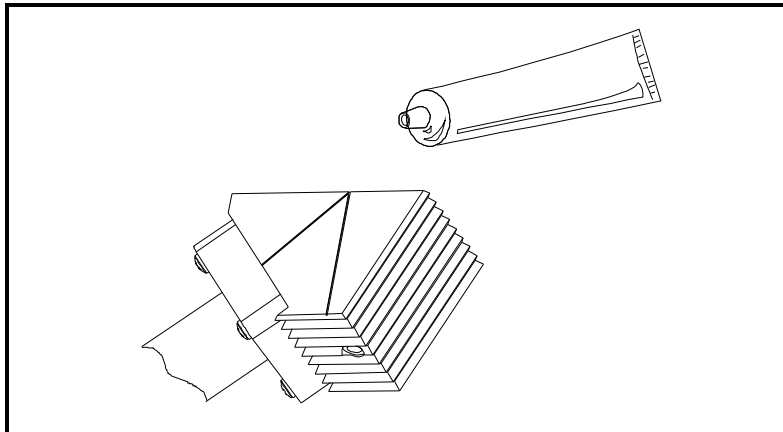

4. Place the transducers in the appropriate blocks. Make sure the transducers are oriented as shown below.

**CAUTION!** To ensure against impact to the transducer face, it must always be mounted flush to the pipe.

**Note:** If the transducer cables are already connected, you must determine the upstream and downstream directions of the pipe and place the transducers into the appropriate blocks.

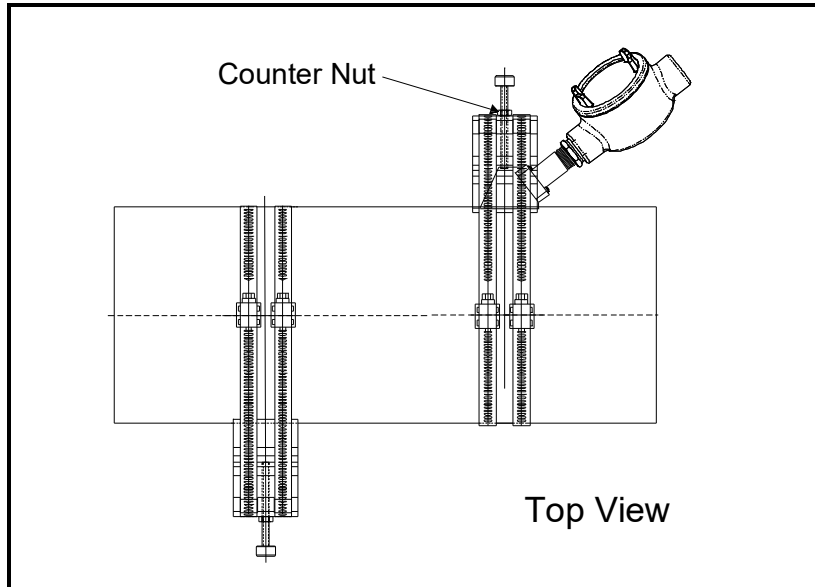

5. Use the pressure bolt to secure the transducer in place. The pressure bolt should fit into the dimple. Hand-tighten enough to hold the transducer in place. Do not overtighten so that the fixture lifts off the pipe.
6. Tighten the counter nut on the pressure bolt (see above).

**IMPORTANT:** When using the GCF in a pipe location with possible mechanical vibration, the locking nut must be used to secure the position of the pressure bolt on the transducer after the bolt has been hand-tightened into the transducer dimple. For additional resistance to vibration a thread lock compound or a stainless steel washer and lock washer may also be used. These items can be ordered from GE by requesting a "special" clamping fixture and specifying either the thread lock or the washers.

7. Repeat Steps 1 to 6 to mount the other transducer in the remaining block. See Figure 10 on page 28 for completed installations.

**WARNING!** Before performing the next step make sure the power to the flowmeter electronics is disconnected.

8. Make transducer cable connections as described in the *Installation* chapter of the *Startup Guide*.

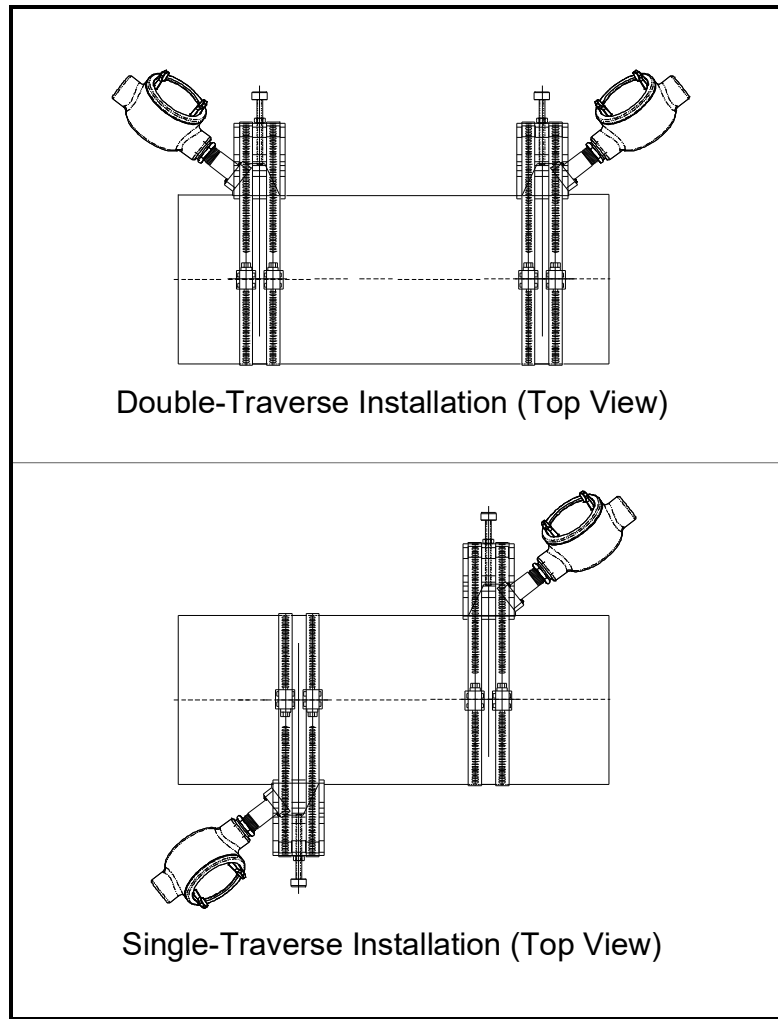

**Figure 10: Completed GCF Installations with Transducers**

**Note:** If you have mounted the transducers into GCF properly, the two transducer cable connectors will face away from each other as shown in Figure 10.

## 5.4 Installing the Magnetic Clamping Fixture - MCF

The Magnetic Clamping Fixture (MCF) is used to fasten transducers to the pipe at the proper spacing **without** chains or straps. The MCF is used on ferrous pipe materials only.

Different fixtures are used for a single- and double-traverse installation. Each type of MCF has magnets at either end of the fixtures. When the magnets are turned ON, the fixture magnetically "clamps" to the pipe wall.

To properly mount the MCF, you should become familiar with the components of each type of fixture.

### 5.4.1 Identifying the MCF Components

Refer to Figure 11 to identify these components, then refer to one of the following sections to install the clamping fixture:

- Double-traverse Method - page 30
- Single-traverse Method - page 32

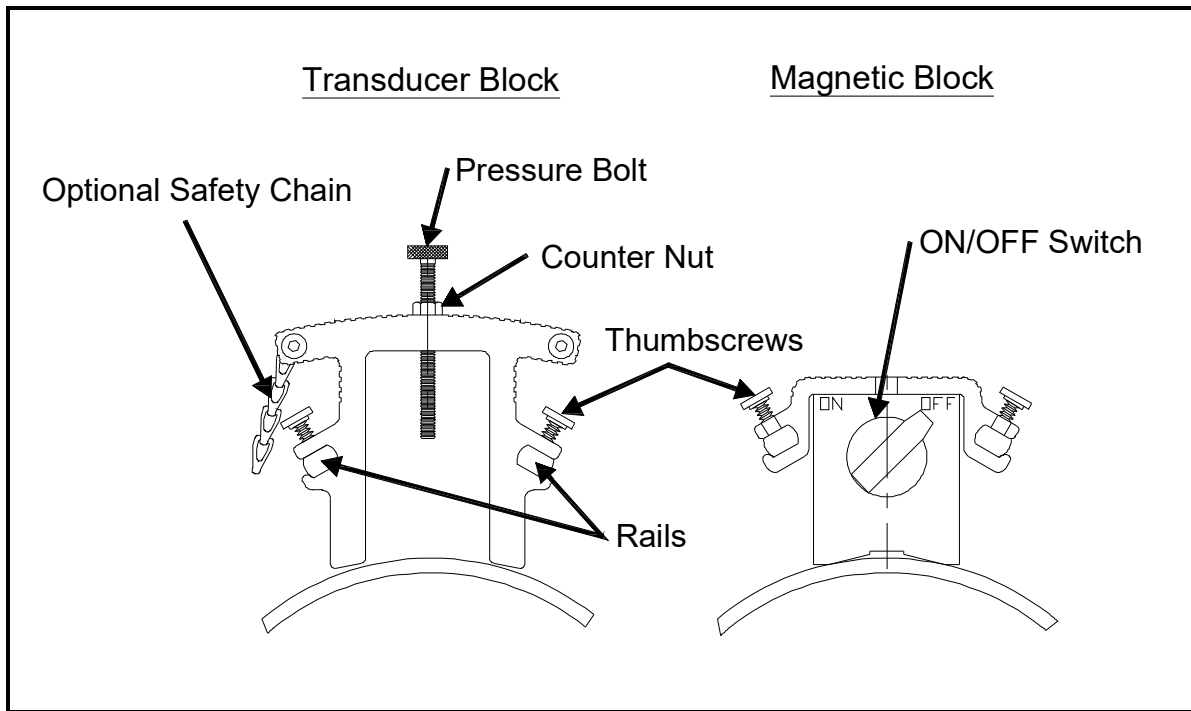

Figure 11: Transducer Block and Magnetic Block

### 5.4.2 The Double-Traversal Method - MCF

The Double-Traversal MCF consists of two blocks connected by two rods (one of the two rods acts as a scale or ruler to help you properly space transducers). Both blocks are adjustable. This type of fixture has two transducer blocks and like the magnetic blocks, both are adjustable.

The procedure for mounting the MCF involves setting the transducer spacing and then securing the fixture to the pipe.

**WARNING!** Do not use the MCF at temperatures that exceed 120°F (49°C), or the fixture will fall off the pipe.

To install the MCF in a double-traverse configuration:

**Note:** The instructions that follow can be used for a multiple-traverse method. However, you must use an *EVEN* number of traverses. The distance the signal travels from one side of the pipe wall to the opposite side of the pipe wall is considered one traverse.

1. Obtain the transducer spacing dimension  $S$ , as described in the programming section of the *Startup Guide*.
2. Be sure the location you have chosen for the installation has at least 10 pipe diameters of straight, undisturbed flow upstream and 5 pipe diameters downstream of the measurement point.
3. Prepare the pipe where you intend to place the clamping fixture by making sure it is clean and free of loose material. Sanding, though usually not required, may be necessary to take off any high spots. Be careful to preserve the original curvature of the pipe.
4. Using the scale on the rod, move the blocks so they are located a distance equal to the spacing dimension from each other. To move the block, loosen the red thumb screws, slide the block to the desired location and tighten the thumb screws. Use the pressure bolt or the edge of the block as the measuring point for the block.

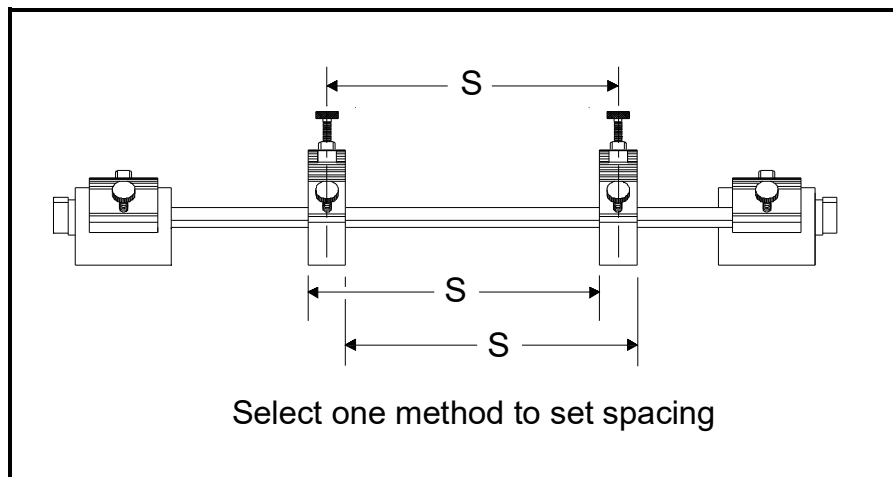

5. Locate the magnetic blocks at least 4 in. away from the transducer blocks. This will ensure that there is enough clearance to mount the transducers in the blocks. Move the adjustable magnetic block in the same manner as the transducer block.

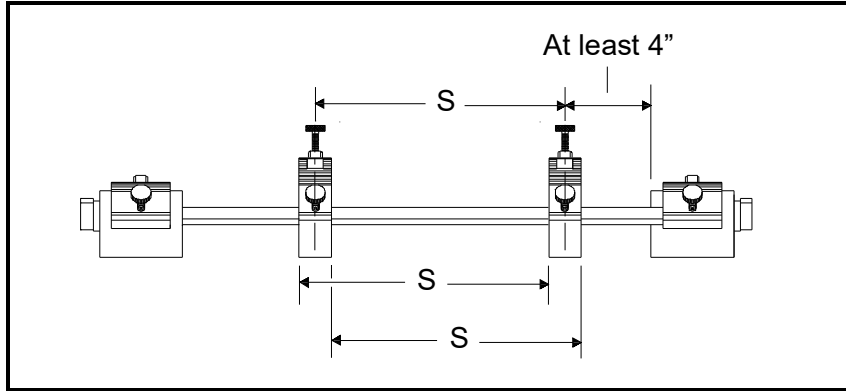

6. Position the clamping fixture along the horizontal plane of the pipe. If the pipe is horizontal, do not place the fixture on the top or bottom of the pipe.

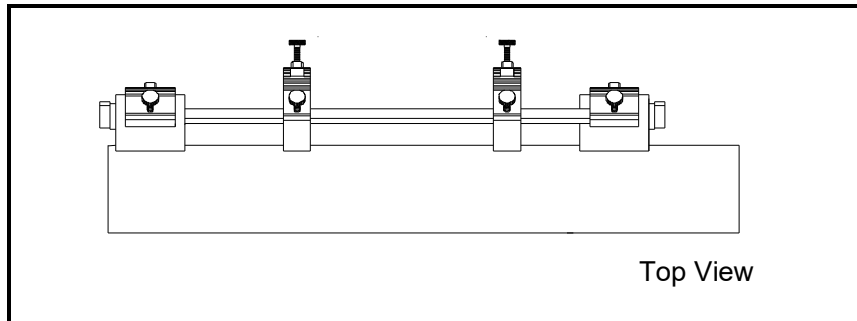

7. Turn the switches on each magnet to the ON position.

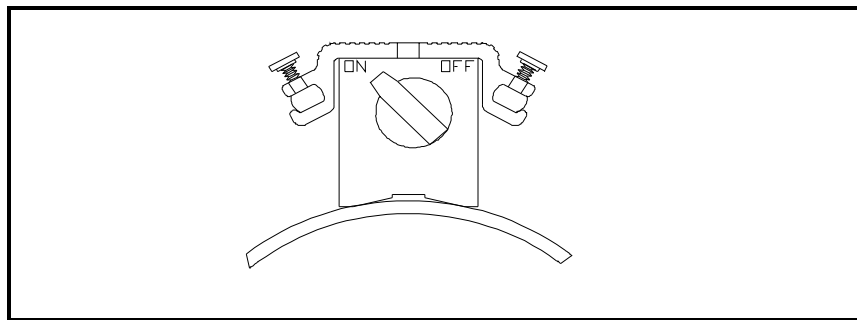

8. If provided, secure the safety chain. The safety chain prevents the fixture from falling of the pipe in the event the magnet releases.
9. Proceed to *Mounting Transducers into the MCF* on page 35.

### 5.4.3 The Single-Traversal Method - MCF

The Single-Traversal MCF consists of two parts. Each part is made up of two magnetic blocks which are connected by two rods. In addition, a sliding transducer block, which is used to hold the transducer in proper alignment, is positioned on the two rods. Each part is positioned on the pipe to face 180° opposite each other.

**Note:** *In some cases, a magnetic clamping fixture with two transducer blocks is used.*

The procedure for mounting the MCF involves marking the pipe and then securing the fixtures to the pipe.

**WARNING!** Do not use magnetic fixtures at temperatures that exceed 120°F (49°C), or the fixture will fall off the pipe.

To install the MCF in a single-traverse configuration:

**Note:** *The instructions in this section can also be used for a multiple-traverse method. However, you must use an ODD number of traverses. The distance the signal travels from one side of the pipe wall to the opposite side of the pipe wall is considered one traverse.*

1. Obtain the transducer spacing dimension  $S$ , as described in the programming section of the *Startup Guide*.
2. Be sure the location you have chosen for the installation has at least 10 pipe diameters of straight, undisturbed flow upstream and 5 pipe diameters downstream of the measurement point.
3. Prepare the pipe where you intend to place the MCF by making sure it is clean and free of loose material. Sanding, though usually not required, may be necessary to take off any high spots. Be careful to preserve the original curvature of the pipe and not to eradicate the marks on the pipe.
4. Find the top of the pipe and use a level to draw a line parallel to the pipe's axis.

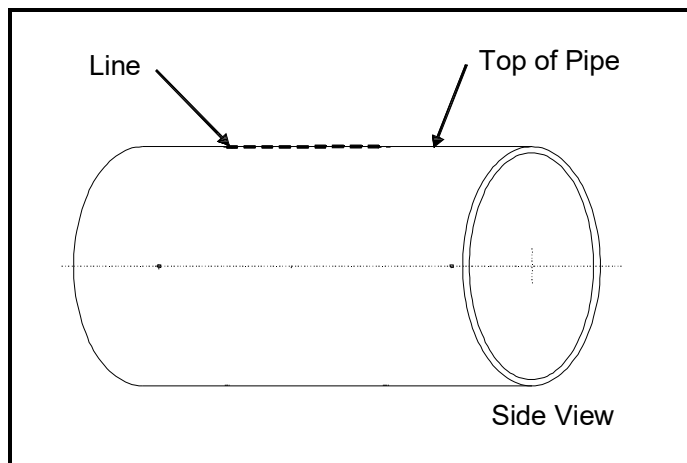

5. Make two marks on the line separated by the transducer spacing distance  $S$ , as calculated by the meter.

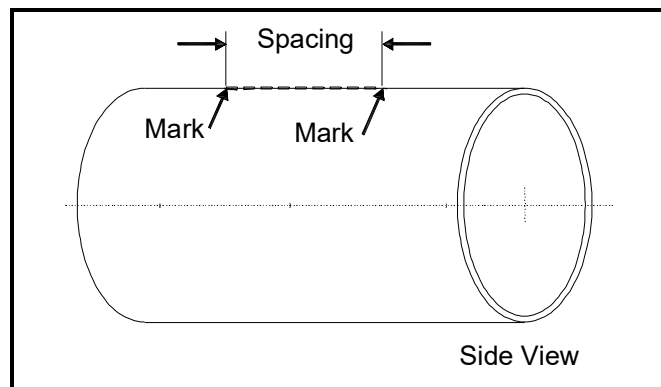



- From one of the marks, measure around the circumference of the pipe a distance equal to one quarter the pipe's circumference. Use a marker or scribe to make a crossmark.

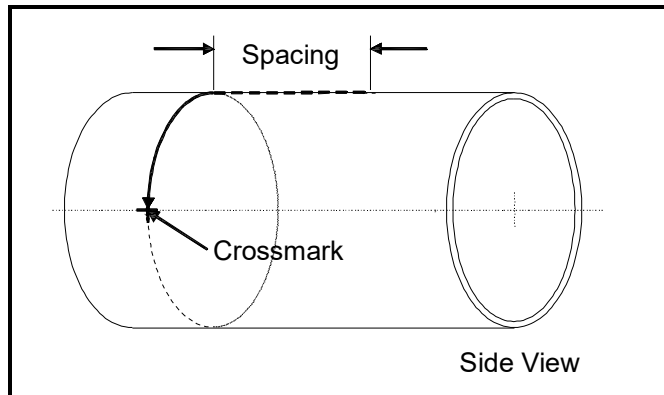

- From the other mark, go in the opposite direction around the pipe for one quarter the circumference and make another crossmark.

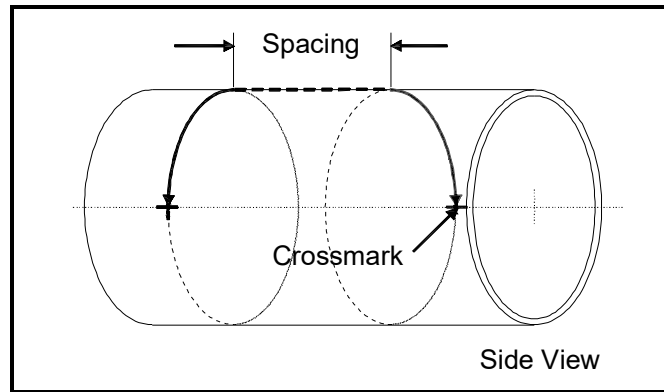

- On one of the fixtures, position the transducer block anywhere along the rods, being sure to leave enough room on either side to easily insert the transducer. To move the block, loosen the red thumbscrews, slide the block to the desired location and tighten the thumbscrews. Use the pressure bolt as the measuring point for the block. Repeat for the other fixture.

**Note:** If you are using a fixture with two transducer blocks, adjust one block as described above and push the unused block all the way to one side of the rail. Tighten the pressure bolt all the way down on the unused block. This will act as a reminder to not install the transducer in that block.

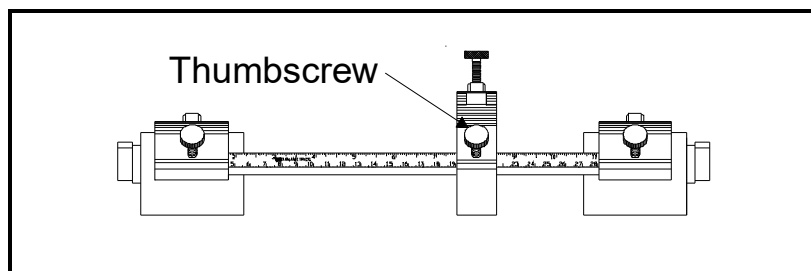

- Center the block over one of the marks on the pipe. Align it such that the pressure bolt on the transducer block is right over the center of the crossmark.

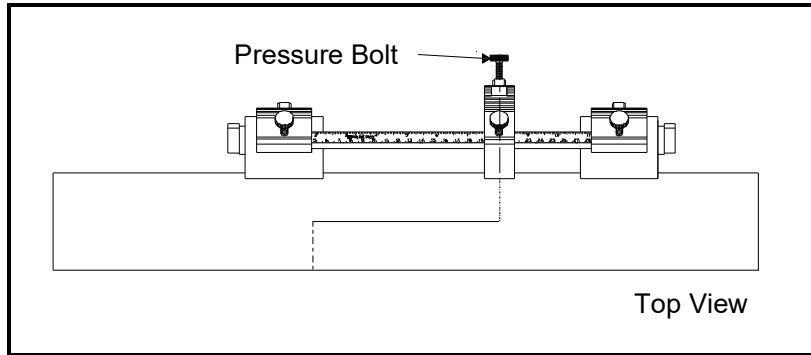

10. Turn the switches on each magnet to the ON position.

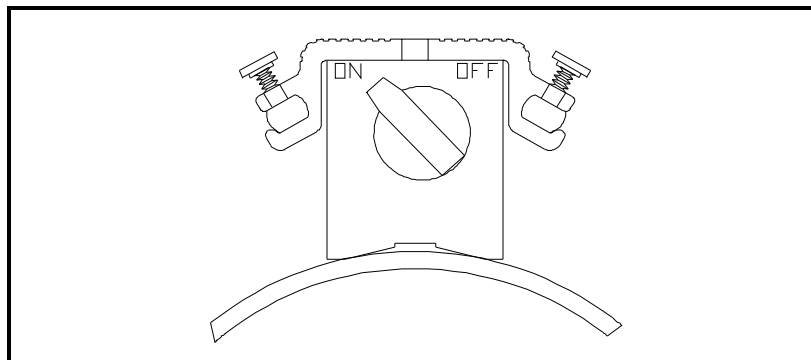

11. Repeat Steps 9 and 10 for the other fixture on the opposite pipe marking.

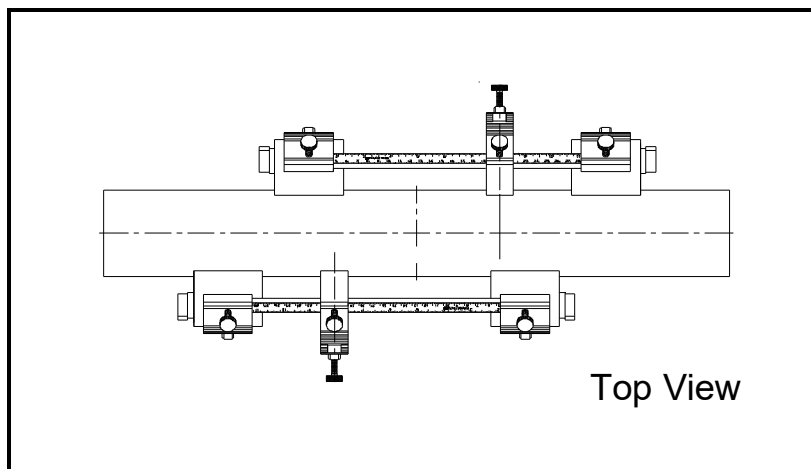

12. If provided, secure the safety chain. The safety chain prevents the fixture from falling off the pipe in the event the magnet releases.

Proceed to *Mounting Transducers into the MCF* on page 35.

#### 5.4.4 Mounting Transducers into the MCF

The last step of installation is mounting the transducers into the clamping fixture. C-PT transducers are manufactured with a dimple on top of the transducer body. In addition, it also has scribe marks on each side.

To mount the transducers into the MCF, use the following steps:

1. Apply a thread sealant to the transducer threads. A sealant is not required within the US, however, a sealant must be used in European Communities.
2. Before mounting the transducers, thread the junction box onto the end of the transducer with the BNC connector. Ensure that at least five full threads are engaged. Make sure to orient the cover of the junction box so it is accessible to make cable connections once the box is installed.

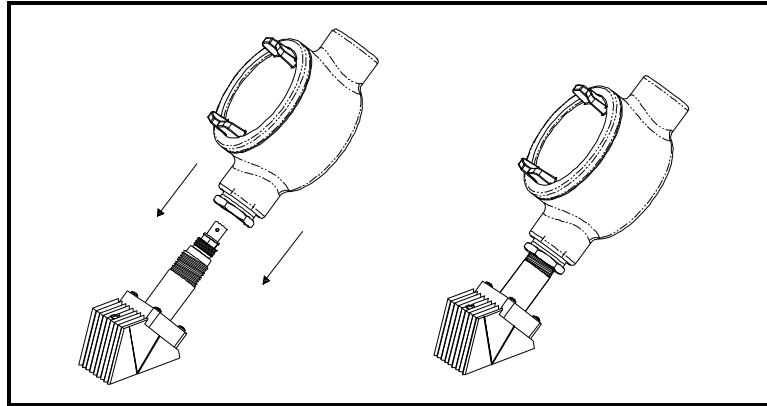

3. Take one of the transducers and apply a thin bead of couplant down the center of its face approximately the size of a toothpaste bead.

**IMPORTANT:** To prevent the loss of couplant, do not slide the transducer with couplant along the surface of the pipe when mounting.

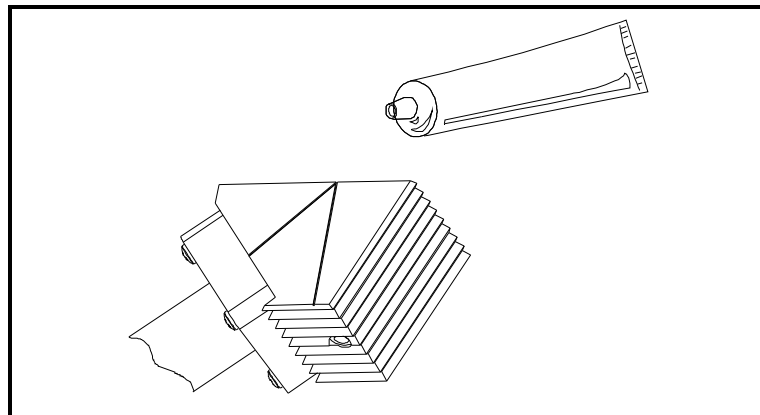

4. Place the transducers in the appropriate blocks. Make sure the transducers are oriented as shown below.

**CAUTION!** To ensure against impact to the transducer face, it must always be mounted flush to the pipe.

**Note:** If the transducer cables are already connected, you must determine the upstream and downstream directions of the pipe and place the transducers into the appropriate blocks.

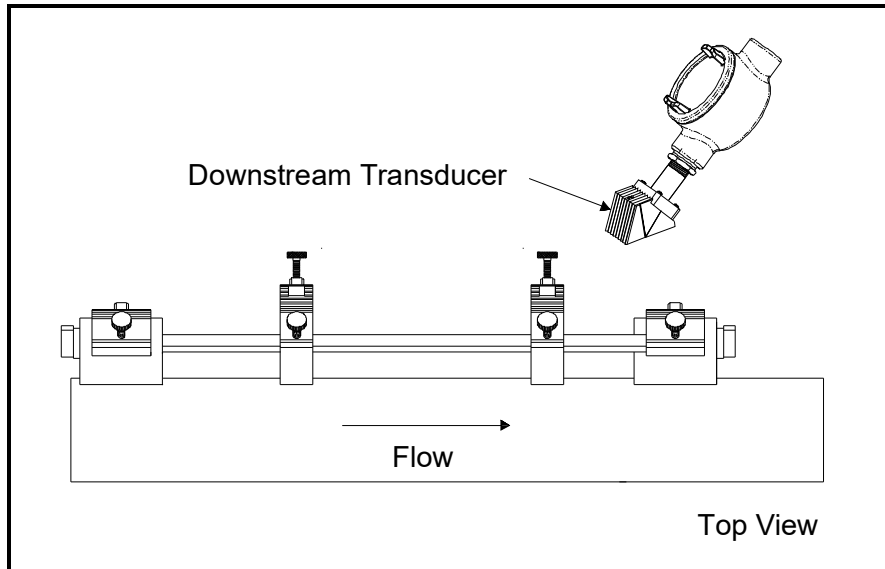

5. Use the pressure bolt to secure the transducer in place. The pressure bolt should fit into the dimple. Hand-tighten enough to hold the transducer in place. Do not overtighten so that the fixture lifts off the pipe.

**WARNING!** Do not tighten the pressure bolt so that the magnet separates from the pipe.

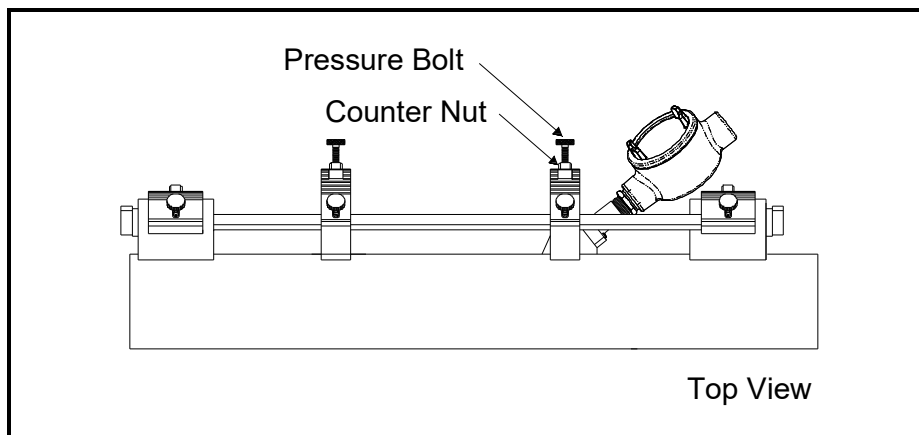

6. Tighten the counter nut on the pressure bolt (see drawing in step 5 on page 36).

**IMPORTANT:** When using the MCF in a pipe location with possible mechanical vibration, the locking nut must be used to secure the position of the pressure bolt on the transducer after the bolt has been hand-tightened into the transducer dimple. For additional resistance to vibration a thread lock compound or a stainless steel washer and lock washer may also be used. These items can be ordered from GE by requesting a "special" clamping fixture and specifying either the thread lock or the washers.

7. Repeat Steps 1 to 6 to mount the other transducer in the remaining block. See Figure 12 for completed installations.

**WARNING!** Before performing the next step make sure the power to the flowmeter electronics is disconnected.

8. Make transducer cable connections as described in the *Installation* chapter of the *Startup Guide*.

**WARNING!** If your fixture is installed at an elevated location, Panametrics recommends securing the fixture with the optional safety chain or a tether/leash to prevent injury if the fixture falls off the pipe.

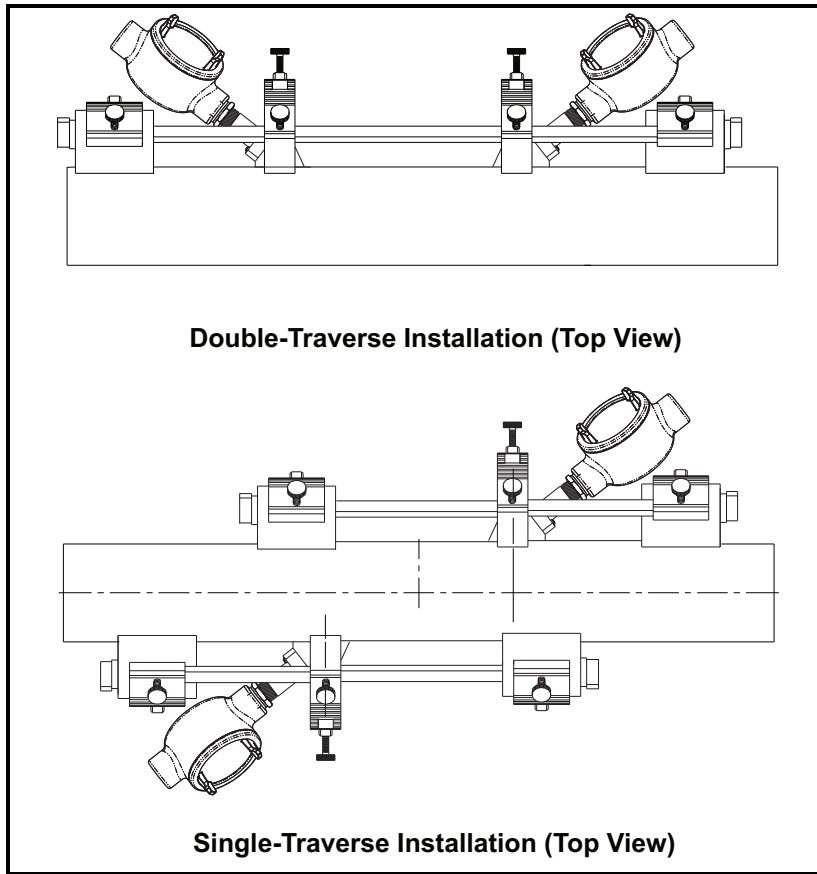

**Figure 12: Completed MCF Installations with Transducers**

**Note:** *If you have mounted the transducers into the MCF properly, the two transducer cable connectors will face away from each other as shown in Figure 12.*

---

## 6 Installing C-PT Transducers for the TransFlection Method

Before making measurements using the TransFlection method, you must install the transducers properly. Like transit time measurement, TransFlection requires two transducers. The transducers are mounted on the pipe using a TransFlection Mode Clamping Fixture (TMCF) that is clamped around the pipe with a chain or strap. Since the TMCF can be used to install transducers up to 180° apart around the pipe, different fixtures are used depending on the placement of the fixture.

Use this guide to properly install the fixture and transducers on your pipe.

### 6.1 Mounting the TransFlection Mode Clamping Fixture - TMCF

The transducers can be mounted up to 180° apart around the circumference of the pipe. The angle between the transducers is dependent on the size of the pipe. Generally, transducers are located opposite each other (180°) on pipes 2 to 4 inches in diameter. For pipes 4 inches in diameter and larger, or on smaller pipes (i.e. 2 to 4 inches in diameter) with heavy concentrations of two-phase liquid present, the transducers are located right next to each other.

Refer to one of the following sections to properly mount the transducers and fixture.

- Mounting the TMCF in <180° Configuration - page 39
- Mounting the TMCF in 180° Configuration - page 42

### 6.1.1 Mounting the TMCF in a <math><180^\circ</math> Configuration

Use the following steps to properly mount and install the transducers in a <math><180^\circ</math> configuration.

1. Familiarize yourself with the components of the TMCF as shown below.

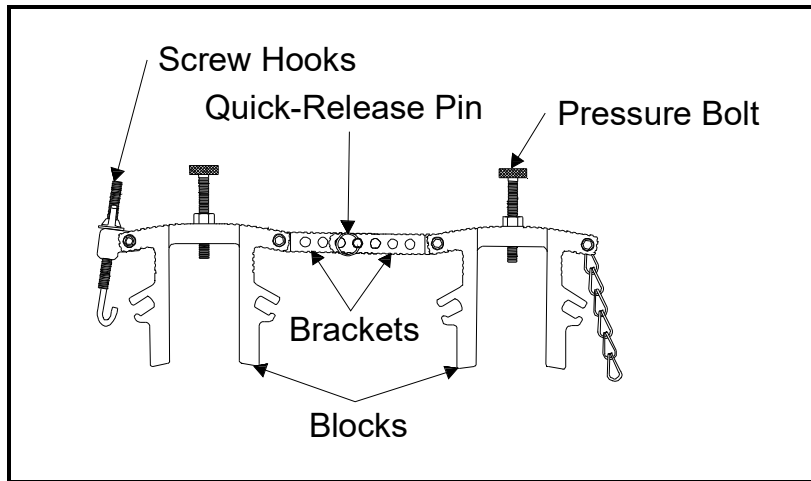

2. Prepare the pipe where you intend to place the TMCF by making sure it is clean and free of loose material. Sanding, though usually not required, may be necessary to take off any high spots. Be careful to preserve the original curvature of the pipe.
3. If not already connected, connect the bracket from each block using the quick-release pin. The distance between the blocks depends on where you are placing them on the pipe. You only need to estimate the distance. If necessary, the distance can be adjusted later.

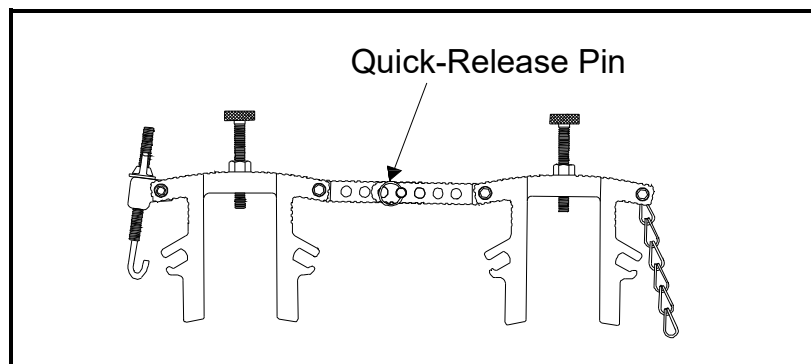

4. Position the fixture with the two blocks in a common axial plane of the pipe, but not on the top or bottom of the pipe.

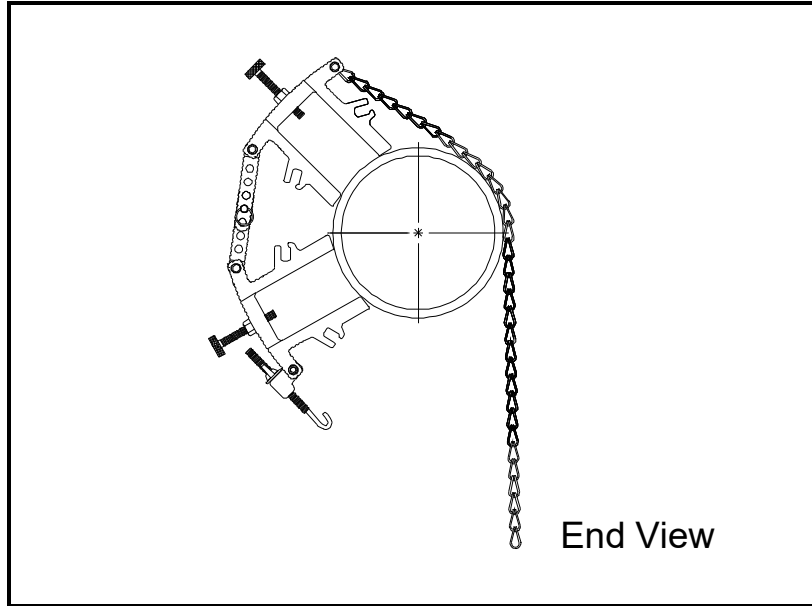

5. Wrap the chains around the pipe and fasten them to the screw hooks on the other block. If necessary, adjust the distance between the blocks.

**Note:** *Make sure the chains are not twisted.*

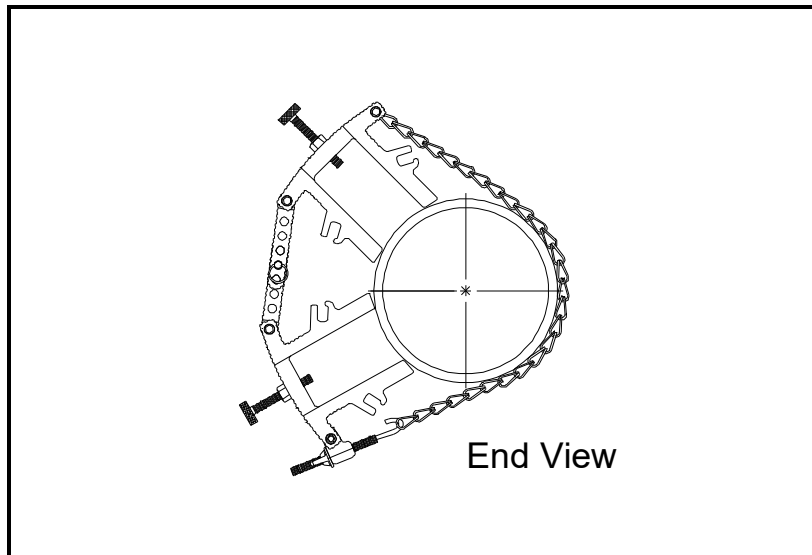



6. Tighten and/or loosen the chains using the screw hooks to fine tune the angle between the blocks. The blocks should fit snugly against the pipe.

**Note:** Make sure the blocks are in a common axial plane so the chains are not slanted. If the chains are slanted, the slack will allow the fixture to move around.

7. Proceed to *Mounting the Transducers into the TransFlexion Mode Clamping Fixture - TMC* on page 35.

Figure 13 shows an example of a completed  $<180^\circ$  installation without transducers.

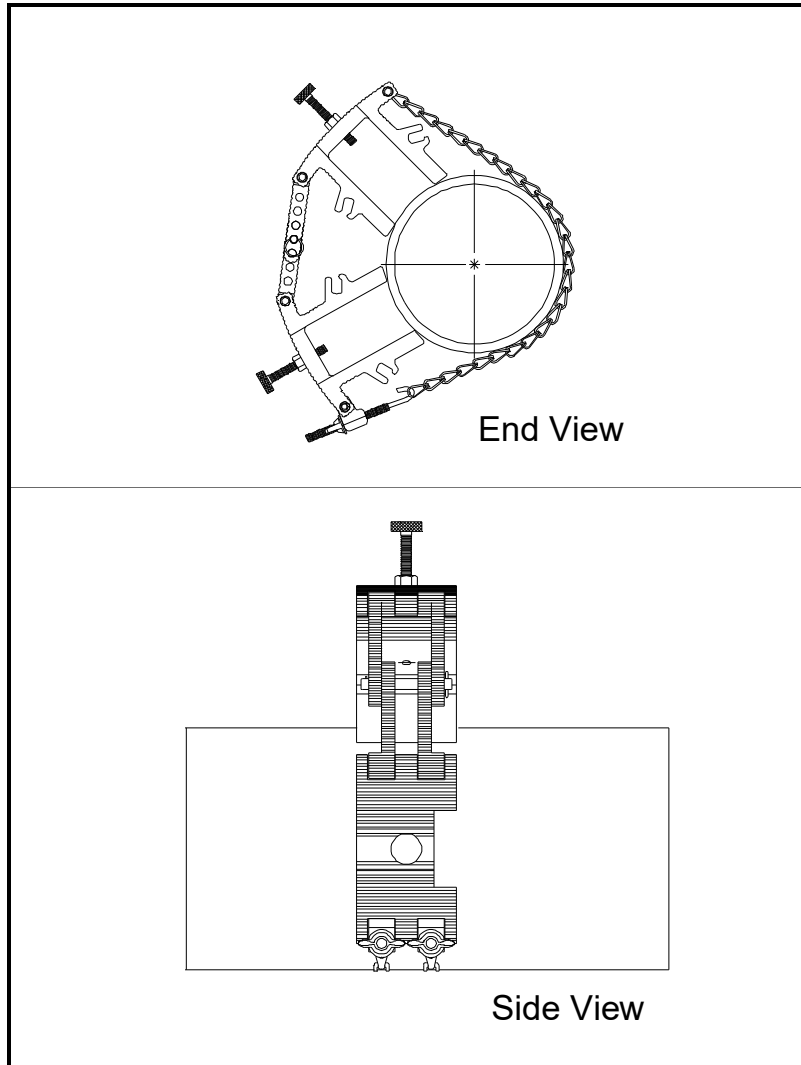
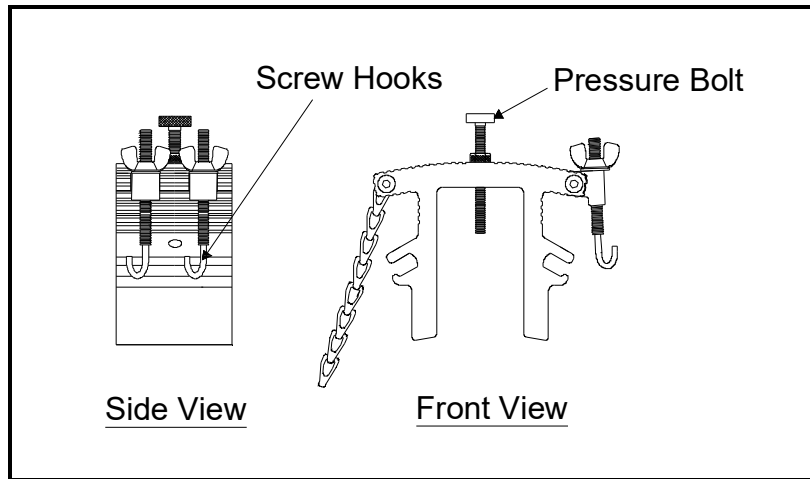

Figure 13: Completed  $<180^\circ$  Installation without Transducers

### 6.1.2 Mounting the TCMF in a 180° Configuration

Use the following steps to properly mount and install the transducers in a 180° configuration.

1. Familiarize yourself with the components of the TCMF as shown below.



2. Prepare the pipe where you intend to place the TCMF by making sure it is clean and free of loose material. Sanding, though usually not required, may be necessary to take off any high spots. Be careful to preserve the original curvature of the pipe.
3. If not already connected, connect the chain from one block to the screw hooks on the other block. The distance between the blocks depends on where you are placing them on the pipe. You only need to estimate the distance. If necessary, the distance can be adjusted later.

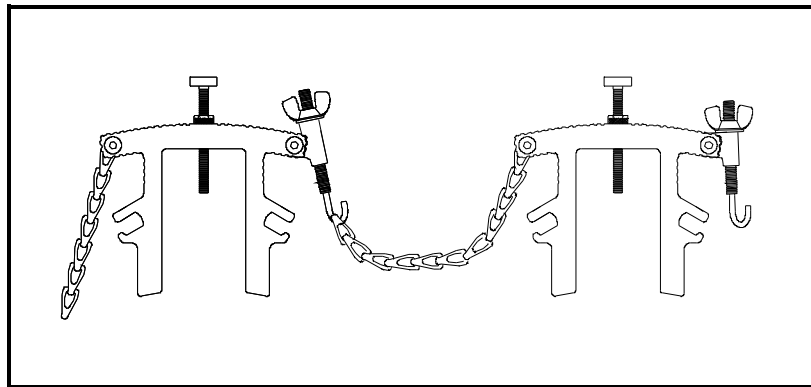

4. Position the blocks in a common plane of the pipe, but not on the top or bottom. The blocks should be opposite each other (180°).

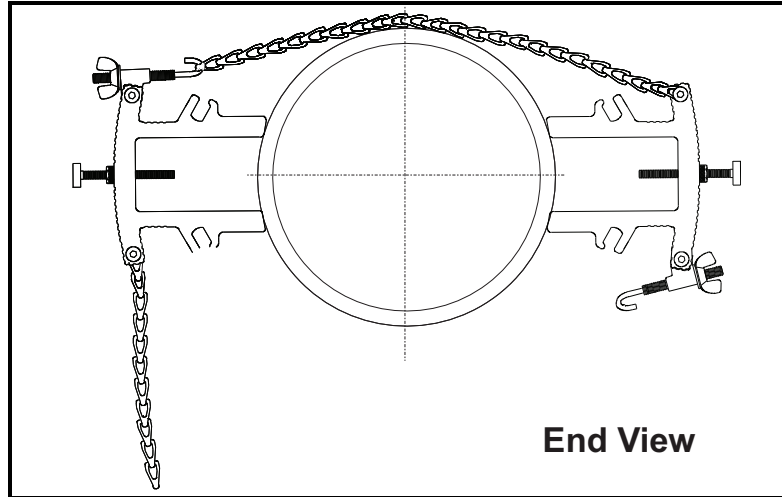

5. Wrap the remaining chains around the pipe and fasten them to the screw hooks on the other block. Make sure the chains on either side of the pipe are approximately the same length.

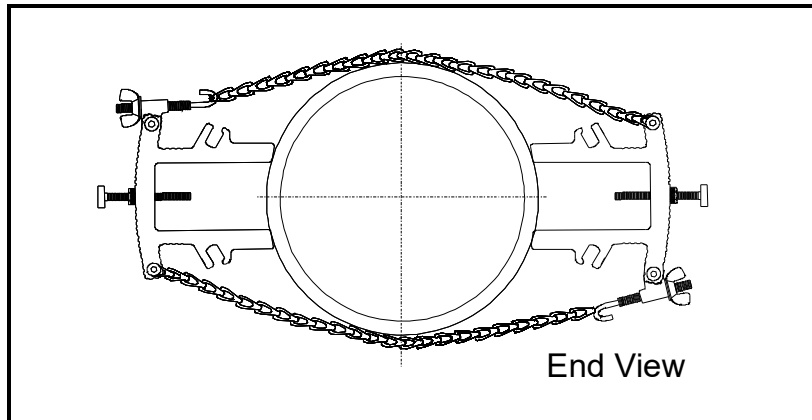

6. Tighten and/or loosen the chains using the screw hooks on both blocks to fine tune the angle between the blocks. Make sure the chains are not twisted or slanted.
7. Proceed to *Mounting the Transducers into the TransFlection Mode Clamping Fixture - TMCF* on page 45.

Figure 14 shows an example of a completed 180° installation without transducers.

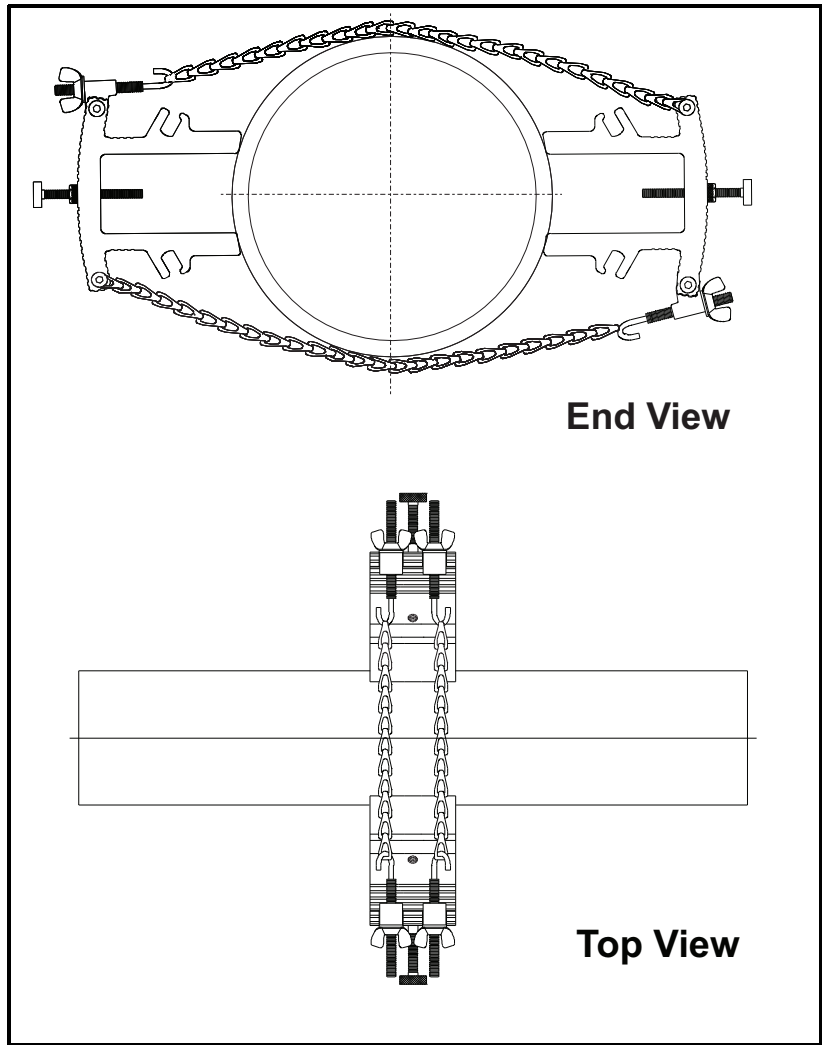

Figure 14: Completed 180° Installation without Transducers

## 6.2 Mounting the Transducers into the TransFlection Mode Clamping Fixture - TMCF

The last step of installation is mounting the transducers into the clamping fixture. C-PT transducers are manufactured with a dimple on top of the transducer body. In addition, there are scribe marks on each side.

Use the following steps to mount transducers:

1. Apply a thread sealant to the transducer threads. A sealant is not required within the US, however, a sealant must be used in European Communities.
2. Before mounting the transducers, thread the junction box onto the end of the transducer with the BNC connector. Ensure that at least five full threads are engaged. Make sure to orient the cover of the junction box so it is accessible to make cable connections once the box is installed.

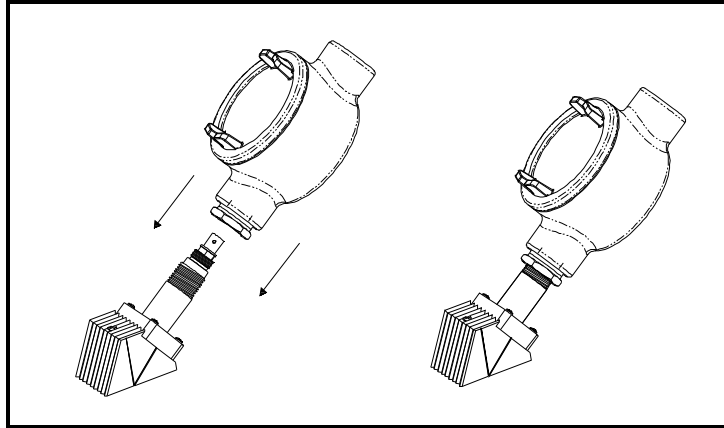

3. Take one of the transducers and apply a thin bead of couplant down the center of its face.

**IMPORTANT:** To prevent the loss of couplant, do not slide the transducer with couplant along the surface of the pipe when mounting.

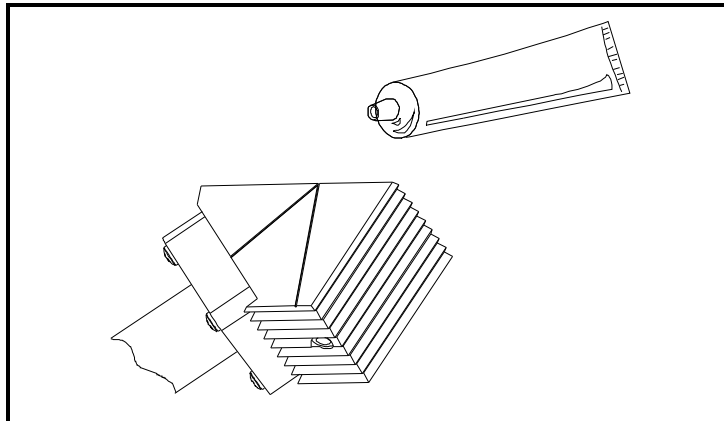

4. Slide the transducer into one of the blocks.

**CAUTION!** To ensure against impact to the transducer face, it must always be mounted flush to the pipe.

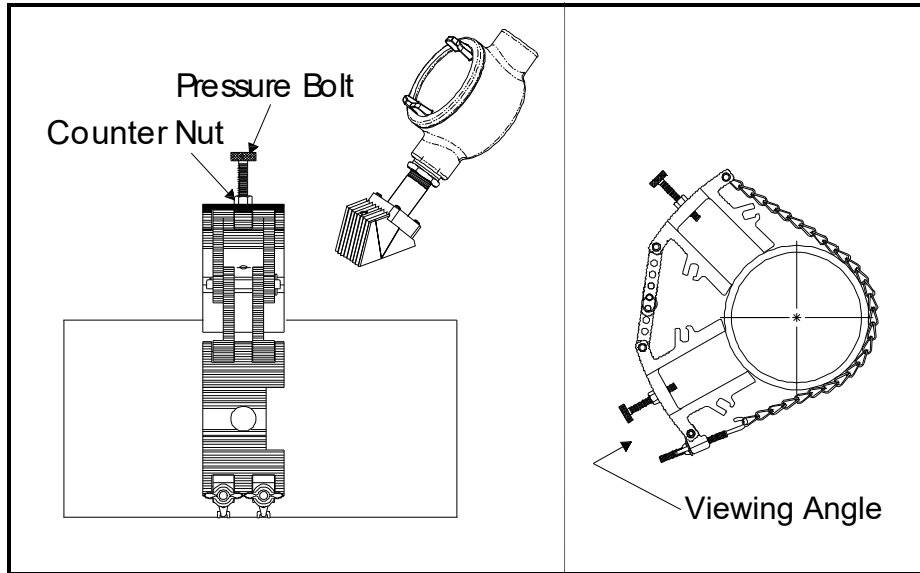

5. Use the pressure bolt to secure the transducer into place. The pressure bolt should fit into the dimple on the top of the transducer. Tighten just enough to hold the transducer in place. DO NOT tighten so much that the block lifts off the pipe.
6. Tighten the counter nut on the pressure bolt (see drawing above).

**IMPORTANT:** When using the TMC in a pipe location with possible mechanical vibration, the locking nut must be used to secure the position of the pressure bolt on the transducer after the bolt has been hand-tightened into the transducer dimple. For additional resistance to vibration a thread lock compound or a stainless steel washer and lock washer may also be used. These items can be ordered from Panametrics by requesting a "special" clamping fixture and specifying either the thread lock or the washers.

7. Repeat steps 1 through 6 to insert the other transducer into the remaining block. Refer to Figure 15 on page 47 and Figure 16 on page 48 for examples of completed installations. When inserting the second transducer, make sure the transducers face the same direction.

**WARNING!** Before performing the next step make sure the power to the flowmeter electronics is disconnected.

8. Make transducer cable connections as described in the *Installation* chapter of the *Startup Guide*.

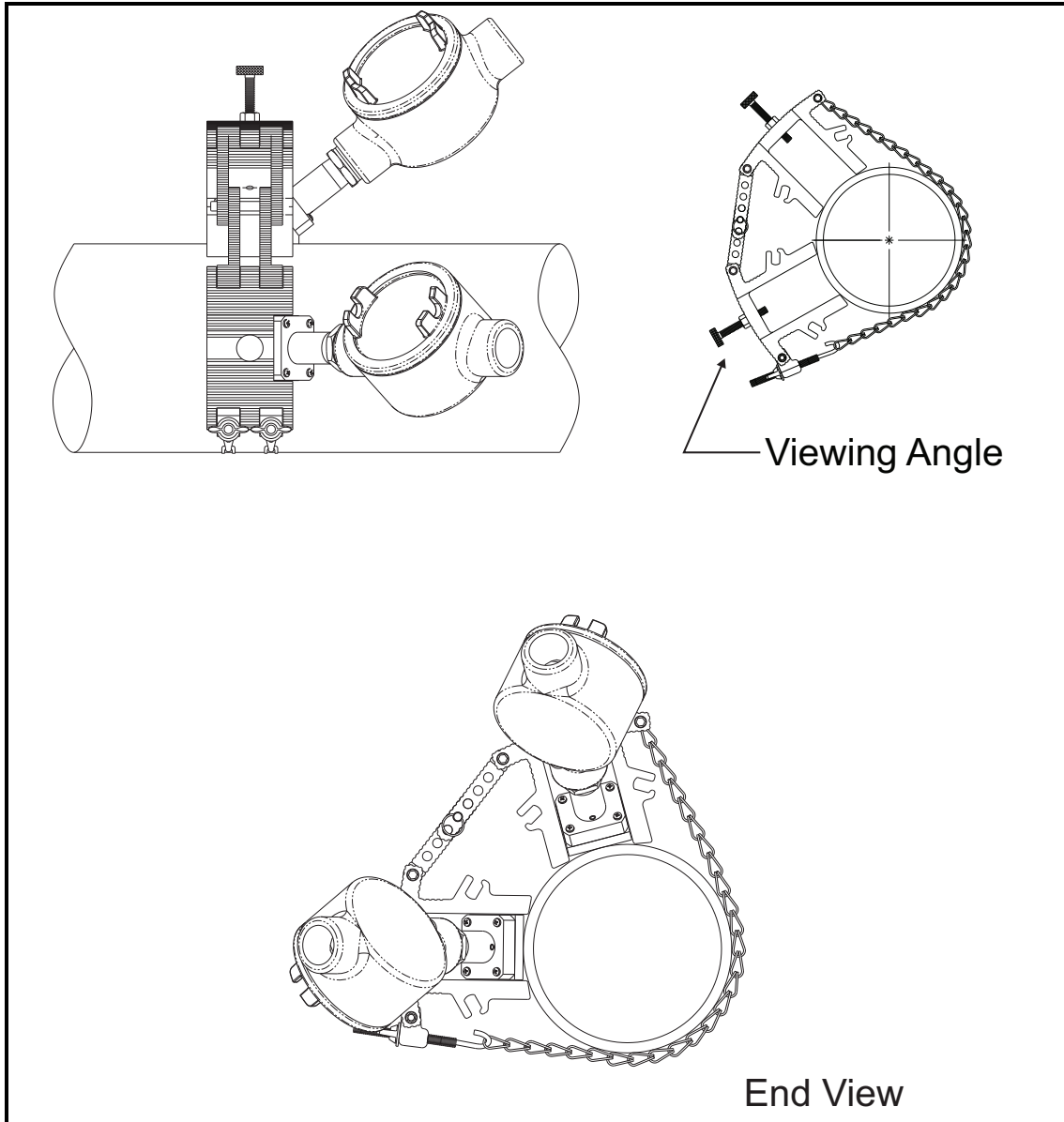

**Figure 15: Examples of Completed TCMF Installations with Transducers in  $<180^\circ$  Configuration**

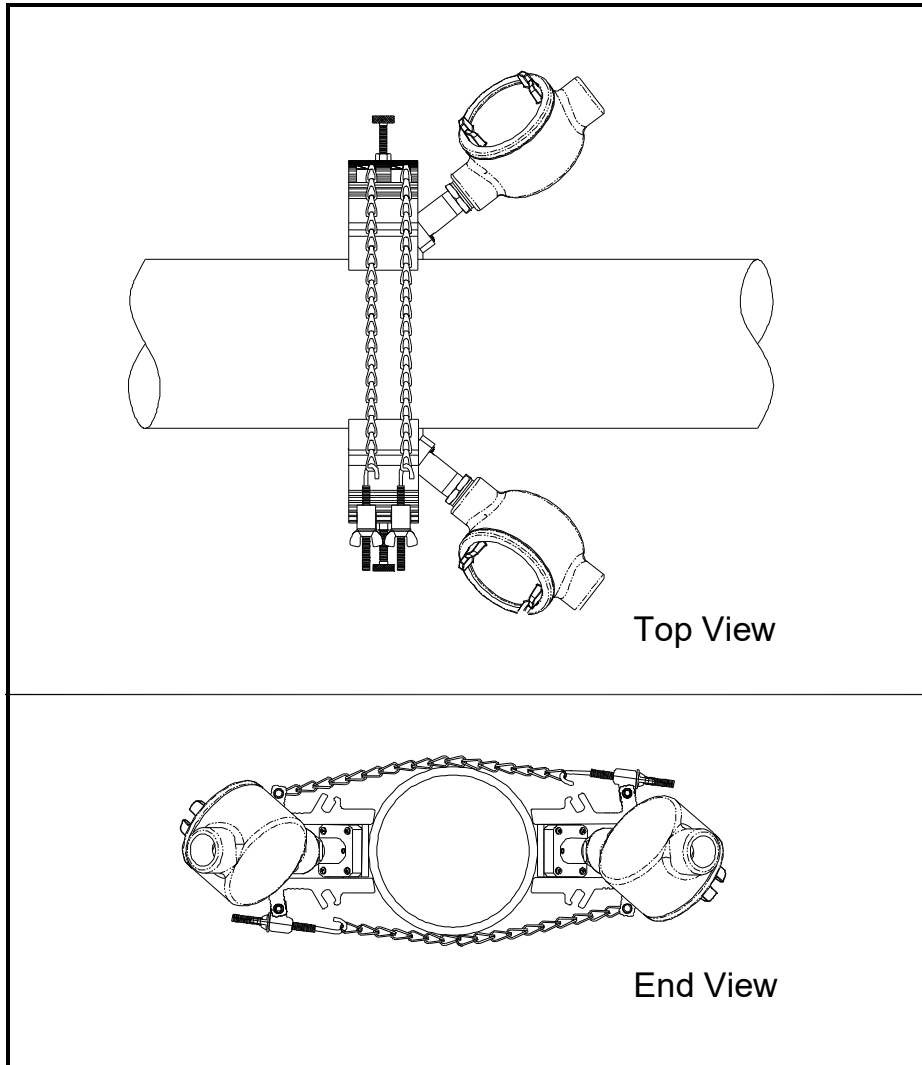

Figure 16: Examples of Completed TMCF Installations with Transducers in 180° Configuration

## 7 Maintaining the C-PT Transducers

Once properly installed into the fixture, the C-PT transducers require no additional adjustments.

If you suspect something is wrong with a transducer or need to replace a transducer, simply loosen the pressure bolt that secures the transducer in place and remove it. If necessary, loosen the counter locking nut with a wrench. To insert a new transducer, refer to the appropriate section in this document.



---

## 8 Specifications

### 8.1 General Specifications

**Designation:**

- C-PT-N Normal Temperature Style
- C-PT-M Medium Temperature Style
- C-PT-H High Temperature Style

**IMPORTANT:** The transducer is protected by a suitable fuse located in the flowmeter electronics. The fuse has a breaking capacity in accordance with the short circuit current of the supply.

**Mounting:**

- Clamp-on

**Material:**

- C-PT cover is 316 Stainless Steel

**Pipe Sizes:**

- 2" to 300" diameter (and larger)

**Pipe Material:**

- All

**Frequency:**

- 200 kHz, 500 kHz, 1.0 MHz, and 2.0 MHz

**Electrical Rating:**

- 200 V peak-to-peak, 5 mA

**Ambient Temperature Range:**

- C-PT-N: -4 to +122°F (-20 to +50°C)
- C-PT-M and -H: -4 to +140°F (-20 to +60°C)

**Process Temperature Range:**

- C-PT-N Normal: -4 to +122°F (-20 to +50°C)
- C-PT-M Medium: -4 to +293°F (-20 to +145°C)
- C-PT-H High: -4 to +363°F (-20 to +184°C)

---

## 8.2 Hazardous Area Certifications

### *North American Certification - Explosionproof:*



C US Class I, Division 1, Group C, D, Class II, Division 1,  
Group E, F, G, Class III.

### *European Certification - Flameproof:*

GE Sensing, 221 Crescent St., Waltham, MA 02453, USA

C-PT

KEMA03ATEX1147X:



1180



II 2 G EEx md IIC T6 - T2

Serial #:

Mfg Date:

C-PT-N:  $-20^{\circ}\text{C} \leq T_{\text{amb}} \leq +50^{\circ}\text{C}$ , 200 V<sub>pp</sub>, 5 mA

C-PT-M, -H:  $-20^{\circ}\text{C} \leq T_{\text{amb}} \leq +60^{\circ}\text{C}$ , 200 V<sub>pp</sub>, 5 mA

Certified Model String:

Ultrasonic Flow Transducer Model CPT-aa-b-c

aa = Frequency: 02 (200KHz), 05 (500KHz), 10 (1MHz)  
or 20 (2MHz).

b = Process Temperature: N (Normal), M (Medium)  
or H (High).

c = Connector Type: B (BNC).

---

## Warranty

Each instrument manufactured by Panametrics is warranted to be free from defects in material and workmanship. Liability under this warranty is limited to restoring the instrument to normal operation or replacing the instrument, at the sole discretion of Panametrics. Fuses and batteries are specifically excluded from any liability. This warranty is effective from the date of delivery to the original purchaser. If Panametrics determines that the equipment was defective, the warranty period is:

- one year from delivery for electronic or mechanical failures
- one year from delivery for sensor shelf life

If Panametrics determines that the equipment was damaged by misuse, improper installation, the use of unauthorized replacement parts, or operating conditions outside the guidelines specified by Panametrics, the repairs are not covered under this warranty.

---

**The warranties set forth herein are exclusive and are in lieu of all other warranties whether statutory, express or implied (including warranties or merchantability and fitness for a particular purpose, and warranties arising from course of dealing or usage or trade).**

---

## Return Policy

If a Panametrics instrument malfunctions within the warranty period, the following procedure must be completed:

1. Notify Panametrics, giving full details of the problem, and provide the model number and serial number of the instrument. If the nature of the problem indicates the need for factory service, Panametrics will issue a RETURN AUTHORIZATION NUMBER (RAN), and shipping instructions for the return of the instrument to a service center will be provided.
2. If Panametrics instructs you to send your instrument to a service center, it must be shipped prepaid to the authorized repair station indicated in the shipping instructions.
3. Upon receipt, Panametrics will evaluate the instrument to determine the cause of the malfunction.

Then, one of the following courses of action will then be taken:

- If the damage is covered under the terms of the warranty, the instrument will be repaired at no cost to the owner and returned.
- If Panametrics determines that the damage is not covered under the terms of the warranty, or if the warranty has expired, an estimate for the cost of the repairs at standard rates will be provided. Upon receipt of the owner's approval to proceed, the instrument will be repaired and returned.

---

[no content intended for this page]

---

We,

**PANAMETRICS, Inc.**  
**1100 Technology Park Drive**  
**Billerica, MA 01821-4111**  
**U.S.A.**

as the manufacturer, declare under our sole responsibility that the product

**Types C-PT-H, C-PT-M, and C-PT-N Ultrasonic Flow Transducers**

to which this document relates, in accordance with the provisions of ATEX Directive 94/9/EC Annex II, meets the following specifications:



**II 2 G EEx md IIC T6-T3**

**KEMA03ATEX1147X 200 V<sub>pp</sub>, 5 mA, -20°C to 60°C (C-PT-H, C-PT-M), -20°C to 50°C (C-PT-N)**

Furthermore, the following additional requirements and specifications apply to the product:

- Having been designed in accordance with EN 50014, EN 50018 and EN50028, the product meets the fault tolerance requirements of electrical apparatus for categories “d” and “m”.
- The product is an electrical apparatus and must be installed in the hazardous area in accordance with the requirements of the EC Type Examination Certificate. The installation must be carried out in accordance with all appropriate international, national and local standard codes and practices and site regulations for flameproof apparatus and in accordance with the instructions contained in the manual. Access to the circuitry must not be made during operation.
- Only trained, competent personnel may install, operate and maintain the equipment.
- The product has been designed so that the protection afforded will not be reduced due to the effects of corrosion of materials, electrical conductivity, impact strength, aging resistance or the effects of temperature variations.
- The product cannot be repaired by the user; it must be replaced by an equivalent certified product. Repairs should only be carried out by the manufacturer or by an approved repairer.
- The product must not be subjected to mechanical or thermal stresses in excess of those permitted in the certification documentation and the instruction manual.
- The product contains no exposed parts which produce surface temperature infrared, electromagnetic ionizing, or non-electrical dangers.
- **Installation Instructions:** The product is provided with a male 1/2” NPT thread. For electrical connection, the product must be mounted to a certified metal enclosure in type of explosion protection flameproof enclosure “d”, the assembly complying with the requirements of EN50018 and providing a degree of protection of IP6X. Measures must be taken to ensure a good bonding connection and to prevent the connection from self-loosening.

---

[no content intended for this page]



## Customer Support Centers

### U.S.A.

The Boston Center  
1100 Technology Park Drive  
Billerica, MA 01821

U.S.A.

Tel: 800 833 9438 (toll-free)  
978 437 1000

E-mail: [mstechsupport@bakerhughes.com](mailto:mstechsupport@bakerhughes.com)

### Ireland

Sensing House  
Shannon Free Zone East  
Shannon, County Clare  
Ireland

Tel: +353 61 61470200

E-mail: [mstechsupport@bakerhughes.com](mailto:mstechsupport@bakerhughes.com)

Copyright 2021 Baker Hughes company.

This material contains one or more registered trademarks of Baker Hughes Company and its subsidiaries in one or more countries. All third-party product and company names are trademarks of their respective holders.

916-074 B

**Baker Hughes** 