

Signet 8860 Two-Channel Conductivity Controller

Member of the ProcessPro® Family of Instruments



Features

- Meets USP requirements for measuring raw conductivity, USP alarm mode
- Dual sensor input
- AC or DC powered
- Display and/or control: μ S, mS, PPM or PPB (TDS), k Ω , M Ω , % rejection, difference, ratio, °C or °F
- Three fully scaleable 4 to 20 mA outputs
- Two open collector outputs
- Four programmable relays
- Time delay relay function
- Proportional pulse control capability
- Compatible with ALL Signet conductivity electrodes
- Programmable temperature compensation
- NEMA 4X/IP65

Description

The Signet 8860 Two-Channel Conductivity Controller is packed with a set of features and capabilities ideal for the real needs of water treatment applications. It accommodates two separate and independent input sources and can be powered with AC or 24VDC. The 8860 programs via a simple and intuitive menu system. The unit can also be programmed to measure a raw conductivity value by turning off the temperature compensation mode, hence meeting USP requirements.

To control the process, the 8860 is equipped with four dry contact relays and three 4 to 20mA output loops. Calculated measurement include Difference, Ratio or % Rejection. Two of the relays may be converted into open collector outputs with the flip of a switch. Operating modes for the relays and open collector outputs are high, or low alarm, pulse, or special USP alarm mode. The 8860 is offered with a NEMA 4X/IP65 front panel with a self-healing window in a 1/4 DIN package for easy panel installation.

Application

- RO/DI System Control
- Demineralizer Regeneration and Rinse
- Scrubber, Cooling Tower & Boiler Protection
- Chemical Concentration
- Rinse Tank Water Quality
- Desalination
- Leak Detection
- Aquatic Animal Life Support Systems
- Aquaculture
- Environmental Studies

System Overview

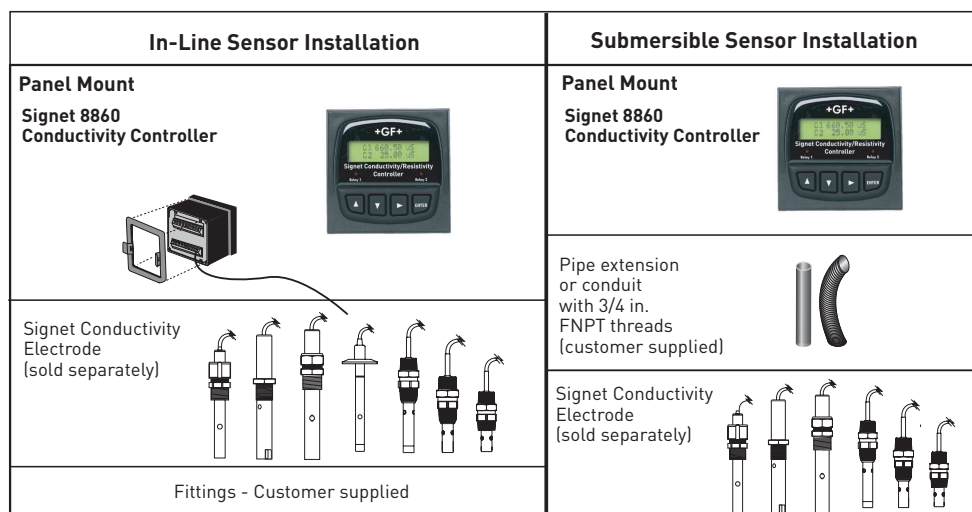

Note: Submersible installation not applicable for Sanitary Conductivity Electrode.



Dimensions

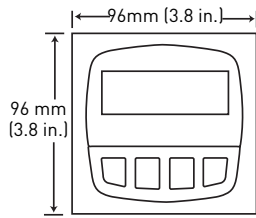

Front View

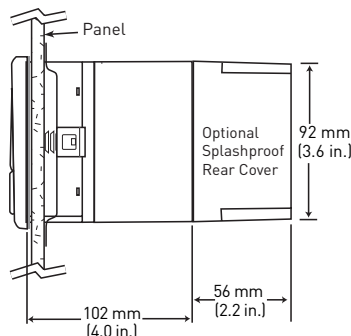

Side View

Specifications

General

Compatible Electrodes:

All Signet conductivity electrodes

Operating Range:

- Conductivity: 0.055 to 400,000 $\mu\text{S}/\text{cm}$
- Resistivity: 10 $\text{K}\Omega\cdot\text{cm}$ to 18.2 $\text{M}\Omega\cdot\text{cm}$ (0.055 to 100 $\mu\text{S}/\text{cm}$)
- TDS: 0.001 to 999999 ppm or ppb (display limit)
- Temperature: PT 1000: -25°C to 120°C (-13°F to 248°F)

Accuracy:

- Conductivity/Resistivity: $\pm 2\%$ of reading
- Temperature: $\pm 0.5^\circ\text{C}$

Materials

- Case: PBT
- Window: Polyurethane coated polycarbonate
- Keypad: Sealed 4-key silicone rubber

Electrical

Power Requirements

- 3-8860-AC: 100 to 240 VAC $\pm 10\%$, 50-60 Hz, 20VA
- 3-8860: 11 to 24 VDC $\pm 10\%$, reg., 0.5A max.

Display: Alphanumeric 2 x 16 LCD
 Contrast: User selected, 5 levels
 Update rate: 1.5 seconds

Current outputs

- [3 each] 4 to 20 mA, isolated, passive, fully adjustable and reversible
- Max. loop impedance:
 150 Ω @ 12 V
 450 Ω @ 18 V
 750 Ω @ 24 V
- Update rate: Approx. 100 mS
- Accuracy: ± 0.03 mA @ 25°C, 24 VDC

Electrical (continued)

Open-collector outputs:

- [2 each] Isolated, 50 mA sink or source, 30 VDC max. with pull-up resistor
- Operational Settings:
 Hi, Lo, USP, Pulse, Off
- Hysteresis: User adjustable
- Time Delay: 0 to 6400 seconds
- Maximum Pulse Rate: 400 pulses/minute

Alarm Contacts: (up to 4 each) SPDT Relays

- Max. voltage ratings:
 5 A @ 30 VDC or 5 A @ 250 VAC
- Operational Settings:
 Hi, Lo, USP, Pulse, Off
- Hysteresis: User adjustable
- Time Delay: 0 to 6400 seconds
- Maximum Pulse Rate: 400 pulses/minute

Environmental

Enclosure Rating: NEMA 4X/IP65 front

Ambient operating temperature:
 -10°C to 55°C (14°F to 131°F)

Storage temperature:
 15°C to 80°C (5°F to 176°F)

Relative humidity:
 0 to 95%, non-condensing

Max. Altitude: 2,000m (6,560 ft.)

Shipping Weight:

- 8860-AC: Approx. 0.581 kg (1.3 lbs.)
- 8860: Approx. 0.544 kg (1.2 lbs.)

Standards and Approvals

- CE, UL
- Immunity: EN50082-2
- Emissions: EN55011
- Safety: EN61010
- Manufactured under ISO 9001:2000 for Quality and ISO 14001:2004 for Environmental Management

Conductivity/
Resistivity

Model 8860

Ordering Notes:

- 1) An optional splashproof rear cover can be ordered separately if needed.
- 2) Use the heavy duty wall mount bracket to mount instrument on a wall
- 3) Order RC filter kits to protect relays from voltage spikes.

Please refer to Wiring, Installation and Accessories sections for more information.

Ordering Information

Instrument Part Number	
3-8860	Two-channel Conductivity Controller with three 4 to 20 mA outputs and 4 relays or 2 relays with 2 open collectors (switch selectable)
↓	Power - Choose one
	- 11 to 24 VDC
	-AC 100 to 240 VAC
3-8860	-AC Example Part Number

Mfr. Part No.	Code
3-8860	159 000 677
3-8860-AC	159 000 678

Accessories and Replacement Parts

Mfr. Part No.	Code	Description
Mounting		
3-8050.395	159 000 186	Splashproof rear cover
3-8050.392	159 000 640	Model 200 Retrofit Adapter
3-5000.399	198 840 224	5 x 5 in. adapter plate for Signet retrofit
3-0000.596	159 000 641	Heavy duty wall mount bracket
3-5000.598	198 840 225	Surface mount bracket
Liquid Tight Connectors		
3-9000.392	159 000 368	Liquid-tight connector kit for rear cover (3 connectors)
3-9000.392-1	159 000 839	Liquid-tight connector (1 set), NPT
3-9000.392-2	159 000 841	Liquid-tight connector (1 set), PG 13.5
Other		
3-8050.396	159 000 617	RC filter kit (for relay use), 2 per kit
3-2830	159 000 628	Conductivity Certification Tool (see individual product page for more information)