

# Rosemount™ 8750W Magnetic Flowmeter System

for Utility, Water, and Wastewater Applications



**NOTICE**

This document provides basic installation guidelines for the Rosemount 8750W Magnetic Flowmeter Platform. For comprehensive instructions for detailed configuration, diagnostics, maintenance, service, installation, or troubleshooting refer to the Rosemount 8750W Reference Manual (document number 00809-0300-4750). The manual and Quick Start Guide are also available electronically on [EmersonProcess.com/Rosemount](http://EmersonProcess.com/Rosemount).

**⚠ WARNING****Failure to follow these installation guidelines could result in death or serious injury.**

- Installation and servicing instructions are for use by qualified personnel only. Do not perform any servicing other than that contained in the operating instructions, unless qualified.
- Verify the installation is done safely and is consistent with the operating environment.
- Ensure the device certification and installation techniques are suitable for the installation environment.
- Explosion hazard. Do not disconnect equipment when a flammable or combustible atmosphere is present.
- To prevent ignition of flammable or combustible atmospheres, disconnect power before servicing circuits.
- Do not connect a Rosemount 8750W Transmitter to a non-Rosemount sensor that is located in an explosive atmosphere.
- Follow national, local, and plant standards to properly earth ground the transmitter and sensor. The earth ground must be separate from the process reference ground.
- Rosemount Magnetic Flowmeters ordered with non-standard paint options or non-metallic labels may be subject to electrostatic discharge. To avoid electrostatic charge build-up, do not rub the flowmeter with a dry cloth or clean with solvents.

**NOTICE**

- The sensor liner is vulnerable to handling damage. Never place anything through the sensor for the purpose of lifting or gaining leverage. Liner damage may render the sensor inoperable.
- Metallic or spiral-wound gaskets should not be used as they will damage the liner face of the sensor. If frequent removal is anticipated, take precautions to protect the liner ends. Short spool pieces attached to the sensor ends are often used for protection.
- Correct flange bolt tightening is crucial for proper sensor operation and life. All bolts must be tightened in the proper sequence to the specified torque specifications. Failure to observe these instructions could result in severe damage to the sensor lining and possible sensor replacement.
- In cases where high voltage/high current are present near the meter installation, ensure proper protection methods are followed to prevent stray voltage/current from passing through the meter. Failure to adequately protect the meter could result in damage to the transmitter and lead to meter failure.
- Completely remove all electrical connections from both sensor and transmitter prior to welding on the pipe. For maximum protection of the sensor, consider removing it from the pipeline.

**Contents**

Transmitter installation .....	3	Wiring the transmitter .....	18
Handling and lifting .....	8	Basic configuration .....	31
Mounting .....	9	Product Certifications .....	36
Sensor installation .....	11	Installation and wiring drawings .....	48
Process reference connection .....	16		

# 1.0 Transmitter installation

Installation of the Rosemount Magnetic Flowmeter Transmitter includes both detailed mechanical and electrical installation procedures.

Before installing the Rosemount 8750W, there are several pre-installation steps that should be completed to make the installation process easier:

- Identify the options and configurations that apply to your application.
- Set the hardware switches if necessary.
- Consider mechanical, electrical, and environmental requirements.

## 1.1 Identify options and configurations

The typical installation of the Rosemount 8750W includes a device power connection, a 4–20mA output connection, and sensor coil and electrode connections. Other applications may require one or more of the following configurations or options:

- Pulse output
- Discrete input/discrete output
- HART® Multidrop Configuration

### Hardware switches

The Rosemount 8750W electronics stack is equipped with user-selectable hardware switches. These switches set the Alarm mode, Internal/external analog power, Internal/external pulse power<sup>(1)</sup>, and Transmitter security. The standard configuration for these switches when shipped from the factory are as follows:

**Table 1. Standard Switch Configuration**

Setting	Standard switch configuration
Alarm mode	High
Internal/external analog power	Internal
Internal/external pulse power <sup>(1)</sup>	External
Transmitter security	Off

In most cases, it will not be necessary to change the setting of the hardware switches. If the switch settings need to be changed, follow the steps outlined in the “Changing hardware switch settings” section of the Rosemount 8750W Reference Manual.

### NOTICE

To prevent switch damage, use a non-metallic tool to move switch positions.

Be sure to identify any additional options and configurations that apply to the installation. Keep a list of these options for consideration during the installation and configuration procedures.

1. Rosemount 8750W Field Mount Transmitter only.

## 1.2 Mechanical considerations

The mounting site for the Rosemount 8750W should provide enough room for secure mounting, easy access to conduit entries, full opening of the transmitter covers, and easy readability of the LOI screen if equipped.

For remote field mount transmitter installations, a mounting bracket is provided for use on a 2-in. pipe or a flat surface (see [Figure 1](#)).

### **NOTICE**

If the transmitter is mounted separately from the sensor, it may not be subject to limitations that might apply to the sensor.

### **Rotate integral mount transmitter housing**

The transmitter housing can be rotated on the sensor in 90° increments by removing the four mounting screws on the bottom of the housing. Do not rotate the housing more than 180° in any one direction. Prior to tightening, be sure the mating surfaces are clean, the O-ring is seated in the groove, and there is no gap between the housing and the sensor.

**Figure 1. Rosemount 8750W Field Mount Transmitter**

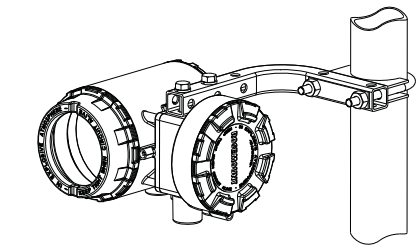
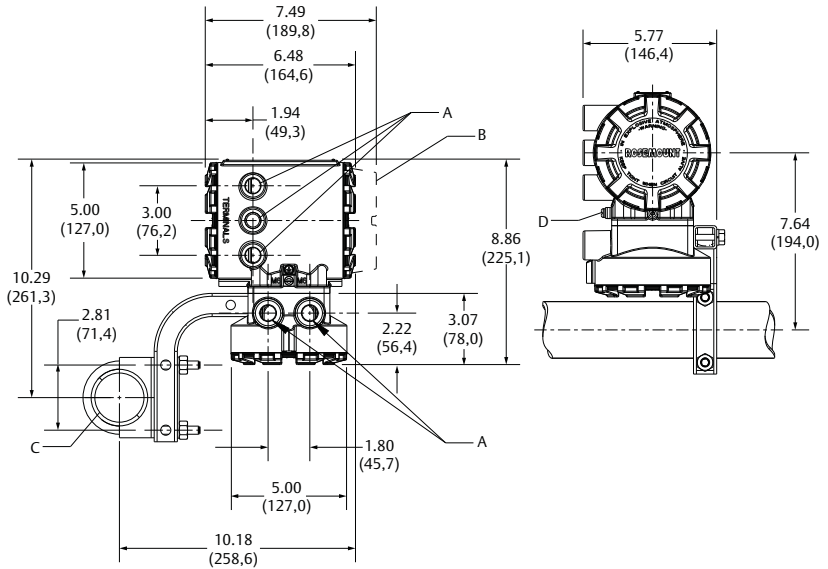

- A. 1/2-in.-14 NPT conduit entry
- B. LOI cover
- C. 2-in. pipe bracket
- D. Ground lug

Dimensions are in inches (millimeters).

**Figure 2. Rosemount 8750W Integral Field Mount Transmitter**

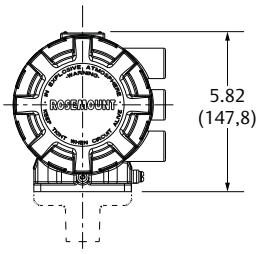

**Figure 3. Rosemount 8750W Wall Mount Transmitter with Standard Cover**

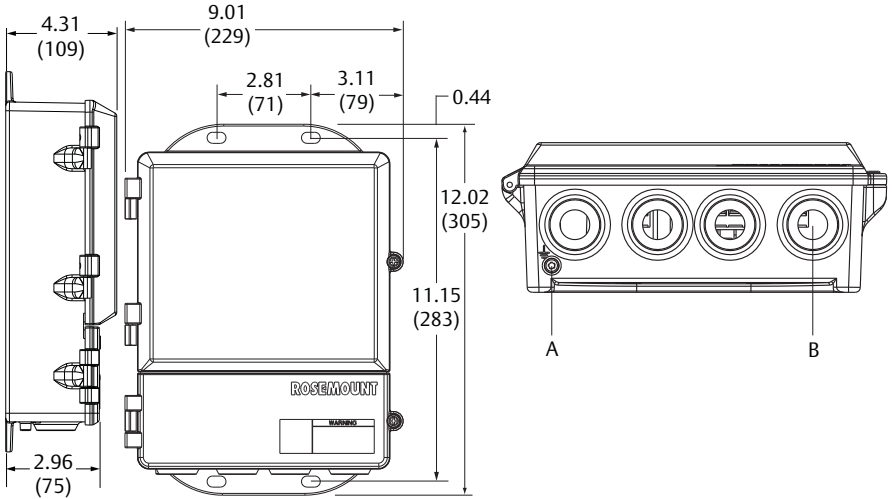

- A. Ground lug
- B. 1/2-in.-14 NPT or M20 conduit entry

Dimensions in inches (millimeters).

**Figure 4. Rosemount 8750W Wall Mount Transmitter with LOI Cover**

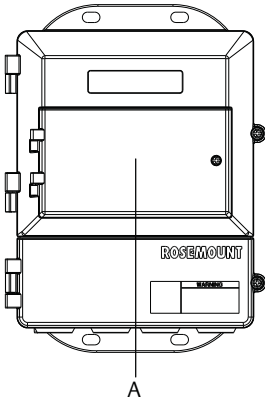

- A. LOI keypad cover

**NOTICE**

Default conduit entries are 1/2-in. NPT. If an alternate thread connection is required, thread adapters must be used.

## 1.3 Electrical considerations

Before making any electrical connections to the Rosemount 8750W, consider national, local and plant electrical installation requirements. Be sure to have the proper power supply, conduit, and other accessories necessary to comply with these standards.

Both remotely and integrally mounted transmitters require external power so there must be access to a suitable power source.

**Table 2. Electrical Data**

<b>Field mount transmitter</b>	
Power input	90–250VAC, 0.45A, 40VA 12–42VDC, 1.2A, 15W
Pulsed circuit	Internally powered (Active): Outputs up to 12VDC, 12.1mA, 73mW Externally powered (Passive): Input up to 28VDC, 100mA, 1W
4-20mA output circuit	Internally Powered (Active): Outputs up to 25mA, 24VDC, 600mW Externally Powered (Passive): Input up to 25mA, 30VDC, 750mW
Coil excitation output	500mA, 40V max, 9W max
<b>Wall mount transmitter</b>	
Power input	90–250VAC, 0.28A, 40VA 12–42VDC, 1A, 15W
Pulsed circuit	Externally powered (Passive): 5–24VDC, up to 2W
4-20mA output circuit	Internally powered (Active): Outputs up to 25mA, 30VDC Externally powered (Passive): Input up to 25mA, 10–30VDC
Coil excitation output	500mA, 40V max, 9W max
<b>Sensor<sup>(1)</sup></b>	
Coil excitation input	500mA, 40V max, 20W max
Electrode circuit	5V, 200uA, 1mW

1. Provided by the transmitter.

## 1.4 Environmental considerations

To ensure maximum transmitter life, avoid extreme temperatures and excessive vibration. Typical problem areas:

- high-vibration lines with integrally mounted transmitters
- tropical/desert installations in direct sunlight
- outdoor installations in arctic climates

Remote-mounted transmitters may be installed in the control room to protect the electronics from the harsh environment and to provide easy access for configuration or service.

## 2.0 Handling and lifting

- Handle all parts carefully to prevent damage. Whenever possible, transport the system to the installation site in the original shipping container.
- PTFE-lined sensors are shipped with end covers that protect it from both mechanical damage and normal unrestrained distortion. Remove the end covers just before installation.
- Keep the shipping plugs in the conduit connections until you are ready to connect and seal them.
- The sensor should be supported by the pipeline. Pipe supports are recommended on both the inlet and outlet sides of the sensor pipeline. There should be no additional support attached to the sensor.
- Additional safety recommendations for mechanical handling:
  - Use proper PPE (Personal Protection Equipment) should include safety glasses and steel toed shoes).
  - Do not drop the device from any height.
- Do not lift the meter by holding the electronics housing or junction box. The sensor liner is vulnerable to handling damage. Never place anything through the sensor for the purpose of lifting or gaining leverage. Liner damage can render the sensor useless.
- If provided, use the lifting lugs on each flange to handle the Magnetic Flowmeter when it is transported and lowered into place at the installation site. If lifting lugs are not provided, the Magnetic Flowmeter must be supported with a lifting sling on each side of the housing.
  - Flanged sensors 3-in. through 48-in. come with lifting lugs.
  - Wafer sensors do not come with lifting lugs.

**Figure 5. Support for Handling and Lifting**

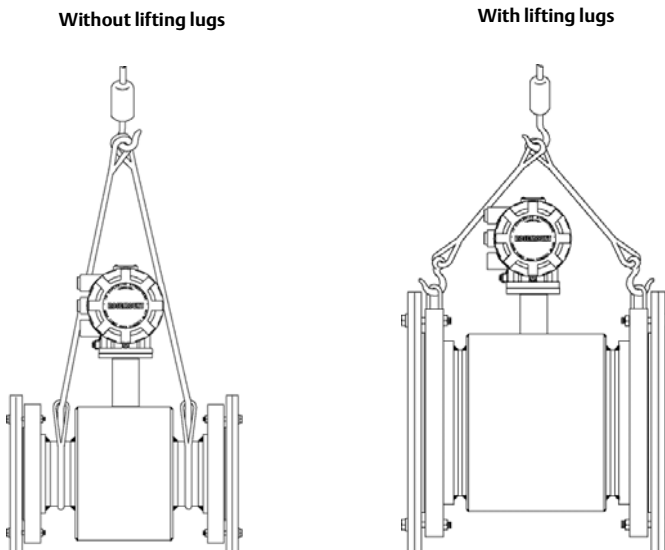



## 3.0 Mounting

### 3.1 Upstream/downstream piping

To ensure specified accuracy over widely varying process conditions, install the sensor with a minimum of five straight pipe diameters upstream and two pipe diameters downstream from the electrode plane (see [Figure 6](#)).

**Figure 6. Upstream and Downstream Straight Pipe Diameters**

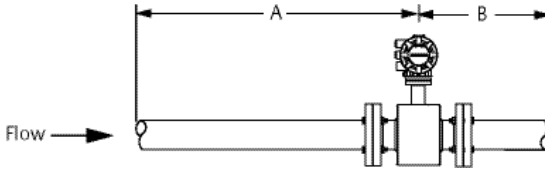

- A. Five pipe diameters
- B. Two pipe diameters

Installations with reduced upstream and downstream straight runs are possible. In reduced straight run installations, the meter may not meet absolute accuracy specifications. Reported flow rates will still be highly repeatable.

### 3.2 Flow direction

The sensor should be mounted so the arrow points in the direction of flow. See [Figure 7](#).

**Figure 7. Flow Direction Arrow**

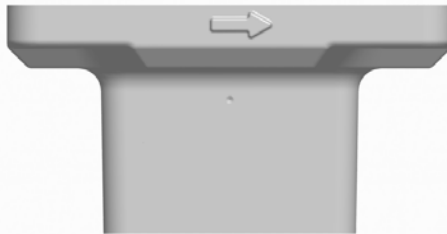

### 3.3 Sensor location

The sensor should be installed in a location that ensures it remains full during operation. Vertical installation with upward process fluid flow keeps the cross-sectional area full, regardless of flow rate. Horizontal installation should be restricted to low piping sections that are normally full.

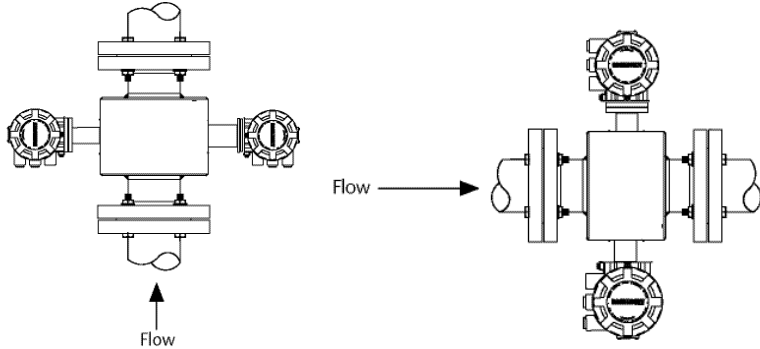
**Figure 8. Sensor Orientation**

### 3.4 Electrode orientation

The electrodes in the sensor are properly oriented when the two measurement electrodes are in the 3 and 9 o'clock positions or within 45° from the horizontal, as shown on the left of Figure 9. Avoid any mounting orientation that positions the top of the sensor at 90° from the vertical position as shown on the right of Figure 9.

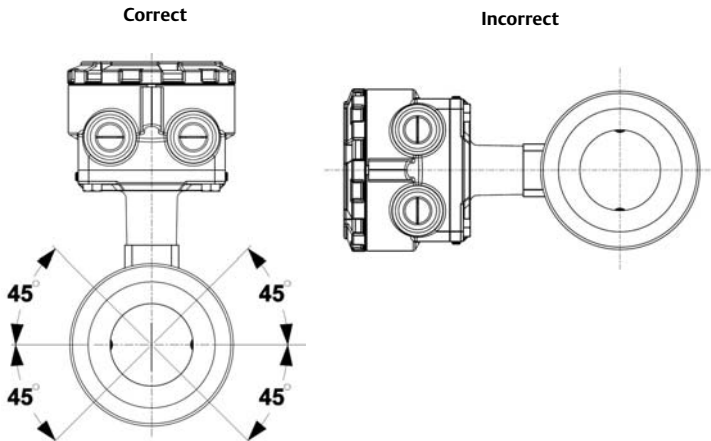
**Figure 9. Mounting Position**

## 4.0 Sensor installation

### 4.1 Gaskets

The sensor requires a gasket at each process connection. The gasket material must be compatible with the process fluid and operating conditions. Gaskets are required on each side of a grounding ring (see [Figure 10](#)). All other applications (including sensors or a grounding electrode) require only one gasket on each process connection.

#### NOTICE

Metallic or spiral-wound gaskets should not be used as they will damage the liner face of the sensor.

**Figure 10. Flanged Gasket Placement**

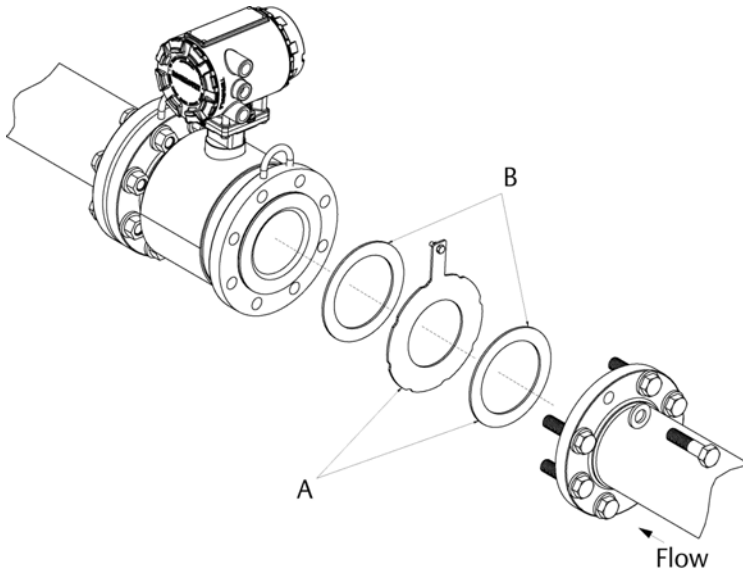

A. Grounding ring and gasket (optional)

B. Customer-supplied gasket

## 4.2 Flange bolts

### Note

Do not bolt one side at a time. Tighten both sides simultaneously. Example:

1. Snug upstream.
2. Snug downstream.
3. Tighten upstream.
4. Tighten downstream.

Do not snug and tighten the upstream side and then snug and tighten the downstream side.

Failure to alternate between the upstream and downstream flanges when tightening bolts may result in liner damage.

Suggested torque values by sensor line size and liner type are listed in [Table 4](#) for ASME B16.5 flanges, [Table 5](#) for EN flanges, and [Table 6](#) and [Table 7](#) for AWWA and EN flanges for line sizes 30-in. (750 mm) to 48-in. (1300 mm). Consult your local Emerson™ Process Management representative if the flange rating of the sensor is not listed. Tighten flange bolts on the upstream side of the sensor in the incremental sequence shown in [Figure 11](#) to 20 percent of the suggested torque values. Repeat the process on the downstream side of the sensor. For sensors with more or less flange bolts, tighten the bolts in a similar crosswise sequence. Repeat this entire tightening sequence at 40, 60, 80, and 100% of the suggested torque values.

If leakage occurs at the suggested torque values, the bolts can be tightened in additional 10% increments until the joint stops leaking, or until the measured torque value reaches the maximum torque value of the bolts. Practical consideration for the integrity of the liner often leads the user to distinct torque values to stop leakage due to the unique combinations of flanges, bolts, gaskets, and sensor liner material.

Check for leaks at the flanges after tightening the bolts. Failure to use the correct tightening methods can result in severe damage. While under pressure, sensor materials may deform over time and require a second tightening 24 hours after the initial installation.

**Figure 11. Flange Bolt Torquing Sequence**

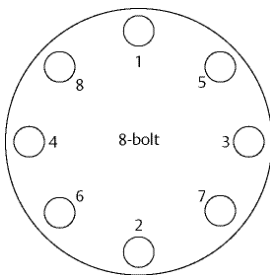

Prior to installation, identify the lining material of the flow sensor to ensure the suggested torque values are applied.

**Table 3. Lining Material**

Fluoropolymer liners	Resilient liners
T - PTFE	P - Polyurethane
	N - Neoprene

**Table 4. Flange Bolt Torque and Load Specifications for 8750W (ASME)**

Size code	Line size	Fluoropolymer liners		Resilient liners	
		Class 150 (pound-feet)	Class 300 (pound-feet)	Class 150 (pound-feet)	Class 300 (pound-feet)
005	0.5-in. (15 mm)	8	8	N/A	N/A
010	1-in. (25 mm)	8	12	N/A	N/A
015	1.5-in. (40 mm)	13	25	7	18
020	2-in. (50 mm)	19	17	14	11
025	2.5-in. (65 mm)	22	24	17	16
030	3-in. (80 mm)	34	35	23	23
040	4-in. (100 mm)	26	50	17	32
050	5-in. (125 mm)	36	60	25	35
060	6-in. (150 mm)	45	50	30	37
080	8-in. (200 mm)	60	82	42	55
100	10-in. (250 mm)	55	80	40	70
120	12-in. (300 mm)	65	125	55	105
140	14-in. (350 mm)	85	110	70	95
160	16-in. (400 mm)	85	160	65	140
180	18-in. (450 mm)	120	170	95	150
200	20-in. (500 mm)	110	175	90	150
240	24-in. (600 mm)	165	280	140	250

**Table 5. Flange Bolt Torque and Load Specifications for 8750W (EN 1092-1)**

Size code	Line size	Fluoropolymer liners			
		PN10 (Newton-meter)	PN 16 (Newton-meter)	PN 25 (Newton-meter)	PN 40 (Newton-meter)
005	0.5-in. (15 mm)	N/A	N/A	N/A	10
010	1-in. (25 mm)	N/A	N/A	N/A	20
015	1.5-in. (40 mm)	N/A	N/A	N/A	50
020	2-in. (50 mm)	N/A	N/A	N/A	60
025	2.5-in. (65 mm)	N/A	N/A	N/A	50
030	3-in. (80 mm)	N/A	N/A	N/A	50
040	4-in. (100 mm)	N/A	50	N/A	70
050	5-in. (125 mm)	N/A	70	N/A	100
060	6-in. (150mm)	N/A	90	N/A	130
080	8-in. (200 mm)	130	90	130	170
100	10-in. (250 mm)	100	130	190	250
120	12-in. (300 mm)	120	170	190	270
140	14-in. (350 mm)	160	220	320	410
160	16-in. (400 mm)	220	280	410	610
180	18-in. (450 mm)	190	340	330	420
200	20-in. (500 mm)	230	380	440	520
240	24-in. (600 mm)	290	570	590	850
Size code	Line size	Resilient liners			
		PN 10 (Newton-meter)	PN 16 (Newton-meter)	PN 25 (Newton-meter)	PN 40 (Newton-meter)
010	1-in. (25 mm)	N/A	N/A	N/A	20
015	1.5-in. (40 mm)	N/A	N/A	N/A	30
020	2-in. (50 mm)	N/A	N/A	N/A	40
025	2.5-in. (65 mm)	N/A	N/A	N/A	35
030	3-in. (80 mm)	N/A	N/A	N/A	30
040	4-in. (100 mm)	N/A	40	N/A	50
050	5-in. (125 mm)	N/A	50	N/A	70
060	6-in. (150 mm)	N/A	60	N/A	90
080	8-in. (200 mm)	90	60	90	110
100	10-in. (250 mm)	70	80	130	170
120	12-in. (300 mm)	80	110	130	180
140	14-in. (350 mm)	110	150	210	280
160	16-in. (400 mm)	150	190	280	410
180	18-in. (450 mm)	130	230	220	280
200	20-in. (500 mm)	150	260	300	350
240	24-in. (600 mm)	200	380	390	560

**Table 6. Flange Bolt Torque and Load Specifications for Rosemount 8750W Larger Line Sizes (AWWA C207)**

Size code	Line size	Fluoropolymer liners		
		Class D (pound-feet)	Class E (pound-feet)	Class F (pound-feet)
300	30-in. (750 mm)	195	195	195
360	36-in. (900 mm)	280	280	280
		Resilient liners		
300	30-in. (750 mm)	165	165	165
360	36-in. (900 mm)	245	245	245
400	40-in. (1000 mm)	757	757	N/A
420	42-in. (1050 mm)	839	839	N/A
480	48-in. (1200 mm)	872	872	N/A

**Table 7. Flange Bolt Torque and Load Specifications for Rosemount 8750W Larger Line Sizes (EN 1092-1)**

Size code	Line size	Fluoropolymer liners		
		PN6 (Newton-meter)	PN10 (Newton-meter)	PN16 (Newton-meter)
360	36-in. (900 mm)	N/A	264	264
		Resilient liners		
360	36-in. (900 mm)	N/A	264	264
400	40-in. (1000 mm)	208	413	478
480	48-in. (1200 mm)	375	622	N/A

## 5.0 Process reference connection

Figure 12 through Figure 15 illustrate process reference connections only. Earth safety ground is also required as part of the installation but is not shown in the figures. Follow national, local, and plant electrical codes for safety ground.

Use Table 8 to determine which process reference option to follow for proper installation.

**Table 8. Process reference installation**

Process reference options			
Type of pipe	Grounding straps	Grounding rings	Reference electrode
Conductive unlined pipe	See Figure 12	See Figure 13 <sup>(1)</sup>	See Figure 15 <sup>(1)</sup>
Conductive lined pipe	Insufficient grounding	See Figure 13	See Figure 12
Non-conductive pipe	Insufficient grounding	See Figure 14	Not recommended

1. Grounding ring and reference electrode are not required for process reference. Grounding straps per Figure 12 are sufficient.

### Note

For line sizes 10-in. and larger, the ground strap may come attached to the sensor body near the flange. See Figure 16.

**Figure 12. Grounding Straps in Conductive Unlined Pipe or Reference Electrode in Lined Pipe**

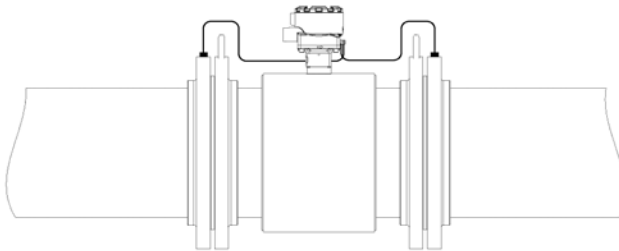



---

**Figure 13. Grounding with Grounding Rings in Conductive Pipe**

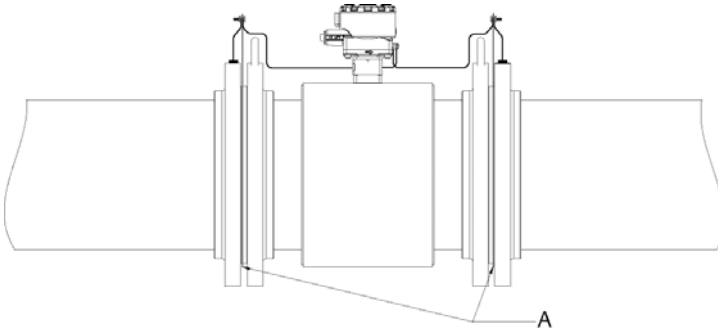

A. Grounding rings

---

---

**Figure 14. Grounding with Grounding Rings in Non-conductive Pipe**

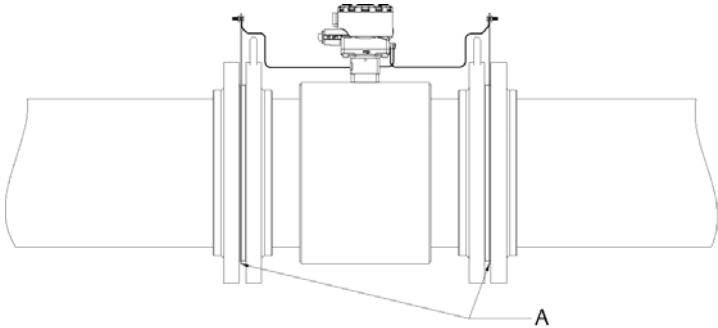

A. Grounding rings

---

---

**Figure 15. Grounding with Reference Electrode in Conductive Unlined Pipe**

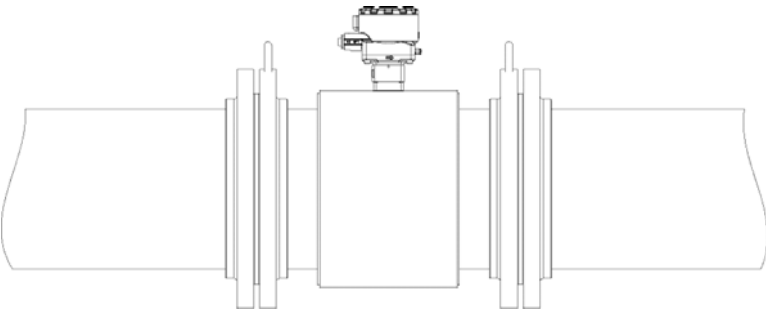

---

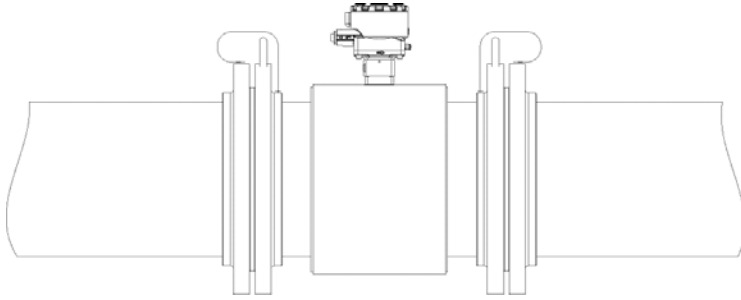
**Figure 16. Grounding for Line Sizes 10-in. and Larger**

---

## 6.0 Wiring the transmitter

This wiring section covers the wiring between the transmitter and sensor, the 4–20mA output, and supplying power to the transmitter. Follow the conduit information, cable requirements, and disconnect requirements in the sections below.

For sensor wiring diagrams, see Electrical Drawing 8750W-1504.

See Installation Drawing 8750W-1052.

### 6.1 Conduit entries and connections

The standard conduit entries for the transmitter and sensor are  $\frac{1}{2}$ -in. NPT. Conduit connections should be made in accordance with national, local, and plant electrical codes. Unused conduit entries should be sealed with the appropriate certified plugs. The flow sensor is rated IP68. For sensor installations requiring IP68 protection, the cable glands, conduit, and conduit plugs must be rated for IP68. The plastic shipping plugs do not provide ingress protection.

### 6.2 Conduit requirements

- Bundled cables from other equipment in a single conduit are likely to create interference and noise in the system. See [Figure 17](#).
- Electrode cables should not be run together and should not be in the same cable tray with power cables.
- Output cables should not be run together with power cables.
- Select conduit size appropriate to feed cables through to the flowmeter.

**Figure 17. Best Practice Conduit Preparation**

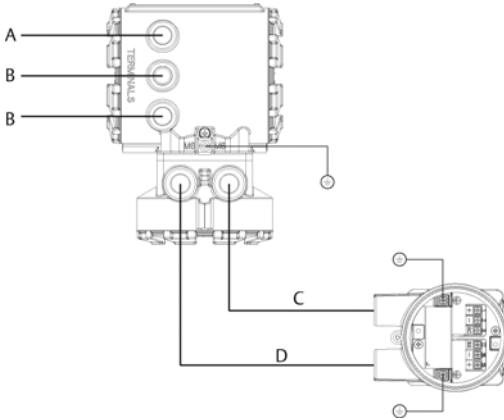

- A. Power
- B. Output
- C. Coil
- D. Electrode

### 6.3 Connecting sensor to transmitter

#### Integral mount transmitters

Integral mount transmitters ordered with a sensor will be shipped assembled and wired at the factory using an interconnecting cable (see [Figure 18](#)). Use only the interconnecting cable provided by Emerson Process Management.

For replacement transmitters use the existing interconnecting cable from the original assembly. Replacement cables are available.

**Figure 18. Interconnecting Cables**

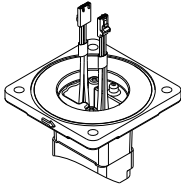

#### Remote mount transmitters

Cables kits are available as individual component cables or as a combination coil/electrode cable. Remote cables can be ordered direct from Rosemount using the kit numbers shown in [Table 9](#) and [Table 11](#). Equivalent Alpha cable part numbers are also provided as an alternative. To order cable, specify length as quantity desired. Equal length of component cables is required.

Example: 25-feet = Qty (25) 08732-0065-0001

**Table 9. Component Cable Kits**

Standard temperature (-20 °C to 75 °C)			
Cable kit number	Description	Individual cable	Alpha p/n
08732-0065-0001 (feet)	Kit, component cables, std temp. (includes coil + electrode)	Coil Electrode	518243 518245
08732-0065-0002 (meters)	Kit, component cables, std temp. (includes coil + electrode)	Coil Electrode	518243 518245
08732-0065-0003 (feet)	Kit, component cables, std temp. (includes coil + i.s. electrode)	Coil Intrinsically Safe Blue Electrode	518243 518245
08732-0065-0004 (meters)	Kit, component cables, std temp. (includes coil + i.s. electrode)	Coil Intrinsically Safe Blue Electrode	518243 518245

Extended temperature (-50 °C to 125 °C)			
Cable kit number	Description	Individual cable	Alpha p/n
08732-0065-1001 (feet)	Kit, component cables, ext temp. (includes coil + electrode)	Coil Electrode	840310 518189
08732-0065-1002 (meters)	Kit, component cables, ext temp. (includes coil + electrode)	Coil Electrode	840310 518189
08732-0065-1003 (feet)	Kit, component cables, ext temp. (includes coil + i.s. electrode)	Coil Intrinsically safe blue Electrode	840310 518189
08732-0065-1004 (meters)	Kit, component cables, ext temp. (includes coil + i.s. electrode)	Coil Intrinsically safe blue Electrode	840310 518189

**Table 10. Combination Cable Kits**

Coil and electrode cable (-20 °C to 80 °C)	
Cable kit number	Description
08732-0065-2001 (feet)	Kit, combination cable, standard
08732-0065-2002 (meters)	
08732-0065-3001 (feet)	Kit, combination cable submersible (80 °C dry/60 °C Wet) (33-ft. Continuous)
08732-0065-3002 (meters)	

### Cable requirements

Shielded twisted pairs or triads must be used. For installations using the individual coil drive and electrode cable, see [Figure 19](#). Cable lengths should be limited to less than 500-feet (152 m). Consult your local Emerson representative for length between 500–1000-feet (152-304 m). Equal length cable is required for each.

For installations using the combination coil drive/electrode cable, see [Figure 20](#). Combination cable lengths should be limited to less than 330-feet (100 m).

**Figure 19. Individual Component Cables**

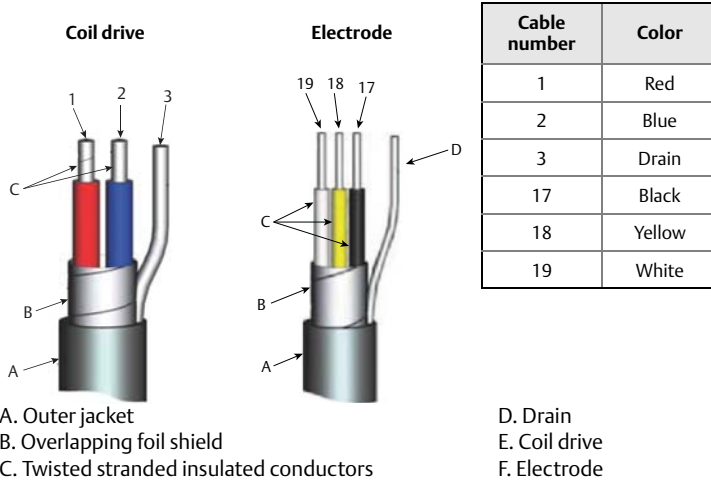

**Figure 20. Combination Coil and Electrode Cable**

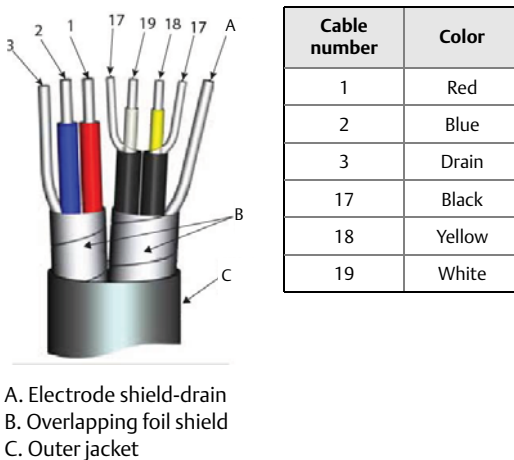

## Cable preparation

When preparing all wire connections, remove only the insulation required to fit the wire completely under the terminal connection. Prepare the ends of the coil drive and electrode cables as shown in [Figure 21](#). Limit the unshielded wire length to less than one inch on both the coil drive and electrode cables. Any length of unsheathed conductor should be insulated. Excessive removal of insulation may result in an unwanted electrical short to the transmitter housing or other wire connections. Excessive unshielded lead length, or failure to connect cable shields properly, may expose the unit to electrical noise, resulting in an unstable meter reading.

**Figure 21. Cable Ends**

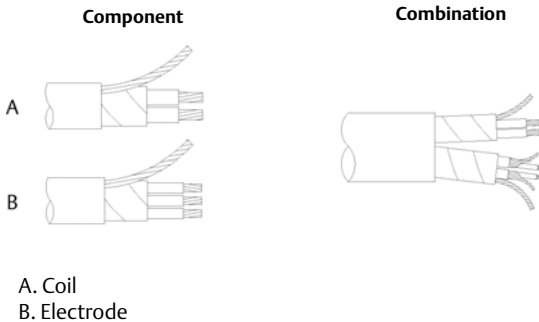

## ⚠ WARNING

### Shock Hazard

Potential shock hazard across remote junction box terminals 1 and 2 (40V).

### Explosion Hazard

Electrodes exposed to process. Use only compatible transmitter and approved installation practices.

**Figure 22. Remote Junction Box Views**

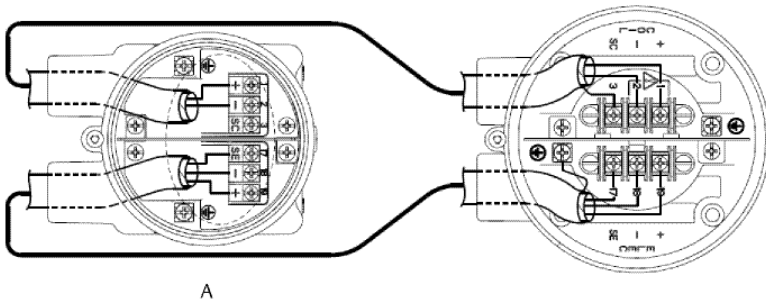

A. Sensor

For complete sensor wiring diagrams, reference Installation Drawing Rosemount 8750W-1052.

## 6.4 Transmitter terminal block connections

### Field mount transmitter

Remove the back cover of the transmitter to access the terminal block.

See [Figure 23](#) for terminal identification. To connect pulse output and/or discrete input/output consult the comprehensive product manual.

**Figure 23. Field Mount Terminal Block Connections**

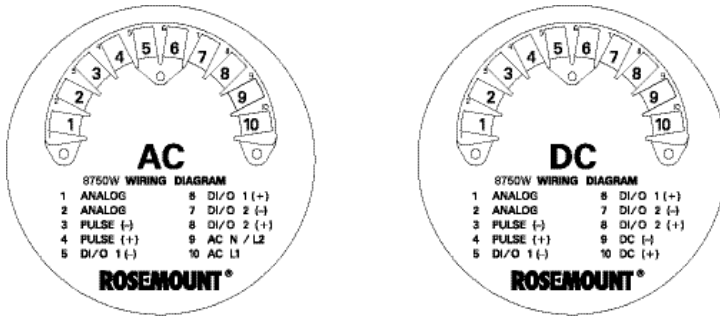

### Wall mount transmitter

Open the lower cover of the transmitter to access the terminal block.

See [Figure 24](#) for terminal identification or inside the over for wiring terminal identification. To connect the pulse output and or discrete input/output, consult the comprehensive product manual.

**Figure 24. Wall Mount Transmitter Terminal Block Connections**

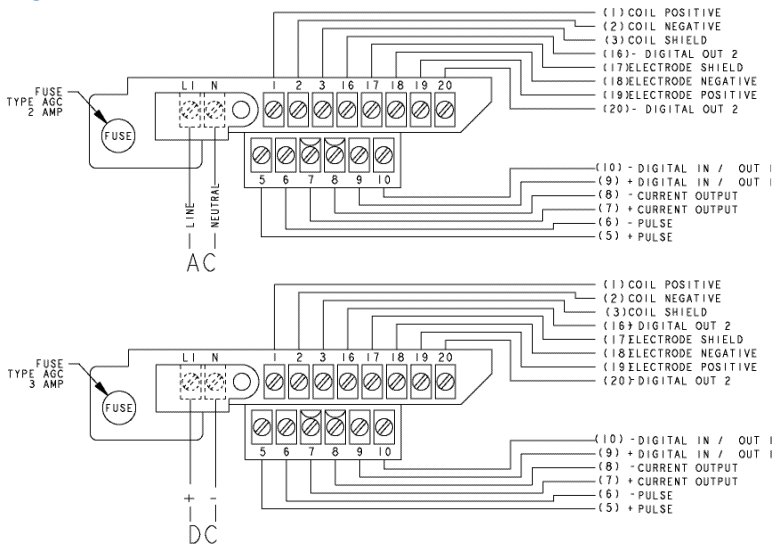

## 6.5 Analog output

### Field mount transmitter

The analog output signal is a 4–20mA current loop. The loop can be powered internally or externally via a hardware switch located on the front of the electronics stack. The switch is set to internal power when shipped from the factory. For field mount units with a display, the LOI must be removed to change switch position.

For HART communication a minimum resistance of 250 ohms is required. It is recommended to use individually shielded twisted pair cable. The minimum conductor size is 0.51 mm diameter (#24 AWG) for cable runs less than 5,000-feet (1,500m) and 0.81 mm diameter (#20 AWG) for longer distances.

### Internal power

The 4-20mA analog signal is a 24VDC active output.

Maximum allowable loop resistance is 500 ohms.

Wire terminal 1 (+) and terminal 2 (-). See [Figure 25](#).

**Figure 25. Field Mount Transmitter Analog Wiring - Internal Power**

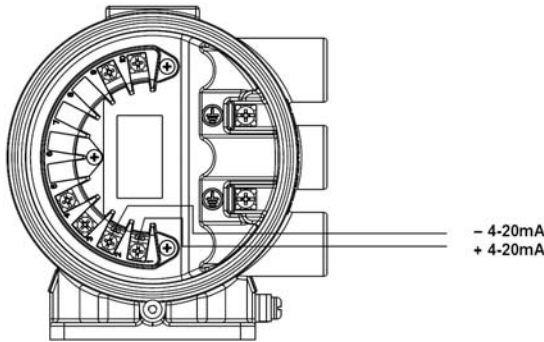

### NOTICE

Terminal polarity for the analog output is reversed between internally and externally powered.

### External power

The 4–20mA analog signal is passive and must be powered from an external power source. Power at the transmitter terminals must be 10.8–30VDC.

Wire terminal 1 (-) and terminal 2 (+). See [Figure 26](#).



**Figure 26. Field Mount Transmitter Analog Wiring - External Power**

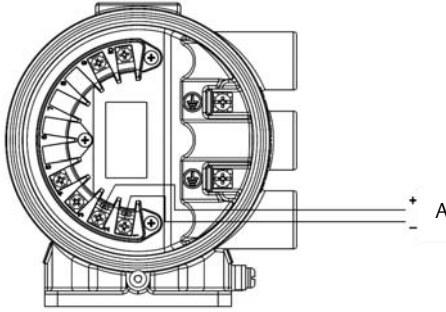

A. Power supply

### Analog loop load limitations

Maximum loop resistance is determined by the voltage level of the external power supply, as described in Figure 27.

**Figure 27. Field Mount Transmitter Analog Loop Load Limitations**

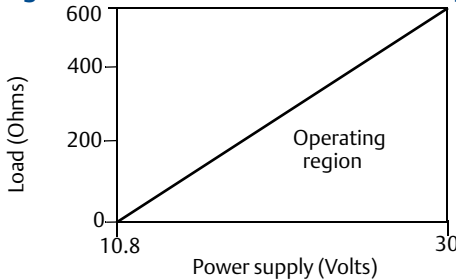

$$R_{\text{max}} = 31.25 (V_{\text{ps}} - 10.8)$$

$V_{\text{ps}}$  = Power supply voltage (Volts)  
 $R_{\text{max}}$  = Maximum loop resistance (Ohms)

### Wall mount transmitter

The analog output signal is a 4–20mA current loop. The loop can be powered internally or externally via a hardware switch. The switch is set to internal power when shipped from the factory.

For HART communication a minimum resistance of 250 ohms is required. It is recommended to use individually shielded twisted pair cable. The minimum conductor size is 0.51mm diameter (#24 AWG) for cable runs less than 5,000-foot (1,500m) and 0.81mm diameter (#20 AWG) for longer distances.

### Internal power

The 4–20mA analog signal is a 24VDC active output.

Maximum allowable loop resistance is 500 ohms.

### External power

The 4–20 mA analog signal is powered from an external power source. HART multidrop installations require a 10–30VDC external analog power source.

**Figure 28. Wall Mount Transmitter Analog Wiring**

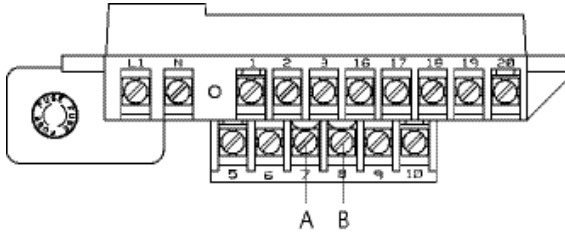

- A. +4–20 mA
- B. -4–20 mA

### Analog loop load limitations

Maximum loop resistance is determined by the voltage level of the external power supply, as described in Figure 29.

**Figure 29. Wall Mount Transmitter Analog Loop Load Limitations**

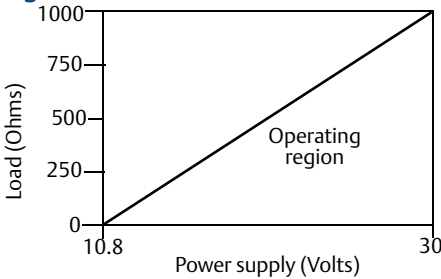

$$R_{\max} = 52.08 (V_{ps} - 10.8)$$

$V_{ps}$  = Power supply voltage (Volts)  
 $R_{\max}$  = Maximum loop resistance (Ohms)

## 6.6 Powering the transmitter

The transmitter is available in two models. The AC powered transmitter is designed to be powered by 90–250VAC (50/60Hz). The DC powered transmitter is designed to be powered by 12–42VDC. Before connecting power to the Rosemount 8750W, be sure to have the proper power supply, conduit, and other accessories. Wire the transmitter according to national, local, and plant electrical requirements for the supply voltage.

See Figure 30 or Figure 32.

**Figure 30. Field Mount Transmitter DC Power Requirements**

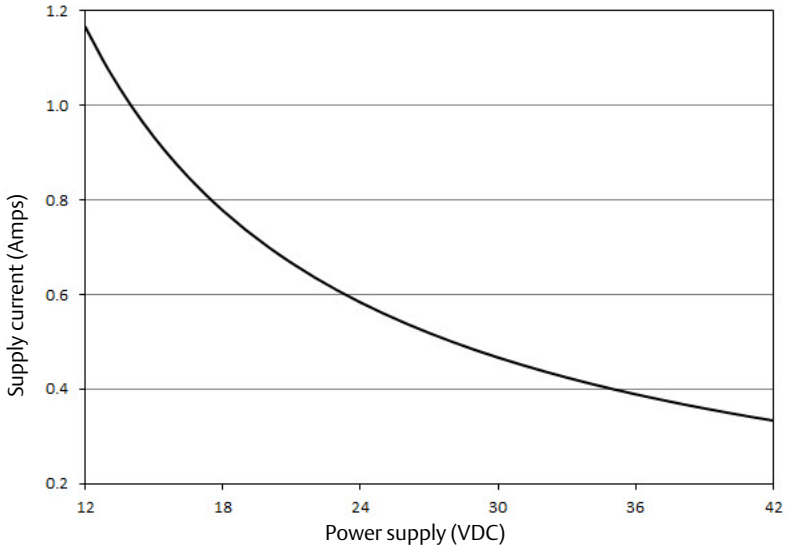

Peak inrush is 42A at 42VDC supply, lasting approximately 1 ms.

Inrush for other supply voltages can be estimated with:

$$\text{Inrush (Amps)} = \text{Supply (Volts)} / 1.0$$

**Figure 31. Wall Mount Transmitter DC Power Requirements**

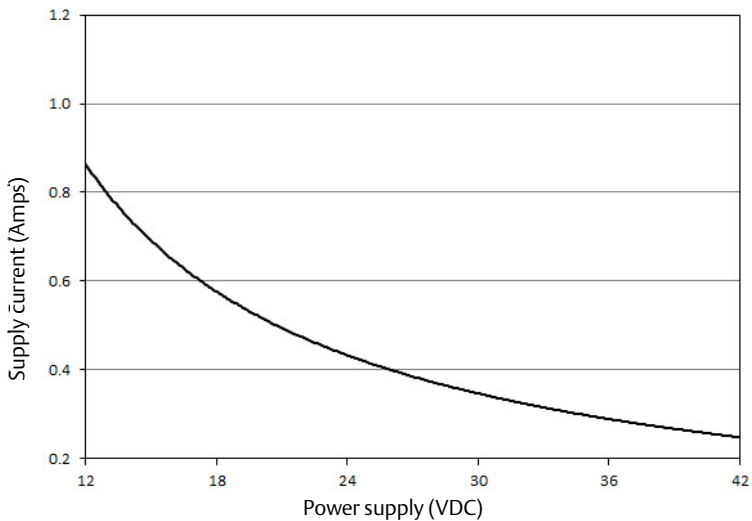

**Figure 32. Field Mount Transmitter AC Power Requirements**

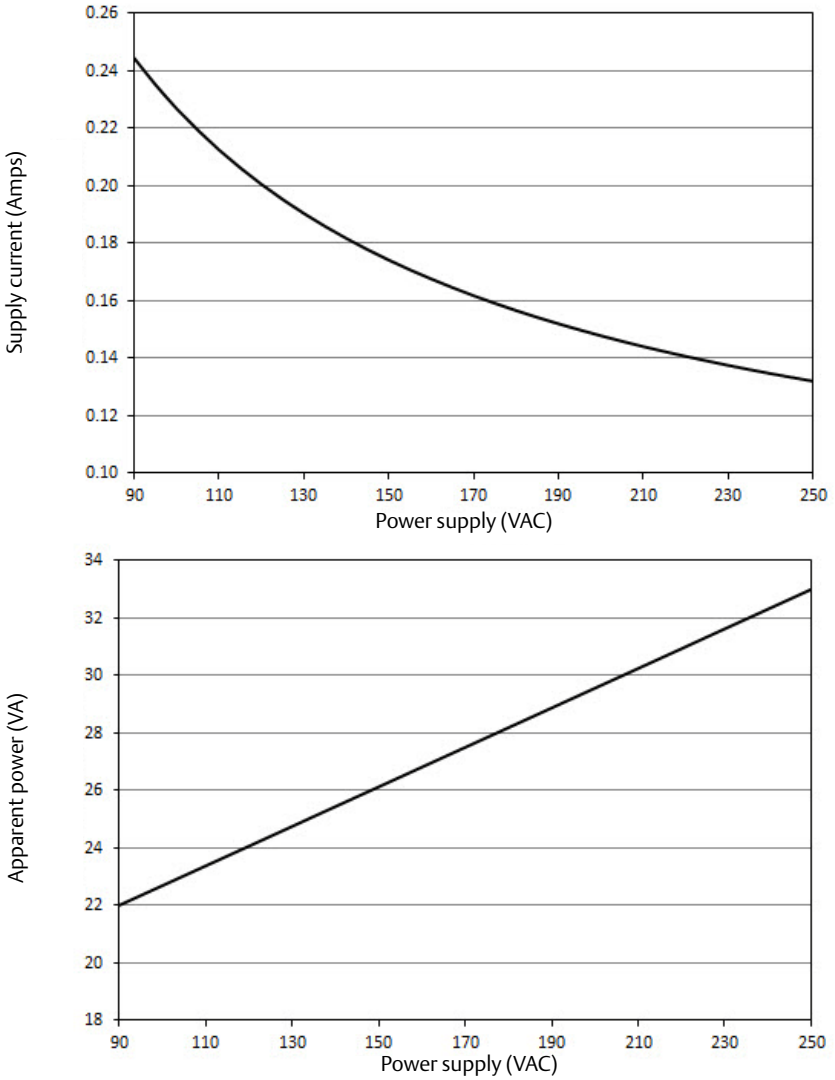

Peak inrush is 35.7A at 250VAC supply, lasting approximately 1ms.

Inrush for other supply voltages can be estimated with:

$$\text{Inrush (Amps)} = \text{Supply (Volts)} / 7.0$$

**Figure 33. Wall Mount Transmitter AC Power Requirements**

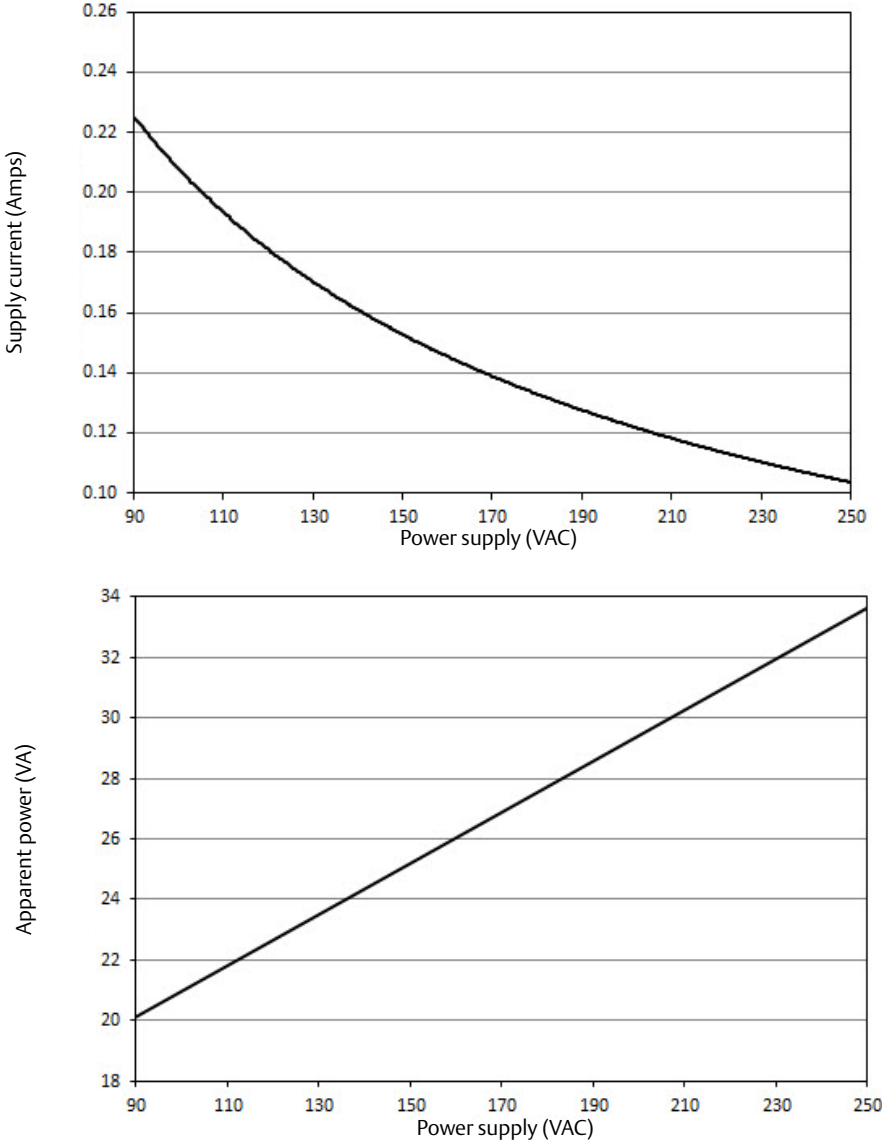

## Supply wire requirements

Use 10–18 AWG wire rated for the proper temperature of the application. For wire 10–14 AWG use lugs or other appropriate connectors. For connections in ambient temperatures above 122 °F (50 °C), use a wire rated for 194 °F (90 °C). For DC powered transmitters with extended cable lengths, verify that there is a minimum of 12VDC at the terminals of the transmitter with the device under load.

## Disconnects

Connect the device through an external disconnect or circuit breaker per national and local electrical code.

## Installation category

The installation category for the Rosemount 8750W is OVERVOLTAGE CAT II.

## Overcurrent protection

The Rosemount 8750W Transmitter requires overcurrent protection of the supply lines. Fuse rating and compatible fuses are shown in [Table 11](#) and [Table 12](#).

**Table 11. Field Mount Transmitter Fuse Requirements**

Input voltage	Fuse rating	Compatible fuse
90-250VAC rms	1 Amp, 250V, $I^2t \geq 1.5 A^2s$ Rating, Fast Acting	Bussman AGC-1, Littelfuse 31201.5HXP
12-42VDC	3 Amp, 250V, $I^2t \geq 14 A^2s$ Rating, Fast Acting	Bel Fuse 3AG 3-R, Littelfuse 312003P, Schurter 0034.5135

**Table 12. Wall Mount Transmitter Fuse Requirements**

Input voltage	Fuse rating	Compatible fuse
90–250VAC	2 Amp, fast acting	Bussman AGC-2
12–42VDC	3 Amp, fast acting	Bussman AGC-3

## Field mount transmitter power terminals

See [Figure 23](#) for field mount terminal connections.

For AC powered transmitter (90–250VAC, 50/60 Hz)

- Connect AC Neutral to terminal 9 (AC N/L2) and AC Line to terminal 10 (AC/L1).

For DC powered transmitter

- Connect negative to terminal 9 (DC -) and positive to terminal 10 (DC +).
- DC powered units may draw up to 1.2A.

## Wall mount transmitter power terminals

See [Figure 24](#) for wall mount transmitter terminal connections.

For AC powered transmitter (90–250VAC, 50/60 Hz)

- Connect AC Neutral to terminal N and AC Line to terminal L1.

For DC powered transmitter

- Connect DC- to terminal N and DC+ to terminal L1.

## Field mount transmitter cover jam screw

For flow meters shipped with a cover jam screw, the screw should be installed after the instrument has been wired and powered up. Follow the steps to install the cover jam screw:

1. Verify the cover jam screw is completely threaded into the housing.
2. Install the housing cover and verify the cover is tight against the housing.
3. Using a 2.5 mm hex wrench, loosen the jam screw until it contacts the transmitter cover.
4. Turn the jam screw an additional  $1/2$  turn counterclockwise to secure the cover.

---

### Note

Application of excessive torque may strip the threads.

---

5. Verify the cover cannot be removed.

## 7.0 Basic configuration

Once the magnetic flowmeter is installed and power has been supplied, the transmitter must be configured through the basic setup. These parameters can be configured through either a local operator interface or a HART communication device. Configuration settings are saved in nonvolatile memory within the transmitter. A table of all the parameters is located in [Table 13](#). Descriptions of the more advanced functions are included in the comprehensive product manual.

### 7.1 Basic setup

#### Tag

Tag is the quickest and shortest way of identifying and distinguishing between transmitters. Transmitters can be tagged according to the requirements of your application. The tag may be up to eight characters long.

#### Flow units (PV)

The flow units variable specifies the format in which the flow rate will be displayed. Units should be selected to meet your particular metering needs.

#### Line size

The line size (sensor size) must be set to match the actual sensor connected to the transmitter. The size must be specified in inches.

**URV (upper range value)**

The URV sets the 20 mA point for the analog output. This value is typically set to full-scale flow. The units that appear will be the same as those selected under the flow units parameter. The URV may be set between  $-39.3$  ft/s to  $39.3$  ft/s ( $-12$  m/s to  $12$  m/s). There must be at least  $1$  ft/s ( $0.3$  m/s) span between the URV and LRV.

**LRV (lower range value)**

The LRV sets the 4 mA point for the analog output. This value is typically set to zero flow. The units that appear will be the same as those selected under the flow units parameter. The LRV may be set between  $-39.3$  ft/s to  $39.3$  ft/s ( $-12$  m/s to  $12$  m/s). There must be at least  $1$  ft/s ( $0.3$  m/s) span between the URV and LRV.



## 7.2 Calibration number

The sensor calibration number is a 16-digit number generated at the Rosemount factory during flow calibration and is unique to each sensor and is located in the sensor tag.

**Table 13. Handheld Fast Keys (Field Communicator)**

Function	HART fast keys
Process variables	1, 1
Primary Variable (PV)	1, 1, 1
PV Percent of range (PV % rnge)	1, 1, 2
PV Analog Output (AO) (PV Loop current)	1, 1, 3
Totalizer set-up	1, 1, 4
Totalizer units	1, 1, 4, 1
Gross total	1, 1, 4, 2
Net total	1, 1, 4, 3
Reverse total	1, 1, 4, 4
Start totalizer	1, 1, 4, 5
Stop totalizer	1, 1, 4, 6
Reset totalizer	1, 1, 4, 7
Pulse output	1, 1, 5
Basic setup	1, 3
Tag	1, 3, 1
Flow units	1, 3, 2
PV units	1, 3, 2, 1
Special units	1, 3, 2, 2
Line size	1, 3, 3
PV Upper Range Value (URV)	1, 3, 4
PV Lower Range Value (LRV)	1, 3, 5
Calibration number	1, 3, 6
PV Damping	1, 3, 7
Review	1, 5

## 7.3 Field mount transmitter local operator interface

To activate the optional Local Operator Interface (LOI), press the DOWN arrow two times. Use the UP, DOWN, LEFT, and RIGHT arrows to navigate the menu structure. A map of the LOI menu structure is shown on [Figure 34](#). The display can be locked to prevent unintentional configuration changes. The display lock can be activated through a HART communication device, or by holding the UP arrow for three seconds and then following the on-screen instructions. When the display lock is activated, a lock symbol will appear in the lower right hand corner of the display. To deactivate the display lock, hold the UP arrow for three seconds and follow the on-screen instructions. Once deactivated, the lock symbol will no longer appear in the lower right hand corner of the display.

Figure 34. Field Mount Transmitter Local Operator Interface (LOI) Menu Tree

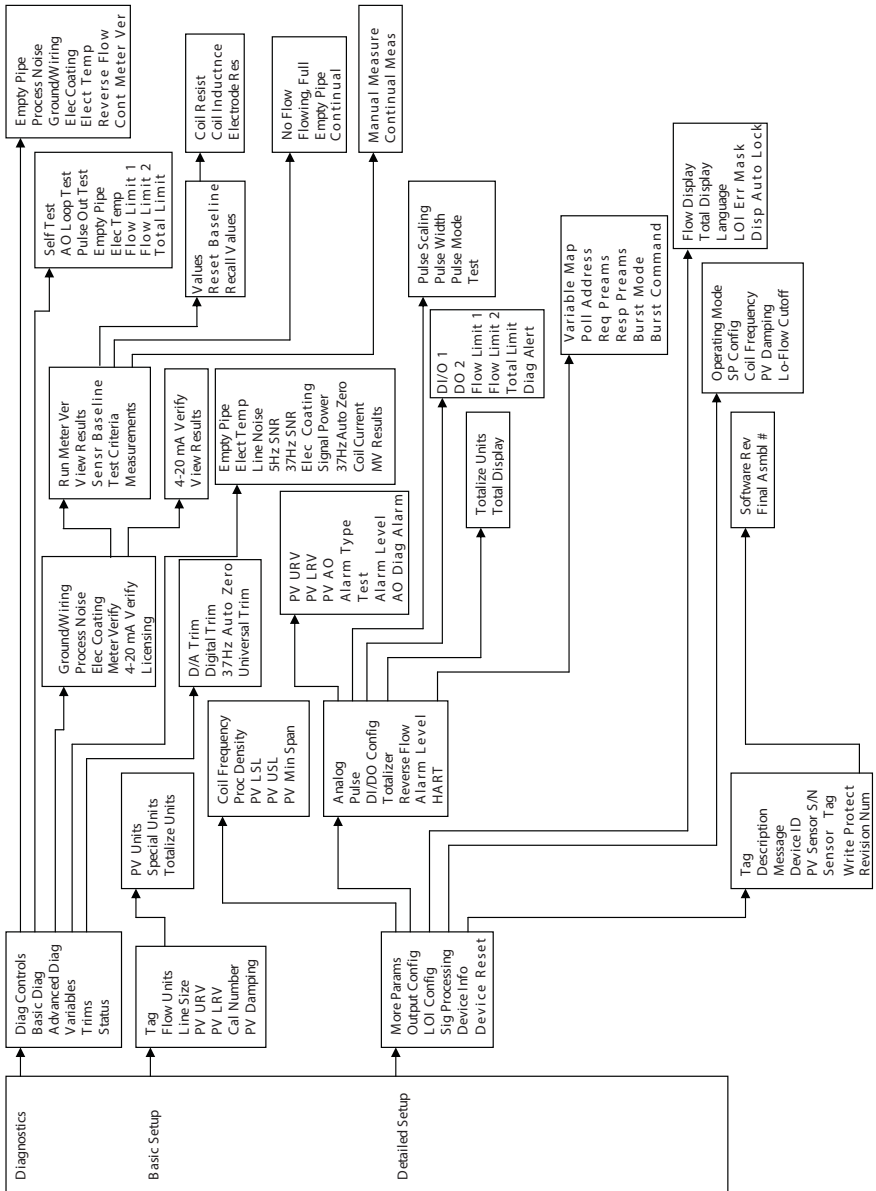

Figure 35. Wall Mount Transmitter Local Operator Interface (LOI) Menu Tree











## 8.0 Product Certifications

**Table 14. Rosemount 8750W Platform**

Order code	Platform rating	Region	Agency	Certification number
-	Ordinary Locations <sup>(1)</sup>	USA, Canada EU, CU <sup>(2)</sup>	FM or CSA and EAC	3030548(FM) or 70030489(CSA)
Z1	ATEX Non-Sparking and Dust for Non-Flammable Fluids	EU	DEKRA	15ATEX0003 X
ND	ATEX Dust	EU	DEKRA	15ATEX0003 X
Z2	InMetro Non-Sparking and Dust for Non-Flammable Fluids	Brazil	PENDING <sup>(3)</sup>	PENDING
Z3	NEPSI Non-Sparking and Dust for Non-Flammable Fluids	China	NEPSI	GYJ15.1228X
Z5	DIP (Dust-Ignitionproof) Class II and III, Div 1, Non-Incendive, Class I Div 2 for Non-Flammable Fluids	USA	FM	3030548
Z6	CSA, Class I Div 2 for Non-Flammable Fluids; DIP, NI	USA and Canada	CSA	70030489
Z7	IECEx Non-Sparking and Dust for Non-Flammable Fluids	Global	DEKRA	IECEx DEK 15.0001X
NF	IECEx Dust	Global	DEKRA	IECEx DEK 15.0001X
Z9	KTL Non-Sparking and Dust for Non-Flammable Fluids	Korea	KTL <sup>(3)</sup>	PENDING

1. Complies with only the local country Product safety, electromagnetic, pressure and other applicable regulations. Cannot be used in a classified or zoned hazardous location environment.
2. Customs union (Russia, Belarus and Kazakhstan).
3. Planned submittal or in process with agency.

**Table 15. Approval Markings and Logos**

Symbol <sup>(1)</sup>	Marking or symbol name	Region	Meaning of marking or symbol
	CE	European Union	Compliance with all applicable European Union Directives.
	ATEX	European Union	Compliance with Equipment and Protective systems intended for use in Potentially Explosive Atmospheres directive (ATEX) (94/9/EC).
	C-tick	Australia	Compliance with Australian applicable electromagnetic compatibility standards.
	FM Approved	United States	Compliance with the applicable ANSI standards.
	CSA	US = United States C = Canada	Indicates that the product was tested and has met the applicable certification requirements for the noted countries.
	Eurasian Conformity (EAC)	Eurasian Customs Union (Russia, Belarus and Kazakhstan)	Compliance with all of the applicable technical regulations of the EAC Customs Union.
	INMETRO	Brazil	Compliance with all of the applicable technical regulations of Brazil.
	NEPSI	China	Compliance with all of the applicable technical regulations of China.
	KTL	Korea	Compliance with all of the applicable technical regulations of Korea.

1. Ordinary Location labels will be marked with CE, C-tick, FM, CSA, and EAC logos.

## 8.1 European Directive Information

A copy of the EC Declaration of Conformity can be found at the end of the Quick Start Guide. The most recent revision of the EC Declaration of Conformity can be found at [EmersonProcess.com/Rosemount](http://EmersonProcess.com/Rosemount).

### **Electro Magnetic Compatibility (EMC) (2004/108/EC) and (2014/30/EU)**

EN 61326-1: 2013

### **Low Voltage Directive (LVD) (2006/95/EC) and (2014/35/EU)**

EN 61010-1: 2010

### **Ingress protection rating for dust and water**

Degree of protection, per EN-IEC 60079-0 and EN-IEC 60529: IP66<sup>(1)</sup>

Degree of protection, per EN-IEC 60079-0 and EN-IEC 60529: IP66, IP68 (10m, 48h)<sup>(2)</sup>

Degree of protection, per EN-IEC 60079-0 and ISO 20653: IP69K<sup>(3)</sup>

### **European Pressure Equipment Directive (PED) (97/23/EC) and (2014/68/EU)**

PED Certification requires the “PD” option code.

CE marked models that are ordered without the “PD” option will be marked “Not Compliant to (97/23/EC and 2014/68/EU)”

Mandatory CE-marking with notified body number 0575 or 2460, for all flowtubes is located on the flowmeter label.

Category I assessed for conformity per module A procedures.

Categories II - III assessed for conformity per module H procedures.

QS Certificate of Assessment

EC No. 4741-2014-CE-HOU-DNV: Module H Conformity Assessment

### **Rosemount 8750W Flanged Flowtubes**

Line size 40 mm to 600 mm (1½-in to 24-in)

EN 1092-1 flanges and ASME B16.5 class 150 and ASME B16.5 Class 300 flanges.

Also available in ASME B16.5 Class 600 flanges in limited line sizes.

All other Rosemount Flanged Flowtubes - line sizes of 25 mm (1-in.) and less: Sound Engineering Practice (SEP).

Flowtubes that are SEP are outside the scope of PED and cannot be marked for compliance with PED.

1. *The transmitter is rated IP66 when integral or remote mounted, it is not IP68 nor IP69K rated.*
2. *The IP68 rating only applies to the flowtube and the remote junction box when the transmitter is remotely mounted. The IP68 rating is only valid at a depth of 10 meters for 48 hours.*
3. *The IP69K rating only applies to the flowtube and the remote junction box when the transmitter is remotely mounted. The temperature K = 80 °C.*

## 8.2 Certifications

### Factory Mutual (FM)

#### Ordinary Location Certification for FM Approvals

As standard, the transmitter and flowtube have been examined and tested to determine that the design meets basic electrical, mechanical, and fire protection requirements by FM Approvals, a nationally recognized testing laboratory (NRTL) as accredited by the Federal Occupational Safety and Health Administration (OSHA).

#### Rosemount 8750W Magnetic Flowtube and Transmitter

- Z5** All Flowtubes and Integral or Remote Mount Transmitters (Transmitter mount codes T or R)  
 Non-Incendive for Class I, Division 2, Groups ABCD: T4 Dust-Ignition Proof for Class II/III, Division 1, Groups EFG:  $T_5 -29\text{ }^{\circ}\text{C} \leq T_a \leq 60\text{ }^{\circ}\text{C}$   
 Enclosure Type 4X, IP66/68 (IP68 flowtube only with Remote mount transmitter)  
 Install per drawing 8750W-1052.

**Special Condition for Safe Use (X):**

1. Flowtube to be used only in a non-flammable process.

#### Rosemount 8750W Magnetic Flowtube and Transmitter

- Z5** All Flowtubes and Wall Mount Transmitter (Transmitter mount code W)  
 Non-Incendive for Class I, Division 2, Groups ABCD: T4 Dust-Ignition Proof for Class II/III, Division 1, Groups EFG:  $T_4 -29\text{ }^{\circ}\text{C} \leq T_a \leq 40\text{ }^{\circ}\text{C}$   
 Enclosure Type 4X, IP66/68 (IP68 flowtube only)  
 Install per drawing 8750W-1052.

**Special Condition for Safe Use (X):**

1. Flowtube to be used only in a non-flammable process.

### CSA

#### Ordinary Location Certification for FM Approvals

As standard, the transmitter and flowtube have been examined and tested to determine that the design meets basic electrical, mechanical, and fire protection requirements by FM Approvals, a nationally recognized testing laboratory (NRTL) as accredited by the Federal Occupational Safety and Health Administration (OSHA).

#### Rosemount 8750W Magnetic Flowtube and Transmitter

- Z6** Non-Incendive for Class I, Division 2, Groups ABCD: T4  
 Dust-Ignition Proof for Class II/III, Division 1, Groups EFG:  $T_4 -29\text{ }^{\circ}\text{C} \leq T_a \leq 60\text{ }^{\circ}\text{C}$   
 (Transmitter mount codes T or R)  
 $-29\text{ }^{\circ}\text{C} \leq T_a \leq 40\text{ }^{\circ}\text{C}$  (Transmitter mount code W)  
 Enclosure Type 4X, IP66/68/69K<sup>(1)</sup>  
 Install per drawing 8750W-1052.



**Special Condition for Safe Use (X):**

1. Flowtube to be used only in a non-flammable process.

1. *The transmitter is rated IP66 when integral or remote mounted, it is not IP68 nor IP69K rated. The IP68 rating only applies to the flowtube and the remote junction box when the transmitter is remotely mounted. The IP68 rating is only valid at a depth of 10 meters for 48 hours. The IP69K rating only applies to the flowtube and the remote junction box when the transmitter is remotely mounted. The temperature K = 80 °C.*



Figure 36. Rosemount 8750W Declaration of Conformity

		
<h2 style="margin: 0;">EC Declaration of Conformity</h2> <p style="margin: 0;"><b>No: RFD 1098 Rev. G</b></p>		
<p>We,</p> <p style="margin-left: 40px;"><b>Emerson Process Management Rosemount Flow 12001 Technology Drive Eden Prairie, MN 55344 USA</b></p>		
<p>declare under our sole responsibility that the product(s),</p> <p style="text-align: center;"><b>Rosemount Model 8750W Magnetic Flowmeters</b></p>		
<p>to which this declaration relates, is in conformity with the provisions of the European Community Directives, including the latest amendments, as shown in the attached schedule.</p>		
<p>Assumption of conformity is based on the application of harmonized or applicable technical standards and, when applicable or required, a European Community notified body certification, as shown in the attached schedule.</p>		
		
<p>(signature)</p>		
<p><b>22 February 2016</b></p> <hr style="width: 100%;"/> <p>(date of issue)</p>	<p><b>Mark Fleigle</b></p> <hr style="width: 100%;"/> <p>(name - printed)</p>	
	<p><b>Vice President Technology and New Products</b></p> <hr style="width: 100%;"/> <p>(function name - printed)</p>	
<p>F FILE ID: 8750W CE Marking</p>	<p>Page 1 of 3</p>	<p>RFD1098.docx</p>

**ROSEMOUNT**

### Schedule

#### EC Declaration of Conformity RFD 1098 Rev. G

**LVD Directive (2006/95/EC) and (2014/35/EU) as of 20 April 2016**

All Models: EN 61010-1: 2010

---

**EMC Directive (2004/108/EC) and (2014/30/EU) as of 20 April 2016**

All Models: EN 61326-1: 2013

---

**PED Directive (97/23/EC) and (2014/68/EU) as of 19 July 2016**

**Model 8750W Magnetic Flowtube with Option "PD", in Line Sizes 1.5" – 24"**

**Equipment without the 'PD' option is NOT PED compliant and cannot be used in the EEA without further assessment unless the installation is exempt under Article 1, paragraph 3 of the PED Directive (97/23/EC) or (2014/68/EU)**

QS Certificate of Assessment - EC No. 4741-2014-CE-HOU-DNV  
Module H Conformity Assessment  
ASME B31.3: 2010

**Model 8750W in Line Sizes 0.5" – 1.0"**  
Sound Engineering Practice  
ASME B31.3: 2010

---



**Schedule**

**EC Declaration of Conformity RFD 1098 Rev. G**

**ATEX Directive (94/9/EC) and (2014/34/EU) as of 20 April 2016**

**Model 8750W Magnetic Flow Transmitter and Flow Tubes**

**CERTIFICATE: DEKRA 15ATEX0003 X  
Equipment Marking Summary:**



II 3 G	Ex nA [ic] IIC T4 Gc
II 3 G	Ex nA ic IIC T5...T4 Gc
II 3 D	Ex tc III C T 80°C...T 130°C Dc

EN 60079-0: 2012 +A11:2013	EN 60079-11: 2012
EN 60079-15: 2010	EN 60079-31: 2014

**PED Notified Body**

**DNV GL** [Notified Body Number: 0575]  
Veritasveien 1, N-1322  
Hovik, Norway

**Or**

**DNV Nemko Presafe AS** [Notified Body number: 2460]  
P.O. Box 73, Blindern  
0314 Oslo, Norway

## 8.3 IEC EX & ATEX

---

1. Equipment markings:
  - a. Type Examination Certificate (ATEX): DEKRA 15ATEX0003 X
  - b. Certificate of Conformity (IECEX): IECEX DEK 15.0001X
2. Required documentation:
  - a. 8750W-2052 Installation Drawing Model 8750W ATEX/IECEX Hazardous (Ex) Locations
3. Referenced documentation:
  - a. 00825-0300-4750.pdf, Quick Installation Guide
  - b. 00809-0300-4750.pdf, Reference Manual
  - c. 8750W-AP01, Approvals Document
  - d. 8750W-1504 Installation Drawing, 8750W Transmitter Wiring
4. The Required and Referenced Documents listed above address the following items:
  - a. Instructions for safety i.e.
    - i. Putting into service
    - ii. Use
    - iii. Assembling and dismantling
    - iv. Maintenance, overhaul and repair
    - v. Installation
    - vi. Adjustment
  - b. Where necessary, training instructions
  - c. Details which allow a decision to be made as to whether the equipment can be used safely in the intended area under the expected operating conditions.

- d. Electrical parameters, maximum surface temperatures and other limit values.
  - i. Electrical
    - 1. See document 8750W-2052

<b>Rosemount 8750W Flow Transmitter</b>	
Power input	90 - 250 VAC, 0.45 A, 40 VA 12 - 42 VDC, 1.2 A, 15 W
Pulsed circuit	Internally powered (Active): outputs up to 12 VDC, 12.1 mA, 73 mW Externally powered (Passive): input up to 28 VDC, 100 mA, 1 W
4-20 mA output circuit	Internally Powered (Active): outputs up to 25 mA, 24 VDC, 600 mW Externally Powered (Passive): input up to 25 mA, 30 VDC, 750 mW
Modbus®	Internally Powered (Active): outputs up to 100 mA, 3.3 VDC, 100 mW
Um	250 V
Coil excitation output	500 mA, 40 V <sub>max</sub> , 9 W <sub>max</sub>
<b>Rosemount 8750W Flowtube<sup>(1)</sup></b>	
Coil excitation input	500 mA, 40 V <sub>max</sub> , 20 W <sub>max</sub>
Electrode circuit	5 V, 200 uA, 1 mW

- 1. Provided by the transmitter.

**Special Conditions for Safe Use (X):**

- 1. When “Special Paint Systems” are applied, instructions for safe use regarding potential electrostatic charging hazard have to be followed.
  - 2. Terminals 1,2,3,4, for data communication, cannot withstand the 500 V isolation test between signal and ground, due to integral transient protection. This must be taken into account upon installation.
  - 3. Conduit entries must be installed to maintain the enclosure ingress rating of IP66 (Transmitter and Flow Tube), IP68 or IP69K (Flow Tube) as applicable.
  - 4. The flow tube and transmitter are not allowed to be thermally insulated.
- e. Where necessary, the essential characteristics of tools which may be fitted to the equipment
    - i. No proprietary tools required.
  - f. List of the standards, including the issue date, with which the equipment is declared to comply:
    - i. ATEX - EN 60079-0 : 2012 + A11 : 2013, EN 60079-11 : 2012, EN 60079-15 : 2010, EN 60079-31 : 2014
    - ii. IECEx - IEC 60079-0: 2011, IEC 60079-11: 2011, IEC 60079-15: 2010, IEC 60079-31: 2013

- g. Supply wire requirements;  
Use 10–18 AWG wire rated for the proper temperature of the application.  
For wire 10–14 AWG use lugs or other appropriate connectors. For connections in ambient temperatures above 122 °F (50 °C), use a wire rated for 194 °F (90 °C).
- h. Contact address:  
Rosemount Inc.  
12001 Technology Drive  
Eden Prairie,  
MN 55344  
United States of America

**Table 16. Nomenclature Magnetic Flow Meter System Model Rosemount 8750W and Electrical Data**

8750W ... R 1 A 2 ... F 005 ... Z1 ... M4 ... AX ... V1 ... RH50  
 I II III IV V VI VII VIII IX X XI IX

Designation	Explanation	Value	Explanation
I	Model	8750W	Flow Meter System Model 8750W
II	Transmitter mount	R T	Remote mount Integral mount
III	Transmitter power supply	1 2	AC (90–250 Vac, 50/60 Hz), not for Ex nA DC (12–42 Vdc)
IV	Transmitter outputs	A M 0	4–20 mA with digital HART Protocol and scalable pulse output Modbus RS-485 Spare flow tube, no transmitter
V	Conduit entries	1 or 4 2 or 5	1/2–14 NPT female CM20, M20 female
VI	Electrode type	A, B, E, F 0	Seal of electrodes comply with IEC 61010-1. Spare transmitter, no flow tube
VII	Line size	005 to 480 000	1/2-in. NPS (15 mm) to 48-in NPS (1200 mm) Spare transmitter, no flow tube
VIII	Safety approvals	Z1 ATEX	⊗ II 3 GEx nA [ic] IIC T4 Gc <sup>(1)</sup> ⊗ II 3 GEx nA ic IIC T5...T4 Gc <sup>(2)</sup> ⊗ II 3 DEx tc IIIC T80 °C...T130 °C Dc <sup>(3)</sup>
		Z7 IECEx	Ex nA [ic] IIC T4 Gc <sup>(1)</sup> Ex nA ic IIC T5...T4 Gc <sup>(2)</sup> Ex tc IIIC T80 °C...T130 °C Dc <sup>(3)</sup>
		ND ATEX	⊗ II 3 D Ex tc IIIC T80 °C...T130 °C Dc <sup>(3)</sup>
		NF IECEx	Ex tc IIIC T80 °C...T130 °C Dc <sup>(3)</sup>
IX	Transmitter display	M4 M5	LOI Display
X	Transmitter discrete input/output	AX	Two discrete channels (DI/DO 1, DO 2)
XI	Specials paint	Vx	Special paint systems <sup>(4)</sup>
XII	Remote cable option	RTxx <sup>(5)</sup> RHxx <sup>(5)</sup>	Standard temperature component Extended temperature component

1. Model 8750W Transmitter DC Power Supply only.
2. Model 8750W Flow Tube only.
3. Model 8750W Transmitter AC and DC Power Supply and Model 8750W Flow Tube.
4. Subject to special conditions for safe use.
5. Length = xx min. 10-ft, max. 500-ft.

# 9.0 Installation and wiring drawings

THIS SHEET FOR 8750W REMOTE TRANSMITTER WITH COMPONENT CABLES

SEE WIRING NOTE FOR WIRING CONNECTION AT FLOWTUBE

SEE TEXT DETAIL

**MODEL 8750W TRANSMITTER**

**MODEL 8750W FLANGED FLOW TUBES**

**MODEL 8750W WAFER FLOWTUBES**

UNSHIELDED CABLES TO TERMINAL 1, GROUNDSS GROUND ON TRANSMITTER END, COIL WIRE CONNECTION FOR.

GROUND SHIELD CONNECTED TO GROUNDSS. SEE DETAIL "A" FOR ELECT PROOF WIRE CONNECTION.

SEE WIRING NOTE FOR DRAIN/SHIELD CONNECTION AT FLOWTUBE

SEE WIRING NOTE FOR DRAIN/SHIELD CONNECTION AT FLOWTUBE

**8750W TRANSMITTER OUTPUT AND POWER WIRING**

ANALOG 4-20 mA

TERMINAL 10

TERMINAL 20

TERMINAL 30

TERMINAL 21

TERMINAL 22

TERMINAL 23

TERMINAL 24

**REVISION TABLE**

REVISION	DATE	BY	CHKD.	DESCRIPTION
1	03/15/16	...	...	...

**DETAIL "A"**

14-16 AWG ELECTRIC TUBING

17-ELECT TUBING SHIELD/DRAIN

ALPHA DIRECT PAPER NUMBER

ALPHA EQUIVALENT 24-2C

**DETAIL "B"**

14-16 AWG ELECTRIC TUBING

3-16-18 AWG COIL WIRE DRAIN

ALPHA DIRECT

ALPHA EQUIVALENT 24-2C

ALPHA EQUIVALENT 24-2C

**WIRING NOTE**

DRAIN/SHIELD OF COIL WIRE TERMINAL 30 AND DRAIN/SHIELD OF FLEET TUBE TERMINAL 21 AND 22 MUST BE CONNECTED TO GROUNDSS. AN ADDITIONAL CONNECTED CABLE SHEET FOR COIL CABLES WILL BE REQUIRED FOR INSTALLATION-ENCLOSURE SHIELDS GROUNDSS BY GROUNDSS-EARTH RESISTANCE AT EACH END OF THE SHEET GROUND AT THE DEVICE WITH RESPECT TO THE EARTH SURFACE GROUND.

SEE DETAIL "B" FOR COIL WIRE DRIVE WIRE CONNECTION.

SEE DETAIL "B" FOR COIL WIRE DRIVE WIRE CONNECTION.

**8750W TRANSMITTER OUTPUT AND POWER WIRING**

ANALOG 4-20 mA

TERMINAL 10

TERMINAL 20

TERMINAL 30

TERMINAL 21

TERMINAL 22

TERMINAL 23

TERMINAL 24

**8750W TRANSMITTER OUTPUT AND POWER WIRING**

ANALOG 4-20 mA

TERMINAL 10

TERMINAL 20

TERMINAL 30

TERMINAL 21

TERMINAL 22

TERMINAL 23

TERMINAL 24

**8750W TRANSMITTER OUTPUT AND POWER WIRING**

ANALOG 4-20 mA

TERMINAL 10

TERMINAL 20

TERMINAL 30

TERMINAL 21

TERMINAL 22

TERMINAL 23

TERMINAL 24

**8750W TRANSMITTER OUTPUT AND POWER WIRING**

ANALOG 4-20 mA

TERMINAL 10

TERMINAL 20

TERMINAL 30

TERMINAL 21

TERMINAL 22

TERMINAL 23

TERMINAL 24

**8750W TRANSMITTER OUTPUT AND POWER WIRING**

ANALOG 4-20 mA

TERMINAL 10

TERMINAL 20

TERMINAL 30

TERMINAL 21

TERMINAL 22

TERMINAL 23

TERMINAL 24

**8750W TRANSMITTER OUTPUT AND POWER WIRING**

ANALOG 4-20 mA

TERMINAL 10

TERMINAL 20

TERMINAL 30

TERMINAL 21

TERMINAL 22

TERMINAL 23

TERMINAL 24











### Global Headquarters

#### Emerson Process Management

6021 Innovation Blvd.  
Shakopee, MN 55379, USA  
+1 800 522 6277 or +1 303 527 5200  
+1 303 530 8459  
Flow.Support@Emerson.com

### North America Regional Office

#### Emerson Process Management

7070 Winchester Circle  
Boulder, CO 80301, USA  
+1 800 522 6277 or +1 303 527 5200  
+1 303 530 8459  
Flow.Support@Emerson.com

### Latin America Regional Office

#### Emerson Process Management

Multipark Office Center  
Turubares Building, 3rd & 4th floor  
Guachipelin de Escazu, Costa Rica  
+1 506 2505 6962  
+1 954 846 5121  
Flow.Support@Emerson.com

### Europe Regional Office

#### Emerson Process Management Flow B.V.

Neonstraat 1  
6718 WX Ede  
The Netherlands  
+31 (0) 318 495555  
+31 (0) 318 495556  
Flow.Support@Emerson.com

### Asia Pacific Regional Office

#### Emerson Process Management Asia Pacific Pte Ltd

1 Pandan Crescent  
Singapore 128461  
+65 6777 8211  
+65 6777 0947  
APFlow.Support@Emerson.com

### Middle East and Africa Regional Office

#### Emerson Process Management

Emerson FZE P.O. Box 17033,  
Jebel Ali Free Zone - South 2  
Dubai, United Arab Emirates  
+971 4 8118100  
+971 4 8865465  
FlowTechnicalSupport@Emerson.com



[Linkedin.com/company/Emerson-Process-Management](https://www.linkedin.com/company/Emerson-Process-Management)



[Twitter.com/Rosemount\\_News](https://twitter.com/Rosemount_News)



[Facebook.com/Rosemount](https://www.facebook.com/Rosemount)



[Youtube.com/user/RosemountMeasurement](https://www.youtube.com/user/RosemountMeasurement)



[Google.com/+RosemountMeasurement](https://www.google.com/+RosemountMeasurement)

Standard Terms and Conditions of Sale can be found at

[Emerson.com/en-us/pages/Terms-of-Use.aspx](https://www.emerson.com/en-us/pages/Terms-of-Use.aspx)

The Emerson logo is a trademark and service mark of Emerson Electric Co.

Rosemount and Rosemount logotype are trademarks of Emerson Process Management

HART is a registered trademark of FieldComm Group.

Modbus is a registered trademark of Modicon, Inc.

All other marks are the property of their respective owners.

© 2016 Emerson Process Management. All rights reserved.