

Emerson™ Wireless 775 THUM™ Adapter



WirelessHART



EMERSON™

Contents

Section 1: Introduction

1.1	Using the manual	1
1.2	Features	2
1.3	Considerations	2
1.3.1	General	2
1.3.2	Commissioning	2
1.3.3	Mechanical	2
1.3.4	Electrical	2
1.3.5	Environmental	2
1.3.6	Wireless considerations	3
1.4	Product recycling/disposal	4

Section 2: Configuration

2.1	Safety messages	5
2.2	Connections	5
2.3	Device sensor configuration	5
2.4	Connection diagrams	6
2.5	Device network configuration	7
2.5.1	Join device to network	7
2.5.2	Configure update rate	7
2.5.3	Configure THUM Adapter long tag	8
2.5.4	Wired device tag	8
2.6	HART tree	9

Section 3: Mounting

3.1	Safety messages	11
3.2	Mounting	12
3.2.1	Direct mount	12
3.2.2	Remote mount	13
3.2.3	Power supply	13
3.2.4	Load resistor	13
3.2.5	Wiring	13
3.3	Loop current test	24

Section 4: Commissioning

4.1	Safety messages	27
4.2	Device network configuration	27
4.2.1	Network status	28
4.2.2	Verify operation	29

Section 5: Operation and maintenance

5.1	Safety messages	31
5.2	Startup sequence	31
5.3	Advanced setup.....	32
5.3.1	Configure advanced update rate.....	32
5.3.2	4-20 mA current	32
5.3.3	Voltage drop	32
5.3.4	Discovery mode	32
5.3.5	Configure HART polling.....	33
5.3.6	Configure router only mode.....	33
5.3.7	HART address	33
5.3.8	HART master	33

Section 6: Troubleshooting

6.1	Overview	35
6.2	Service support	37

Appendix A: Specifications and Reference Data

A.1	Functional specifications.....	39
A.2	Physical specifications	39
A.3	Performance specifications.....	40
A.4	Dimensional drawings	41
A.5	Ordering information.....	43
A.6	Accessories and spare parts	44

Appendix B: Product Certifications

B.1	European Directive Information.....	45
B.2	Ordinary Location Certification from FM Approvals.....	45
B.3	Telecommunication compliance (for wireless products only).....	45
B.4	FCC and IC (for wireless products only)	45
B.5	Installing Equipment in North America.....	45
B.6	USA	45

B.7	Canada	46
B.8	Europe.....	46
B.9	International	46
B.10	Brazil	46
B.11	China.....	47
B.12	Japan	47
B.13	EAC - Belarus, Kazakhstan, Russia	47
B.14	Republic of Korea	47
B.15	India.....	47
B.16	Combinations	47

Emerson™ Wireless 775 THUM™ Adapter

Emerson Wireless 775 THUM Adapter Hardware Revision	1
HART® Device Revision	1
Field Communicator Field Device Revision	Dev v2.5 DD v4

NOTICE

Read this manual before working with the product. For personal and system safety, and for optimum product performance, make sure to thoroughly understand the contents before installing, using, or maintaining this product.

The United States has two toll-free assistance numbers and one international number.

Customer Central

1 800 999 9307 (7:00 a.m. to 7:00 p.m. CST)

National Response Center

1 800 654 7768 (24 hours a day)

Equipment service needs

International

1 952 906 8888

CAUTION

The products described in this document are NOT designed for nuclear-qualified applications.

Using non-nuclear qualified products in applications that require nuclear-qualified hardware or products may cause inaccurate readings.

For information on Rosemount nuclear-qualified products, contact an Emerson Sales Representative.

WARNING

Explosions could result in death or serious injury.

Installation of this transmitter in an explosive environment must be in accordance with the appropriate local, national, and international standards, codes, and practices. Review the Product Certifications section for any restrictions associated with a safe installation.

- Before connecting a Field Communicator in an explosive atmosphere, ensure the instruments are installed in accordance with intrinsically safe or non-incendive field wiring practices.

Electrical shock can result in death or serious injury.

- Avoid contact with the leads and terminals. High voltage that may be present on leads can cause electrical shock.

This device complies with Part 15 of the FCC Rules. Operation is subject to the following conditions. This device may not cause harmful interference. This device must accept any interference received, including interference that may cause undesired operation.

This device must be installed to ensure a minimum antenna separation distance of 20 cm from all persons.

NOTICE

The THUM Adapter and all other wireless devices should be installed only after the Emerson Wireless Gateway has been installed and is functioning properly. Wireless devices should also be powered up in order of proximity from the Gateway, beginning with the closest. This will result in a simpler and faster network installation.

During normal operation, or in fault condition, the THUM Adapter will cause a 2.5 V drop in the connected loop. It is important to ensure that the power supply can provide at least 2.5 V more than the lift off voltage of the wired device to make sure it works properly with the THUM Adapter installed. To determine the lift off voltage for the wired device, review the wired device operation and installation manual.

Section 1 Introduction

1.1 Using the manual

This manual is designed to assist in the installation, operation, and maintenance of the Emerson™ Wireless 775 THUM™ Adapter.

Section 1: Introduction

- Manual and transmitter overview
- Considerations

Section 2: Configuration

- Device Sensor Configuration
- Device Network Configuration

Section 3: Mounting

- Mount the Sensor
- Sensor Assembly/Leads
- Grounding

Section 4: Commissioning

- Network Status
- Verify Operation

Section 5: Operation and maintenance

- Startup Sequence
- Advanced Setup

Section 6: Troubleshooting

- Troubleshooting recommended actions
- Service support

Appendix A: Specifications and Reference Data

- Specifications
- Dimensional Drawings
- Ordering Information

Appendix B: Product Certifications

- Product Certifications
- Installation Drawings

1.2 Features

- An installation-ready solution that provides rich wireless HART® data
- Works with any 2- or 4-wire HART devices
- Flexibility to meet your most demanding applications
- Wireless output with >99% data reliability delivers rich HART data, protected by industry leading security
- Gain access to additional HART information, such as diagnostics or multi-variable data
- Add wireless to almost any measurement point without affecting the approval of the sub-device
- IEC 62591 (*WirelessHART*®) capabilities extend the full benefits of Plantweb™ to previously inaccessible locations

1.3 Considerations

1.3.1 General

The THUM Adapter is connected to a HART sub-device. With simple HART configuration, the THUM transmits the HART information from the sub-device into the Wireless network.

1.3.2 Commissioning

The THUM Adapter can be commissioned before or after installation. It may be useful to bench commission the THUM Adapter before installation to ensure proper operation and to become familiar with the functionality. The instruments should be installed in accordance with intrinsically safe or non-incendive field wiring practices, when required. The THUM Adapter is powered when connected to a powered loop.

1.3.3 Mechanical

When choosing an installation location and position for the transmitter, take into account access to the device. For best performance, the antenna should be vertical and have some space between objects in a parallel metal plane such as a pipe or metal framework, as the pipes or framework may adversely affect the performance of the antenna.

1.3.4 Electrical

The THUM Adapter is connected into a powered 4–20 mA loop, powering itself by scavenging power. The THUM Adapter causes a voltage drop across the loop. The drop is linear from 2.25 volts at 3.5 mA to 1.2 volts at 25 mA, but does not effect the 4–20 mA signal on the loop. Under fault conditions, the maximum voltage drop is 2.5 volts.

1.3.5 Environmental

Verify that the operating environment of the transmitter is consistent with the appropriate hazardous locations certifications.

Temperature limits

Operating limit	Storage limit
-40 to 185 °F	-40 to 185 °F
-40 to 85 °C	-40 to 85 °C

1.3.6 Wireless considerations

Power up sequence

Power should not be applied to any wireless device until the Gateway is installed and functioning properly. Wireless devices should also be powered up in order of proximity from the Gateway, beginning with the closest. This will result in a simpler and faster network installation. Enable active advertising on the Gateway to ensure that new devices join the network faster. For more information see the Emerson Wireless 1420 Gateway [Reference Manual](#).

THUM Adapter position

If possible, the THUM Adapter should be positioned vertically, either straight up or straight down, and it should be approximately 3 ft. (1 m) from any large structure, building, or conductive surface to allow for clear communication to other devices. If the THUM Adapter is mounted horizontally, wireless communication range may be decreased.

Figure 1-1. THUM Adapter Position

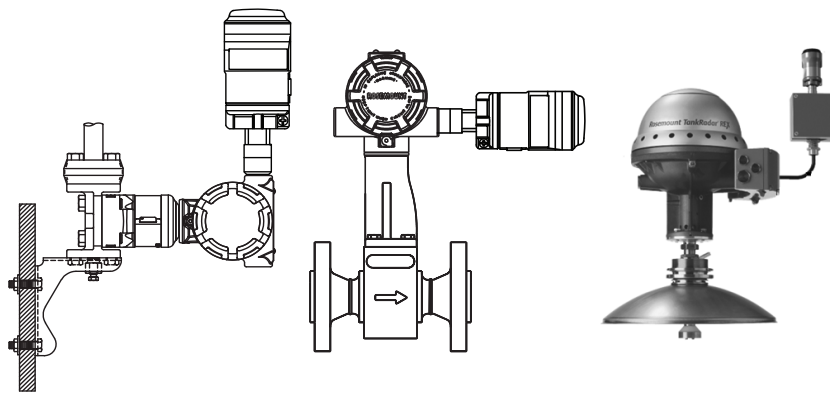

Conduit entry

When installing the THUM Adapter into the conduit entry of a wired device, use an approved thread sealant. Thread sealant provides a water tight seal. The thread sealant also provides a lubrication to ensure easy removal of the THUM Adapter.

M20 conduit adapter

When using the M20 Conduit Adapter on the THUM Adapter, use an approved thread sealant and tighten wrench tight to the THUM Adapter. When installing the M20 conduit adapter into a conduit tighten to 32.5 Nm/25 ft-lb. to ensure water tight seal.

Field Communicator connections

In order for the Field Communicator to interface with the THUM Adapter, the wired device must be powered. The Field Communicator must be put into poll mode and should use the THUM Adapter address of 63.

Power supply

Minimum loop load of 250 Ohms.

The THUM Adapter communicates and derives power from a standard 4-20 mA/HART loop. The THUM Adapter causes a small voltage drop on the loop which is linear from 2.25 V at 3.5 mA to 1.2 V at 25 mA. Under fault conditions, the maximum voltage drop is 2.5 V. The THUM Adapter will not affect the 4–20 mA signal under normal or fault conditions as long as the loop has at least a 2.5 V margin at the maximum loop current (25 mA for a typical 4-20 mA/HART device).

Limit the power supply to 0.5 Amps maximum, and voltage to 55 Vdc.

Loop current	THUM Adapter voltage drop
3.5 mA	2.25 V
25 mA	1.2 V

Load resistor

If required, add a load resistor as shown in [Figure 3-20](#), [Figure 3-22](#), and [Figure 3-24](#). The resistor should be adequately rated for the application (1W minimum) and be compatible with the supplied splice connector which accepts wire sizes from 14 to 22 AWG.

When adding a load resistor, ensure that uninsulated conductors do not contact the enclosure and/or other exposed metal parts.

1.4 Product recycling/disposal

Recycling of equipment and packaging should be taken into consideration and disposed of in accordance with local and national legislation/regulations.

Section 2 Configuration

Safety messages	page 5
Connections	page 5
Device sensor configuration	page 5
Connection diagrams	page 6
Device network configuration	page 7
HART tree	page 9

2.1 Safety messages

Instructions and procedures in this section may require special precautions to ensure the safety of the personnel performing the operations. Information that potentially raises safety issues is indicated by a warning symbol (⚠). Please refer to the following safety messages before performing an operation preceded by this symbol.

⚠ WARNING

Failure to follow these installation guidelines could result in death or serious injury.

- Only qualified personnel should perform the installation

Explosions could result in death or serious injury.

- Before connecting a field communicator in an explosive atmosphere, make sure that the instruments are installed in accordance with intrinsically safe or non-incendive field wiring practices
- Verify that the operating atmosphere of the transmitter is consistent with the appropriate hazardous locations certifications

Electrical shock could cause death or serious injury.

- Use extreme caution when making contact with the leads and terminals

This device complies with Part 15 of the FCC Rules. Operation is subject to the following conditions: This device may not cause harmful interference. This device must accept any interference received, including interference that may cause undesired operation.

This device must be installed to ensure a minimum antenna separation distance of 20 cm from all persons.

2.2 Connections

Section 2 details wiring the Emerson™ Wireless 774 THUM™ Adapter to the different types of compatible sub-devices.

2.3 Device sensor configuration

The THUM Adapter, attached to a powered sub-device, receives HART® Communication from a Field Communicator or AMS Device Manager.

Field Communicator

In order to communicate with the THUM Adapter, polling must be activated on the Field Communicator. The default address for the THUM Adapter is 63. Also, note that any configuration changes must be sent to the transmitter using the Send key (F2).

AMS Wireless Configurator

AMS Wireless Configurator is capable of connecting devices directly using a HART modem or the Gateway. For configuring through AMS Wireless Configurator, double click the device icon and select the **Configure/Setup** tab. AMS Configuration changes are implemented when the **Apply** button is selected.

2.4 Connection diagrams

Bench hook-up

Connect the bench equipment as shown in either [Figure 2-1](#) or [Figure 2-2](#), and turn on the field communicator by pressing the **ON/OFF** key or log into AMS Device Manager. The Field Communicator or AMS Device Manager will search for a HART-compatible device and indicate when the connection is made. If the Field Communicator or AMS Device Manager fail to connect, it indicates that no device was found. If this occurs, refer to [Section 4: Commissioning](#).

Field hook-up

[Section 2: Configuration](#) details the field hook-up requirements in [Figure 2-1](#) and [Figure 2-2](#).

Figure 2-1. THUM Adapter Only, Powered by a Current Source

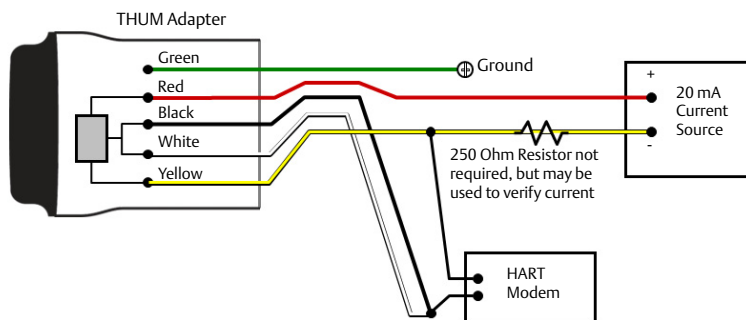
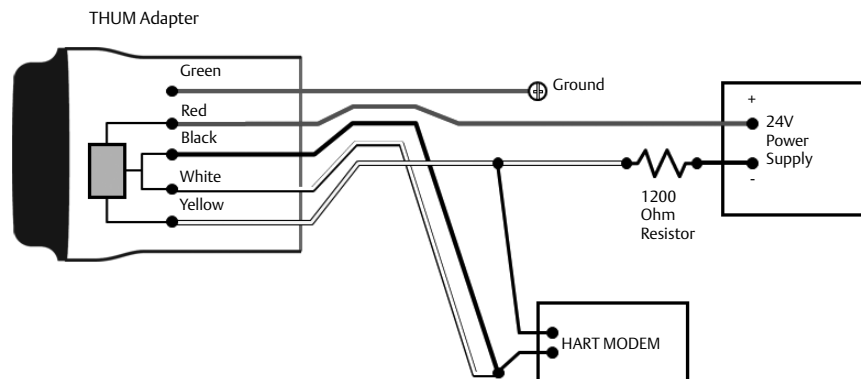

Figure 2-2. THUM Adapter Only, Powered by a 24 V Power Supply with 1200 Ohm Resistor To Limit Current to 20 mA



The 1200 Ohm resistor should be adequately rated for the application (3 W minimum).

2.5 Device network configuration

2.5.1 Join device to network

Fast Keys	2, 1, 1
------------------	---------

In order to communicate with the Emerson Wireless Gateway, and ultimately the Host System, the THUM must be configured to communicate over the wireless network. This step is the wireless equivalent of connecting wires from a transmitter to the host system.

1. From the *Home* screen, select **2: Configure**.
2. Select **1: Guided Setup**.
3. Select **1: Join Device to Network**.

Using a field communicator or AMS Device Manager, enter the Network ID and Join Key so that they match the Network ID and Join Key of the Gateway and other devices in the network. If the Network ID and Join Key are not identical to those set in the Gateway, the THUM Adapter will not communicate with the network. The Network ID and Join Key may be obtained from the Gateway on the *Setup>Network>Settings* page on the web server.

2.5.2 Configure update rate

Fast Keys	2, 1, 2
------------------	---------

The Update Rate is the frequency at which a new measurement is taken and transmitted over the wireless network. This by default is one minute. This may be changed at commissioning, or at any time via AMS Wireless Configurator. The Update Rate is user selectable from eight seconds to 60 minutes.

1. From the Home screen, select **2: Configure**.
2. Select **1: Guided Setup**.
3. Select **2: Configure Update Rate**.

2.5.3 Configure THUM Adapter long tag

Fast Keys	2, 2, 4, 2
------------------	------------

The Long Tag is how the THUM Adapter will show up in the Gateway web interface. By setting this parameter to a unique value it will be easier to determine which THUM Adapter you are communicating with. One way to do this is to use the tag number of the wired device that the THUM adapter is connected to followed by THUM (HARTTAG-THUM).

1. From the *Home* screen, select **2: Configure**.
2. Select **1: Manual Setup**.
3. Select **2: Device Information tab**.
4. Enter the Long Tag.

2.5.4 Wired device tag

For HART 5 devices the THUM Adapter uses the message field when reporting the HART tag to the Gateway. To ensure that you can identify the wired device in the Gateway make sure to write the tag information into the message field for all HART 5 devices. For HART 6 or newer devices the THUM Adapter reports the long tag as the HART tag to the Gateway.

2.6 HART tree

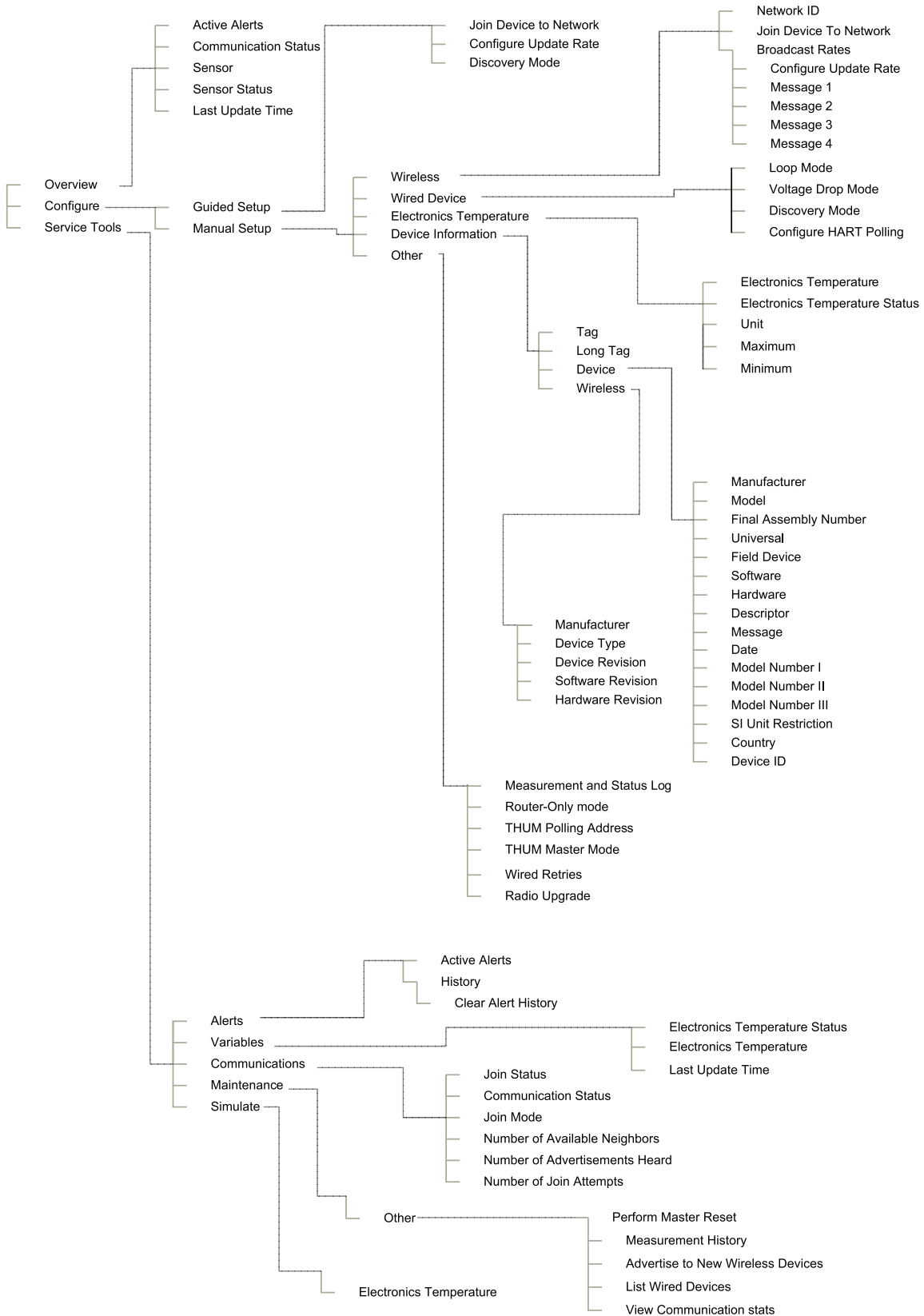

Section 3 Mounting

Safety messages	page 11
Mounting	page 12
Loop current test	page 24

3.1 Safety messages

Instructions and procedures in this section may require special precautions to ensure the safety of the personnel performing the operations. Information that potentially raises safety issues is indicated by a warning symbol (⚠). Please refer to the following safety messages before performing an operation preceded by this symbol.

⚠ WARNING

Failure to follow these installation guidelines could result in death or serious injury.

- Only qualified personnel should perform the installation

Explosions could result in death or serious injury.

- Before connecting a field communicator in an explosive atmosphere, make sure that the instruments are installed in accordance with intrinsically safe or non-incendive field wiring practices
- Verify that the operating atmosphere of the transmitter is consistent with the appropriate hazardous locations certifications

Electrical shock could cause death or serious injury.

- Use extreme caution when making contact with the leads and terminals

This device complies with Part 15 of the FCC Rules. Operation is subject to the following conditions: This device may not cause harmful interference. This device must accept any interference received, including interference that may cause undesired operation.

This device must be installed to ensure a minimum antenna separation distance of 20 cm from all persons.

3.2 Mounting

The Emerson™ Wireless 775 THUM™ Adapter can be installed in one of two configurations:

- Direct mount
- Remote mount

Direct mount: The THUM Adapter is connected directly to the conduit entry of the wired device.

Figure 3-1. Direct Mount

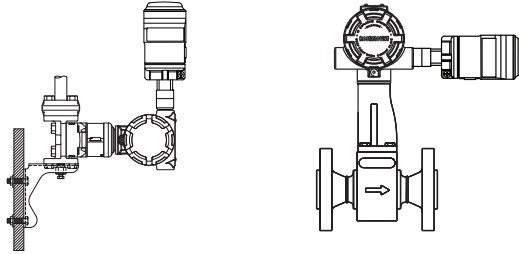

3.2.1 Direct mount

1. Install the HART® device according to standard installation practices, being sure to use an approved thread sealant on all connections.
2. Attach the THUM Adapter to the wired device as shown in [Figure 3-1](#). When installing the THUM Adapter into the conduit entry of a wired device, use an approved thread sealant.
3. Connect the THUM Adapter to the HART wired device using the wiring diagrams below. See [Figure 3-19](#) through [Figure 3-26](#) on the following pages.
4. Close the housing cover on the HART wired device, so that metal touches metal, but do not over tighten to prevent damaging the unit.

Note

Two splice connectors are included with the THUM Adapter. The first is a two connection splice. The second is a three connection splice for use with a resistor, if there is not enough resistance in the loop. Both of these splice connectors can accept 14 to 22 gauge wire. See wired device reference manual for information on the required loop resistance.

Remote mount: The THUM Adapter is mounted separate from the wired device housing and then connected to the wired device using conduit.

Figure 3-2. Remote Mount

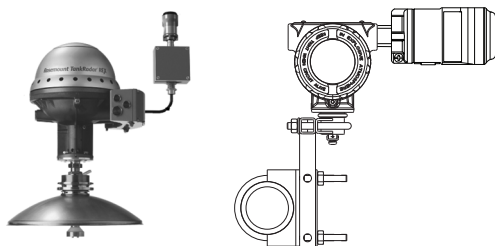

3.2.2 Remote mount

1. Install the HART device according to standard installation practices, being sure to use an approved thread sealant on all connections.
2. The THUM Adapter should be mounted as shown in [Figure 3-2 on page 12](#).
3. Connect the THUM Adapter to the wired device using standard practices. Wire running from the THUM Adapter to the wired device must be shielded or in conduit.
4. Ground the Remote Mount Kit per local practices.
5. Connect the THUM Adapter to the HART wired device using the wiring diagrams below. See [Figure 3-19](#) through [Figure 3-26](#) on the following pages.
6. Close the housing cover on the HART wired device, so that metal touches metal, but do not over tighten to prevent damaging the unit.

Note

Two splice connectors are included with the THUM Adapter. The first is a two connection splice. The second is a three connection splice for use with a resistor, if there is not enough resistance in the loop. Both of these splice connectors can accept 14 to 22 gauge wire. See wired device reference manual for information on the required loop resistance.

3.2.3 Power supply

Minimum loop load of 250 Ohms.

The THUM Adapter communicates and derives power from a standard 4-20 mA/HART loop. The THUM Adapter causes a small voltage drop on the loop which is linear from 2.25 V at 3.5 mA to 1.2 V at 25 mA. Under fault conditions, the maximum voltage drop is 2.5 V. The THUM Adapter will not affect the 4-20 mA signal under normal or fault conditions as long as the loop has at least a 2.5 V margin at the maximum loop current (25 mA for a typical 4-20 mA/HART device).

Limit the power supply to 0.5 Amps maximum, and voltage to 55 Vdc.

Loop current	THUM Adapter voltage drop
3.5 mA	2.25 V
25 mA	1.2 V

3.2.4 Load resistor

If required, add a load resistor as shown in [Figure 3-20](#), [Figure 3-22](#), and [Figure 3-24](#). The resistor should be adequately rated for the application (1W minimum) and be compatible with the supplied splice connector which accepts wire sizes from 14 to 22 AWG.

3.2.5 Wiring

Note

In order for the THUM Adapter to function properly there must be at least 250 Ohms resistance in the loop. If the 4–20 mA loop does not have the required resistance, wire a resistor as shown in [Figure 3-20](#), [Figure 3-22](#), or [Figure 3-24](#) as applicable.

When adding a load resistor ensure that uninsulated conductors do not contact the enclosure and/or other exposed metal parts.

Figure 3-3. Direct Mount Wiring Diagram for 2-wire Device

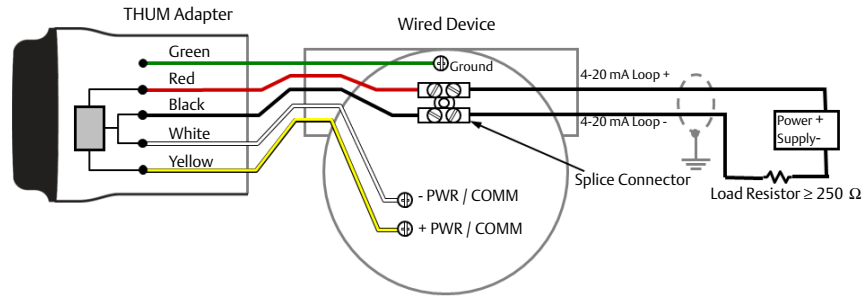

Note

In order for the THUM Adapter to function properly there must be at least 250 Ohms resistance in the loop. If the 4–20 mA loop does not have the required resistance, wire a resistor as shown in Figure 3-6, Figure 3-10, or Figure 3-13 as applicable.

Figure 3-4. Remote Mount Wiring Diagram for 2-wire Device

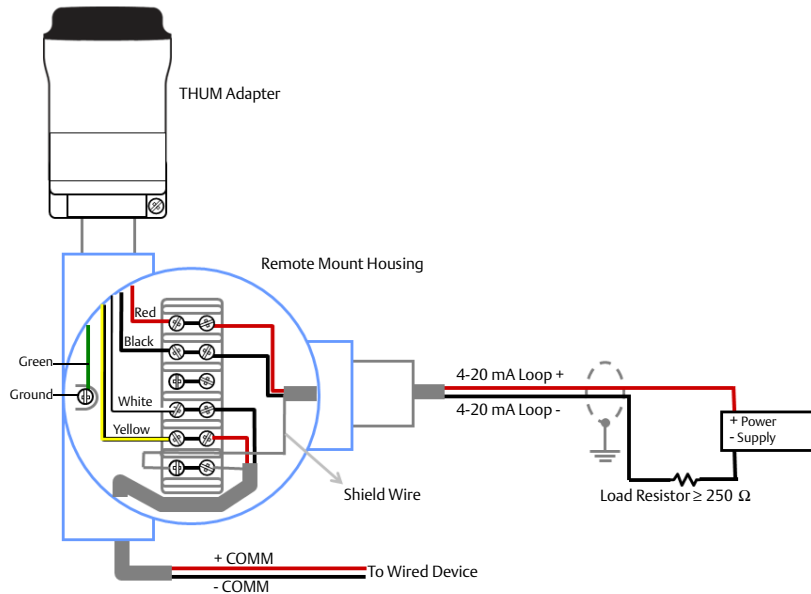

Figure 3-5. Direct Mount Wiring Diagram for 2-wire Device with Resistor

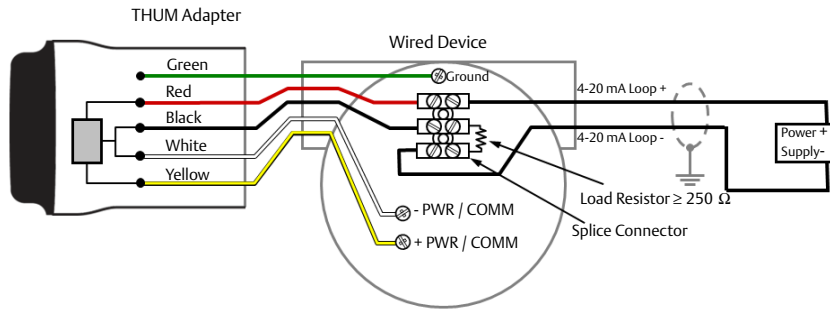

Figure 3-6. Remote Mount Wiring Diagram for 2-wire Device with Resistor

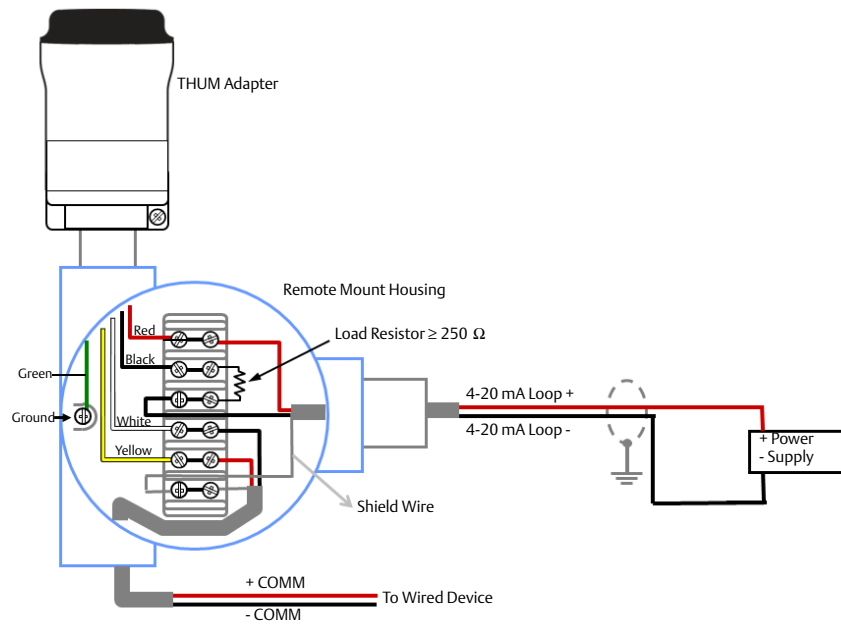
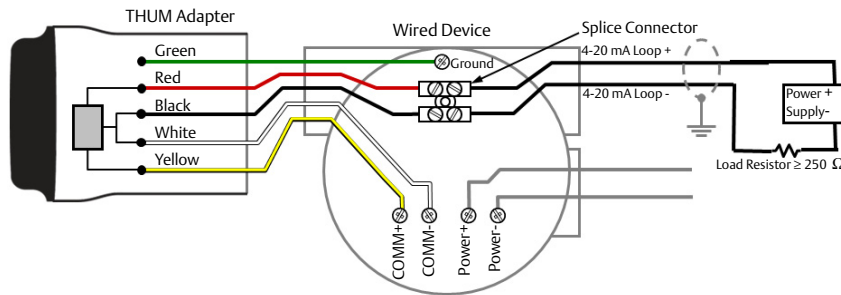

Figure 3-7. Direct Mount Wiring Diagram for 4-wire Passive Device



Note

A passive loop exists when the wired device is not supplying power to the 4–20 mA loop. It is important to verify if the wired device is operating in active or passive mode.

Figure 3-8. Remote Mount Wiring Diagram for 4-wire Passive Device

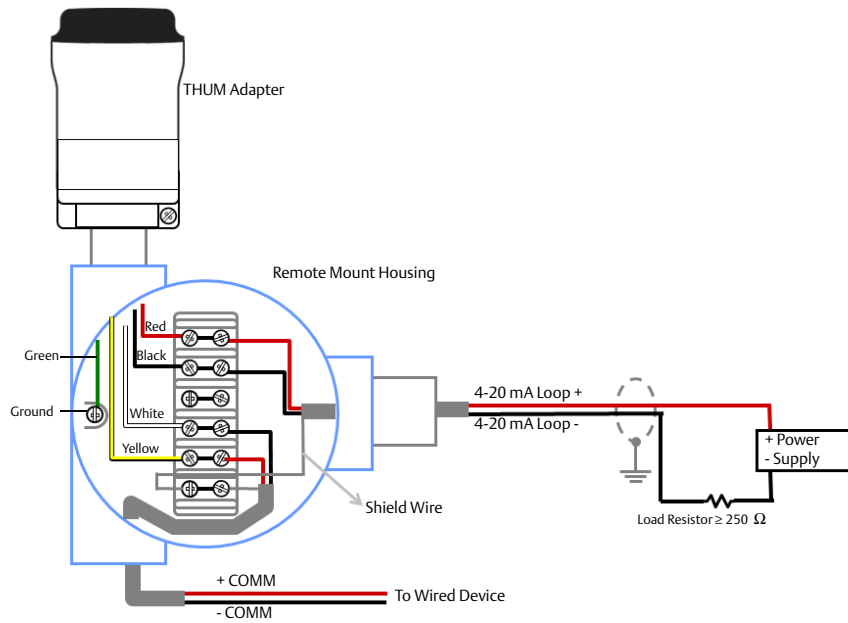

Figure 3-9. Direct Mount Wiring Diagram for 4-wire Passive Device with Resistor

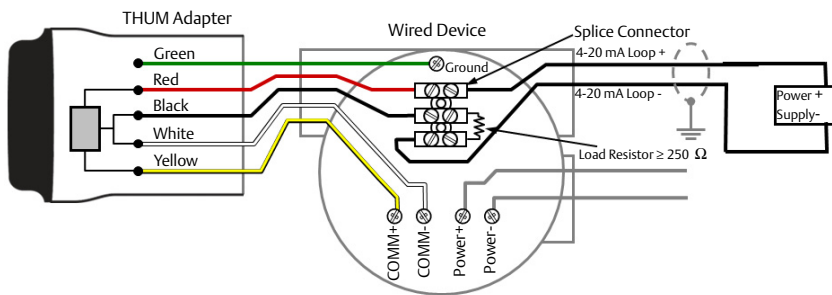

Figure 3-10. Remote Mount Wiring Diagram For 4-wire Passive Device with Resistor

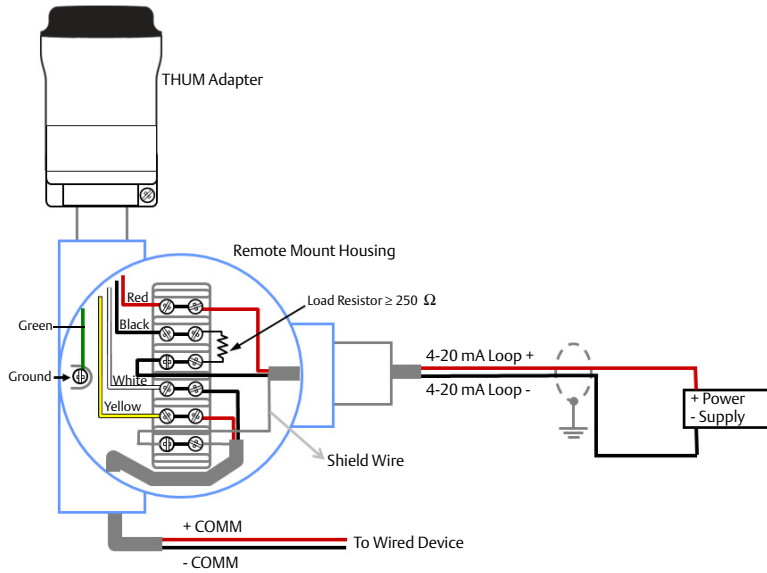
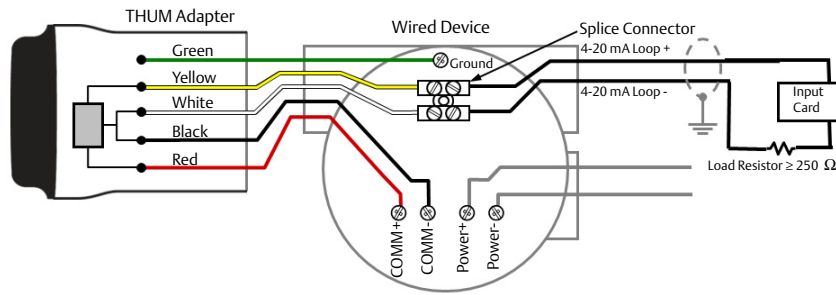

Figure 3-11. Direct Mount Wiring Diagram for 4-wire Active Device



Note

An active loop exists when the wired device is supplying the power to the 4–20 mA loop. It is important to verify if the wired device is operating in active or passive mode.

Figure 3-12. Remote Mount Wiring Diagram for 4-wire Active Device

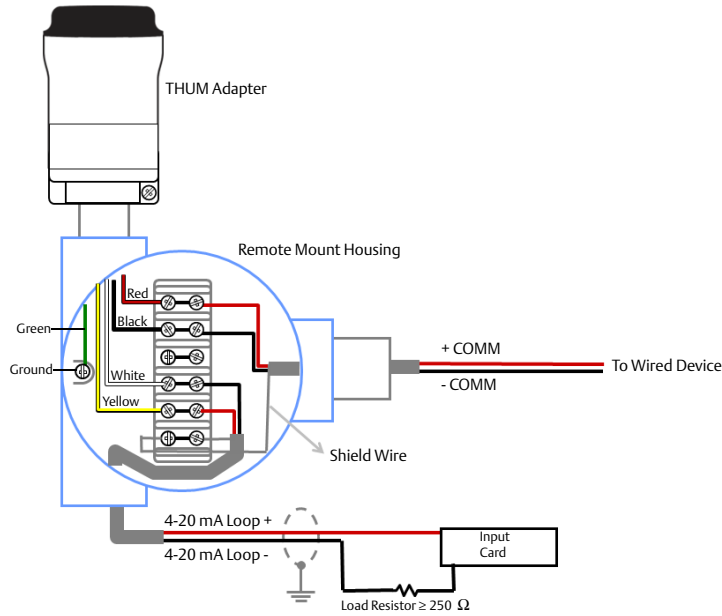

Figure 3-13. Direct Mount Wiring Diagram for 4-wire Active Device with Resistor

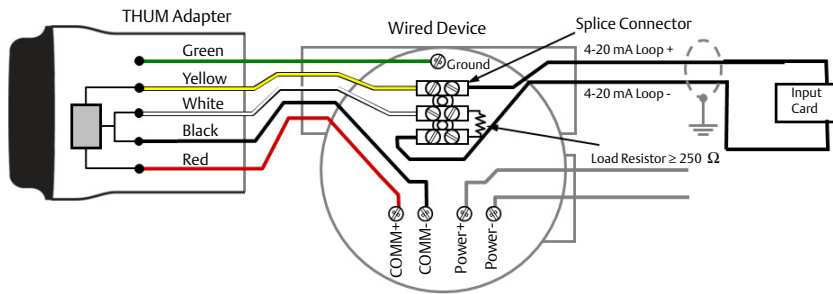

Figure 3-14. Remote Mount Wiring Diagram for 4-wire Active Device with Resistor

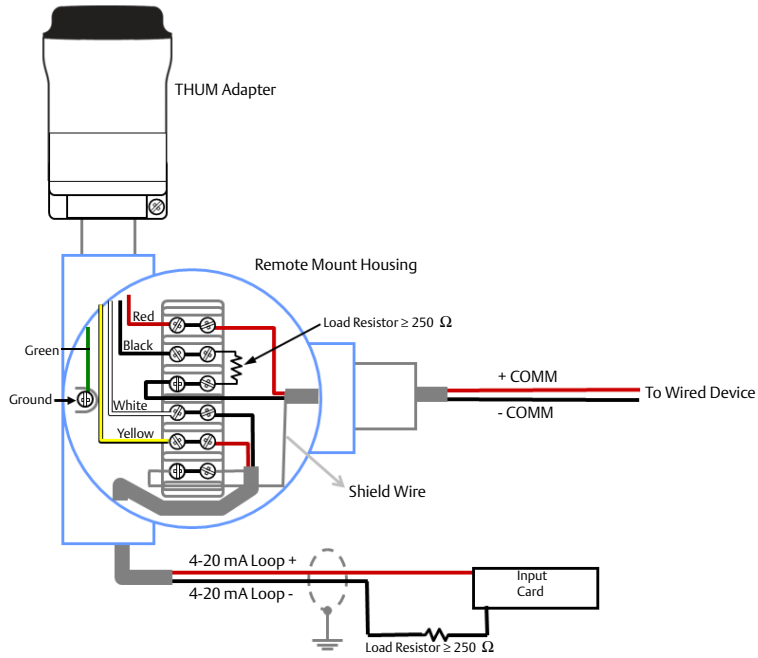

Figure 3-15. Direct Mount Wiring Diagram for 4-wire Active Device with No 4-20 mA Loop

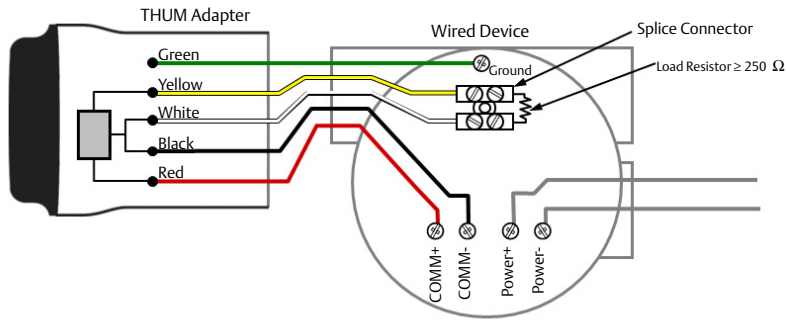

Figure 3-16. Remote Mount Wiring Diagram for 4-wire Active Device With No 4-20 mA Loop

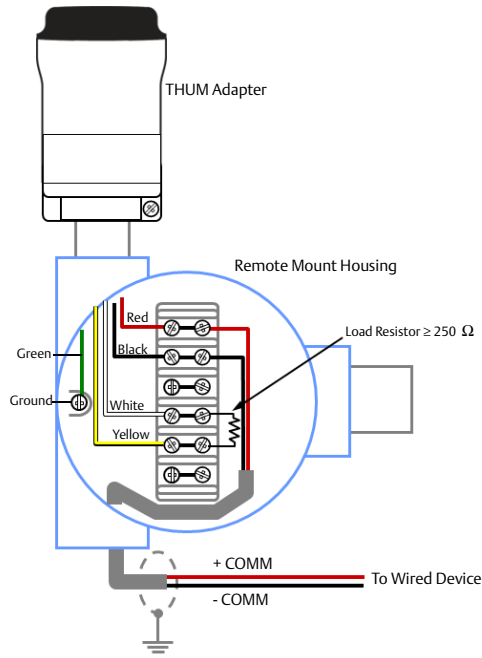

Figure 3-17. THUM Adapter Only, Powered by A 24 V Power Supply with 1200 Ohm Resistor to Limit Current to 20 mA

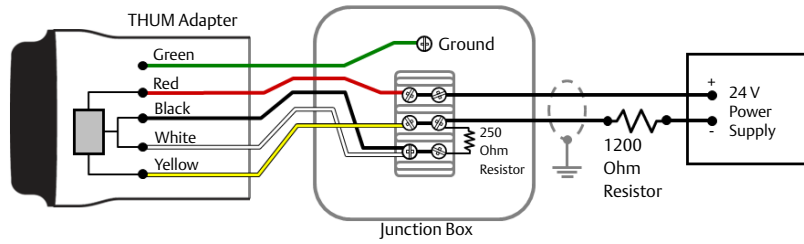

Figure 3-18. THUM Adapter Only, Powered by A 24 V Power Supply with 1200 Ohm Resistor to Limit Current to 20 mA

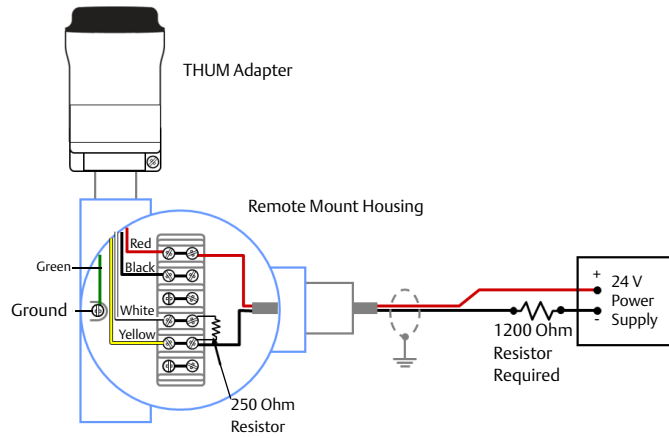

Figure 3-19. Wiring Diagram for 2-wire Device

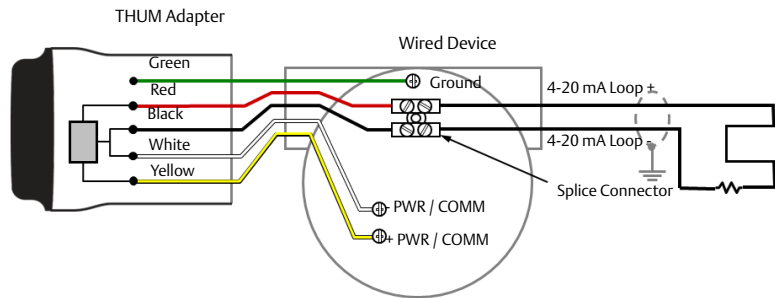
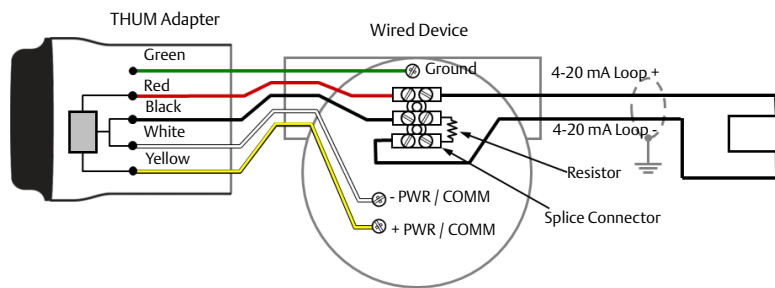

Figure 3-20. Wiring Diagram for 2-wire Device with Resistor



Note

A passive loop exists when the wired device is not supplying power to the 4-20 loop. It is important to verify if the wired device is operating in active or passive mode.

Figure 3-21. Wiring Diagram for 4-wire Passive Device

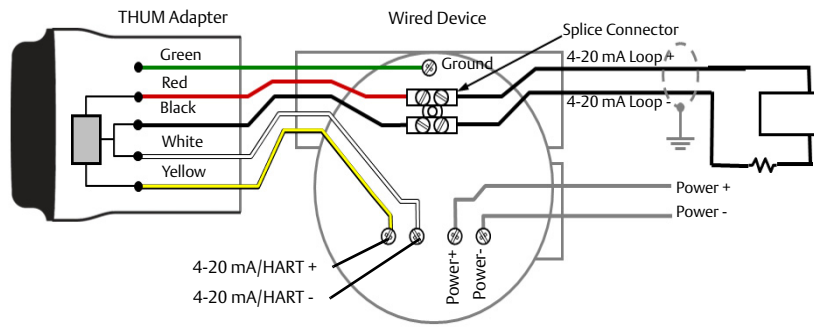
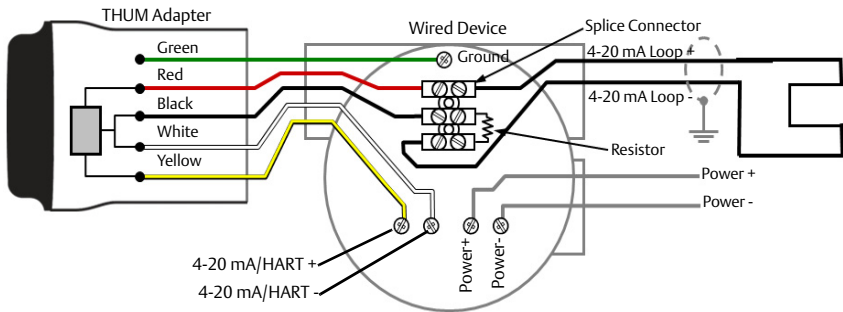

Figure 3-22. Wiring Diagram for 4-wire Passive Device With Resistor



Note

An active loop exists when the wired device is supplying power to the 4-20 mA loop. It is important to verify if the wired device is operating in an active or passive mode.

Figure 3-23. Wiring Diagram for 4-wire Active Device

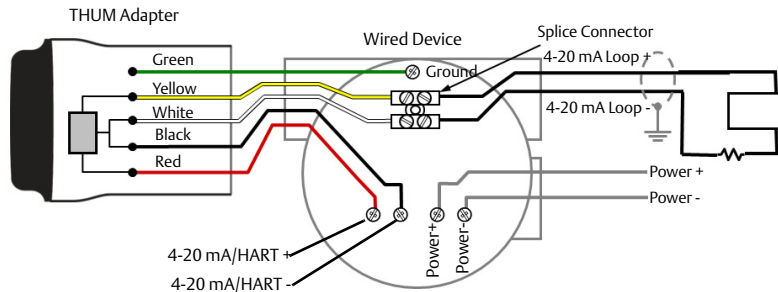

Figure 3-24. Wiring Diagram for 4-wire Active Device With Resistor

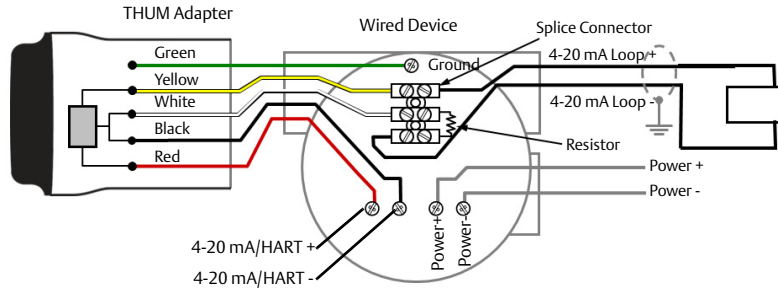

Figure 3-25. Wiring Diagram for 4-wire Active Device With No 4-20 Ma Loop

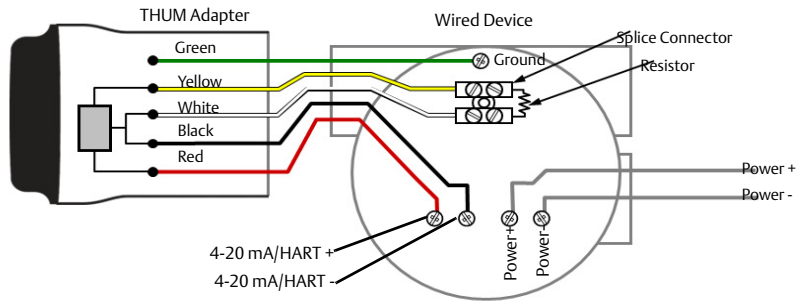
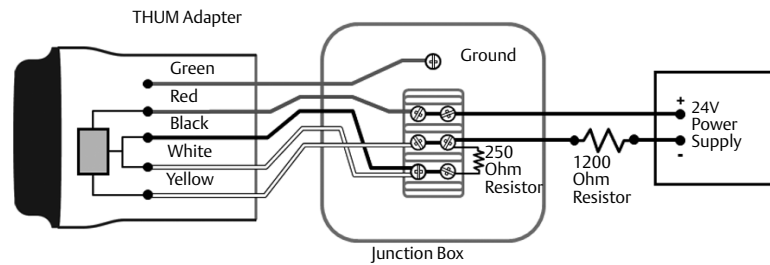

Figure 3-26. Wiring Diagram for Thum Adapter as Router, No Wired Device



The 1200 Ohm resistor should be adequately rated for the application (3Ω minimum).

3.3 Loop current test

To verify that the THUM Adapter will work under all conditions, a loop current test should be performed. This test will exercise the loop under the highest possible voltage drop conditions.

1. Place loop in manual control.
2. Drive loop to high alarm level. For details, see wired device instruction manual.
 - When the THUM Adapter is connected to a valve, this will need to be done at the current source and not from the valve.
 - When the THUM Adapter is connected to a transmitter, this will need to be performed at the transmitter.
3. Place the THUM Adapter into fixed voltage drop mode.

AMS Device Manager

Right click on the THUM Adapter and select **Configure**. When the menu opens, select **Manual Setup** from the window on the left and select the *Wired Device* tab on the top. Make sure that the *Time* drop down menu at the bottom of the page has **Current** selected. Under the *Voltage Drop* drop down menu in the *Smart Power Options* box, select **Fixed Voltage Drop**. Hit the **Apply** button to make any changes. See [Figure 3-27 on page 25](#).

Field Communicator

When communicating to the THUM Adapter select: **Configure > Manual setup > Wired Device > Voltage Drop Mode**. In the method select **Fixed Voltage Drop**.

Function	Key sequence	Menu items
Voltage Drop	2,2,2,2	Voltage Drop

4. Verify the current on the loop reaches the high alarm levels.
5. Place the THUM Adapter into variable voltage drop mode.

AMS Device Manager

Right click on the THUM Adapter and select **Configure**. When the menu opens, select **Manual Setup** from the window on the left and select the *Wired Device* tab on the top. Make sure the *Time* drop down menu at the bottom of the page has **Current** selected. Under the *Voltage Drop* drop down menu in the *Smart Power Options* box, select **Variable Voltage Drop**. Hit the **Apply** button to make any changes. See [Figure 3-27](#).

Field Communicator

When communicating to the THUM Adapter, select: **Configure > Manual setup > Wired Device > Voltage Drop Mode**. In the method select **Variable Voltage Drop**.

Function	Key sequence	Menu items
Voltage Drop	2,2,2,2	Voltage Drop

6. Remove loop from high alarm value.

Figure 3-27. AMS Device Manager Configure Screen

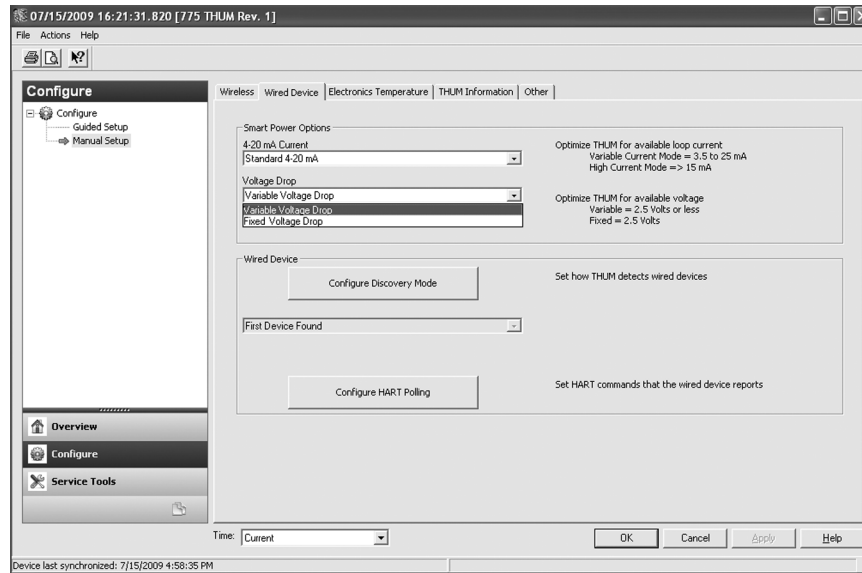

Section 4 Commissioning

Safety messages	page 27
Device network configuration	page 27

4.1 Safety messages

Instructions and procedures in this section may require special precautions to ensure the safety of the personnel performing the operations. Information that potentially raises safety issues is indicated by a warning symbol (⚠). Please refer to the following safety messages before performing an operation preceded by this symbol.

⚠ WARNING

Failure to follow these installation guidelines could result in death or serious injury.

- Only qualified personnel should perform the installation.

Explosions could result in death or serious injury.

- Before connecting a Field Communicator in an explosive atmosphere, make sure that the instruments are installed in accordance with intrinsically safe or non-incendive field wiring practices.
- Verify that the operating atmosphere of the transmitter is consistent with the appropriate hazardous locations certifications.

Electrical shock could cause death or serious injury.

- Use extreme caution when making contact with the leads and terminals.

This device complies with Part 15 of the FCC Rules. Operation is subject to the following conditions: This device may not cause harmful interference. This device must accept any interference received, including interference that may cause undesired operation.

This device must be installed to ensure a minimum antenna separation distance of 20 cm from all persons.

4.2 Device network configuration

In order to communicate with the Emerson™ Wireless Gateway, and ultimately the Information System, the transmitter must be configured to communicate with the wireless network. This step is the wireless equivalent of connecting wires from a transmitter to the information system. Using a Field Communicator or AMS Device Manager, enter the Network ID and Join Key so that they match the Network ID and Join Key of the Gateway and other devices in the network. If the Network ID and Join Key are not identical, the Emerson Wireless 775 THUM™ Adapter will not communicate with the network. The Network ID and Join Key may be obtained from the Gateway on the *Setup>Network>Settings* page on the web server, shown in [Figure 4-1](#).

Figure 4-1. Gateway Network Setting

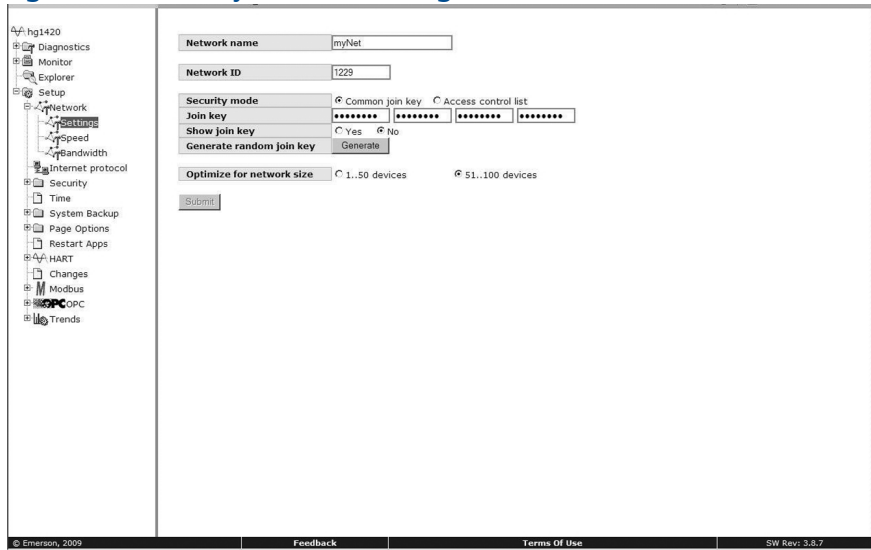

AMS Device Manager

Right click on the THUM Adapter and select **Configure**. When the menu opens, select **Join Device to Network** and follow the method to enter the Network ID and Join Key.

Field Communicator

The Network ID and Join Key may be changed in the wireless device by using the following Fast Key sequence. Set both Network ID and Join Key.

Operation can be verified in three locations: by using the Field Communicator, at the Gateway via the Gateway's integrated web server, or via AMS Wireless Configurator.

Function	Key sequence	Menu items
Wireless Setup	1, 4	Smart Power, Network ID, Set Join Key, <i>Radio State</i>

4.2.1 Network status

If the THUM Adapter was configured with the Network ID and Join Key and sufficient time for network polling has passed, the transmitter should be connected to the network. To verify connectivity, open the Gateway's integral web interface and navigate to the *Explorer* page.

HART Tag	HART status	Last update	PV	SV	TV	QV	Burst rate
5400-1004580	●	08/18/09 15:36:16	60.380 ft	5.236 ft	23.703 DegC	756.831 mV	00:01:00
5400-1004580-THUM	●	08/18/09 15:36:16	23.063 DegC				00:01:00

This page will display the THUM Adapter's HART tag, PV, SV, TV, QV, and Update Rate. A green status indicator means that the device is working properly. A red indicator means that there is a problem with either the device or its communication path. For more detail on a specific device, click on the tag name.

4.2.2 Verify operation

Operation can be verified in three locations: by using the Field Communicator, at the Gateway via the Gateway's integrated web server, or via AMS Wireless Configurator.

Field Communicator

In order for the THUM Adapter to communicate with a Field Communicator, a THUM Adapter DD is required. The Field Communicator must be put into a polling mode using the THUM adapter address of 63. Connect the Field Communicator to the wired device. The Field Communicator should find both the THUM Adapter and the wired device.

Table 4-1. Field Communicator Connections

Function	Key sequence	Menu items
Communications	3, 3	Join Status, Wireless Mode, Join Mode, Number of Available Neighbors, Number of Advertisements Heard, Number of Join Attempts

Gateway

If the THUM Adapter was configured with the Network ID and Join Key, and sufficient time has passed for network polling, the transmitter will be connected to the network. To verify device operation and connection to the network with the Gateway's integrated web server, open the Gateway's integral web interface and navigate to the *Explorer* page.

Note

It may take several minutes for the device to join the network.

AMS Wireless Configurator

When the device has joined the network, it will appear in the Wireless Configurator as illustrated below.

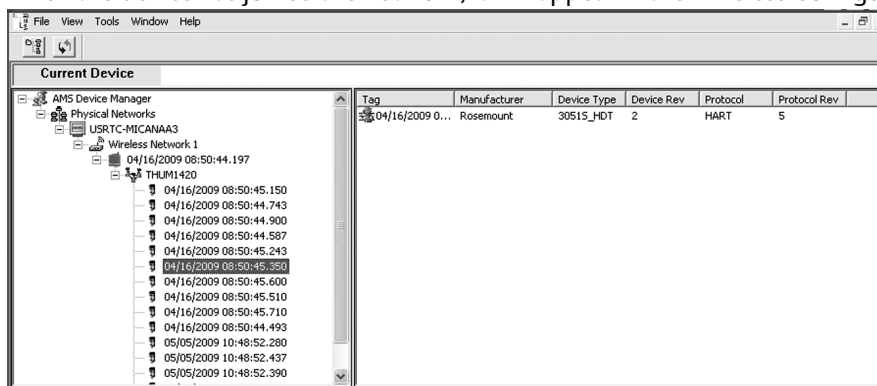

Troubleshooting

If the device is not operating properly, refer to the troubleshooting section of the manual. The most common cause of incorrect operation is the Network ID and Join Key. The Network ID and Join Key in the device must match that of the Gateway.

The Network ID and Join Key may be obtained from the Gateway on the *Setup>Network>Settings* page on the web server. The Network ID and Join Key may be changed in the wireless device by using the following Fast Key sequence.

Reference information

Function	Key sequence	Menu items
Wireless Setup	1, 4	Smart Power, Network ID, Set Join Key, Radio State

Note

In order to communicate with a Field Communicator, the wired device must be powered.

Table 4-2. THUM Adapter Hart Fast Key Sequence

Function	Key sequence	Menu items
Device Info	2, 2, 4, 3	Manufacturer, Model, Final Assembly Number, Universal, Field Device, Software, Hardware, Descriptor, Message, Date, Model Number I, II, III, SI Unit Restriction, Country
Guided Setup	2, 1	Configure, Guided Setup, Join Device to Network, Configure Update Rate, Zero Trim, Configure Device Display, Configure Process Alarms
Manual Setup	2, 2	Configure, Manual Setup, Wireless, Pressure, Device Temperatures, Device Information, Display, Other
Wireless	2, 2, 1	Network ID, Join Device to Network, Configure Update Rate, Configure Broadcast Power Level, Power Mode, Power Source

Section 5 Operation and maintenance

Safety messages	page 31
Startup sequence	page 31
Advanced setup	page 32

5.1 Safety messages

Instructions and procedures in this section may require special precautions to ensure the safety of the personnel performing the operations. Information that potentially raises safety issues is indicated by a warning symbol (⚠). Please refer to the following safety messages before performing an operation preceded by this symbol.

⚠ WARNING

Failure to follow these installation guidelines could result in death or serious injury.

- Only qualified personnel should perform the installation.

Explosions could result in death or serious injury.

- Before connecting a Field Communicator in an explosive atmosphere, make sure that the instruments are installed in accordance with intrinsically safe or non-incendive field wiring practices.
- Verify that the operating atmosphere of the transmitter is consistent with the appropriate hazardous locations certifications.

Electrical shock could cause death or serious injury.

- Use extreme caution when making contact with the leads and terminals.

This device complies with Part 15 of the FCC Rules. Operation is subject to the following conditions: This device may not cause harmful interference. This device must accept any interference received, including interference that may cause undesired operation.

This device must be installed to ensure a minimum antenna separation distance of 20 cm from all persons.

5.2 Startup sequence

Because the Emerson™ Wireless 775 THUM™ Adapter is a power scavenging device, different capabilities are available at different times after startup. Configuration is available immediately after startup and includes Update Rate and Discovery method. All network settings including Network ID, Join Key can not be set until the radio is completely initialized. This may take up to three minutes after startup.

After this amount of time has passed, the THUM adapter will start to join the network. Time to join the network depends on network size and number of devices and if active advertising is turned on in the Gateway. After sufficient time to join has passed go to the *Explorer* page on the Emerson Wireless Gateway to see if the THUM Adapter has joined.

5.3 Advanced setup

5.3.1 Configure advanced update rate

Fast Keys	2, 2, 1,3
------------------	-----------

The “Configure Update Rate” method sets all three update rates based on one user input. The “configure Advanced Update Rate” method allows for each update rate to be set independently of the other two. Values for all update rates are between eight seconds and 60 minutes. Only one update rate can be set to eight seconds.

In AMS Device Manager, select **Manual Setup** and then the **Wireless** tab.

5.3.2 4-20 mA current

Fast Keys	2, 2, 2,1
------------------	-----------

This optimizes the THUM Adapter to the available loop current.

There are two options “Variable Current Mode” and “Fixed Current Mode”. Variable current mode is the default mode and is used when the current on the loop is changing between 3.5 mA to 25 mA.

Fixed Current mode is user selectable. This mode is for when the current on the loop is fixed and will not drop below 15 mA. If the current drops below 15 mA when the THUM Adapter is in fixed current mode, there may be issues with network traffic, and the THUM Adapter may drop off of the wireless network. The HART® loop will not be affected.

In AMS Device Manager, select **Manual Setup** and then the **Wired Device** tab.

5.3.3 Voltage drop

Fast Keys	2, 2, 2,2
------------------	-----------

This optimizes the THUM Adapter to the available voltage on the loop. There are two options: Variable and Fixed. Variable is the default mode. In Variable mode the THUM drops between 2.25 V at 3.5 mA and 1.2 V at 25 mA. In Fixed mode the THUM will always drop 2.25 volts. Fixed mode is used for verifying that there is enough voltage on the loop in the loop check procedure.

In AMS Device Manager, select **Manual Setup** and then the **Wired Device** tab.

5.3.4 Discovery mode

Fast Keys	2, 2, 2,3
------------------	-----------

The discovery mode is how the THUM Adapter determines which wired device it will update for. There are 3 modes “First Device Found”, “Fixed Polling Address”, and “Fixed Mapping”. The default mode is First Device Found. In First Device Found Mode, the THUM Adapter will update for the first wired device that it finds on the wired bus. This mode is best used when there is only one device on the wired bus. If more than one wired device is found, the THUM Adapter will go into alert.

In Fixed Polling Address mode, the THUM will only update for a wired device at specific HART polling address. Any address can be entered. If no device is found at this address, the THUM Adapter will go into an alarm state.

In Fixed Mapping mode, the user selects the long tag from a list of devices that are currently on the wired bus. If the selected device goes off line, the THUM will not start updating new device, and will go into an alarm state.

In AMS Device Manager, select **Manual Setup** and then the **Wired Device** tab.

5.3.5 Configure HART polling

Fast Keys	2, 2, 2,4
------------------	-----------

The Configure HART Polling method allows the user to select which commands the THUM Adapter will update for the wired device. The user can select from pre setup information or select custom and enter the HART command that they would like to have the THUM Adapter update for the wired device.

In AMS Device Manager, select **Manual Setup** and then the **Wired Device**.

5.3.6 Configure router only mode

Fast Keys	2, 2, 5,2
------------------	-----------

This mode will set the THUM Adapter up as a router only device. The THUM Adapter will no longer look for wired devices or update for any wired device that is on the HART loop. The THUM Adapter will continue to send updates for itself and will also act as a wireless node in the wireless network.

In AMS Select **Manual Setup** and then the **Other** tab.

5.3.7 HART address

Fast Keys	2, 2, 5,3
------------------	-----------

This is the HART Polling address of the THUM adapter. This can be changed from 0 to 63. This is used when using wired HART communication to talk with the THUM. The THUM Adapter default HART polling address is 63.

In AMS Select **Manual Setup** and then the **Other** tab.

5.3.8 HART master

Fast Keys	2, 2, 5,4
------------------	-----------

Here is where the user can set the THUM Adapter to either a primary or secondary HART master. The THUM is set to primary as default, if another primary master is on the HART loop it may be necessary to change the THUM Adapter to a secondary master. This will not affect the functionality of the THUM Adapter. The number of retries can be set to between two and five.

In AMS Device Manager, select **Manual Setup** and then the **Other** tab.

Section 6 Troubleshooting

Overview	page 35
Troubleshooting Recommended Actions	page 36
Service support	page 37

6.1 Overview

Table 6-1 on page 36 provides summarized maintenance and troubleshooting suggestions for the most common operating problems.

If you suspect malfunction despite the absence of any diagnostic messages on the Field Communicator display, follow the procedures described here to verify that transmitter hardware and process connections are in good working order. Always deal with the most likely checkpoints first.

⚠ WARNING

Failure to follow these installation guidelines could result in death or serious injury.

- Only qualified personnel should perform the installation.

Explosions could result in death or serious injury.

- Before connecting a Field Communicator in an explosive atmosphere, make sure that the instruments are installed in accordance with intrinsically safe or non-incendive field wiring practices.
- Verify that the operating atmosphere of the transmitter is consistent with the appropriate hazardous locations certifications.

Electrical shock could cause death or serious injury.

- Use extreme caution when making contact with the leads and terminals.

This device complies with Part 15 of the FCC Rules. Operation is subject to the following conditions: This device may not cause harmful interference. This device must accept any interference received, including interference that may cause undesired operation.

This device must be installed to ensure a minimum antenna separation distance of 20 cm from all persons.

Table 6-1. Troubleshooting Recommended Actions

Symptom	Recommended action
Wired troubleshooting	
Wired device does not turn on when THUM Adapter is added to loop	Check the wiring and connections between Emerson™ Wireless 775 THUM™ Adapter and wired device Verify that enough voltage is being supplied to power both the THUM Adapter and wired device
Wired Device does not function properly through loop check	Determine total voltage drop of system assume 2.5 volts for THUM Adapter Verify that enough voltage is on the loop
Can not communicate with wired device or THUM Adapter	Verify that wiring is correct Verify that enough voltage is being supplied to power both THUM Adapter and wired device Verify that between 250 and 1100 Ohms resistance is present
Can not communicate with THUM Adapter	Verify that wiring is correct Verify that enough voltage is being supplied to power both THUM Adapter and wired device Verify that between 250 and 1100 Ohms resistance is present Verify that Field communicator or AMS™ Device Manager is set to poll for THUM Adapter address Power Cycle device to try again
Configuration troubleshooting	
Can not configure THUM Adapter with Field Communicator or AMS Device Manager	Make sure that the correct DD is loaded into the Field Communicator or AMS Device Manager
THUM Adapter does not communicate with wired device	Run the “Configure Discovery Mode” method to connect the THUM Adapter to wired device Check the wiring and connections between THUM Adapter and wired device Verify that between 250 and 1100 Ohms resistance is present for HART® Communications Verify that the wired device is functioning properly Power Cycle device to try again
Duplicate HART® Master Detected	Verify that two primary masters are on the loop Then set the THUM Adapter into secondary master mode Power Cycle device to try again If THUM Adapter is in secondary master mode and Field Communicator or AMS Device Manager is connected to loop this error will occur The error will disappear after the Field Communicator or AMS Device Manager is removed from the loop.
Wireless network troubleshooting	
THUM Adapter not joining network	Verify network ID and join key Wait longer (30 minute) Verify THUM Adapter is within range of at least one other device Verify network is in active network advertise Power Cycle device to try again Verify device is configured to join. Send the “Force Join” command to the device See troubleshooting section of Emerson Wireless Gateway for more information
Limited Bandwidth Error	Reduce the Update Rate on THUM Adapter and wired device Increase communication paths by adding more wireless points Check that THUM Adapter has been online for at least an hour Check that THUM Adapter is not routing through a “limited” routing node Create a new network with an additional Gateway

6.2 Service support

To expedite the return process outside of North America, contact your Emerson representative.

Within the United States, call the Emerson Process Management Response Center toll-free number 1 800 654 7768. The center, which is available 24 hours a day, will assist you with any needed information or materials.

The center will ask for product model and serial numbers, and will provide a Return Material Authorization (RMA) number. The center will also ask for the process material to which the product was last exposed.

⚠ CAUTION

Individuals who handle products exposed to a hazardous substance can avoid injury if they are informed of, and understand, the hazard. If the product being returned was exposed to a hazardous substance as defined by OSHA, a copy of the required Material Safety Data Sheet (MSDS) for each hazardous substance identified must be included with the returned goods.

Appendix A Specifications and Reference Data

Functional specifications	page 39
Physical specifications	page 39
Performance specifications	page 40
Dimensional drawings	page 41
Ordering information	page 43

A.1 Functional specifications

Input

Any 2- or 4-wire HART® powered device.

Output

IEC 62591 (*WirelessHART*®)

Humidity limits

0–100 percent relative humidity

Update rate

User selectable, eight seconds to 60 minutes

A.2 Physical specifications

Electrical connections

The Emerson™ Wireless 775 THUM™ Adapter is connected into a powered 4–20 mA loop, powering itself by scavenging power. The THUM Adapter causes a voltage drop across the loop. The drop is linear from 2.25 volts at 3.5 mA to 1.2 volts at 25 mA, but does not effect the 4–20 mA signal on the loop. Under fault conditions, the maximum voltage drop is 2.5 volts.

Power supply

Minimum load on loop 250 Ohms.

To maintain normal operating functions of the sub-device, the power in the loop must have at least a 2.5 V margin at a 250 Ohm load.

Limit power supply to 0.5 Amps maximum.

Limit power supply to 55 Vdc maximum.

Field Communicator connections

Utilize sub-device HART connections.

Materials of construction

Housing option D - Low-copper aluminum

Housing option E - 316 SST

Paint - Polyurethane

M20-Conduit Adapter - SST

M20-Conduit Adapter O-ring - Buna-n

Antenna

Poly butadine terephthalate (PBT)/Polycarbonate (PC) integrated omnidirectional antenna

Weight

THUM Adapter only AL - 0.65 lbs. (0.29 kg)

THUM Adapter only SST - 1.1 lbs. (0.5 kg)

AL THUM Adapter with AL remote kit - 3.2 lbs. (1.45 kg)

SST THUM Adapter with SST remote kit - 5.8 lbs. (2.65 kg)

AL THUM Adapter with M20 conduit adapter - 0.85 lbs. (.038 kg)

SST THUM Adapter with M20 conduit adapter - 1.3 lbs. (0.59 kg)

Enclosure ratings

Housing option code D is NEMA 4X, and IP66.

Mounting

The THUM Adapter may be attached directly to the conduit of any 2- or 4-wire HART device or mounted remotely by using the remote mount kit.

A.3 Performance specifications

ElectroMagnetic compatibility (EMC)

Meets all industrial environment requirements of EN61326 and NAMUR NE-21 when installed with shielded wiring. The sub-device must also use shielded wiring for installation. Maximum deviation <1% span during EMC disturbance⁽¹⁾.

Vibration effect

Output unaffected when tested per the requirements of IEC60770-1 field with general application or pipeline with low vibration level (10-60 Hz 0.15 mm displacement peak amplitude/60-500 Hz 2g).

When the THUM Adapter is used on wired devices that are subject to vibration levels greater than 2 g, it is recommended that the THUM Adapter be remotely mounted using the remote mount kit.

Temperature limits

Operating limit	Storage limit
-40 to 185 °F	-40 to 185 °F
-40 to 85 °C	-40 to 85 °C

Output specifications

The THUM allows Wireless communication between the HART device it is connected to and the Gateway.

1. During surge event, device may exceed maximum EMC deviation limit or reset; however, device will self recover and return to normal operation within specified start-up time.

A.4 Dimensional drawings

Figure A-1. THUM Adapter 1/2 NPT

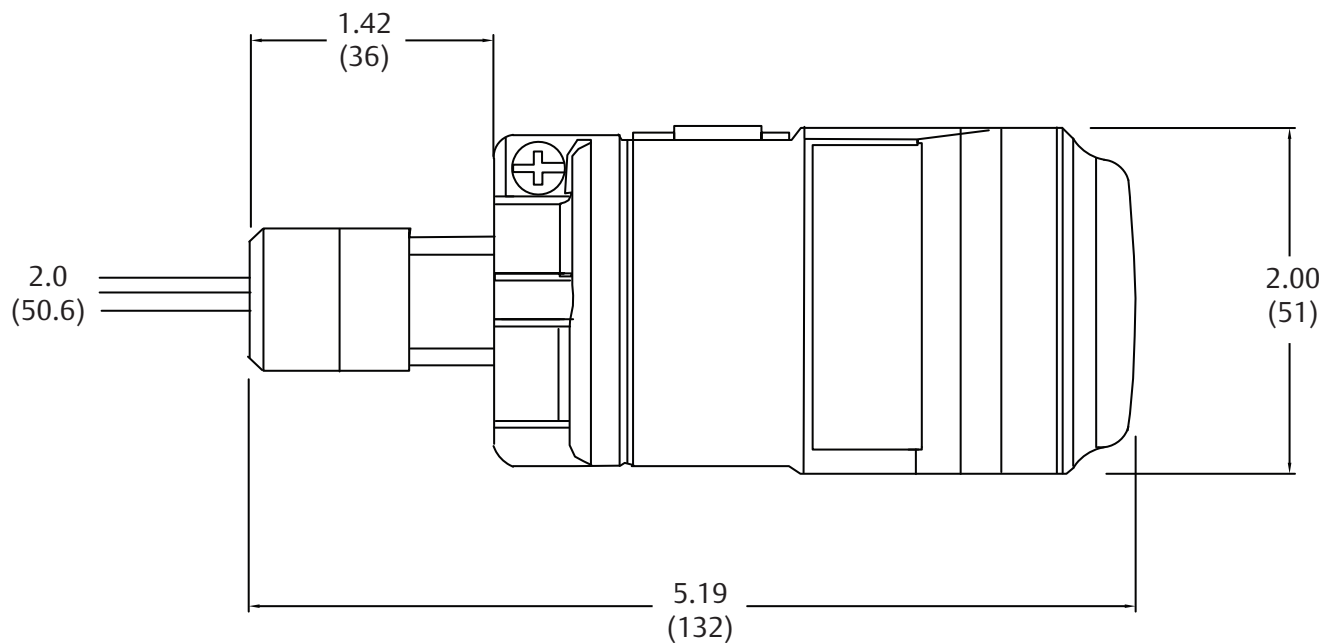

Dimensions are in inches (millimeters)

Figure A-2. THUM Adapter with M20 Conduit Adapter

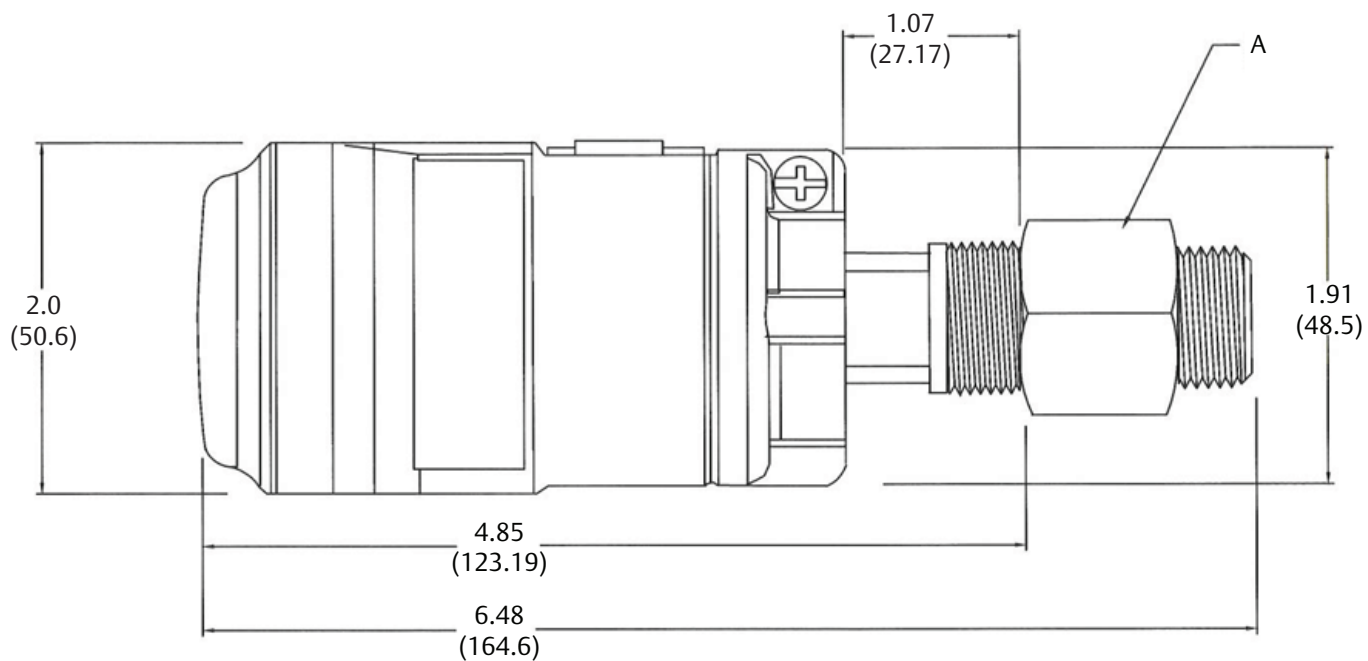

A. Adapter for M20 entry
Dimensions are in inches (millimeters).

Figure A-3. THUM Adapter with Remote Mount Kit

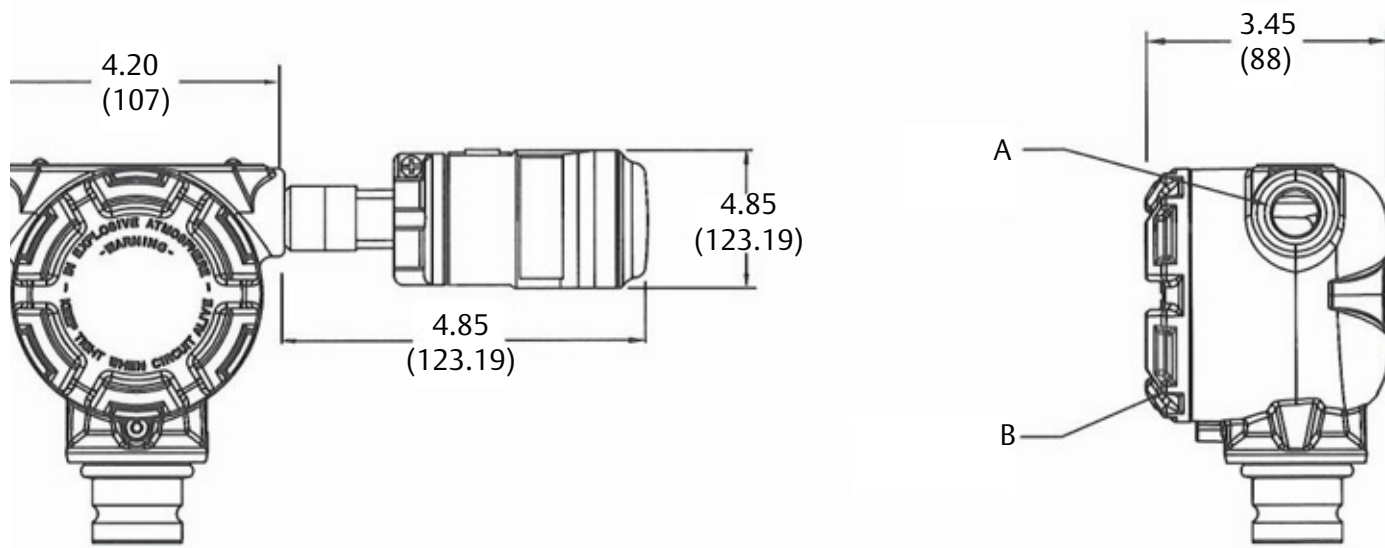

A. Conduit entry
B. Electronic side
Dimensions are in inches (millimeters).

A.5 Ordering information

Table A-1. Smart Wireless THUM Adapter ordering information

The starred offerings (★) represent the most common options and should be selected for best delivery. The non-starred offerings are subject to additional delivery lead time.

Model	Product description	
775	Smart Wireless THUM Adapter	
Output		
X	Wireless	
Housing		
D	Aluminum	★
E	SST	
Mounting connection		
1	1/2 - 14 NPT	★
2	M20-Conduit Adapter	★
PlantWeb functionality		
1	HART Data	★
Certification		
NA	No Approval	★
I5	FM Intrinsically Safe, Non-incendive	★
I6	CSA Intrinsically Safe	★
I1	ATEX Intrinsic Safety	★
N1	ATEX Type n	★
I7	IECEX Intrinsic Safety	★
N7	IECEX Type n	★
I2	INMETRO Intrinsic Safety	★
N2	INMETRO Type n	★
I3	China Intrinsic Safety	★
IP	Korea (KOSHA) Intrinsic Safety	★
IW	India (CCOE) Intrinsic Safety	★
IM	GOST (Russia) Intrinsically Safe	★
Wireless update rate, operating frequency, and protocol		
WA3	User Configurable Update Rate, 2.4 GHz DSSS, WirelessHART	★
Omnidirectional, wireless antenna, and SmartPower™ options		
WK9	Long range, Integral Antenna, Power Scavenging	★
Typical model number: 775XD11I5WA3WK9		

A.6 Accessories and spare parts

Table A-2. Accessories

Item description	Part number
Remote Mount Kit - AI	00775-9000-0001
Remote Mount Kit - SST	00775-9000-0011
M20-Conduit Adapter	00775-9001-0001

Appendix B Product Certifications

Rev 2.2

European Directive Information	page 45
Ordinary Location Certification from FM Approvals	page 45
Telecommunication compliance (for wireless products only)	page 45
FCC and IC (for wireless products only)	page 45
Installing Equipment in North America	page 45

B.1 European Directive Information

A copy of the EC Declaration of Conformity can be found at the end of the Quick Start Guide. The most recent revision of the EC Declaration of Conformity can be found at Emerson.com/Rosemount.

B.2 Ordinary Location Certification from FM Approvals

As standard, the transmitter has been examined and tested to determine that the design meets the basic electrical, mechanical, and fire protection requirements by FM Approvals, a nationally recognized test laboratory (NRTL) as accredited by the Federal Occupational Safety and Health Administration (OSHA).

B.3 Telecommunication compliance (for wireless products only)

All wireless devices require certification to ensure that they adhere to regulations regarding the use of the RF spectrum. Nearly every country requires this type of product certification. Emerson is working with governmental agencies around the world to supply fully compliant products and remove the risk of violating country directives or laws governing wireless device usage.

B.4 FCC and IC (for wireless products only)

This device complies with Part 15 of the FCC Rules. Operation is subject to the following conditions: This device may not cause harmful interference. This device must accept any interference received, including interference that may cause undesired operation. This device must be installed to ensure a minimum antenna separation distance of 20 cm from all persons.

B.5 Installing Equipment in North America

The US National Electrical Code (NEC) and the Canadian Electrical Code (CEC) permit the use of Division marked equipment in Zones and Zone marked equipment in Divisions. The markings must be suitable for the area classification, gas, and temperature class. This information is clearly defined in the respective codes.

B.6 USA

- E5** USA Explosionproof
Certificate: CSA 2174201
Standards: FM Class 3600 - 2011, FM Class 3615 - 2006, ANSI/UL 61010-1 3rd Edition
Markings: Class I, Division 1, Groups A, B, C and D; T5, T6; Type 4X and IP66 ($-50^{\circ}\text{C} \leq T_a \leq +70^{\circ}\text{C}$)

- I5** USA Intrinsically Safe (IS) and Non-incendive
Certificate: 3036224
Standards: FM Class 3600 - 1998, FM Class 3610 - 2007, FM Class 3611 - 2004, FM Class 3810 - 2005, NEMA 250 - 2003, IEC 60529 - 2004
Markings: IS CL I, DIV 1, GP A, B, C, D; CL II, DIV 1, GP E, F, G; Class III; Class 1, Zone 0, AEx ia IIC T4; NI CL I, DIV 2, GP A, B, C, D T4; T4(-50°C ≤ T_a ≤ +70°C) when connected per Rosemount drawing 00775-0010; Type 4X/IP66

B.7 Canada

- E6** Canada Explosionproof
Certificate: CSA 2174201
Standards: CAN/CSA C22.2 No. 0-M91, CSA Std. C22.2 No. 30-M1986, CAN/CSA-C22.2 No. 94-M91, CAN/CSA-C22.2 No. 61010-1-12, CSA Std. C22.2 No. 60529
Markings: Class I, Division 1, Groups A, b, C and D; T5, T6; Type 4X and IP66 (-50 °C ≤ T_a ≤ +70 °C)
- I6** Canada Intrinsically Safe
Certificate: 2174201
Standards: CAN/CSA C22.2 No. 0-M91 (R2001), CAN/CSA C22.2 No. 94-M91 (R2001), CSA Std C22.2 No. 142-M1987, CAN/CSA C22.2 No.157-92, CSA Std C22.2 No. 213-M1987, C22.2 No. 60529
Markings: Intrinsically Safe Class I, Division 1, Groups A, B, C, D T3C; Suitable for use in Class I, Division 2, Groups A, B, C, D T3C; T3C (-50 °C ≤ T_a ≤ +70 °C) when installed per Rosemount drawing 00775-0012; Type 4X/IP66

B.8 Europe

- I1** ATEX Intrinsic Safety
Certificate: Baseefa09ATEX0125X
Standards: IEC 60079-0:2011; EN60079-11:2012;
Markings: Ⓔ II 1G Ex ia IIC T4 Ga, T4(-50 °C ≤ T_a ≤ +70 °C)

Special Conditions for Safe Use (X):

1. The surface resistivity of the antenna cover is greater than 1 GΩ. TO avoid electrostatic charge build-up, it must not be rubbed or cleaned with solvents or a dry cloth.
2. The Emerson™ Wireless 775 THUM Adapter enclosure may be made of aluminum alloy and given a protective polyurethane paint finish; however, care should be taken to protect it from impact or abrasion if located in zone 0.

- N1** ATEX Type n
Certificate: Baseefa09ATEX0131
Standards: IEC 60079-0:2011, EN 60079-15:2010;
Markings: Ⓔ II 3G nA IIC T4 Gc, T4(-50 °C ≤ T_a ≤ +70 °C) IP66

B.9 International

- I7** IECEx Intrinsic Safety
Certificate: IECEx BAS 09.0050X
Standards: IEC 60079-0:2011, IEC 60079-11:2011
Markings: Ex ia IIC T4 Ga, T4(-50 °C ≤ T_a ≤ +70 °C) IP66

Special Conditions for Safe Use (X):

1. The surface resistivity of the antenna is greater than 1 GΩ. To avoid electrostatic charge build-up, it must not be rubbed or cleaned with solvents or a dry cloth.
2. The Emerson 775 enclosure may be made of aluminum alloy and given a protective polyurethane paint finish; however, care should be taken to protect it from impact or abrasion if located in zone 0.

- N7** IECEx Type n
Certificate: IECEx BAS 09.0058
Standards: IEC 60079-0:2011, IEC 60079-15:2010;
Markings: Ex nA IIC T4 Gc, T4(-50 °C ≤ T_a ≤ +70 °C) IP66

B.10 Brazil

- I2** INMETRO Intrinsic Safety
Certificate: UL-BR 15.0089X
Standards: ABNT NBR IEC 60079-0:2008, ABNT NBR IEC 60079-11:2009
Markings: Ex ia IIC T4 Ga (-50 °C ≤ T_a ≤ +70 °C) IP66

Special Conditions for Safe Use (X):

1. The surface resistivity of the antenna is greater than 1 GΩ. To avoid electrostatic charge build-up, it must not be rubbed or cleaned with solvents or a dry cloth.
2. The enclosure may be made of aluminum alloy and given a protective polyurethane paint finish; special care must be taken to minimize the risk of impact or friction of the housing which can cause the generation of sparks.

N2 INMETRO Type n
 Certificate: UL-BR 15.0027
 Standards: ABNT NBR IEC 60079-0:2008, IEC 60079-15:2010;
 Markings: Ex nA IIC T4 Gc (-50 °C ≤ T_a ≤ +70 °C) IP66

B.11 China

I3 NEPSI Intrinsic Safety
 Certificate: GYJ14.1094X
 Standards: GB3836.1 - 2010, GB3836.4 - 2010, GB3836.20-2010
 Markings: Ex ia IIC T4 Ga, -50 ~ +70 °C

Special Condition for Safe Use (X):

1. See certificate for special conditions.

B.12 Japan

I4 TIIS Intrinsic Safety
 Certificate: TC22150X
 Markings: Ex ia IIB T4 Ga, -50 °C ~ +70 °C

Special Condition for Safe Use (X):

1. See certificate for special conditions.

B.13 EAC - Belarus, Kazakhstan, Russia

IM Technical Regulation Customs Union (EAC) Intrinsic Safety
 Certificate: TC RU C-US.AA87.B.00228
 Markings: 0Ex ia IIC T4 Ga X T4 (-50°C ≤ T_a ≤ +70 °C) IP66

Special Condition for Safe Use (X):

1. See certificate for special conditions.

NM Technical Regulation Customs Union (EAC) Type n
 Certificate: TC RU C-US.AA87.B.00228
 Markings: 2Ex nA IIC T4 Gc X T4 (-50 °C ≤ T_a ≤ +70 °C) IP66

Special Condition for Safe Use (X):

1. See certificate for special conditions.

B.14 Republic of Korea

IP Korea (KOSHA) Intrinsic Safety
 Certificate: 10-KB4BO-0010X
 Markings: Ex ia IIC T4

Special Conditions for Safe Use (X):

1. See certificate for special conditions.

B.15 India

IW India (CCOE) Intrinsic Safety
 Certificate: A/P/HQ/MH/104/2023(P242867)
 Markings: Ex ia IIC T4

B.16 Combinations

KM Combination of IM and NM

Figure B-1. THUM Adapter FM I.S. & Class 1, Div. 2 Installation Drawing (1 of 2)

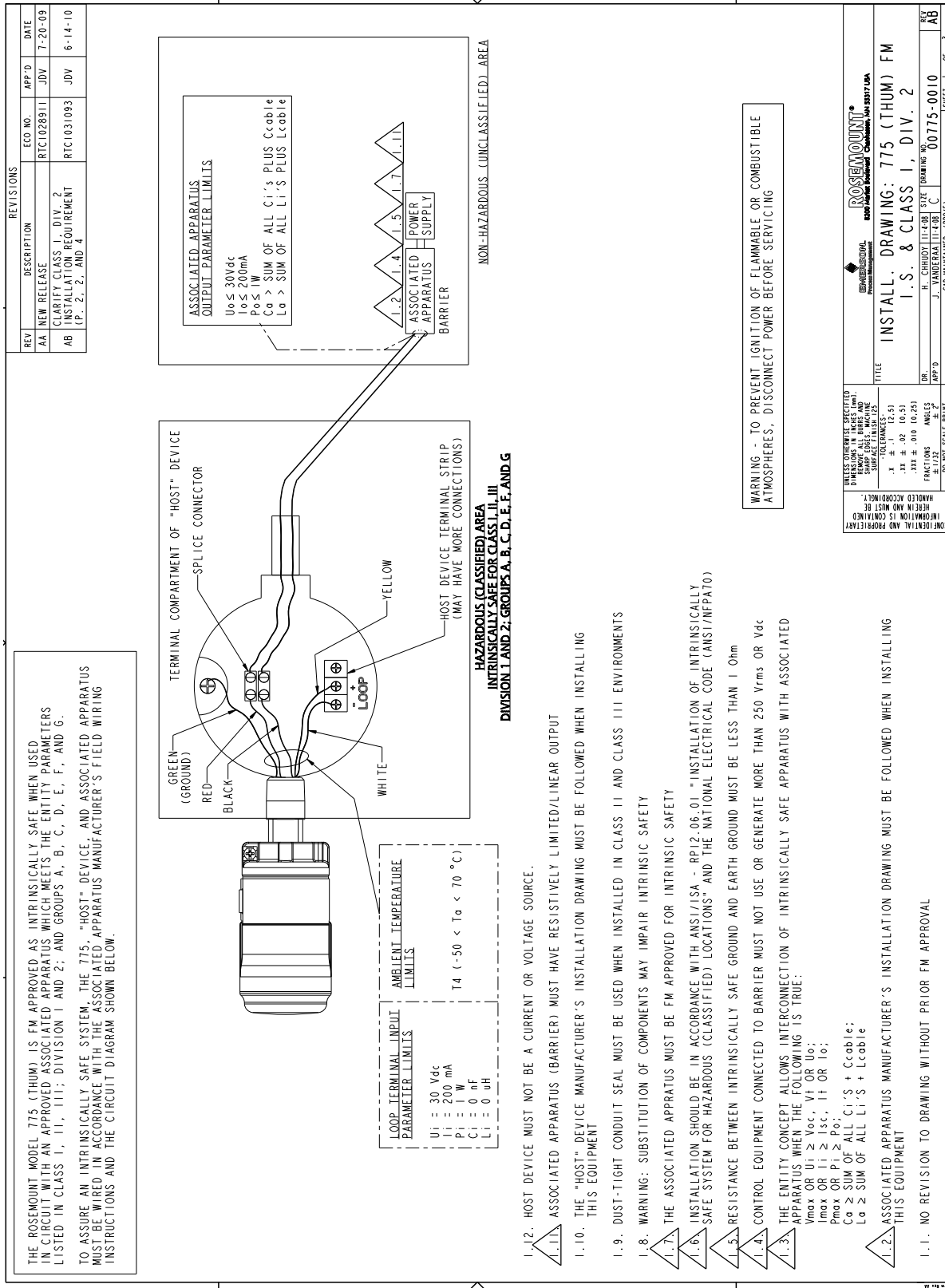

Figure B-3. THUM Adapter CSA I.S. Installation drawing

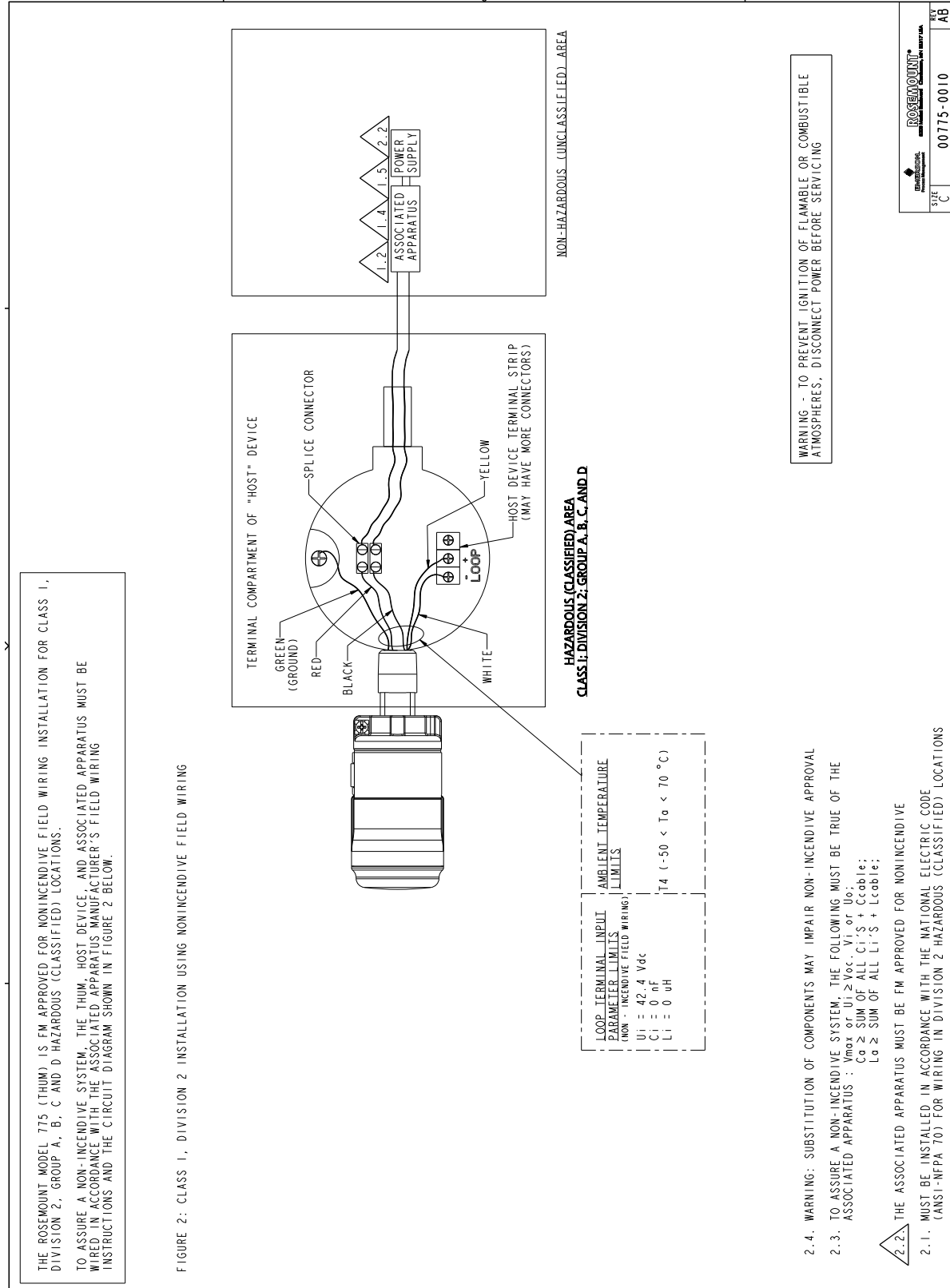
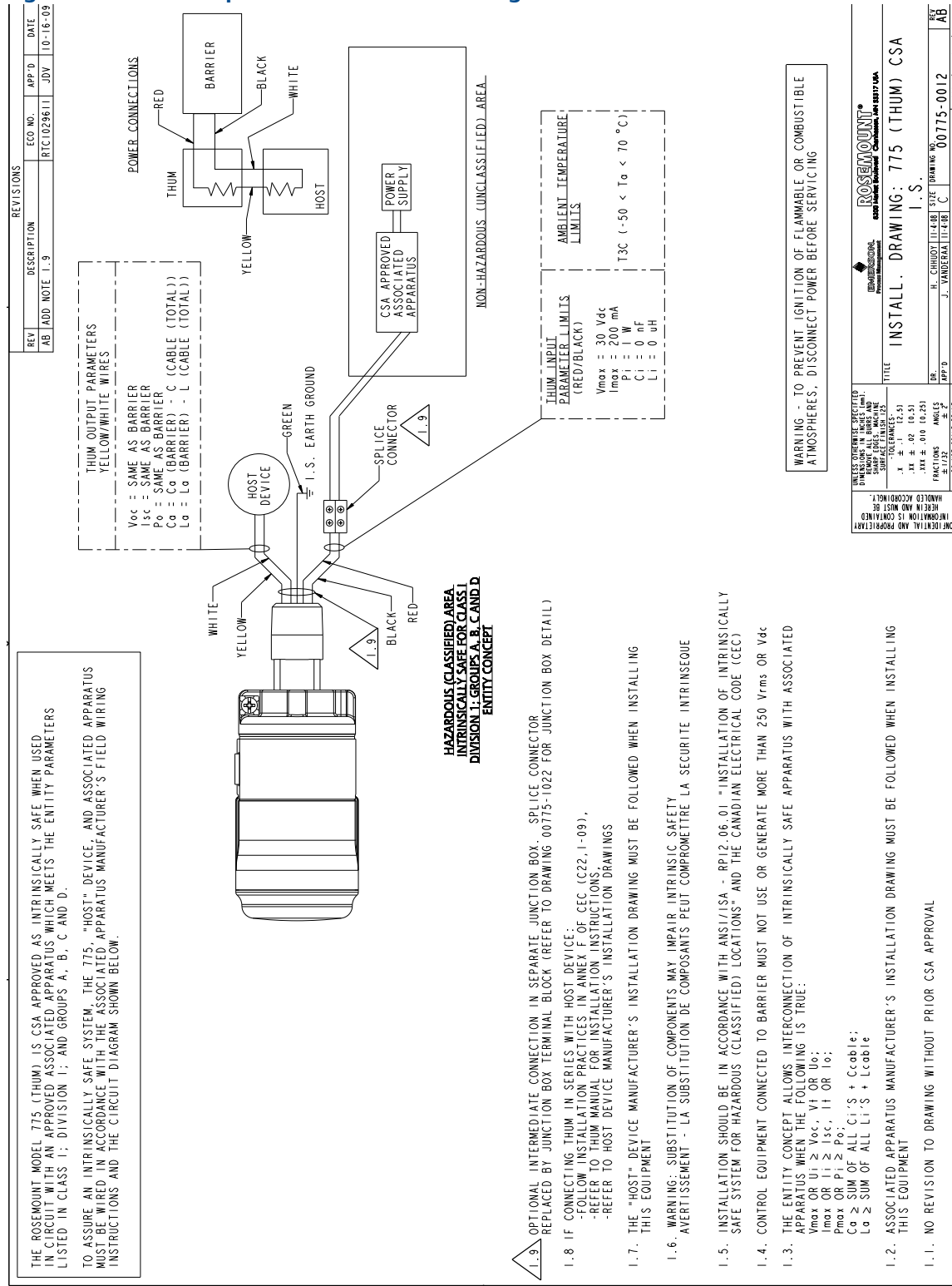

Figure B-4. THUM Adapter CSA Installation Drawing



Global Headquarters

Emerson Automation Solutions

6021 Innovation Blvd.
Shakopee, MN 55379, USA
+1 800 999 9307 or +1 952 906 8888
+1 952 949 7001
RFQ.RMD-RCC@Emerson.com

North America Regional Office

Emerson Automation Solutions

8200 Market Blvd.
Chanhassen, MN 55317, USA
+1 800 999 9307 or +1 952 906 8888
+1 952 949 7001
RMT-NA.RCCRFQ@Emerson.com

Latin America Regional Office

Emerson Automation Solutions

1300 Concord Terrace, Suite 400
Sunrise, FL 33323, USA
+1 954 846 5030
+1 954 846 5121
RFQ.RMD-RCC@Emerson.com

Europe Regional Office

Emerson Automation Solutions Europe GmbH

Neuhofstrasse 19a P.O. Box 1046
CH 6340 Baar
Switzerland
+41 (0) 41 768 6111
+41 (0) 41 768 6300
RFQ.RMD-RCC@Emerson.com

Asia Pacific Regional Office

Emerson Automation Solutions Asia Pacific Pte Ltd

1 Pandan Crescent
Singapore 128461
+65 6777 8211
+65 6777 0947
Enquiries@AP.Emerson.com

Middle East and Africa Regional Office

Emerson Automation Solutions

Emerson FZE P.O. Box 17033
Jebel Ali Free Zone - South 2
Dubai, United Arab Emirates
+971 4 8118100
+971 4 8865465
RFQ.RMTMEA@Emerson.com



[Linkedin.com/company/Emerson-Automation-Solutions](https://www.linkedin.com/company/Emerson-Automation-Solutions)



[Twitter.com/Rosemount_News](https://twitter.com/Rosemount_News)



[Facebook.com/Rosemount](https://www.facebook.com/Rosemount)



[Youtube.com/user/RosemountMeasurement](https://www.youtube.com/user/RosemountMeasurement)



[Google.com/+RosemountMeasurement](https://www.google.com/+RosemountMeasurement)

Standard Terms and Conditions of Sale can be found on the [Terms and Conditions of Sale page](#).

The Emerson logo is a trademark and service mark of Emerson Electric Co. THUM Adapter, Plantweb, SmartPower, Rosemount, and the Rosemount logotype are trademarks of Emerson.

HART and WirelessHART are registered trademark of the FieldComm Group.

All other marks are the property of their respective owners.

© 2017 Emerson. All rights reserved.