

# 7526A

Precision Process Calibrator

Users Manual

## **LIMITED WARRANTY AND LIMITATION OF LIABILITY**

Each Fluke product is warranted to be free from defects in material and workmanship under normal use and service. The warranty period is one year and begins on the date of shipment. Parts, product repairs, and services are warranted for 90 days. This warranty extends only to the original buyer or end-user customer of a Fluke authorized reseller, and does not apply to fuses, disposable batteries, or to any product which, in Fluke's opinion, has been misused, altered, neglected, contaminated, or damaged by accident or abnormal conditions of operation or handling. Fluke warrants that software will operate substantially in accordance with its functional specifications for 90 days and that it has been properly recorded on non-defective media. Fluke does not warrant that software will be error free or operate without interruption.

Fluke authorized resellers shall extend this warranty on new and unused products to end-user customers only but have no authority to extend a greater or different warranty on behalf of Fluke. Warranty support is available only if product is purchased through a Fluke authorized sales outlet or Buyer has paid the applicable international price. Fluke reserves the right to invoice Buyer for importation costs of repair/replacement parts when product purchased in one country is submitted for repair in another country.

Fluke's warranty obligation is limited, at Fluke's option, to refund of the purchase price, free of charge repair, or replacement of a defective product which is returned to a Fluke authorized service center within the warranty period.

To obtain warranty service, contact your nearest Fluke authorized service center to obtain return authorization information, then send the product to that service center, with a description of the difficulty, postage and insurance prepaid (FOB Destination). Fluke assumes no risk for damage in transit. Following warranty repair, the product will be returned to Buyer, transportation prepaid (FOB Destination). If Fluke determines that failure was caused by neglect, misuse, contamination, alteration, accident, or abnormal condition of operation or handling, including overvoltage failures caused by use outside the product's specified rating, or normal wear and tear of mechanical components, Fluke will provide an estimate of repair costs and obtain authorization before commencing the work. Following repair, the product will be returned to the Buyer transportation prepaid and the Buyer will be billed for the repair and return transportation charges (FOB Shipping Point).

**THIS WARRANTY IS BUYER'S SOLE AND EXCLUSIVE REMEDY AND IS IN LIEU OF ALL OTHER WARRANTIES, EXPRESS OR IMPLIED, INCLUDING BUT NOT LIMITED TO ANY IMPLIED WARRANTY OF MERCHANTABILITY OR FITNESS FOR A PARTICULAR PURPOSE. FLUKE SHALL NOT BE LIABLE FOR ANY SPECIAL, INDIRECT, INCIDENTAL, OR CONSEQUENTIAL DAMAGES OR LOSSES, INCLUDING LOSS OF DATA, ARISING FROM ANY CAUSE OR THEORY.**

Since some countries or states do not allow limitation of the term of an implied warranty, or exclusion or limitation of incidental or consequential damages, the limitations and exclusions of this warranty may not apply to every buyer. If any provision of this Warranty is held invalid or unenforceable by a court or other decision-maker of competent jurisdiction, such holding will not affect the validity or enforceability of any other provision.

Fluke Corporation  
P.O. Box 9090  
Everett, WA 98206-9090  
U.S.A.

Fluke Europe B.V.  
P.O. Box 1186  
5602 BD Eindhoven  
The Netherlands

# Table of Contents

Chapter	Title	Page
<b>1</b>	<b>Introduction .....</b>	<b>1-1</b>
	Introduction.....	1-3
	Contact Fluke Calibration.....	1-3
	Safety Information.....	1-4
	Unpack the Product.....	1-5
	Standard Equipment.....	1-6
	Options and Accessories.....	1-6
	Product Description.....	1-7
	Front-Panel Overview.....	1-7
	Primary Input/Output Terminals.....	1-8
	Primary Input/Output Display and Controls.....	1-9
	Isolated Input Display, Controls, and Terminals.....	1-12
	Rear Panel.....	1-13
	Display Layouts.....	1-14
	Error Messages.....	1-17
	Set Up.....	1-17
	Specifications.....	1-18
	General Specifications.....	1-18
	DC Voltage Specifications, Output.....	1-19
	DC Voltage Specifications, Isolated Input.....	1-19
	DC Current Specifications, Output.....	1-19
	DC Current Specifications, Isolated Input.....	1-19
	Resistance Specifications, Output.....	1-20
	Resistance Specifications, Input.....	1-20
	Thermocouple Specification, Output and Input.....	1-21
	RTD and Thermistor Specification, Output.....	1-22
	RTD and Thermistor Specification, Input.....	1-23
	Pressure Measurement Specifications.....	1-24
	Switch Test Specifications, Isolated Input.....	1-24
<b>2</b>	<b>Primary Inputs and Outputs .....</b>	<b>2-1</b>
	Introduction.....	2-3
	DC Voltage Output.....	2-3
	DC Current Output.....	2-4

	Resistance Temperature Detector (RTD) and Ohms Measure.....	2-5
	Resistance Temperature Detector (RTD) and Ohms Source .....	2-6
	Resistance Temperature Detector (RTD) with Custom Coefficients.....	2-7
	Standard Platinum Resistance Thermometer (SPRT) Coefficients .....	2-8
	Thermocouple (TC) Measure.....	2-9
	Thermocouple (TC) Source .....	2-11
	Pressure Measure .....	2-12
<b>3</b>	<b>Isolated Inputs .....</b>	<b>3-1</b>
	Voltage Input .....	3-3
	Current Input.....	3-3
	Pressure Input .....	3-4
	Switch Test .....	3-5
	Output Setpoints .....	3-6
<b>4</b>	<b>Application Notes .....</b>	<b>4-1</b>
	Introduction.....	4-3
	P/I Transmitter .....	4-3
	I/P Transmitter .....	4-4
	V/I Transmitter .....	4-5
	RTD Test.....	4-6
	RTD Transmitter.....	4-7
	Thermocouple Test .....	4-8
	Thermocouple Transmitter.....	4-9
	RTD Indicator.....	4-10
	Precision Current Trip .....	4-11
	I/I Isolator/Transmitter .....	4-12
	Precision Temperature Measurement with Probe.....	4-13
	Temperature Switch Test.....	4-14
	Pressure Switch Test.....	4-16
<b>5</b>	<b>LCD and Remote Interface Setup Procedures.....</b>	<b>5-1</b>
	Introduction.....	5-3
	Access LCD and Remote Interface Setup Procedures .....	5-3
	Remote Interface.....	5-3
	Set Up the RS-232 Port for Remote Control .....	5-4
	Use with Computer USB Ports.....	5-5
	Set Up the IEEE-488 Port for Remote Control .....	5-5
	Change Between Local and Remote Operation.....	5-6
	IEEE-488 Interface Overview.....	5-7
	Command Use.....	5-8
	Command Syntax .....	5-10
	Check Product Status.....	5-13
<b>6</b>	<b>Remote Commands.....</b>	<b>6-1</b>
	Introduction.....	6-3
	Command Summary by Function .....	6-3
	Error Code List .....	6-6
	Remote Command List .....	6-7

<b>7</b>	<b>Maintenance.....</b>	<b>7-1</b>
	Introduction.....	7-3
	Clean the Calibrator.....	7-3
	Replace a Line Fuse.....	7-3
	Change the Line Voltage .....	7-3



# List of Tables

Table	Title	Page
1-1.	Symbols.....	1-5
1-2.	Error Messages.....	1-17
1-3.	Line-Voltage Settings.....	1-17
2-1.	Default Custom RTD Coefficients.....	2-8
2-2.	Other Common RTD Coefficients.....	2-8
2-3.	Fluke 700 Series Pressure Modules.....	2-13
2-4.	Fluke 525A-P Series Pressure Modules.....	2-14
5-1.	Operating State Transitions.....	5-7
5-2.	RS-232 Emulation of IEEE-488 Messages.....	5-7
5-3.	Commands for RS-232 Only.....	5-10
5-4.	Units Accepted in Parameters and Used in Responses.....	5-11
5-5.	Terminator Characters.....	5-12
5-6.	Status Register Summary.....	5-13
5-7.	Serial Poll Status Byte (STB) and Service Request Enable (SRE) Registers.....	5-14
5-8.	Event Status Register (ESR) and Event Status Enable (ESE) Registers.....	5-15
6-1.	Common Commands.....	6-3
6-2.	External Connection Commands.....	6-4
6-3.	Output Commands.....	6-4
6-4.	Measurement Commands.....	6-5
6-5.	RS-232 Operation Mode Commands.....	6-5
6-6.	Status Commands.....	6-5
6-7.	Error Code List.....	6-6
7-1.	Replacement Fuses.....	7-3





# List of Figures

Figure	Title	Page
1-1.	Front Panel .....	1-7
1-2.	Primary Input/Output Terminals .....	1-8
1-3.	Primary Input/Output Display and Controls .....	1-9
1-4.	Isolated Input Display, Controls, and Terminals.....	1-12
1-5.	Rear Panel .....	1-13
1-6.	Primary Voltage and Current Display .....	1-14
1-7.	Primary Thermocouple and RTD Display .....	1-15
1-8.	Primary and Isolated Pressure Display.....	1-16
1-9.	Isolated Voltage and Current Display .....	1-16
2-1.	DC Voltage Output Connections.....	2-3
2-2.	DC Current Output Connection.....	2-4
2-3.	RTD/ $\Omega$ Input Connection .....	2-5
2-4.	RTD/ $\Omega$ Output Connection .....	2-6
2-5.	Thermocouple Input Connection.....	2-10
2-6.	Thermocouple Output Connection .....	2-11
2-7.	Pressure Module Connection .....	2-12
3-1.	Isolated DC Voltage Input Connection .....	3-3
3-2.	Isolated DC Current Input Connection.....	3-3
3-3.	Isolated Pressure Module Connection.....	3-4
3-4.	Swich Test and Pressure Module Connections .....	3-5
4-1.	P/I Transmitter Application.....	4-3
4-2.	I/P Transmitter Application.....	4-4
4-3.	V/I Transmitter Application .....	4-5
4-4.	RTD Test Application .....	4-6
4-5.	RTD Transmitter Application .....	4-7
4-6.	Thermocouple Test Application.....	4-8
4-7.	Thermocouple Transmitter Application .....	4-9
4-8.	RTD Indicator Application.....	4-10
4-9.	Precision Current Trip Application .....	4-11
4-10.	I/I Isolator/Transmitter Application .....	4-12
4-11.	Precision Temperature Measurement with Probe .....	4-13
4-12.	Temperature Switch Test Connections .....	4-14
4-13.	Pressure Switch Test Connections .....	4-16
5-1.	RS-232 Remote Connection.....	5-4
5-2.	RS-232 Remote Connection.....	5-5

5-3.	IEEE-488 (GPIB) Remote Connection .....	5-6
5-4.	Status Register Overview .....	5-13

# Chapter 1

## Introduction

Title	Page
Introduction.....	1-3
Contact Fluke Calibration .....	1-3
Safety Information .....	1-4
Unpack the Product.....	1-5
Standard Equipment.....	1-6
Options and Accessories .....	1-6
Product Description .....	1-7
Front-Panel Overview .....	1-7
Primary Input/Output Terminals .....	1-8
Primary Input/Output Display and Controls.....	1-9
Isolated Input Display, Controls, and Terminals.....	1-12
Rear Panel.....	1-13
Display Layouts.....	1-14
Error Messages .....	1-17
Set Up .....	1-17
Specifications.....	1-18
General Specifications .....	1-18
DC Voltage Specifications, Output .....	1-19
DC Voltage Specifications, Isolated Input .....	1-19
DC Current Specifications, Output.....	1-19
DC Current Specifications, Isolated Input.....	1-19
Resistance Specifications, Output .....	1-20
Resistance Specifications, Input.....	1-20
Thermocouple Specification, Output and Input .....	1-21
RTD and Thermistor Specification, Output .....	1-22
RTD and Thermistor Specification, Input .....	1-23
Pressure Measurement Specifications .....	1-24
Switch Test Specifications, Isolated Input .....	1-24



## **Introduction**

The Fluke 7526A Precision Process Calibrator (the “Product” or “Calibrator”) is an accurate, full-featured temperature, pressure, and DC calibrator. The Calibrator is meant for research and development, manufacturing, and calibration lab procedures. The Product operation is easy and you will quickly understand its operations and features.

Some time-saving features let you:

- Save, recall, and automatically move through setpoints for each output range
- Record user-defined RTD curves
- Remotely interface with the Product

## **Contact Fluke Calibration**

To contact Fluke Calibration, call one of the subsequent telephone numbers:

- Technical Support USA: 1-877-355-3225
- Calibration/Repair USA: 1-877-355-3225
- Canada: 1-800-36-FLUKE (1-800-363-5853)
- Europe: +31-40-2675-200
- Japan: +81-3-6714-3114
- Singapore: +65-6799-5566
- China: +86-400-810-3435
- Brazil: +55-11-3759-7600
- Anywhere in the world: +1-425-446-6110

To see product information and download the latest manual supplements, visit Fluke Calibration’s website at [www.flukecal.com](http://www.flukecal.com).

To register your product, visit <http://flukecal.com/register-product>.

## Safety Information

A **Warning** identifies conditions and procedures that are dangerous to the user; A **Caution** identifies conditions and procedures that could cause Product damage, equipment under test damage, or permanent loss of data.













### Warnings

To prevent possible electrical shock, fire, or personal injury:

- Read all safety Information before you use the Product.
- Carefully read all instructions.
- Use the Product only as specified, or the protection supplied by the Product can be compromised.
- Use this Product indoors only.
- Examine the case before you use the Product. Look for cracks or missing plastic. Carefully look at the insulation around the terminals.
- Use only the mains power cord and connector approved for the voltage and plug configuration in your country and rated for the Product.
- Replace the mains power cord if the insulation is damaged or if the insulation shows signs of wear.
- Make sure the ground conductor in the mains power cord is connected to a protective earth ground. Disruption of the protective earth could put voltage on the chassis that could cause death.
- Do not put the Product where access to the mains power cord is blocked.
- Do not touch voltages > 30 V ac rms, 42 V ac peak, or 60 V dc.
- Use only cables with correct voltage ratings.
- Do not apply more than the rated voltage, between the terminals or between each terminal and earth ground.
- Do not use the Product around explosive gas, vapor, or in damp or wet environments.
- Remove all probes, test leads, and accessories that are not necessary for the measurement.
- Do not use the Product if it operates incorrectly.
- Do not use and disable the Product if it is damaged.

Table 1-1 shows the symbols used on the Product and in this manual.

**Table 1-1. Symbols**

Symbol	Definition	Symbol	Definition
	Risk of Danger. Important information. See Manual.		This product complies with the WEEE Directive (2002/96/EC) marking requirements. The affixed label indicates that you must not discard this electrical/electronic product in domestic household waste. Product Category: With reference to the equipment types in the WEEE Directive Annex I, this product is classed as category 9 "Monitoring and Control Instrumentation" product. Do not dispose of this product as unsorted municipal waste. Go to Fluke's website for recycling information.
	Hazardous voltage. Risk of electric shock.		Fuse
	AC (Alternating Current)		Protective Earth Ground
	Earth ground		Conforms to European Union directives.
	AC (Alternating Current) and DC (Direct Current)		DC (Direct Current)
	This product has been tested to the requirements of CAN/CSA-C22.2 No. 61010-1, third edition.		Pressure

## Unpack the Product

When you receive the Product, examine the container and equipment for signs of damage. Note indications of damage while in transit. Immediately report damage to the shipping agent.

*Note*

*The carrier will not honor claims unless all shipment material is kept for their inspection.*

After you examine and remove the contents, keep the package material and carton in the case that shipment is necessary.

Remove the Package List and make sure that all of the shown equipment is received. If there are questions about the shipment, contact Fluke. See the "Contact Fluke Calibration" section.

## ***Standard Equipment***

Make sure the basic Calibrator package is complete. It includes:

- The Calibrator
- Users Manual CD-ROM
- Getting Started
- AC Mains Cord
- Thermocouple Shorting Jumper
- NIST Traceable Calibration Report
- USB to Serial Adapter Cable.

## ***Options and Accessories***

For more information about these accessories and their prices, contact your Fluke representative.

- 5520A-525A Leads kit
- Y7526A Rack Mount kit
- Fluke 700 and 525A-P series pressure modules
- MET/CAL with 7526A Function Select Code (FSC)
- MET/CAL 7526A calibration procedure



## Product Description

This section is a general description of the Product.

### Front-Panel Overview

Figure 1-1 shows the layout of the front panel. Each of the three primary divisions is given in the subsequent sections.

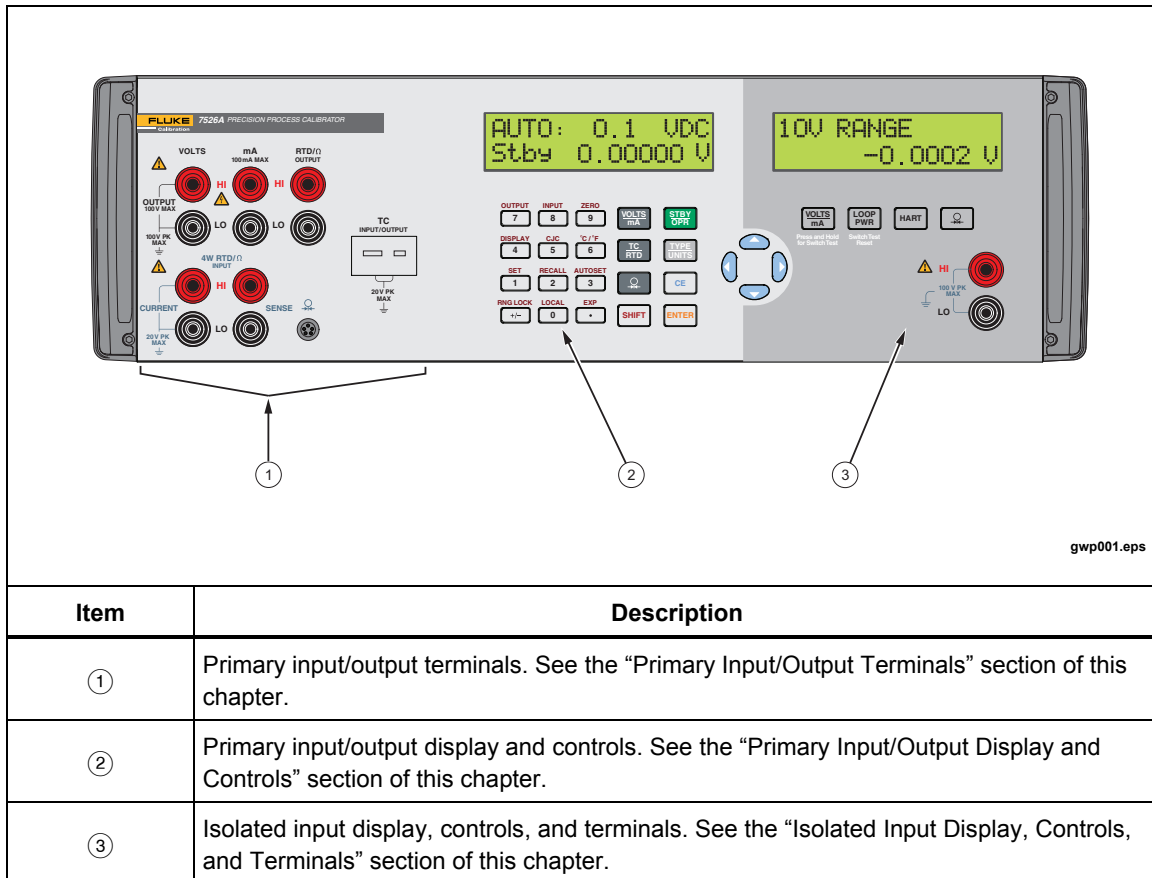

Item	Description
①	Primary input/output terminals. See the “Primary Input/Output Terminals” section of this chapter.
②	Primary input/output display and controls. See the “Primary Input/Output Display and Controls” section of this chapter.
③	Isolated input display, controls, and terminals. See the “Isolated Input Display, Controls, and Terminals” section of this chapter.

Figure 1-1. Front Panel

## Primary Input/Output Terminals

Figure 1-2 shows the primary input/output terminals.

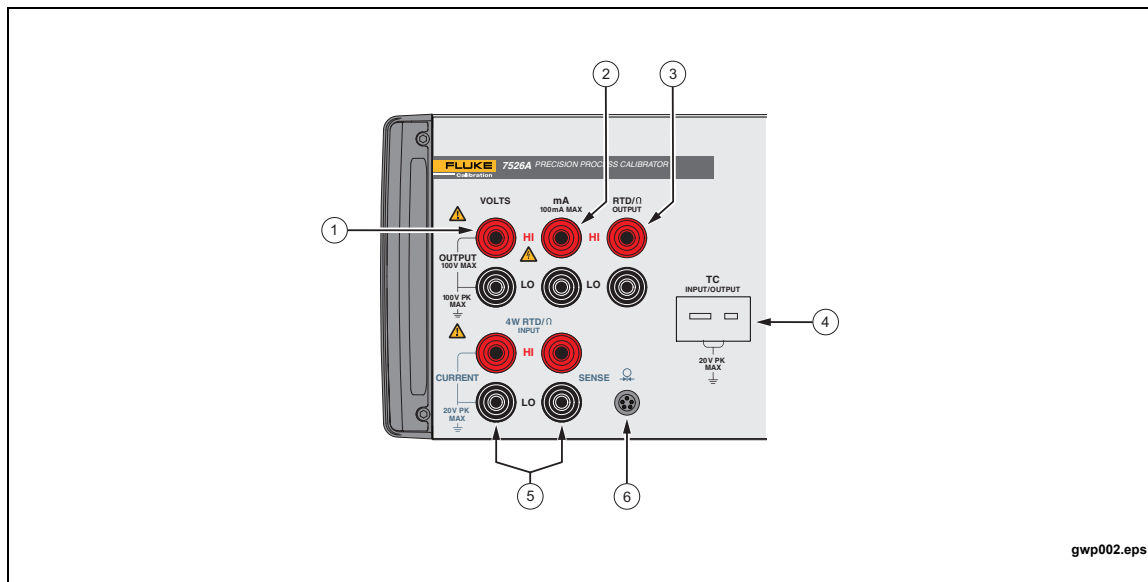

Item	Description
①	<b>VOLTS</b> <sup>[1,2]</sup> – DC voltage output terminals
②	<b>mA</b> <sup>[1,2]</sup> – DC current output terminals
③	<b>RTD/Ω OUTPUT</b> <sup>[1,2]</sup> – Two-wire RTD and ohms output terminals
④	<b>TC INPUT/OUTPUT</b> - Thermocouple input and output terminals. These terminals accept a miniature polarized thermocouple plug with flat in-line blades distanced 7.9 mm (0.312 in.) center to center.
⑤	<b>4W RTD/Ω INPUT</b> <sup>[1,3]</sup> – Four-wire RTD and ohms input terminals
⑥	 Pressure module input connector
[1]	These terminal binding posts are made of a special copper alloy to decrease thermal EMFs. Discreet wires or standard banana plugs can be used. The HI/LO pairs are distanced for standard dual banana plugs.
[2]	<b>⚠⚠ Warning:</b> To prevent possible electrical shock, fire, or personal injury, do not exceed a maximum of 100 V peak to chassis ground.
[3]	<b>⚠⚠ Warning:</b> To prevent possible electrical shock, fire, or personal injury, do not exceed a maximum of 20 V peak to chassis ground.

Figure 1-2. Primary Input/Output Terminals

**Primary Input/Output Display and Controls**

Figure 1-3 shows the primary input/output display and controls.

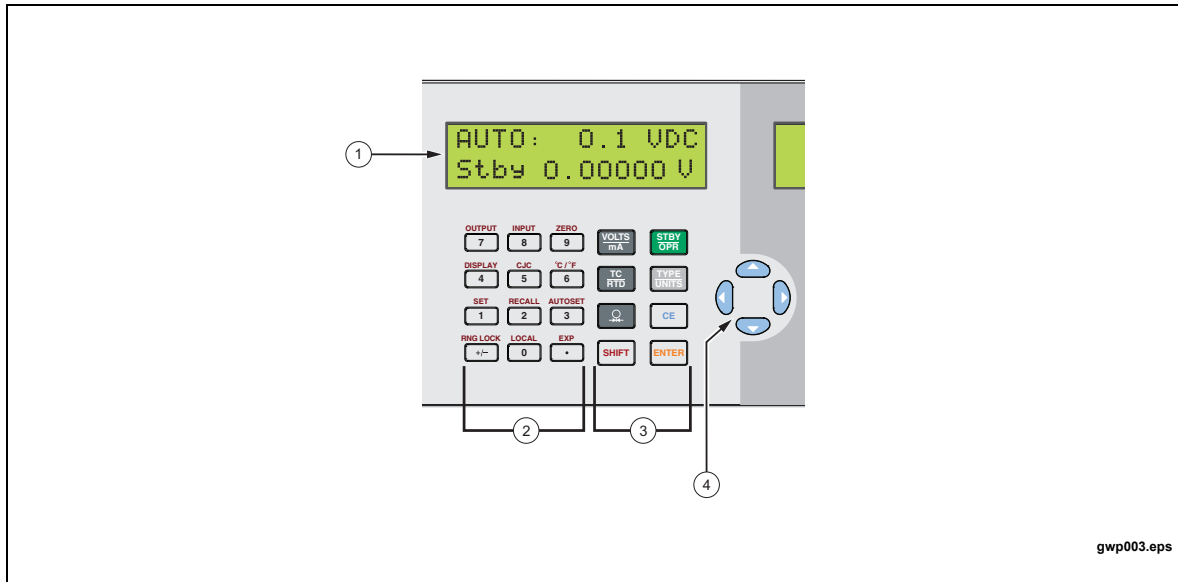

gwp003.eps

Item	Description	
①	<p><b>Display:</b> A two-line, 16-character display that gives all visual user feedback for the primary output and input operations. See the “Display Layout” and “Error Messages” section of this chapter for more information.</p>	
②	<p><b>Numeric and Secondary Function Keys:</b> Output value data entry keys. Secondary function selection per the text printed above the numeric key. Push <b>SHIFT</b> and then the numeric key to select the function.</p>	
	<p><b>SHIFT</b>      OUTPUT                   <b>7</b></p>	<p>Change RTD/Ohms or Thermocouple to output mode.</p>
	<p><b>SHIFT</b>      INPUT                   <b>8</b></p>	<p>Change RTD/Ohms or Thermocouple to input mode.</p>
	<p><b>SHIFT</b>      ZERO                   <b>9</b></p>	<p>Zero the input for Pressure, Thermocouple millivolts, or RTD ohms.</p>
	<p><b>SHIFT</b>      SETUP                   <b>4</b></p>	<p>Adjust the LCD Contrast, LCD Backlight, and Remote Interface Configuration as given in Chapter 5, “LCD and Remote Interface Setup Procedures”.</p>
<p><b>SHIFT</b>      CJC                   <b>5</b></p>	<p>Select internal or external cold junction compensation for Thermocouple temperature measurements. When external compensation is selected, XCJC is shown at the start of the second line.</p>	

**Figure 1-3. Primary Input/Output Display and Controls**









































Item	Description	
②	Numeric and Secondary Function Keys: Output value data entry keys. Secondary function selection per the text printed above the numeric key. Push  and then the numeric key to select the function.	
	 °C/°F 	Select Celsius or Fahrenheit units for RTD and Thermocouple temperature measurements.
	 SET 	Set a new value for a preset output setpoint as given in Chapter 3, "Output Setpoints".
	 RECALL 	Recall a preset output setpoint as given in Chapter 3, "Output Setpoints".
	 AUTOSET 	Start automatic stepping of preset output setpoints as given in Chapter 3, "Output Setpoints".
	 RNG LOCK 	Select Auto-range or Range Lock for voltage output.
	 LOCAL 	Push to regain local control of the Product after the remote command REMOTE is received. In this case, all keys but this one are ignored. When the remote command LOCKOUT is received, all keys are ignored. This includes this key. The remote command LOCAL must be received to regain local control.
 EXP 	Push during entry of a RTD custom curve coefficient to start entry of the exponent.	
③	<b>Function Keys</b>	
		Select dc voltage or current output mode, and toggle between them.
		Select Thermocouple or RTD/Ohms input/output mode, and toggle between them.
		Select Pressure input mode.
	In Thermocouple mode, move through the thermocouple types, this includes millivolts. In RTD/Ohms mode, move through the RTD types, this includes ohms in Pressure mode, move through the pressure units.	

Figure 1-3. Primary Input/Output Display and Controls (cont.)

<b>Function Keys</b>									
③	<table border="1" style="width: 100%; border-collapse: collapse;"> <tr> <td style="text-align: center; width: 20%;"></td> <td>For all but Thermocouple output modes, toggle between Standby and Operate modes. In Standby mode, changes to the output value in the display is not applied to the terminals until you select the Operate mode. In Operate mode, each change to the output value in the display is applied to the terminals immediately. Voltages more than 30 V are not applied to the terminals and the mode automatically reverts to Standby for your safety.</td> </tr> <tr> <td style="text-align: center;"></td> <td>Changes the Product output or parameter to the numeric value typed into the keypad.</td> </tr> <tr> <td style="text-align: center;"></td> <td>Erases a partial keypad entry and reverts the Product output or parameter to its last known value.</td> </tr> <tr> <td style="text-align: center;"></td> <td>Prepares for selection of a secondary function with the numeric keypad. The secondary function is shown above each numeric key. The display changes to SHIFT ENABLED until a numeric key is pushed. To cancel the selection, push  again.</td> </tr> </table>		For all but Thermocouple output modes, toggle between Standby and Operate modes. In Standby mode, changes to the output value in the display is not applied to the terminals until you select the Operate mode. In Operate mode, each change to the output value in the display is applied to the terminals immediately. Voltages more than 30 V are not applied to the terminals and the mode automatically reverts to Standby for your safety.		Changes the Product output or parameter to the numeric value typed into the keypad.		Erases a partial keypad entry and reverts the Product output or parameter to its last known value.		Prepares for selection of a secondary function with the numeric keypad. The secondary function is shown above each numeric key. The display changes to SHIFT ENABLED until a numeric key is pushed. To cancel the selection, push  again.
	For all but Thermocouple output modes, toggle between Standby and Operate modes. In Standby mode, changes to the output value in the display is not applied to the terminals until you select the Operate mode. In Operate mode, each change to the output value in the display is applied to the terminals immediately. Voltages more than 30 V are not applied to the terminals and the mode automatically reverts to Standby for your safety.								
	Changes the Product output or parameter to the numeric value typed into the keypad.								
	Erases a partial keypad entry and reverts the Product output or parameter to its last known value.								
	Prepares for selection of a secondary function with the numeric keypad. The secondary function is shown above each numeric key. The display changes to SHIFT ENABLED until a numeric key is pushed. To cancel the selection, push  again.								
④	<p style="text-align: center;">Cursor Controls</p> <p>Push  or  to put the cursor below the digit in an output value that is to be increased or decreased.</p> <p>Push  to increment the digit in the output value where the cursor is.</p> <p>Push  to decrement the digit in the output value where the cursor is.</p> <p>The  and  keys are also used to adjust LCD Contrast level, LCD Backlight level, and Remote Interface Configuration selections as given in Chapter 5, “LCD and Remote Interface Setup Procedure”.</p>								

**Figure 1-3. Primary Input/Output Display and Controls (cont.)**

### Isolated Input Display, Controls, and Terminals

Figure 1-4 shows the isolated input display, controls, and terminals.

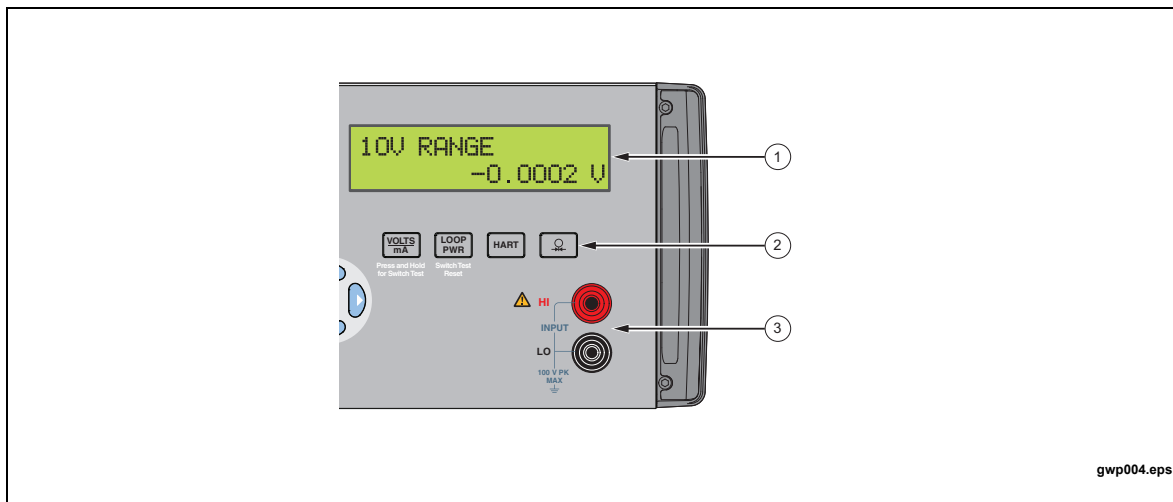





Item	Name	Description
①	Display	A two-line, 16-character display gives all visual user feedback for the isolated input operations. See the “Display Layouts” section of this chapter for layout information, and the “Error Messages” section of this chapter for possible error messages.
<b>Function Keys</b>		
②		<p>This key is used for multiple functions. In normal operation it is used to move through the 50 mA, 10 V and 100 V ranges.</p> <p>If held for 3 seconds it will change the Product into or out of switctest mode. In switctest recall mode it will move through the stored switch test data.</p>
		<p>When you use 24 mA mode to verify a two-wire loop powered transmitter, disconnect it from its wires and push . This turns on an internal 24 V power supply in series with the current measurement circuit. Push the key again to turn off the 24 V supply. In all switch test modes, push this key to start or stop a test.</p>
		<p>When you use 50 mA mode to verify a HART configuration device, push this key to turn on an internal 250 Ω resistor in series. Push the key again to turn off the resistor. Note that when you turn on this resistor, the maximum load-driving functionality drops from 1000 Ω at 20 mA to 750 Ω at 20 mA.</p>

Figure 1-4. Isolated Input Display, Controls, and Terminals

Item	Name	Description
②		Selects Pressure input mode. Subsequent pushes of this key cycle through the pressure units. Pressure input mode uses the pressure module connector on the primary input/output side. Each side can use pressure mode at the same time and can be set to show the same pressure measurement in different units if necessary.
③	Input Terminals <sup>[1,2]</sup>	Common input terminals for dc voltage and current.

[1] These terminal binding posts are made of a special copper alloy to decrease thermal EMF's. Discreet wires or standard banana plugs can be used, and the HI/LO pairs are distanced for standard dual banana plugs.

[2] **⚠️ ⚠️ Warning: To prevent possible electrical shock, fire, or personal injury Do not exceed a maximum of 100 V peak to chassis ground.**

Figure 1-4. Isolated Input Display, Controls, and Terminals (cont.)

**Rear Panel**

Figure 1-5 shows the rear-panel layout.

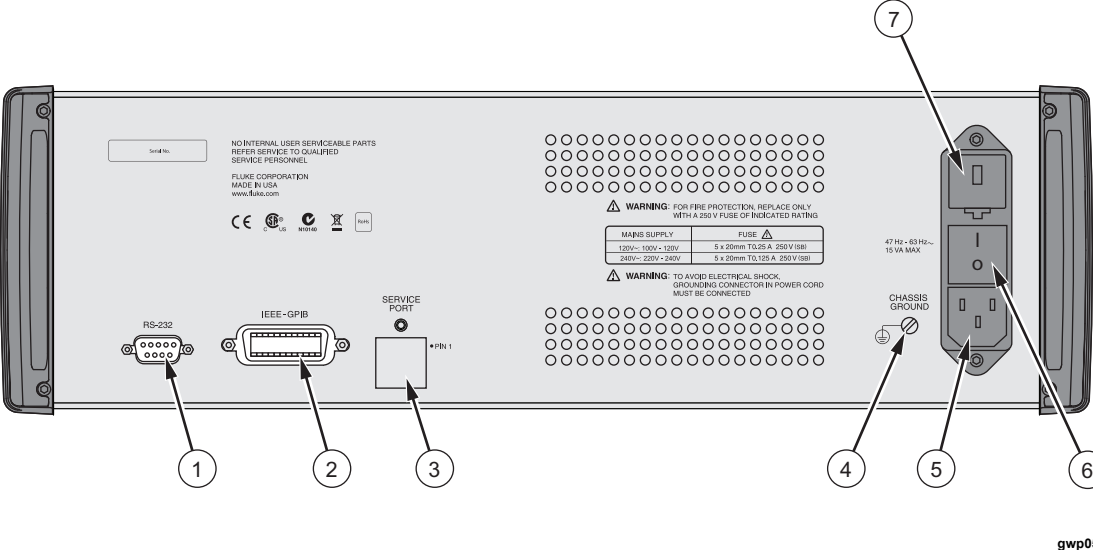

The diagram shows the rear panel of the device with the following components labeled:

- ① RS-232 9-pin connector
- ② IEEE-GPIB connector
- ③ Service port
- ④ Chassis ground terminal
- ⑤ Standard IEC AC power inlet
- ⑥ Main power on/off switch
- ⑦ Power line voltage selector and fuse compartment

Additional text on the panel includes: "NO INTERNAL USER SERVICEABLE PARTS. REFER SERVICE TO QUALIFIED SERVICE PERSONNEL.", "FLUKE CORPORATION MADE IN USA www.fluke.com", and a fuse table:

MAIN SUPPLY	FUSE
120V~ 100V - 120V	5 x 20mm TQ,25 A, 250V (58I)
240V~ 220V - 240V	5 x 20mm TQ,125 A, 250V (58II)

Warnings: "FOR FIRE PROTECTION, REPLACE ONLY WITH A 250 V FUSE OF INDICATED RATING." and "TO AVOID ELECTRICAL SHOCK, GROUNDING CONNECTOR IN POWER CORD MUST BE CONNECTED."

gwp05.eps

Item	Description
①	RS-232 9-pin connector for remote control of the Product with a computer serial interface.
②	GPIB IEEE 488.2 connector for remote control of the Product with a GPIB bus.
③	Service port to update the Product firmware.
④	Chassis ground terminal internally connected to the ground prong of the AC power inlet.
⑤	Standard IEC AC power inlet for 120/240 V ac.
⑥	Main power on/off switch.
⑦	Power line voltage selector and fuse compartment. See Chapter 7, "Maintenance" for instructions to change the line voltage selector and fuses.

Figure 1-5. Rear Panel

**Display Layouts**

Figure 1-6 shows the primary voltage and current display.

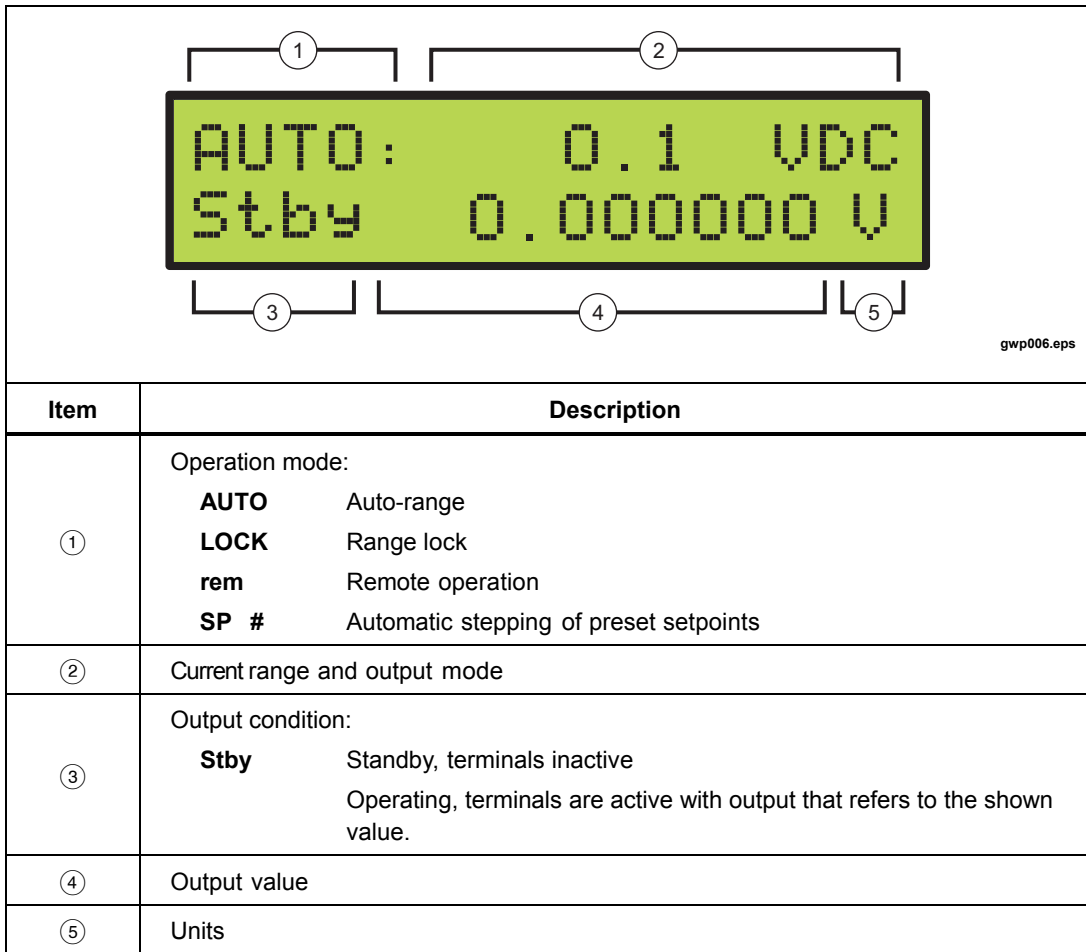

**Figure 1-6. Primary Voltage and Current Display**



Figure 1-7 shows the primary thermocouple and RTD display.

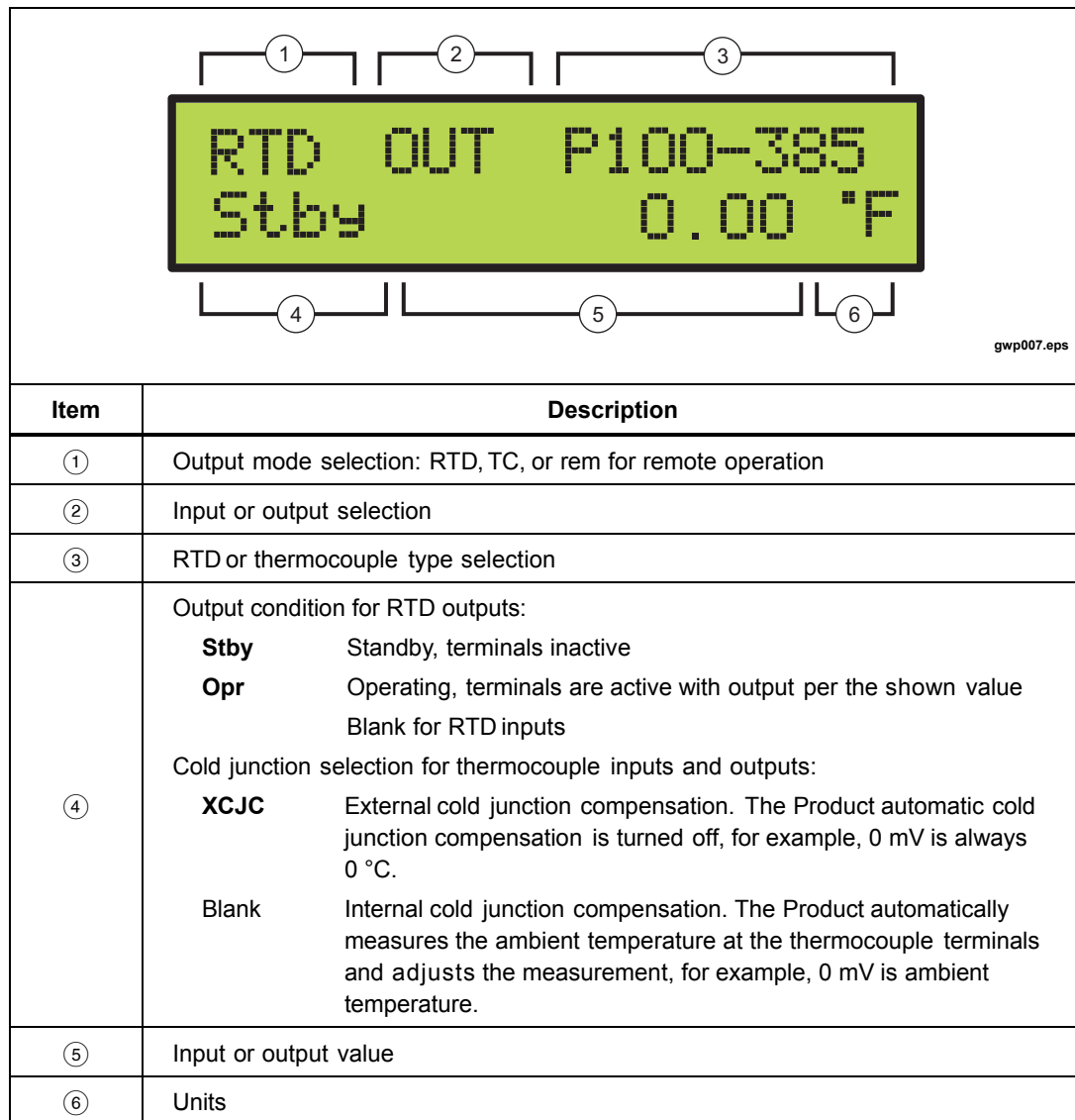

Figure 1-7. Primary Thermocouple and RTD Display

Figure 1-8 shows the primary and isolated pressure display.

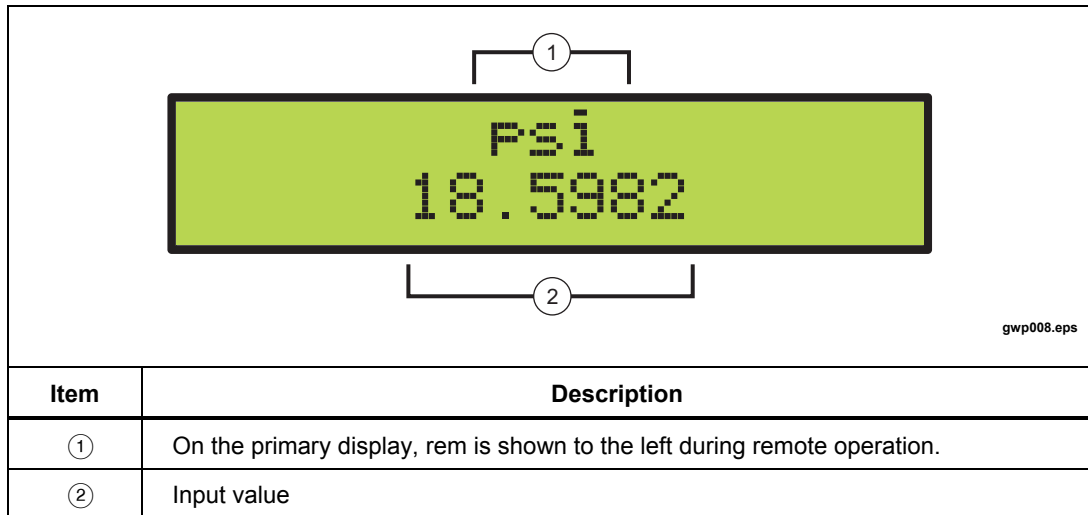

Figure 1-8. Primary and Isolated Pressure Display

Figure 1-9 shows the isolated voltage and current display.

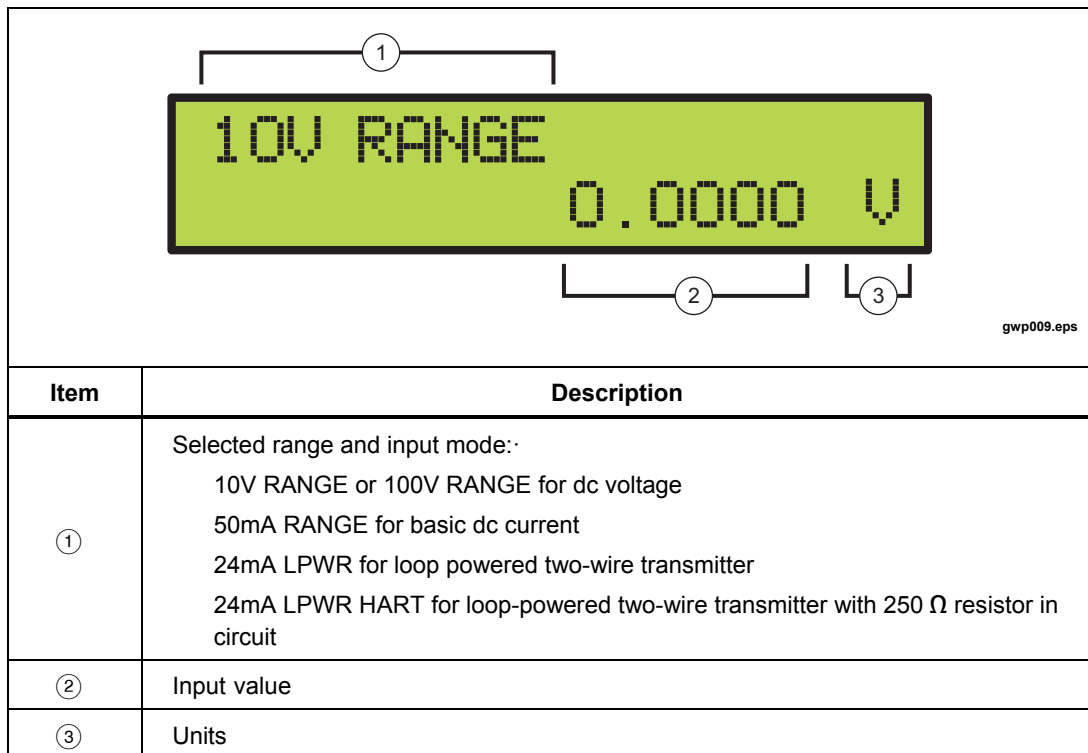

Figure 1-9. Isolated Voltage and Current Display

## Error Messages

Table 1-2 shows the error messages that can appear on the displays.

**Table 1-2. Error Messages**

Message	Description
OVER RANGE	The numeric keypad value is larger than the range of the output mode selected.
OVER LOAD	For dc voltage output mode, the current necessary to make the output is larger than the Product specifications. For dc current mode, the resistance of the circuit is larger than the Product specifications.
OL	For input modes, the measured value is larger than the top limit of the selected input mode range. For output modes, when the range is locked, the current automatically recalled preset setpoint is larger than the maximum limit of the locked range. The output is set to zero for the time of this setpoint.
-OL	For input modes, the measured value is less than the lower limit of the selected input mode range.

## Set Up

Follow the subsequent steps to set up the Product:

### Caution

**Before you connect the mains power cord to the rear connector, make sure that the line voltage selector is in the correct position for your location.**

The Product is shipped from the factory with the line voltage set for the country of purchase. To make sure the line voltage is correctly set, examine the indicator on the power line voltage selector and fuse compartment cover. See the “Rear Panel” section of this chapter.

1. See Table 1-3 to set the correct line voltage.

**Table 1-3. Line-Voltage Settings**

Line Voltage (50/60Hz)	Selector Position
100 V ac to 120 V ac	120 V ac position
220 V ac to 240 V ac	240 V ac position

2. If the line voltage is not correctly set, follow the instructions in “Changing the Line Voltage” in Chapter 7.

3. When the line voltage is correctly set, make sure that the power switch is off and connect the mains power cord to the Product. See the “Rear Panel” section of this chapter, for the location.
4. Turn on the Product with the rear-panel rocker switch. The Product will power up in a few seconds. It briefly shows the model number and firmware version in the primary display before it changes to the correct input/output display.

*Note*

*If a correct power-up display does not occur in 30 seconds, turn off the power. Turn on the unit after a few seconds. If the problem continues, report the problem to Fluke immediately.*

Warmup time is two times the time since its last warmup, to a maximum of 30 minutes. To keep the Product stable, it is best to keep the Product on all the time.

## Specifications

### General Specifications

<b>Warm-up Time</b> .....	Twice the time since last warmed up, to a maximum of 30 minutes
<b>Settling Time</b> .....	Less than 5 seconds for all functions and ranges except as noted
<b>Standard Interfaces</b> .....	RS-232 IEEE-488 (GPIB)
<b>Temperature Performance</b>	
Operating .....	0 °C to 50 °C
Calibration (tcal) .....	18 °C to 28 °C
Storage .....	-20 °C to 70 °C
<b>Electromagnetic Compatibility</b> .....	CE: Conforms to EN61326; operation in controlled EM environments
<b>Temperature Coefficient</b> .....	Temperature coefficient for temperatures outside tcal 5 °C is 10 % of the 90-day specification (or 1 year if applicable) per °C
<b>Relative Humidity</b>	
Operating .....	<80 % to 30 °C <70 % to 40 °C <40 % to 50 °C
<b>Altitude</b>	
Operating .....	3,000 m (9,800 ft) maximum
Non-operating .....	12,200 m (40,000 ft) maximum
<b>Safety</b> .....	EN/IEC 61010-1:2010 3 <sup>rd</sup> Edition, UL 61010-1:2012, CAN/CSA 22.2 No. 61010-1-12
<b>Analog Low Isolation</b> .....	20 V
<b>Line Power</b> Line Voltage (selectable)	
120 V~ .....	100 V to 120 V
240 V~ .....	220 V to 240 V
<b>Line Frequency</b> .....	47 to 63 Hz
<b>Line Voltage Variation</b> .....	±10 % about setting
<b>Power Consumption</b> .....	15 VA maximum
<b>Dimensions</b>	
Height .....	14.6 cm (5.75 inch)
Width .....	44.5 cm (17.5 inch)
Depth .....	29.8 cm (11.75 inch) overall
<b>Weight (without options)</b> .....	4.24 kg (9.35 lb)

**DC Voltage Specifications, Output**

Ranges <sup>[1]</sup>	Absolute Uncertainty tcal ± 5°C, ±(ppm of output +µV)				Stability	Resolution	Maximum Burden <sup>[2]</sup>
	90 Days		1 Year		24 hours, ±1 °C ±(ppm of output +µV)		
0 mV to 100.000 mV	25	3	30	3	5 ppm + 2 µV	1 µV	10 mA
0 V to 1.00000 V	25	10	30	10	4 ppm + 10 µV	10 µV	10 mA
0 V to 10.0000 V	25	100	30	100	4 ppm + 100 µV	100 µV	10 mA
0 V to 100.000 V	25	1 mV	30	1 mV	5 ppm + 1 mV	1 mV	1 mA
TC Output and Input							
-10 to 75.000 mV	25	2 µV	30	2 µV	5 ppm + 2 µV	1 µV	10 Ω
[1] All outputs are positive only, unless otherwise noted. [2] Remote sensing is not provided. Output resistance is <1 Ω							

Noise		
Ranges	Bandwidth 0.1 to 10 Hz p-p ±(ppm of output +µV)	Bandwidth 10 Hz to 10 kHz rms µV
0 mV to 100.000 mV	1 µV	6 µV
0 V to 1.00000 V	10 µV	60 µV
0 V to 10.0000 V	100 µV	600 µV
0 V to 100.000 V	10 ppm+1 mV	20 mV

**DC Voltage Specifications, Isolated Input**

Ranges	Absolute Uncertainty, tcal ±5 °C, ±(ppm of reading + mV)		Resolution
0 V to 10.0000 V	50	0.2	100 µV
0 V to 100.000 V	50	2.0	1 mV

**DC Current Specifications, Output**

Ranges <sup>[1]</sup>	Absolute Uncertainty, tcal ±5 °C ± (ppm of output +µA)				Resolution	Maximum Compliance Voltage	Maximum Inductive Load
	90 Days		1 Year				
0 mA to 100.000 mA	40 <sup>[2]</sup>	1	50 <sup>[2]</sup>	1	1 µA	12 V	100 mH
[1] All outputs are positive only. [2] For line voltages less than 95 V (±100 ppm of reading).							

Ranges	Noise	
	Bandwidth 0.1 to 10 Hz p-p	Bandwidth 10 Hz to 10 kHz rms µV
0 mA to 100.000 mA	2000 nA	20 µA

**DC Current Specifications, Isolated Input**

Ranges	Absolute Uncertainty, tcal ±5 °C, ±(ppm of reading + µA)		Resolution
0 mA to 50.0000 mA	100	1	0.1 µA
0 mA to 24.0000 mA (Loop Power) <sup>[1][2]</sup>	100	1	0.1 µA
[1] Loop Power: 24 V ±10 % [2] HART Resistor: 250 Ω ±3 %			

**Resistance Specifications, Output**

Ranges	Absolute Uncertainty, tcal $\pm 5$ °C, $\pm$ Ohms		Resolution	Nominal Current <sup>[1]</sup>
	90 Days	1 Year		
5 $\Omega$ to 400.000 $\Omega$	0.012	0.015	0.001 $\Omega$	1 to 3 mA
5 k $\Omega$ to 4.00000 k $\Omega$	0.25	0.3	0.01 $\Omega$	100 $\mu$ A to 1 mA
<p>[1] For currents lower than shown, the specification becomes            New Spec. = Stated Spec. x Imin/lactual.            For example, a 500 <math>\mu</math>A stimulus that measures 100 <math>\Omega</math> has a specification of: 0.015 <math>\Omega</math> x 1 mA/500 <math>\mu</math>A=0.03 <math>\Omega</math></p>				

**Resistance Specifications, Input**

Ranges	Absolute Uncertainty, tcal $\pm 5$ °C $\pm$ (ppm of reading + $\Omega$ )		Resolution	Stimulus Current
	90 Days	1 Year		
0 $\Omega$ to 400.000 $\Omega$	$\pm 20$ ppm + 0.0035 $\Omega$	$\pm 20$ ppm + 0.004 $\Omega$	0.001 $\Omega$	1 mA
0 k $\Omega$ to 4.00000 k $\Omega$	$\pm 20$ ppm + 0.035 $\Omega$	$\pm 20$ ppm + 0.04 $\Omega$	0.01 $\Omega$	0.1 mA

**Thermocouple Specification, Output and Input**

TC Type	Range (°C)		Absolute Uncertainty, tcal ±5 °C, ±(°C) <sup>[1]</sup>	
			Output/Input	
	Minimum	Maximum	90 days	1 Year
B	600 °C	800 °C	0.35 °C	0.35 °C
	800 °C	1550 °C	0.28 °C	0.28 °C
	1550 °C	1820 °C	0.21 °C	0.22 °C
C	0 °C	1000 °C	0.15 °C	0.16 °C
	1000 °C	1800 °C	0.22 °C	0.23 °C
	1800 °C	2000 °C	0.24 °C	0.26 °C
	2000 °C	2316 °C	0.32 °C	0.35 °C
E	-250 °C	-200 °C	0.24 °C	0.25 °C
	-200 °C	-100 °C	0.10 °C	0.12 °C
	-100 °C	0 °C	0.07 °C	0.09 °C
	0 °C	600 °C	0.06 °C	0.08 °C
	600 °C	1000 °C	0.08 °C	0.10 °C
J	-210 °C	-100 °C	0.13 °C	0.14 °C
	-100 °C	800 °C	0.07 °C	0.09 °C
	800 °C	1200 °C	0.08 °C	0.10 °C
K	-250 °C	-200 °C	0.45 °C	0.46 °C
	-200 °C	-100 °C	0.15 °C	0.16 °C
	-100 °C	500 °C	0.08 °C	0.10 °C
	500 °C	800 °C	0.09 °C	0.10 °C
	800 °C	1372 °C	0.11 °C	0.13 °C
L	-200 °C	-100 °C	0.08 °C	0.10 °C
	-100 °C	900 °C	0.07 °C	0.09 °C
N	-250 °C	-200 °C	0.72 °C	0.73 °C
	-200 °C	-100 °C	0.22 °C	0.23 °C
	-100 °C	0 °C	0.11 °C	0.12 °C
	0 °C	100 °C	0.09 °C	0.11 °C
	100 °C	800 °C	0.08 °C	0.10 °C
	800 °C	1300 °C	0.10 °C	0.12 °C
R	-50 °C	-25 °C	0.54 °C	0.55 °C
	-25 °C	0 °C	0.44 °C	0.45 °C
	0 °C	100 °C	0.38 °C	0.39 °C
	100 °C	400 °C	0.27 °C	0.28 °C
	400 °C	600 °C	0.21 °C	0.22 °C
	600 °C	1000 °C	0.19 °C	0.21 °C
	1000 °C	1600 °C	0.18 °C	0.19 °C
	1600 °C	1767 °C	0.21 °C	0.23 °C
S	-50 °C	-25 °C	0.51 °C	0.51 °C
	-25 °C	0 °C	0.43 °C	0.43 °C
	0 °C	100 °C	0.37 °C	0.38 °C
	100 °C	400 °C	0.28 °C	0.29 °C
	400 °C	600 °C	0.22 °C	0.23 °C
	600 °C	1000 °C	0.21 °C	0.22 °C
	1000 °C	1600 °C	0.20 °C	0.22 °C
	1600 °C	1767 °C	0.24 °C	0.26 °C

TC Type	Range (°C)		Absolute Uncertainty, tcal ±5 °C, ±(°C) <sup>[1]</sup>	
			Output/Input	
	Minimum	Maximum	90 days	1 Year
T	-250 °C	-200 °C	0.34 °C	0.35 °C
	-200 °C	-100 °C	0.14 °C	0.16 °C
	-100 °C	0 °C	0.09 °C	0.11 °C
	0 °C	200 °C	0.07 °C	0.09 °C
	200 °C	400 °C	0.06 °C	0.09 °C
U	-200 °C	0 °C	0.15 °C	0.16 °C
	0 °C	200 °C	0.08 °C	0.10 °C
	200 °C	600 °C	0.07 °C	0.10 °C
XK	-200 °C	-100 °C	0.10 °C	0.11 °C
	-100 °C	0 °C	0.07 °C	0.09 °C
	0 °C	600 °C	0.06 °C	0.08 °C
	600 °C	800 °C	0.07 °C	0.09 °C
BP	0 °C	200 °C	0.17 °C	0.18 °C
	200 °C	600 °C	0.14 °C	0.16 °C
	600 °C	800 °C	0.15 °C	0.17 °C
	800 °C	1600 °C	0.22 °C	0.23 °C
	1600 °C	2000 °C	0.26 °C	0.28 °C
	2000 °C	2500 °C	0.38 °C	0.40 °C

[1] Does not include thermocouple wire error.  
 Type B, E, J, K, N, R, S and T are based on ITS-90  
 Type L and U are based on DIN 43710-1985  
 Type C is based on ASTM standard E 988-96  
 Type XK and BP are based on GOST R 8.585-2001

### RTD and Thermistor Specification, Output

RTD Types	Range °C		Absolute Uncertainty, tcal ±5 °C ±(°C) <sup>[1]</sup>	
	Minimum	1 Year	90 Days	1 Year
Pt 385, 100 Ω	-200 °C	-800 °C	0.04 °C	0.05 °C
Pt 3926, 100 Ω	-200 °C	630 °C	0.04 °C	0.05 °C
Pt 3916, 100 Ω	-200 °C	630 °C	0.04 °C	0.05 °C
Pt 385, 200 Ω	-200 °C	400 °C	0.35 °C	0.40 °C
	400 °C	630 °C	0.42 °C	0.50 °C
Pt 385, 500 Ω	-200 °C	630 °C	0.15 °C	0.17 °C
Pt 385, 1000 Ω	-200 °C	630 °C	0.07 °C	0.09 °C
Ni 120, 120 Ω	-80 °C	260 °C	0.02 °C	0.02 °C
Cu 427, 10 Ω <sup>[2]</sup>	-100 °C	260 °C	0.30 °C	0.38 °C
YSI 400	15 °C	50 °C	0.005 °C	0.007 °C

[1] 2-wire output  
 [2] Based on MINCO Application Aid No. 18



**RTD and Thermistor Specification, Input**

RTD Type	Range (°C)		Absolute Uncertainty, tcal ±5 °C, ±(°C) <sup>[1]</sup>	
			Output/Input	
	Minimum	Maximum	90 Days	1 Year
Pt 385, 100 Ω	-200 °C	-80 °C	0.012 °C	0.013 °C
	-80 °C	100 °C	0.018 °C	0.020 °C
	100 °C	300 °C	0.022 °C	0.024 °C
	300 °C	400 °C	0.025 °C	0.026 °C
	400 °C	630 °C	0.031 °C	0.033 °C
	630 °C	800 °C	0.037 °C	0.038 °C
Pt 3926, 100 Ω	-200 °C	-80 °C	0.012 °C	0.013 °C
	-80 °C	0 °C	0.014 °C	0.015 °C
	0 °C	100 °C	0.016 °C	0.017 °C
	100 °C	300 °C	0.022 °C	0.022 °C
	200 °C	400 °C	0.022 °C	0.026 °C
	400 °C	630 °C	0.024 °C	0.032 °C
Pt 3916, 100 Ω	-200 °C	-190 °C	0.009 °C	0.010 °C
	-190 °C	-80 °C	0.012 °C	0.013 °C
	-80 °C	0 °C	0.014 °C	0.015 °C
	0 °C	100 °C	0.016 °C	0.017 °C
	100 °C	300 °C	0.021 °C	0.022 °C
	300 °C	400 °C	0.024 °C	0.026 °C
	400 °C	600 °C	0.030 °C	0.031 °C
	600 °C	630 °C	0.031 °C	0.033 °C
Pt 385, 200 Ω	-200 °C	-80 °C	0.047 °C	0.053 °C
	-80 °C	0 °C	0.050 °C	0.056 °C
	0 °C	100 °C	0.053 °C	0.060 °C
	100 °C	260 °C	0.054 °C	0.060 °C
	260 °C	300 °C	0.062 °C	0.069 °C
	300 °C	400 °C	0.064 °C	0.071 °C
	400 °C	630 °C	0.079 °C	0.088 °C
	-80 °C		0.031 °C	
Pt 385, 500 Ω	-200 °C	0 °C	0.023 °C	0.025 °C
	0 °C	100 °C	0.026 °C	0.028 °C
	100 °C	300 °C	0.031 °C	0.034 °C
	300 °C	400 °C	0.035 °C	0.038 °C
	400 °C	630 °C	0.041 °C	0.045 °C
Pt 385, 1000 Ω	-200 °C	0 °C	0.014 °C	0.015 °C
	0 °C	100 °C	0.017 °C	0.018 °C
	100 °C	300 °C	0.022 °C	0.024 °C
	300 °C	400 °C	0.024 °C	0.026 °C
	400 °C	630 °C	0.031 °C	0.033 °C
Ni 120, 120 Ω	-80 °C	260 °C	0.008 °C	0.009 °C
Cu 427, 10 Ω <sup>[2]</sup>	-100 °C	260 °C	0.097 °C	0.110 °C
YSI 400	15 °C	50 °C	0.005 °C	0.007 °C
SPRT	-200 °C	660 °C	0.05 °C	0.06 °C

[1] 4-wire mode. Uncertainties shown do not include probe uncertainties.  
 [2] Based on MINCO Application Aid No. 18.

**Pressure Measurement Specifications**

The Calibrator can accept the Fluke 700 or 525A-P Series pressure modules. Pressure modules connect directly into the front panel Lemo connector with the Calibrator firmware auto-detecting the type and value of the module you connect.

Range	Accuracy and Resolution	Units
Determined by the pressure module	Determined by the pressure module	PSI (pounds per square inch)
		in H2O 4 °C (inches of water at 4 degrees Celsius)
		in H2O 20 °C (inches of water at 20 degrees Celsius)
		in H2O 60 °C (inches of water at 60 degrees Fahrenheit)
		cm H2O 4 °C (centimeters of water at 4 degrees Celsius)
		cm H2O 20 °C (centimeters of water at 20 degrees Celsius)
		mm H2O 4 °C (millimeters of water at 4 degrees Celsius)
		mm H2O 20 °C (millimeters of water at 20 degrees Celsius)
		BAR (bars)
		mBAR (millibars)
		kPa (kilopascals)
		MPa (megapascals)
		in HG 0 °C (inches of mercury at 0 degrees Celsius)
		mm HG 0 °C (millimeters of mercury at 0 degrees Celsius)
		kg/cm2 (kilograms per square centimeter)

**Switch Test Specifications, Isolated Input**

Contact Closure Resistance	<1 kΩ
Excitation Current	27 mA Max

# **Chapter 2**

## ***Primary Inputs and Outputs***

<b>Title</b>	<b>Page</b>
Introduction.....	2-3
DC Voltage Output.....	2-3
DC Current Output.....	2-4
Resistance Temperature Detector (RTD) and Ohms Measure.....	2-5
Resistance Temperature Detector (RTD) and Ohms Source .....	2-6
Resistance Temperature Detector (RTD) with Custom Coefficients.....	2-7
Standard Platinum Resistance Thermometer (SPRT) Coefficients .....	2-8
Thermocouple (TC) Measure.....	2-9
Thermocouple (TC) Source .....	2-11
Pressure Measure .....	2-12



## Introduction

This chapter explains the main (primary) inputs and outputs of the Product. Connection figures are also shown so that you properly connect the Product to a unit under test (UUT).

## DC Voltage Output

The Product can source dc voltages from 0 V to 100 V and uses these four ranges for maximum accuracy:

- 0.1 V
- 1 V
- 10 V
- 100 V

For dc voltage output:

1. Disconnect test leads from external devices.
2. Push **VOLTS/mA SW TEST** to select dc voltage and current mode, if not already selected.
3. If dc current mode is shown, push the key again to go to dc voltage mode.
4. Connect the UUT to the voltage output terminals of the Product as shown in Figure 2-1.

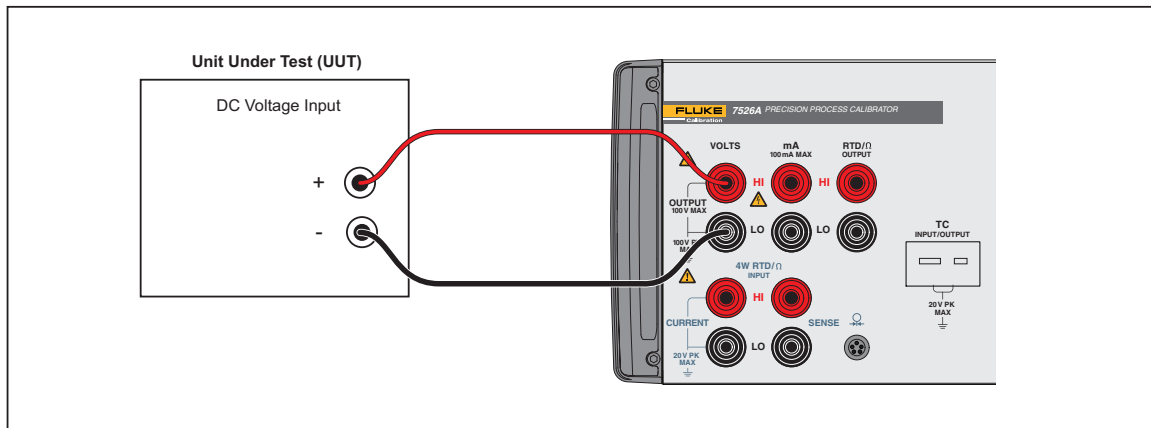

Figure 2-1. DC Voltage Output Connections

gwp010.eps

5. Use the numeric keypad to type the necessary output value and push **ENTER**.
6. As an alternative, use **▲** or **▼** to select a digit to change, followed by **▲** or **▼** to ramp the digit up or down. This method gives you a simple solution when small changes to an output value are necessary, or if is necessary to increment or decrement decades.
7. When dc voltage mode is first selected, the Product is put into standby (Stby) mode which puts the positive (+) output jack into a high-impedance condition ( $>100\text{ k}\Omega$ ) for safety. To put the output into the active condition, push **STBY OPR** to toggle between the standby and operate modes.
8. The standby mode is also started in these situations:
  - If a fault occurs during operation, such as an overload or short circuit condition.
  - As a safety feature for all new outputs larger than 30 V dc. Refer to the product specification section of this manual for maximum drive currents.

### Notes

Scrolling the output when the output value is already larger than 30 V will not place the Calibrator in standby mode for each new value.

Automatic setpoints higher than 30 V will not put the Calibrator in standby mode for each new value.

9. The Product can be locked to a specified voltage range. Select a value in that range and then push **SHIFT** and **+/-** to select the secondary RNG LOCK function.

## DC Current Output

The Product can source dc current from 0 mA to 100 mA.

1. Disconnect test leads from external devices.
2. Push **VOLTS mA** to select dc voltage and current mode, if not already selected.
3. If dc voltage mode is shown, push the key again to go to dc current mode.
4. Connect the UUT to the current output terminals of the Product as shown in Figure 2-2.

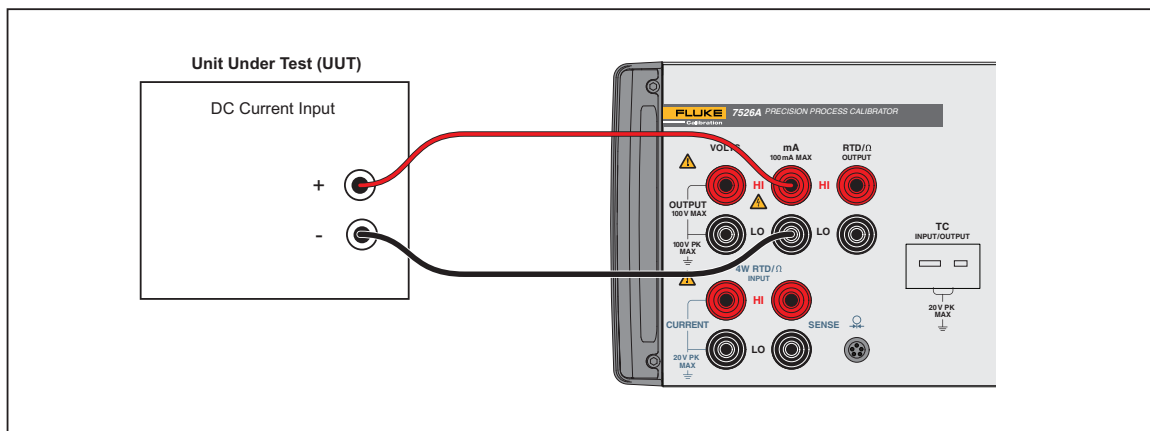

Figure 2-2. DC Current Output Connection

gwp011.eps

5. Use the numeric keypad to type the necessary output value and push **ENTER**.  
As an alternative, use **←** or **→** cursor key to select a digit to change, followed by **▲** or **▼** to move the digit up or down. This method gives you a simple solution when small changes to an output value are necessary, or if is necessary to increment or decrement decades.
6. When dc current mode is first selected, the Product is put into standby (Stby) mode which puts the positive (+) output jack into a high impedance condition ( $>100\text{ k}\Omega$ ) for safety. To put the output into the active condition, push **STBY OPR** to toggle between the standby and operate modes.

The standby mode also operates in these situations:

- No connection made to the output terminals.
- The voltage compliance is larger than a given output current. The Product has a typical-voltage compliance of 10 V. This is so that the 4 mA-20 mA application loads to a maximum of  $500\ \Omega$  can be driven. At maximum current of 100 mA, the maximum load is  $100\ \Omega$ .

## Resistance Temperature Detector (RTD) and Ohms Measure

The Product can measure all common RTD types, 5 custom RTD curves, and a custom SPRT in °F or °C, plus basic resistance from 0 Ω to 4000 Ω. The Product uses these common RTD types:

- Pt 385                    100 Ω, 200 Ω, 500 Ω, 1000 Ω
- Pt 3926                 100 Ω
- Pt 3916 (JIS)         100 Ω
- Ni120                    120 Ω
- Cu 427 (Minco)      10 Ω
- YSI 400

Disconnect test leads from external devices.

1. Push **TC**/**RTD** to select thermocouple and RTD/Ω mode, if not already selected. If thermocouple mode is shown, push the key again to go to RTD/Ω mode.
2. If output mode is shown, push **SHIFT** and **8** to select input mode.
3. Push **TYPE**/**UNITS** to select the necessary RTD type, the custom curve, the SPRT, or the necessary ohms range. The setup and use of custom RTD coefficients is given in the “Resistance Temperature Detector (RTD) with Custom Coefficients” section of this chapter. The set up and use of SPRT coefficients is given in the “Standard Platinum Resistance Thermometer (SPRT) Coefficients” section of this chapter.
4. Connect the UUT to the 4-wire RTD/Ω input terminals of the Product as shown in Figure 2-3.

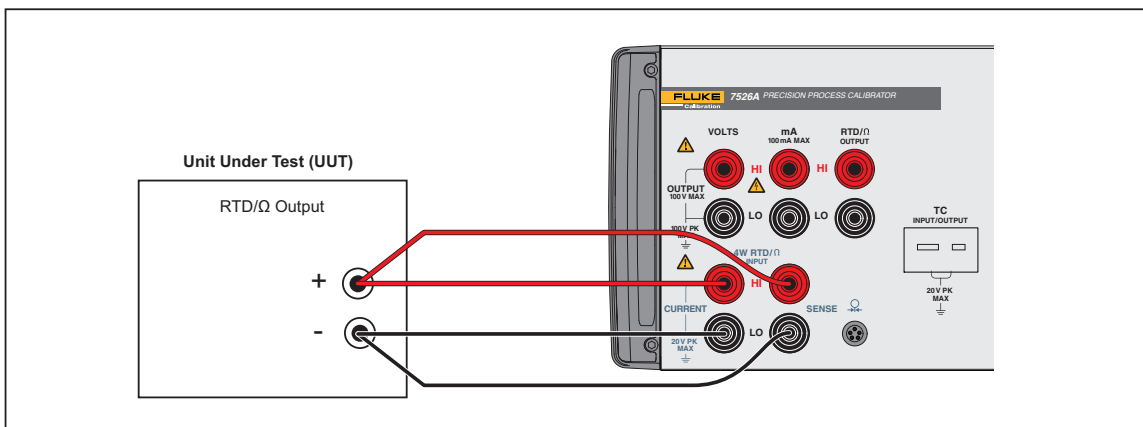

**Figure 2-3. RTD/Ω Input Connection**

gwp012.eps

5. Push **SHIFT** and **6** to toggle the RTD display between °F and °C.
6. For best accuracy, it is recommended to zero the RTD resistance circuit(s) daily, or if you will use the Product out of the ambient temperature range of 18 °C to 28 °C. The maximum offset from unit calibration that can be zeroed out is ±0.1 Ω for the high range and ±0.01 Ω for the low range.

To zero a RTD resistance circuit:

- Select the RTD measure function as in the “Resistance Temperature Detector (RTD) and Ohms Measure” and “Resistance Temperature Detector (RTD) and Ohms Source” sections of this chapter and push **TYPE UNITS** until the low or high ohms range is selected.
- Short the RTD/ $\Omega$  terminals with the test leads normally used for RTD/ $\Omega$  measurements.
- It is necessary for the test leads and terminals to stabilize to the same temperature. They are stable in approximately 3 minutes.
- Push **SHIFT** and **9** to zero the ohms range.

## Resistance Temperature Detector (RTD) and Ohms Source

The Product can source all common RTD types and 5 custom RTD curves in °F or °C, plus basic resistance from 5  $\Omega$  to 4000  $\Omega$ .

The Product uses these common RTD types:

- Pt 385                    100  $\Omega$ , 200  $\Omega$ , 500  $\Omega$ , 1000  $\Omega$
- Pt 3926                 100  $\Omega$
- Pt 3916 (JIS)         100  $\Omega$
- Ni120                    120  $\Omega$
- Cu 427 (Minco)     10  $\Omega$
- YSI 400

1. Disconnect test leads from external devices.
2. Push **TC RTD** to select thermocouple and RTD/ $\Omega$  mode, if not already selected. If thermocouple mode is shown, push the key again to go to RTD/ $\Omega$  mode.
3. If input mode is shown, push **SHIFT** and **7** to select output.
4. Push **TYPE UNITS** to select the necessary RTD curve or ohms range. The set up and use of custom RTD coefficients is given in the “Resistance Temperature Detector (RTD) with Custom Coefficients” section of this chapter.
5. Connect the UUT to the RTD/ $\Omega$  output terminals of the Product as shown in Figure 2-4.

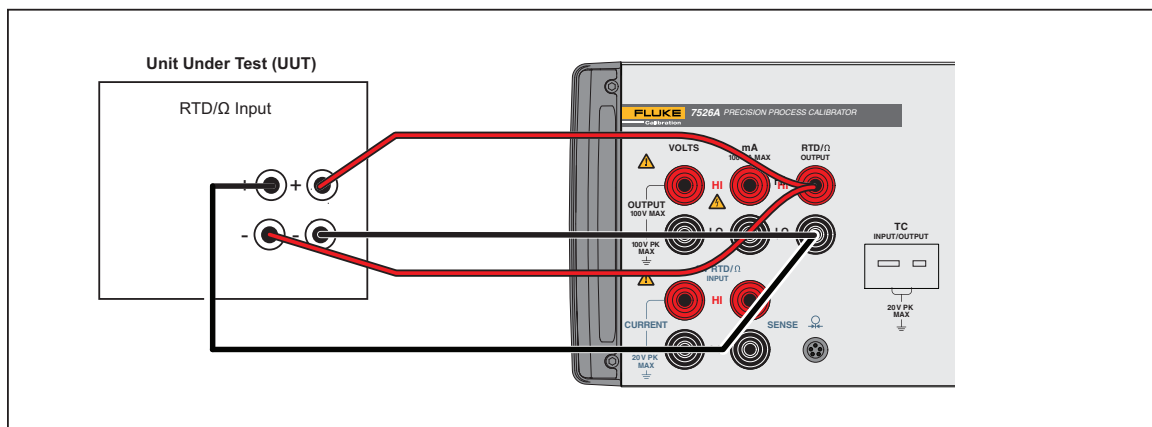

Figure 2-4. RTD/ $\Omega$  Output Connection

gwp013.eps



6. Push **SHIFT** and **6** to toggle the RTD display between °F and °C.
7. Use the numeric keypad to type the necessary output value and push **ENTER**.
10. As an alternative, use **▲** or **▼** to select a digit to change, followed by **▶** or **◀** to ramp the digit up or down. This method gives you a simple solution when small changes to an output value are necessary, or if is necessary to increment or decrement decades.

When RTD/Ω mode is first selected, the Product is put into standby (Stby) mode which puts the positive (+) output jack into a high-impedance condition (>100 k Ω) for safety. To put the output into the active condition, push **STBY OPR** to toggle between the standby and operate modes.

## Resistance Temperature Detector (RTD) with Custom Coefficients

The Product can store coefficients for a maximum of five custom RTD curves. To key in the coefficients for a custom RTD curve:

1. Select RTD measure or source mode as given in the “Resistance Temperature Detector (RTD) and Ohms Measure” or “Resistance Temperature Detector (RTD) and Ohms Source” sections of this chapter.
2. Push **TYPE UNITS** until the USR\_DEF type is selected.
3. Push **ENTER** to show the curve selection prompt "RTD CUSTOM (1-5)".
4. Push the numeric key that goes with the custom RTD curve to be keyed in.
5. At the "SET(1)/RECALL(2)" prompt, push **1** to select custom RTD curve data entry.
6. At the "ENTER MIN TEMP" prompt, key in the minimum temperature limit for the custom RTD curve, and push **ENTER**.
7. At the "ENTER MAX TEMP" prompt, key in the maximum temperature limit for the custom RTD curve, and push **ENTER**.
8. At the "ENTER R0" prompt, key in the nominal resistance value (R0) for the custom RTD curve, and push **ENTER**.
9. At the "ENTER COEFF A" prompt, key in the first (A) coefficient for the custom RTD curve, and push **ENTER**. To key in a coefficient that includes an exponent, key in the mantissa, push **SHIFT** and **.** to select the EXP function, key in the exponent, and push **ENTER**.
10. When prompted, key in the second (B) and third (C) coefficients in the same manner.
11. To abort the curve entry without stored changes, push **TC RTD**.

To use a custom RTD curve:

1. Select RTD measure or source mode as given in the “Resistance Temperature Detector (RTD) and Ohms Measure” or “Resistance Temperature Detector (RTD) and Ohms Source” sections of this chapter.
2. Push **TYPE UNITS** until the USR\_DEF type is selected.
3. Push **ENTER** to show the curve selection prompt “RTD CUSTOM (1-5)”.
4. Push the numeric key that goes with the custom RTD curve to be used.
5. At the "SET(1)/RECALL(2)" prompt, push **2** to recall the custom RTD curve coefficients.

- To use a different custom RTD curve, push **TC RTD** two times to show the USR\_DEF selection prompt.

The USR\_DEF function of the Product uses the Callendar-Van Dusen equation to source and measure custom RTD's. The C coefficient is only used for the subrange -260 °C to 0 °C. Only the A and B coefficients are necessary for the subrange 0 °C to 630 °C. The R0 value is the resistance of the probe at 0 °C.

All five of the custom RTD curves are set to PT385 at the factory, as shown in Table 2-1.

**Table 2-1. Default Custom RTD Coefficients**

Curve	Subrange	R0	Coefficient A	Coefficient B	Coefficient C
1	0 to 630	100	3.9083e10-3	-5.775e10-7	0
2	-260 to 0	100	3.9083e10-3	-5.775e10-7	-4.183e10-12
3	0 to 630	100	3.9083e10-3	-5.775e10-7	0
4	-260 to 0	100	3.9083e10-3	-5.775e10-7	-4.183e10-12
5	0 to 630	100	3.9083e10-3	-5.775e10-7	0

Table 2-2 shows the coefficients for RTD types PT391 and PT392. The C coefficient is only used for temperatures less than 0 °C.

**Table 2-2. Other Common RTD Coefficients**

RTD Type	R0	Coefficient A	Coefficient B	Coefficient C
PT392	100	3.9848e10-3	-5.87e10-7	-4.0e10-12
PT391	100	3.9692e10-3	-5.8495e10-7	-4.2325e10-12

## Standard Platinum Resistance Thermometer (SPRT) Coefficients

The SPRT function of the Product uses ITS-90 standard coefficients as a basis to measure a SPRT. The five custom coefficients are keyed in as deviations from the standard coefficients, and as such, all of them are set to zero at the factory.

The coefficients A- and B- refer to the A4 and B4 coefficient. These are received when the SPRT is calibrated at the triple points of argon, mercury, and water. This includes the 83.8058 K to 273.16 K subrange. Coefficients A, B, and C refer to different coefficients based on which subranges of the SPRT were calibrated. For example, if the 273.15 K to 933.473 K subrange was used, A, B, and C would refer to A7, B7, and C7 whereas if the 273.15 K to 692.67 K subrange was used, A and B would refer to A8 and B8 and C=0.

To key in the deviation coefficients for a custom SPRT:

- Select RTD measure mode as given in the "Resistance Temperature Detector (RTD) and Ohms Measure" section of this chapter.
- Push **TYPE UNITS** until the SPRT type is selected.
- Push **ENTER** to show the prompt "SET(1)/RECALL(2)".
- Push **1** to select custom SPRT data entry.
- At the "ENTER MIN TEMP" prompt, key in the minimum temperature limit for the custom SPRT, and push **ENTER**.
- At the "ENTER MAX TEMP" prompt, key in the maximum temperature limit for the

- custom SPRT, and push .
7. At the "ENTER RTPW" prompt, key in the nominal resistance value (RTPW) for the custom SPRT, and push .
  8. At the "ENTER COEFF A" prompt, key in the first (A) deviation coefficient for the custom SPRT, and push . To key in a coefficient that includes an exponent, key in the mantissa, push  and  to select the EXP function, key in the exponent, and push .
  9. When prompted, use the same method to key in the second (B), third (C), fourth (A-), and fifth (B-) deviation coefficients.
  10. To abort the SPRT entry without stored changes, push .

To use a custom SPRT:

1. Select RTD measure mode as given in the "Resistance Temperature Detector (RTD) and Ohms Measure" section of this chapter.
2. Push  until the SPRT type is selected.
3. Push  to show the prompt "SET(1)/RECALL(2)".
4. Push  to recall the custom SPRT curve coefficients.
5. To use a different custom SPRT, push  two times to show the SPRT selection prompt.

## Thermocouple (TC) Measure

The Product can measure all common thermocouple types in °F or °C, plus basic millivolts from -10.0 to 75.0 mV.

The Product uses these common thermocouple types:

- B
- C
- E
- J
- K
- L
- N
- R
- S
- T
- U
- XK
- BP

1. Disconnect test leads from external devices.
2. Push  to select thermocouple and RTD/Ω mode, if not already selected. If RTD/Ω mode is shown, push the key again to go to thermocouple mode.
3. If output mode is shown, push  and  to select input.

4. Push **TYPE UNITS** to select the necessary thermocouple type or the millivolt range.
5. Connect the UUT to the thermocouple terminals of the Product with a standard TC miniplug as shown in Figure 2-5. One pin is wider than the other. Do not push the plug into the incorrect polarization. The TC wire used for the connection must agree with the thermocouple type selected for correct cold junction compensation. It is necessary for the miniplug and terminals to stabilize to the same temperature. They are stable in approximately 3 minutes.

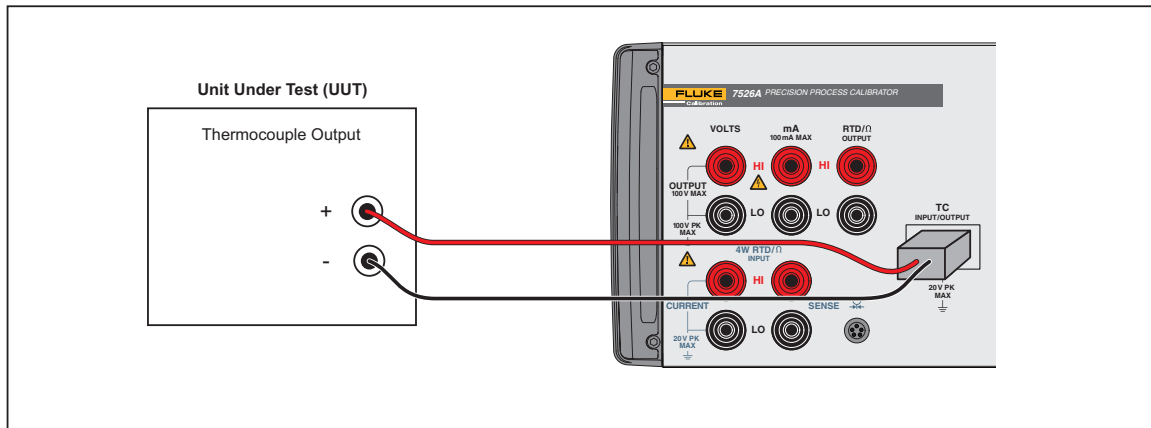

gwp014.eps

Figure 2-5. Thermocouple Input Connection

6. Push **SHIFT** and **6** to toggle the thermocouple display between °F and °C.
7. Push **SHIFT** and **5** to toggle the cold junction compensation between the internal temperature sensor and an external reference.
8. For best accuracy, it is recommended to zero the TC millivolt circuit daily, or if the Product is used out of its ambient temperature range of 18 °C to 28 °C. The maximum offset from unit calibration that can be zeroed out is  $\pm 1$  mV.

To zero the TC millivolt circuit:

1. Select the thermocouple measure function and push **TYPE UNITS** until the millivolt range is selected.
2. Put the supplied thermocouple shorting jumper into the thermocouple terminals.
3. It is necessary for the jumper and terminals to stabilize to the same temperature. They are stable in approximately 3 minutes.
4. Push **SHIFT** and **9** to zero the TC millivolt circuit.

**Thermocouple (TC) Source**

The Product can source all common thermocouple types in °F or °C, plus basic millivolts from -10.0 mV to 75.0 mV.

The following common thermocouple types are supported:

- B
- C
- E
- J
- K
- L
- N
- R
- S
- T
- U
- XK
- BP

1. Disconnect test leads from external devices.
2. Push **TC/RTD** to select thermocouple and RTD/Ω mode, if not already selected. If RTD/Ω mode is shown, push the key again to go to thermocouple mode.
3. If input mode is shown, push **SHIFT** and **7** to select output mode.
4. Push **TYPE UNITS** to select the necessary thermocouple type or the millivolt range.
5. Connect the UUT to the thermocouple terminals of the Product with a standard TC miniplug as shown in Figure 2-6. One pin is wider than the other. Do not push the plug into the incorrect polarization. The TC wire used for the connection must agree with the thermocouple type selected for correct cold junction compensation. It is necessary for the miniplug and terminals to become stable to the same temperature. They are stable in approximately 3 minutes.

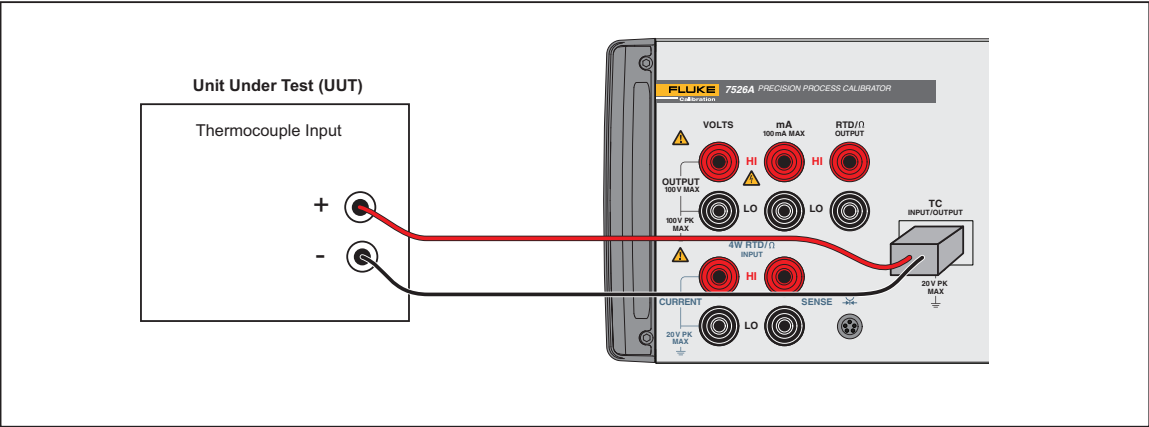

Figure 2-6. Thermocouple Output Connection

gwp015.eps

6. Push **SHIFT** and **6** to toggle the thermocouple display between °F and °C.
7. Push **SHIFT** and **5** to toggle the cold junction compensation between the internal temperature sensor and an external reference.
8. Use the numeric keypad to type the necessary output value and push **ENTER**.
9. As an alternative, use **▲** or **▼** to select a digit to change, followed by **▲** or **▼** to ramp the digit up or down. This method gives you a simple solution when small changes to an output value are necessary, or if it is necessary to increment or decrement decades.
10. For best accuracy, it is recommended to zero the TC millivolt circuit daily, or if the Product is used out of the ambient temperature range of 18 °C to 28 °C. This procedure is given in the “Thermocouple (T/C) Measure” section of this chapter.

## Pressure Measure

Many ranges and types of pressure modules are available from Fluke. The Product can use the Fluke Model 700 Series Modules. Before you use a pressure module, read its instruction sheet. Pressure modules vary in use, media, and accuracy.

1. Connect the pressure module to the Product as shown in Figure 2-7.

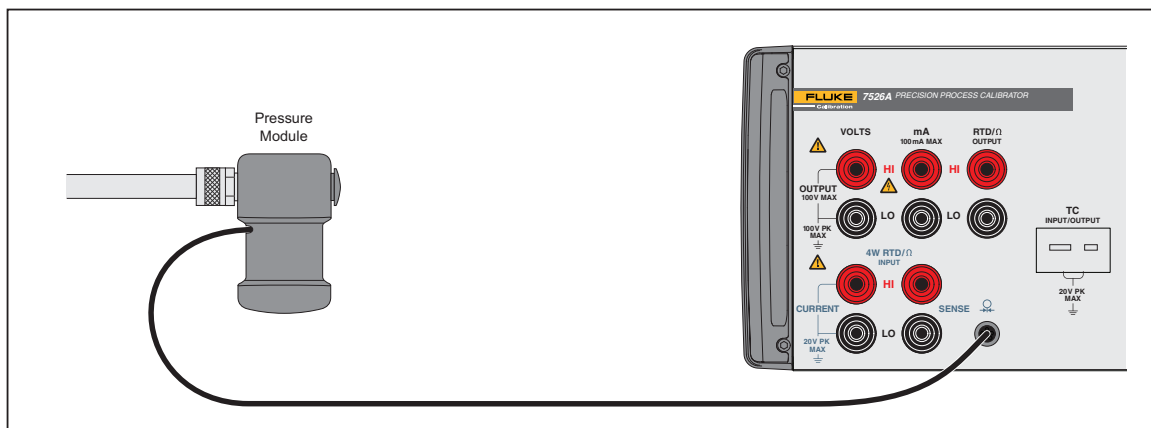

Figure 2-7. Pressure Module Connection

gwp016.eps

2. Push **Ω**. The Product automatically senses which pressure module is attached and sets its range accordingly.
3. Push **TYPE UNITS** to select the necessary pressure units to show.
4. Before you attach the module to the pressure source, zero the module as given in the instruction sheet that came with the module. Procedures can be different, but all use **SHIFT** and **9**.
5. Attach the module to the pressure source. Refer to the instruction sheet that came with the module. Follow all safety precautions when you do work with high pressures.

Pressure modules that can be used with the Product are listed in Tables 2-3 and 2-4.

**Table 2-3. Fluke 700 Series Pressure Modules**

<b>Fluke Model Number</b>	<b>Range</b>	<b>Type and Media</b>
Fluke-700P00	0 to 1 inH <sub>2</sub> O	differential, dry
Fluke-700P01	0 to 10 inH <sub>2</sub> O	differential, dry
Fluke-700P02	0 to 1 psi	differential, dry
Fluke-700P22	0 to 1 psi	differential, wet
Fluke-700P03	0 to 5 psi	differential, dry
Fluke-700P23	0 to 5 psi	differential, wet
Fluke-700P04	0 to 15 psi	differential, dry
Fluke-700P24	0 to 15 psi	differential, wet
Fluke-700P05	0 to 30 psi	gage, wet
Fluke-700P06	0 to 100 psi	gage, wet
Fluke-700P07	0 to 500 psi	gage, wet
Fluke-700P08	0 to 1,000 psi	gage, wet
Fluke-700P09	0 to 1,500 psi	gage, wet
Fluke-700P27	0 to 300 psi	gage, wet
Fluke-700P29	0 to 3,000 psi	gage, wet
Fluke-700P30	0 to 5,000 psi	gage, wet
Fluke-700P31	0 to 10,000 psi	gage, wet
Fluke-700PA3	0 to 5 psi	absolute, wet
Fluke-700PA4	0 to 15 psi	absolute, wet
Fluke-700PA5	0 to 30 psi	absolute, wet
Fluke-700PA6	0 to 100 psi	absolute, wet
Fluke-700PV3	0 to -5 psi	vacuum, dry
Fluke-700PV4	0 to -15 psi	vacuum, dry
Fluke-700PD2	±1 psi	dual range, dry
Fluke-700PD3	±5 psi	dual range, dry
Fluke-700PD4	±15 psi	dual range, dry
Fluke-700PD5	-15 / +30 psi	dual range, wet
Fluke-700PD6	-15 / +100 psi	dual range, wet
Fluke-700PD7	-15 / +200 psi	dual range, wet

**Table 2-4. Fluke 525A-P Series Pressure Modules**

<b>Fluke Model Number</b>	<b>Range</b>	<b>Type and Media</b>
Fluke-525A-P02	0 to 1 psi	differential, dry
Fluke-525A-P03	0 to 5 psi	gage, wet
Fluke-525A-P04	0 to 15 psi	gage, wet
Fluke-525A-P05	0 to 30 psi	gage, wet
Fluke-525A-P06	0 to 100 psi	gage, wet
Fluke-525A-P07	0 to 500 psi	gage, wet
Fluke-525A-P08	0 to 1000 psi	gage, wet
Fluke-525A-P29	0 to 3000 psi	gage, wet
Fluke-525A-PA4	0 to 15 psia	absolute, wet
Fluke-525A-PA5	0 to 30 psia	absolute, wet
Fluke-525A-PA6	0 to 100 psia	absolute, wet
Fluke-525A-PA7	0 to 500 psia	absolute, wet
Fluke-525A-PA8	0 to 1000 psia	absolute, wet
Fluke-525A-PV4	-15 to 0 psi	vacuum, dry



# **Chapter 3**

## ***Isolated Inputs***

<b>Title</b>	<b>Page</b>
Voltage Input .....	3-3
Current Input.....	3-3
Pressure Input .....	3-4
Switch Test .....	3-5
Output Setpoints .....	3-6



## Voltage Input

The Product can measure dc voltages from 0 V to 100 V. Use these ranges for maximum accuracy: 10 V and 100 V.

1. Disconnect test leads from external devices.
2. Push **VOLTS/mA SW TEST** to select isolated dc voltage and current input mode, if not already selected. If the necessary dc voltage mode is not shown, push **VOLTS/mA SW TEST** again to cycle to the necessary dc voltage mode.
3. Connect the unit under test (UUT) to the isolated voltage/current input terminals of the Product as in Figure 3-1.

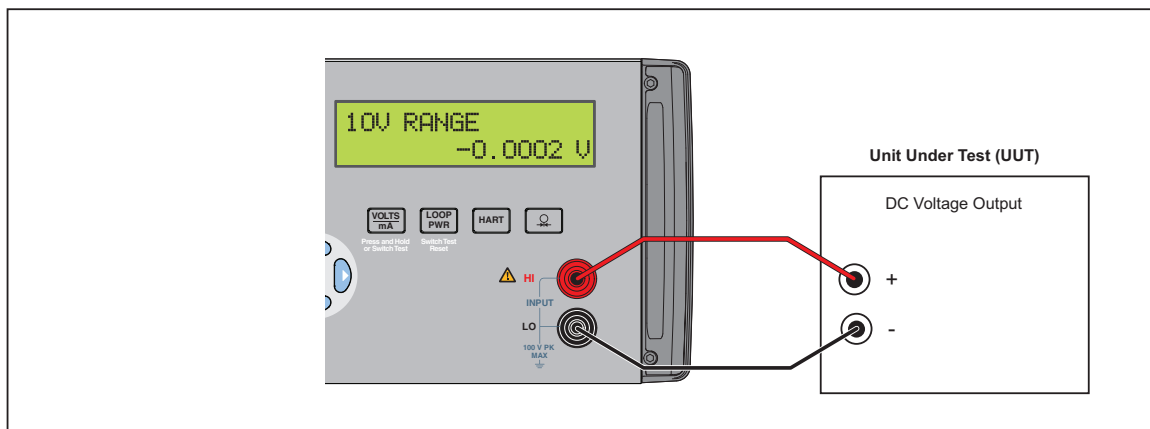

gwp017.eps

Figure 3-1. Isolated DC Voltage Input Connection

## Current Input

The Product can measure dc current from 0 mA to 50 mA.

1. Disconnect test leads from external devices.
2. Push **VOLTS/mA SW TEST** to select isolated dc voltage and current input mode, if not already selected. If the dc current mode is not shown, push the key again to go to it.
3. Connect the UUT to the isolated voltage/current input terminals of the Product as in Figure 3-2.

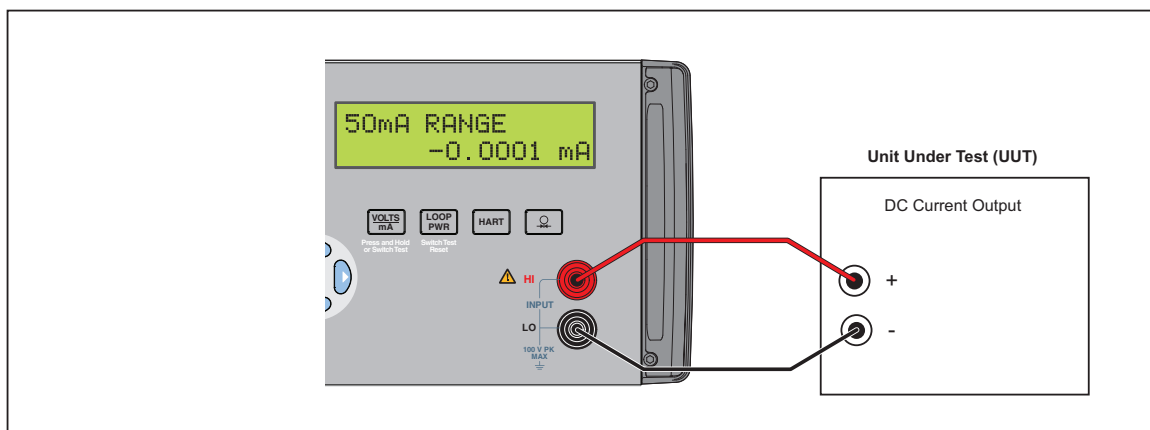

gwp018.eps

Figure 3-2. Isolated DC Current Input Connection

4. If the UUT is a 2-wire loop powered transmitter that is disconnected from the wiring,

push **LOOP PWR** to turn on the Product internal 24 V supply in series with the current measuring circuit. The top line changes to 24mA LPWR to show that the supply is on. Push **LOOP PWR** again to turn off the supply and the top line reverts to 50mA RANGE.

5. If a 250  $\Omega$  resistor is necessary during a HART calibration procedure, push **HART** to switch in the Product internal 250  $\Omega$  resistor. HART is added to the top line of the display to show that the resistor is turned on in the circuit. Push **HART** again to turn off the resistor and the display changes to its previous condition. This resistor lowers the maximum-load driving function from 1000  $\Omega$  at 20 mA to 750  $\Omega$  at 20 mA.

## Pressure Input

The isolated pressure display uses the same physical pressure connector as the primary display. It is possible to have the displays set to show pressure at the same time. The same source can be shown in different pressure units. See the “Pressure Measure” in Chapter 2 for a discussion on pressure module selection.

1. Connect the pressure module to the Product as shown in Figure 3-3.

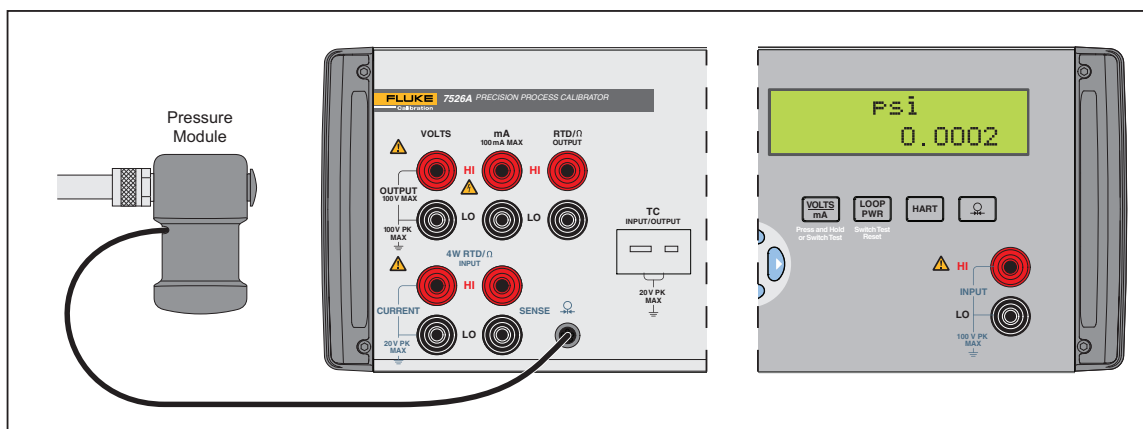

Figure 3-3. Isolated Pressure Module Connection

gwp019.eps

2. Push **Ω**. The Product automatically senses which pressure module is connected and sets its range accordingly.
3. If necessary, push **Ω** again to cycle through the pressure units until the necessary unit is shown.
4. Before you attach the module to the pressure source, zero the module as given in the instruction sheet that came with the module. Procedures can be different, but all end with **SHIFT** and **9**.
5. Attach the module to the pressure source. Refer to the instruction sheet that came with the module, and make sure to follow all safety precautions when dealing with high pressures.

## Switch Test

When in Switch Test mode the Calibrator can sense a contact transition (closed or opened). At the time of the transition the Calibrator records the value and units shown on the primary display. This means that a switch test can be done in all modes, read or source. After two transitions the Calibrator changes to recall mode. In recall mode, the value of the first transition, second transition, and the calculated deadband of the switch can be seen on the display. See Figure 3-4 for connections.

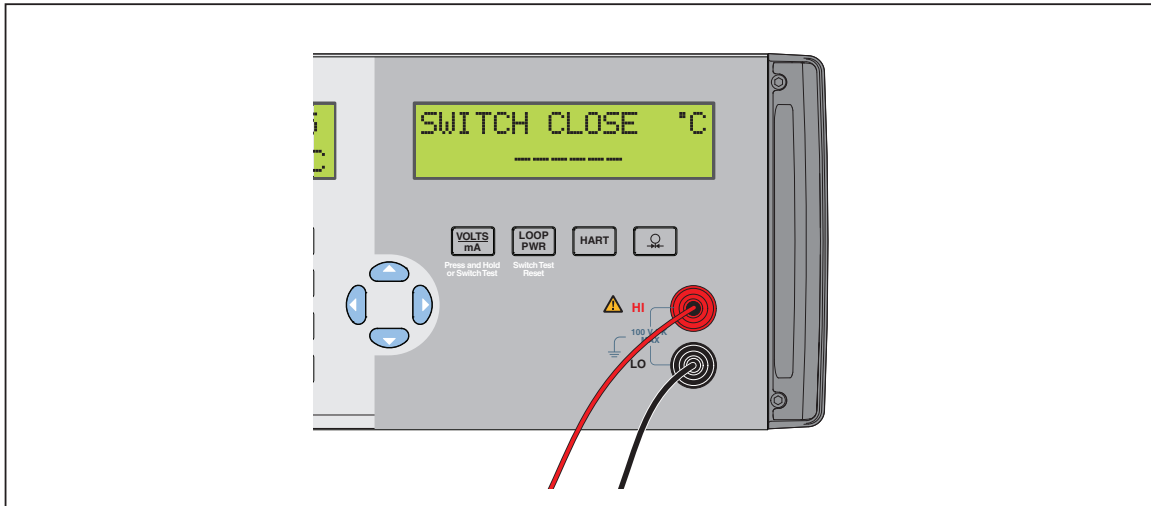



Figure 3-4. Switch Test and Pressure Module Connections

gwp070.eps

1. To go to switch test mode, push and hold  for three seconds.

When in switch test mode, the Calibrator shows the status of the switch contacts, in this instance, you can see the contact status of a normally open temperature switch:

SWITCHTEST OPEN  
----- °C

gwp036.eps

At the first transition, the switch contact closes:

SWITCHTEST CLOSE  
----- °C

gwp037.eps

After the second contact transition, the switch opens. After the second contact transition, the Calibrator enters the recall mode:



SWITCH CLOSED AT  
100.0 °C

gwp035.eps

2. Push .



SWITCH OPEN AT  
105.0 °C



gwp038.eps

3. Push .



SWITCH DEADBAND  
5.0 °C

gwp039.eps

When necessary, push  to reset the switch test. Hold down  for 3 seconds to put the Calibrator into the isolated input mode that was selected before.



## Output Setpoints

Nine preset output setpoints can be stored and recalled for each of these output modes:

- Voltage
- Current
- Each thermocouple type, this includes millivolts
- Each RTD type, this includes each of the five custom curves

They can be recalled on an individual basis or as an automatic up and down cycle with a configurable dwell time between each setpoint. The automatic cycle feature starts at setpoint number 1 and steps to a user-specified end setpoint number. It then goes back down in reverse sequence and cycles through the sequence again.

To set a setpoint:

1. Select the output mode.
2. Type the output value for the setpoint.
3. Push  and  to select the SET function.
4. At the setpoint number selection prompt "SET POINT#", push the numeric key, 1 to 9, for the setpoint to be set.
5. If the automatic cycle feature is to be used, make sure to correctly sequence the setpoint values. It always cycles between setpoint number 1 and a user-specified end setpoint number. The values in the cycled group of setpoints must be keyed in with this in mind. Random setpoints used for individual checks can then be found after the usual end setpoint number.

To recall a setpoint:

1. Select the output mode.
2. Push **SHIFT** and **2** to select the RECALL function.
3. At the setpoint number selection prompt "RECALL SPT#", push the numeric key, 1 to 9, for the setpoint to be recalled.

To start an automatic setpoint cycle:

1. Select the output mode.
2. Push **SHIFT** and **3** to select the AUTOSSET function.
3. At the end setpoint number selection prompt "AUTO SET POINT", push the numeric key, 1 to 9, for the end setpoint number for the cycle.
4. At the dwell time prompt "DWELL TIME", "5-500?", record the number of seconds, 5 to 500, to dwell at each setpoint value, followed by **ENTER**.
5. **STBY OPR** can be used at any time during the cycle without stopping it.
6. Push the other Product keys to stop the cycle.





# **Chapter 4**

## **Application Notes**

<b>Title</b>	<b>Page</b>
Introduction.....	4-3
P/I Transmitter .....	4-3
I/P Transmitter .....	4-4
V/I Transmitter .....	4-5
RTD Test.....	4-6
RTD Transmitter.....	4-7
Thermocouple Test .....	4-8
Thermocouple Transmitter.....	4-9
RTD Indicator.....	4-10
Precision Current Trip .....	4-11
I/I Isolator/Transmitter .....	4-12
Precision Temperature Measurement with Probe.....	4-13
Temperature Switch Test.....	4-14
Pressure Switch Test.....	4-16



## Introduction

This chapter includes application notes that will help you to understand how to better use the Product under different situations.

## P/I Transmitter

1. Disconnect test leads from external devices.
2. Select pressure input on the primary display as given in the “Pressure Measure” section of Chapter 4.
3. Select current input on the isolated display as given in the “Current Input” section of Chapter 5. Select isolated loop power. If a HART communicator is used for set up of the transmitter, select HART.
4. Connect the transmitter as shown in Figure 4-1.
5. To verify and calibrate the transmitter, refer to the transmitter documentation.

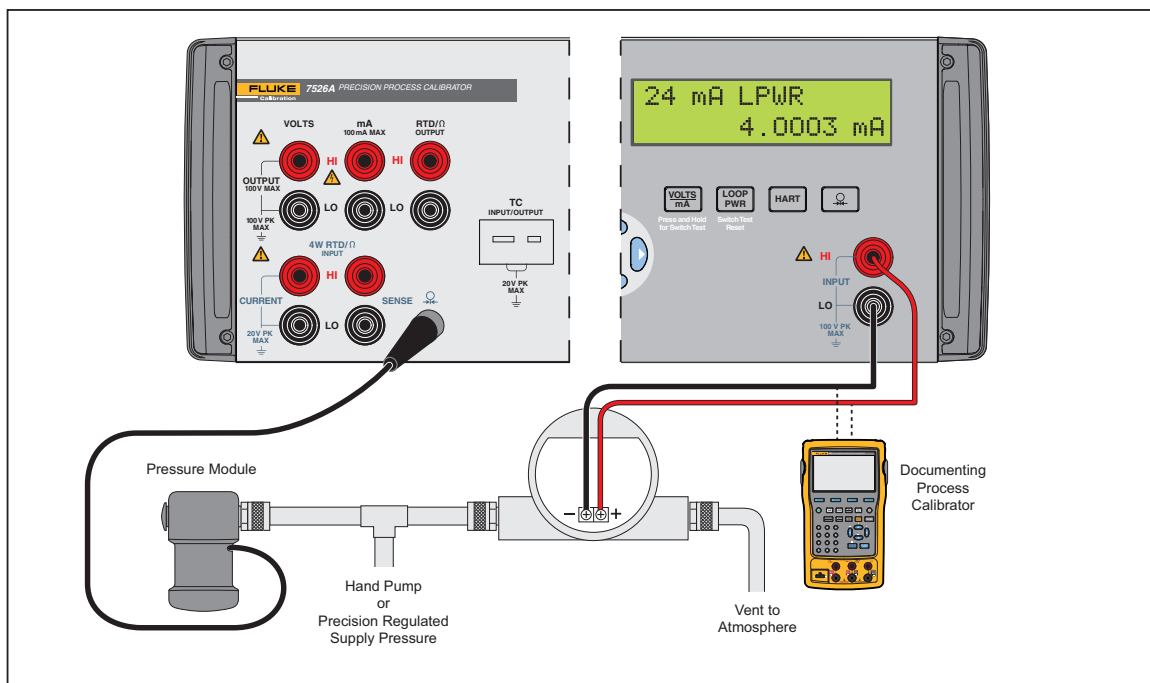

gwp020.eps

Figure 4-1. P/I Transmitter Application

## I/P Transmitter

1. Disconnect test leads from external devices.
2. Select current output on the primary display as given in the “DC Current Output” section of Chapter 4.
3. Select pressure input on the isolated display as given in the “Pressure Input” section of Chapter 5.
4. Connect the transmitter as shown in Figure 4-2.
5. To verify and calibrate the transmitter, refer to the transmitter documentation.

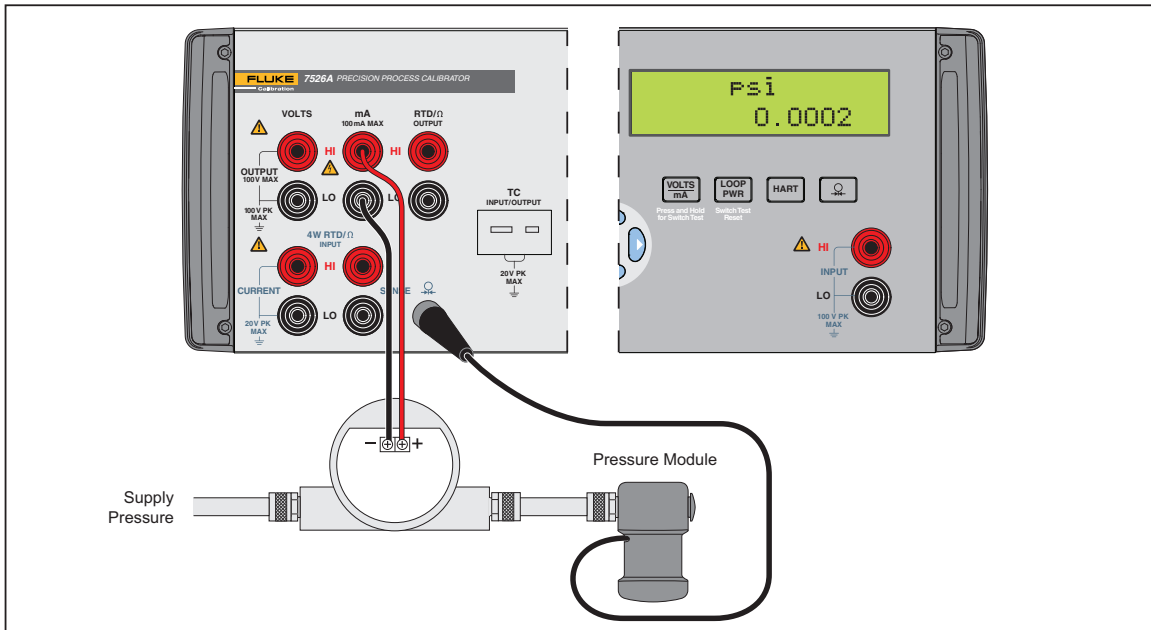

Figure 4-2. I/P Transmitter Application

gwp021.eps

## V/I Transmitter

1. Disconnect test leads from external devices.
2. Select voltage output on the primary display as given in the “DC Voltage Output” section of Chapter 4.
3. Select current input on the isolated display as given in the “Current Input” section of Chapter 5. Select the isolated loop power option.
4. Connect the transmitter as shown in Figure 4-3.
5. To verify and calibrate the transmitter, refer to the transmitter documentation.

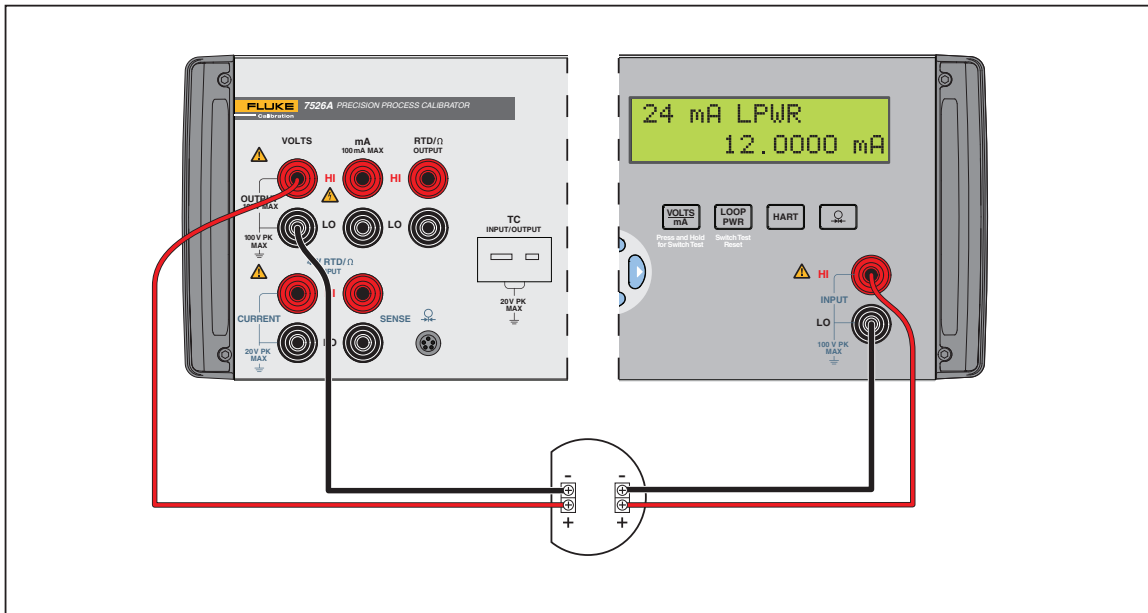

Figure 4-3. V/I Transmitter Application

gwp022.eps

## RTD Test

1. Disconnect test leads from external devices.
2. Select RTD input on the primary display as given in the “Resistance Temperature Detector (RTD) and Ohms Measure” section of Chapter 4.
3. Select the correct RTD type.
4. Connect the RTD as shown in Figure 4-4.
5. To verify the RTD, refer to the RTD documentation.

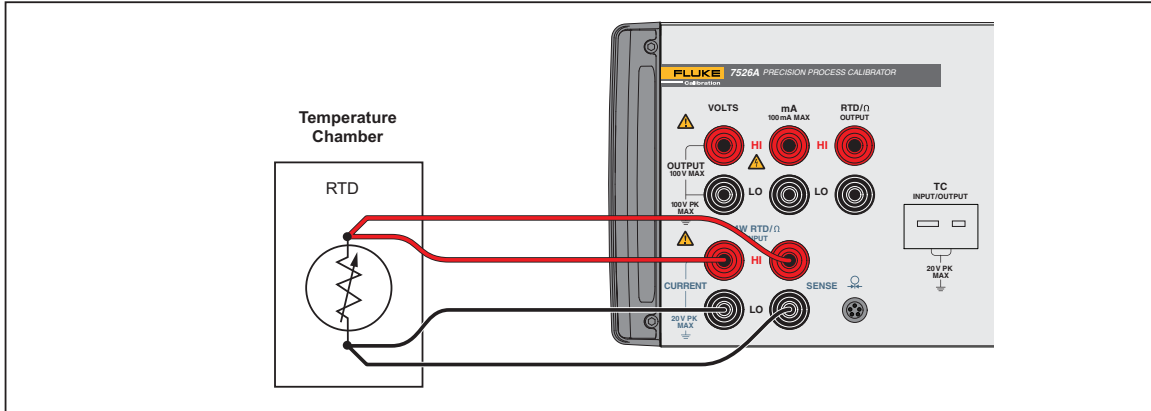

Figure 4-4. RTD Test Application

gwp023.eps

## RTD Transmitter

1. Disconnect test leads from external devices.
2. Select RTD output on the primary display as given in the “Resistance Temperature Detector (RTD) and Ohms Source” section of Chapter 4.
3. Select the correct RTD type.
4. Select current input on the isolated display as given in the “Current Input” section in Chapter 5.
5. Select the isolated loop power option. If a HART communicator will be used for setup of the transmitter, select HART.
6. Connect the transmitter as shown in Figure 4-5.
7. To verify and calibrate the transmitter, refer to the transmitter documentation.

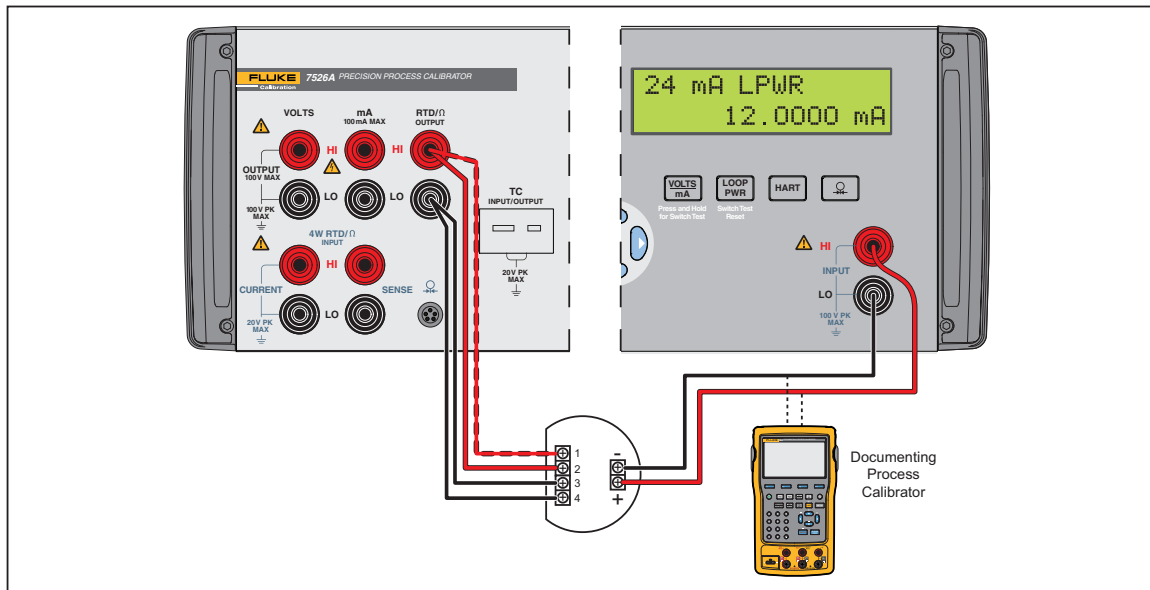

Figure 4-5. RTD Transmitter Application

gwp024.eps

## Thermocouple Test

1. Disconnect test leads from external devices.
2. Select thermocouple input on the primary display as given in the “Thermocouple (TC) Measure” section in Chapter 4.
3. Select the correct thermocouple type.
4. Connect the thermocouple as shown in Figure 4-6.
5. To verify the thermocouple, refer to the thermocouple documentation.

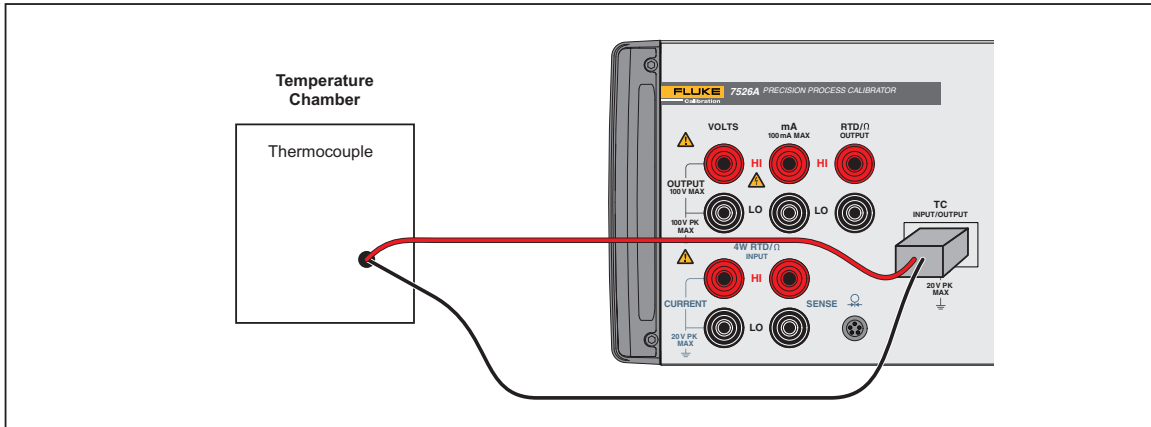

Figure 4-6. Thermocouple Test Application

gwp025.eps



## Thermocouple Transmitter

1. Disconnect test leads from external devices.
2. Select thermocouple output on the primary display as given in the “Thermocouple (TC) Source” section of Chapter 4.
3. Select the correct thermocouple type for the transmitter.
4. Select current input on the isolated display as given in the “Current Input” section of Chapter 5.
5. Select the isolated loop power option. If a HART communicator is necessary for set up of the transmitter, select HART.
6. Connect the transmitter as shown in Figure 4-7.
7. To verify and calibrate the transmitter, refer to the transmitter documentation.

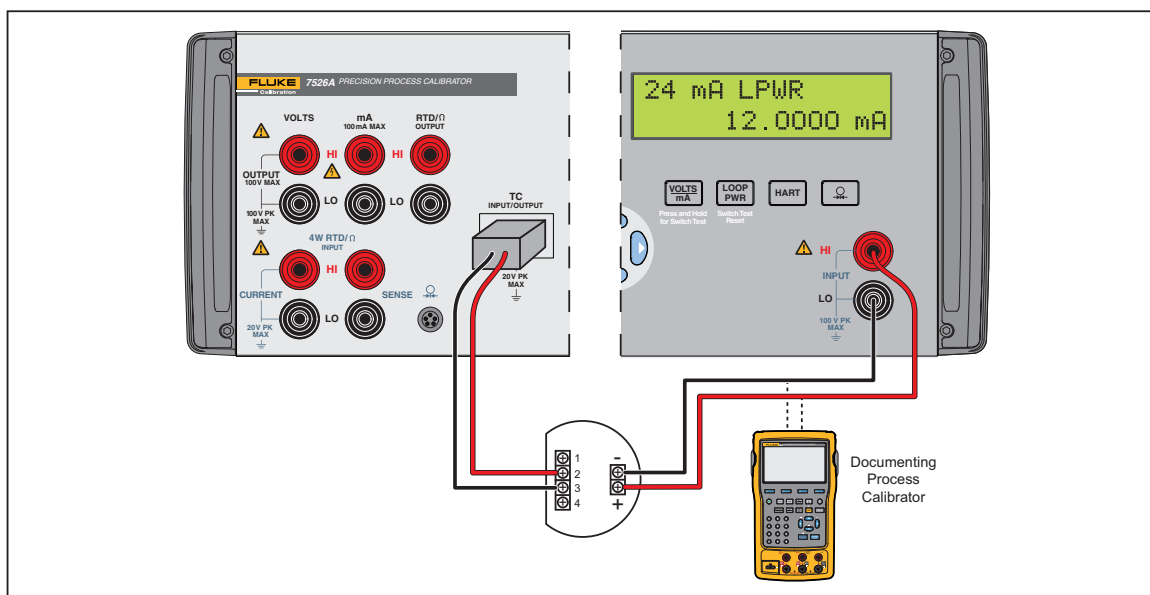

gwp026.eps

Figure 4-7. Thermocouple Transmitter Application

### RTD Indicator

1. Disconnect test leads from external devices.
2. Select RTD output on the primary display as given in the “Resistance Temperature Detector (RTD) and Ohms Source” section of Chapter 4.
3. Select the correct RTD type for the indicator.
4. Connect the indicator as shown in Figure 4-8.
5. To verify and calibrate the indicator, refer to the indicator documentation.

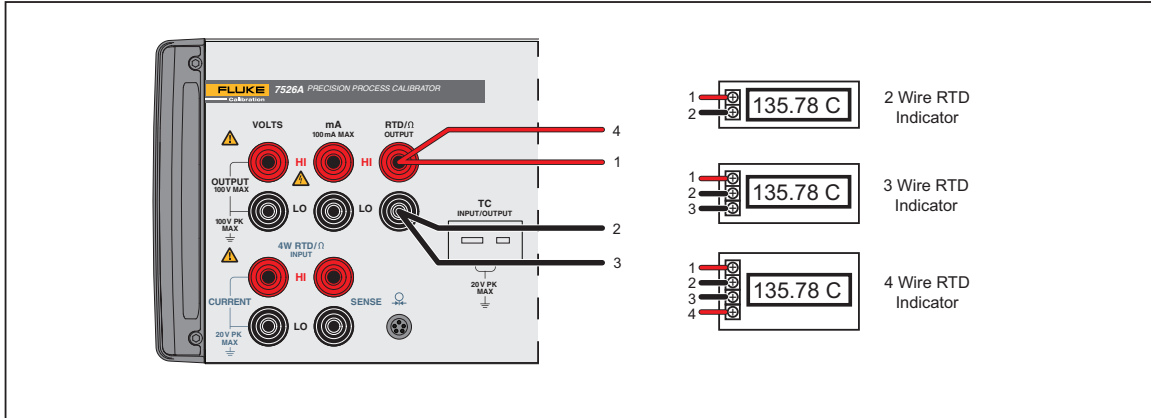
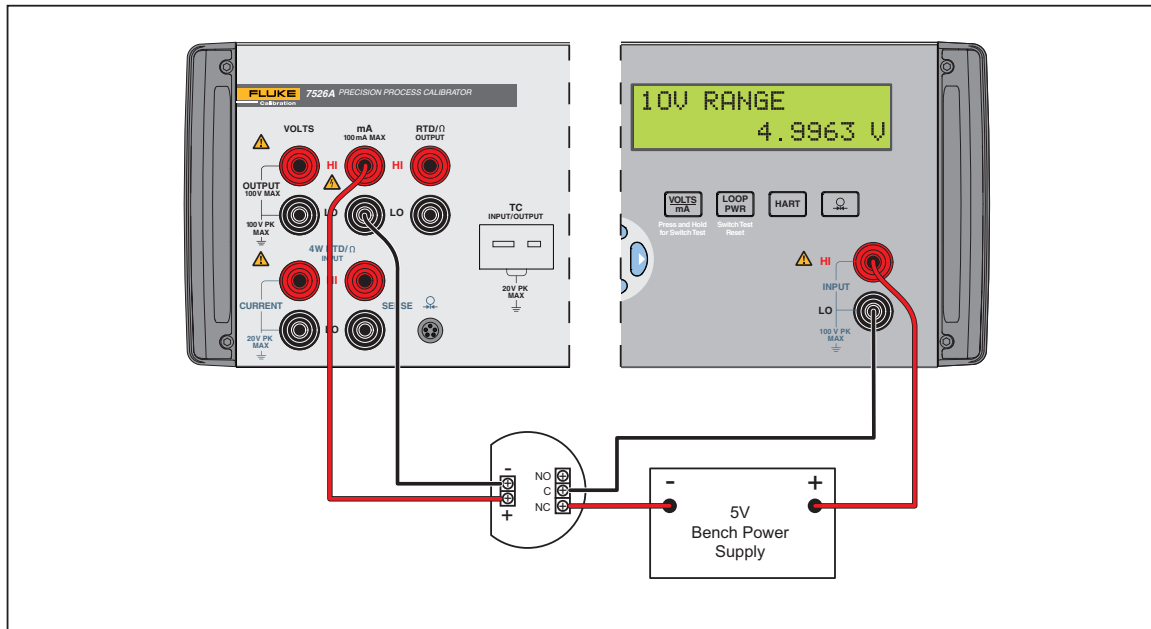

Figure 4-8. RTD Indicator Application

gwp027.eps

### Precision Current Trip

1. Disconnect test leads from external devices.
2. Select current output on the primary display as given in the “DC Current Output” section of Chapter 4.
3. Select voltage input on the isolated display as given in the “Voltage Input” section in Chapter 5.
4. Connect the trip as shown in Figure 4-9.
5. To verify and calibrate the trip, refer to the trip documentation.



gwp028.eps

Figure 4-9. Precision Current Trip Application

### I/I Isolator/Transmitter

1. Disconnect test leads from external devices.
2. Select current output on the primary display as given in the “DC Current Output” section of Chapter 4.
3. Select current input on the isolated display as given in the “Current Input” section of Chapter 5.
4. Select the isolated loop power option.
5. Connect the transmitter as shown in Figure 4-10.
6. To verify and calibrate the transmitter, refer to the transmitter documentation.

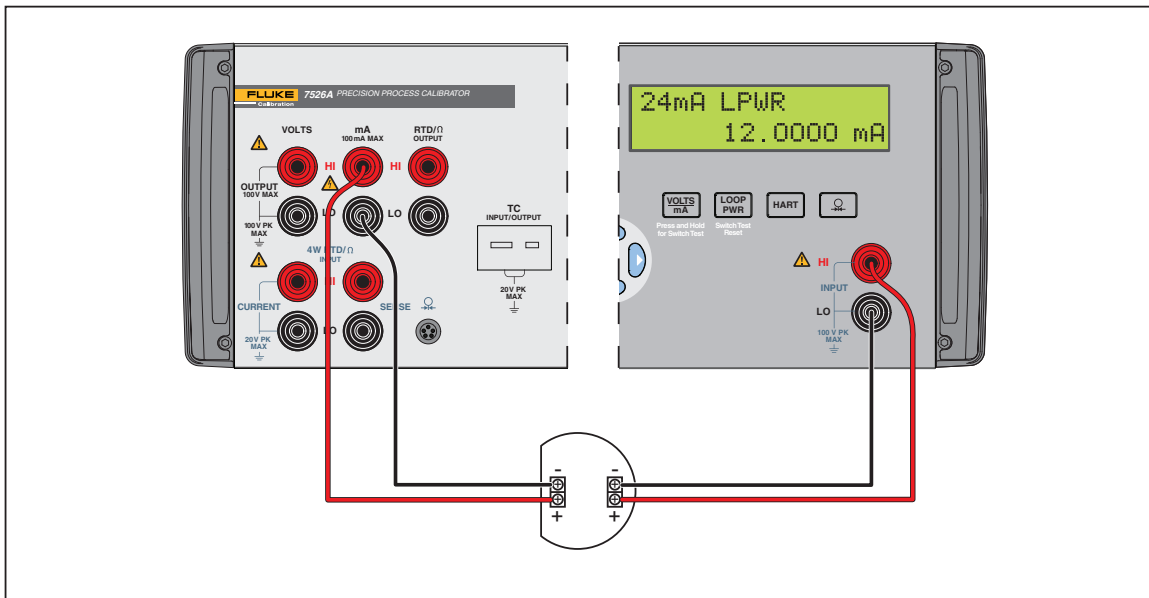

gwp029.eps

Figure 4-10. I/I Isolator/Transmitter Application

### Precision Temperature Measurement with Probe

1. With the probe and the custom coefficients that go with the probe, the total system error is 0.03 °C.
2. Disconnect test leads from external devices.
3. Select RTD input on the primary given as given in the “Resistance Temperature Detector (RTD) and Ohms Measure” section of Chapter 4.
4. Select the user-defined curve with the custom coefficients for the probe. If custom coefficients have not been recorded for the probe, follow the instructions in the “Resistance Temperature Detector (RTD) with Custom Coefficients” section in Chapter 4.
5. Connect the probe as shown in Figure 4-11.

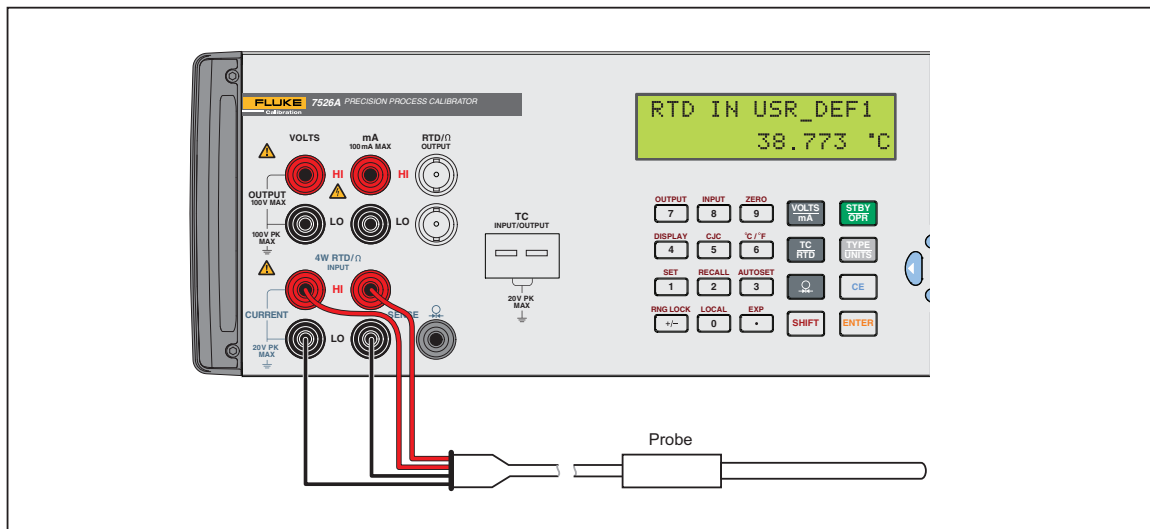

Figure 4-11. Precision Temperature Measurement with Probe

gwp030.eps

### Temperature Switch Test

To do a temperature switch test, see Figure 4-12 for the necessary connections and do the subsequent steps.

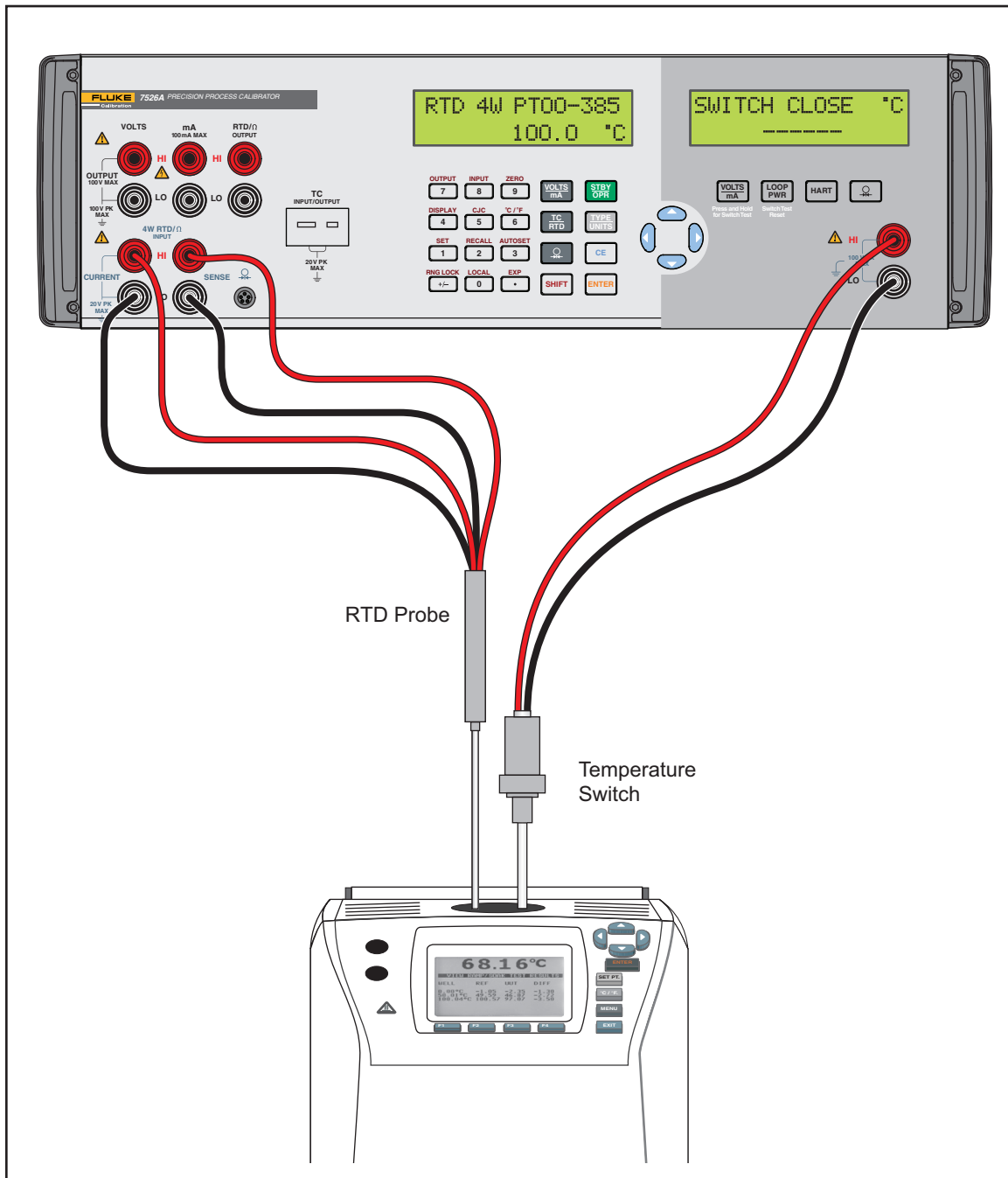

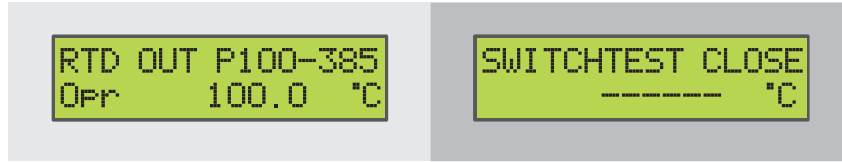

Figure 4-12. Temperature Switch Test Connections

gwp054.eps

1. To go to the switch test mode, push and hold  for three seconds.
2. Connect the Calibrator to the switch with the isolated terminals. The polarity of the terminals is not important.
3. The top of the isolated display will read “CLOSE”:



gwp060.eps

4. Increase the temperature slowly until the switch opens.
5. When the switch opens, “OPEN” will be shown. Decrease the temperature slowly until the switch closes:

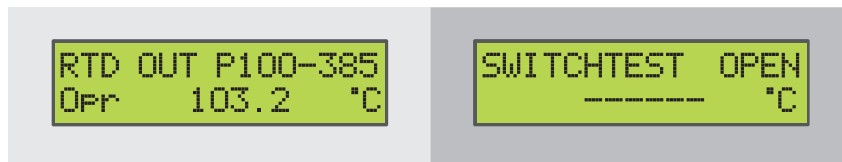

gwp061.eps

6. At the top of the isolated display it will now read, “SW OPENED AT” and show the temperature that the switch opened at:



gwp062.eps

7. Push  to see when the switch closed and the deadband:



gwp063.eps



gwp064.eps

8. Push  to get to the main menu. Clear the data and do another test.

Note

The last example uses a normally closed switch. The basic procedure is the same for a normally open switch, but the display will read "OPEN" as an alternative to "CLOSE".

**Pressure Switch Test**

The connections for this test are shown in Figure 4-13.

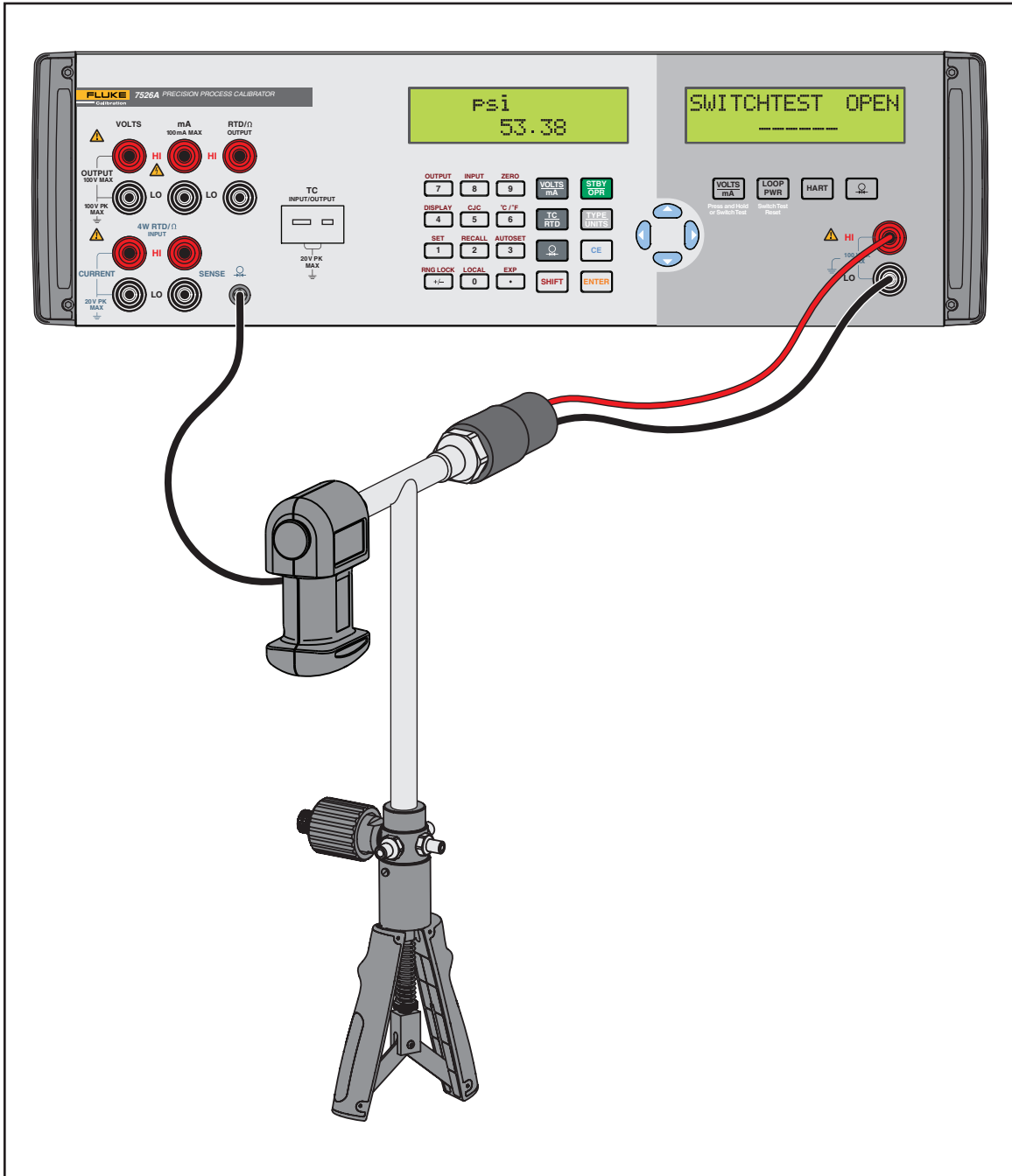



Figure 4-13. Pressure Switch Test Connections

gwp034.eps



To do the pressure switch test:

1. To go to the switch test mode, push and hold  for 3 seconds.
2. Connect the Calibrator to the switch. Use the isolated terminals. The polarity of the terminals is not important.
3. Connect the pump to the Calibrator and the pressure switch. Make sure the vent on the pump is open.
4. Zero the Calibrator if necessary.
5. Close the vent after you zero the Calibrator.
6. The top of the isolated display will read “CLOSE”.



gwp065.eps

7. Apply pressure with the pump slowly until the switch opens.

*Note*

*When you pressurize the device under test, it must be done slowly to make sure the readings will be accurate.*

8. When the switch is open, “OPEN” will be shown. Bleed the pump slowly until the pressure switch closes.



gwp066.eps

9. The top of the isolated display will now read, “SW OPENED AT” and show at what pressure that the switch opened.



gwp067.eps

10. Push the “NEXT” option to see when the switch closed, and the deadband.

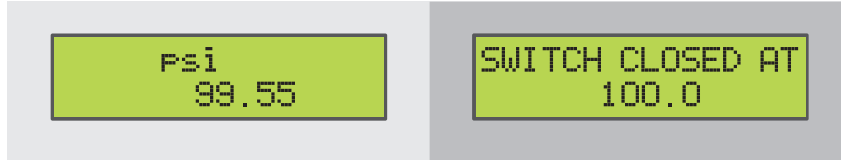

wp068.eps

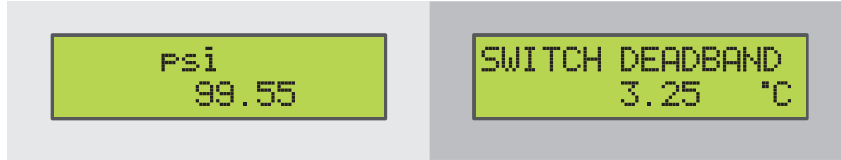

gwp069.eps

*Note*

*The previous example uses a normally closed switch.*

*The basic procedure is the same for a normally open switch but the display will show “OPEN” as an alternative to “CLOSE”.*

# **Chapter 5**

## ***LCD and Remote Interface Setup Procedures***

<b>Title</b>	<b>Page</b>
Introduction.....	5-3
Access LCD and Remote Interface Setup Procedures .....	5-3
Remote Interface.....	5-3
Set Up the RS-232 Port for Remote Control .....	5-4
Use with Computer USB Ports.....	5-5
Set Up the IEEE-488 Port for Remote Control .....	5-5
Change Between Local and Remote Operation.....	5-6
IEEE-488 Interface Overview.....	5-7
Command Use.....	5-8
Command Syntax .....	5-10
Check Product Status.....	5-13



## Introduction

This chapter tells you how to set up and use the Remote Interface. It also explains the IEEE-488 interface and gives a listing of remote commands and their functions.

## Access LCD and Remote Interface Setup Procedures

To access LCD and Remote Interface setup procedures:

1. Push **SHIFT** and **4** to select the SETUP function.
2. At the "LCD CONTRAST" prompt, push **▲** or **▼** to adjust the LCD contrast.
3. Push **ENTER**.
4. At the "LCD BACKLIGHT" prompt, push **▲** or **▼** to adjust the LCD backlight.
5. Push **ENTER**.
6. At the "Remote Interface" prompt, push **▲** or **▼** to select the RS-232 interface or the GPIB interface. When the necessary interface is selected, push **ENTER**.
7. If the GPIB interface is selected, the "GPIB Address" prompt is shown. Push **▲** or **▼** to cycle through the possible addresses, 0 to 30. When the necessary address is shown, push **ENTER**.

## Remote Interface

The Product can be controlled remotely from a personal computer (PC). Use an RS-232 serial connection or an IEEE-488 parallel connection (also called a General Purpose Interface Bus, or GPIB connection). Individual commands can be typed into terminal emulator software applicable for the connection type. The Calibrator can also be controlled by PC software that uses the Product command set. You can write your own PC program or purchase applicable third-party software and configure it for the Product. MET/CAL, a compatible software for IEEE-488 operation, can be purchased from Fluke.

The RS-232 connection lets one Product be connected to one PC. The communication speed is slower than IEEE-488, but no other equipment is necessary other than a low-cost null modem cable.

The IEEE-488 connection lets you connect a maximum of 15 different calibrators, PCs, and items of test equipment together in a bus system. The communication speed is much faster than RS-232, but it is necessary to purchase and install special PC interface card(s) and cable(s).

This section gives the setup of the two types of connections, and the general operation of the command set. Chapter 6 gives the individual commands.

### Set Up the RS-232 Port for Remote Control

The Product is programmable with a standard RS-232 connection with a PC. The RS-232 cable for the port must be shorter than 15 meters (50 feet). Longer cables are permitted if the load capacitance measured at a connection point (including signal terminator) is not larger than 2500 pF.

The serial communications parameters in the Product are set at these values:

- 9600 baud
- 8 data bits
- 1 stop bit
- no parity
- Xon/Xoff
- EOL (end-of-line) character CR (Carriage Return)

A typical RS-232 connection is shown in Figure 5-1. Note that a null modem cable is used for the connection. See the “Rear Panel” section in Chapter 1 for the location of the RS-232 port on the rear panel of the Product.

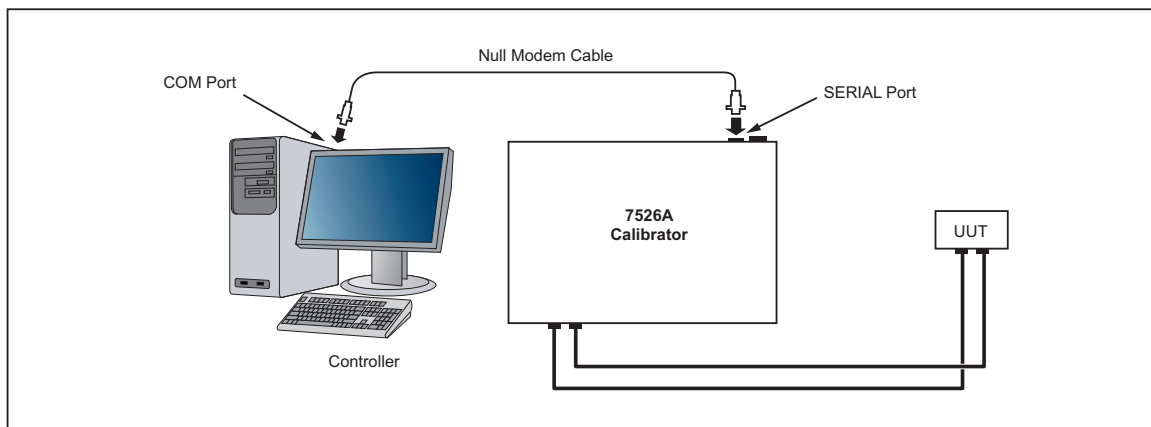

Figure 5-1. RS-232 Remote Connection

gwp031.eps

### Use with Computer USB Ports

The Product can be used with a computer USB ports with a USB to serial converter. Fluke can supply the equipment for this connection:

- 80313, Cable, USB to serial adapter
- 80157, Cable, Null modem, RS-232

See Figure 5-2 for connections.

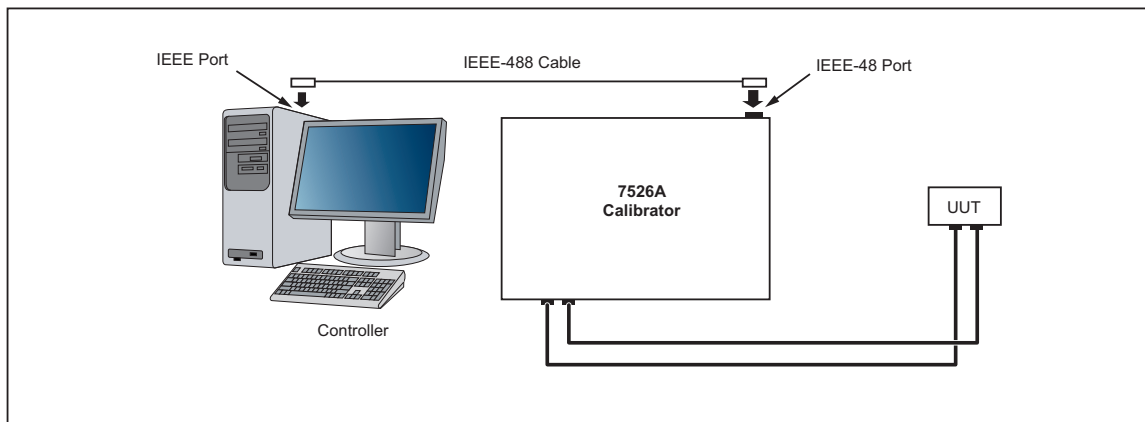

Figure 5-2. RS-232 Remote Connection

gwp032.eps

### Set Up the IEEE-488 Port for Remote Control

The Product is fully programmable for you to use on a standard IEEE-488 interface bus. The IEEE-488 interface is also in compliance with supplemental standard IEEE-488.2, which gives you more IEEE-488 features. Devices connected to the IEEE-488 bus are designated as talkers, listeners, talker/listeners, or controllers. The Product operates as a talker/listener when you use it by remote control from an instrument.

A PC with an IEEE-488 interface controls the Product. Compatible software for IEEE-488 operation, MET/CAL, can be purchased from Fluke Calibration.

When you use the IEEE-488 remote control interface, there are two restrictions:

1. A maximum of 15 devices can be connected in one IEEE-488 bus system.
2. The total length of IEEE-488 cables used in one IEEE-488 bus system is the smaller of 2 meters multiplied by the number of devices in the system or 20 meters (65 feet).

See Chapter 5 for instructions to configure the Product for IEEE-488 (GPIB) operation. These instructions include interface and bus address selection. A typical IEEE-488 (GPIB) connection is shown in Figure 5-3. See the "Rear Panel" section of Chapter 1 for the location of the IEEE-488 (GPIB) port on the rear panel of the Product.

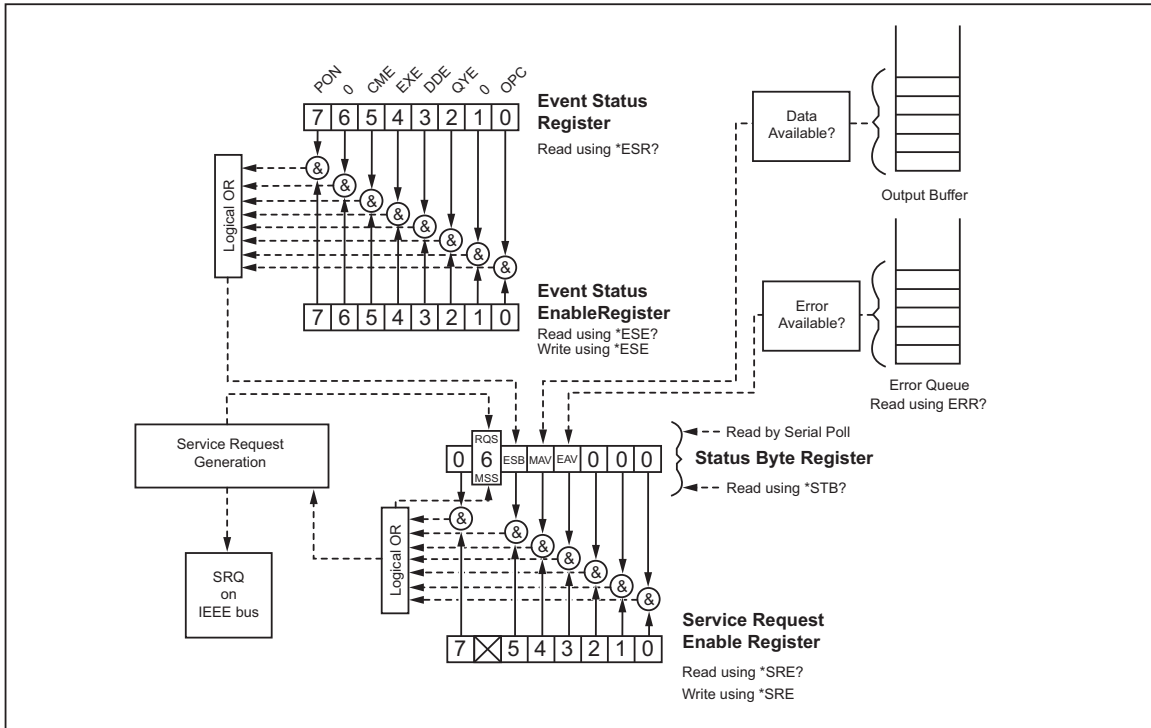

Figure 5-3. IEEE-488 (GPIB) Remote Connection

gwp033.eps

### Change Between Local and Remote Operation

With local mode (front-panel operation) and remote, the Product can be put into a local lockout condition by command of the controller. Mixed, the local, remote, and lockout conditions will give you four possible operation conditions as follows.

#### 1. Local State

The Product answers to local and remote commands. This is usual front-panel operation. All remote commands received by the Product are processed.

#### 2. Local with Lockout State

Local with lockout is the same to local, but the Product will go into the remote with lockout state as an alternative to the remote state when it receives a remote command. You can only go to this state with the IEEE-488 command GTL (Go To Local) when in the remote with lockout state.

#### 3. Remote State

When the Product is put in remote, by RS-232 REMOTE command, or by IEEE-488 asserting the REN line, it goes to the remote state. The left-end of the top-line of the display changes to: rem.

Front-panel operation is stopped. This does not include the LOCAL (0) key. Push the LOCAL key, use RS-232 to send the LOCAL command, or use IEEE-488 to send the GTL (Go To Local) message. The Product goes to the local state.

#### 4. Remote with Lockout State

When the Product is in lockout, by RS-232 LOCKOUT command, or by IEEE-488 message LLO (Local Lockout), the Product front-panel controls are locked out. The left-end of the top-line of the display changes to: rem.

To change the Product to the local with lockout state, send the RS-232 LOCAL command or the IEEE-488 GTL (Go To Local) message.



Table 5-1 gives the possible operation state transitions. For more information about IEEE-488 GPIB messages, see the “IEEE-488 Interface Overview” section of this chapter.

**Table 5-1. Operating State Transitions**

From	To	Front Panel	GPIB Message	Serial Command
Local	Remote Local with Lockout		MLA (REN True) LLO	REMOTE LOCKOUT
Remote	Local Remote with Lockout	Local 0 key	GTL or REN False LLO	LOCAL LOCKOUT
Local with Lockout	Local Remote with Lockout		REN False MLA (REN True)	LOCAL REMOTE
Remote with Lockout	Local Local with Lockout		REN False GTL	LOCAL

## IEEE-488 Interface Overview

The IEEE-488 parallel interface sends commands as data and receives measurements and messages as data. The maximum data exchange rate is 1 Mbyte per second, with a maximum distance of 20 meters for the full length of the cable connections. One cable must not be more than 4 meters.

Some commands are used only for RS-232 serial operation because these functions must be implemented as IEEE uniline (single control line) bus management messages per the IEEE Standards. For example, the command REMOTE can be sent as data over the IEEE-488 interface to put the Product into remote operation mode, but it is not because the IEEE Standards use the remote function to be sent to the device as the uniline message REN. This is also true for some other commands and functions, as shown in Table 5-2 with their RS-232 equivalents.

**Table 5-2. RS-232 Emulation of IEEE-488 Messages**

IEEE-488 Message	RS-232 Equivalent
GTL	LOCAL command
GTR	REMOTE command
LLO	LOCKOUT command
SDC, DCL	(not emulated on RS-232)
GET	(not emulated on RS-232)
SPE, SPD	(not emulated on RS-232)
UNL, UNT	(not emulated on RS-232)

The IEEE-488 interface uses the IEEE Standards 488.1 and 488.2 as its basis. For more information, refer to the IEEE-488.1 and IEEE-488.2 standards.

## Command Use

Communications between the controller and the Product use commands, queries, and interface messages. Although the commands use the 488.2 standard as their basis, they can be used on the IEEE-488 or RS-232 interface. There are some special RS-232 only commands as shown in the section “Commands for RS-232 Only”.

For more information on IEEE command structures, see the IEEE 488.2 standard.

See Chapter 6 for more information about the commands referenced in this section.

All commands, units, and text data can be recorded in UPPER or lower-case letters. The Product changes all lower-case letters to upper case before they are used.

## Types of Commands

The commands for the Product can be put into these categories:

### Device-Dependent Commands

Device-dependent commands are unique to the Product. An example of a device-dependent command is:

OUT 1 V

This command tells the Product to source 1 V dc

### 1. Common Commands

Common commands are specified by the IEEE 488.2 standard and are common to most bus devices. Common commands start with an asterisk (\*). Common commands are available if you use the IEEE-488 or RS-232 interface for remote control. An example of a common command is:

\*IDN?

This command tells the Product to show the instrument identification string.

### 2. Query Commands

Query commands requests for information, which can be shown as the command operates, or can be put in a buffer until it is necessary later. Query commands end with a question mark. An example of a query commands is:

RANGE?

This command tells the Product to show the current DC voltage output range.

### 3. Interface Messages (IEEE-488)

Interface messages control traffic on the IEEE-488 interface bus. Device addressing and clearing, data handshaking, and commands to put status bytes on the bus are all directed by interface messages. Some of the interface messages occur as state transitions of dedicated control lines. The remaining interface messages are sent through the data lines with the ATN signal true. All device-dependent and common commands are sent through the data lines with the ATN signal false.

An important thing about interface messages is that, unlike device-dependent and common commands, interface messages are not sent literally in a direct method. They are changed to parallel signal levels on the bus data and control lines.

IEEE-488 standards define interface messages which are managed automatically in most cases.

#### 4. Compound Commands

A compound command is two or more commands put on one command line isolated from each other with semicolons. For example, the subsequent two individual commands:

```
OUT 1 V OPER
```

can be mixed into the compound command: `OUT 1 V; OPER`

These commands tell the Product to source 1 V dc, and then go into operate mode.

#### 5. Overlapped Commands

Commands that start execution but take more time than the usual communication command/response interval to complete are overlapped commands. This is because they can be overlapped by receipt the command that follows before they are complete.

The detailed command descriptions in Chapter 6 show a check mark by Overlapped for overlapped commands.

Use the command `*WAI` to stop until the overlapped command is complete before you do the command that follows. For example:

```
OUT 1 V; *WAI
```

You can also use the status commands `*OPC` and `*OPC?` to find the overlapped commands that are complete.

#### 6. Sequential Commands

Commands that operate immediately are sequential commands.

The command descriptions in Chapter 6 show a check mark by Sequential for sequential commands.

Most commands are sequential.

#### 7. Commands for RS-232 Only

Some commands are used only for RS-232 serial operation because these functions must be done as IEEE uniline (single control line) bus management messages per the IEEE Standards. For example, the command `REMOTE` can be sent as data through the IEEE-488 interface to put the Product into remote operation mode, but it is not because the IEEE Standards tell you that the remote function to be sent to the device as the uniline message `REN`. This is also true for some other commands and functions, as shown in Table 5-3 with their RS-232 equivalents.

For these commands, the detailed command descriptions in Chapter 6 show a marked box beside RS-232, but no check marked box beside IEEE-488.

**Table 5-3. Commands for RS-232 Only**

<b>IEEE-488 Message</b>	<b>RS-232 Equivalent</b>
GTL	LOCAL command
GTR	REMOTE command
LLO	LOCKOUT command

8. Commands for IEEE-488

These are all of the commands but those used for RS-232 only, as shown above. All commands are moved through the IEEE-488 as data, but the commands LOCAL, REMOTE, and LOCKOUT, which are done per the IEEE Standards as uniline messages.

The detailed command descriptions in Chapter 6 show a check mark beside IEEE-488 for these commands.

**Command Syntax**

The subsequent syntax rules are for all of the remote commands. Information about the syntax of response messages is also given.

1. Parameter Syntax Rules

Table 5-4 shows the units permitted in command parameters and used in responses. All commands and units can be recorded in upper or lower case.

**Table 5-4. Units Accepted in Parameters and Used in Responses**

Units	Meaning
μV	Volts in units of microvolts <sup>[1]</sup>
mV	Volts in units of millivolts <sup>[1]</sup>
V	Volts in units of volts
kV	Volts in units of kilovolts <sup>[1]</sup>
μA	Current in units of microamperes <sup>[1]</sup>
mA	Current in units of milliamps <sup>[1]</sup>
A	Current in units of amps
Ohm	Resistance in units of ohms
kOhm	Resistance in units of kilohms <sup>[1]</sup>
MOhm	Resistance in units of megohms <sup>[1]</sup>
cel	Temperature in degrees Celsius
far	Temperature in degrees Fahrenheit
psi	Pressure in pounds per square inch
mmHg	Pressure in millimeters of mercury at 0 °C
inHg	Pressure in inches of mercury at 0 °C
inH2O4C	Pressure in inches of water at 4 °C
inH2O20C	Pressure in inches of water at 20 °C
inH2O60F	Pressure in inches of water at 60 °F
cmH2O4C	Pressure in centimeters of water at 4 °C
cmH2O20C	Pressure in centimeters of water at 20 °C
mmH2O4C	Pressure in millimeters of water at 4 °C
mmH2O20C	Pressure in millimeters of water at 20 °C
bar	Pressure in bar
mbar	Pressure in millibar
kPa	Pressure in kilopascals
MPa	Pressure in megapascals
kg/cm2	Pressure in kilograms per square centimeter
[1] Parameter only	

## 2. General Rules

The general rules for parameter use are:

- Numeric parameters can have a maximum of 15 important digits and their value can be in the range +/-1.0E+/-20.
- You must include the correct number of parameters. This causes a command error.
- Null parameters cause an error, for example, the adjacent commas in OUT 1V,,; OPER.
- Expressions, for example 4+2\*13, cannot be used as parameters.

### 3. More Space or Tab Characters

In the command descriptions, parameters are shown isolated by spaces. One space after a command is necessary (unless no parameters are necessary). All other spaces are optional. Spaces are put in for clarity in the manual and can be left in or left out as necessary. You can put more spaces or tabs between parameters as necessary. More spaces in a parameter are typically not permitted. You can have more spaces between a number and its related multiplier or unit.

### 4. Terminators

Table 5-5 summarizes the terminator characters for both the IEEE-488 and the RS-232 remote interfaces.

**Table 5-5. Terminator Characters**

Terminator Function	ASCII Character		Control Command Terminator	Language Command Terminator
	Number	Program		
Carriage Return (CR)	13	Chr(13)	<Cntl> M	\n
Line Feed (LF)	10	Chr(10)	<Cntl> J	\r
Backspace (BS)	8	Chr(8)	<Cntl> H	\b
Form Feed (FF)	12	Chr(12)	<Cntl> L	\f
Examples: RS-232 Mode, terminal: OUT 1 V <Enter> RS-232 Mode, program: Comm1.Output = "OUT 1 V" + Chr(10) IEEE-488 Mode: OUT 1 V				

IEEE-488 interface:

The Product sends the ASCII character Carriage Return with the EOI control line held high as the terminator for response messages. The Product recognizes the subsequent as terminators when found in incoming data:

- ASCII CR character
- All ASCII character sent with the EOI control line asserted

RS-232 interface:

The Product sends a Carriage Return (CR) character as the terminator for response messages. The Product recognizes the subsequent as terminators when found in incoming data:

- ASCII CR character
- ASCII LF character

### 5. Incoming Character Processing

The Product processes all incoming data as follows:

- The most significant data bit (DIO8) is ignored
- All data is read as 7-bit ASCII
- Lower case or upper case characters are accepted, with lower case changed to upper case before they are used.

6. Response Message Syntax

In the complete command descriptions in Chapter 6, the responses from the Product are given where applicable. To know what type of data to read in, refer to the start of the response description for the command.

**Check Product Status**

Figure 5-4 shows the status registers, enable registers, and queues in the Product which show different conditions in the Product. Some registers and queues are specified by the IEEE-488.2 standard, while the others are only for the Product. With the status registers, the Service Request (SRQ) control line and a 16-element buffer (the Error Queue) also give status information.

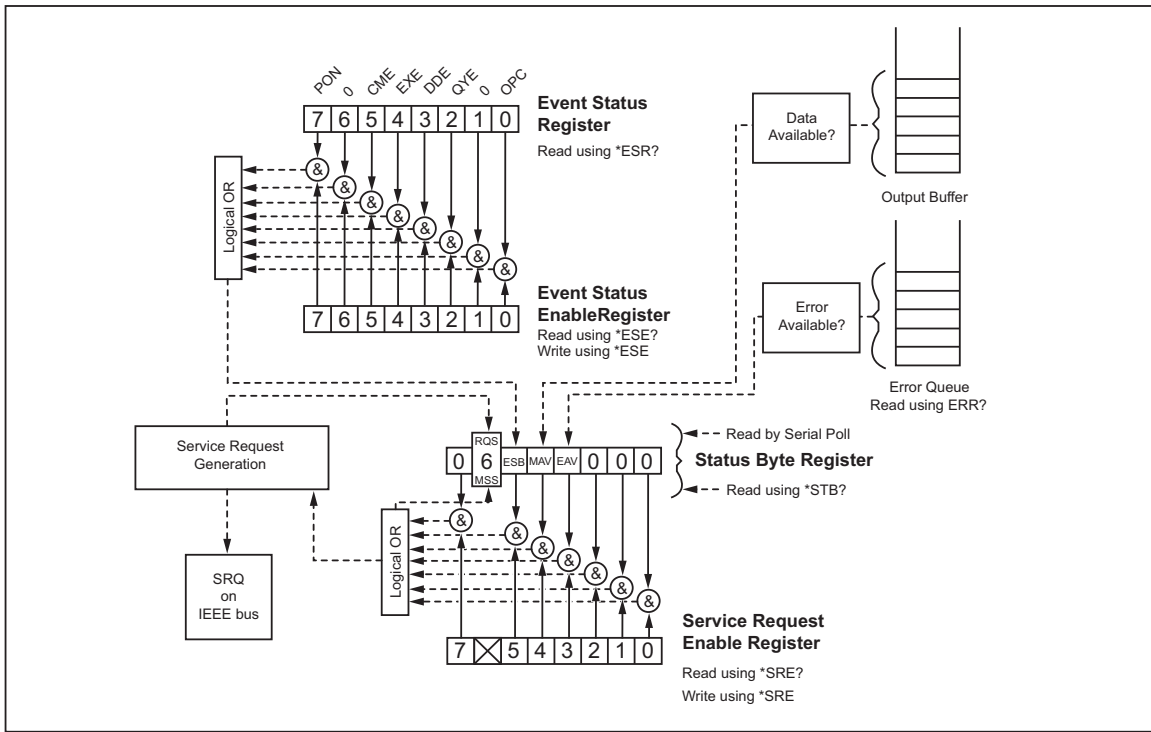

Figure 5-4. Status Register Overview

gwp033.eps

Table 5-6 shows the status registers and gives the read/write commands and related mask registers to use them.

Table 5-6. Status Register Summary

Status Register	Read Command	Write Command
Serial Poll Status Byte (STB)	*STB?	—
Service Request Enable Register (SRE)	*SRE?	*SRE
Event Status Register (ESR)	*ESR?	—
Event Status Enable Register (ESE)	*ESE?	*ESE

Each status register and queue has a summary bit in the Serial Poll Status Byte. Enable registers are used to mask different bits in the status registers and to make summary bits in the Serial Poll Status Byte. For IEEE-488 interface operation, the Service Request Enable Register is used to assert the SRQ control line on detection of A status condition or conditions that the programmer chooses. For RS-232 interface operation, the SRQSTR string is sent through the serial interface when the SRQ line is set.

1. Serial Poll Status Byte (STB)

The Calibrator sends the serial poll status byte (STB) when it answers to a serial poll. This byte is set to 0 when the power is turned on. The STB byte structure is shown in Table 5-7. Refer to the \*STB? command in Chapter 6 for more information on how to read this register.

**Table 5-7. Serial Poll Status Byte (STB) and Service Request Enable (SRE) Registers**

7	6	5	4	3	2	1	0
0	RQS	ESB	MAV	EAV	0	0	0
	MSS						
RQS	Requesting Service. The RQS bit is set to 1 when bits ESB, MAV, EAV, or ISCB change from 0 to 1 and are enabled (1) in the SRE. When RQS is 1, the Product asserts the SRQ control line on the IEEE-488 interface. You can do a serial poll to read this bit to see if the Product is the source of an SRQ.						
MSS	Master Summary Status. Set to 1 when bits ESB, MAV, EAV, or ISCB are 1 and enabled (1) in the SRE. This bit can be read with the *STB? Remote command in place of a serial poll. Set to 1 when one or more ESR bits are 1.						
MAV	Message Available. The MAV bit is set to 1 when data is available in the IEEE-488 interface output buffer of the Product.						
EAV	Error Available. An error has occurred and an error is available to be read from the error queue with the FAULT? query.						

2. Service Request (SRQ) Line

IEEE-488 Service Request (SRQ) is an IEEE-488.1 bus control line that the Product asserts to tell the controller that some type of service is necessary. Many instruments can be on the bus, but they all share one SRQ line. To find which instrument set SRQ, the Controller typically does a serial poll of each instrument. The calibrator asserts SRQ when the RQS bit in its Serial Poll Status Byte is 1. This bit tells the controller that the Product was the source of the SRQ.

The Product clears SRQ and RQS when the controller/host does a serial poll, sends \*CLS, or when the MSS bit is cleared. The MSS bit is cleared only when ESB and MAV are 0, or they are disabled when their related enable bits in the SRE register are set to 0.

3. Service Request Enable Register (SRE)

The Service Request Enable Register (SRE) enables or masks the bits of the Serial Poll Status Byte. The SRE is cleared at power up. Refer to Table 5-8 for the bit functions.

4. Programming the STB and SRE

When you reset (to 0) the bits in the SRE, you can mask (disable) related bits in the serial poll status byte. Bits set to 1 enable the related bit in the serial poll status byte.



5. Event Status Register (ESR)

The Event Status Register is a two-byte register in which the higher eight bits are always 0, and the lower eight bits show different conditions of the Product. The ESR is cleared (set to 0) when the power is turned on, and each time it is read.

Parameters are necessary for many of the remote commands. Incorrect parameter use causes command errors to occur. When a command error occurs, bit CME (5) in the Event Status Register (ESR) goes to 1 (if enabled in ESE register), and the error is logged in the error queue.

6. Event Status Enable (ESE) Register

A mask register named the Event Status Enable register (ESE) lets the controller enable or mask (disable) each bit in the ESR. When a bit in the ESE is 1, the related bit in the ESR is enabled. When an enabled bit in the ESR is 1, the ESB bit in the Serial Poll Status Byte also goes to 1. The ESR bit stays 1 until the controller reads the ESR, does a device clear, a selected device clear, or sends the reset or \*CLS command to the Product. The ESE is cleared (set to 0) when the power is turned on.

7. Bit Assignments for the ESR and ESE

The bits in the Event Status Register (ESR) and Event Status Enable register (ESE) are as shown in Table 5-8.

**Table 5-8. Event Status Register (ESR) and Event Status Enable (ESE) Registers**

15	14	13	12	11	10	9	8
0	0	0	0	0	0	0	0
7	6	5	4	3	2	1	0
PON	0	CME	EXE	DDE	QYE	0	OPC
PON	Power on. This bit is set to 1 if line power has been turned off and on since the last time the ESR was read.						
CME	Command error. The IEEE-488 interface of the Product encountered an incorrectly formed command and placed an error code in the error queue. The command FAULT? can be used to fetch error codes from the error queue, which is described in more detail below.						
EXE	Execution error. An error occurred when the Product tried to execute the last command and an error code was placed into the error queue. This could be caused, for example, by a parameter being out of range. The command FAULT? can be used to fetch error codes from the error queue, which is described in more detail below.						
DDE	Device-dependent error. An error related to a device-dependent command has occurred.						
QYE	Query error. The Product was addressed to talk when no response data was available or appropriate, or when the controller failed to retrieve data from the output queue.						
OPC	Operation complete. All commands previous to reception of a *OPC command have been executed, and the interface is ready to accept another message.						

8. Programming the ESR and ESE

To read the contents of the ESR, send the remote command, \*ESR?. The ESR is cleared (set to 0) each time it is read. To read the contents of the ESE, send the remote command, \*ESE?. The ESE is not cleared when it is read. When you read registers, the Product shows a decimal number that when changed to binary refers to bits 0 through 15.

9. Output Queue

The output queue is loaded when a query is processed, and holds a maximum of 250

characters. The controller reads it with a statement such as a BASIC INPUT statement. What is read is removed from the queue. If the queue is empty, the Product does not answer to the INPUT statement from the controller. The Message Available (MAV) bit in the Serial Poll Status Byte is 1 if there is something in the output queue and 0 if the output queue is empty.

#### 10. Error Queue

When a command error, execution error, or device-dependent error occurs, its error code is put in the error queue where it can be read by the FAULT? command. If you read the first error with the FAULT? Command, this removes that error from the queue. A response of 0 means the error queue is empty. The error queue is cleared when you turn off the power, and when you use the \*CLS (Clear Status) common command. The error queue holds A maximum of 15 entries. If more than 15 errors occur, only the first 15 errors are kept in the queue. A 16th entry in the queue is always an "error queue overflow" error, and all new errors are discarded until part of the queue is read. The first errors are kept, because if many errors occur before the user can acknowledge and read them, the first errors are most likely to point to the problem. The newest errors are usually repetitions or consequences of the initial problem.

#### 11. Input Buffer Operation

As the Product gets each data byte from the controller, it puts the byte in a part of memory named the input buffer. The input buffer holds a maximum of 250 data bytes and operates in a first in, first out procedure.

IEEE-488 interface:

The Product works with the IEEE-488 EOI control line as an isolated data byte and puts it into the input buffer if it is found as part of a message terminator. Input buffer operation is transparent to the program on the controller. If the controller sends commands faster than the Product can do them, the input buffer fills to capacity. When the input buffer is full, the Product holds off the IEEE-488 bus with the NRFD (Not Ready For Data) handshake line. When the Product has processed a data byte from the full input buffer, it then completes the handshake. This lets the controller send a different data byte. The calibrator clears the input buffer on power-up and when receiving the DCL (Device Clear) or SDC (Selected Device Clear) message from the controller.

RS-232 interface:

The Product uses the RS-232-C Xon/Xoff protocol to control buffer overflow. The Product sends a Xoff (Ctrl S) character when the input buffer becomes 80 % full, and sends a Xon (Ctrl Q) character when it has processed a sufficient part of the input buffer so that it is less than 40 % full

# **Chapter 6**

## **Remote Commands**

<b>Title</b>	<b>Page</b>
Introduction.....	6-3
Command Summary by Function .....	6-3
Error Code List .....	6-6
Remote Command List .....	6-7



## Introduction

Remote commands duplicate actions that can be started from the front panel in local operation mode. After the summary table is a complete alphabetical list of all commands complete with protocol information. Headings in the alphabetical list give the parameters and responses, plus an example for each command. For information on how to use the commands, see Chapter 5.

## Command Summary by Function

See the subsequent tables for command summary function information.

**Table 6-1. Common Commands**

Command	Description
*CLS	Clear status. Clears the ESR, the error queue, and the RQS bit in the status byte. This command stops all pending operation complete commands, *OPC or *OPC?.
*ESE	Puts a byte into the Event Status Enable register.
*ESE?	Shows the contents of the Event Status Enable register.
*ESR?	Shows the contents of the Event Status register and clears the register.
*IDN?	Identification query. Shows the manufacturer, model number, serial number, and firmware revision level of the Calibrator.
*OPC	Sets bit 0 (OPC for Operation Complete) in the Event Status Register to 1 when all pending device operations are complete.
*OPC?	Shows a 1 after all subsequent operations are complete. This command causes program execution to pause until all operations are complete. See also the *WAI command.
*OPT?	Shows a list of the installed hardware and software options.
*RST	Resets the condition of the instrument to the power-up condition. This command holds off execution of subsequent commands until it is complete.
*SRE	Puts a byte into the Service Request Enable register (SRE).
*SRE?	Shows the byte from the Service Request Enable register.
*STB?	Shows the status byte.
*TST?	Does a series of self-tests and shows a "0" for pass or a "1" for fail. If faults are found, they are put into the fault queue where they can be read by the FAULT? query.
*WAI	Stops subsequent remote commands from execution until all remote commands from before are complete.

**Table 6-2. External Connection Commands**

Command	Description
FUNC?	Shows the current output, measurement, or calibration function selected on the isolated and primary displays, in that sequence.
HART?	Shows the HART resistor setting for the isolated milliamp range, ON or OFF.
HART_OFF	Turns off the HART resistor on the isolated milliamp range.
HART_ON	Turns on the HART resistor on the isolated milliamp range.
ISO_PRES_UNIT	Sets the isolated display pressure units.
ISO_PRES_UNIT?	Shows the isolated display pressure units.
LOOP_POWER?	Shows the 24V loop power setting for the isolated milliamp range, ON or OFF.
LOOP_POWER_OFF	Turns off the 24V loop power on the isolated milliamp range.
LOOP_POWER_ON	Turns on the 24V loop power on the isolated milliamp range.
PRES_UNIT	Sets the primary display pressure units.
PRES_UNIT?	Shows the primary display pressure units.
RTD_TYPE	Sets the Resistance Temperature Detector (RTD) type.
RTD_TYPE?	Shows the Resistance Temperature Detector (RTD) type.
TC_REF	Selects the internal temperature sensor or an external reference value for cold junction compensation of thermocouple (TC) source and measurement.
TC_REF?	Shows the source of the temperature that is used for cold junction compensation of thermocouple (TC) source and measurement.
TC_TYPE	Sets the thermocouple (TC) type.
TC_TYPE?	Shows the thermocouple (TC) type.
TSENS_TYPE	Sets temperature mode, RTD or TC.
TSENS_TYPE?	Shows the temperature mode.

**Table 6-3. Output Commands**

Command	Description
OPER	Starts the Calibrator output if it is in standby mode.
OPER?	Shows the operate/standby mode setting.
OUT	Sets the output of the Calibrator.
OUT?	Shows the current output value of the Calibrator.
RANGE?	Shows the current output range, for voltage and current only.
RANGELCK	Locks the current output range, for voltage only.
RANGELCK?	Shows the RANGELOCK condition, for voltage only.
STBY	Stops the Calibrator output if it is in operate mode.

**Table 6-4. Measurement Commands**

Command	Description
ISO_MEAS	Sets the isolated input measurement type.
PRES?	Queries the connected pressure module for its manufacturer and serial number.
PRES_MEAS	Changes the operation mode of the primary display to pressure measurement.
RTD_MEAS	Changes the operation mode to RTD measurement.
ST_START	Puts the Calibrator in switch test mode and/or starts a new switch test.
ST_CLOSE?	Shows the value at which the switch closed.
ST_OPEN?	Shows the value at which the switch opened.
ST_DEAD?	Shows the value of the dead band of the switch.
TC_MEAS	Changes the operation mode to thermocouple measurement.
VAL?	Shows the last values for the isolated and primary measurements, in that order.
ZERO_MEAS	Zeros the pressure module, TC mV, or RTD ohms.
ZERO_MEAS?	Shows the zero offset for the pressure module, TC mV, or RTD ohms.

**Table 6-5. RS-232 Operation Mode Commands**

Command	Description
LOCAL	Puts the Calibrator into the local condition and disables lockout.
LOCKOUT	Puts the Calibrator into the lockout condition. This command duplicates the IEEE-488 LLO (Local Lockout) message.
REMOTE	Puts the Calibrator into the remote condition. This command duplicates the IEEE-488 REN (Remote Enable) message.

**Table 6-6. Status Commands**

Command	Description
FAULT?	Shows the most recent error code in the Calibrator error queue, and then removes that error code from the queue.

## Error Code List

Table 6-7 is list of error codes for the Product.

**Table 6-7. Error Code List**

Error Number	Message Class	Description
1	DDE	Error queue overflow.
100	EXE	OPER or STBY was received when the Calibrator is in measure mode or thermocouple source mode.
101	CME	A non-numeric entry was received in a field that must contain a numeric entry.
102	EXE	The numeric field is more than 10 characters.
103	CME	incorrect units name or prefix.
104	EXE	An attempt to go into RTD source mode was made when SPRT is selected, or to select SPRT when RTD source mode is selected.
105	EXE	Entry is above top limit for the selected output range.
106	EXE	Entry is below lower limit for the selected output range.
108	CME	A necessary command parameter was missing.
109	CME	An incorrect TC_MEAS or RTD_MEAS unit parameter (not CEL or FAR) was received, or an incorrect PRES_UNIT or ISO_PRES_UNIT parameter was received.
110	CME	An incorrect RANGELCK parameter was received.
111	EXE	RANGELCK ON was received when the Calibrator is not in Volts mode.
112	CME	An incorrect RTD_TYPE parameter was received.
113	CME	An incorrect TC_REF parameter was received.
114	CME	An incorrect TSENS_TYPE parameter was received.
116	EXE	No pressure module was present when a pressure function was requested, or the total zero offset from calibration is more than 6%. This error can also occur if the total zero offset from calibration is out of limits when zeroing the thermocouple millivolts type (maximum offset $\pm 1$ mV), or the RTD ohms type (maximum $\pm 0.1$ ohm on high range, or $\pm 0.01$ ohm on the low range).
117	CME	An unrecognizable command was received.



**Table 6-7. Error Code List (cont.)**

Error Number	Message Class	Description
118	CME	An incorrect parameter was received.
120	EXE	The serial input buffer overflowed.
121	EXE	The command string buffer overflowed.
122	QYE	The serial output buffer overflowed.
123	DDE	The output overloaded. See display error message OVER LOAD in Chapter 1.
124	DDE	The Calibrator is out of tolerance. This error is set after a failed initialization or a failed *TST? command.
125	DDE	The Calibrator ADC has failed. This error is set after a failed initialization or a failed *TST? command.

## Remote Command List

An alphabetical list of all Calibrator remote commands and queries is shown below. This list includes common commands and the device-dependent commands. Each command title includes a checkbox that shows the remote interface applicability, IEEE-488 and/or RS-232, and the command group, Sequential or Overlapped. See the “Types of Commands” section of Chapter 5 for a description of these terms.

**\*CLS**  IEEE-488  RS-232  Sequential  Overlapped

Clear Status command. This command clears the ESR, the error queue, and the RQS bit in the status byte. This command stops pending operation complete commands, \*OPC or \*OPC?.

Parameter: <None>

Response: <None>

Example: \*CLS

This example clears the ESR, the error queue, and the RQS bit in the status byte.

---

**\*ESE**  IEEE-488  RS-232  Sequential  Overlapped

Event Status Enable command. This command puts a byte into the Event Status

Enable (ESE) register. See the Event Status Enable Register (ESE) description in the “Check Product Status” section of Chapter 5.

Parameter: <value>

where <value> is the decimal equivalent of the ESE byte, 0 to 255

Response: <None>

Example: \*ESE 140

This example loads decimal 140 (binary 10001100) to enable bits 7 (PON), 3 (DDE) and 2 (QYE).

---

**\* ESE?**                     IEEE-488    RS-232    Sequential    Overlapped

Event Status Enable query. This command shows the contents of the Event Status Enable (ESE) register. See the Event Status Enable Register (ESE) description in the “Check Product Status” section of Chapter 5.

Parameter:                    <None>

Response:                    <value>

where <value> is the decimal equivalent of the ESE byte, 0 to 255

Example:                    \*ESE?

133

This example shows decimal 133 (binary 10000101) which shows that bits 7 (PON), 2 (QYE), 1 (OPC) are enabled.

---

**\* ESR?**                     IEEE-488    RS-232    Sequential    Overlapped

Event Status Register query. This command shows the contents of the Event Status Register (ESR) and clears the register. See the Event Status Register (ESR) in the “Check Product Status” section of Chapter 5.

Parameter:                    <None>

Response:                    <value>

where <value> is the decimal equivalent of the ESR byte, 0 to 255

Example:                    \*ESR?

61

This example shows decimal 61 (binary 00111101) which is an indications that bits 5 (CME), 4 (EXE), 3 (DDE), 2 (QYE) and 0 (OPC) are enabled.

---

**FAULT?**

IEEE-488  RS-232  Sequential  Overlapped

This command shows the most recent error code from the error queue. If the queue is empty (no errors have occurred) it shows 0. The command is typically used to verify that the prior command did what it was intended to do.

Parameter: <None>

Response: <value>

where <value> is one of the error codes documented in Chapter 6.

Example: FAULT?

105

This example shows the error code which will occur if the prior command tried to set a value more than 100 mA for current output. The error code 105 is an indications that the value was above the maximum limit for the selected output range.

**FUNC?**

IEEE-488  RS-232  Sequential  Overlapped

This command shows the current output, measurement, or calibration function for the primary and isolated displays.

Parameter: <None>

Response: <isolated>,<primary>

where <isolated> is one of the following:

DC10V	measure DC voltage, 10V range
DC100V	measure DC voltage, 100V range
DCI	measure DC current
PRESSURE	measure pressure

and where <primary> is one of the following:

DCV	source DC voltage
DCI	source DC current
RTD_OUT	source RTD/Ohms
RTD_IN	measure RTD/Ohms
TC_OUT	source thermocouple
TC_IN	measure thermocouple
PRESSURE	measure pressure

Example: FUNC?

DC10V,PRESSURE

This example is an indication that the isolated display is selected to the 10V range and the primary display is selected to pressure.

---

**HART?**  IEEE-488  RS-232  Sequential  Overlapped

This command shows the isolated DC current input HART resistor status.

Parameter: <None>

Response: <value>

where <value> is ON or OFF

Example: HART?

OFF

This example is an indication that the isolated DC current input HART resistor is turned off.

---

**HART\_OFF**  IEEE-488  RS-232  Sequential  Overlapped

This command disables the isolated DC current input HART resistor.

Parameter: <None>

Response: <None>

Example: HART\_OFF

This example disables the isolated DC current input HART resistor.

---

**HART\_ON**  IEEE-488  RS-232  Sequential  Overlapped

This command enables the isolated DC current input HART resistor.

Parameter: <None>

Response: <None>

Example: HART\_ON

This example enables the isolated DC current input HART resistor.

---

**\*IDN?**  IEEE-488  RS-232  Sequential  Overlapped

This command shows the unit identification: instrument manufacturer, model number, serial number, and firmware revision level.

Parameter: <None>

Response: <text string>

where <text string> contains the subsequent four fields separated by commas:

1. Manufacturer
2. Model number
3. Serial number (always 0)
4. Firmware revision level

Example: \*IDN?

FLUKE, Calibrator,0,1.2

This example is an indication the manufacturer is Fluke, the model is Calibrator, the serial number is 0, and the firmware version is 1.2.

**ISO\_MEAS**  IEEE-488  RS-232  Sequential  Overlapped

This command sets the isolated measurement type.

Parameter: <value>

where <value> is one of these:

- |          |                                |
|----------|--------------------------------|
| DC10V    | measure DC voltage, 10V range  |
| DC100V   | measure DC voltage, 100V range |
| DCI      | measure DC current             |
| PRESSURE | measure pressure               |

Response: <None>

Example: ISO\_MEAS DCI

This example sets the isolated measurement to DC current.

**ISO\_PRES\_UNIT**

IEEE-488  RS-232  Sequential  Overlapped

This command sets the isolated pressure unit.

Parameter:

<value> where <value> is one of these:

PSI	pounds per square inch
INH2O4C	inches of water at 4 °C
INH2O20C	inches of water at 20 °C
INH2O60F	inches of water at 60 °F
CMH2O4C	centimeters of water at 4 °C
CMH2O20C	centimeters of water at 20 °C
MMH2O4C	millimeters of water at 4 °C
MMH2O20C	millimeters of water at 20 °C
BAR	bars
MBAR	millibars
KPA	kilopascals
MPA	megapascals
INHG	inches of mercury at 0 °C
MMHG	millimeters of mercury at 0 °C
KG/CM2	kilograms per square centimeter

Response:

<None>

Example:

ISO\_PRES\_UNIT BAR

This example sets the isolated pressure unit to bars.

---

**ISO\_PRES\_UNIT?**       IEEE-488    RS-232    Sequential    Overlapped

This command shows the isolated pressure unit.

Parameter:            <None>

Response:            <value>

where <value> is one of these:

PSI	pounds per square inch
INH2O4C	inches of water at 4 °C
INH2O20C	inches of water at 20 °C
INH2O60F	inches of water at 60 °F
CMH2O4C	centimeters of water at 4 °C
CMH2O20C	centimeters of water at 20 °C
MMH2O4C	millimeters of water at 4 °C
MMH2O20C	millimeters of water at 20 °C
BAR	bars
MBAR	millibars
KPA	kilopascals
MPA	megapascals
INHG	inches of mercury at 0 °C
MMHG	millimeters of mercury at 0 °C
KG/CM2	kilograms per square centimeter

Example:            ISO\_PRES\_UNIT?

BAR

This example is an indication that the isolated pressure unit is bars.

**LOCAL**                     IEEE-488    RS-232    Sequential    Overlapped

This command puts the Calibrator into the local condition, clearing the remote condition (see the REMOTE command) and the front panel lockout condition (see the LOCKOUT command). It duplicates the condition of when the IEEE-488 REN line to false.

Parameter:            <None>

Response:            <None>

Example:            LOCAL

This example puts the instrument into the local condition, clearing the remote condition and front panel lockout condition, if enabled.

**LOCKOUT**                     IEEE-488    RS-232    Sequential    Overlapped

This command puts the Calibrator into the lockout condition when in remote control (see the REMOTE command). In this condition, no local operation is permitted at the front panel. This includes the LOCAL key. To clear the lockout condition, use the LOCAL command. This command duplicates the IEEE-488 LLO (Local Lockout) message.

Parameter:                    <None>

Response:                    <None>

Example:                    LOCKOUT

This example puts the instrument into the lockout condition. No front panel controls can be used.

---

**LOOP\_POWER?**                 IEEE-488    RS-232    Sequential    Overlapped

This command shows the isolated DC current input 24V loop power status.

Parameter:                    <None>

Response:                    <value>

where <value> is ON or OFF

Example:                    LOOP\_POWER?

OFF

This example is an indication that the isolated DC current input 24V loop power is turned off.

---

**LOOP\_POWER\_OFF**             IEEE-488    RS-232    Sequential    Overlapped

This command disables the isolated DC current input 24V loop power.

Parameter:                    <None>

Response:                    <None>

Example:                    LOOP\_POWER\_OFF

This example disables the isolated DC current input 24V loop power.

---

**LOOP\_POWER\_ON**              IEEE-488    RS-232    Sequential    Overlapped

This command enables the isolated DC current input 24V loop power.

Parameter:                    <None>

Response:                    <None>

Example:                    LOOP\_POWER\_ON

This example enables the isolated DC current input 24V loop power.

---



**\*OPC**

IEEE-488  RS-232  Sequential  Overlapped

Operations Complete command. This command sets bit 0 (OPC) of the Event Status Register to 1 when all pending device operations are complete. Also see the \*ESR? command.

Parameter: <None>

Response: <None>

Example: \*OPC

This example sets bit 0 of the Event Status Register to 1 when all pending device operations are done.

**\*OPC?**

IEEE-488  RS-232  Sequential  Overlapped

Operations Complete query. This command shows a 1 after all pending Calibrator operations are complete. This command does not answer until all pending Calibrator operations are complete, and causes the control program execution to pause until operations are complete. Also see the \*WAI command.

Parameter: <None>

Response: 1

Example: \*OPC?

1

This example does not answer until all pending Calibrator operations are complete, and then shows 1.

**OPER**

IEEE-488  RS-232  Sequential  Overlapped

This command puts the Calibrator in operate mode and start the output at the front panel terminals. This command does the same as if you push the front panel key when in standby mode.

Parameter: <None>

Response: <None>

Example: OPER

This example connects the selected output to the Calibrator front panel terminals. It also shows Opr on the display.

**OPER?**

IEEE-488    RS-232    Sequential    Overlapped

This command shows the current operate/standby mode setting.

Parameter:            <None>

Response:            <value>

where <value> is "1" for operate mode and "0" for standby mode

Example:            OPER?

1

This example is an indication that the Calibrator is in operate mode.

---

**\*OPT?**

IEEE-488    RS-232    Sequential    Overlapped

This command shows a list of the installed hardware and software options. This command is reserved for future use.

Parameter:            <None>

Response:            <text string>

where <text string> is "0" if no options are installed, or a list of installed options separated by commas

Example:            \*OPT?

0

The example is an indication that no options are installed.

---

**OUT**

IEEE-488  RS-232  Sequential  Overlapped

This command sets the output mode and value of the Calibrator. To source a temperature, select the necessary mode and sensor parameters first with the TSENS\_TYPE, RTD\_TYPE, and TC\_TYPE commands. Use the multiplier prefixes k for kilo, m for milli, and u for micro with the OUT command units, as necessary. The unit can be ignored if the output mode is not to be changed.

Parameter: <value> <units>

where <value> is the output value to be made and where <units> is one of the items below, with a possible prefix multiplier (k, m, or u) as given above:

- V DC volts
- A DC current
- OHM Resistance
- CEL Temperature in Celsius
- FAR Temperature in Fahrenheit

Response: <None>

Examples:

	Explanation
OUT 15.2 V	Change to DC volts, output 15.2 V
OUT 1.2 mA	Change to DC current, output 1.2 mA, note units prefix multiplier m
OUT 5 Ohm	Change to Resistance, output 5 O
OUT 100 CEL	Change to temperature in °C, output 100 °C
OUT 3	No change to output mode, output a value of 3 in the current units

**OUT?**

IEEE-488    RS-232    Sequential    Overlapped

This command shows the current output value and units of the Calibrator.

Parameter:            <None>

Response:            <value>,<units>

where <value> is the current output value and where <units> is one of these:

V	DC volts
A	DC current
OHM	Resistance
CEL	Temperature in Celsius
FAR	Temperature in Fahrenheit

Examples:

Explanation

OUT?

1.88300E-02,A Current output is 18.83 mA

OUT?

1.23000E+00,V Current output is 1.23 V

OUT?

4.00000E+03,OHM Current output is 4.0 KO

OUT?

1.0430E+02,CEL Current output is 104.3 °C

---

**PRES?**

IEEE-488    RS-232    Sequential    Overlapped

This command queries the connected pressure module for its manufacturer, serial number, and firmware version.

Parameter:            <None>

Response:            <text string>

where <text string> contains the subsequent three fields isolated by commas:

1. Manufacturer
2. Serial number
3. Firmware revision level (always 0)

Example:

PRES?

FLUKE,610070,0

This example is an indication that the manufacturer is Fluke, the serial number is 610070, and the firmware version is 0.

---

**PRES\_MEAS**       IEEE-488    RS-232    Sequential    Overlapped

This command changes the primary display operation mode to pressure measurement.

Parameter:            <None>

Response:            <None>

Example:              PRES\_MEAS

This example changes the primary display operation mode to pressure measurement.

**PRES\_UNIT**       IEEE-488    RS-232    Sequential    Overlapped

This command sets the primary display pressure units.

Parameter:            <value>

where <value> is one of these:

PSI	pounds per square inch
INH2O4C	inches of water at 4 °C
INH2O20C	inches of water at 20 °C
INH2O60F	inches of water at 60 °F
CMH2O4C	centimeters of water at 4 °C
CMH2O20C	centimeters of water at 20 °C
MMH2O4C	millimeters of water at 4 °C
MMH2O20C	millimeters of water at 20 °C BAR bars
MBAR	millibars
KPA	kilopascals
MPA	megapascals
INHG	inches of mercury at 0 °C
MMHG	millimeters of mercury at 0 °C
KG/CM2	kilograms per square centimeter

Response:            <None>

Example:              PRES\_UNIT BAR

This example sets the primary display pressure units to bars.

**PRES\_UNIT?**

IEEE-488    RS-232    Sequential    Overlapped

This command shows the primary display pressure units.

Parameter:            <None>

Response:            <value>

where <value> is one of these:

PSI	pounds per square inch
INH2O4C	inches of water at 4 °C
INH2O20C	inches of water at 20 °C
INH2O60F	inches of water at 60 °F
CMH2O4C	centimeters of water at 4 °C
CMH2O20C	centimeters of water at 20 °C
MMH2O4C	millimeters of water at 4 °C
MMH2O20C	millimeters of water at 20 °C
BAR	bars
MBAR	millibars
KPA	kilopascals
MPA	megapascals
INHG	inches of mercury at 0 °C
MMHG	millimeters of mercury at 0 °C
KG/CM2	kilograms per square centimeter

Example:            PRES\_UNIT?

BAR

This example shows that the primary pressure display units are bars.

---

**RANGE?**  IEEE-488  RS-232  Sequential  Overlapped

This command shows the current DC voltage or current output range.

Parameter: <None>

Response: <value>

where <value> is one of these:

V_0.1V	DC volts, 100 mV range
V_1V	DC volts, 1V range
V_10V	DC volts, 10 V range
V_100V	DC volts, 100 V range
A_0.1A	DC current
NONE	neither volts nor current is selected

Example: RANGE?

V\_10V

This example is an indication that the current output range is 10 V.

**RANGELCK**  IEEE-488  RS-232  Sequential  Overlapped

This command locks or unlocks the DC voltage output range in reference to the current output value.

Parameter: <value>

where <value> is one of these:

ON	to lock the current voltage range
OFF	to unlock the current voltage range

Response: <None>

Example: RANGELCK ON

If the current DC voltage output is 5 V, this example locks the range at 10 VDC.

**RANGELCK?**

IEEE-488    RS-232    Sequential    Overlapped

This command shows the DC voltage range lock status.

Parameter:            <None>

Response:            <value>

where <value> is one of these:

          ON            DC voltage range lock is on

          OFF           DC voltage range lock is off

Example:            RANGELCK?

                      OFF

                      This example is an indication that the range lock is off.

---

**REMOTE**

IEEE-488    RS-232    Sequential    Overlapped

This command puts the Calibrator into the remote condition. It duplicates the IEEE-488 REN (Remote Enable) message. When the Calibrator is in the remote condition, but not locked out, only the LOCAL key is active. If the front panel is also locked out, no front panel keys are active. See the LOCKOUT command. To unlock the front panel, use the LOCAL command, or push the Calibrator power switch.

Parameter:            <None>

Response:            <None>

Example:            REMOTE

                      This example places the Calibrator into the remote condition.

---



**\*RST**                     IEEE-488    RS-232    Sequential    Overlapped

This command resets the Calibrator to the power-up condition and holds off execution of subsequent commands until the reset operation is complete.

A reset action invokes the subsequent commands and values for the primary display:

<u>Command</u>	<u>Value</u>
OUT	0 V
PRES_UNIT	Last selected
RANGE	0.1 V
RTD_TYPE	Last selected
STBY	(No output)
TC_REF	INT
TC_TYPE	Last selected
TSENS_TYPE	Last selected

The isolated display and selections stay as they were last selected.

Parameter:            <None>

Response:            <None>

Example:              \*RST

This example resets the Calibrator, invoking the commands and values shown above.

**RTD\_MEAS**             IEEE-488    RS-232    Sequential    Overlapped

This command puts the primary display in RTD measure mode.

Parameter:            <value>

where <value> is one of the these:

CEL	display in degrees Celsius
FAR	display in degrees Fahrenheit
<None>	display in the last selected temperature unit

Response:            <None>

Example:              RTD\_MEAS CEL

This example puts the Calibrator to RTD measure mode and shows in degrees Celsius.

## RTD\_TYPE

IEEE-488  RS-232  Sequential  Overlapped

This command sets the Resistance Temperature Detector (RTD) sensor type for RTD source and measure. Typically, before you use the RTD\_TYPE command to select the RTD type, use the TSENS\_TYPE command to select RTD mode, and afterwards set the output temperature with the OUT command, if applicable. A change in temperature sensors sets the output to 0 °C. Note that the SPRT can only be used to measure signals, not source them.

Parameters:

<value>

where <value> is one of the these:

PT385_100	100-ohm RTD, curve a=0.00385 ohms/ohm/°C
PT385_200	200-ohm RTD, curve a=0.00385 ohms/ohm/°C
PT385_500	500-ohm RTD, curve a=0.00385 ohms/ohm/°C
PT385_1000	1000-ohm RTD, curve a=0.00385 ohms/ohm/°C
PT392_100	100-ohm RTD, curve a=0.003926 ohms/ohm/°C
PTJIS_100	100-ohm RTD, curve a=0.003916 ohms/ohm/°C
CU10	10-ohm RTD, empirical curve
NI120	120-ohm RTD, empirical curve
YSI_400	YSI thermistor curve
OHMS_HIGH	4000 ohms range
OHMS_LOW	400 ohms range
SPRT	standard PRT with user defined error coefficients, only available for measurement
USR_DEF<x>	RTD with user defined custom coefficients, where x is the curve number and ranges from 1 to 5, i.e. USR_DEF2 for curve 2

Response:

<None>

Example:

RTD\_TYPE PTJIS\_100

This example puts the RTD sensor to a 100-ohm type, with the PT3916 curve (a=0.003916 ohms/ohm/°C). The resistance of 100 ohms refers to the ice point property, the resistance of the RTD at 0 °C (32 °F).

---

**RTD\_TYPE?**

IEEE-488    RS-232    Sequential    Overlapped

This command shows the Resistance Temperature Detector (RTD) sensor type that is in operation for RTD temperature source and measurement.

Parameter:                    <None>

Response:                    <value>

where <value> is one of these:

- PT385\_100                    100-ohm RTD, curve a=0.00385  
ohms/ohm/°C
- PT385\_200                    200-ohm RTD, curve a=0.00385  
ohms/ohm/°C
- PT385\_500                    500-ohm RTD, curve a=0.00385  
ohms/ohm/°C
- PT385\_1000                    1000-ohm RTD, curve a=0.00385  
ohms/ohm/°C
- PT392\_100                    100-ohm RTD, curve a=0.003926  
ohms/ohm/°C
- PTJIS\_100                    100-ohm RTD, curve a=0.003916  
ohms/ohm/°C
- CU10                         10-ohm RTD, empirical curve
- NI120                         120-ohm RTD, empirical curve
- YSI\_400                      YSI thermistor curve
- OHMS\_HIGH                    4000 ohms range
- OHMS\_LOW                     400 ohms range
- SPRT                         standard PRT with user-specified error  
coefficients, only available for  
measurement
- USR\_DEF<x>                    RTD with user-specified custom  
coefficients, where x is the curve  
number and ranges from 1 to 5, i.e.  
USR\_DEF2 for curve 2

Example:                    RTD\_TYPE?  
PTJIS\_100

This example is an indication that the RTD sensor type is a 100-ohm RTD with curve a=0.3916 ohm/°C.

**\*SRE**  IEEE-488  RS-232  Sequential  Overlapped

Service Request Enable command. This command puts a byte into the Service Request Enable (SRE) register. See the Service Request Enable Register (SRE) description in the “Check Product Status” section of Chapter 5. Since bit 6 is not used (decimal value 64), the maximum entry is  $255 - 64 = 191$ .

Parameter: <value>

where <value> is the decimal equivalent of the SRE byte, 0 to 191

Response: <None>

Example: \*SRE 48

This example enables bits 4 (MAV) and 5 (ESB).

---

**\*SRE?**  IEEE-488  RS-232  Sequential  Overlapped

Service Request Enable query. This command shows the byte in the Service Request Enable Register (SRE). See the Service Request Enable Register (SRE) description the “Check Product Status” section of Chapter 5.

Parameter: <None>

Response: <value>

where <value> is the decimal equivalent of the SRE byte, 0 to 191

Example: \*SRE?

48

This example is an indication that bits 4 (MAV), and 5 (ESB) are enabled.

---

**\*STB?**  IEEE-488  RS-232  Sequential  Overlapped

Status Byte Register query. This command shows the byte in the Status Byte Register. See the Status Byte Register (STB) description in the “Check Product Status” section of Chapter 5.

Parameter: <None>

Response: <value>

where <value> is the decimal equivalent of the STB byte, 0 to 255

Example: \* STB?

96

This example is an indication that bits 5 (ESB) and 6 (MSS) are set.

---

**STBY**

IEEE-488  RS-232  Sequential  Overlapped

This command puts the Calibrator in standby mode. This stops the output at front panel terminals. This command does the same as if you push the front panel key when in operate mode.

Parameter: <None>

Response: <None>

Example: STBY

This example disconnects the selected output from the Calibrator front panel terminals. It also shows Stby on the display.

**ST\_START**

IEEE-488  RS-232  Sequential  Overlapped

This command puts the Calibrator in switch test mode and starts a new switch test. If the calibrartor is already is switctest mode it simply starts a new switch test.

Parameter: <None>

Response: <None>

Example: ST\_START

This example puts the calibrator in switch test mode and starts a new switch test

**ST\_CLOSE?**

IEEE-488  RS-232  Sequential  Overlapped

In switch test recall mode this command shows the value at which the switch closed.

Parameter: <None>

Response: <value>,<units>

where <value> is the value recorded from the primary display at the time the switch closed and where <units> are the units recorded from the primary display at the time the test was done.

Example: ST\_CLOSE?

5.00000E+01,CEL

This example shows the value at which a temperature switch closed in Celsius.

**ST\_OPEN?**

IEEE-488    RS-232    Sequential    Overlapped

In switch test recall mode, this command shows the value at which the switch opened.

Parameter:            <None>

Response:            <value>,<units>

where <value> is the value recorded from the primary display at the time the switch opened and where <units> are the units recorded from the primary display at the time the test was done.

Example:            ST\_OPEN?

5.53000E+01,CEL

This example shows the value at which a temperature switch opened in Celsius.

---

**ST\_DEAD?**

IEEE-488    RS-232    Sequential    Overlapped

In switch test recall mode this command shows the dead band of the switch.

Parameter:            <None>

Response:            <value>,<units>

where <value> is the deadband of the switch. To calculate this, subtract the second recorded contact transition from the first recorded contact transition and where <units> are the units recorded from the primary display at the time the test was done.

Example:            ST\_DEAD?

5.30000E+00,CEL

This example shows the value of the calculated deadband temperature of the switch in Celsius.

---

**TC\_MEAS**                     IEEE-488    RS-232    Sequential    Overlapped

This command places the primary display in thermocouple measure mode.

Parameter:                    <value>  
                                   where <value> is one of these:  
                                   CEL            display in degrees Celsius  
                                   FAR            display in degrees Fahrenheit  
                                   <None>        display in the last selected temperature unit

Response:                    <None>

Example:                      TC\_MEAS FAR  
                                   This example puts the Calibrator into thermocouple measure mode, and shows in degrees Fahrenheit.

**TC\_REF**                       IEEE-488    RS-232    Sequential    Overlapped

This command selects the internal temperature sensor or an external reference value for cold junction compensation of thermocouple source and measurement.

Parameter:                    <value>  
                                   where <value> is one of these:  
                                   INT            use internal temperature sensor  
                                   EXT            use external reference value

Response:                    None

Example:                      TC\_REF EXT  
                                   This example sets the thermocouple reference to external.

**TC\_REF?**                       IEEE-488    RS-232    Sequential    Overlapped

This command shows the source of the temperature that is used for cold junction compensation of thermocouple source and measurement.

Parameter:                    <None>  
 Response:                    <value>  
                                   where <value> is one of these:  
                                   INT    internal temperature sensor in use  
                                   EXT    external reference value in use

Example:                      TC\_REF?  
                                   INT  
                                   This example is an indication that the internal sensor is in use.

## TC\_TYPE

IEEE-488  RS-232  Sequential  Overlapped

This command sets the Thermocouple (TC) sensor type that is used for TC temperature source and measurement. Typically, before you use the TC\_TYPE command to select the TC type, use the TSENS\_TYPE command to select TC mode, and afterwards set the output temperature with the OUT command, if applicable. A change in temperature sensors sets the output to 0 °C.

Parameters: <value>

where <value> is one of these:

B	B-type thermocouple
C	C-type thermocouple
E	E-type thermocouple
J	J-type thermocouple
K	K-type thermocouple
L	L-type thermocouple
N	N-type thermocouple
R	R-type thermocouple
S	S-type thermocouple
T	T-type thermocouple
U	U-type thermocouple
XK	XK-type thermocouple
BP	BP-type thermocouple
Z	1 mV/°C

Response: <None>

Example: TC\_TYPE J

This example sets the thermocouple type to J-type.

---



**TC\_TYPE?**                     IEEE-488    RS-232    Sequential    Overlapped

This command shows the Thermocouple (TC) sensor type that is used for TC temperature source and measurement.

Parameter:

Response:                    <None>

                                 <value>

                                 where <value> is one of these:

B	B-type thermocouple
C	C-type thermocouple
E	E-type thermocouple
J	J-type thermocouple
K	K-type thermocouple
L	L-type thermocouple
N	N-type thermocouple
R	R-type thermocouple
S	S-type thermocouple
T	T-type thermocouple
U	U-type thermocouple
XK	XK-type thermocouple
BP	BP-type thermocouple
Z	1 mV/°C

Example:                    TC\_TYPE?

                                 K

                                 This example is an indication that the thermocouple sensor type is K-type.

**TSENS\_TYPE**                     IEEE-488    RS-232    Sequential    Overlapped

This command puts the temperature mode to thermocouple (TC) or Resistance Temperature Detector (RTD) for temperature source and measurement.

Parameters:                    <value>

                                 where <value> is one of these:

TC	Thermocouple
RTD	Resistance Temperature Detector

Response:                    <None>

Example:                    TSENS\_TYPE RTD

                                 This example sets the temperature mode to RTD.

**TSENS\_TYPE?**       IEEE-488    RS-232    Sequential    Overlapped

This command shows the current temperature mode, thermocouple (TC) or Resistance Temperature Detector (RTD).

Parameter:            <None>

Response:             <value>

where <value> is one of these:

    TC      Thermocouple

    RTD     Resistance Temperature Detector

Example:              TSENS\_TYPE?

TC

This example is an indication that the current temperature mode is thermocouple.

---

**\*TST?**                 IEEE-488    RS-232    Sequential    Overlapped

This command does a series of self-tests and shows a "0" for pass or a "1" for fail. If faults are found, they are put into the fault queue where they can be read by the FAULT? query.

Parameter:            <None>

Response:             <value>

where <value> is one of these:

    0                failed self-test

    1                passed self-test

Example:              \*TST?

1

This example runs the self-test and shows that it passed.

---

**VAL?**

IEEE-488    RS-232    Sequential    Overlapped

This command shows the last values for the isolated and primary measurements, in that sequence.

Parameter: <None>

Response: <iso-value>,<iso-units>,<primary-value>,<primary-units>

where <iso-value> is the current isolated measurement expressed in scientific notation.

and where <iso-units> is one of these:

V	DC volts
A	DC current
OVER	measurement is over or under range
or	one of the pressure units listed with the ISO_PRES_UNIT? command

and where <primary-value> is the current primary measurement expressed in scientific notation.

and where <primary-units> is one of these:

FAR	°F
CEL	°C
OHM	Ohms
V	DC volts (thermocouple millivolts)
OVER	measurement is over or under range
NONE	primary display is currently set to a source mode
or	one of the pressure units listed with the PRES_UNIT? command

Example: VAL?

2.137000E+00,V,5.763300E+01,CEL

This example is an indication that the isolated measurement is 2.137 volts and that the primary measurement is 57.633 °C.

**\*WAI**

IEEE-488    RS-232    Sequential    Overlapped

This command prevents further remote commands from being executed until all prior remote commands are complete. For example, if you send an OUT command, you can cause the Calibrator to wait until the output has settled before continuing on to the next command if you follow OUT with a \*WAI command. The \*WAI command is useful with all overlapped commands. This prevents the Calibrator from processing other commands until the overlapped command is complete.

Parameter:            <None>  
Response:             <None>  
Example:               OUT 1.1 V  
                         \*WAI  
                         OPER  
                         FAULT?

This example demonstrates setting the Calibrator output to 1.1 volts, waiting for the output to become stable before activating the output and checking if the sequence of commands completed successfully.

---

**ZERO\_MEAS**

IEEE-488    RS-232    Sequential    Overlapped

This command zeros a pressure module, the thermocouple mV offset, or the RTD ohms offset. For more zeroing instructions for RTD ohms, thermocouple millivolts, or pressure, see Chapter 2.

Parameter:            <None> for RTD ohms, thermocouple millivolts, or a pressure module that does not measure absolute pressure  
                         <value> is barometric pressure for absolute pressure modules, expressed in the currently selected pressure units  
Response:             <None>  
Example:               ZERO\_MEAS

If thermocouple millivolts are currently selected, this example zeros the offset.

---

**ZERO\_MEAS?**

IEEE-488    RS-232    Sequential    Overlapped

This command shows the zero offset for pressure modules, thermocouple millivolts, or RTD ohms.

Parameter:                    <None>

Response:                    <zero offset>,<units>

where < zero offset > is the current offset. and where <units> is one of these:

OHM	Ohms
V	DC volts (thermocouple millivolts)
or	one of the pressure units listed with the PRES_UNIT? command

Example:                    ZERO\_MEAS?

1.060000E-01,PSI

This example is an indication that the pressure zero for the connected module is 0.106 psi.



# **Chapter 7**

## ***Maintenance***

<b>Title</b>	<b>Page</b>
Introduction.....	7-3
Clean the Calibrator.....	7-3
Replace a Line Fuse.....	7-3
Change the Line Voltage .....	7-3





## Introduction

This chapter tells you how to do the usual maintenance and tasks necessary to keep the Product in service.

### Warnings

To prevent possible electrical shock, fire, or personal injury:

- **Have an approved technician repair the Product.**
- **Disconnect the mains power cord before you remove the Product covers.**
- **Do not operate the Product with covers removed or the case open. Hazardous voltage exposure is possible.**
- **Use only specified replacement parts.**

## Clean the Calibrator



Clean the Calibrator and pressure modules with a soft cloth dampened with water, or mild soap and water.

## Replace a Line Fuse

The line power fuses and line voltage selector are found in the compartment above the power switch on the right rear side of the Calibrator. See the rear-panel layout in Chapter 1.

Table 7-1 shows the correct replacement fuse for each line voltage setting.

**Table 7-1. Replacement Fuses**

Fuse Description	Line Voltage Setting
 0.25 A/250 V (SB)	120 V (100 V to 120 V) $\pm 10$ % about setting
 0.125 A/250 V (SB)	220 V (198 V to 240 V) $\pm 10$ % about setting
 To ensure safety, use exact replacement only.	

To examine or replace a fuse:

1. Disconnect the line power.
2. Use the blade of a flat screwdriver to pry up the tab at the base of the line fuse compartment. Insert the blade into the center slot under the tab. The compartment cover will come part way out.
3. Remove the compartment cover. The fuses come out with the compartment cover and can easily be examined or replaced.
4. To install the fuse holder, push the compartment cover back into the compartment until the tab locks in position.

## Change the Line Voltage

The Calibrator comes from the factory configured for the line voltage applicable for the country of purchase, or as specified when it is ordered. To verify the line voltage setting, examine the line voltage indicator on the power line fuse compartment cover.

Make sure that the line voltage selection is set for 120 V for line voltages between 100 V

and 120 V  $\pm 10$  % about setting, or that the selector is set to 240 V for line voltages between 220 V and 240 V  $\pm 10$  % about setting.