

SmartPower™ Solutions



WirelessHART

NOTICE

This guide provides basic guidelines for the SmartPower family of products. It does not provide instructions for detailed configuration, diagnostics, maintenance, service, troubleshooting, or installation of wireless devices. Refer to the wireless device's manuals and Quick Start Guides (QSG) for more instruction. This guide is also available electronically on EmersonProcess.com/Rosemount.

⚠ WARNING

Explosions could result in death or serious injury.

Installation of this power module in an explosive environment must be in accordance with the appropriate local, national, and international standards, codes, and practices. Review the Product Certifications section for any restrictions associated with a safe installation.

- Before connecting a Field Communicator in an explosive atmosphere, ensure the instruments are installed in accordance with intrinsically safe or non-incendive field wiring practices.

Electrical shock can result in death or serious injury.

- Avoid contact with the leads and terminals. High voltage that may be present on leads can cause electrical shock. The power module may be replaced in a hazardous area. The power module has surface resistivity greater than one gigaohm and must be properly installed in the wireless device enclosure. Care must be taken during transportation to and from the point of installation to prevent electrostatic charge build-up.

⚠ CAUTION

Each black power module contains two "C" size primary lithium batteries. Each green power module contains one "D" size primary lithium battery. Primary lithium batteries are regulated in transportation by the U.S. Department of Transportation, and are also covered by IATA (International Air Transport Association), ICAO (International Civil Aviation Organization), and ARD (European Ground Transportation of Dangerous Goods). It is the responsibility of the shipper to ensure compliance with these or any other local requirements. Please consult current regulations and requirements before shipping.

Contents

Warning on product labels	3	Disposal/recycling of depleted power modules	7
Physical installation	4	Product Certifications	9
Verify operation	5		

1.0 Warning on product labels

The Rosemount 701P power modules each have a warning printed on them. In each case the warning text is the same. Below is a figure that shows each label.

The text of the warning is: “WARNING Potential Static Hazard, Use Caution when Handling. Risk of Fire, Explosion or Severe Burn Hazard. DO NOT Recharge, Disassemble, Heat above 100 °C, Incinerate or Expose Contents to Water. Li metal content approx 5g.”

Figure 1. Warning Label on 701PBK

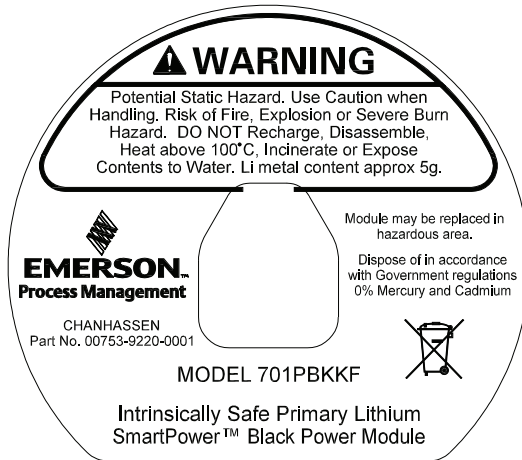
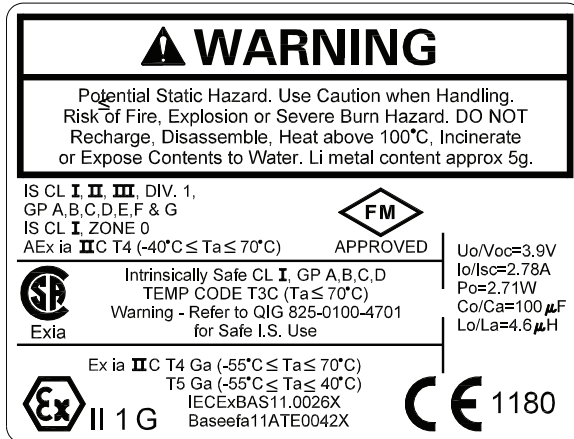

Figure 2. Warning Label on 701PGN



2.0 Physical installation

There are two types of power modules that will be discussed in this document. They are the black power module (701PBK) and the green power module (701PGN).

Figure 3. Black Power Module Installation

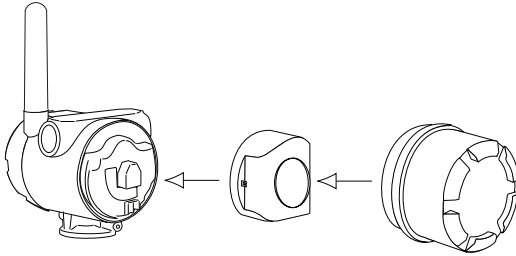

2.1 Black power module (701PBK)

1. Install the HART® device according to standard installation practices and the manufacturer's instructions, being sure to use an approved thread sealant on all connections.
2. Unscrew the power module cover from the wireless device.
3. Connect the power module to the wireless device. The power module has a keyed connection to prevent improper connection.

Note

Wireless devices should be powered up in order of proximity from the Smart Wireless Gateway, beginning with the closest device to the Gateway. This will result in a simpler and faster network installation.

-
4. Close the housing cover and tighten. Always ensure a proper seal by installing the electronics housing covers so that metal touches metal, but do not over tighten.

Figure 4. Green Power Module Installation

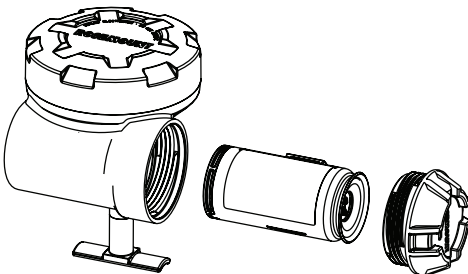

2.2 Green power module (701PGN)

1. Install the HART device according to standard installation practices and the manufacturer's instructions, being sure to use an approved thread sealant on all connections.
2. Unscrew the power module cover from the wireless device.
3. Connect the green power module to the wireless device. The green power module has a keyed connection to prevent improper connection. If the Green power module is placed into the housing the wrong way, it will not fit entirely into the housing.

Note

Wireless devices should be powered up in order of proximity from the Smart Wireless Gateway, beginning with the closest device to the Gateway. This will result in a simpler and faster network installation.

4. Close the housing cover and tighten. Ensure the power module cover is fully tightened to prevent moisture ingress. The lip of the polymer power module cover should be in contact with the surface of the polymer enclosure to ensure a proper seal. Do not over tighten.

3.0 Verify operation

Operation can be verified in four locations: by using the Field Communicator, at the Gateway via the Smart Wireless Gateway's integrated web server, via AMS™ Wireless Configurator, or with the wireless device's LCD display.

3.1 Field Communicator

If you are able to communicate to the wireless device via a Field Communicator, the power module is powering the device and working correctly. [Figure 5](#) shows how to connect a Field Communicator to a wireless device with either the black or green power module.

Figure 5. Field Communicator Connections

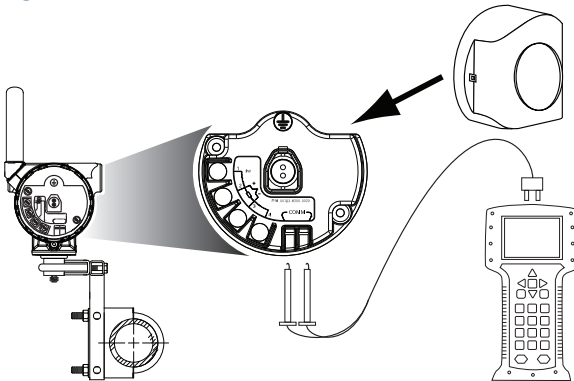
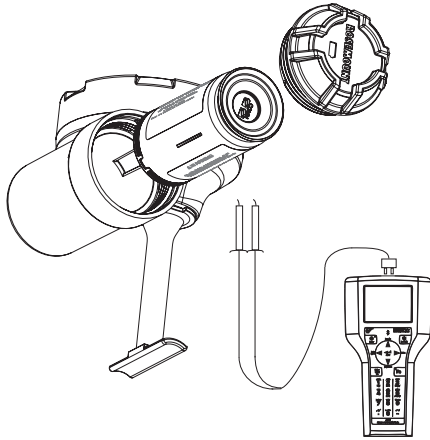

Figure 6. 475 Field Communicator

3.2 Smart Wireless Gateway

If the wireless device was configured with the Network ID and Join Key, and sufficient time has passed for network polling, the transmitter will be connected to the network. To verify device operation and connection to the network with the Smart Wireless Gateway's integrated web server, open the Smart Wireless Gateway's integral web interface and navigate to the Explorer page. If the wireless device has joined the network, the power module is functioning properly.

Note

It may take several minutes for the device to join the network.

3.3 AMS Wireless Configurator

When the device has joined the network, it will appear in the Wireless Configurator as illustrated below.

Figure 7. AMS Wireless Configurator

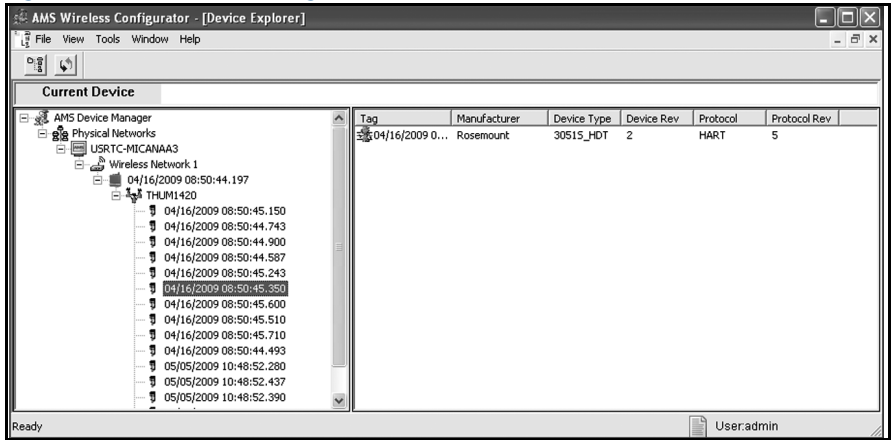

3.4 Wireless device LCD display

If the wireless device that you are connecting the power module to has an LCD display, it can be used to verify operation. When the power module is first connected to the wireless device, the LCD display will turn on for approximately 40 seconds. If the LCD display turns on after the power module is installed, the power module is functioning properly.

3.5 Troubleshooting

If the wireless device does not turn on after the power module is installed, the power module may be depleted. Change out the power module and see if the wireless device turns on. If not, refer to the troubleshooting section of the wireless device's manual.

4.0 Disposal/recycling of depleted power modules

1. Dispose in accordance with applicable laws and regulations in your country and state.
2. Disposal should only be performed by authorized professionals in accordance with applicable requirements for hazardous waste transportation and disposal.
3. Incineration should only be performed by trained professionals in authorized facilities.

Shipping regulations

Primary lithium batteries are regulated in transportation by the U.S. Department of Transportation, and are also covered by IATA (International Air Transport Association), ICAO (International Civil Aviation Organization), and ADR (European Ground Transportation of Dangerous Goods). It is the responsibility of the shipper to ensure compliance with these or any other local requirements. Please consult current regulations and requirements before shipping.

Handling considerations

Each black power module contains two “C” size primary lithium batteries. Each green power module contains one “D” size primary lithium battery.

Under normal conditions, the battery materials are self-contained and are not reactive as long as the batteries and the battery pack integrity are maintained. Care should be taken to prevent thermal, electrical, or mechanical damage. Contacts should be protected to prevent premature discharge.

Use caution when handling the power module. It may be damaged if dropped onto a hard surface. Battery hazards remain when cells are discharged.

Environmental considerations

As with any battery, local environmental rules and regulations should be consulted for proper management of spent batteries. If no specific requirements exist, recycling through a qualified recycler is encouraged. Consult the materials safety data sheet for battery specific information.

5.0 Product Certifications

Rev 1.0

5.1 European Directive Information

A copy of the EC Declaration of Conformity can be found at the end of the Quick Start Guide. The most recent revision of the EC Declaration of Conformity can be found at EmersonProcess.com/Rosemount.

5.2 Ordinary Location Certification from FM Approvals

As standard, the transmitter has been examined and tested to determine that the design meets the basic electrical, mechanical, and fire protection requirements by FM Approvals, a nationally recognized test laboratory (NRTL) as accredited by the Federal Occupational Safety and Health Administration (OSHA).

5.3 Installing in North America

The US National Electrical Code® (NEC) and the Canadian Electrical Code (CEC) permit the use of Division marked equipment in Zones and Zone marked equipment in Divisions. The markings must be suitable for the area classification, gas, and temperature class. This information is clearly defined in the respective codes.

USA

KF FM Intrinsically Safe (IS)

Certificate: 3042016

Standards: FM Class 3600 - 1998, FM Class 3610 - 2010, FM Class 3810 - 2005

Markings: IS CL I, DIV 1, GP A, B, C, D; CL II, DIV 1, GP E, F, G; Class III; Class 1, Zone 0 AEx ia IIC T4; (-40 °C □ T_a □ +70 °C)

(See [Table 1](#) or [Table 2](#) for parameters)

Special Condition for Safe Use (X):

1. Replacement of power module, see instructions for final product

Canada

KF CSA Intrinsically Safe

Certificate: 2430393

Standards: CAN/CSA C22.2 No. 0-M91, CSA Std C22.2 No. 157-92

Markings: Intrinsically Safe Class I, Division 1, Groups A, B, C, and D T3C I

(T_a ≤ +70 °C) Warning - refer to QIG 825-0100-4701 for Safe I.S. Use

(See [Table 1](#) or [Table 2](#) for parameters)

Special Condition for Safe Use (X):

1. The power modules are certified as components for use in intrinsically safe products where the suitability/combination of use in the final assembly shall be subjected to CSA acceptance. The final assembly must incorporate all protection features necessary for batteries in accordance with applicable standards of the final intrinsically safe application.

Europe

KF ATEX Intrinsic Safety

Certificate: Baseefa11ATEX0042X

Standards: EN 60079-0: 2012, EN 60079-11: 2012

Markings:  II 1 G Ex ia IIC T4 Ga, T4(-55 °C ≤ T_a ≤ +70 °C)

 II 1 G Ex ia IIC T5 Ga, T5(-55 °C ≤ T_a ≤ +40 °C)

(See [Table 1](#) or [Table 2](#) for parameters)

Special Condition for Safe Use (X):

1. The plastic enclosure of the Rosemount 701P SmartPower Power Modules may constitute a potential electrostatic ignition risk and caution should be used when being handled.

Note

This condition of use does not apply after a power module is installed within a wireless transmitter enclosure.

International

KF IECEx Intrinsic Safety

Certificate: IECEx BAS 11.0026X

Standards: IEC 60079-0: 2011, IEC 60079-11: 2011

Markings: Ex ia IIC T4/T5 Ga, T4(-55 °C ≤ T_a ≤ +70 °C), T5(-55 °C ≤ T_a ≤ +40 °C)

Special Condition for Safe Use (X):

1. The plastic enclosure of the Rosemount 701P SmartPower Power Modules may constitute a potential electrostatic ignition risk and caution should be used when being handled.

Note

This condition of use does not apply after a power module is installed within a wireless transmitter enclosure.

EAC - Belarus, Kazakhstan, Russia

KF Technical Regulation Customs Union (EAC) Intrinsic Safety

Certificate: RU C-US.Gb05.B.00281

Markings: 0Ex ia IIC T4/T5 Ga X

T4 (-55 °C ≤ T_a ≤ +70 °C)

T5 (-55 °C ≤ T_a ≤ +40 °C)



Table 1. 701BK

Safety parameters	
U_o	7.8 V
I_o	2.16 A
P_o	0.83 W
C_o	3.0 μ F
L_o	7.6 μ H

Table 2. 701PGN

Safety parameters	
U_o	3.9 V
I_o	2.78 A
P_{ot}	2.71 W
C_o	100 μ F
L_o	4.6 μ H

Figure 8. Rosemount 701P Declaration of Conformity

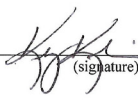
	<h1>EU Declaration of Conformity</h1> <p>No: RMD 1085 Rev. B</p>	
<p>We,</p> <p>Rosemount, Inc. 8200 Market Boulevard Chanhassen, MN 55317-9685 USA</p> <p>declare under our sole responsibility that the product,</p> <p>Rosemount 701P SmartPower Power Module</p> <p>manufactured by,</p> <p>Rosemount, Inc. 8200 Market Boulevard Chanhassen, MN 55317-9685 USA</p> <p>to which this declaration relates, is in conformity with the provisions of the European Union Directives, including the latest amendments, as shown in the attached schedule.</p> <p>Assumption of conformity is based on the application of the harmonized standards and, when applicable or required, a European Union notified body certification, as shown in the attached schedule.</p>		
 _____ (signature)		Vice President of Global Quality _____ (function)
Kelly Klein _____ (name)		19 Apr 2016 _____ (date of issue)
Page 1 of 3		



EU Declaration of Conformity

No: RMD 1085 Rev. B

EMC Directive (2004/108/EC) *This directive is valid until 19 April 2016*

EMC Directive (2014/30/EU) *This directive is valid from 20 April 2016*

Harmonized Standards:
EN 61326-1: 2013

ATEX Directive (94/9/EC) *This directive is valid until 19 April 2016*

ATEX Directive (2014/34/EU) *This directive is valid from 20 April 2016*

Baseefa11ATEX0042X – Intrinsic Safety Certificate

Equipment Group II, Category 1 G

Ex ia IIC T4/T5

Other Standards:

EN 60079-0:2009 (A review against EN60079-0: 2012, which is harmonized, shows no significant changes relevant to this equipment so EN 60079-0: 2009 continues to represent "State of the Art")

EN 60079-11: 2007 (A review against EN60079-11: 2012, which is harmonized, shows no significant changes relevant to this equipment so EN 60079-11: 2007 continues to represent "State of the Art")



EU Declaration of Conformity

No: RMD 1085 Rev. B



ATEX Notified Body

SGS Baseefa Limited [Notified Body Number: 1180]
Rockhead Business Park
Staden Lane
Buxton, Derbyshire
SK17 9RZ United Kingdom

ATEX Notified Body for Quality Assurance

SGS Baseefa Limited [Notified Body Number: 1180]
Rockhead Business Park
Staden Lane
Buxton, Derbyshire
SK17 9RZ United Kingdom

含有China RoHS管控物质超过最大浓度限值的部件型号列表 Rosemount 701P
List of Rosemount 701P Parts with China RoHS Concentration above MCVs

Part Name 部件名称	Hazardous Substances / 有害物质					
	Lead 铅 (Pb)	Mercury 汞 (Hg)	Cadmium 镉 (Cd)	Hexavalent Chromium 六价铬 (Cr +6)	Polybrominated biphenyls 多溴联苯 (PBB)	Polybrominated diphenyl ethers 多溴联苯醚 (PBDE)
电子组件 Electronics Assembly	X	O	O	O	O	O
电池组件 Battery Assembly	X	O	O	O	O	O

本表格系依据SJ/T11364的规定而制作。

This table is proposed in accordance with the provision of SJ/T11364.

O: 意为该部件的所有均质材料中该有害物质的含量均低于GB/T 26572所规定的限量要求。

O: Indicate that said hazardous substance in all of the homogeneous materials for this part is below the limit requirement of GB/T 26572.

X: 意为在该部件所使用的的所有均质材料里，至少有一类均质材料中该有害物质的含量高于GB/T 26572所规定的限量要求。

X: Indicate that said hazardous substance contained in at least one of the homogeneous materials used for this part is above the limit requirement of GB/T 26572.



Global Headquarters

Emerson Process Management

6021 Innovation Blvd.
Shakopee, MN 55379, USA
+1 800 999 9307 or +1 952 906 8888
+1 952 949 7001
RFQ.RMD-RCC@EmersonProcess.com

North America Regional Office

Emerson Process Management

8200 Market Blvd.
Chanhassen, MN 55317, USA
+1 800 999 9307 or +1 952 906 8888
+1 952 949 7001
RMT-NA.RCCRFQ@Emerson.com

Latin America Regional Office

Emerson Process Management

1300 Concord Terrace, Suite 400
Sunrise, FL 33323, USA
+1 954 846 5030
+1 954 846 5121
RFQ.RMD-RCC@EmersonProcess.com

Europe Regional Office

Emerson Process Management Europe GmbH

Neuhofstrasse 19a P.O. Box 1046
CH 6340 Baar
Switzerland
+41 (0) 41 768 6111
+41 (0) 41 768 6300
RFQ.RMD-RCC@EmersonProcess.com

Asia Pacific Regional Office

Emerson Process Management Asia Pacific Pte Ltd

1 Pandan Crescent
Singapore 128461
+65 6777 8211
+65 6777 0947
Enquiries@AP.EmersonProcess.com

Middle East and Africa Regional Office

Emerson Process Management

Emerson FZE P.O. Box 17033,
Jebel Ali Free Zone - South 2
Dubai, United Arab Emirates
+971 4 8118100
+971 4 8865465
RFQ.RMTMEA@Emerson.com



Linkedin.com/company/Emerson-Process-Management



Twitter.com/Rosemount_News



Facebook.com/Rosemount



Youtube.com/user/RosemountMeasurement



Google.com/+RosemountMeasurement

Standard Terms and Conditions of Sale can be found at

www.Emerson.com/en-us/pages/Terms-of-Use.aspx

The Emerson logo is a trademark and service mark of Emerson Electric Co.

AMS, SmartPower, Rosemount, and the Rosemount logotype are trademark of Emerson Process Management.

HART is a registered trademark of the FieldComm Group.

National Electrical Code is a registered trademark of National Fire Protection Association, Inc.

All other marks are the property of their respective owners.

© 2016 Emerson Process Management. All rights reserved.