



Committing to the future

testo 6651
testo 6681

Industrial Measurement Transmitters for Critical Climate

NEW!

%RH

°C/°F

°C_{td}

°F_{td}

g/m³

g/kg

J/g

hPa



The basis of stability - the Testo humidity sensor

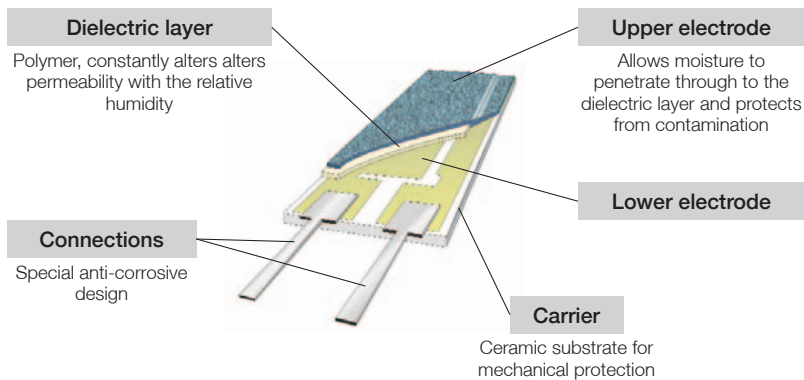

The Testo humidity sensor: the central component of high-quality humidity measurement transmitters

For years, Testo has been the first choice when it comes to high-quality measurement transmitters for drying processes and critical climate.

On the basis of our years of experience, the sensor and signal processing concept has been completely reworked.

Whether high humidity, corrosive media or constant cleanroom conditions: the Testo humidity measurement transmitters testo 6651 and testo 6681 offer optimum accuracy and long-term stability.



Long-term stable, condensation-proof and based on international standards (ILAC / PTB / NIST etc.): the Testo humidity sensor



Country	1 Germany	2 France	3 USA	4 Italy	5 England	6 Spain	7 Japan	8 Korea	9 China	10 Germany
Institute	PTB	CETIAT	NIST	IMGC	NPL	INTA	JQA	KRISS	NRCCRM	PTB
Arrival	04/96	10/96	12/96	07/97	09/98	10/98	03/99	05/00	10/00	03/01
Departure	08/96	10/96	05/97	10/97	09/98	10/98	04/00	09/00	12/00	08/01

Inter-laboratory test

Every specialist around the world knows and values it - the Testo inter-laboratory test. With it, Testo has impressively proven that very different national calibration laboratories (with their widely differing test procedures), have confirmed the Testo humidity sensor's highest accuracy.

What exactly happened? After five years travelling around the world, the Testo humidity sensors, which had been exposed to very different loads, all showed accuracies of better than ± 1 %RH!

This would already be an excellent result for a single test! With regard to a time series of five years, it testifies to a quality which is of highest priority to all users worldwide: first class long-term stability!

The basis of stability - the Testo humidity sensor

High humidity measurement - testo 6614

Humidity measurement in the high humidity range is among the most difficult measurement tasks. Unstable measurement values, delayed signal reaction, and sometimes also sensor corrosion are no rarity, if a special solution is not used

For these applications, Testo has developed a special, heated humidity sensor with the testo 6614. A microclimate which is 5 Kelvin above the process conditions is thus created inside the filter. The considerably lower humidity in the microclimate greatly improves the sensor reaction as well as noticeably reducing the likelihood of corrosion.

Parallel to the heated humidity sensor, the testo 6614 also has an additional temperature probe. This measures the actual process temperature; on this basis the correct process humidity is calculated in the microprocessor of the measurement transmitter, and displayed.



Trace humidity measurement - testo 6615

Humidity measurement in the lowest humidity range is also very demanding. If "normal" polymer humidity sensors are used here, the error, measured in dewpoint degrees, soon shows high values.

For the demanding measurement of trace humidity, Testo has developed the testo 6615, which has an integrated trace humidity self-adjustment. The smallest discrepancies are corrected cyclically here, up to trace humidities of -60° dewpoint!

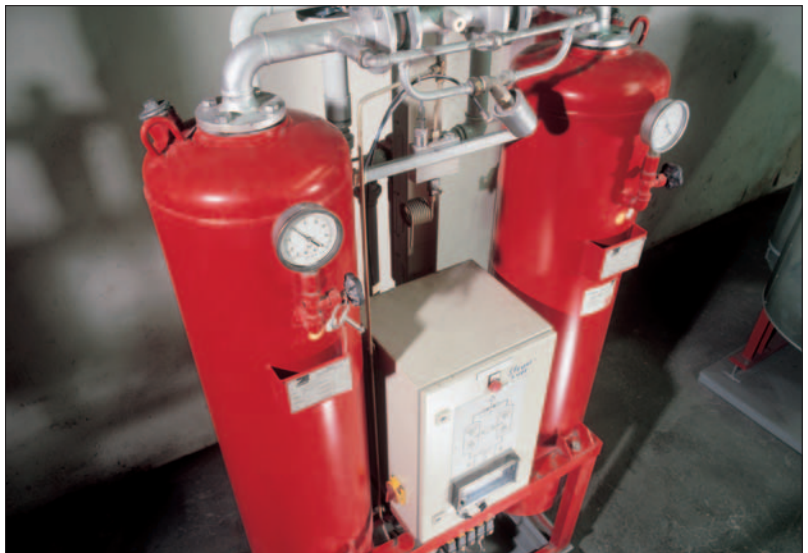

Humidity measurement in corrosive media – testo 6617

Humidity measurement in corrosive media is often accompanied by a short useful life of the sensor. For this problem too, Testo has developed a ground-breaking innovation: cover electrode monitoring.

Thanks to this measure, the first signs of corrosion are detected and reported early. This early warning allows the measurement probe to be exchanged before the measurement is false or even interrupted. This guarantees optimum system availability!



Overview of the product series testo 6651 and 6681

The two new humidity measurement transmitters from Testo, the series testo 6651 and testo 6681, are positioned in the middle to upper performance range. They are designed for the monitoring of critical climate in process engineering and also in compressed air technology. The demanding measurement is realized with the further developed Testo humidity sensor, with its well-known and highly-valued long-term stability. Unmatched state-of-the-art technology in humidity measurement, with solutions for highest accuracy as well as for special applications (high humidity, humidity in H₂O₂, trace humidity etc.) is provided.

Both instrument series present many new features, among them world innovations such as a professional bus interface in the humidity measurement transmitter testo 6681

It is a completely newly developed generation of instruments, which in particular offers solutions for safe and service-friendly use, meaning high reliability and operational security for industry:

- exchangeable probes
- early warning reports
- variable possibilities for adjustment

In addition, they also continue to use already existing technology such as the external interface for communication, for example for the parameterization and adjustment software P2A from Testo.

The overview on the next page shows a comparison of the two models, followed by a detailed description of the individual models.

Measurement transmitter series



Measurement transmitter testo 6681 with and without display



Measurement transmitter testo 6651 with and without display

Overview of the product series testo 6651 and 6681



Model	testo 6651	testo 6681	Performance
Applications	Climate technology and industry: critical climate, cleanrooms	Industry: critical climate, cleanrooms, drying processes, high humidity, trace humidity, humidity in H ₂ O ₂ environment etc.	

		testo 6651	testo 6681
Measuring range	Humidity	0 to 100 %RH (no high humidity processes)	0 to 100 %RH
	Temperature (dependent on probe)	-20 to +120 °C	-20 to +180 °C
Accuracy at +25 °C (+77 °F)*	Humidity	±(1,7 %RH + 0,007 x mv)	up to ±(1 %RH + 0,007 x mv)
	Temperature*	Pt100 Class A ±0,2 °C / 0,38 °F	Pt100 1/3 Class B ±0,15 °C / 0,27 °F
Measurement parameters		°C/°F, %rF/%RH, °C _{td} /°F _{td}	°C/°F, %rF/%RH, °C _{td} /°F _{td} , °C _{tpd} /°F _{tpd} , g/m ³ /gr/ft ³ , g/kg/gr/lb, enthalpy/°Ctw, °Ftw, inch, H ₂ O, ppm(vol), % Vol Probe 6615 only: °C _{tpd} /°F _{tpd} for H ₂ O ₂ -applications: °Ctm/°Ftm
Signal outputs		4 to 20 mA, 2-wire 0/4 to 20 mA, 4-wire 0 to 1/5/10 Volt, 4-wire	4 to 20 mA, 2-wire (not for testo 6614/6615) 0/4 to 20 mA, 4-wire 0 to 1/5/10 Volt, 4-wire
Mounting variants		Wall probe testo 6601 Duct probe testo 6602/6603 Cable probe testo 6604/6605	Wall probe testo 6611 Duct probe testo 6612 Cable probe testo 6613/6614/6615/6617
max. cable length		5 m	10 m
Housing		ABS, plastic, IP65	Metal, IP65
Interfaces		digital Testo (for P2A software or testo 400/650)	digital Testo professional bus (optional intermediary layer)
Special features		4 relays, optional early warning system (via display or relay collective alarm)	Special probe versions for <ul style="list-style-type: none"> • Temperature ranges up to +180 °C (+324 °F) • Trace humidity testo 6615 • High humidity testo 6614 • Self-diagnosis testo 6617 4 relays, optional early warning system (via display, relay collective alarm or professional bus)

*Other accuracies apply for the wall probe with 70 mm length in combination with a current output (P07):
Operation: with 2 channels at 12 mA, without display illumination, relay off, additional measurement inaccuracy to above data at +25 °C (+77 °F), humidity ±2.5 %RH, temperature ±1 °C (1.8 °F)

P2A software for testo 6651 and testo 6681

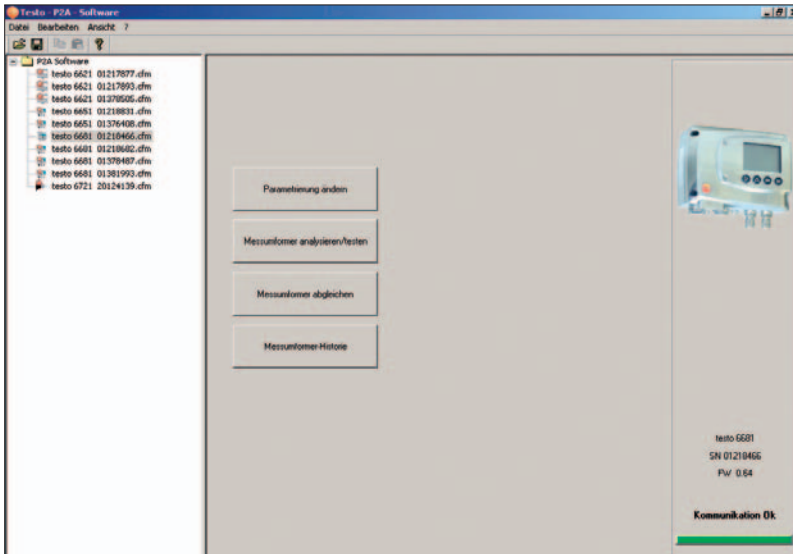

Software for parameterization, adjustment and analysis

Optimum procedures from the point of view of the user – that is the central idea of the new measurement transmitter software “P2A” from Testo. The name stands for

P – Parameterization

A – Adjustment

A – Analysis

All new (and future) Testo measurement transmitters communicate with this software, the connection of the PC (via external or easily accessible interfaces) being extremely easy. The software only needs to be bought once – all further updates are free of charge!

An additional advantage is the supply of the measurement transmitter via USB. Parameterization or analysis can thus be carried out without the need for wiring – e.g. at a desk or in a workshop.

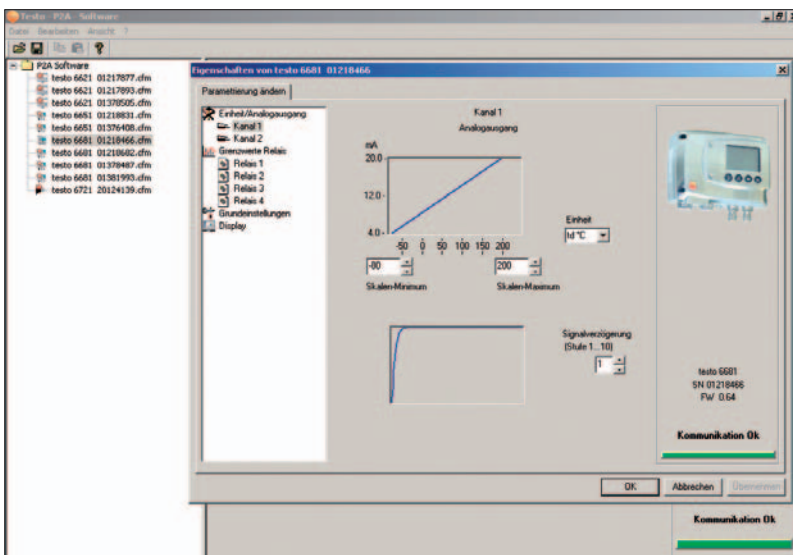

P2A software: parameterization and data management

In the course of commissioning, the scaling of the analog channels, the limit values of the (optional) relays, the signal damping etc. are set. The P2A software supports all these procedures with convenient menus which are extensively supported graphically.

Are several measurement sites intended to have the same parameters? No problem - the parameter sets can be transferred by simple “drag and drop”. This saves considerable time in larger installations.

P2A software: adjustment

In addition to the 1-point adjustment (offset) and the 2-point adjustment (with the help of the saline solution pots or a humidity generator), the P2A software supports the analog adjustment of each analog channel. Using a precise multimeter, the entire measurement chain (including the digital-analog converter) can thus be adjusted. Unique: adjustment histories present in detail who carried out which adjustment when, and at which reference values. This provides uninterrupted documentation, independently of whether the adjustments were carried out with (any) P2A software, the operating menu or the adjustment buttons.

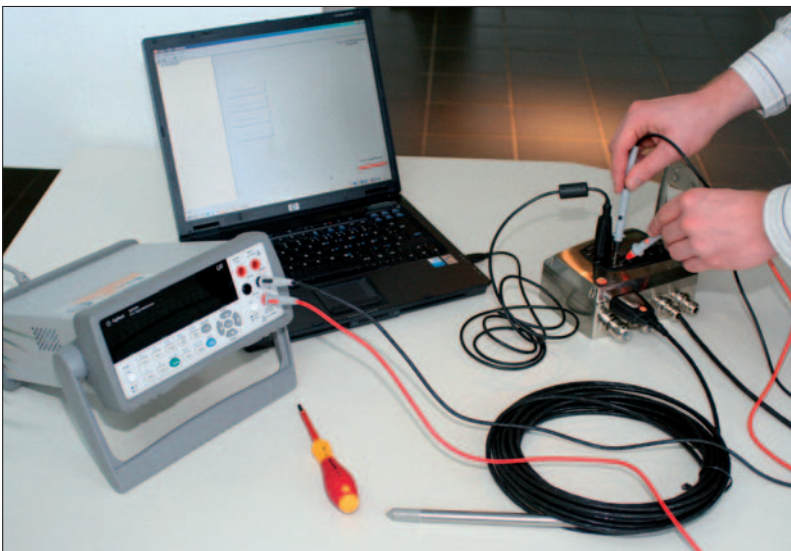

P2A software for testo 6651 and testo 6681

P2A software: analysis and histories

Ideal for the localization of errors and optimization: the analysis tools of the P2A software. They allow the analog and relay signals to be tested, and the min./max. values to be displayed.

How can you look into the past? With the help of an operational hour counter, the measurement transmitter stores occurring reports with a time stamp. This report history is displayed in the P2A software and provides important information on all events.

The P2A software has five such histories.

- Parameterization history (what was set when?)
- Report history (which errors, warnings and status reports occurred)
- History of 1-point adjustments
- History of 2-point adjustments
- History of analog adjustments

As all these procedures are stored in the measurement transmitter (with operational hour counter), a sound analysis can be made with the help of any P2A software.

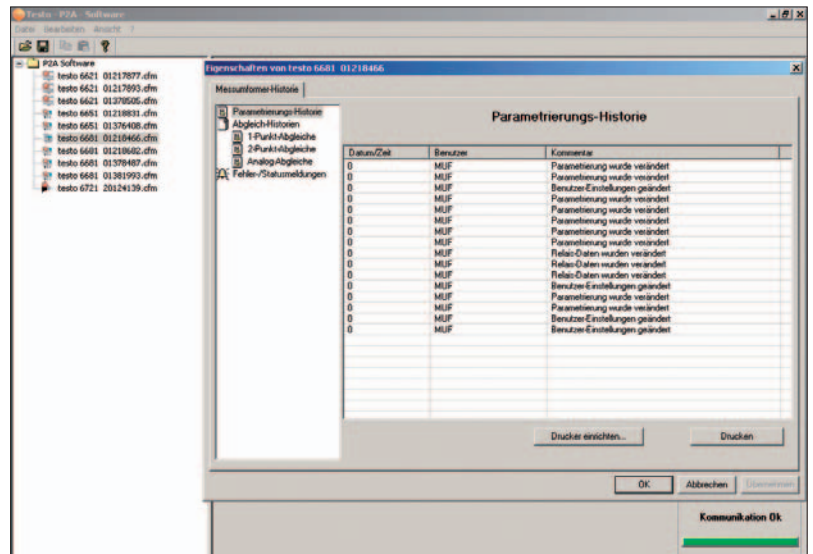

Common features + benefits testo 6651 and testo 6681



Display and operating menu

The optional display has an extremely convenient operating menu. With the help of four operating buttons, almost all operations can be carried out which can be conducted using the P2A software. Commissioning, adjustment and analysis are thus possible completely without a PC - simply on site!

The display not only presents the measurement values and relay status clearly, but also guides the user safely through the operating menu thanks to a clear-text line. A password protects against unauthorized operation. A cover for the buttons can also be installed.

And last but not least: The clear-text can be selected in six languages - optimum for your systems at home and abroad.

Digital probes

The humidity probe in the models testo 6651 and 6681 can be easily exchanged by hand. A readjustment with the measurement transmitter itself is not necessary, since the probe series testo 6600 used in the humidity measurement transmitter testo 6651 not only has a purely digital interface to the measurement transmitter, it is also completely calibrated and adjusted.

Uplug probe 1, plug in probe 2 - continue measuring!

At the same time, Testo fulfils the highest demands, for example those of the pharmaceutical industry. Each probe has its own serial number, a store for the adjustments carried out with it, and its own operational hour counter. The visualizes (via the measurement transmitter's operating menu or the P2A software) how long the probe has already been in use, and which settings have been carried out on it (see also P2A software):

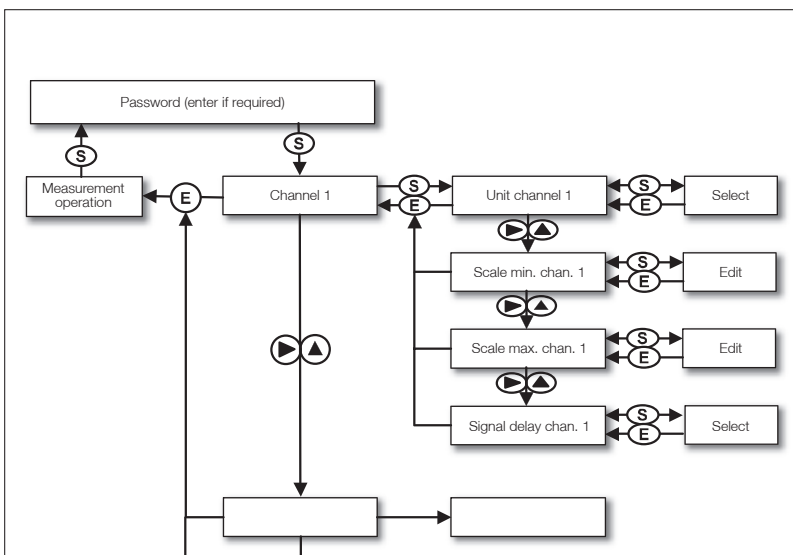

Common features + benefits testo 6651 and testo 6681

Direct on-site adjustment with the testo 400

A regular adjustment is indispensable for all demanding humidity measurement - although the highly stable Testo sensors mean that a correction is often not necessary even after three or four years.

The important thing for the user is that the process (the air conditioning system, pasta drying etc.) is not interrupted by the adjustment procedure. And transporting a laptop/PC to the measurement site is not always feasible.

For this reason, Testo has equipped the testo 6651 with an easily accessible interface. Using the adapter 0554 6022, the reference measuring instrument test 400 or 650 (with a precision humidity probe) can be directly connected to the measurement transmitter. In the display of the hand instrument, the humidity and temperature values of the two instruments are shown opposite each other. If the discrepancies are too high, a few touches of a button are sufficient to adjust the testo 6651 (1-point adjustment). After only a few moments, you are ready to carry on to the next measurement site.



1-point adjustment on site with the portable instrument testo 400 or testo 650 with precision humidity probe and adjustment adapter

Adjustment via operating menu or P2A software

In addition to the numerous possibilities for calibrating the probe together with the measurement transmitter locally, (cf. P2A software and operating menu), it is possible, thanks to the digital probe series testo 6600, to leave the measurement transmitter on site and to exchange only the probe and calibrate it in a laboratory.

Companies with internal calibration laboratories install at least one testo 6651 measurement transmitter in the laboratory and use it as an adjustment basis for various probes. After adjustment, the probes - or others of the same design - are reconnected at the original measurement site. Thanks to the probe serial number, it is always possible to trace (for example with the P2A software), which probe was connected when to a measurement transmitter, and how it was adjusted (1 or 2-point adjustment).

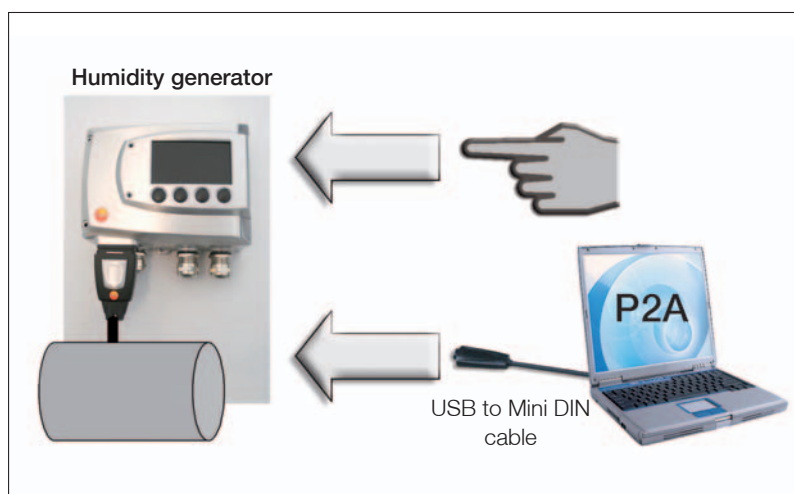

Adjustment via operating menu or testo P2A software

testo 6651 – features + benefits



Designed for practice

The emphasis in the construction of testo 6651 and testo 6681 was practicability. Here a few examples:

- Adjustment buttons, test points (see below) and interface should be easily accessible for the specialist, but not for others. This was the reason for designing the “**service cover**” which frames the display.
- **Test points:** do the analog outputs need to be tested when commissioning the instrument? Are analog adjustments to be made at a later date? Instead of disconnecting already existing wiring (and opening the housing), test points (see photo at left, e.g. Ch.1+/Ch.1-) were positioned under the service cover, which allow easy access to the analog signals.
- **Wiring compartment:** Which practitioner is not often frustrated by the minimal space afforded by measurement transmitter manufacturers for wiring? For this reason, Testo has designed a separate wiring compartment with plenty of space. The practitioner will appreciate it.

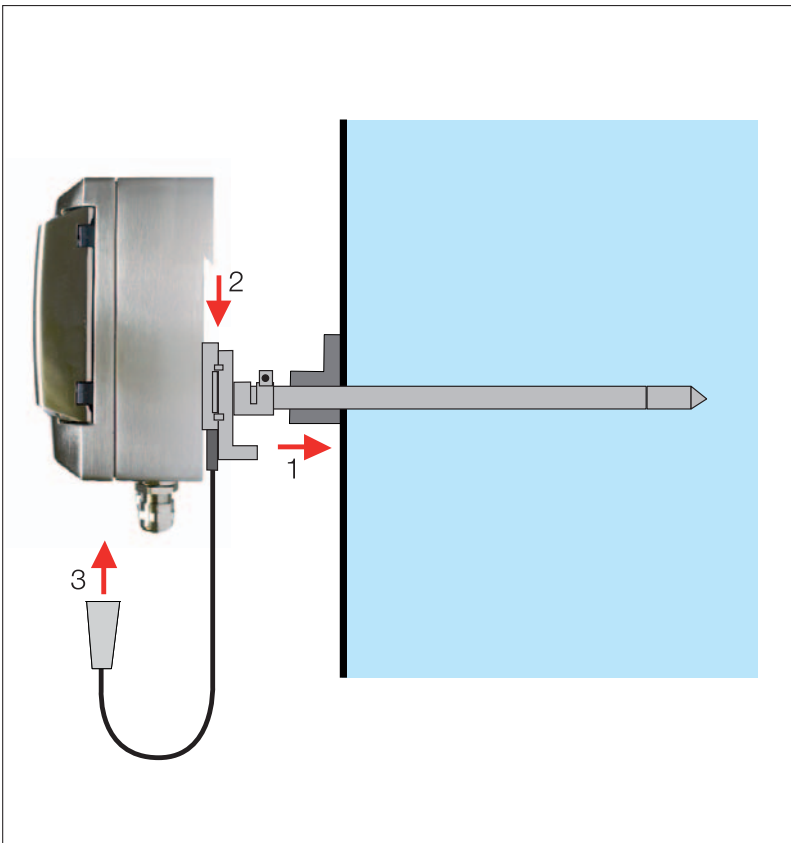

Duct version with exchangeable probe

For many users, the duct version, in which the probe is classically attached to the rear wall of the measurement transmitter, is the best solution. The measurement transmitter must not be mounted separately, but is held in position by the probe (1).

With the testo 6602/6603 (for testo 6651) as well as the testo 6612 (for testo 6681), Testo has succeeded in making this version available for the first time on the world market for exchangeable digital probes. The intelligent probe-cable construction means that the measurement transmitter is simply pushed over the end of the probe (2), and the digital probe plug is then plugged in (3).

testo 6651 – features + benefits

Integrated relays (optional)

Thanks to the four power relays (up to 256 VAC, 3A), assemblies of the air conditioning system can be directly switched without the “detour” via a control. At the same time, the relays can be used for local alarming or for reporting limit value violations to a superordinate system.

And not least, the person responsible for the system can be called to the measurement site in time with the help of a “collective alarm” (cf. self-monitoring”).

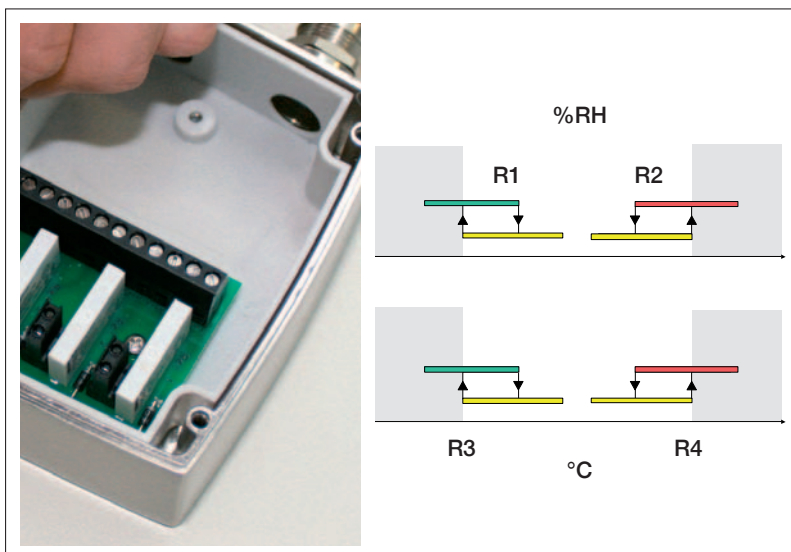

Self-monitoring

The testo 6651 constantly monitors itself: its voltage supply, when 100 %RH is reached, any drift in 2-point adjustment etc.

The reports resulting from this are not only stored with an operational hours stamp - for later analysis - and shown in the display!

With the help of the optional relays, these reports can also be given out as a “collective alarm”. The person responsible - working as a team with the testo 6651 - can thus always ensure optimum system availability!



testo 6651 – the humidity measurement transmitter for critical climate applications

Not all measurement problems in air conditioning technology can be solved with “simple” measurement transmitters like the testo 6621. Special challenges are mastered by the testo 6651.

- The probe should be digital and exchangeable. In the testo 6651, even the duct version fulfils this – a world innovation!
- Higher accuracies are required, especially with regard to use over years
- The humidity parameter dewpoint ($^{\circ}\text{C}_{\text{td}}/^{\circ}\text{F}_{\text{td}}$) is to be used, for example in processes in which it is of highest priority that the temperature does not fall below the dewpoint
- Assemblies are to be controlled from the instrument (optional integrated relays)
- Commissioning, adjustment and analysis are to be possible directly in the instrument without software (optional display/operating menu)
- Changes of parameter, adjustments and reports are to be stored in the instrument – with operating hour stamp

This and other features make the testo 6651 the first choice for demanding climate technology, as well as in pasta drying systems, maturation chambers for charcuterie and similar applications.



Pasta drying is carried out by measuring humidity

Overview of the product range: measurement transmitters testo 6651 and digital probes 6600

Whether the decision is made in favour of a testo 6651 or a testo 6681 depends above all on the choice of probe, in addition to the question of the housing material (6681: metal housing), and the humidity parameters or signals to be used (e.g. professional bus only in testo 6681). In general, the measuring range 0 to 100 %RH applies, although for continuous high humidity the testo 6614 is recommended.

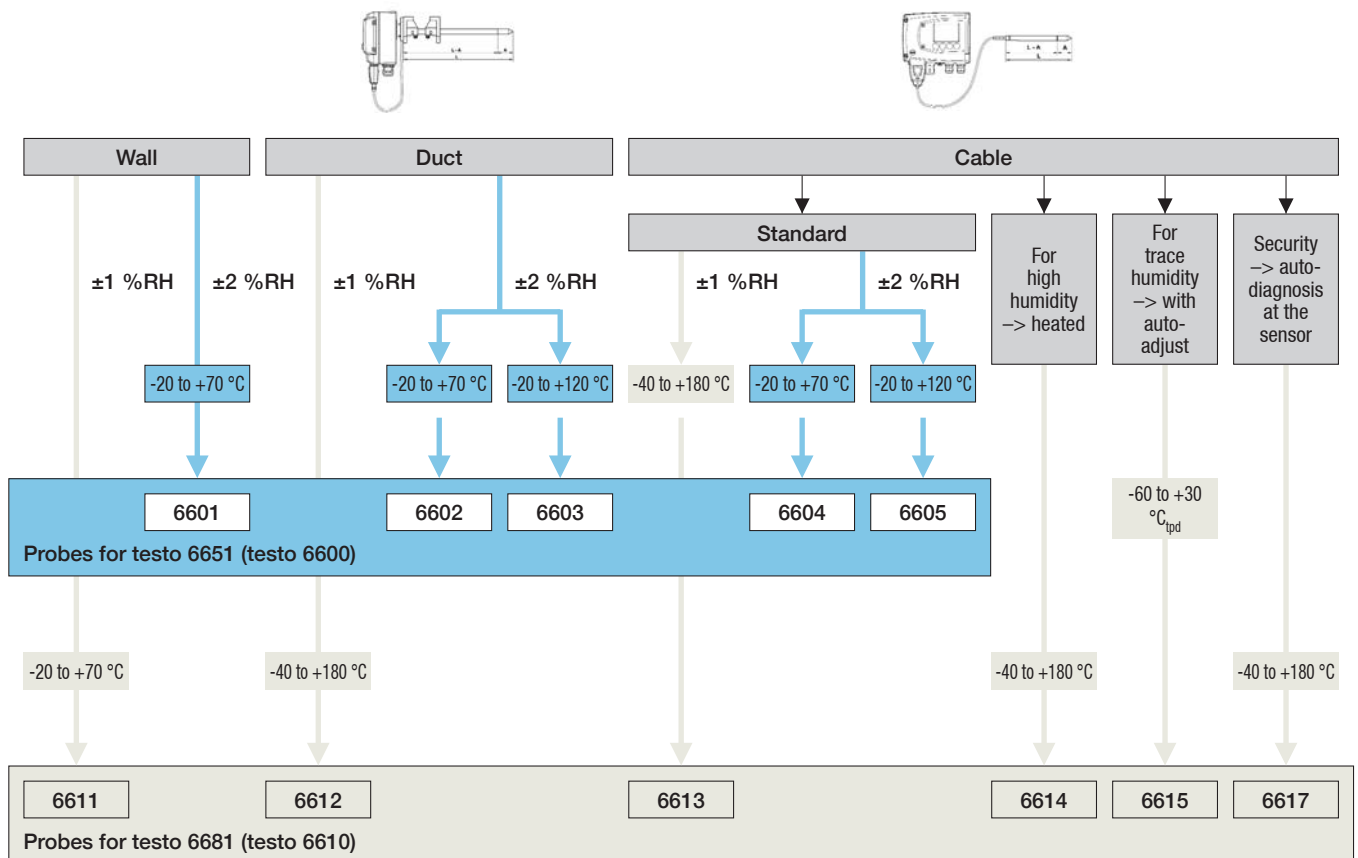

Order codes measurement transmitter testo 6651

The humidity measurement transmitter for critical climate (testo 6651) is generally customer-specifically configured, adjusted and delivered. Please select the measurement transmitter you require step by step.

0555 6651 **A01** Bxx Cxx Dxx Exx Fxx Gxx Hxx Ixx Jxx Kxx

- B01 4 to 20 mA (2-wire, 24 VDC), not possible with relays
- B02 0 to 1 V (4-wire, 24 VAC/DC)
- B03 0 to 5 V (4-wire, 24 VAC/DC)
- B04 0 to 10 V (4-wire, 24 VAC/DC)
- B05 0 to 20 mA (4-wire, 24 VAC/DC)
- B06 4 to 20 mA (4-wire, 24 VAC/DC)

- C00 Without display
 - C02 With display / English
 - C03 With display / German
 - C04 With display / French
 - C05 With display / Spanish
 - C06 With display / Italian
 - C07 With display / Japanese
- } Clear-text language

- D01 Cable input M16 (relay: M20)
- D02 Cable input NPT 1/2"
- D03 Cable contact via via M plug connection

- F01 %RH / min / max
 - F02 °C / min / max
 - F03 °F / min / max
 - F04 °C_{td} / min / max
 - F05 °F_{td} / min / max
- } Channel 1* =

- G01 %RH / min / max
 - G02 °C / min / max
 - G03 °F / min / max
 - G04 °C_{td} / min / max
 - G05 °F_{td} / min / max
- } Channel 2* =

- H00 Without relay
 - H01 4 relay outputs, limit value monitoring
 - H02 4 relay outputs, limit values channel 1 + collective alarm
- } not with code "B01"

- K01 IM German-English
- K02 IM French-English
- K03 IM Spanish-English
- K04 IM Italian-English
- K05 IM Dutch-English
- K06 IM Japanese-English
- K07 IM Chinese-English

Order example measurement transmitter testo 6651

Housing with display with menu in English

4 to 20 mA (2-wire)

Cable input M16/M20

Factory setting channel 1:

%RH with scaling min 0 %, max 100 %*

Factory setting channel 2:

°C with scaling min -10 °C, max 70 °C*

without relay

Instruction manual in German + English

→ **0555 6651 A01 / B01 / C02 / D01 / F01 / G02 / -10 / +70 / H00 / K01**

* The standard scaling is delivered without "min" and "max"

Ordering options probe range testo 6600

0555 6600 **Lxx** Mxx Nxx Pxx

L01	Probe 6601
L02	Probe 6602
L03	Probe 6603
L04	Probe 6604
L05	Probe 6605

M01	Sintered stainless steel filter
M02	Wire mesh protective cap
M03	Sintered Teflon filter
M04	Metal protective cap, open
M05	Plastic cap ABS, open

N00	Without cable (for probe 6601)
N01	Cable length 1 m (for probes 6604/6605)
N02	Cable length 2 m (for probes 6604/6605)
N05	Cable length 5 m (for probe 6605 only)
N23	Cable length, specially for duct versions (for probes 6602/6603)

Order example probe

Duct probe (-20 to +70 °C are sufficient)

Sintered stainless steel filter

Probe length 280 mm

→ **0555 6600 L02 / M01 / N23 / P28**

		L01	L02	L03	L04	L05
P07	Probe length 70 mm	X	-	-	-	-
P14	Probe length 140 mm	-	-	-	X	-
P20	Probe length 200 mm	X	-	-	-	X
P28	Probe length 280 mm	-	X	X	X	-
P50	Probe length 500 mm	-	-	-	-	X

Ordering procedure:

The measurement transmitter and the probes can be ordered independently of each other, (thanks to the digital probe interface), cf order examples above.

If the measurement transmitter and the probe order are to be assembled together, their order codes are combined in the distribution set 0563 6681

Technical data measurement transmitter 6651

GENERAL						
Housing	Plastic					
Dimensions	122 x 162 x 77 mm (without probe)					
Weight	0.62 kg (without probe)					
Display	2-line LCD with clear-text line (optional) and relay status display					
Resolution display	0.1 %RH / 0.1 °C					
Cable screw fitting	M 16 x 1.5 (2x) with inner diameter 4-8 mm M 20 x 1.5 (2x) with inner diameter 6-12 mm					
Probe connection	Digital plug-in connection					
Voltage supply	2-wire: 24 VDC ±10 % 4-wire: 20 to 30 VAC/DC, 200 mA max. current consumption					
Protection class	IP 65					
EMC	2004/108/EG					
Operating temperature housing	-40 to +70 °C, with display 0 to +50 °C					
Storage temperature	-40 to +80 °C					
Measurement parameters	Temperature in °C / °F Relative humidity %rF / %RH Dewpoint in °C _{td} / °F _{td}					
Measurement medium	Air, nitrogen, more on request: applicationsupport@testo.de					
SENSOR (more data see probes)						
Humidity	Testo humid. sensor, cap.					
Reproduceability	better than ±0.5 %RH					
Measurement inaccuracy %RH	cf. probe data					
Probes	6601	6602	6603	6604	6605	
Measuring range	Humidity	0 to 100 %RH				
	Temperature	-20 to +70 °C	-20 to +70 °C	-30 to +150 °C	-20 to +70 °C	-30 to +150 °C
	Dewpoint	-60 to +100 °C _{td} or -76 to +212 °F _{td}				
Reaction time without protective filter	t 90 max. 10 s					
ANALOG OUTPUT (uniform for all channels, specify when ordering)						
Quantity	2 channels (type analog signal uniform for both channels, specify when ordering)					
Current/accuracy	4 to 20 mA ±0.03 mA (2-wire) 0 to 20 mA ±0.03 mA (4-wire) 4 to 20 mA ±0.03 mA (4-wire) for heated sensor technology					
Voltage/accuracy	0 to 1 V ±1.5 mV (4-wire) 0 to 5 V ±7.5 mV (4-wire) 0 to 10 V ±15 mV (4-wire)					
Galvanic isolation	Galvanic isolation of the output channels (2-wire and 4-wire), isolation of supply from outputs (4-wire)					
Resolution	12 bit					
Maximum load	2-wire 12 VDC: 100 Ohm 24 VDC: 500 Ohm 30 VDC: 625 Ohm 4-wire 500 Ohm					
FURTHER OUTPUTS						
Relays	4 relays (free allocation to measurement channels or as collective alarm), up to 256 VAC / 3 A, NC/C/NO (optional)					
Digital output	Mini DIN for Testo P2A parameterization software and Testo portable instruments 400/650 (optional)					

Technical data probe range testo 6600

Model	testo 6601	testo 6602	testo 6603	testo 6604	testo 6605
Type	Wall	Duct	Duct	Cable	Cable
Application	Room climate probe wall mounting	Climate probe duct mounting	Process climate probe duct mounting for higher process temperatures	Climate probe with cable	Stainless steel process probe with cable for higher process temperatures
Measurement parameters	%rF/%RH, °C _{td} /°F _{td} , °C/°F				
Measuring range	Humidity	0 to 100 %RH			
	Temperature	-20 to +70 °C	-30 to +120 °C	-20 to +70 °C	-30 to +120 °C
Material	Probe shaft	Plastic ABS			Stainless steel
	Cable	FEP coated			
	Plug	Plastic ABS			
Measurement inaccuracy*	Humidity: (+25 °C)	±(1,7 %RH + 0,007 x mv)			
	Humidity: for deviations from ±25 °C	±0.02 %RH/K			
	Temperature: at +25 °C / +77 °F	±0.2 °C / 0.38 °F			
Reproduceability	Humidity	better than ±0.5 %RH			
Probe dimensions	Diameter	12 mm			
	Probe shaft length L	70/200 mm	280 mm	140/280 mm	200/500 mm
Cable length	-	specially for duct versions		1/2 m	1/2/5 m
Pressure tightness	without	PN 1 (probe tip)			PN 10 (probe tip) PN 3 (probe end)
Drawings		testo 6651 Measurement transmitter testo 6651	Duct probe testo 6602/6603	Measurement transmitter testo 6651	Cable probe testo 6604/6605

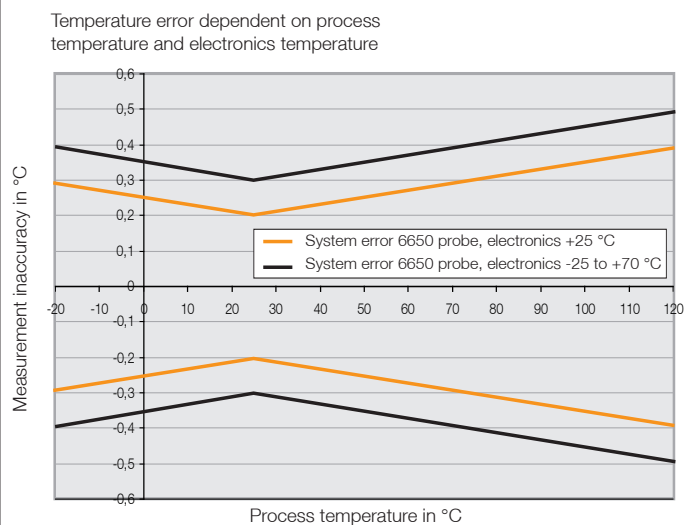
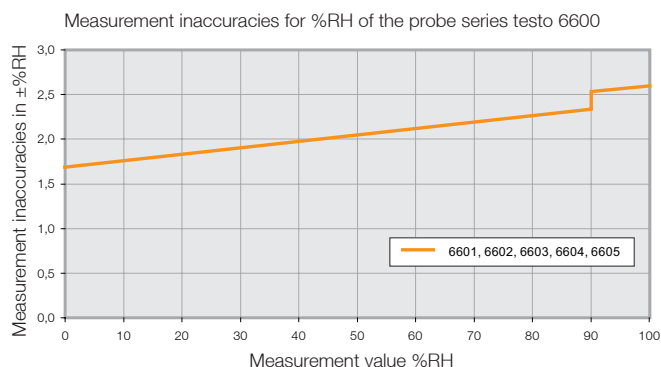

*Other accuracies apply for the wall probe with 70 mm length in combination with a current output (P07):

Operation: with 2 channels at 12 mA, without display illumination, relay off, additional measurement inaccuracy to above data at +25 °C (+77 °F), humidity ±2.5 %RH, temperature ±1 °C (1.8 °F)

testo 6681 – the industrial humidity measurement transmitter

Industrial humidity measurement requires absolute professionalism. Not only in the running of the system, but also in the measurement technology used. The industrial humidity measurement transmitter testo 6681 fulfils the highest demands.

Over and above the features and benefits of the testo 6651 already described above (digital probes, P2A software etc.), the testo 6681 has a number of additional features, which the practitioner will appreciate.

- **Accuracy**, up to ± 1 %RH
- **Preventative maintenance** via the early warning probe testo 6617
- A number of **humidity parameters**, such as absolute humidity and enthalpy etc.
- An absolutely robust **metal housing**
- A **trace humidity** (testo 6615) with auto-adjustment and high accuracy up to -60 °C_{tpd}
- A **high humidity probe** (testo 6614), stable even in continuous high humidity processes
- The field bus connection via **Profibus-DP**, a world innovation in humidity measurement

These and other reasons make testo 6681 the first choice in cleanroom technology, in drying technology, trace humidity and compressed air processes and demanding air conditioning technology.



Overview of the product range: measurement transmitters testo 6681 and digital probes 6610

Whether the decision is made in favour of a testo 6651 or a testo 6681 depends above all on the choice of probe, in addition to the question of the housing material (6681: metal housing), and the humidity parameters or signals to be used (e.g. professional bus only in testo 6681). In general, the measuring range 0 to 100 %RH applies, although for continuous high humidity the testo 6614 is recommended.

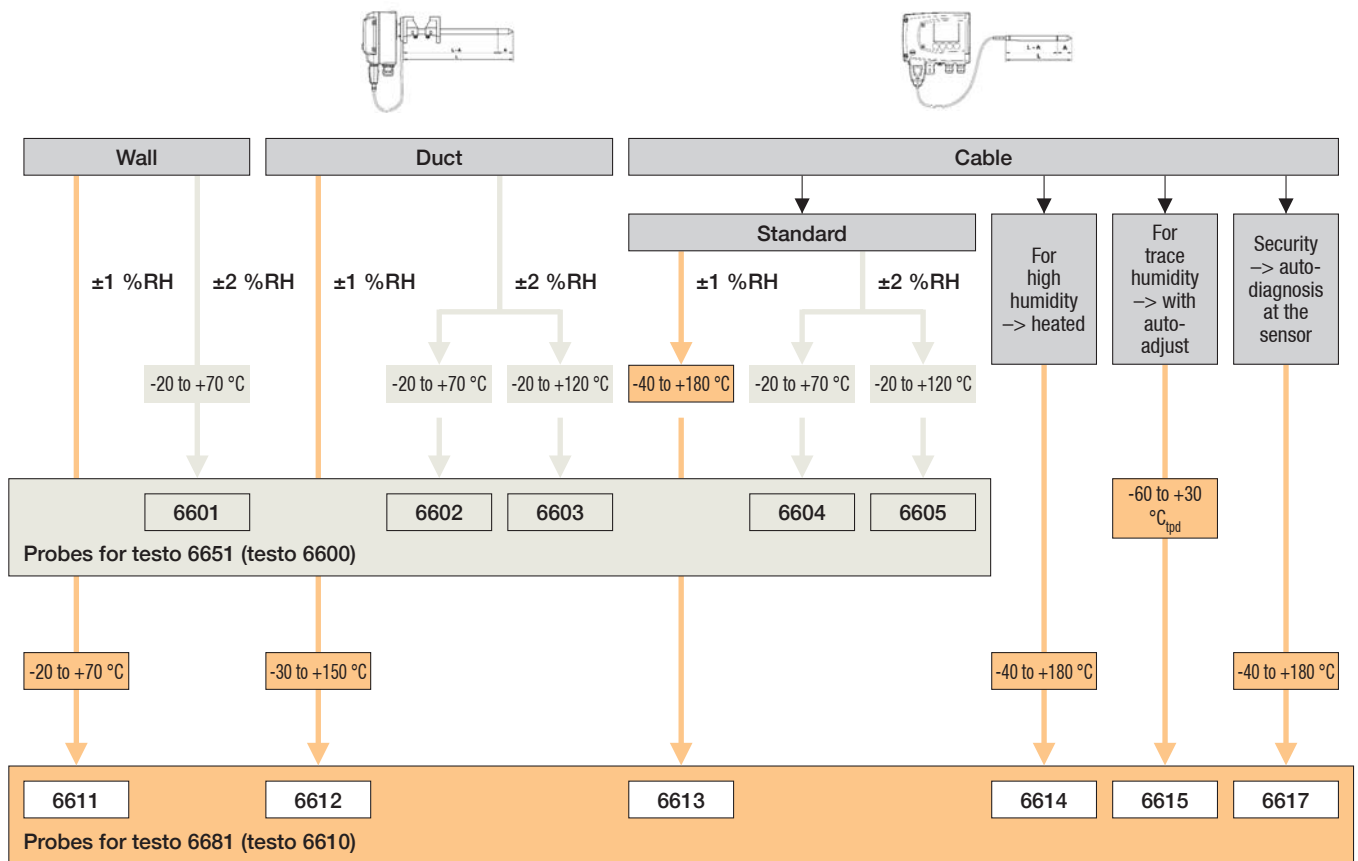

testo 6681 – preventive maintenance through early warning

Early warning system and self-monitoring – preventive maintenance

Today, professional humidity measurement transmitters are usually reliable links in the humidity regulatory chain. Testo has made a significant contribution to this with the help of the robust, condensation-proof Testo humidity sensor. However, if there are corrosive media in the process, this often means that after a while the sensor ceases to function, accompanied by costly rejects (quality deficiency in the end product) and system downtimes.

Testo has developed a special solution for these applications: the Testo “early warning humidity probe” testo 6617. This continuously monitors the Testo humidity sensor for any symptoms of beginning corrosion. It recognizes this situation very early. The person responsible for the system is therefore already warned before measurement errors or measurement interruptions occur.

Not only the probe testo 6617 serves as an early warning. The testo 6681 also has numerous self-analyses, such as

- Warning if a state of condensation exists for too long
- Warning of the suspicion of drift based on the 2-point adjustment
- Warning of unsuitable operating voltage

How are these early warnings passed on to the responsible person? In addition to the clear-text display, one of the four relays can be allocated a “collective alarm”, and customer-specifically with a selection of reports, by the P2A software. Additionally, all individual reports can be transferred, as long as the measurement transmitter has the digital field bus communication Profibus-DP, see below.

Thanks to the early warning, the system supervisor can replace the probe early – and without interrupting the measurement. The experts know: the costs saved by such “preventive maintenance” far exceed the investment.

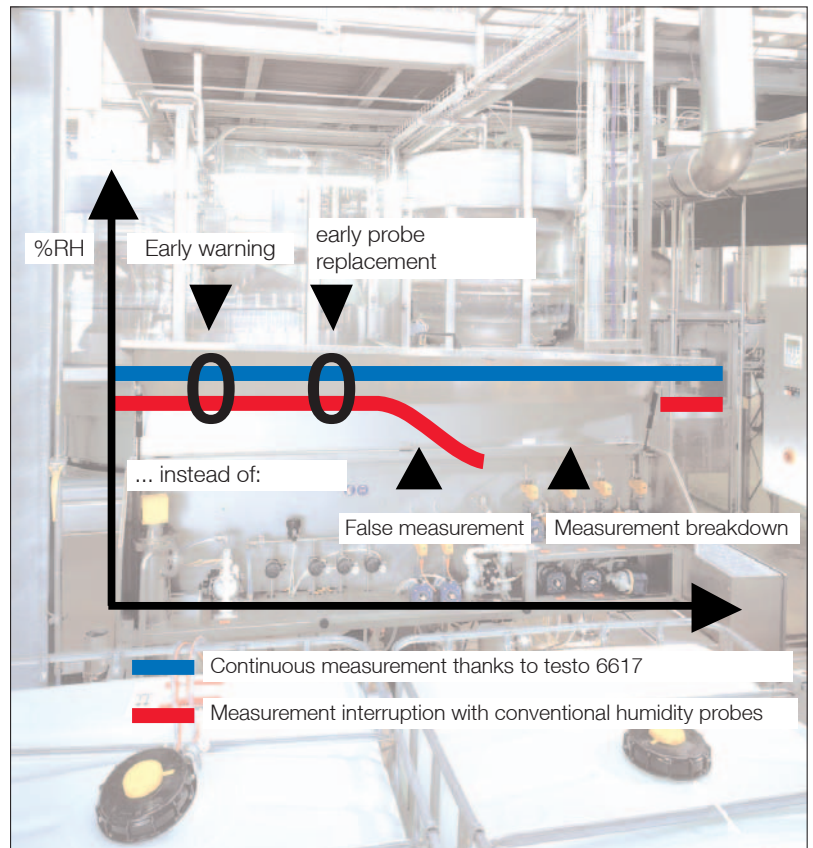

The measurement transmitter testo 6681 with duct probe for industrial application under extreme conditions

testo 6681 – the signal outputs

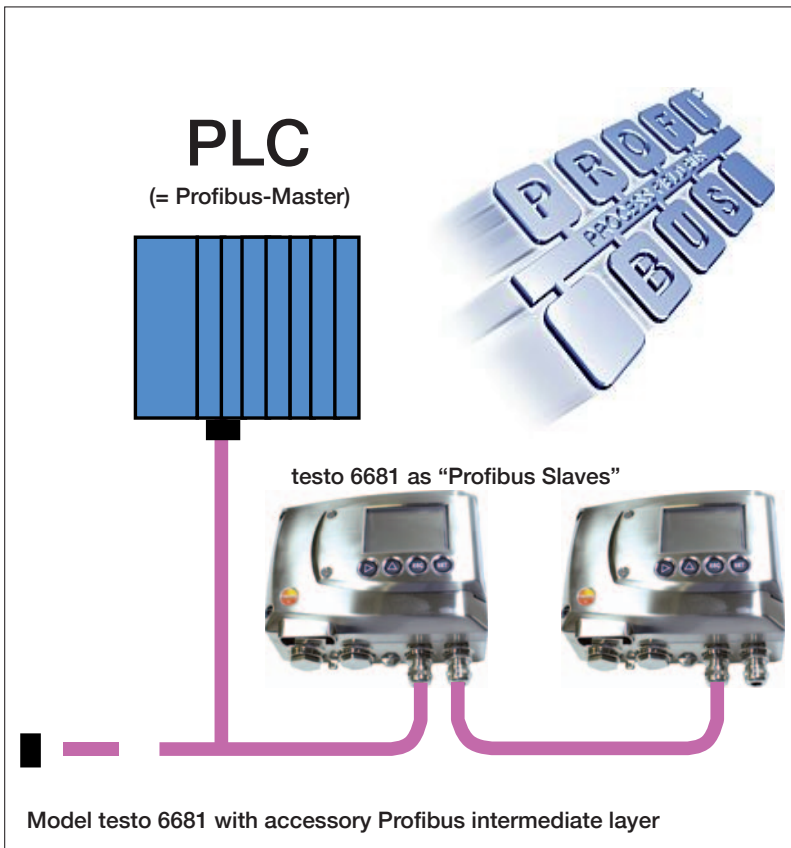

Profibus-DP – finally also for humidity applications

As the first provider of humidity measurement technology in the world, Testo has made the most common field bus available: Profibus-DP. This has become standard in production automation and is also used for drying processes.

Thanks to an "intermediate layer" (sandwich design), the testo 6681 can be equipped with this communication variant ex-works or later on site.

The advantage of the field bus: in addition to the measurement values, all individual reports (i.e. also the numerous self-monitoring reports) can be passed on to the connected control. The relay limit values can also be altered "from above" (see graphic on left), e.g. to suit the current production batch.

Analog outputs – two or optionally three

The testo 6681 is also very versatile regarding its analog outputs. In addition to the type of signal (4 to 20 mA two-wire or four-wire, 0 to 1 V, 0 to 5 V, 0 to 10 V, 0 to 20 mA), the number of analog outputs can be selected when ordering. Two or three channels are available. This means, for example, that the dewpoint can also be continuously monitored, in addition to the relative humidity and the temperature, without the need for complicated calculations in the control.

Integrated relays (optional)

Thanks to the four power relays (up to 256 VAC, 3A), assemblies of the air conditioning system can be directly switched without the "detour" via a control. At the same time, the relays can be used for local alarming or for reporting limit value violations to a superordinate system.

And not least, the person responsible for the system can be called to the measurement site in time with the help of a "collective alarm" (cf. self-monitoring").

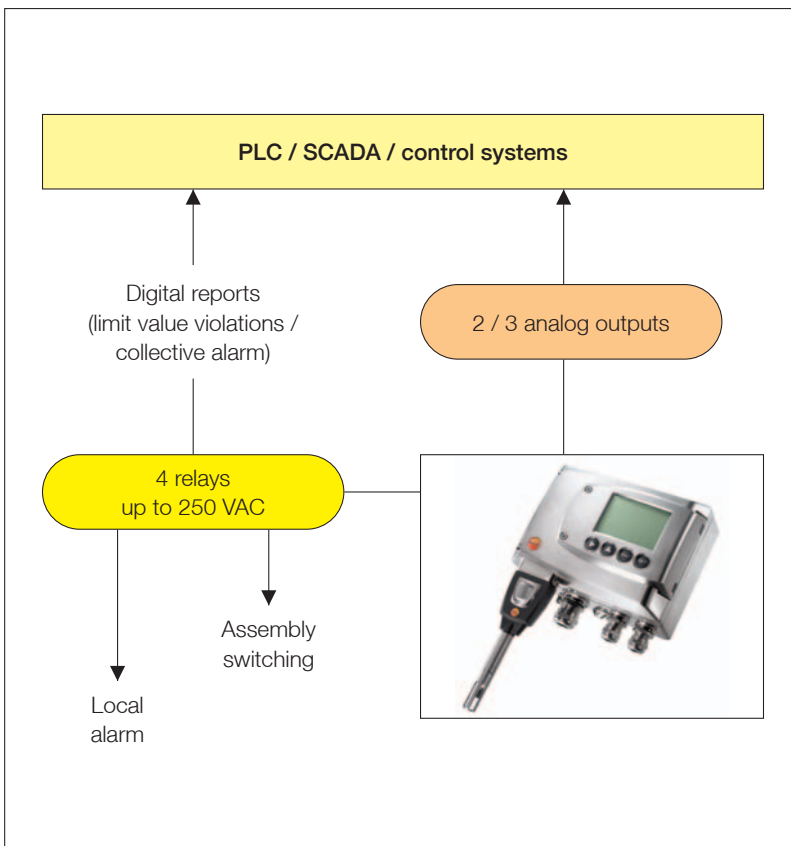

testo 6681 – high humidity and trace humidity

High humidity – testo 6614

Processes with high humidity are among the most demanding challenges in measurement technology. In this range, conventional sensors tend to react slowly, while corrosion – high humidity processes often contain corrosive media – can endanger the long-term useability of the sensor.

Testo provides a unique solution for this application with the digital probe testo 6614. The sensor heating creates a highly stable microclimate, in which fast reaction, highly accurate measurement and corrosion-proofness are guaranteed. With the help of an additional temperature probe, the actual process temperature is measured, and the process humidity calculated in the microprocessor. Long-term stability with high accuracy – up to now, this combination was beyond our reach in the high humidity range.

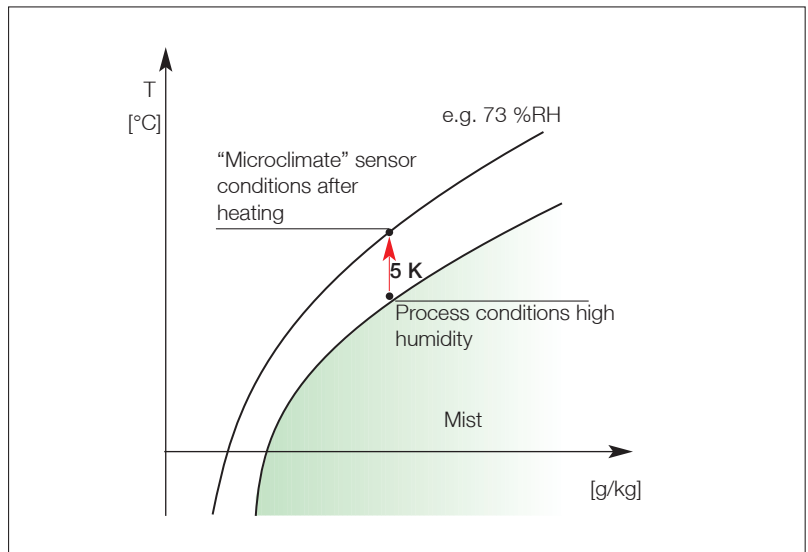

Trace humidity – testo 6615

Trace humidity – i.e. very low relative humidity or dewpoint values – is also a very demanding measurement task. Conventional humidity sensors show their limitations here, especially in their measurement accuracy.

Testo has now succeeded in developing a special sensor on the basis of a self-adjustment. With sensational results: Down to low trace humidities of -60° dewpoint (this corresponds to a relative humidity of 0.03 %RH at $+25^{\circ}\text{C}$), the digital probe testo 6615 still provides highest accuracy.

The appropriate accessories for this application are now also available:

- Prefilter 0554 3311 (for protecting the measurement chamber and sensor)
- Precision measurement chamber 05544 3312 (stainless steel) with adjustable flow-off, for measurements in compressed air up to 35 bar
- Flow-through meter for measurement chamber 0554 3313, for monitoring flow-off from the measurement chamber

With the help of these components, the optimum flow impact of the sensor, at any pressure (up to 35 bar) and with optimum contamination protection, can be set. For long-term stable trace humidity measurements in compressed air and dry gases.

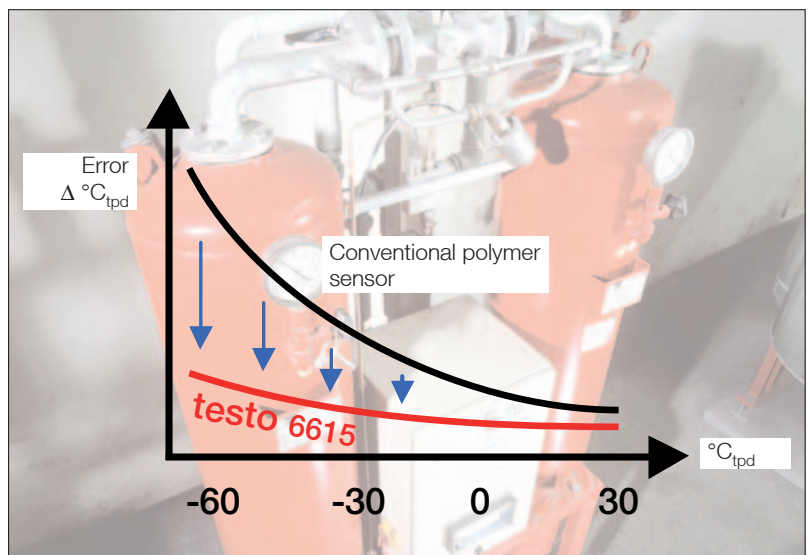

Connection of trace humidity probe testo 6651 via measurement chamber and protective filter

Order code measurement transmitter testo 6681

0555 6681 **A01** Bxx Cxx Dxx Exx Fxx Gxx Hxx Ixx Jxx Kxx

<p>B01 4 to 20 mA (2-wire, 24 VDC), not possible with relays or probes testo 6614/6615</p> <p>B02 0 to 1 V (4-wire, 24 VAC/DC)</p> <p>B03 0 to 5 V (4-wire, 24 VAC/DC)</p> <p>B04 0 to 10 V (4-wire, 24 VAC/DC)</p> <p>B05 0 to 20 mA (4-wire, 24 VAC/DC)</p> <p>B06 4 to 20 mA (4-wire, 24 VAC/DC)</p> <p>B77 Profibus-DP</p>		<p>H00 Without relay</p> <p>H01 4 relay outputs, limit value monitoring</p> <p>H02 4 relay outputs, limit values channel 1 + collective alarm</p>
<p>C00 Without display</p> <p>C02 With display / English</p> <p>C03 With display / German</p> <p>C04 With display / French</p> <p>C05 With display / Spanish</p> <p>C06 With display / Italian</p> <p>C07 With display / Japanese</p>	} Clear-text language	<p>I00 no optional 3rd analog output</p> <p>I01 %RH / min / max</p> <p>I02 °C / min / max</p> <p>I03 °F / min / max</p> <p>I04 °C_{td} / min / max</p> <p>I05 °F_{td} / min / max</p> <p>I06 g/kg / min / max</p> <p>I07 gr/lb / min / max</p> <p>I08 g/m³ / min / max</p> <p>I09 gr/ft³ / min / max</p> <p>I10 ppmV / min / max</p> <p>I11 °C_{wb} / min / max (Wet Bulb)</p> <p>I12 °F_{wb} / min / max (Wet Bulb)</p> <p>I13 kJ/kg / min / max (enthalpy)</p> <p>I14 hPa / min / max (water vapour partial pressure)</p> <p>I15 inch H₂O / min / max (water vapour partial pressure)</p> <p>I16 °C_{tm} / mixture dewpoint for H₂O₂</p> <p>I17 °F_{tm} / mixture dewpoint for H₂O₂</p>
<p>D01 Cable input M16 (relay: M20)</p> <p>D02 Cable input NPT 1/2"</p> <p>D03 Cable contact via via M plug connection</p>		
<p>F01 %RH / min / max</p> <p>F02 °C / min / max</p> <p>F03 °F / min / max</p> <p>F04 °C_{td} / min / max</p> <p>F05 °F_{td} / min / max</p> <p>F06 g/kg / min / max</p> <p>F07 gr/lb / min / max</p> <p>F08 g/m³ / min / max</p> <p>F09 gr/ft³ / min / max</p> <p>F10 ppmV / min / max</p> <p>F11 °C_{wb} / min / max (Wet Bulb)</p> <p>F12 °F_{wb} / min / max (Wet Bulb)</p> <p>F13 kJ/kg / min / max (enthalpy)</p> <p>F14 mbar / min / max (water vapour partial pressure)</p> <p>F15 inch H₂O / min / max (water vapour partial pressure)</p>	} Channel 1* =	<p>K01 IM German-English</p> <p>K02 IM French-English</p> <p>K03 IM Spanish-English</p> <p>K04 IM Italian-English</p> <p>K05 IM Dutch-English</p> <p>K06 IM Japanese-English</p> <p>K07 IM Chinese-English</p>
<p>G01 %RH / min / max</p> <p>G02 °C / min / max</p> <p>G03 °F / min / max</p> <p>G04 °C_{td} / min / max</p> <p>G05 °F_{td} / min / max</p> <p>G06 g/kg / min / max</p> <p>G07 gr/lb / min / max</p> <p>G08 g/m³ / min / max</p> <p>G09 gr/ft³ / min / max</p> <p>G10 ppmV / min / max</p> <p>G11 °C_{wb} / min / max (Wet Bulb)</p> <p>G12 °F_{wb} / min / max (Wet Bulb)</p> <p>G13 kJ/kg / min / max (enthalpy)</p> <p>G14 mbar / min / max (water vapour partial pressure)</p> <p>G15 inch H₂O / min / max (water vapour partial pressure)</p>	} Channel 2* =	

Order example measurement transmitter testo 6681

Housing with display with menu in English

4 to 20 mA (4-wire)

Cable input M16/M20

Factory setting channel 1:

°C_{tpd} with scaling min 0 °C_{td}, max 100 °C_{td}*

Factory setting channel 2:

°C with scaling min -10 °C, max 70 °C*

with relay

without 3rd channel

Instruction manual in Spanish + English

→ **0555 6681 A01 / B06 / C02 / D01 / F04 / 0 / 100 / G02 / -10 / +70 / H01 / I00 / K03**

* The standard scaling is delivered without "min" and "max"

Ordering options probe range testo 6610

0555 6610 **Lxx** **Mxx** **Nxx** **Pxx**

L11	Probe 6611
L12	Probe 6612
L13	Probe 6613
L14	Probe 6614
L15	Probe 6615
L17	Probe 6617

M01	Sintered stainless steel filter
M02	Wire mesh protective cap
M03	Sintered Teflon filter
M04	Metal protective cap, open
M05	Plastic protective cap ABS, open
M06	Teflon filter with drip hole
M07	Teflon filter with drip hole and condensation protection
M08	Filter for H ₂ O ₂ environments

} specially for high humidity

Order example probe 6613

Cable probe, -40 to +180 °C
Sintered stainless steel filter
Cable length 2 m
Probe length 300 mm

→ **0555 6610 L13 / M01 / N02 / P30**

	L11	L12	L13	L14	L15	L17
N00	Without cable (for probe 6601)	X	-	-	-	-
N01	Cable length 1 m (for probes 6604/6605)	-	-	X	X	X
N02	Cable length 2 m (for probes 6604/6605)	-	-	X	X	X
N05	Cable length 5 m (for probes 6605 only)	-	-	X	X	X
N10	Cable length 10 m	-	-	X	X	X
N23	Cable length, specially for duct versions (for probe 6612)	-	X	-	-	-

	L11	L12	L13	L14	L15	L17
P07	Probe length 70 mm	X	-	-	-	-
P14	Probe length 140 mm	-	-	X	-	-
P20	Probe length 200 mm	X	X	X	X	X
P30	Probe length 300 mm	-	X	X	-	-
P50	Probe length 500 mm	-	X	X	X	X
P80	Probe length 800 mm	-	X	X	-	-

Ordering procedure:

The measurement transmitter and the probes can be ordered independently of each other, (thanks to the digital probe interface), cf order examples above.

If the measurement transmitter and the probe order are to be assembled together, their order codes are combined in the distribution set 0563 6681



Technical data measurement transmitter testo 6681

GENERAL								
Housing	Metal							
Dimensions	122 x 162 x 77 mm (without probe)							
Weight	1.5 kg (without probe)							
Display	2-line LCD with clear-text line (optional) and relay status display							
Resolution display	0.1 %RH / 0.1 °C							
Cable screw fitting (Code D01)	M 16 x 1.5 (2x) with inner diameter 4-8 mm M 20 x 1.5 (2x) with inner diameter 6-12 mm							
Probe connection	Digital plug-in connection							
Voltage supply	2-wire: 24 VDC ±10 % 4-wire: 20 to 30 VAC/DC, 200 mA max. current consumption							
Protection class	IP 65							
EMC	2004/108/EG							
Operating temperature housing	-40 to +70 °C, with display 0 to +50 °C							
Storage temperature	-40 to +80 °C							
Measurement parameters	Dependent on probe, altogether are available: Temperature in °C / °F; relative humidity %rF (%RH); dewpoint in °C _{td} (°F _{td}); pressure dewpoint in °C _{tpd} (°F _{tpd}); absolute humidity in g/m ³ (gr/ft ³); degree of humidity in g/kg (gr/lb); enthalpy in kJ/kg (BTU/lb); psychrometer temperature in °C _{tw} (°F _{tw}); water vapour partial pressure in hPa / H ₂ O; water content in ppm vol / % Vol; mixture dewpoint H ₂ O ₂ / in °C _{tm} / °F _{tm}							
Measurement medium	Air, nitrogen, more on request: applicationsupport@testo.de							
SENSOR (more data see probes)								
Humidity	Testo humid. sensor, cap.							
Reproduceability	better than ±0.5 %RH							
Measurement inaccuracy %RH	cf. probe data							
Probes	6611	6612	6613	6614	6615	6617		
Measuring range	Humidity	0 to 100 %RH				-60 to +30 °C _{tpd}	0 to 100 %RH	
	Temperature	-20 to +70 °C	-30 to +150 °C	-40 to +180 °C	-40 to +180 °C	-40 to +180 °C	-40 to +180 °C	
Measuring range (Standard scaling)	%RH	°C _{td}	°F _{td}	g/m ³	g/kg	°C _{wb}	°F _{wb}	
	0 to 100	-80 to +100	-112 to +212	0 to 600	0 to 9500	-40 to +180	-40 to +356	
Reaction time without protective filter	t 90 max. 10 s							
ANALOG OUTPUT (uniform for all channels, specify when ordering)								
Quantity	2 channels (type analog signal uniform for both channels, specify when ordering) additional 3rd channel (optional)							
Current/accuracy	4 to 20 mA ±0.03 mA (2-wire) 0 to 20 mA ±0.03 mA (4-wire) 4 to 20 mA ±0.03 mA (4-wire) for heated sensor technology							
Voltage/accuracy	0 to 1 V ±1.5 mV (4-wire) 0 to 5 V ±7.5 mV (4-wire) 0 to 10 V ±15 mV (4-wire)							
Galvanic isolation	Galvanic isolation of the output channels (2-wire and 4-wire), isolation of supply from outputs (4-wire)							
Resolution	12 bit							
Maximum load	2-wire	12 VDC: 100 Ohm 24 VDC: 500 Ohm 30 VDC: 625 Ohm						
	4-wire	500 Ohm						
FURTHER OUTPUTS								
Relays	4 relays (free allocation to measurement channels or as collective alarm), up to 256 VAC / 3 A, NC/C/NO (optional)							
Digital output	Mini DIN for Testo P2A parameterization software and Testo portable instruments 400/650 (optional) Profibus-DP (optional as an intermediate layer)							

Technical data probe range testo 6610

Model	testo 6611	testo 6612	testo 6613	testo 6614	testo 6615	testo 6617
Type	Wall	Duct	Cable	Heated cable	Cable trace humidity (self-adjustment)	Cable with cover electrode monitoring
Application	Room climate probe wall mounting	Process humidity probe duct mounting	Process humidity probe flexible with cable	Humidity probe for high humidity applications / when risk of condensation	Humidity probe for trace humidity / pressure dewpoint (with self-adjustment)	Humidity probe with self-monitoring for sensor-damaging media
Measurement parameters	°C/°F, %F/%RH, °C _{td} /°F _{tpd} , °C _{tpd} /°F _{tpd} , g/m ³ /gr/ft ³ , g/kg/gr/lb, kJ/kg, BTU/lb, °Ctw/°Ftw, hPa, inch H ₂ O, ppm vol %, %vol, °Ctm (H ₂ O ₂)/°Ftm (H ₂ O ₂)					
Measuring range	Humidity	0 to 100 %RH			-60 to +30 °C _{tpd}	0 to 100 %RH
	Temperature	-20 to +70 °C	-30 to +150 °C	-40 to +180 °C		
Material	Probe shaft	Stainless steel				
	Cable	FEP coated				
	Plug	Plastic ABS				
Measurement inaccuracy*	Humidity: (+25 °C)	±(1 %RH + 0,007 x mv) for testo 6611/12/13/14 ±(1,2 %RH + 0,007 x mv) for testo 6617				
	Humidity: for deviations from ±25 °C	±0.02 %RH/K				
	Pressure dewpoint				±1 K at 0° C _{tpd} ±2 K at -40° C _{tpd} ±4 K at -50° C _{tpd}	
	Temperature: at +25 °C / +77 °F	±0.2 °C / 0.38 °F				
Reproduceability	Humidity	better than ±0.5 %RH				
Probe dimensions	Diameter	12 mm				
	Probe shaft length L	80/200 mm	200/300/500/800 mm	120/200/300/500/800 mm	200/500 mm	
Cable length		-	specifically for duct versions	1/2/5/10 m		
Pressure tightness		PN 1 (probe tip)		PN 10 (probe tip) PN 3 (probe end)	PN 16 (probe tip)	PN 1 (probe tip)

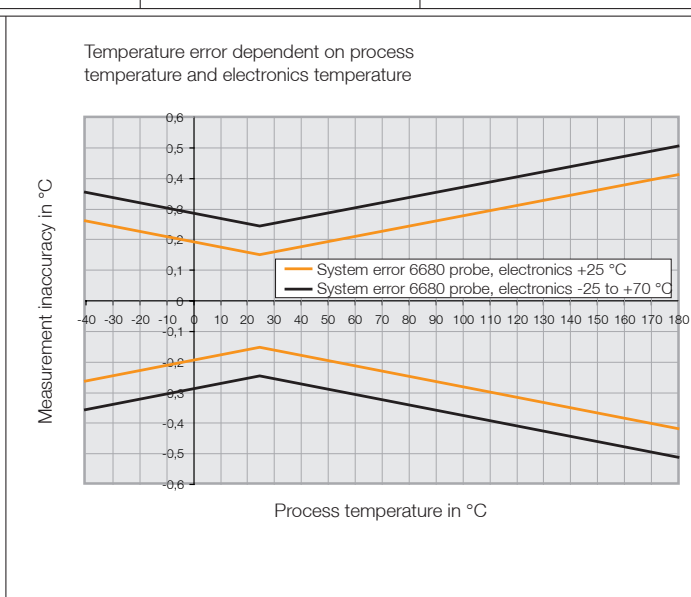
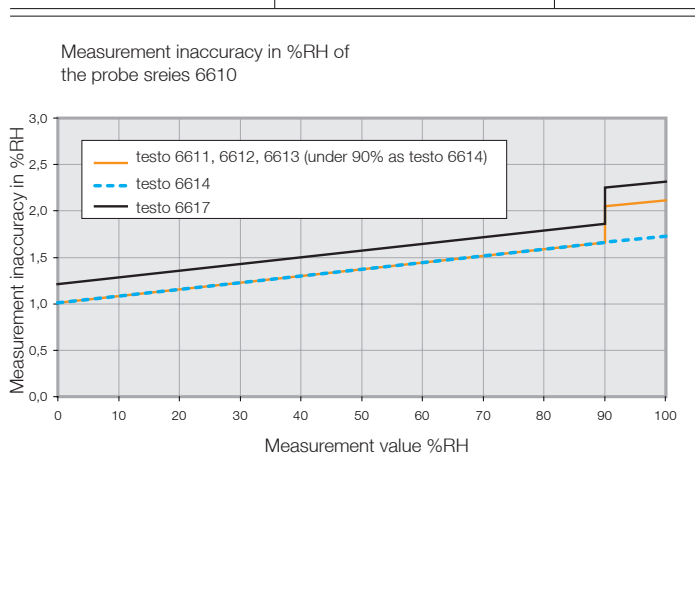
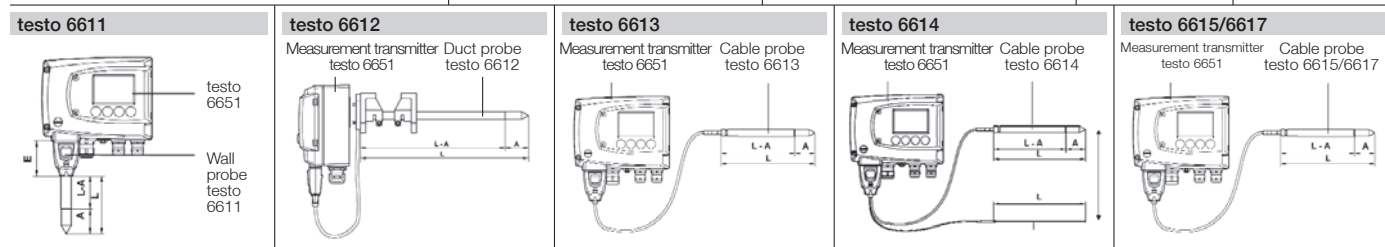

*Other accuracies apply for the wall probe with 70 mm length in combination with a current output (P07):
Operation: with 2 channels at 12 mA, without display illumination, relay off, additional measurement inaccuracy to above data at +25 °C (+77 °F), humidity ±2.5 %RH, temperature ±1 °C (1.8 °F)

Common accessories testo 6651 and testo 6681

Interface and software	Part no.	
P2A software (parameterisation, adjustment and analysis software for PC), with USB cable (for PC) to mini DIN (instrument)	0554 6020	

Fixings, mounting assistance	Part no.	
Wall/duct holder (for mounting duct version in duct or for mounting duct version on wall)	0554 6651	
Basic single hole duct screw fitting in plastic (polyamide, -20...+80 °C), gasket ring in NBR	0554 1793	
Duct screw connection (aluminium/PVC)	0554 1794	
Pressure-tight screw connection G1/2" (st. steel) with cutting ring to 10 bar	0554 1795	
Pressure-tight screw connection G1/2" (st. steel) with Teflon ring to 6 bar	0554 1796	
Stainless steel flange for screw connections to DIN 2576	0554 1797	

Plug connections	Part no.	
Plug connection M12 5-pin plug and socket	0554 6682	
Profibus plug and socket	0554 6683	
Profibus end resistance	0554 6688	

Sensor filters and protective caps	Part no.	
Stainless steel sintered cap, Ø 12 mm, is screwed onto humidity probe for measurements at high flow velocities or in contaminated air	0554 0647	
Cap with wire mesh filter, Ø 12 mm	0554 0757	
Teflon sintered filter, Ø 12 mm, for corrosive substances high humidity range (long-term measurements), high velocities	0554 0756	
Metal protection cage, Ø 12 mm for humidity probes for measurement in flow velocities of less than 10 m/s	0554 0755	
Plastic protective cap (open), fast reaction time at flow velocities <7 m/s (not suitable for dusty atmospheres)	0192 0265	
Protection cap made of Teflon With 1.5 mm condensate drip hole	0554 9913	
Protection from moisture (aluminium) Protects sensor from condensation e.g. in drying systems	0554 0166	

Accessories for pressure dewpoint measurement (only testo 6681 with probe testo 6615)	Part no.	
Prefilter, protects measurement chamber and sensor from dirt particles	0554 3311	
Precision measurement chamber with adjustable flow-off	0554 3312	
Flow-through meter for measurement chamber to adjust specific flow-off of sensor	0554 3313	

Adjustment possibilities	Part no.	
Adjustment adapter (for 1-point adjustment with testo 400 or testo 650)	0554 6022	
testo saline pots for control and humidity adjustment of humidity probes, 11.3 %RH and 75.3 %RH with adapter for humidity probe	0554 0660	
Reference set (testo 650, 1 %RH probe with certificate)	0699 3556/15	

Supply	Part no.	
Mains unit (desk-top) 110 to 240 VAC/24 VDC (350mA)	0554 1748	
Mains unit (rail mounting) 90 to 264 VAC/ 24 VDC (2.5A)	0554 1749	

Calibration	Part no.	
ISO calibration certificate/electrical (for measurement transmitter analog outputs) calibration in measurement ranges 0 to 20 mA; 4 to 20 mA; 0 to 1 V; 0 to 10 V	0520 1000	
Standard DKD calibration, measurement transmitter only	0520 1200	
ISO calibration certificate humidity	0520 0176	
ISO calibration certificate/humidity data loggers; calibration points freely selectable from 5 to 95%RH at +15 to +35°C or -18 to +80°C	0520 0066	
DKD calibration certificate humidity	0520 0276	
DKD calibration certificate/humidity cal. points freely selectable from 5 to 95%RH at +25° C or +5 to +70°C	0520 0236	

- 50 YEARS OF TESTO
- More innovative than ever
- 50 innovations in the anniversary year



INNOVATION 2007