

testo 6383 Ethernet · differential pressure transmitter

testo 6610 · Probes

P2A software · Parameterizing, adjusting and analyzing software

Instruction manual Volume 2

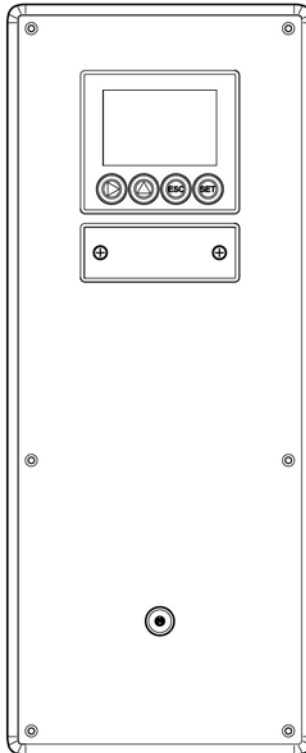



5 Contents

5	Contents	79
6	testo 6610 probes	81
6.1.	Specifications	81
6.1.1.	Functions and use	81
6.1.1.1.	Digital probes:.....	81
6.1.1.2.	The Testo humidity sensor.....	81
6.1.1.3.	Self-diagnosis	82
6.1.2.	Design of the probe.....	83
6.1.3.	Accessories	83
6.2.	Product description.....	84
6.2.1.	Overview of probe and filter types.....	84
6.2.1.1.	Probe version.....	84
6.2.1.2.	Determining the accuracy/measuring uncertainty.....	84
6.2.1.3.	Ordering options for testo 6610 probe (0555 6610).....	85
6.2.1.4.	Protection caps	86
6.2.2.	Integrated humidity probe	87
6.2.3.	testo 6613 cable probe	90
6.2.4.	testo 6614 heated cable probe.....	94
6.2.5.	testo 6617 cable probe (self-monitoring).....	102
6.2.5.1.	Self-monitoring of cover electrode.....	103
6.3.	Commissioning.....	106
6.3.1.	Installing the probe	106
6.3.1.1.	Installing testo 6613/6614/6615/6617 probes.....	106
6.3.2.	Connecting/removing the probe to/from the transmitter.....	110
6.4.	Maintenance and cleaning.....	110
6.4.1.	Replacing filters/protection caps	110
6.4.1.1.	Replacing the filter/protection caps for wall version.....	110
6.4.1.2.	Replacing the filter/protection cap for duct versions	111
6.4.2.	Cleaning the instrument and filter/protection cap	112
6.4.3.	Replacing the sensor	112
7	Parameterizing, adjusting and analyzing software (P2A software).....	113
7.1.	Specifications	113
7.1.1.	Functions and use	113
7.1.2.	System requirements.....	114
7.1.3.	Scope of delivery	114
7.2.	First steps.....	115
7.2.1.	Installing the software/driver	115
7.2.1.1.	Installing P2A software.....	115
7.2.1.2.	Installing USB driver	115
7.2.1.3.	P2A software upgrade	115

7.2.2.	Starting the software.....	115
7.2.2.1.	Starting the program.....	115
7.2.2.2.	Establishing a connection with the instrument.....	115
7.2.2.3.	Activating the connection with the instrument.....	116
7.3.	Using the software.....	116
7.3.1.	User interface.....	116
7.3.2.	Editing instrument/parameter file.....	119
7.3.2.1.	Changing instrument/parameter file.....	119
7.3.2.2.	Saving parameters.....	129
7.3.2.3.	Opening the parameter file.....	129
7.3.2.4.	Copying and pasting parameters.....	129
7.3.2.5.	Deleting instrument/parameter file.....	130
7.3.2.6.	Creating a new instrument file.....	130
7.3.3.	Analyzing/testing the transmitter.....	130
7.3.3.1.	Analyzing/testing the instrument.....	130
7.3.3.2.	Carrying out factory reset.....	131
7.3.3.3.	Testing analog output.....	131
7.3.3.4.	Testing switch output relays 1 to 4.....	133
7.3.3.5.	Displaying min./max. values.....	134
7.3.4.	Adjusting the transmitter.....	135
7.3.4.1.	1-point adjustment.....	135
7.3.4.2.	n-point adjustment.....	137
7.3.4.3.	Adjusting the analog output.....	138
7.3.5.	Transmitter history.....	139
8	Tips and assistance.....	144
8.1.	Questions and answers.....	144
8.2.	Accessories and spare parts.....	144
8.2.1.	Ordering options for testo 6383 transmitter (0555 6383).....	146
8.2.2.	Ordering options for testo 6610 probes (0555 6610).....	150

6 testo 6610 probes

6.1. Specifications

6.1.1. Functions and use

The plug-in, adjusted probes from the testo 6610 family are used together with the testo 6383 transmitter.

These measuring units are suitable for the following applications, for example:

- Process instrumentation
- Clean rooms
- Test benches
- Drying processes
- Production and storage air quality
- Complex room climate applications.

6.1.1.1. Digital probes:

The probes are adjusted in the factory and transmit their adjustment data to the internal memory of the testo 6383 transmitter. The information is only transmitted between the probes and transmitter digitally. The probes can therefore be disconnected from the transmitter for adjustment or servicing while the transmitter itself can remain at the measuring point.



Hint: We recommend in this case that a probe of the same type be inserted into the transmitter immediately in order to be able to continue measuring with minimal interruption.

The transmitter identifies the probe and records that a probe was connected in the history.



The testo 6383 transmitter can only be used with testo 6610 probes.

6.1.1.2. The Testo humidity sensor

With the Testo humidity sensor, which has been in successful use and continually improved for more than ten years, the focus has from the very beginning been on both accuracy parameters, namely measuring uncertainty and long-term stability.

The capacitive humidity sensor is in principle a plate capacitor consisting of two electrically conductive plates (electrodes **(1)** and **(2)**, see diagram below) opposite each other.

A humidity-sensitive polymer **(5)** serves as the dielectric. The special feature lies in the perfect way the individual layers are matched to each other. This is evident particularly in the top electrode, which has to perform two tasks that, at first glance, appear contradictory: it must be completely permeable to the water vapour that is to be fed into the polymer dielectric, but at the same time it must be impervious, smooth and repellent to condensate, oil and dirt in order to protect the sensor.

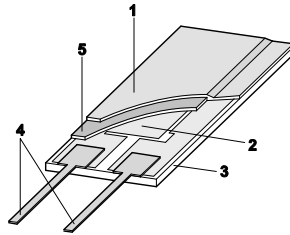

- 1 Cover electrode
- 2 Bottom electrode
- 3 Substrate (ceramic substrate for mechanical protection)
- 4 Connections (protected against corrosion)
- 5 Dielectric layer



The humidity sensor cannot be exchanged by the customer (except for 6611). The humidity sensor may not be damaged or touched. Contamination and damage lead to an impairment of the measurement and the measuring accuracy.

6.1.1.3. Self-diagnosis

The probes in the testo 6610 range monitor their functionality themselves and report the following faults:

- Sensor breaks
- Sensor short-circuit
- Condensation

The condensation message is issued at a reading of 100 % RH and deactivated once the readings are within the valid range.

- Error message with drift at the adjustment points
- Value for relative humidity less than 0 % RH.

The trigger threshold is set at -2 % RH. This means that an error message is only issued once a clear effect is discernible.

- Early warning when sensor corrosion is starting to develop

The testo 6617 probe is able to signal the first signs of corrosion. The probe can thus be changed at an early stage without interrupting the machine availability.

- Self-adjustment (testo 6615 only)
- Excess temperature
Error message if permissible process temperature is exceeded

6.1.2. Design of the probe

The probes of the testo 6610 family are made up of the following components (included in delivery):

- Probe connector
- Probe shaft with protection cap and sensors (% RH and °C or °F)
- Probe cable bend radius minimum \varnothing 50 mm.

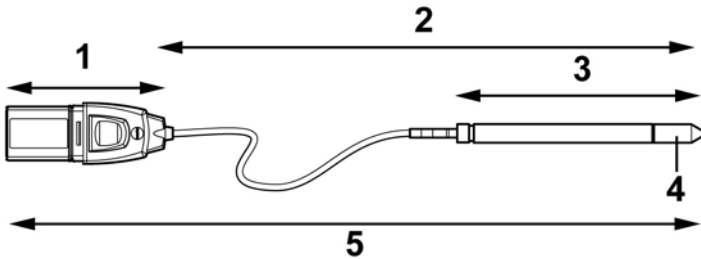

- 1 Probe connector
- 2 Probe length
- 3 Probe
- 4 Protection cap, sensor underneath
- 5 Probe

6.1.3. Accessories

The following accessories are available for the probes from the testo 6610 family:

- Filters and protection caps (see Protection caps, page 86)
- Calibration certificate in accordance with ISO and DKD (see Accessories and spare parts, page 144).

6.2. Product description

6.2.1. Overview of probe and filter types

6.2.1.1. Probe version

A detailed description of the probe versions can be found from Integrated humidity probe, page 87 onwards.

The following probe versions are available for the testo 6383 transmitter:

Version	Article no.	Characteristic
Integrated humidity probe	KMAT option D04 (0636 6610)	Wall probe version; accuracy to ± 1 % RH; temperature range -20 to +70 °C/-4 to +158 °F, plug-on sensor
testo 6612	0555 6610-L12	Duct probe version; accuracy to ± 1 % RH; temperature range -30 to +150 °C/-22 to +302 °F, sensor soldered
testo 6613	0555 6610-L13	Cable probe version; accuracy to ± 1 % RH; temperature range -40 to +180 °C/-40 to 356 °F, sensor soldered
testo 6614	0555 6610-L14	Heated cable probe version; accuracy to ± 1 % RH; temperature range -40 to +180 °C/-40 to 356 °F, sensor soldered
testo 6615	0555 6610-L15	Trace humidity cable probe version; accuracy to ± 6 K at -60 °Ctd; temperature range -40 to +120 °C/-40 to +248 °F, sensor soldered
testo 6617	0555 6610-L17	Cable with cover electrode monitoring probe version; accuracy to ± 1.2 % RH; temperature range -40 to +180 °C/-40 to +356 °F, sensor soldered

6.2.1.2. Determining the accuracy/measuring uncertainty

The entries for the measuring uncertainty for the probe are determined in accordance with GUM (Guide to the Expression of Uncertainty in Measurement/DIN V ENV 13005).

All parts that make up the measuring uncertainty given by Testo are listed below. When comparing the measuring uncertainty/accuracy between manufacturers, which components are included is to be taken into account. In many cases, not all elements that contribute to measuring uncertainty are assessed, for

example if the error contribution of the production adjustment for some manufacturers is shown separately or not at all.

The measuring uncertainty of the probe includes the sensor and its electronics as well as the output of the digital measuring signal:

- 1 Linearity including scatter Systematic error and scattering of the components (due to manufacturing tolerances)
- 2 Hysteresis Hysteresis indicates the maximum deviation of the readings that are obtained when you set the same value for the parameter, once coming from a smaller value, once coming from a larger value (humidity sensors actually have no hysteresis, but rather very slow adjustment effects that appear to be hysteresis when considered only for a short period.)
- 3 Reproducibility Repeatability (scattering of the readings in the event of the same parameter being entered successively)
- 4 Production adjustment area The measuring uncertainty of the reference instruments of the adjustment area (including the reference instrument) in production
- 5 Uncertainty of the testing Uncertainty of the procedure for determining points 1 and 2

6.2.1.3. Ordering options for testo 6610 probe (0555 6610)

Order code	Characteristic
Lxx Probe type	
L12	Probe 6612
L13	Probe 6613
L14	Probe 6614
L15	Probe 6615
L17	Probe 6617
Mxx Protection caps	
M01	Protection cap made of stainless steel
M02	Protection cap made of wire mesh
M03	Protection cap made of PTFE

Order code	Characteristic
M04	Metal protection cap (open)
M06	PTFE protection cap with condensate drip hole
M07	Protection cap made of PTFE with condensate drip hole and condensation protector
M08	Protection cap for H ₂ O ₂ atmospheres
Nxx Cable length	
N01	1 m cable length (testo 6613, 6614, 6615, 6617)
N02	2 m cable length (testo 6613, 6614, 6615, 6617)
N05	5 m cable length (testo 6613, 6614, 6615, 6617)
N10	10 m cable length (testo 6613, 6614, 6615, 6617)
N23	Cable length specifically for duct versions (testo 6612)
Pxx Probe length	
P12	Probe length approx. 120 mm (testo 6613)
P20	Probe length approx. 200 mm (testo 6612, 6613, 6614, 6615, 6617)
P30	Probe length approx. 300 mm (testo 6612, 6613)
P50	Probe length approx. 500 mm (testo 6612, 6613, 6614, 6615, 6617)
P80	Probe length approx. 800 mm (testo 6612, 6613)

6.2.1.4. Protection caps

One of the following protection caps can be used for each probe version:

Filter*	Article no. **	Characteristic	Length A (mm)
M01	0554 0647	Protection cap made of stainless steel	33
M02	0554 0757	Protection cap made of wire mesh	40.3
M03	0554 0759	Protection cap made of PTFE	35

Filter*	Article no. **	Characteristic	Length A (mm)
M04	0554 0755	Metal protection cap (open)	35
M06	0554 9913	PTFE protection cap with condensate drip hole	35
M07	0554 9913 + 0554 0166	Protection cap made of PTFE with condensate drip hole and condensation protector	35 55
M08	0699 5867/1	Protection cap for H ₂ O ₂ atmospheres	35

* When ordering the probe, please use this protection cap code, cf. Ordering options for testo 6610 probes (0555 6610), page 150.

** When purchasing a replacement (protection cap only), please use this order number.

6.2.2. Integrated humidity probe

The integrated humidity probe is mounted on the wall together with the ready-wired testo 6383 transmitter.

At a glance

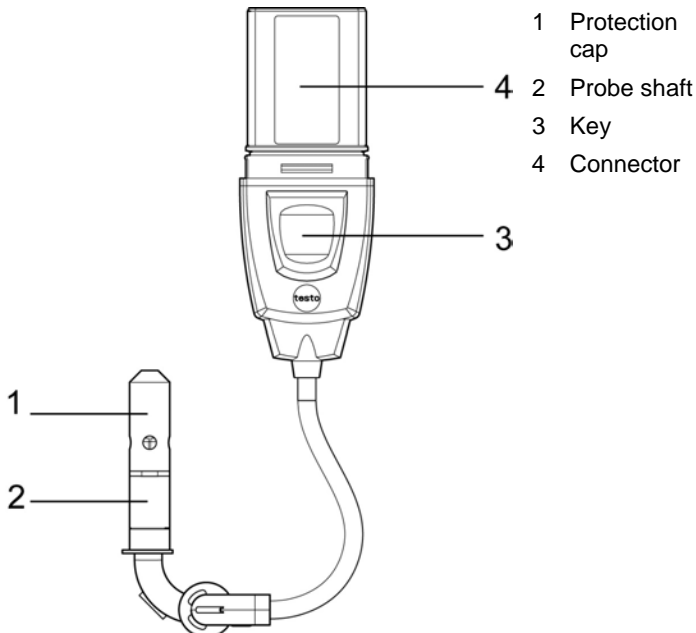

Application

- Monitoring and regulating the air quality in clean rooms

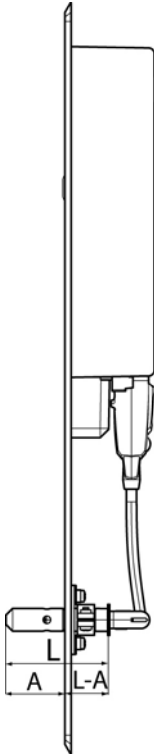

Technical data

Parameters

- Humidity (% RH/°C_{td}/°F_{td}) etc.
- Temperature

Measuring range

- Humidity: 0 to 100 % RH
- Temperature: -20 to +70 °C/-4 to +158 °F

Material

- Probe shaft: Stainless steel
- Connector: ABS plastic

Accuracy (at 25 °C/77 °F)*

- Humidity
 - $\pm (1.0 \% \text{ RH} + 0.007 \times \text{reading})$ for 0 to 90 % RH
 - $\pm (1.4 \% \text{ RH} + 0.007 \times \text{reading})$ for 90 to 100 % RH
 - 0.02 % RH/K, dependent upon the process temperature (with a deviation of 25 °C/+77 °F)
 - 0.02 % RH/K, dependent upon the electronics temperature (with a deviation of 25 °C/+77 °F)
 - Temperature
 - $\pm 0.15 \text{ °C}$ (0.27 °F) with slope PT1000 DIN 1/3 class B
- * Refer to the charts below for the correlation between temperature and accuracy.

Reproducibility

- Better than $\pm 0.2 \% \text{ RH}$

Sensor

Response time without protective filter: t 90 max. 15 s

Probe dimensions

- Diameter of probe shaft: 12 mm
- L = approx. 47 mm
- L – A = 32 mm
- A, see Table Protection caps, page 86

Measuring accuracy of the integrated humidity probe

Humidity error, absolute $|\pm \% \text{ RH}|$ as a factor of process humidity (% RH)

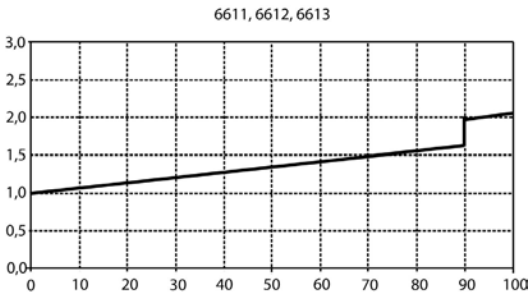

Temperature error as a factor of process temperature and temperature of electronics

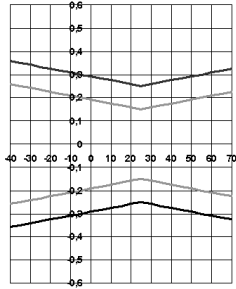

Grey line: System error 6383 + probe, electronics 25 °C/+77 °F

Black line: System error 6383 + probe, electronics -25 to 70 °C/-13 to 158 °F

6.2.3. testo 6613 cable probe

The testo 6613 probe is used when the spatial separation of the transmitter and probe is required.

At a glance

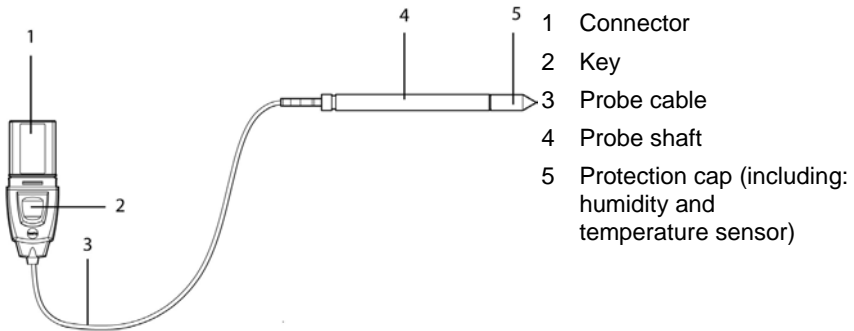

- 1 Connector
- 2 Key
- 3 Probe cable
- 4 Probe shaft
- 5 Protection cap (including: humidity and temperature sensor)

⚠ WARNING

In the event of overpressures, the probe may become a projectile.

> Mount the probe pressure-tight (see pressure resistance under Technical data)

Application

- Monitoring and regulating industrial humidity processes (apart from high-humidity processes), e.g. food production, storing fruit
- Monitoring the production and storage air quality when manufacturing and storing hygroscopic products
- Meeting the top accuracy requirements
- Clean room applications
- Applications for which a sturdy metal housing is required.



Testo recommends that the testo 6614 (heated) probe be used for continuous high-humidity processes.

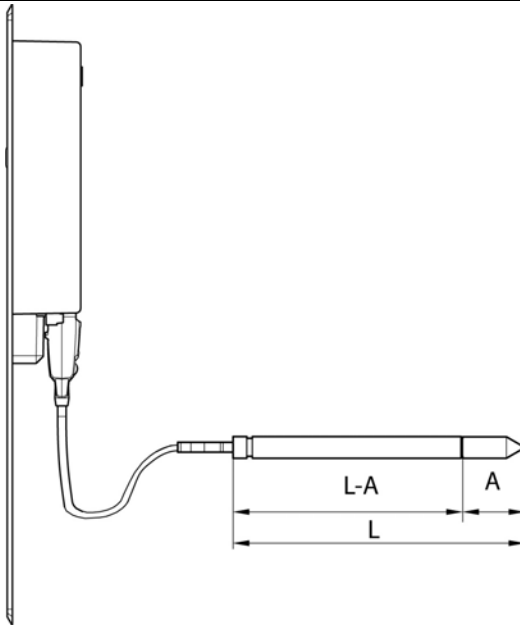

Technical data

Parameters

- Humidity
- Temperature

Measuring range

- Humidity: 0 to 100 % RH
- Temperature: -40 to +180 °C/-40 to +356 °F

Material

- Probe shaft: Stainless steel
- Line: Sheathed, FEP
- Connector: ABS plastic

Accuracy (at 25 °C/77 °F)*

- Humidity
 - $\pm (1.0 \% \text{ RH} + 0.007 \times \text{reading})$ for 0 to 90 % RH
 - $\pm (1.4 \% \text{ RH} + 0.007 \times \text{reading})$ for 90 to 100 % RH
 - 0.02 % RH/K, dependent upon the process temperature (with a deviation of 25 °C/+77 °F)
 - 0.02 % RH/K, dependent upon the electronics temperature (with a deviation of 25 °C/+77 °F)
 - Temperature
 - $\pm 0.15 \text{ }^\circ\text{C}$ (0.27 °F) with slope PT1000 DIN 1/3 class B
- * Refer to the charts below for the correlation between temperature and accuracy.

Reproducibility

- Better than $\pm 0.2 \% \text{ RH}$

Sensor

- Response time without protective filter: t 90 max. 15 sec.

Probe dimensions

- Diameter of probe shaft: 12 mm
- L = approx. 120/200/300/500/800 mm
- L – A = 85/165/265/465/765 mm
- A, see Table Protection caps, page 86

Probe length incl. probe shaft and filter

- 1/2/5/10 m

Pressure resistance**

- PN 10 (probe tip)
- PN 1 (if end of probe/cable is involved in process)

** If installing probe under pressure, please use cutting ring screw connection (order no. 0554 1795).

Measuring accuracy of testo 6613 cable probe

Humidity error, absolute $|\pm\% \text{ RH}|$ as a factor of process humidity (% RH)

6611, 6612, 6613

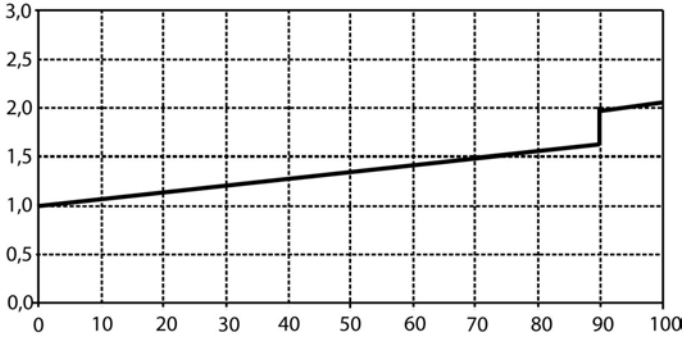

Temperature error as a factor of process temperature and temperature of electronics

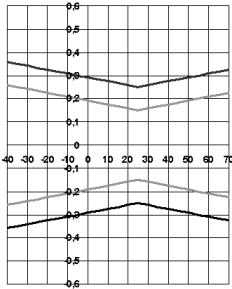

Grey line: System error 6383 + probe, electronics 25 °C/+77 °F

Black line: System error 6383 + probe, electronics -25 to 70 °C/-13 to 158° F

6.2.4. testo 6614 heated cable probe

The testo 6614 heatable probe is suitable for use in high-humidity processes in which there is the possibility of condensation for the probe.

i Also see volume 1, High-humidity adjustment for testo 6614, page 45 for the functional principle of the testo 6614.

At a glance

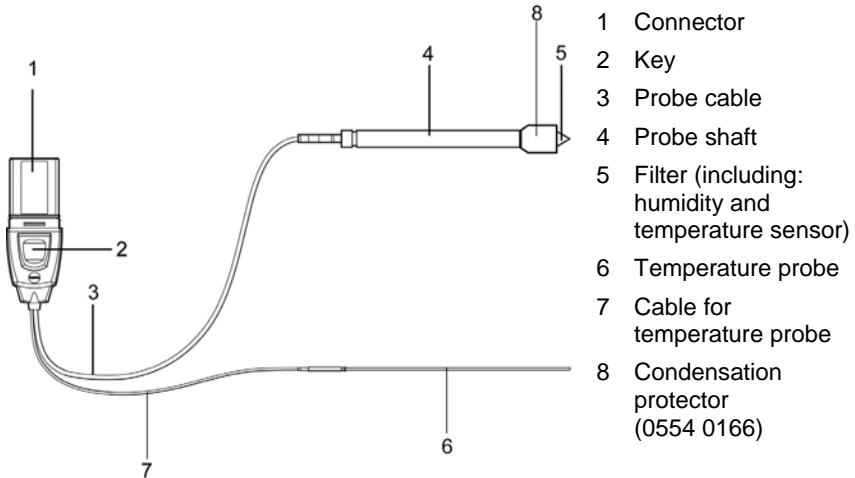

⚠ WARNING

In the event of overpressures, the probe may become a projectile.

> Mount the probe pressure-tight (see pressure resistance under Technical data)

Application

- Monitoring and regulating high-humidity processes, e.g. drying (ceramics, tobacco, wood, food) and maturing (cheese, fruit).
- At flow velocities > 1 m/s, an additional measuring uncertainty, not higher than +1.5 % RH, is to be expected. To prevent this error and ensure the highest measuring accuracy: Use condensation protector 0554 0166.

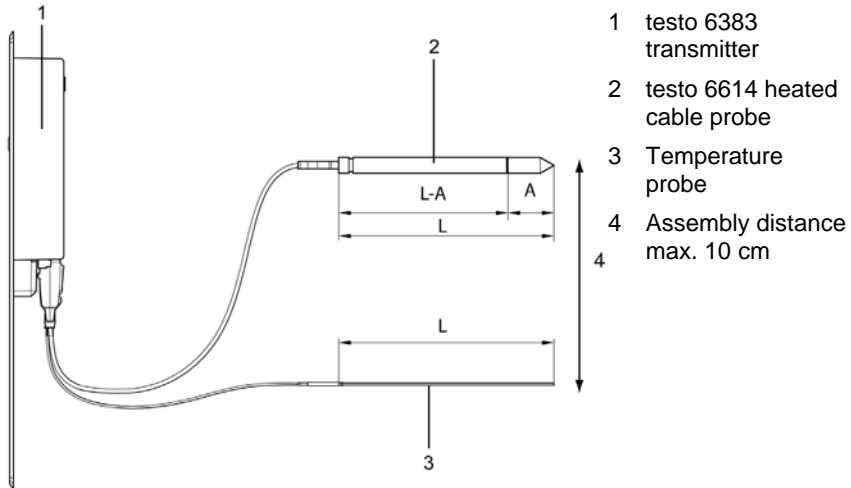

Technical data

Parameters

- Humidity
- Temperature

Measuring range

- Humidity: 0 to 100 % RH
- Temperature: -40 to + 180 °C/-40 to 356 °F

Material

- Probe shaft: Stainless steel
- Line: Sheathed, FEP
- Connector: ABS plastic

Accuracy (at 25 °C/77 °F)*

- Humidity (values valid when using condensation protector 0554 0166)
 - $\pm (1.0 \% \text{ RH} + 0.007 \times \text{reading})$ for 0 to 100 % RH
 - 0.02 % RH/K, dependent upon the process temperature (with a deviation of 25 °C/+77 °F)
 - 0.02 % RH/K, dependent upon the electronics temperature (with a deviation of 25 °C/+77 °F)
- Temperature
 - $\pm 0.15 \text{ °C} (0.27 \text{ °F})$ with slope PT1000 DIN 1/3 class B

* Refer to the charts below for the correlation between temperature and accuracy.

Reproducibility

- $\pm 0.2\%$ RH better

Sensor

- Response time without protective filter: t 90 max. 15 sec.

Probe dimensions

- Diameter of probe shaft: 12 mm
- Diameter of temp. probe: 3 mm
- L = approx. 200/500 mm
- L – A = 165/465 mm
- A, see Table Protection caps, page 86

Probe length incl. probe shaft and filter

- 1/2/5/10 m

Pressure resistance**

- PN 10 (probe tip)
- PN 1 (if end of probe/cable is involved in process)

** If installing probe under pressure, please use cutting ring screw connection (order no. 0554 1795).

Measuring accuracy of heated testo 6614 cable probe

Humidity error, absolute $|\pm\% \text{ RH}|$ as a factor of process humidity (% RH)

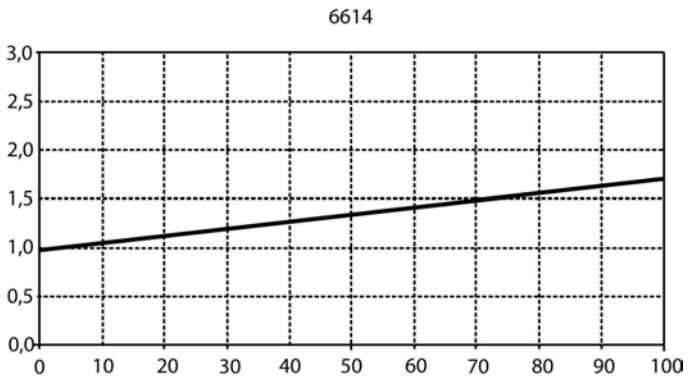

Temperature error as a factor of process temperature and temperature of electronics

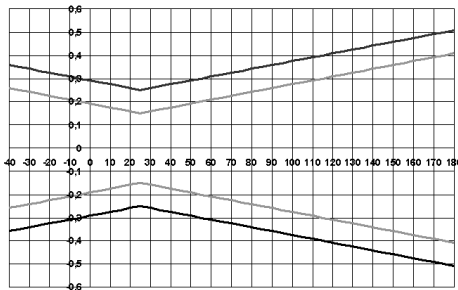

Grey line: System error 6383 + probe, electronics 25 °C/+77 °F

Black line: System error 6383 + probe, electronics -25 to 70 °C/-13 to 158° F

testo 6615 trace humidity cable probe (self-adjustment)

The testo 6615 probe corrects deviations in measurements by means of self-adjustment. This has a particular significance with low humidity values (in dewpoint range).



Also see volume 1, Self adjustment of testo 6615 trace humidity probe, page 46 for the functional principle of the testo 6615.

Only use testo 6615 with sintered PTFE protection cap (art. no. 0554 0758) or sintered stainless steel protection cap (art. no. 0554 0647).

During the self-adjustment phase the signal values of the analog outputs remain on hold, meaning they are frozen for the duration.

At a glance

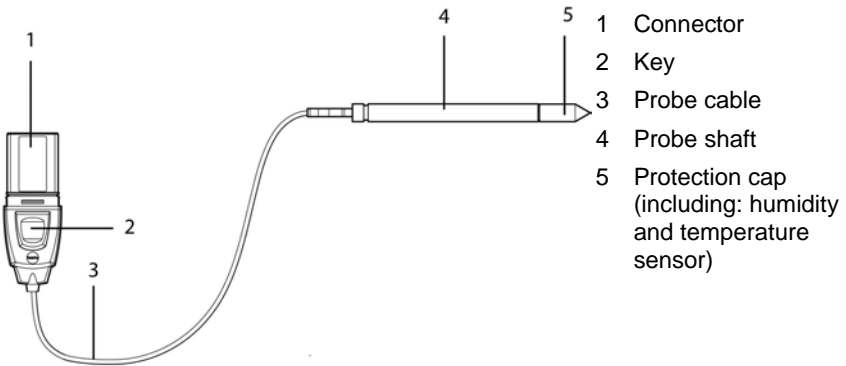

⚠ WARNING

In the event of overpressures, the probe may become a projectile.

> Mount the probe pressure-tight (see pressure resistance under Technical data)

Application

- Monitoring and regulating trace humidity processes (compressed air with adsorption or membrane driers and plastic granulate driers)
- Used when spatial separation of transmitter and probe is required.

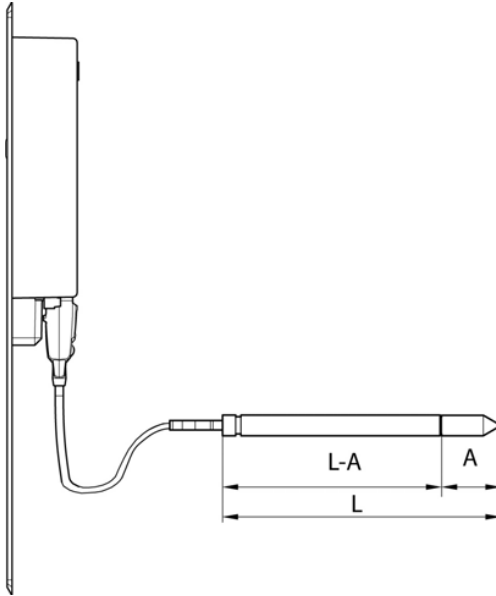

Technical data

Parameters

- Dewpoint
- Temperature

Measuring range

- Dewpoint: -40 to $+30$ °C_{td}/ -148 to $+212$ °F_{td}
- Temperature: -40 to ± 120 °C/ -40 to $+248$ °F
- (Temp. durability up to $+180$ °C/ $+356$ °F)

Material

- Probe shaft: Stainless steel
- Line: Sheathed, FEP
- Connector: ABS plastic

Accuracy (at 25 °C/77 °F)*

- Dewpoint
 - ± 1 K at 0 °C_{td}/ $+32$ °F_{td}
 - ± 2 K at -40 °C_{td}/ -40 °F_{td}
 - ± 4 K at -50 °C_{td}/ -58 °F_{td}
 - ± 6 K at -60 °C_{td}/ -76 °F_{td}

- Dependent on the process temperature (deviation of 25 °C / 77 °F)
 - ± 0.1 Ktd/K at -40 °C to 25 °C/-40 °F to +77 °F
 - ± 0.2 Ktd/K at 25 °C to 50 °C/77 °F to 122 °F
 - ± 0.4 Ktd/K at 50 °C to 120 °C/122 °F to 248 °F
 - Temperature
 - ± 0.15 °C (0.27 °F), slope PT1000 1/3 class B
- * Refer to the charts below for the correlation between temperature and accuracy.

Sensor

- Response time without protective filter: t 90 max. 15 sec.

Probe dimensions

- Diameter of probe shaft: 12 mm
- L = approx. 200/500 mm
- L – A = 165/465 mm
- A, see Protection caps, page 86.

Cable length incl. probe shaft and filter

- 1/2/5/10 m

Pressure resistance

- PN 16 (probe tip)**

** If installing probe under pressure, please use cutting ring screw connection (order no. 0554 1795).

Measuring accuracy of testo 6615 trace humidity cable probe

Dewpoint error, absolute $|\pm\% \text{ RH}|$ as a factor of process dewpoint ($^{\circ}\text{C}_{\text{td}}$)

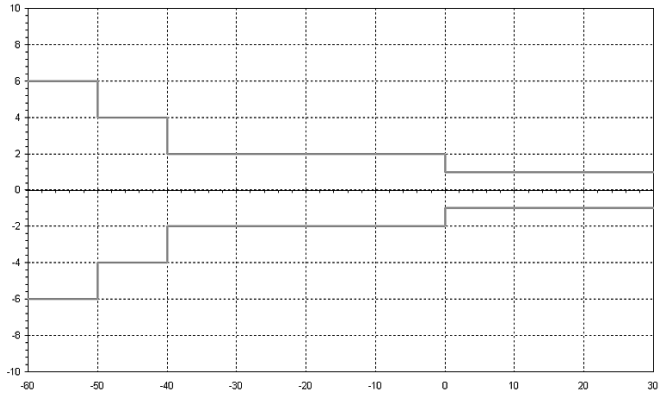

Temperature error as a factor of process temperature and temperature of electronics

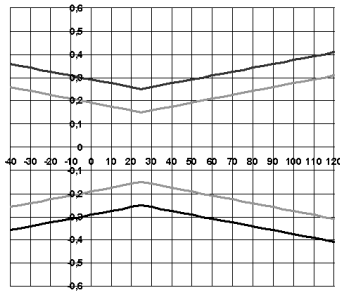

Grey line: System error 6383 + probe, electronics 25 °C/+77 °F

Black line: System error 6383 + probe, electronics -25 to 70 °C/-13 to 158° F

6.2.5. testo 6617 cable probe (self-monitoring)

The testo 6617 probe is used if spatial separation of the transmitter and probe is required, particularly for media (gases, vapours) which can jeopardize/damage the humidity sensor (the testo 6617 has a self-monitoring and early-warning function for such applications).

At a glance

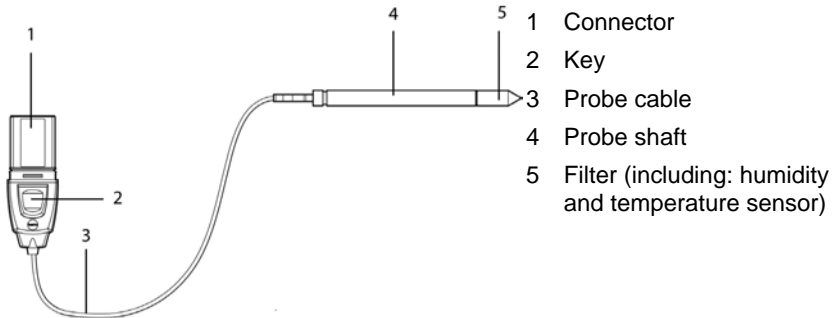

⚠ WARNING

In the event of overpressures, the probe may become a projectile.

> Mount the probe pressure-tight (see pressure resistance under Technical data)

Application

- Monitoring and regulating industrial humidity processes involving corrosive media (apart from high-humidity processes) with the exception of applications with HCL, HF and other acids and acidifiers in larger concentrations (SO₂, SO₃, NO₂)
- Meeting the top accuracy requirements
- Applications for which a sturdy metal housing is required

i This probe does NOT have a longer life with exposure to aggressive media than the testo 6613, for example. However, early warning of damage to the sensor is given so that machine failures can be avoided.

6.2.5.1. Self-monitoring of cover electrode

Use in harsh ambient conditions with aggressive media in some cases incurs the risk of damage to the sensor.

Damage to the sensor is generally reflected by incorrect readings which occur a long time before the sensor is wrecked. If this damage to the sensor is not spotted until too late, high costs can be incurred due to unusable readings or machine shutdowns and waiting times until the sensor is replaced.

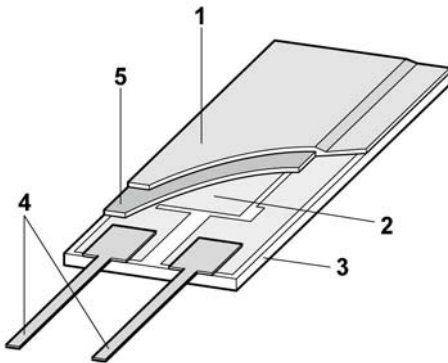

- 1 Cover electrode
- 2 Bottom electrode
- 3 Substrate (ceramic substrate for mechanical protection)
- 4 Connections (protected against corrosion)
- 5 Dielectric layer

The testo 6617 has a unique self-monitoring function.

This allows early detection of damage to the sensor, e.g.:

- Mechanical damage (e.g. scratches)
- Damage from aggressive gases (e.g. acids in aerosol form)
- Swelling or detachment of polymer layer due to effects of solvents

Once the self-monitoring reaches the specific limit value, the probe warning message "Sensor early warning" is issued.

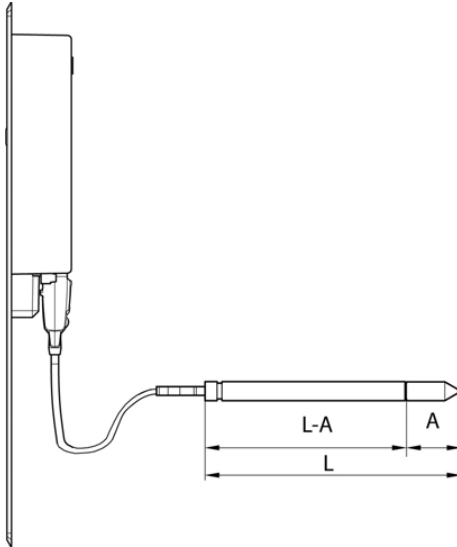

Technical data

Parameters

- Humidity (% RH/°C_{td}/°F_{td})
- Temperature

Measuring range

- Humidity: 0 to 100 % RH
- Temperature: -40 to +180 °C/-40 to 356 °F

Material

- Probe shaft: Stainless steel
- Line: Sheathed, FEP
- Connector: ABS plastic

Accuracy (at 25 °C/77 °F)*

- Humidity
 - $\pm (1.2 \% \text{ RH} + 0.007 \times \text{reading})$ for 0 to 90 % RH
 - $\pm (1.6 \% \text{ RH} + 0.007 \times \text{reading})$ for 90 to 100 % RH
 - 0.02 % RH/K, dependent upon the process temperature (with a deviation of 25 °C/+77 °F)
 - 0.02 % RH/K, dependent upon the electronics temperature (with a deviation of 25 °C/+77 °F)

- Temperature
 - ± 0.15 °C (0.27 °F) with slope PT1000 DIN 1/3 class B
 - * Refer to the charts below for the correlation between temperature and accuracy.

Reproducibility

- Better than ± 0.2 % RH

Sensor

- Response time without protective filter: t 90 max. 15 sec.

Probe dimensions

- Diameter of probe shaft: 12 mm
- L = approx. 200/500 mm
- L – A = 165/465 mm
- A, see Protection caps, page 86.

Probe length incl. probe shaft and filter

- 1/2/5/10 m

Pressure resistance

- PN 10 (probe tip)**

** If installing probe under pressure, please use cutting ring screw connection (order no. 0554 1795).

Measuring accuracy of testo 6617 cable probe (self-monitoring)

Humidity error, absolute $|\pm\% \text{ RH}|$ as a factor of process humidity (% RH)

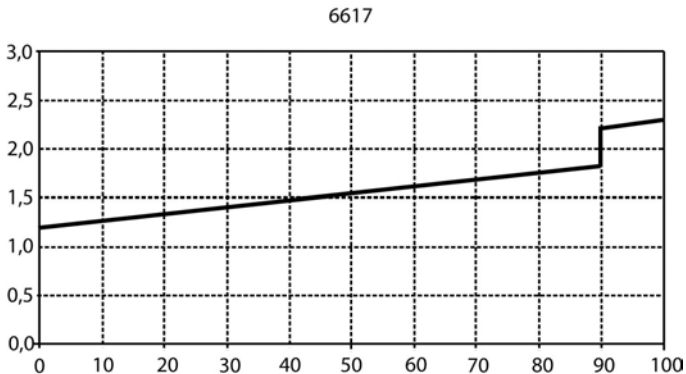

Temperature error as a factor of process temperature and temperature of electronics

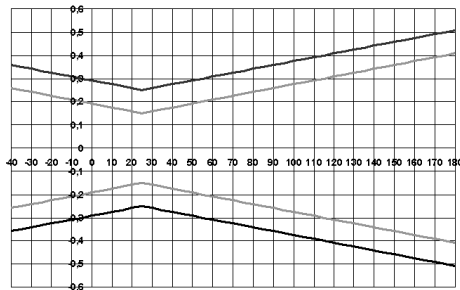

Grey line: System error 6383 + probe, electronics 25 °C/+77 °F

Black line: System error 6383 + probe, electronics -25 to 70 °C/-13 to 158° F

6.3. Commissioning

6.3.1. Installing the probe

6.3.1.1. Installing testo 6613/6614/6615/6617 probes

If used with these probes, the testo 6383 transmitter is mounted on the wall, see volume 1, **Fehler! Verweisquelle konnte nicht gefunden werden.**, page **Fehler! Textmarke nicht definiert.**

Install probe according to the application and the measuring and spatial conditions, cf. cases A1 to C below



In processes with which condensate forms at the humidity probe, install the probe vertically (filter points downwards).

A 1 Wall mounting of probe

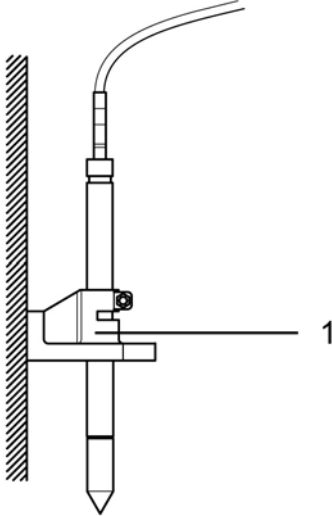

1 Wall/duct holder (order no. 0554 6651)

A 2 Wall mounting of testo 6614 heated probe

When mounting the testo 6614 heated probe version, the temperature probe must be secured as close to the humidity probe as possible (max. 10 cm). An appropriate assembly tool is supplied with the testo 6614.

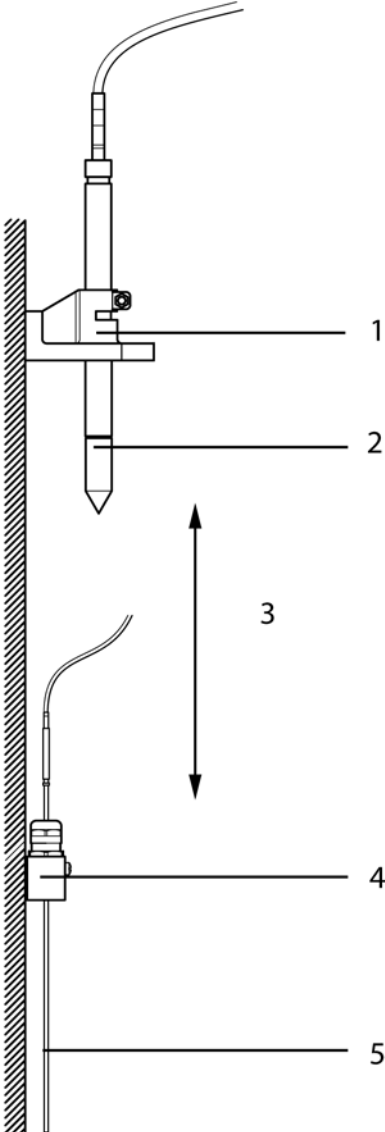

- 1 Wall/duct holder (order no. 0554 6651)
- 2 testo 6614
- 3 Distance of probe tips of humidity probe - temperature probe: As close as possible, but without touching (distance between probe tips max. 10 cm)
- 4 Assembly tool, supplied with the wall/duct holder (order no. 0554 6651)
- 5 Temperature probe

B Duct mounting of testo 6614 heated probe

When mounting the testo 6614 heated probe version, the temperature probe must also be secured at a distance of approximately 10 cm from the humidity probe. An appropriate assembly tool is supplied with the testo 6614.

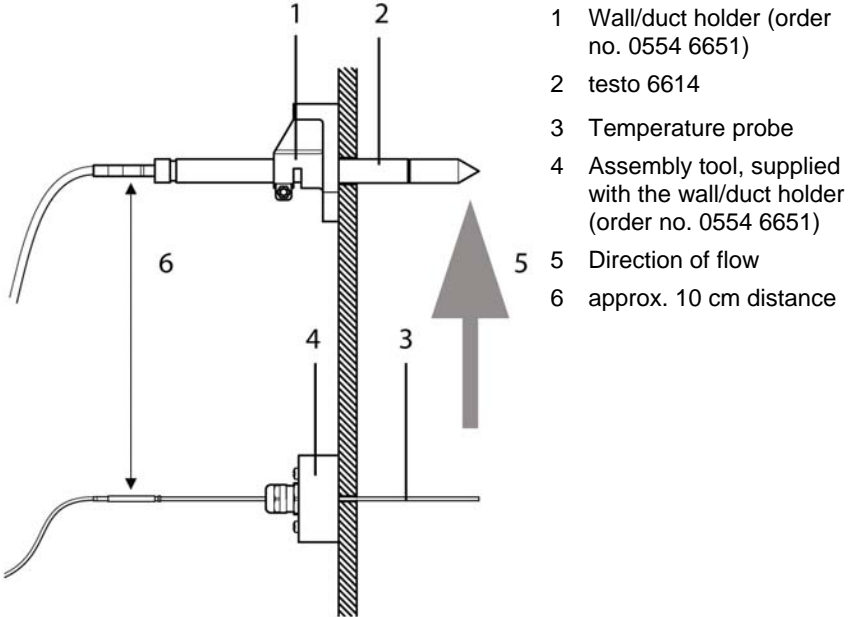

C Process mounting

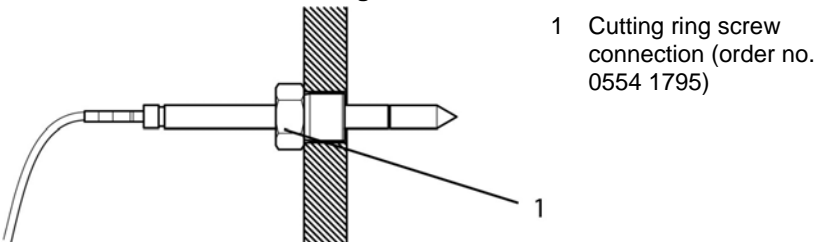

During installation, ensure that the probe cannot be damaged during operation.



For the testo 6614 (heated probe version), please use the cutting ring screw connection, order no. 0400 6193, to assemble the temperature probe.

6.3.2. Connecting/removing the probe to/from the transmitter

- Insert probe connector into socket of testo 6383 until it engages. The testo 6383 identifies which probe is connected.
- To remove the probe, the lock release button on the probe must be pressed so that this can be removed.

6.4. Maintenance and cleaning

6.4.1. Replacing filters/protection caps

6.4.1.1. Replacing the filter/protection caps for wall version

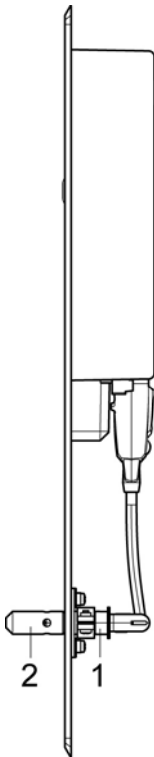

Do not damage the sensors when exchanging the filter/the protection cap and do not touch their surfaces!

1. Unscrew defective filter/protection cap (2) from probe shaft (1).

2. Screw new filter/protection cap onto probe shaft.

i Screw on protection cap by hand, i.e. do not tighten it using a tool.

6.4.1.2. Replacing the filter/protection cap for duct versions

i The following descriptions applies to these probes:

- testo 6613
 - testo 6614
 - testo 6615
 - testo 6617
-

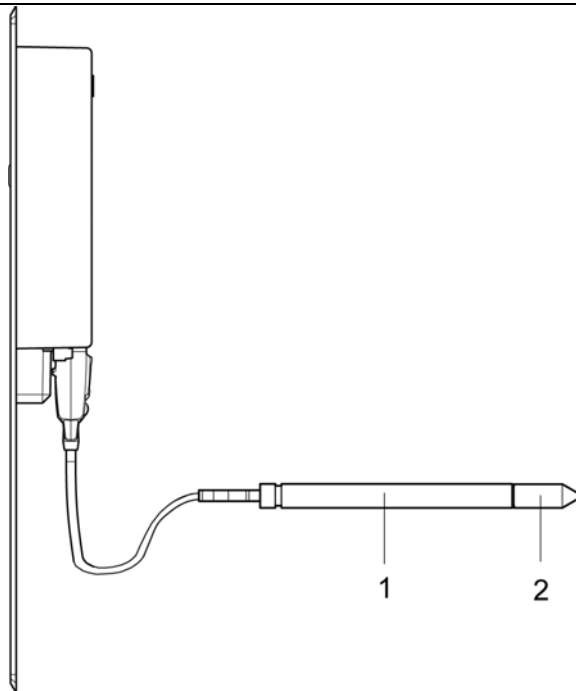

i Do not damage the sensor when exchanging the filter/the protection cap and do not touch its surface!

1. Unscrew defective filter/protection cap (2) from probe shaft (1).
 2. Screw new filter/protection cap onto probe shaft.
-

i Screw on protection cap by hand, i.e. do not tighten it using a tool.

6.4.2. Cleaning the instrument and filter/protection cap

- Only clean the instrument carefully with a moist cloth.
- Do not use aggressive cleaning agents.
- Do not use any solvents.
- Unscrew cap or protection cap to clean, clean with compressed air and replace. Take care not to damage the sensor!

6.4.3. Replacing the sensor

Thanks to the probe concept (digital, plug-in), all probes can be changed in situ within seconds if necessary, generally without any interruption to the operation of the machine.



To maintain the extremely high accuracy of the testo 6610 probe, it is not possible for customers to change the sensor. Please contact your Testo Service team for this.

7 Parameterizing, adjusting and analyzing software (P2A software)

7.1. Specifications

The P2A software is used for the parameterizing, adjustment and analysis of testo transmitters. The following applies:

- Generally, all newer testo transmitters (as of 2007) are supported.
- Included with every testo transmitter that is bought new is a CD that contains a free upgrade of the software, which includes the device drivers for all transmitters that can be attached at this time.
- This upgrade can be downloaded at any time via the testo homepage "www.testo.com/Download/P2A".

The software must only be bought one time, even for owners of several testo transmitters.

7.1.1. Functions and use

In the P2A software, two different file types are used: The instrument and the parameter file.

Instrument file

The parameters of a particular transmitter are stored in its so-called instrument file. Using this file, the parameters can be edited and the instrument can be tested and adjusted.

Instrument files also contain the respective histories in addition to the parameter data, i.e. "log books" are kept for the previous parameterizations, adjustments and messages (see Transmitter history page 139).



Instrument files are ".cfm" format files.

Parameter file

Parameter files are not tied to a specific individual transmitter and contain only parameter data/no history data.

If you use various instruments of the same type, you can create parameter files once (e.g. by saving the appropriate instrument file as the parameter file) and transmit these onto the other instruments.



Parameter files are ".cfp" format files.

7.1.2. System requirements

Operating system

- Windows® 2000 SP4
- Windows® XP Home/Professional
- Windows® Vista

Computer

- Pentium processor of at least 400 MHz or equivalent
- 128 MB RAM
- Graphics resolution of at least 1024 x 768
- Unused hard drive capacity of at least 15 MB
- CD-ROM drive
- USB interface
- At least Internet Explorer 5.0.

Software

The P2A software must be purchased and installed separately from the transmitter. If it is a new software version, the transmitter is already supported completely. Older P2A software versions can be updated via the P2A software upgrade (cf. product CD included with the transmitter).

7.1.3. Scope of delivery

Included in the scope of delivery are:

- P2A software
- USB driver



When working with the parameterizing, adjusting and analyzing software (P2A software), previous knowledge of Windows® operating systems is assumed. The description in this instruction manual relates to Windows® XP.

7.2. First steps

7.2.1. Installing the software/driver

i Administrator rights are required to install programs and drivers under Windows® 2000 SP4, XP and Vista.

7.2.1.1. Installing P2A software

1. Insert CD with P2A software.
 - ✓ If the installation program does not start automatically:
 - > Open Windows Explorer and start the file **Setup.exe** on the product CD.
2. Follow the directions of the installation wizard.

7.2.1.2. Installing USB driver

i Before installing the USB driver, please read the separate documentation that is enclosed with the USB driver CD.

7.2.1.3. P2A software upgrade

1. Insert product CD (supplied with the transmitter).
2. Open Windows® Explorer and start the file **P2A upgrade.exe** on the product CD.
3. Follow the directions of the installation wizard.

7.2.2. Starting the software

7.2.2.1. Starting the program

- > Select: **[Start] > All Programs > Testo > P2A Software.**
- The program window is opened (see User interface page 116).

7.2.2.2. Establishing a connection with the instrument

Multiple instruments can be attached, however only one connection is active at all times.

- ✓ USB driver is installed (see Installing USB driver page 115).
1. Start the P2A software.

2. Connect adapter (supplied with the P2A software) to the service interface of the instrument (see volume 1, Service interface page 15).
3. Connect instrument/adapter to the PC via the USB interface.
 - The instrument file of the attached instrument is shown in the file list.

7.2.2.3. Activating the connection with the instrument

- > Click on the desired instrument file.
 - The selected file is marked in colour and the connection with the instrument is activated.

If a connection with the instrument is established when the program is started, the corresponding instrument file is marked automatically.

7.3. Using the software

7.3.1. User interface

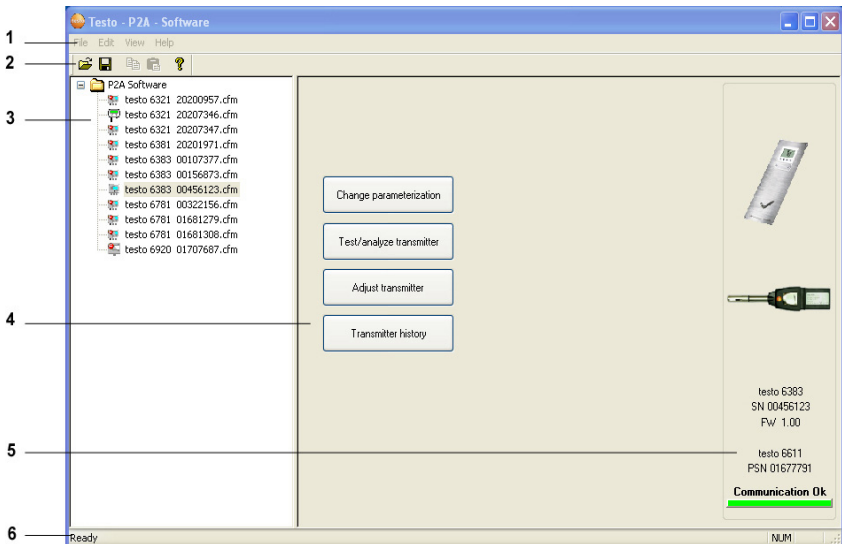



1 Menu bar:

Menu	Command	Explanation
File	Open	Shows the Windows dialogue for searching and opening files.
	Save as	Saves the parameters of an instrument or parameter file under a new name.
Edit	Copy	Copies the parameters of the marked instrument or parameter file in the cache.
	Paste	Pastes the parameters from the cache in the marked instrument or parameter file.
View	Toolbar Status bar	Activates/deactivates the toolbar or status bar.
?	Check instrument connections	Checks the connections to a connected instrument without the instrument having to be activated.
	Service	A text file with the most important information on the computer and the software is opened via Display service data .
	Information	Shows the version number of the P2A software.

2 Toolbar: Shows the Windows-compliant icons for editing.

3 File:

Icon	File	Explanation
 Symbol shows a transmitter	Instrument file	Instrument file Connection to the instrument has been established. <Type> <Serial number>.cfm File name should not be changed.
 Symbol shows a transmitter with a red minus sign in the upper left corner	Instrument file	Instrument file Connection to the instrument has not been established.

Icon	File	Explanation
 <p>Symbol shows a transmitter with a white P for parameter file in the upper left corner</p>	Parameter file	<p><Type> <Serial number> <Date> <Time>.cfp</p> <p>File name can be changed.</p> <p>The name can be selected freely, but it is recommended that you retain the reference to the instrument.</p> <p>Parameter files are always marked red; the parameter values they contain are only forwarded to the instrument after being transmitted to the instrument file.</p>

4 Function buttons: Dialogues on editing and testing the instrument are opened by means of the buttons.

[Change parameterization] see Changing instrument/parameter file page 119

[Test/analyze transmitter] see Chapter Analyzing/testing the transmitter page 130

[Adjusting the transmitter] see Chapter Adjusting the transmitter page 135

[Transmitter history] see Transmitter history page 139

5 File information:

Status	Shown in the window
An instrument file is selected	Type, serial number, firmware version of the instrument.
A parameter file is selected	Type, serial number and firmware version of instrument for which the parameter file was created.
Connection status	Green = connection is active Red = connection is inactive

6 Status bar: Shows the current status when editing via the menu bar.

7.3.2. Editing instrument/parameter file

7.3.2.1. Changing instrument/parameter file

✓ The desired instrument/parameter file is marked.

1. Click on **[Change parameterization]**.

- The **Properties of <Instrument type> <Serial number>** dialogue is opened with the **Change parameterization** register.

If the parameters were transmitted from other parameter files into the instrument file, a message is shown with which you can transmit the new parameters to the connected instrument using **[Yes]**.

> If the parameters should not be transmitted, click on **[No]**.

2. Change or enter parameters in the corresponding fields.

Field	Explanation
Unit/ Analog output	All analog outputs are parameterized in this mask.

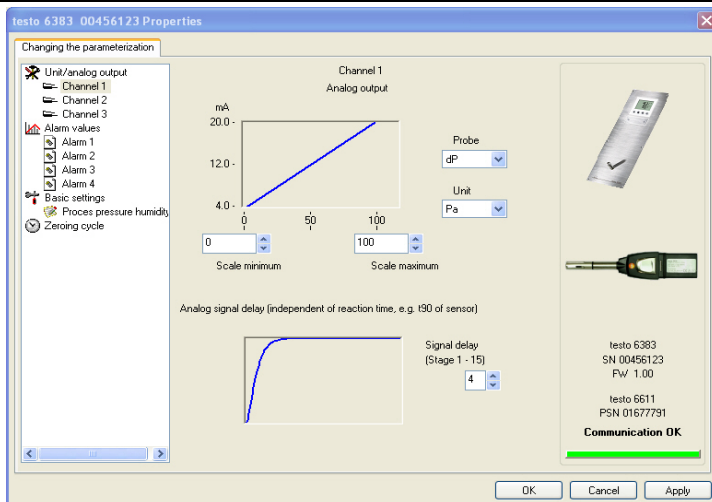

Field	Explanation
Unit/analog output (graphic)	<p>Unit: 0 to 1 V/5 V/10 V or 0 to 20 mA/4 to 20 mA.</p> <p>Vertical: Current version of the analog output (cannot be changed).</p> <p>Horizontal: Min./max. scale end points of selected unit.</p> <p>The curve changes in accordance with the entered value of scale minimum and maximum.</p>
Scale minimum/maximum	<p>The endpoints of the scaling can be selected up to the stored scale minimum and maximum. In the process, scaling can take place beyond the measuring range in order to adjust the analog output to the customer system, see volume 1, Scaling, page 17</p>
Unit	<p>Selection of the physical unit.</p> <p>When changing the unit, standard values are set for scale minimum and maximum.</p> <p>Caution!</p> <p>When changing the phys. unit, the relay limit values are set to the assigned default values.</p>
Signal delay (graphic)	<p>Curve changes according to the set signal delay.</p>
Signal delay	<p>Time interval in stages 1 – 15:</p> <p>1 = no delay</p> <p>15 = longest delay.</p> <p>The signal delay is added to the reaction time of the sensor. The signal delay shows averaging over the time interval of the selected stage in seconds:</p> <p>Example</p> <p>Stage 10 = average of the readings from the last 10 seconds.</p>

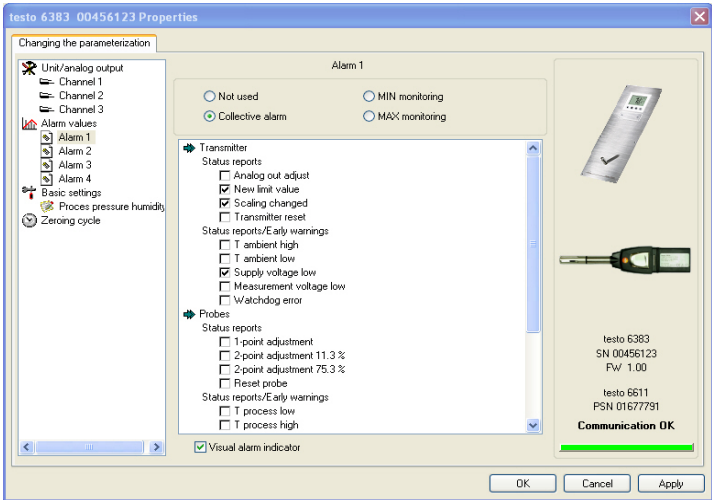

The delay of the signal in relation to the change in the process is also significantly influenced by the selection of the particle filter.

Field	Explanation
Limit values, relay 1 to 4/alarm values, alarm 1 to 4	In this mask, the relays or display alarms are parameterized.
	
Relay x/alarm x	Four relays or alarm values are available (optional).
Not used	Relay is not used. Hysteresis image and input options are hidden.
Collective alarm	A relay can be used as a collective alarm detector in the event that selected messages appear. Selection of the messages (OR linkage) by selecting the checkbox.
Min control	If switched to ON (NO contact) or OFF (NC contact) under the limit value; in the event of a subsequent exceeding of Limit value plus Hysteresis , it is switched to OFF (NO contact) or ON (NC contact).

Field	Explanation
Max control	If switched to ON (NO contact) or OFF (NC contact) above the limit value; in the event of a subsequent undershooting of Limit value minus Hysteresis , it is switched to OFF (NO contact) or ON (NC contact).

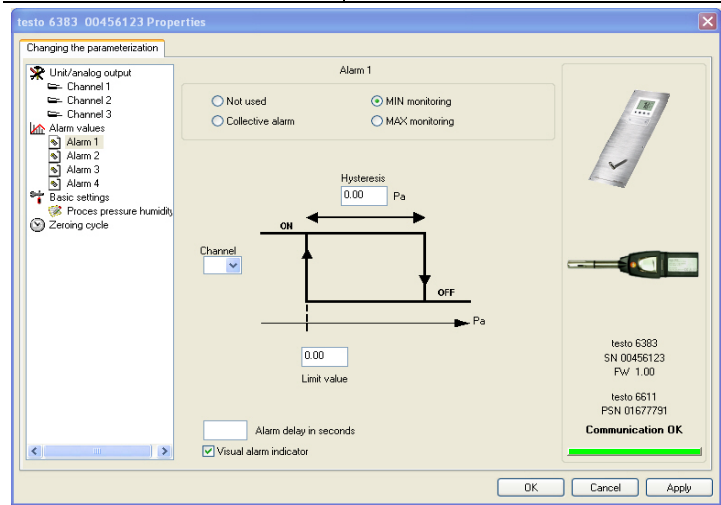

i The graphic display in the centre of the screen refers to the relay wiring as a NO contact (ON).

Hysteresis	To avoid switching cycles.
Channel	Selection of the channel that is to be monitored.
Limit value	Values for the limits of the unit selected in Unit/analog output ; 4 decimal places. When changing the phys. unit, the relay limit values are set to the default values.
Visual alarm display	Checkbox is activated: Upon the appearance of the selected alarm, the background lighting of the display flashes.

Field	Explanation
Alarm delay	<p>The desired alarm delay for the alarms of the min/max control and the visual alarm is entered in the input field (0 to 240 seconds possible).</p> <p>The alarm delay has no effect on the collective alarms.</p>

Field	Explanation
Basic settings	Setting the absolute pressure and selection of the H ₂ O ₂ evaporation process for the parameter °C _{tm} .

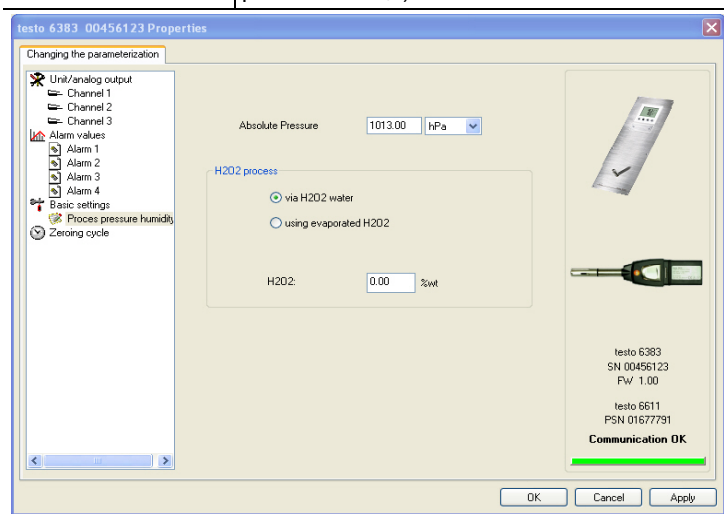

Absolute pressure	<p>The absolute pressure is included in the calculation of the following units:</p> <ul style="list-style-type: none"> • °C_{td} or °F_{td} • g/kg or gr/lb • ppmV% vol.
-------------------	---

Field	Explanation
H ₂ O ₂ process	<p>The calculation of the mixture dewpoint unit °C_{tm} is dependent upon the type of the evaporation process:</p> <ul style="list-style-type: none"> passive: H₂O₂ solution evaporates (via H2O2 water) active: H₂O₂ solution is evaporated over a heated metal plate (with evaporated H2O2) Input field: Entering the weight proportion of the liquid H₂O₂ compared to water in %.

Button	Explanation
Ethernet	Networking the transmitters via Ethernet. For a multitude of applications, measurement data can be simultaneously recorded, documented and visualized.

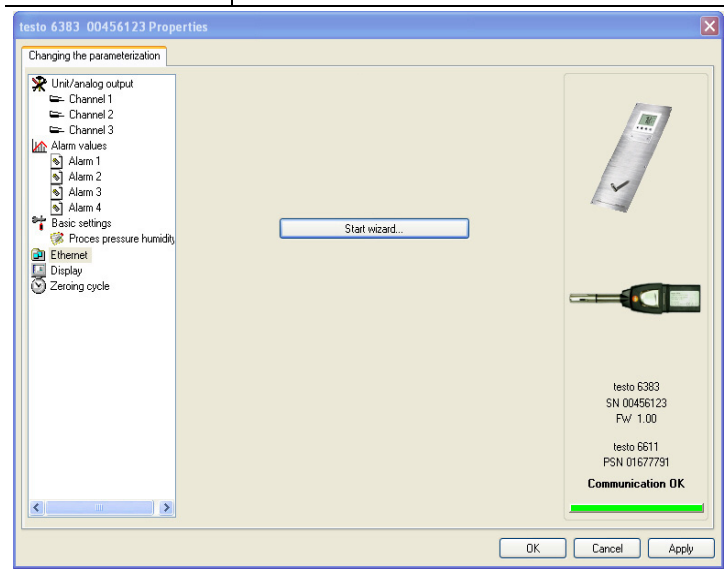

Start wizard...

Address allocation of the testo 6383 with Ethernet module:

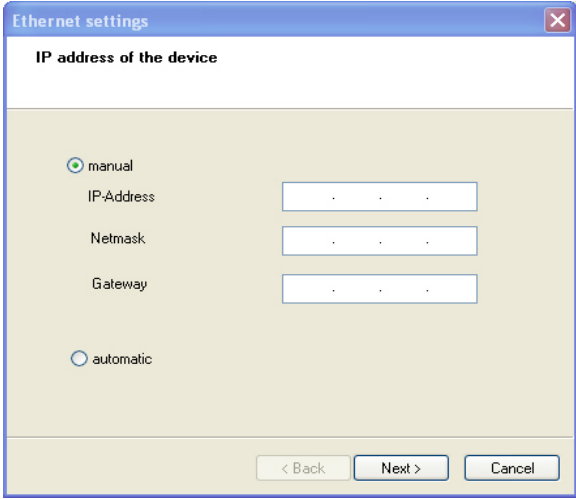
Button	Explanation
	
IP address	Transmitter IP address
<p>i</p>	<p>Prior to the automatic allocation of the IP address, the network cable must be connected to the transmitter.</p>
IP address of the device	Address allocation of the testo 6383 with Ethernet module:
Manual	<ul style="list-style-type: none"> • Define the IP address of the transmitter • Enter netmask • Enter gateway
Automatic	Automatic allocation of the IP address

Field	Explanation
Display	Setting the display functions (if a display is available on the transmitter).

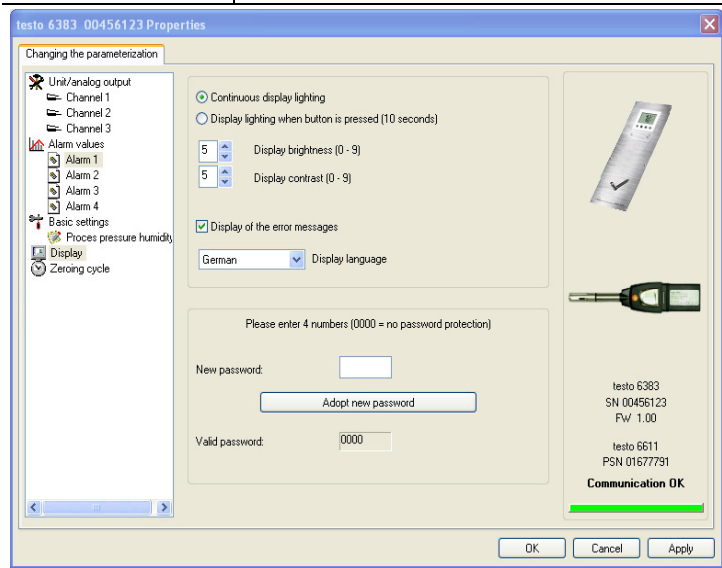

Continuous display lighting	Display lighting is permanently switched on.
Display lighting when button is pressed (10 seconds)	When a particular button on the instrument is pressed, the display lights up for 10 seconds.
Display brightness (0 to 9)	Setting the brightness between 0 and 9: 0 = dark 9 = light
Display contrast (0 to 9)	Setting the contrast between 0 and 9: 0 = low contrast 9 = high contrast
Display of the error messages	Selection of whether the error messages should be shown in the display.
Display language	Selection of the language.

Field	Explanation
New password	The password consists of four numbers, each of which must be between 1 and 9. If the password protection is not to be used, the numerical code "0000" must be entered.
[Adopt new password]	Button for confirming the new password.
Valid password	Display of the current password.
Field	Explanation
Zeroing cycle	Setting the interval of the automatic zeroing with solenoid valve.

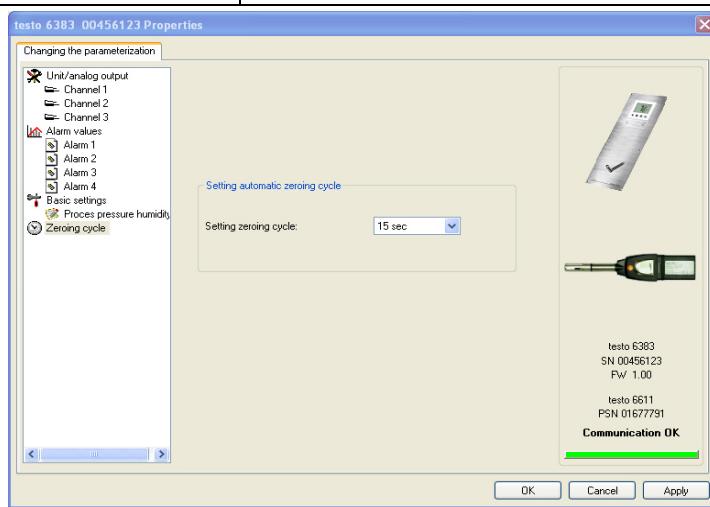

i The accuracy specifications are only valid for the zeroing cycle of 15 sec set by the factory.

Zeroing cycle setting	Selection of the time interval after which the automatic zeroing cycle is to occur. Recommendation: 15 sec
-----------------------	---

Field	Explanation
Self-adjustment	Setting the self-adjustment.

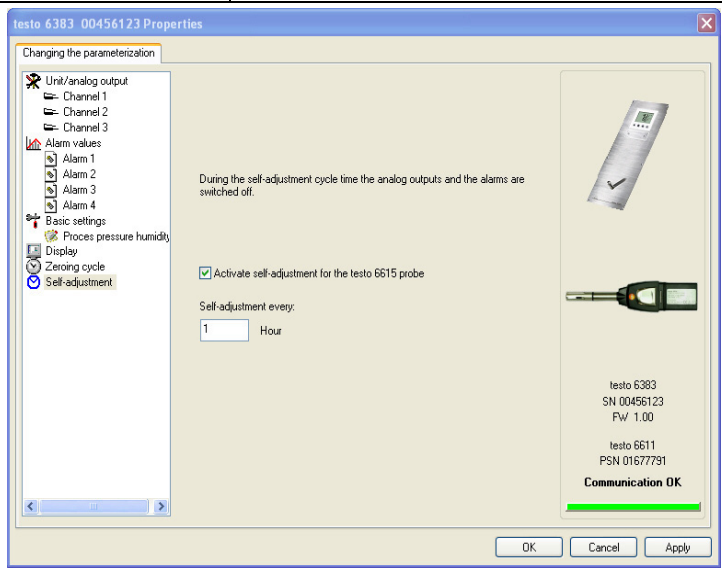

<p>Activate self-adjustment for the testo 6615 probe</p>	<ul style="list-style-type: none"> • Checkbox is activated: The self-adjustment is performed in the set cycle. • Checkbox is not activated: The self-adjustment is not performed.
--	---

<p>Self-adjustment every</p>	<p>Setting the cycletime in which the self-adjustment is to be performed.</p> <p>i In order to receive reliable readings during the calibration or equalization period of the probe, testo recommends the shortest possible cycle time.</p> <p>A longer cycle time can be set in continuous operation.</p>
------------------------------	---

7.3.2.2. Saving parameters

Parameters can be saved in new parameter files.

1. Mark instrument/parameter file.
2. Click on **File > Save as** in the menu bar.
3. Select storage location and enter the file name.
4. Click on **[Save]**.
 - The new parameter file is shown in the file list.

Only the parameters are saved from an instrument file; the history data are not adopted.



The original name (Instrument type, Serial number) is suggested with the current date/time as standard, e.g. "testo 6383 01234578 061120 1403.cfp".

For a standard installation, the files are saved under "C:\Documents and Settings\All Users\Shared Documents\P2A Software". The path can differ depending on the version of the operating system.

7.3.2.3. Opening the parameter file

All parameter files stored in the standard directory path are automatically displayed in the file list when the software is started.

You can also open parameter files that are stored in other directories.

1. Click on **File > Open** in the menu bar.
2. Select the storage location and click on the requisite file.
3. Click on **[Open]**.
 - The selected file is opened. This can be changed and saved (see Editing instrument/parameter file page 119).

7.3.2.4. Copying and pasting parameters

The parameters of a parameter file can be transmitted to an instrument file or another parameter file from the same instrument type.

1. Select file from which parameters are to be copied.
2. Click on **Edit > Copy** in the menu bar.
3. Select the file which is to be modified.
4. Click on **Edit > Paste** in the menu bar.
 - The parameters are transmitted to the file.



You can also use the common keyboard shortcuts for copying (CTRL+C) and pasting (CTRL+V).

Parameters can also be transmitted using drag & drop, where you drag the icon of the parameter file onto the icon of the target instrument file.

5. Connect and select corresponding instrument.
6. Click on **[Change parameterization]**.
7. Confirm confirmation request.
 - Parameter data are transferred to the instrument.

7.3.2.5. Deleting instrument/parameter file

Instrument/parameter files can be deleted from the file list.

1. Click on the file that is to be deleted with the right mouse button.
2. Select the command **Delete** in the context menu.
 - The instrument or parameter file is deleted from the list.

7.3.2.6. Creating a new instrument file

It is possible to create an instrument file without restarting the P2A software.

- ✓ Transmitter must be connected.
- 1. Click on **File > New connection** in the menu bar.
 - Connection to the transmitter is established.

7.3.3. Analyzing/testing the transmitter

In this section, you can test the outputs of the connected instrument, read off the limit values and reset the parameters to the factory settings.

The function is only available for instrument files.

7.3.3.1. Analyzing/testing the instrument

- ✓ The required instrument file is marked.
- 1. Click on **[Test/analyze transmitter]**.
 - The **Properties of <Instrument type> <Serial number>** dialogue is opened with the **Test/analyze transmitter** register.
- 2. Perform action:

Action	Explanation
Carrying out factory reset	Reset the unit, limit value and hysteresis parameters to factory settings (see below).
Testing analog output	Test channel 1/optional 2/3 (see Testing analog output, page 131).
Test switch outputs	Manually switch relays 1 to 4 to test for proper function (see Testing switch output relays 1 to 4, page 133).
Display min./max. values	Overview of the minimum and maximum values measured since the last reset of the transmitter (see Displaying min./max. values, page 134).

3. Click on **[OK]** or **[Cancel]** to close the dialogue.

7.3.3.2. Carrying out factory reset

- ✓ The required instrument file is marked.
- 1. Click on **[Test/analyze transmitter]**.
 - The **Properties of <Instrument type> <Serial number>** dialogue is opened with the **Test/analyze transmitter** register.
- 2. Mark transmitter test.
 - Current operating hours are shown.
- 3. Confirm control query to perform the reset.
 - The values are reset to the customer-specific factory settings.
- 4. Click on **[OK]** or **[Cancel]** to close the dialogue.

7.3.3.3. Testing analog output

- ✓ The required instrument file is marked.
- 1. Click on **[Test/analyze transmitter]**.
 - The **Properties of <Instrument type> <Serial number>** dialogue is opened with the **Test/analyze transmitter** register.
- 2. Mark channel and test values.

Field/button	Explanation
	Check the analog outputs (see volume 1, Editing Main Menu Analysis page 58).

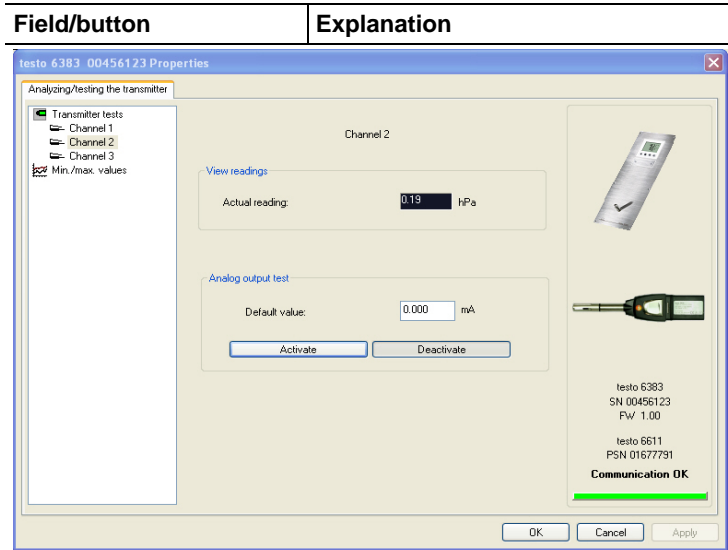

3. Click on **[OK]** or **[Cancel]** to close the dialogue.

- The analog output and the relay return to Measuring Mode again.

7.3.3.4. Testing switch output relays 1 to 4

- ✓ The required instrument file is marked.
- 1. Click on **[Test/analyze transmitter]**.
 - The **Properties of <Instrument type> <Serial number>** dialogue is opened with the **Test/analyze transmitter** register.
- 2. Mark **Relay tests** and test the values.

Field/button	Explanation
	Test the relay function (see volume 1, Editing Main Menu Analysis, page 58).

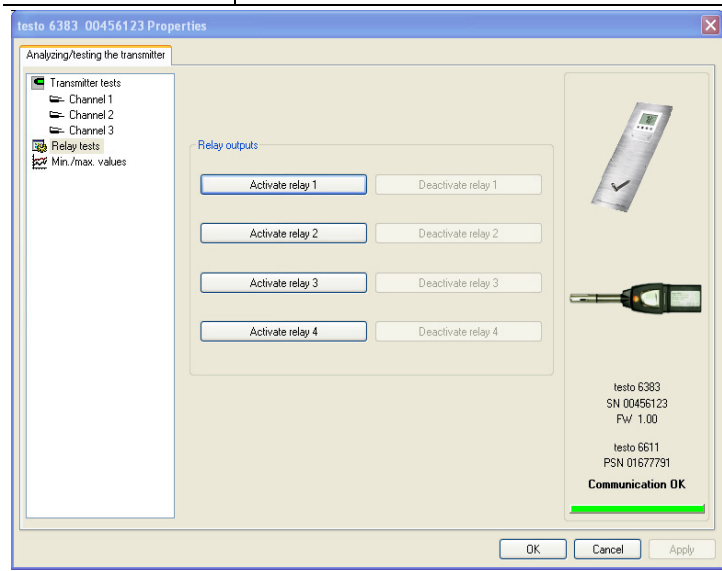

[Activate relay n]	<p>Close contact.</p> <p>A warning informs that the value is being transmitted to a connected PLC, external display, etc. in the event of existing cabling.</p>
[Deactivate relay n]	<p>Open contact.</p> <p>A warning informs that the value is being transmitted to a connected PLC, external display, etc. in the event of existing cabling.</p>

- 3. Click on **[OK]** or **[Cancel]** to close the dialogue.
 - The analog output returns to Measuring Mode again.

7.3.3.5. Displaying min./max. values

The transmitter saves the minimum or maximum value for each channel (measured since the last voltage supply or since the last manual reset).

✓ The required instrument file is marked.

1. Click on [Test/analyze transmitter].
 - The **Properties of <Instrument type> <Serial number>** dialogue is opened with the **Test/analyze transmitter** register.
2. Mark **Min./max. values**.

Field/button	Explanation
Min./max. values	View the min./max. values of each channel. Only the values within the measuring range are shown.

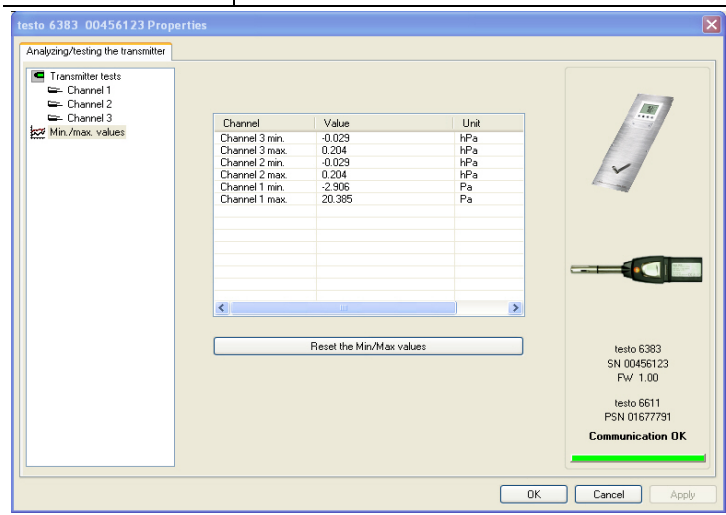

Channel	Min./max. of channel 1/2/3 (optional)
Value	Min. or max. value, 1 decimal place.
Unit	Unit selected in Unit/analog output .

3. Reset **Min./max. values**.
4. Click on [**Reset min./max. values**].
5. Confirm control query to perform the reset.
 - The values are reset to the factory settings.

6. Click on **[OK]** or **[Cancel]** to close the dialogue.

7.3.4. Adjusting the transmitter

This function is used to adjust an attached instrument. The following adjustments may be carried out using the software:

- 1-point adjustment (offset)
- Analog adjustment (entry via assistant/wizard)
- n-point adjustment (entry via assistant/wizard)

Also see volume 1, Adjusting the instrument, page 39.

7.3.4.1. 1-point adjustment



The testo 400/650 with precision humidity probe (order no. 0636 9741) is recommended as the reference measuring instrument for 1-point adjustment (offset) (see Adjusting testo 6383 using testo handheld instrument, page 41).

1. Expose the reference measuring instrument and the instrument to be adjusted to the same constant conditions and wait for equalization period to lapse.
2. Mark the instrument file of the connected instrument.
3. Click on **[Adjusting the transmitter]**.
 - The **Properties of <Instrument type> <Serial number>** dialogue is opened with the **Adjusting the transmitter** register.
4. Enter reference value and click on **[Carry out 1-point adjustment]**.
5. Confirm confirmation request.
 - The adjustment is carried out.

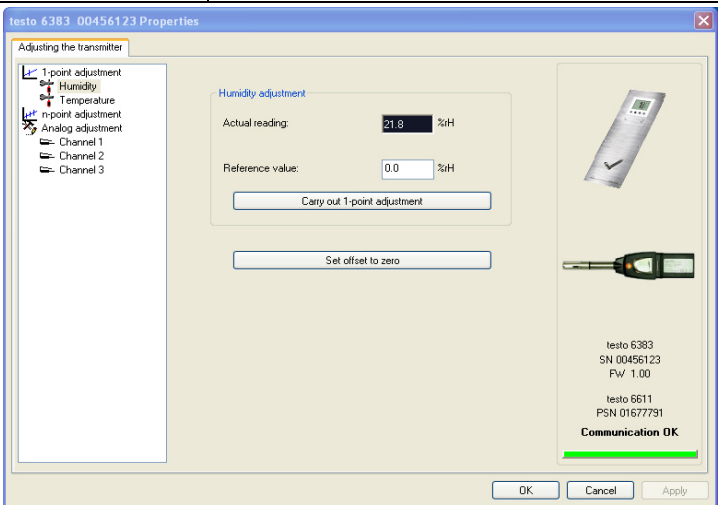
Field	Explanation
	
°C/°F	Selection of the unit; only for temperature adjustment.
Current reading	Reading in °C/°F or % RH. Readings are updated every second.
Reference value	Entry of the read-off value from the reference measuring instrument. Permissible entries: <ul style="list-style-type: none"> • max. 5 % RH deviation (sum of all 1-point adjustments) • max. 2 K (°C) deviation (sum of all 1-point adjustments)

> Click on **[Set offset to zero]** to reset a transmitted reference value.

- The current reading is used again.

6. Click on **[OK]** or **[Cancel]** to close the dialogue.

7.3.4.2. n-point adjustment

1. Connect precision pressure sensor (see volume 1, n-point adjustment (pressure), page 44).
2. Mark the instrument file of the connected instrument.
3. Click on **[Adjusting the transmitter]**.
 - The **Properties of <Instrument type> <Serial number>** dialogue is opened with the **Adjusting the transmitter** register.
4. Mark **n-point adjustment**.
5. Click on **[Start wizard ...]** and follow the instructions of the wizard.
 - The adjustment is performed when the wizard is closed.

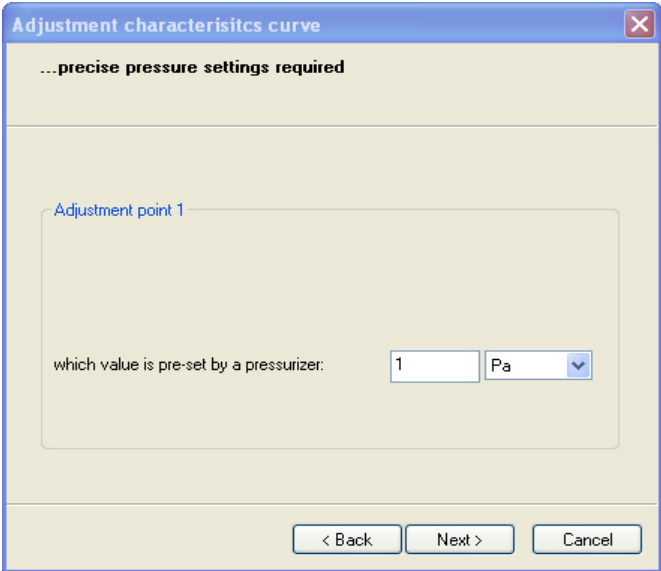
Field	Explanation
	<p>How much pressure is actually applied</p>

Required field: Entry of the value read off at the pressure sensor.

i The n-point adjustment must always be carried out to its full extent and in good time at all selected adjustment points.

i The number of adjustment points (3 to 6) is stored in the user menu of the transmitter and can only be changed via the P2A software.

7.3.4.3. Adjusting the analog output

1. Connect precision multimeter (see volume 1, Analog output adjustment, page 43).
2. Mark the instrument file of the connected instrument.
3. Click on **[Adjusting the transmitter]**.
 - The **Properties of <Instrument type> <Serial number>** dialogue is opened with the **Adjusting the transmitter** register.
4. Click on **[Start wizard ...]** and follow the instructions of the wizard.
 - The adjustment is performed when the wizard is closed.

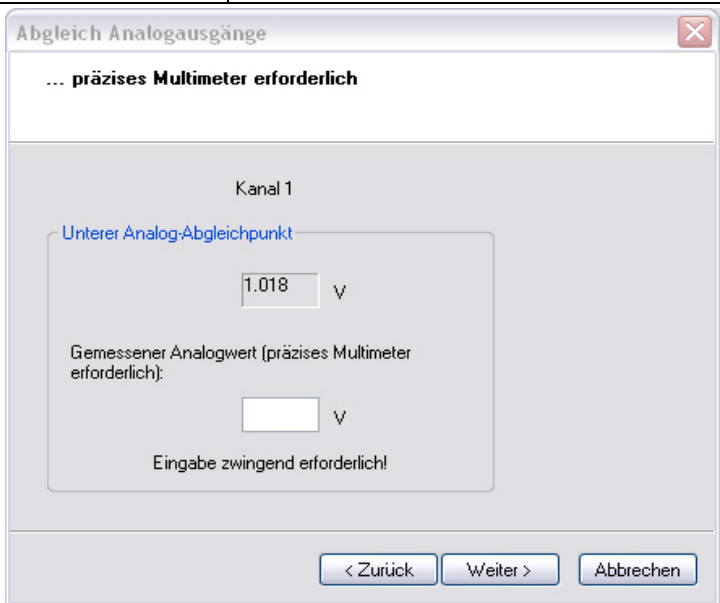
Field	Explanation
	

Field	Explanation
Default value	<p>The analog output value from the last performed adjustment is given at the output. Value of the factory adjustment:</p> <ul style="list-style-type: none"> • Lower adjustment point: approx. 10 % of the max. value • Centre adjustment point: approx. 50 % of the max. value • Upper adjustment point: approx. 90 % of the max. value
Measured analog value	Required field: Entry of the value read off at the multimeter.

7.3.5. Transmitter history

Parameterizations, adjustment processes and messages that have occurred are registered in the transmitter with an operating hours stamp.

In the history overviews (explained later in more detail), past processes and events can be made visible.



For parameter changes or adjustments that are performed directly at the instrument (via the user menu), "Transmitter" is entered in the User field and only the operating hour is entered in the Date/time field instead of operating hour/date/time.

For entries that are performed using the P2A software, the name of the user logged into Windows appears in the User field, while the date/time and operating hour are shown in the Date/time field.

1. Mark the instrument file of the connected instrument.
2. Click on the **[Transmitter history]** button.
 - The **Properties of <Instrument type> <Serial number>** dialogue is opened with the **Transmitter history** register.
3. Click on the required entry in the list to change the display.

Field	Explanation
Operating hours / date/time	Operating hour/time stamp at which the change at the instrument was performed.
User	Name with which the user is logged into the operating system. "Transmitter" entry if the change was performed at the instrument.
Comments	Type of parameter change, e.g. "Unit of channel 1 from Pa to hPa".

Field	Explanation

Selection of adjustment histories: **1-point adjustments / Analog adjustments / n-point adjustments.**

Serial no. Probes	Serial number of the probe.
Probe operating hour	Operating hour of the probe at which the change at the instrument was performed.
User	Name with which the user is logged into the operating system. "Transmitter" entry if the change was performed at the instrument.
Reference value	If no changes were performed, no value is displayed.
Unit	Unit during the adjustment.
Reading	1-point adjustment: If no changes were performed, no value is displayed.
Offset from	1-point adjustment: Value before the adjustment.
Offset to	1-point adjustment: Value after the adjustment.
Pressure specification	n-point adjustment: Reference value set at the pressure sensor.
Channel	Analog adjustment: Channel 1 to n.

Field	Explanation
Specification	Analog adjustment: Actual value.
Multimeter	Analog adjustment: Reference value set at the multimeter.
Offset	Analog adjustment: Deviation at time of adjustment.

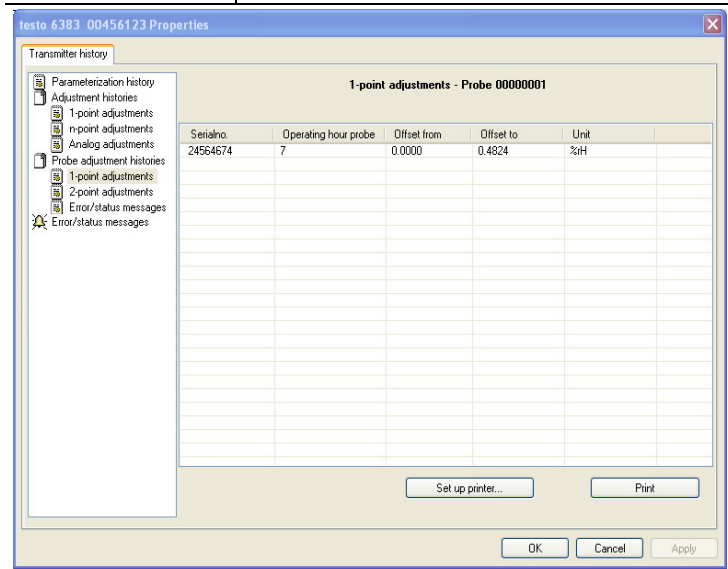

Selection of probe adjustment histories: **1-point adjustments** / **2-point adjustments** / **Error/status messages**.

Serial number	Serial number of the transmitter to which the probe was connected at the time of the adjustment.
Operating hour probe	Operating hour of the probe at which the change at the instrument was performed.
Unit	Unit during the adjustment.
Offset from	1-point adjustment: Value before the adjustment.
Offset to	1-point adjustment: Value after the adjustment.
Target value	2-point adjustment: Reference value.

Field	Explanation
Reading	2-point adjustment: Value before the adjustment.
Difference	2-point adjustment: Difference determined by instrument between target value and reading.
Error/status messages	Error/status messages: The error/status messages assigned to the probe.

Operating hour	Serialno.	Message	Type of message
0	20207739	Init sensor	Status reports
0	00000000	Init sensor	Status reports
0	20207739	Init sensor	Status reports
0	00000000	Init sensor	Status reports
0	20207739	Init sensor	Status reports
0	20207739	Transmitter reset	Status reports
0	00000000	Init sensor	Status reports
0	00000000	Transmitter reset	Status reports
0	00000000	Init sensor	Status reports
0	00000000	Transmitter reset	Status reports
0	00000000	Init sensor	Status reports
0	00000000	Transmitter reset	Status reports
0	00000000	Init sensor	Status reports
0	64582156	Init sensor	Status reports
0	64582156	Init sensor	Status reports
0	64582156	Transmitter reset	Status reports
0	00000000	Init sensor	Status reports
0	00000000	Init sensor	Status reports
0	00000000	Init sensor	Status reports
0	00456123	Init sensor	Status reports
0	00456123	Init sensor	Status reports
0	00000000	Init sensor	Status reports
0	00456123	Init sensor	Status reports

The table is shown only for error and status messages that were generated in the transmitter and were transferred and saved there via the connection to the P2A software.

Operating hours	Operating hour at which the message appeared in the instrument.
Serial number	Serial number of the instrument to which the message is assigned
Message	e.g. "Scaling changed". The scaling was changed.
Type of message	e.g. early warning, status message.

> To print out the history data, click on **[Print]**.



The printing job is automatically sent to the default printer for the operating system.

With **[Set up printer ...]** a different printer can be selected or the printout can be edited.

4. Click on **[OK]** or **[Cancel]** to close the dialogue.

8 Tips and assistance

8.1. Questions and answers

Question	Possible causes/solution
Connection to instrument cannot be established	Check connection cable/plug contacts
A message appears on the display	See volume 1, Status, warning and error messages, page 64
Malfunction (with and without display)	Analysis using the P2A software, see Analyzing/testing the transmitter, page 130
When does a stable current reading appear?	After approx. 20 seconds

If we could not answer your question, please contact your dealer or Testo Customer Service. For contact details see the rear side of this document or the web page www.testo.com/service-contact

8.2. Accessories and spare parts

i An overview of the probes that can be used with the testo 6383 can be found in volume 1, Overview of probe and filter types, page 84.

Description	Article no.
Spare parts	
Integrated humidity probe	0636 6610
Sealing frame	0554 6384
Protection Cap for the built-in humidity probe	0554 6385
Interface and software	
P2A software (parameterizing, adjusting, analyzing) incl. USB adapter	0554 6020
testo 400/650 adapter	0554 6022

Dewpoint measurement (only with testo 6615)	
Preliminary filter to protect measurement chamber and sensors against contamination	0554 3311
Precision chamber with adjustable inflow	0554 3312
Flow meter for measurement chamber for setting the specified inflow of the sensor	0554 3313
Cooling coil for process temperatures > 50 °C/122 °F (up to 200 °C/392 °F), only with precision measurement chamber	0554 3304
2 m PTFE tube with compressed air connections up to 140 °C/284 °F, max. 9000 hPa, only with precision measurement chamber	0699 2824
Protection caps	
Protection cap made of stainless steel (for integrated probe 0636 6610)	0170 0263
Protection cap made of stainless steel	0554 0647
Woven wire filter protection cap	0554 0757
Protection cap made of PTFE	0554 0758
Metal protection cap (open)	0554 0755
PTFE protection cap with condensate drip hole	0554 9913
Protection cap made of PTFE with condensation protector and condensate drip hole	0554 0166
Protection cap for H ₂ O ₂ atmospheres	0699 5867/1
Hoses	
Silicone hose ID 4 transparent	0086 0001, sold by the metre
TYGON hose ID 4.8 transparent	0086 0031, sold by the metre
Silicone hose transparent, internal diameter 2 mm, for test pressure connections 6383	0086 0003, sold by the metre
Supply	
Mains unit (desktop, wall-mounted)	0554 1748
Mains unit (top-hat rail mounting)	0554 1749

Extension and calibration cable	0554 6610
External display	
Process display for testo 54-2 AC....	5400 7553
Process display for testo 54-7 AC....	5400 7555
Calibration	
Standard ISO calibration certificate, transmitter only	0520 1000
Standard DKD calibration certificate, transmitter only	0520 1200
Standard ISO calibration certificate, transmitter + probes	0520 0176
Special ISO calibration certificate, transmitter + probes	0520 0066
Standard DKD calibration certificate, transmitter + probes	0520 0276
Special DKD calibration certificate, transmitter + probes	0520 0236
ISO calibration certificate humidity, probes	0520 0076
DKD calibration certificate temperature, probes	0520 0261

For a complete list of all accessories and spare parts, please refer to the product catalogues and brochures or look up our website at: www.testo.com

8.2.1. Ordering options for testo 6383 transmitter (0555 6383)

Order code	Characteristic
Axx Measuring range	
A01	0 to 50 Pa
A02	0 to 50 Pa
A03	0 to 100 Pa
A04	0 to 500 Pa
A05	0 to 10 hPa
A21	-10 to 10 Pa
A22	-50 to 50 Pa

Order code	Characteristic
A23	-100 to 100 Pa
A24	-500 to 500 Pa
A25	-10 to 10 hPa
Bxx Analog output/supply	
B02	0 to 1 V (4-wire, 24 V AC/DC)
B03	0 to 5 V (4-wire, 24 V AC/DC)
B04	0 to 10 V (4-wire, 24 V AC/DC)
B05	0 to 20 mA (4-wire, 24 V AC/DC)
B06	4 to 20 mA (4-wire, 24 V AC/DC)
Cxx Display	
C00	Without display
C02	With display/English
C03	With display/German
C04	With display/French
C05	With display/Spanish
C06	With display/Italian
C07	With display/Japanese
C08	With display/Swedish
Dxx Integrated humidity probe	
D00	No humidity/temperature probe
D04	Humidity/temperature probe integrated in panel
D05	Preparation for external humidity/temperature probe testo 6610 probe
Exx Ethernet	
E00	Without Ethernet interface

Order code	Characteristic
E01	With Ethernet interface
Fxx Differential pressure unit⁷	
F01	Pa/Min/Max
F02	hPa/Min/Max
F03	kPa/Min/Max
F04	mbar/Min/Max
F05	bar/Min/Max
F06	mmH ₂ O /Min/Max
F07	inchH ₂ O /Min/Max
F08	inch HG/Min/Max
F09	kg/cm ² /Min/Max
F10	PSI/Min/Max
Gxx Optional analog output for humidity probe connection test⁸	
G01	% RH/Min/Max
G02	°C/Min/Max
G03	°F/Min/Max
G04	°C _{td} /Min/Max
G05	°F _{td} /Min/Max
G06	g/kg /Min/Max
G07	gr/lb /Min/Max
G08	g/m ³ /Min/Max
G09	gr/ft ³ /Min/Max
G10	ppmV/Min/Max
G11	°C _{wb} /Min/Max
G12	°F _{wb} /Min/Max
G13	kJ/kg /Min/Max (enthalpy)

⁷ Scaling +/- 50 % of measuring range possible

⁸ Only if D04 or D05 is selected

Order code	Characteristic
G14	mbar/Min/Max (water vapour partial pressure)
G15	inch H ₂ O/Min/Max (water vapour partial pressure)
G16	°C _{tm} (dewpoint for H ₂ O ₂ mixture)
G17	°F _{tm} (dewpoint for H ₂ O ₂ mixture)
G18	% vol
Hxx Relay	
H00	Without relay
H01	4 relay outputs, limit value monitoring
H02	4 relay outputs, channel 1 limit values and collective alarm
Ixx Units, channel 3 (only if optional humidity probe connection is available)⁹	
I01	% RH/Min/Max
I02	°C/Min/Max
I03	°F/Min/Max
I04	°C _{td} /Min/Max
I05	°F _{td} /Min/Max
I06	g/kg /Min/Max
I07	gr/lb /Min/Max
I08	g/m ³ /Min/Max
I09	gr/ft ³ /Min/Max
I10	ppmV/Min/Max
I11	°C _{wb} /Min/Max
I12	°F _{wb} /Min/Max
I13	kJ/kg /Min/Max (enthalpy)
I14	mbar/Min/Max (water vapour partial pressure)

⁹ Only if D04 or D05 is selected

Order code	Characteristic
I15	inch H ₂ O/Min/Max (water vapour partial pressure)
I16	°C _{tm} (dewpoint for H ₂ O ₂ mixture)
I17	°F _{tm} (dewpoint for H ₂ O ₂ mixture)
I18	% vol
Kxx Languages of instruction manual	
K01	German/English instruction manual
K02	French/English instruction manual
K03	Spanish/English instruction manual
K04	Italian/English instruction manual
K05	Dutch/English instruction manual
K06	Japanese/English instruction manual
K07	Chinese/English instruction manual
K08	Swedish/English instruction manual

8.2.2. Ordering options for testo 6610 probes (0555 6610)

Order code	Characteristic
Lxx Probe type	
L12	Probe 6612
L13	Probe 6613
L14	Probe 6614
L15	Probe 6615
L17	Probe 6617
Mxx Protection caps	
M01	Protection cap made of stainless steel
M02	Protection cap made of wire mesh
M03	Protection cap made of PTFE
M04	Metal protection cap (open)
M06	PTFE protection cap with condensate drip hole

Order code	Characteristic
M07	Protection cap made of PTFE with condensate drip hole and condensation protector
M08	Protection cap for H ₂ O ₂ atmospheres
Nxx Cable length	
N02	1 m cable length (testo 6613, 6614, 6615, 6617)
N03	2 m cable length (testo 6613, 6614, 6615, 6617)
N04	5 m cable length (testo 6613, 6614, 6615, 6617)
N05	10 m cable length (testo 6613, 6614, 6615, 6617)
N06	Cable length specifically for duct versions (testo 6612)
Pxx Probe length	
P12	Probe length approx. 120 mm (testo 6613)
P20	Probe length approx. 200 mm (testo 6612, 6613, 6614, 6615, 6617)
P30	Probe length approx. 300 mm (testo 6612, 6613)
P50	Probe length approx. 500 mm (testo 6612, 6613, 6614, 6615, 6617)
P80	Probe length approx. 800 mm (testo 6612, 6613)

