

## **testo 6383 Ethernet - differential pressure transmitter**

testo 6610 - Probes

P2A software - Parameterizing, adjusting and analyzing software

Instruction manual Volume 1

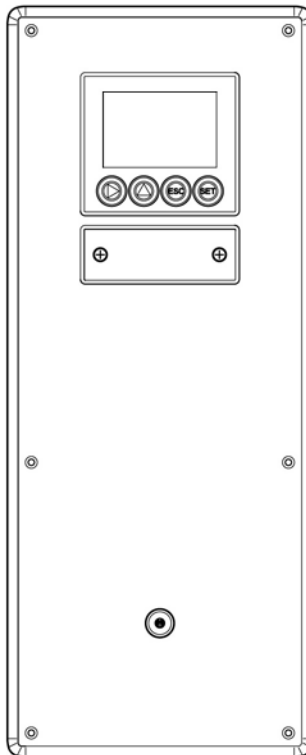

---

# 1 Safety and the environment

## **Avoiding electrical hazards**

- > Never use the instrument and connected probes to measure on or near live parts!
- > Damaged mains cables must only be replaced by authorized personnel.
- > Only have the transmitter wired and connected by authorized personnel with the voltage disconnected.
- > You must always comply with the regulations applicable in your country for opening and repairing electrical equipment.

## **Avoiding personal injury and damage to equipment**

- > Installation, setting and calibration work must only be carried out by qualified and authorized personnel!
- > Only open the instrument when this is expressly described in the instruction manual for installation, maintenance or repair purposes.
- > Observe the permissible storage, transport and operating temperature.
- > Do not store the product together with solvents. Do not use any desiccants.
- > Do not use the instrument for control purposes at the same time as operating or servicing the transmitter.
- > Only operate the product properly, for its intended purpose and within the parameters specified in the technical data. Do not use any force.
- > Carry out only the maintenance and repair work on this instrument that is described in the documentation. Follow the prescribed steps exactly. Use only original spare parts from Testo.

Any additional work must only be carried out by authorized personnel. Otherwise testo will not accept any responsibility for the proper functioning of the instrument after repair and for the validity of certifications.



**Protecting the environment**

- > At the end of its useful life, send the product to the separate collection for electric and electronic devices (observe local regulations) or return the product to Testo for disposal.

## 2 About this document

**Use**

- > Please read this documentation through carefully and familiarize yourself with the product before putting it to use. Pay particular attention to the safety instructions and warning advice in order to prevent injuries and damage to the products.
- > Keep this document to hand so that you can refer to it when necessary.
- > Hand this documentation on to any subsequent users of the product.

 <b>WARNING</b>	Indicates potential serious injuries
 <b>CAUTION</b>	indicates potential minor injuries

**Symbols and writing standards**

Representa- tion	Explanation
<b>i</b>	Note: Basic or further information.
1. ...	Action: more steps, the sequence must be followed.
2. ...	
> ...	Action: a step or an optional step.
- ...	Result of an action.
<b>Menu</b>	Elements of the program interface.
<b>[OK]</b>	Buttons of the program interface.
...   ...	Functions/paths within a menu.
“...”	Example entries

<b>3</b>	<b>Contents</b>	
<b>1</b>	<b>Safety and the environment</b>	<b>3</b>
<b>2</b>	<b>About this document</b>	<b>4</b>
<b>3</b>	<b>Contents</b>	<b>5</b>
<b>4</b>	<b>Transmitter</b>	<b>7</b>
4.1.	Specifications	7
4.1.1.	Functions and use	7
4.1.2.	Scope of delivery	7
4.1.3.	Accessories	7
4.1.4.	Technical data	8
4.1.5.	Dimensions	12
4.2.	Product description	13
4.2.1.	At a glance	13
4.2.2.	Usable probes	14
4.2.3.	Display and keypad	15
4.2.4.	Service interface	15
4.2.5.	Relay board (option)	15
4.2.6.	Analog outputs	16
4.2.7.	Parameters	16
4.2.8.	Scaling	17
4.2.9.	Alarm handling	19
4.3.	Commissioning	20
4.3.1.	Mounting preparations	20
4.3.2.	Connecting the instrument	21
4.3.2.1.	Overview of terminals	22
4.3.2.2.	Connecting voltage supply and analog outputs	23
4.3.2.3.	Connecting the relay outputs	24
4.3.2.4.	Closing the instrument	27
4.3.3.	Ethernet communication	29
4.3.3.1.	Types of operation	29
4.3.3.2.	Mains connection	29
4.3.3.3.	Setting the IP address	29
4.3.3.4.	Integration into customer's Ethernet system	29
4.3.3.5.	Adjusting the instrument	39
4.3.3.6.	Overview: Adjustment keys and test contacts	40
4.3.3.7.	1-point adjustment (offset - humidity/temperature)	41
4.3.3.8.	Analog output adjustment	43
4.3.3.9.	n-point adjustment (pressure)	44
4.3.3.10.	High-humidity adjustment for testo 6614	45
4.3.3.11.	Self adjustment of testo 6615 trace humidity probe	46
4.4.	Operation	47
4.4.1.	Relationship between user menu and mini-DIN socket is active	47

4.4.2.	Password protection .....	47
4.4.3.	Structure of user menu .....	47
4.4.4.	Overview of the testo 6383 user menu .....	49
4.4.5.	The individual main menus .....	52
4.4.5.1.	Editing main menu of channel 1 .....	52
4.4.5.2.	Editing Main Menu Channel 2 (if this option is available) .....	52
4.4.5.3.	Editing Main Menu Channel 3 (if this option is available) .....	53
4.4.5.4.	Editing Main Menu Alarm .....	53
4.4.5.5.	Editing Main Menu Settings .....	55
4.4.5.6.	Editing Main Menu Analysis .....	58
4.4.5.7.	Editing Message main menu .....	60
4.4.5.8.	Calling up Main Menu Ident .....	61
4.4.5.9.	Editing Main Menu Adjust .....	61
4.4.5.10.	Editing Reset main menu .....	63
4.5.	Status, warning and error messages .....	64
4.5.1.	Status messages .....	65
4.5.2.	Warning messages .....	66
4.5.3.	Transmitter error messages .....	67
4.5.4.	Handling alarm messages .....	69
4.5.5.	Namur fault conditions .....	71
4.6.	Maintenance and cleaning .....	72
4.6.1.	Maintaining the instrument .....	72
4.6.2.	Cleaning the instrument .....	72

## **4 Transmitter**

### **4.1. Specifications**

#### **4.1.1. Functions and use**

The testo 6383 transmitter is suitable for the following applications with Ethernet networking, amongst others:

- Clean rooms
- Complex room climate applications

In addition to the signal transmission of the readings to a control unit via analog outputs, the measurement data can simultaneously be recorded, documented and visualized via Ethernet.

Furthermore, it is possible to issue an alarm for those responsible for the process, if necessary.

#### **4.1.2. Scope of delivery**

The scope of delivery of the testo 6383 transmitter includes the following:

- With KMAT version D04: Integrated humidity probe
- Sealing frame
- Instruction manual
- Calibration report
- CD-ROM with operating instructions (PDF), configuration files for Ethernet module and P2A update (this can only be used in conjunction with the P2A software, which has to be ordered separately).

#### **4.1.3. Accessories**

The following accessories are available for the testo 6383 transmitter, amongst others:

- Protection caps for probes
- Mains unit
- P2A software (parameterizing, adjusting and analyzing software)
- Assembly accessories

---

**i** Information about accessories and their order numbers can be found in volume 2, **Accessories and spare parts** or on the website at [www.testo.com](http://www.testo.com).

---

## 4.1.4. Technical data

### Parameters

- Differential pressure
- Temperature
- Humidity

### Differential pressure accuracy

---

**i** The specifications are only valid if the positive pressure is applied at the positive pressure connection.

---

- 0.3 % of measuring range, additional 0.3 Pa intrinsic error<sup>1</sup>
- $T_{K \text{ slope drift}} = 0.02 \%$  of measuring range per degree Kelvin of deviation from nominal temperature 22 °C
- $T_{K \text{ zero point drift}} = 0 \%$ , as zeroing with solenoid valve<sup>2</sup>

### Humidity and temperature accuracy

- Depends on probe

### Humidity and temperature measuring range

- Depends on probe

---

<sup>1</sup> Measuring uncertainty in accordance with GUM:  $\pm 0.5 \%$  of measuring range final value  $\pm 0.3 \text{ Pa}$ .

GUM (Guide to the Expression of Uncertainty in Measurement): ISO guideline for determining the measuring uncertainty in order to render global measurement results comparable.

The following uncertainties are used during the inquiry:

- Hysteresis
- Linearity
- Reproducibility
- Adjustment area/factory calibration
- Test location

<sup>2</sup> Minor mixtures of the media may occur at the positive and negative pressure side due to the automatic zeroing cycle.



### Pressure measuring range, resolution and overload of differential pressure

Pressure measuring range depending on version ordered	Resolution	Overload
0 to 50 Pa	0.1 Pa	20,000 Pa
0 to 50 Pa	0.1 Pa	20,000 Pa
0 to 100 Pa	0.1 Pa	20,000 Pa
0 to 500 Pa	0.1 Pa	20,000 Pa
0 to 10 hPa	0.01 hPa	200 hPa
-10 to 10 Pa	0.1 Pa	20,000 Pa
-50 to 50 Pa	0.1 Pa	20,000 Pa
-100 to 100 Pa	0.1 Pa	20,000 Pa
-500 to 500 Pa	0.1 Pa	20,000 Pa
-10 to 10 hPa	0.01 hPa	200 hPa



Upon delivery and following a factory reset the readings are shown in the display in the unit that was ordered via the KMAT option Fxx, see Ordering options for testo 6383 transmitter (0555 6383), page 146.

### Humidity and temperature resolution

- 0.1 % RH or 0.01 °C/0.01 °F

### Meas. cycle

- 1/sec

### Interface

- Mini-DIN for P2A software (parameterizing and adjusting software) and handheld testo 400/650
- Ethernet interface RJ45 (Ethernet 10 BatesT/100)

### Voltage supply

- 4-wire (separate signal and supply lines): 20 to 30 V AC/DC, 300 mA power consumption

### Maximum load

- 4-wire: 500 Ω (power output)

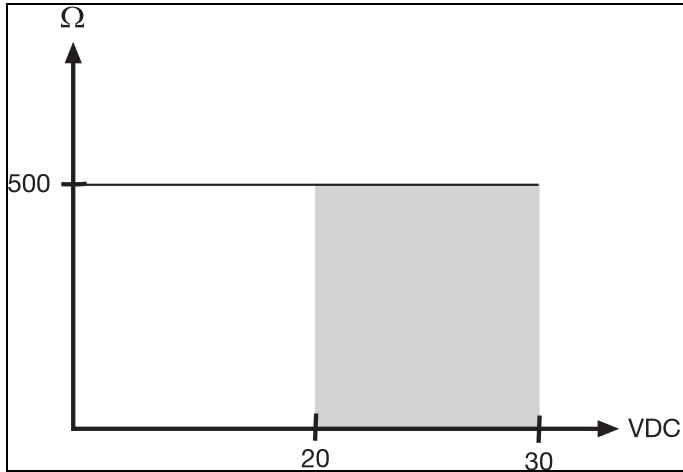

**Maximal load**

- 4-wire: 10 k $\Omega$  (voltage output)

**Analog output**

- 0 to 1 V  $\pm$  1.5 mV (4-wire) or
- 0 to 5 V  $\pm$  7.5 mV (4-wire) or
- 0 to 10 V  $\pm$  15 mV (4-wire) or
- 0 to 20 mA  $\pm$  0.03 mA (4-wire) or
- 4 to 20 mA  $\pm$  0.03 mA (4-wire)

**Resolution of analog output**

- 12 bit

**Relay**

- 4 relays, 250 V AC/DC, 3 A (optional)

**Display**

- 2-line LCD with plain text line (optional)

**Operating temperature**

- -5 to 50  $^{\circ}$ C/23 to 122  $^{\circ}$ F

**Storage temperature**

- -20 to 60 °C/-4 to +140 °F

**Oper. humidity**

- 0 to 90 % RH

**Housing, weight**

- Metal/plastic
- Version with integrated humidity probe: approx. 1.35 kg
- Version with preparation for external humidity probe: approx. 1.26 kg

**Protection class, frontal**

- IP 65 only if the transmitter is wired, Ethernet connector is inserted and/or sealing plugs are inserted

**Directives, standards and tests**

- EC Directive: 2004/108/EC
- DIN 14644-4
- EN 61000-6-2 interference immunity
- EN 61000-6-3 interference emission
- EN 61326-1+A1+A2

**Warranty**

- Duration: 2 years
- Warranty conditions: see website [www.testo.com/warranty](http://www.testo.com/warranty)

### 4.1.5. Dimensions

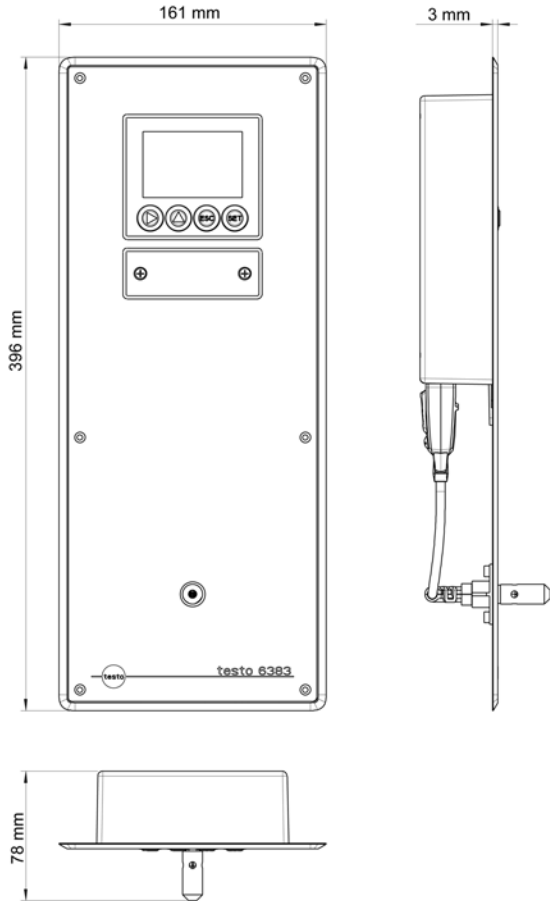

## 4.2. Product description

### 4.2.1. At a glance

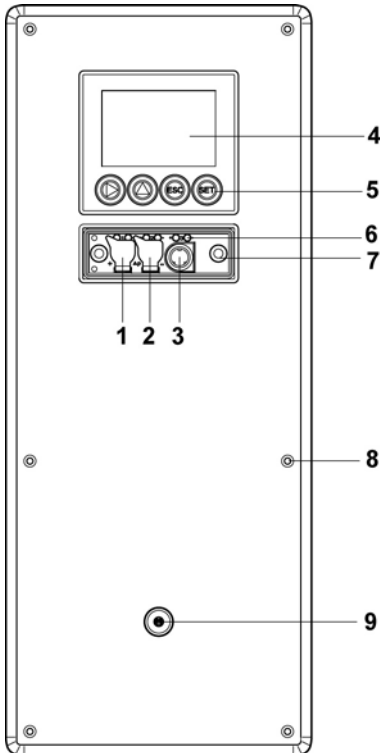

- 1 Sealing plugs on the positive pressure test connection ( $\varnothing$  4 mm)
- 2 Sealing plugs on the negative pressure test connection ( $\varnothing$  4 mm)
- 3 Socket for service plug
- 4 Display (optional)
- 5 Keys (only with optional display)
- 6 Test rods for the analog outputs
- 7 Service cover screw connection (self-locking, 2 pcs.)
- 8 Openings for screws for fastening to the wall
- 9 Only with integrated humidity probe (KMAT option D04): Opening for the integrated humidity probe

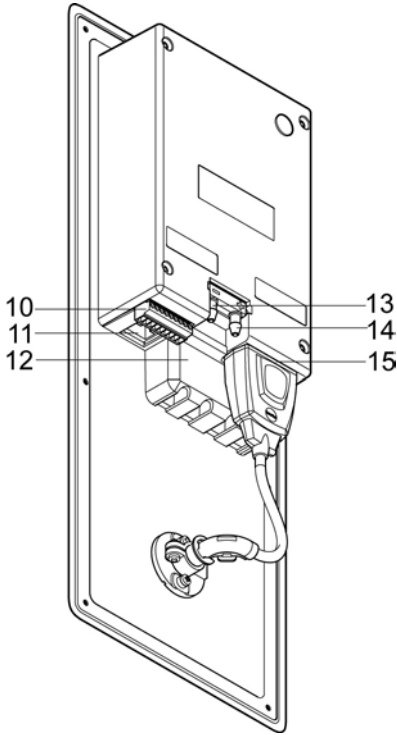

- 10 9-pin connector for the current/voltage supply
- 11 Socket for Ethernet interface
- 12 Relay cover with 12-pin connector underneath for relay connection (option)
- 13 Negative pressure connection (Ø 6,4 mm )
- 14 Positive pressure connection (Ø 6,4 mm )
- 15 Probe socket

### 4.2.2. Usable probes

The testo 6383 transmitter can be used with the following probes:

Probes	Article no.	Characteristic
Integrated humidity probe	KMAT option D04 (0636 6610)	<b>Wall</b> probe version; accuracy to ±1 % RH; temperature range -20 to +70 °C/-4 to +158 °F, plug-on sensor
testo 6613	0555 6610-L13	<b>Cable</b> probe version; accuracy to ±1 % RH; temperature range -40 to +180 °C/ -40 to +356 °F, sensor soldered
testo 6614	0555 6610-L14	<b>Heated cable</b> probe version; accuracy to ±1.0 % RH; temperature range -40 to +180 °C/ -40 to +356 °F, sensor soldered
testo 6615	0555 6610-L15	<b>Trace humidity cable</b> probe version; accuracy ±1 K at 0 °Ctd/+32 °Ftd; temperature range -40 to 120 °C/-40 to +248 °F, sensor soldered

Probes	Article no.	Characteristic
testo 6617	0555 6610-L17	<b>Cable with cover electrode monitoring</b> probe version; accuracy to $\pm 1.2\%$ RH; temperature range -40 to 180 °C/ -40 to +356 °F, sensor soldered

### 4.2.3. Display and keypad

The display option allows operation of the testo 6383 transmitter via the display and four keys.

The LCD display consists of two 7-segment lines for displaying readings and units and of an information line (for status messages, for example).

The brightness and contrast of the display and the background lighting (permanent or off) can be changed via the user menu or the P2A software.

### 4.2.4. Service interface

The parameterizing socket (mini-DIN) is located behind the service flap as an interface to the P2A software or Testo handheld instrument (testo 400/testo 650).

### 4.2.5. Relay board (option)

This has a floating switch capacity of 250 V AC/3 A. The switching limits and hysteresis as well as the function as relay for the collective alarm can be set via the display or the P2A software.

Further features include:

- Function of changeover contacts (NC/NO contacts) freely selectable
- 12 terminals for a total of 4 relays.



If no relays are available, settings for monitoring limit values or alarms can still be controlled via the display. The alarm status will be shown on the display.



Only have the transmitter wired and connected by authorized personnel with the voltage disconnected.

---

### 4.2.6. Analog outputs

As analog outputs, the testo 6383 has either

- 1 or optionally 3 current outputs of 0 to 20 mA (4-wire)/4 to 20 mA (4-wire) or
- 1 or optionally 3 voltage outputs of 0 to 1 V/0 to 5 V/0 to 10 V (4-wire).

The transmitter can be ordered with three analog outputs as an option.

The optional three channels are galvanically isolated.

### 4.2.7. Parameters

The following parameters are displayed

- Differential pressure in Pa, hPa, kPa, mbar, bar, mmH<sub>2</sub>O, inch H<sub>2</sub>O, inch HG, kg/cm<sup>2</sup>, PSI
- Relative humidity in % RH (technical)
- Relative humidity in % WMO\* (calculation according to the WMO standard)
- Degree of humidity in g/kg and gr/lb
- Absolute humidity in g/m<sup>3</sup> and gr/ft<sup>3</sup>
- Water content in ppm (vol) and % vol
- Psychrometer temperature in °C<sub>tw</sub> and °F<sub>tw</sub>
- Enthalpy in kJ/kg and BTU/lb
- Water vapour partial pressure in hPa and inch H<sub>2</sub>O
- Dewpoint temperature in °C<sub>td</sub> and °F<sub>td</sub>
- Standardized dewpoint in °C<sub>tdA</sub>, standardized at atmospheric pressure (1013 hPa); precondition: Absolute process pressure.
- Dewpoint of H<sub>2</sub>O<sub>2</sub> mixture in °C<sub>tm</sub> and °F<sub>tm</sub>.

\* It is possible that condensation appears as of a displayed humidity starting from 70 % and is shown on the display. This unit is used in meteorology, amongst others. When calculating the relative humidity the Magnus coefficient with undercooled water is used in accordance with WMO.



Calculated humidity variables correspond to the medium of air. With other gases/gas compositions, deviations may occur, e.g. with the enthalpy.

---

- Temperature °C and °F



## 4.2.8. Scaling

There are three types of min./max. values:

- 1 The measuring range: The maximum sensor performance is in this range. Values outside of the measuring range are displayed via messages, for example. Measuring range, see table (below).
- 2 Standard scaling: The output signals are assigned to this measuring range as standard:
  - during delivery if no entries are made in the order code
  - after exchanging the unit, the measuring range recorded in the instrument is applied as standard.



The transmitter even retains its scaling with the voltage disconnected.

---

Measuring range, see table (below).

- 3 The maximum settings for the manual scaling
  - The maximum limits can be calculated as follows:  
 $X = \text{difference between MIN. and MAX. value of the standard scaling}$   
 $(\text{Max. value of standard}) + (50 \% \text{ of } X)$   
 $(\text{Min. value of standard}) - (50 \% \text{ of } X)$
  - It is thus possible to scale beyond the measuring range, e.g. for the adjustment of the scaling limits to standard values of a PLC.

With the alarm definition, however, the physical measuring range limits are decisive.

Measuring range/standard scaling	Maximum scaling
0 to 50 Pa	-5 to 15 Pa
0 to 50 Pa	-25 to 75 Pa
0 to 100 Pa	-50 to 150 Pa
0 to 500 Pa	-250 to 750 Pa
0 to 10 hPa	-5 to 15 hPa
-10 to 10 Pa	-20 to 20 Pa
-50 to 50 Pa	-100 to 100 Pa
-100 to 100 Pa	-200 to 200 Pa

-500 to 500 Pa	-1000 to 1000
-10 to 10 hPa	-20 to 20 hPa

Parameter	Unit	Probes	Physical measuring range at 1013 hPa		Standard scaling of transmitter measuring range	
			MIN	MAX	MIN	MAX
Temperature	°C	6611	-20	+70	-20	+70
	°F	6611	-4	+158	-4	+158
	°C	6613, 6614, 6617	-40	+180	-40	+180
	°F	6613, 6614, 6617	-40	+356	-40	+356
	°C	6615	-40	+120	-40	+120
	°F	6615	-40	+248	-40	+248
Dewpoint	°C <sub>td</sub>	6611	-20	+70	-80	+100
	°F <sub>td</sub>	6611	-4	+158	-112	+212
	°C <sub>td</sub>	6613, 6614, 6617	-20	+100	-80	+100
	°F <sub>td</sub>	6613, 6614, 6617	-4	+212	-112	+212
	°C <sub>td</sub>	6615	-60	+30	-80	+100
	°F <sub>td</sub>	6615	-76	+86	-112	+212
Absolute humidity	g/m <sup>3</sup>	all probes	0	600	0	2000
	gr/ft <sup>3</sup>	all probes	0	250	0	800
relative humidity	% RH	all probes	0	100	0	100
WMO relative humidity	% RH		0	100	0	100
Mixture dewpoint (H <sub>2</sub> O <sub>2</sub> )	°C <sub>tm</sub>		-20	+100	-20	+100
	°F <sub>tm</sub>		-4	+212	-4	+212

			Physical measuring range at 1013 hPa		Standard scaling of transmitter measuring range	
Degree of humidity	g/kg	all probes	0	13300	0	9500
	gr/lb	all probes	0	93000	0	66500
Enthalpy	kJ/kg		-40	99999	-40	8000
	BTU/lb		-18	43000	-18	3500
Psychrometer temperature	°C <sub>tw</sub>		-40	100	-40	180
	°F <sub>tw</sub>		-58	210	-40	356
Water content	ppm (vol) H <sub>2</sub> O		0	99999	0	99999
	% vol		0	100	0	100
Water vapour partial pressure	hPa		0	1000	0	7000
	inchH <sub>2</sub> O		0	400	0	2800

#### 4.2.9. Alarm handling

For upper and lower alarm limits, individual alarms as well as collective alarms can be specified. If the collective alarm function is activated, an alarm is triggered as soon as the alarm limit of an alarm is exceeded, if this alarm is assigned to the collective alarm.

The testo 6383 monitors limit values with the help of relays. If a reading is outside the limit values, a relay to be specified by the user is switched.

If the reading reverts to more than a specified hysteresis below or above the limit value, the alarm is cancelled.

In addition, information about the occurrence of error/status messages can be provided by means of a collective alarm relay, see Status, warning and error messages, page 64



If multiple alarm messages are activated at the same time, the last alarm is shown. If the alarm is cancelled again, the previous messages are no longer shown.

---

### 4.3. Commissioning

#### 4.3.1. Mounting preparations

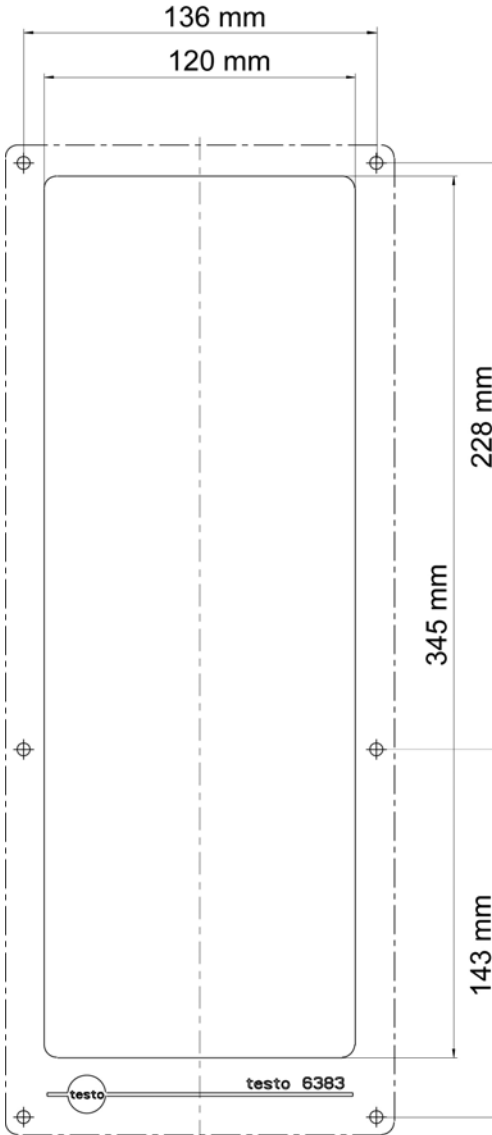

1. Create a wall opening (approx. 120 mm x 220 mm) at the mounting location.
2. Hold 6383 in assembly position and mark the drill holes.
3. Drill holes suitable for the screws to be used.
4. Connect 6383.

### 4.3.2. Connecting the instrument

 **WARNING**

**Electrical voltage**

**Danger of injury!**

- > De-energize the mains connection before connecting the transmitter.



Only have the transmitter wired and connected by authorized personnel with the voltage disconnected.

---

### 4.3.2.1. Overview of terminals

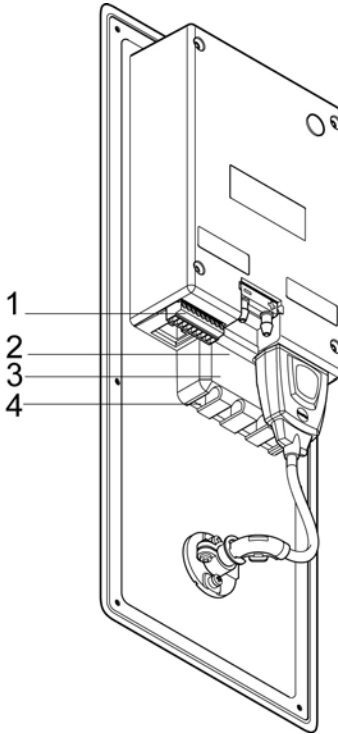

- |  |   |
|--|---|
| 1 Terminal strip for voltage supply and analog outputs | 3 Relay cover (option)  |
| 2 Relay terminal strip (option), below the relay cover | 4 Insulating trough for relay board (option), below the relay cover |

---

**i** The following description of the terminals refer to this overview and its numbering.

---

### 4.3.2.2. Connecting voltage supply and analog outputs

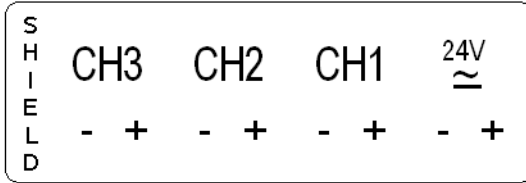

Terminal strip for voltage supply and analog outputs, item (1) of overview of terminals

#### Wiring diagram for 4-wire system (0 to 20 mA/4 to 20 mA/0 to 1 V/0 to 5 V/0 to 10 V)

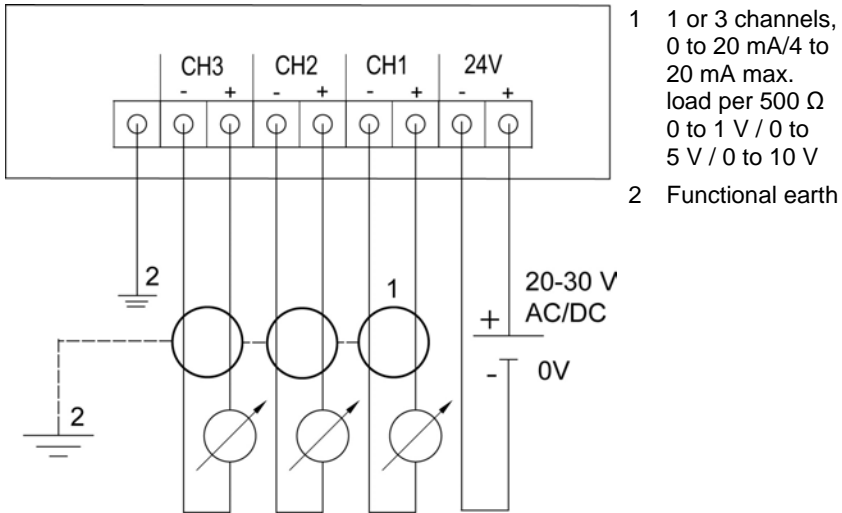

Requirement for the connecting cable of the supply:

- Shielded and insulated with cross-section of at least 0.25 sq. mm, maximum 1.5 sq. mm without wire end sleeves.
- The supply line must be secured against exceeding 0.5 A.
- An OFF switch must be installed in an easily accessible position close by and be marked as such.

1. Disconnect terminal strip for voltage supply and analog outputs.
2. Strip the cable ends, clamp wire end ferrules on and screw down with voltage terminals/channel terminals.
3. Tie together each of the two adjacent cores using a cable tie.

- Attach terminal strip for voltage supply and analog outputs.

### 4.3.2.3. Connecting the relay outputs

**i** Only have the transmitter wired and connected by authorized personnel with the voltage disconnected.

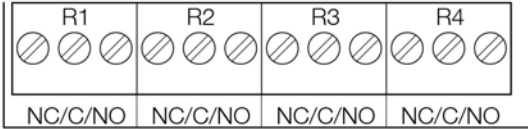

Relay terminal strip, item (2) of overview of terminals

There is the option of twelve terminals for a total of four relays.

- Remove relay cover.
- Disconnect relay terminal strip.
- Strip cable ends and clamp on wire end ferrules.
- Connect relays according to chosen function (NC/NO) (see diagrams below; relay 1 is shown as an example of a connection).

#### Connection note

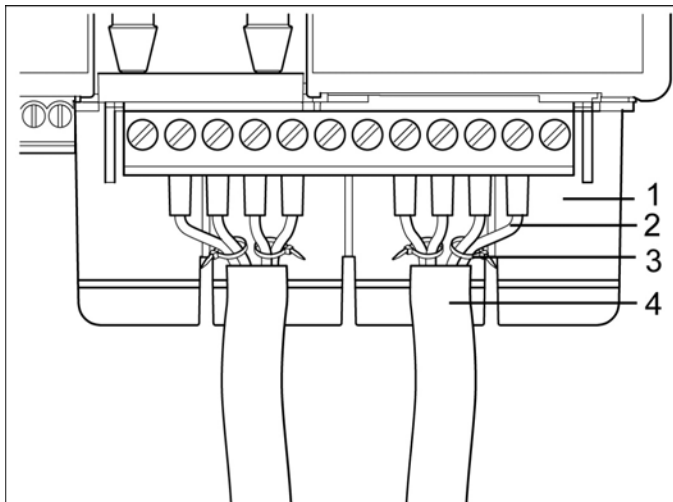

- i**
- For the connection, a double-insulated mains cable (sheathed cable) with a cross-section of at least 1.5 mm<sup>2</sup> must be used.
  - Cable connection (2) may not be routed in a loop within the relay trough (1).



- It is recommended that you always tie 2 adjacent cores to one another using a cable tie (3).
- The insulation of the cable must be fed at least 5 mm (4) into the relay tray up to the elevated part.

### Use of relay as NC contact (NC = normally closed)

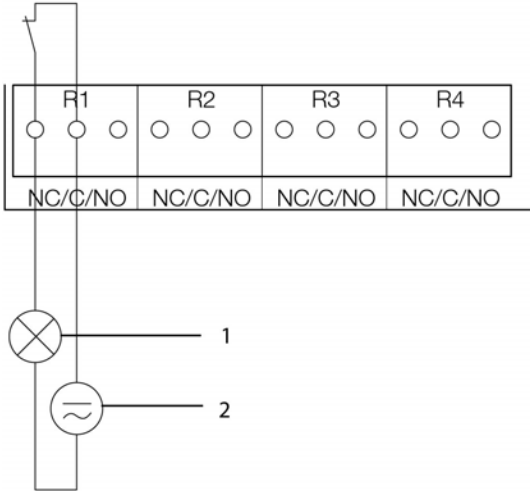

- 1 Alarm/status light  
(example of installation)
- 2 250 V AC/DC, 3 A

**i** The busy light (alarm/status light) is permanently on until the relay opens or the circuit is interrupted. This circuit can therefore be used to monitor the functionality of the alarm circuit, as a cable break, for instance, is indicated by the busy light going off.

**Use of relay as NO contact (NO = normally open)**

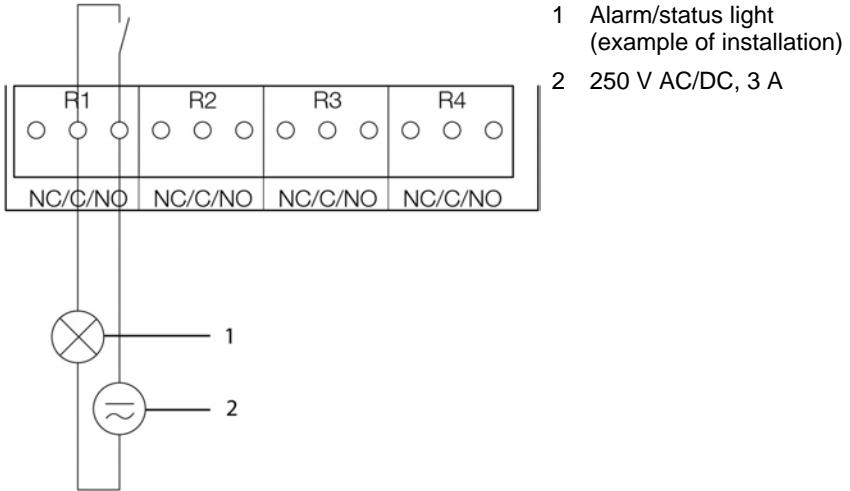

---

**i** The busy light (alarm/status light) only comes on when the relay is switched (closed). Monitoring the functionality of the alarm circuit is therefore not possible with this switching operation.

---

5. Insert relay terminal strip into socket.
6. Set on relay cover.

#### 4.3.2.4. Closing the instrument

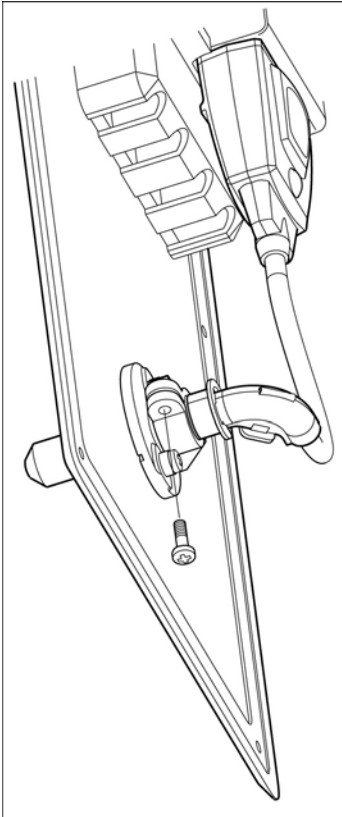

1. Connect probe.
  - Version with integrated humidity probe:
    1. Insert probe into probe socket.
    2. Guide probe through opening of front plate.
    3. Tighten screw at opening.
  - Version with external humidity probe:
    - > Insert probe into probe socket.
4. Slide Ethernet connector into Ethernet socket.

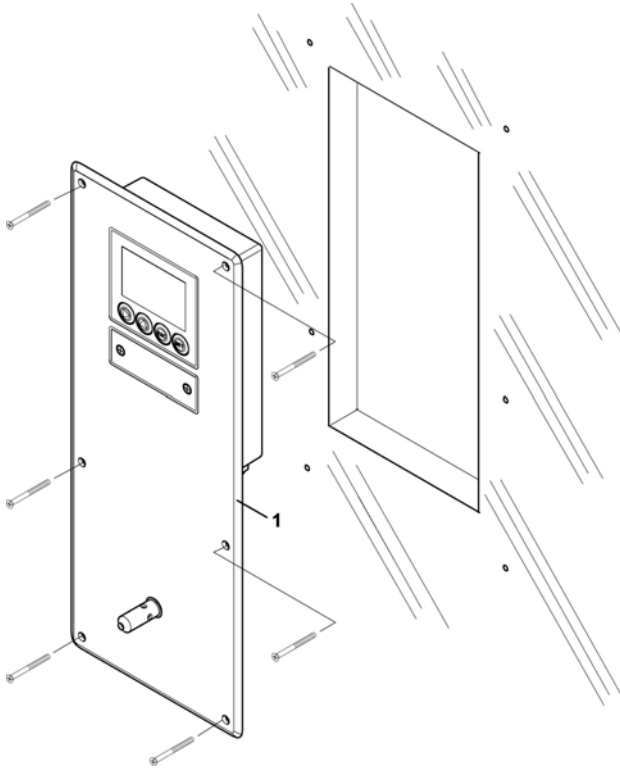

5. Pull sealing frame (1) over the edge of the 6383.
6. Screw on 6383. Initially, only tighten the screws slightly. When all screws are in position, also align 6383 and tighten the screws.
7. Seal 6383 using a measure appropriate for the installation point (e.g. with a silicone strip).

### 4.3.3. Ethernet communication

#### 4.3.3.1. Types of operation

A corresponding testo 6383 can be integrated into any Ethernet systems

#### 4.3.3.2. Mains connection

> Connect the network cable to the transmitter.



The network cable must not be connected directly to the telephone network (ISDN).

---

#### 4.3.3.3. Setting the IP address

- ✓ Network cable must be connected to the Ethernet interface.
- ✓ Service plug must be inserted.

The IP address of the transmitter will be set via the P2A software (transmitter accessories).

1. Set IP address with the P2A software (see Using the software, page 116).
2. Disconnect service plug.

#### 4.3.3.4. Integration into customer's Ethernet system

##### Precondition

---



The user should be familiar with the structure of an XML document. Furthermore, enough knowledge should be available that this type of document can be downloaded and decoded via an Internet connection with the aid of a programming/script language.

---

##### Interface

The communication takes place according to the client/server principle, whereby the Ethernet module takes on the role of the server:

The XML interface will be approached via a URL. The URL consists of the IP address of the Ethernet module, the path for the XML document and, depending on the URL, with a clearly defined parameter. If a parameter is missing or an incorrect value is

transferred, the Ethernet module sends back a simple error message.

Example:

IP address = 254.169.100.100

URL for serialnumber.xml:

http://254.169.100.100/data/getserialnumber

If a parameter is required, a "?" is always in the first place after the URL, then the parameter is transferred to the common query string form (name=value).

Example:

IP address = 254.169.100.100

URL for / identification.xml:

http://254.169.100.100/data/getidentification?param=0 (compare table xml codes)

After calling up the compound URL, if everything was correct, an XML document is returned. With faulty parameters a simple HTML answer comes that points out the reason that an XML answer could not be given.

If an XML document is to be loaded on the server, access is provided by means of a POST request

Example of an upload via the program wget:

IP address = 254.169.100.100

URL for / usersettings.xml:

Path details of the folder in which the wget program is located	Command	Path details of the folder in which the usersettings XML file is located	IP address of the transmitter and required URL (see table on the next page)
H:/wget/wget-complete-stable	/wget --post-file=	C:/usersettings.xml	254.169.100.100/config/setusersettings

The Ethernet module supports reading out of

- Readings
- Instrument type (testo 6383)
- Firmware date and version (testo 6383)
- Status and status messages (testo 6383)
- Alarm messages (testo 6383)
- Service hour counter (testo 6383 and probe)

as well as the reading and writing of the:

- Adjustment data (testo 6383)

- Configuration data of analog outputs (testo 6383)
- Configuration data of relays (testo 6383)
- User settings (testo 6383)

### XML codes (download)

The table of XML codes is available for download at [www.testo.de/transmitter](http://www.testo.de/transmitter) as well as on the product CD

URL	Description	Parameter	Answer (see Appendix)
/data/getserialnumber	Read off serial number of connected transmitter		serialnumber.xml
/data/getidentification	Read off type of connected transmitter/probe	param=0 (for transmitter) param=1 (for probe)	identification.xml
/data/getversion	Read off firmware version of connected transmitter		version.xml
/data/getfirmwaredate	Read off firmware date of connected transmitter		firmwaredate.xml
/data/getonlinevalue	Read off online values of connected transmitter		onlinevalue.xml
/data/getviewchannels	Read off view channels of connected transmitter		viewchannels.xml
/data/getstatus	Read off status of connected transmitter		status.xml
/data/getlaststatusmessage	Read off last status message of connected transmitter		laststatusmessage.xml
/config/gethourscount	Read off service hour counter of transmitter or probe		hourscount.xml
/config/getusersettings	Read off settings of transmitter		usersettings.xml
/config/getcalibration	Read off adjustment data of transmitter	param=0 (adjustment set 1) param=1 (adjustment set 2) param=2 (adjustment set 3)	calibration.xml
/config/getredefinition	Read off relay information of transmitter	param=0 (relay 1) param=1 (relay 2) param=2 (relay 3) param=3 (relay 4)	redefinition.xml
/config/getheatertime	Read off sensor heating information		heatertime.xml

URL	Description	Parameter	Answer (see Appendix)
/config/getoptions	Read off options of transmitter		options.xml
/config/getcollectivealarm	Read off alarm messages of transmitter		collectivealarm.xml

### Upload XML documents

URL	Description	Parameter	Post	Answer (see Appendix)
/config/setusersettings	Perform settings of transmitter		usersettings.xml	usersettings.xml
/config/setcalibration	Set adjustment data of transmitter	param=0 (adjustment set 1) param=1 (adjustment set 2) param=2 (adjustment set 3)	calibration.xml	calibration.xml
/config/setredefinition	Set relay information of transmitter	param=0 (relay 1) param=1 (relay 2) param=2 (relay 3) param=3 (relay 4)	redefinition.xml	redefinition.xml
/config/setheatertime	Set sensor heating information		heatertime.xml	heatertime.xml
/config/setoptions	Set options of transmitter		options.xml	options.xml
/action/setresetm	Not yet implemented		resetm.xml	

### Description of the XML elements

#### General elements

XML tag	Description	Type
measurement_value	Parent element. Contains the child elements value, unit, resolution	
value	Reading	Numerical, decimal number
unit	Unit	ASCII
number_values	Qty.	Numerical, whole number



## Elements in calibration.xml

XML tag	Description	Type
calibration_data	Base element. Contains the child elements unit, attenuation, cal_reserved, cal_offset, cal_scale.	
unit	See general elements	
attenuation	Damping (0 - 15)	Numerical, decimal number
cal_offset	Offset	Numerical, whole number
cal_scale	Parent element. Contains the child elements cal_minscale, cal_maxscale	
cal_minscale	Scaling value	Numerical, decimal number
cal_maxscale	Scaling value	Numerical, decimal number

## Elements in collectivealarm.xml

XML tag	Description	Type
colalarmtable	Base element. Contains the child elements alarm_numbers, alarm	
alarm_numbers	Number of alarm messages	Numerical, whole number
alarm	Parent element. Contains the child elements alarm_event, alarm_state	
alarm_event	Type of alarm	ASCII
alarm_state	Status of the alarm 0 = alarm inactive 1 = alarm active	Numerical, whole number

## Elements in firmwaredate.xml

XML tag	Description	Type
firmware_date	Base element. Contains the child elements year, month, day	
year	Year	Numerical, whole number
month	Month	Numerical, whole number
day	Day	Numerical, whole number

## Elements in heatertime.xml

XML tag	Description	Type
heatertime	Base element. Contains the child element heatertimeoff	
heatertimeoff	Time sensor heating off in min	Numerical, whole number

## Elements in hourscount.xml

XML tag	Description	Type
hourcount	Base element. Contains the child element hours	
hours	Service hour counter in h	Numerical, whole number

## Elements in identification.xml

XML tag	Description	Type
ident	Base element. Contains the child element device_id	
device_id	Transmitter type	Numerical, whole number

## Elements in laststatusmessage.xml

XML tag	Description	Type
mufmsg	Base element. Contains the child elements msg, sn, hours	
msg	Status message	ASCII
sn	Serial number	ASCII, 8 characters
hours	Service hour counter in h	Numerical, whole number

## Elements in onlinevalue.xml

XML tag	Description	Type
online_values	Base element. Contains the child elements number_values, measurement_value	
number_values	See general elements	
measurement_value	See general elements	

## Elements in options.xml

XML tag	Description	Type
options	Base element. Contains the child elements device_options, production_options	
device_options	See device_options description	Numerical, whole number
production_options	See production_options description	Numerical, whole number

## Elements in redefinition.xml

<b>XML tag</b>	<b>Description</b>	<b>Type</b>
relay_data	Base element. Contains the child elements relay_channel, relay_number, relay_status, sw_point_character, sw_point_value, hysteresis_value	
relay_channel	Measurement channel linked to the relay	Numerical, whole number
relay_number	Relay number (0 - 2)	Numerical, whole number
relay_status	Status of relay 0 = off 1 = on	Numerical, whole number
sw_point_charact	Switch point: Switch point: 0 = low-limit monitoring 1 = high-limit monitoring	Numerical, whole number
sw_point_value	Switch point	Numerical, decimal number
hysteresis_value	Hysteresis	Numerical, decimal number

## Elements in serialnumber.xml

<b>XML tag</b>	<b>Description</b>	<b>Type</b>
serialnumber	Base element. Contains the child element number	
number	Serial number	ASCII, 8 characters

## Elements in status.xml

<b>XML tag</b>	<b>Description</b>	<b>Type</b>
mufstatus	Base element. Contains the child elements statemsg, staterel, statecounter	
statemsg	Status message See statemsg description	Numerical, whole number
staterel	Status relay See staterel description	Numerical, whole number
statecounter	Counter	Numerical, whole number

## Elements in usersettings.xml

XML tag	Description	Type
usersettings	Base element. Contains the child elements (pressure)* , (abs_pressure_pa_process)*, (humidity_process)*, (temperature_c_process)*, (humidity_norm)*, (abs_pressure_pa)*, h2o2, setting_display, backlight, contrast, language, disp_msg, h2o2_prozess	
pressure	Absolute pressure	Numerical, decimal number
h2o2	H2O2 value	Numerical, decimal number
setting_display	Auto OFF background lighting 0 -> background lighting auto off 1 -> background lighting stays on	Numerical, whole number
backlight	Brightness of background lighting 0 to 9 (0 = off, 9 = max.)	Numerical, whole number
contrast	Display contrast 0 to 9 (0 = min., 9 = max.)	Numerical, whole number
language	Language 0 ->GERMAN 1 ->ENGLISH 2 ->FRENCH 3 ->SPANISH 4 ->ITALIAN 5 ->JAPANESE 6 ->SWEDISH	Numerical, whole number
disp_msg	Status messages display 0 = off 1 = on	Numerical, whole number
h2o2_prozess	H2O2 process 0 = via H2O2 water 1 = process with evaporated H2O2	Numerical, whole number
abs_pressure_pa_process,	Pressure process data, absolute pressure in Pa	Numerical, decimal number
humidity_process	Pressure process data, process humidity in % RH	Numerical, decimal number
temperature_c_process	Pressure process data, process temperature in °C	Numerical, decimal number
abs_pressure_pa	Humidity process data, absolute pressure in Pa	Numerical, decimal number

---

\* Child elements are optional

## Elements in versions.xml

XML tag	Description	Type
firmware_version	Base element. Contains the child element version	
version	Firmware version:	ASCII, 6 characters

## Elements in viewchannels.xml

XML tag	Description	Type
view_channels	Base element. Contains the child elements number_values, view_channel	
number_values	See general elements	
view_channel	Parent element. Contains the child elements channel_info, measurement_value, meas_status	
channel_info	Parent element. Contains the child elements connector_info, channel_type	
measurement_value	See general elements	
meas_status	Parent element. Contains the child elements min, max, mean	
connector_info	Channel (transmitter/probe)	ASCII
channel_type	Parameter details	ASCII
min.	Minimum reading	Numerical, decimal number
max.	Maximum reading	Numerical, decimal number
mean	Mean value	Numerical, decimal number

**production\_options description**

Content of production\_options is a double word type number (32 bit). The individual hardware options are bit-coded here.

xxxx xxxx xxxx xxxx xxx1 2222 3334

- 1 0=2-wire  
1=4-wire
- 2 free
- 3 0=4 to 20 mA  
1=0 to 20 mA  
2=0 to 1 V  
3=0 to 5 V  
4=0 to 10 V

xxxx xxxx xxxx xxxx xxx1 2222 3334

4 0=1 analog output

1=3 analog outputs

**device\_options description**

Content of device\_options is a double word type number (32 bit).  
The individual instrument options are bit-coded here.

xxxx xxxx xxxx xxxx xxx1 1222 2345

1 0=probe is invalid

1=probe is valid

2 free

3 free

4 0=no relay present

1=relay present

5 0=no display

1=display present

**statemsg description**

Content of statemsg is a double word type number (32 bit). The  
individual status messages are bit-coded here.

If statemsg = 0 there are no new messages.

If statemsg != 0

xxxx xxxx xxxx xxxx xxx1 1234 5678

1 free

2 1=probe information

3 1= probe warning

4 1=probe error

5 free

6 1=transmitter information

7 1=transmitter warning

8 1=transmitter error

**staterel description**

Content of staterel is a double word type number (32 bit). The individual relay states are bit-coded here.

xxxx xxxx xxxx xxxx xxxx xxxx xxxx 1234

- 1 0=relay 4 is not set  
1=relay 4 is set
- 2 0= relay 3 is not set  
1=relay 3 is set
- 3 0=relay 2 is not set  
1=relay 2 is set
- 4 0=relay 1 is not set  
1=relay 1 is set

More information can be found in the download area at [www.testo.com](http://www.testo.com).

**4.3.3.5. Adjusting the instrument**

The testo adjusting concept allows the entire signal chain from the sensor signal (probe) and the digital signal (within the transmitter) through to the analog signal (transmitter output signal) to be adjusted (see diagram).

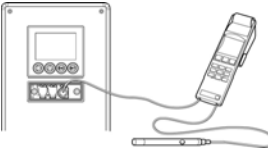
<b>1-point adjustment</b>

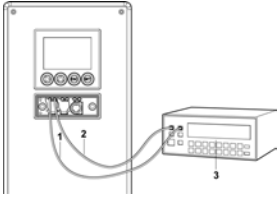
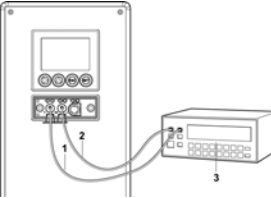
<p>Adjustment via</p> <ul style="list-style-type: none"> <li>• testo 400/650 handheld instrument with adjustment adapter</li> <li>• P2A software</li> <li>• User menu</li> </ul>

Analog adjustment	n-point adjustment
	
<p>Adjustment using a precise multimeter and transmission of analog reference value in</p> <ul style="list-style-type: none"> <li>• User menu or</li> <li>• P2A software</li> </ul>	<p>Adjustment using a precise pressure sensor and transmission of analog reference value in</p> <ul style="list-style-type: none"> <li>• User menu or</li> <li>• P2A software</li> </ul>

The 1-point adjustment is suitable for adjusting the sensor signal - digital signal chain.

The testo 6383 transmitter has digital probes whose adjustment information is stored in the probes' internal memory. The 1-point adjustment can thus be carried out on another testo 6383 (e.g. in the calibration laboratory).

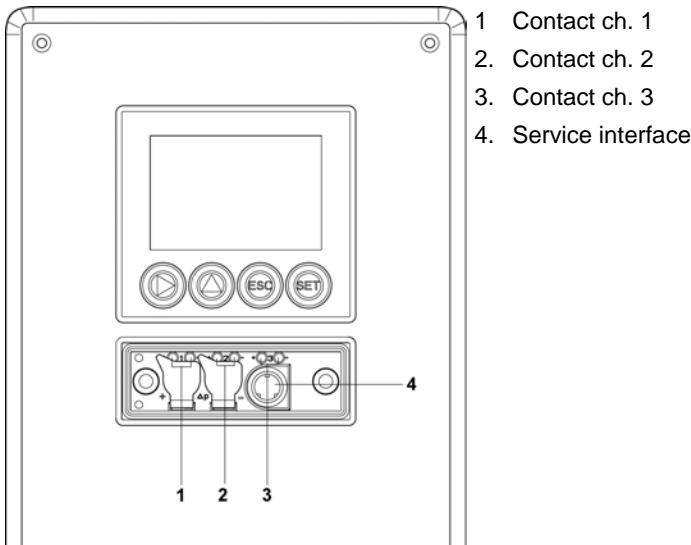
#### 4.3.3.6. Overview: Adjustment keys and test contacts





### 4.3.3.7. 1-point adjustment (offset - humidity/temperature)

In the 1-point adjustment, the reading at the working point is raised to the reference value so that there is no longer any deviation in the working point. The reference condition can be measured using a precise handheld instrument (e.g. testo 400/650 with precision humidity probe) or be created in an air conditioning cabinet.

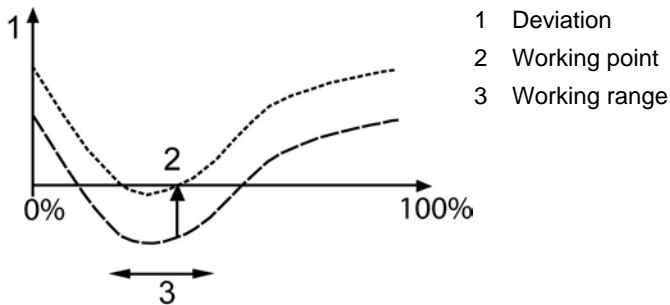

The advantage of the 1-point adjustment is the good measuring result in the working range. But the further away the measurement is from the working point, the greater the deviation can become. The 1-point adjustment should therefore only be used for a relatively narrow measuring range (working range), e.g. clean room applications, air conditioning applications for storage and similar.

The 1-point adjustment can be performed

- via the user menu (see Editing Main Menu Adjust, page 61) or
- via the P2A software (see volume 2, 1-point adjustment, page 135) or
- directly by means of a Testo handheld instrument (testo 400/650) (see description of how to proceed below).

Please note that the 1-point adjustment is generally performed on the basis of the % RH and °C/°F parameters.

#### Adjusting testo 6383 using testo handheld instrument

- ✓ The service flap is open, a testo 400/650 handheld instrument with a precision humidity probe is ready.

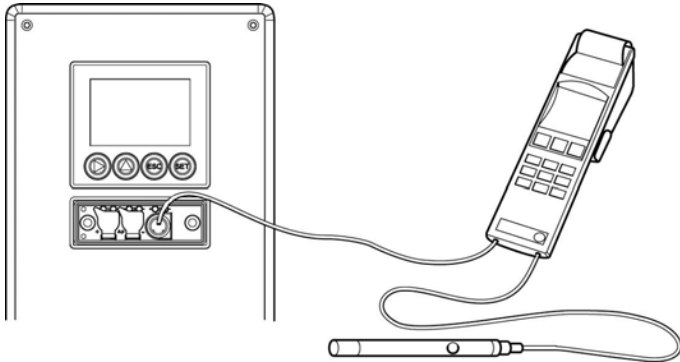

1. Connect testo handheld instrument 400/650 (1) with connected humidity reference probe (3) (order no. reference set 0699 3656/20) to the service interface (5) of the testo 6383 via the adjustment adapter (2) (connected to probe socket 1 of the handheld instrument).
2. Expose the humidity probe (4) of the testo 6383 and the reference probe (3) to the same reference conditions (e.g. in the humidity generator) and allow climatic conditions to equalize.
3. Switch on the testo 400/650. The two-part display of the handheld instrument will show the values of the transmitter on the left, and the values of the reference probe on the right. The humidity and temperature values are adjusted to the reference probe using the **Probe > Probe Adjustment** menu item on the testo 400/650. The 1-point adjustment is performed for both the humidity and the temperature.
4. Disconnect the adjustment adapter (2) from the service interface (5).
5. Close the service flap.

---

**i**

Adjustment with the standard testo adjustment salt pots is not suitable for the testo 6614 (heated for high-humidity applications) and testo 6615 (trace humidity) probes.

The reference conditions should be generated in a humidity generator to adjust these probes. In addition, these probes can also be adjusted at a third adjustment point by Testo Service.

- testo 6614: third adjustment point at 90 % RH
  - testo 6615: third adjustment point at  $-40\text{ }^{\circ}\text{C}_{\text{td}}/-40\text{ }^{\circ}\text{F}_{\text{td}}$
-

### 4.3.3.8. Analog output adjustment

The purpose of adjusting the analog outputs is to adjust the signal chain from the digital signal (within the transmitter) to the analog outputs. The signal type that was appointed for the transmitter is adjusted respectively for each channel (e.g. 4 to 20 mA or 0 to 1 V, etc.).

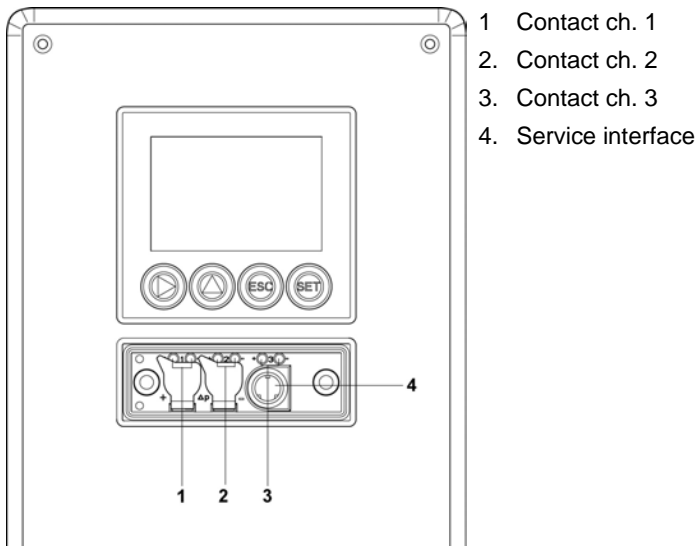

#### Adjusting analog outputs 1, 2 and 3 (optional)

- ✓ With testo 6383 with current output: Load of max. 500  $\Omega$  is connected to channel that is to be adjusted (see Connecting voltage supply and analog outputs, page 23).
- ✓ A precise multimeter (minimum requirement: resolution 6.5 digits, at least 5-times more accurate than the 6383) is available.



If only a simple multimeter is available, the analog outputs must not be adjusted.

---

- ✓ The service cover is open.
- 1. Connect the inputs of the multimeter with the contacts (1) and (2) for channel 1 or with contacts (3) and (4) for channel 2, (5) and (6) for channel 3.

2. Transfer the reference analog value measured with the multimeter into the P2A software (see volume 2, Adjusting the analog output, page 138) or enter it via the user menu (see Editing Main Menu Adjust, page 61).
3. Disconnect connections between the multimeter and the contacts of the testo 6383 and close the service cover.

#### 4.3.3.9. n-point adjustment (pressure)

With an n-point adjustment, the parameters at the 3-6 measurement points are adjusted to the reference value. The reference conditions are obtained by using a precise pressure sensor that should be 5-times more accurate than the transmitter.

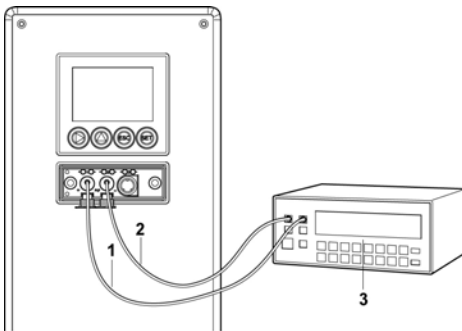

- 1 Positive pressure connection
- 2 Negative pressure connection
- 3 Pressure sensor

---

**i** The number of measuring points is set to 3 by the factory and can only be changed using the P2A software (see **n-point adjustment** page 137)

---

**i** The n-point adjustment must always be carried out to its full extent and in good time at all selected measurement points.

---

- ✓ A precise pressure sensor (5-times more accurate than the transmitter, e.g. DPC precision pressure sensor from testo industrial services) is available.
1. Connect the positive output of the pressure sensor (3) to the positive pressure connection of the transmitter (1) and the negative output of the pressure sensor (3) to the negative pressure connection of the transmitter (2).
  2. Transfer the reference pressure value created with the pressure sensor into the P2A software (see volume 2, n-point adjustment, page 137) or enter it via the user menu (see Editing Main Menu Adjust, page 61).
  3. Repeat step 2 for all of the measuring points.

4. Disconnect connections between the pressure sensor and the pressure connections of the testo 6383.

#### 4.3.3.10. High-humidity adjustment for testo 6614

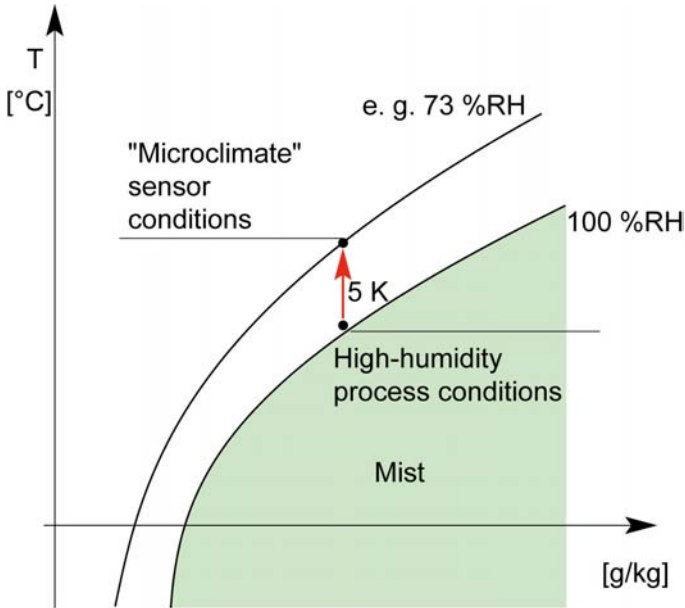

With the testo 6614, the rear of the Testo humidity sensor is heated, creating a microclimate around the sensor (within the filter) that is constantly 5 K warmer than the actual process conditions.

As can be seen in the Mollier diagram, this reduces the relative humidity at the sensor from around 100 % RH to a lower value, e.g. 73 % RH. In this range, the reaction time of the sensor is noticeably shorter than in the condensation range and the risk of the sensor corroding is also reduced. Using the separate temperature probe, the testo 6383 transmitter compensates the microclimate conditions and displays the process readings.



The reference conditions (11.3 % RH and 75.3 % RH) for the 2-point adjustment of the testo 6614 should be generated in a humidity generator, as humidity adjustment sets cannot be used due to the heat generated.

The adjustment can also be carried out at a third adjustment point (90 % RH) by Testo Service so that optimum accuracy is also achieved in the high humidity ranges.

---

#### 4.3.3.11. Self adjustment of testo 6615 trace humidity probe

Conventional trace humidity probes show a steep rise in measuring uncertainty at low humidities. In the testo 6615 trace humidity probe, these measuring uncertainties are corrected by means of an automatic self-adjustment process. This means that extremely accurate measuring results are also attained to  $-60\text{ }^{\circ}\text{Ctd}$ .

To this end, a temperature sensor is fitted on the back of the testo 6615 which is used as a heater. A humidity and temperature value pair is taken in both the unheated and heated state. The deviation of the probe obtained from these pairs of values is automatically corrected.

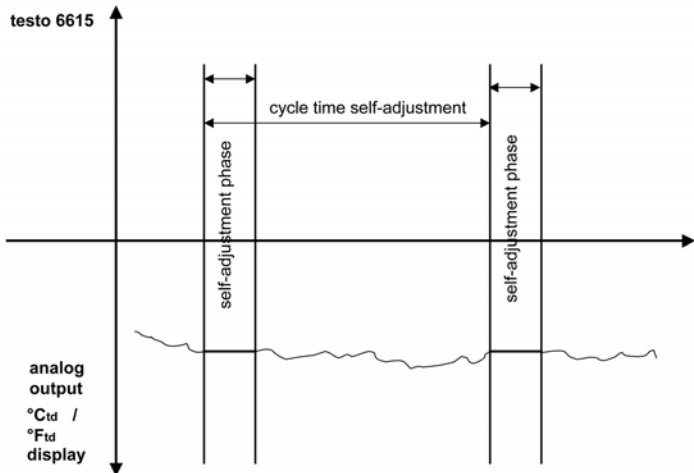

### i

- Deactivating the adjustment function of the testo 6615 will reduce measuring accuracy and should therefore be restricted to the shortest possible length of time.
- During the heating phase, the relay and analog outputs, the display value and output value are "frozen", see diagram above. **Self-adjustment active** is shown in the display until it has finished. The factory setting for self-adjustment time (incl. heating time, calculation time, cooling time) requires 30 minutes daily.
- In the factory setting, a **third adjustment point** ( $-40\text{ }^{\circ}\text{Ctd}$ ) is approached for the testo 6615 in addition to

---

the 2-point adjustment.  
This special adjustment can be performed again by your Testo Service team if necessary.

---

## 4.4. Operation

### 4.4.1. Relationship between user menu and mini-DIN socket is active

The testo 6383 can be parameterized using either the user menu or the P2A software (see volume 2, Parameterizing, adjusting and analyzing software (P2A software) page 113).



The testo 6383 transmitter can only be operated via the display and keypad if the display option is available.

If the testo 6383 is connected to the P2A software, the user menu is blocked for the duration of the communication. The message Service plug is shown in the display of the testo 6383. As soon as the P2A software is disconnected, the user menu is accessible again.

---

### 4.4.2. Password protection

The user menu can be protected with a four-digit numerical code (see Editing Main Menu Settings, page 55) so that access to the user menu is denied to unauthorized persons not familiar with this numerical code.

If the password protection is not to be used, the numerical code "0000" must be entered. This is also the status upon delivery.

### 4.4.3. Structure of user menu

At the main menu level, the user menu comprises the following:

- Main Menu Channel 1
- Main menu of channel 2 (if this option is available)
- Main menu of channel 3 (if this option is available)
- Main Menu Alarm
- Main Menu Settings
- Main Menu Analysis
- Main Menu Messages
- Main Menu Ident
- Main Menu Adjust

- Main Menu Reset

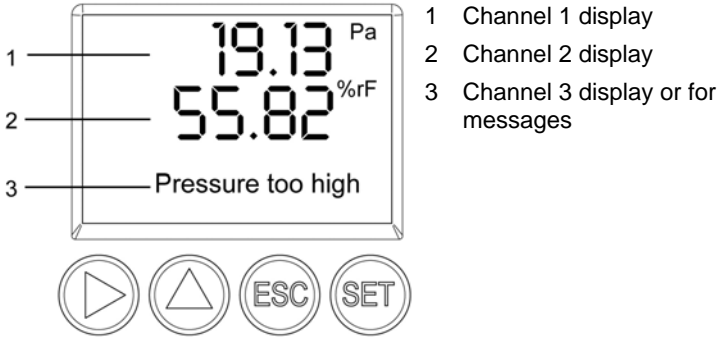

Four keys enable the user to navigate/scroll through the menus and enter/amend values and settings:

Key	Function/description
SET	<ul style="list-style-type: none"> <li>• In Measuring Mode: changes to parameterization</li> <li>• In Parameterizing Mode: confirms a selection or setting</li> </ul>
ESC	<ul style="list-style-type: none"> <li>• Leaves a menu (without modifying any settings)</li> </ul>
▶	<ul style="list-style-type: none"> <li>• Selecting: scrolls through menus (downwards) or selectable alternatives</li> <li>• Editing: changes to next digit (to the right)</li> </ul>
▲	<ul style="list-style-type: none"> <li>• Selecting: scrolls through menus (upwards) or selectable alternatives</li> <li>• Editing: increases the value of the current digit by 1</li> </ul>



### 4.4.4. Overview of the testo 6383 user menu

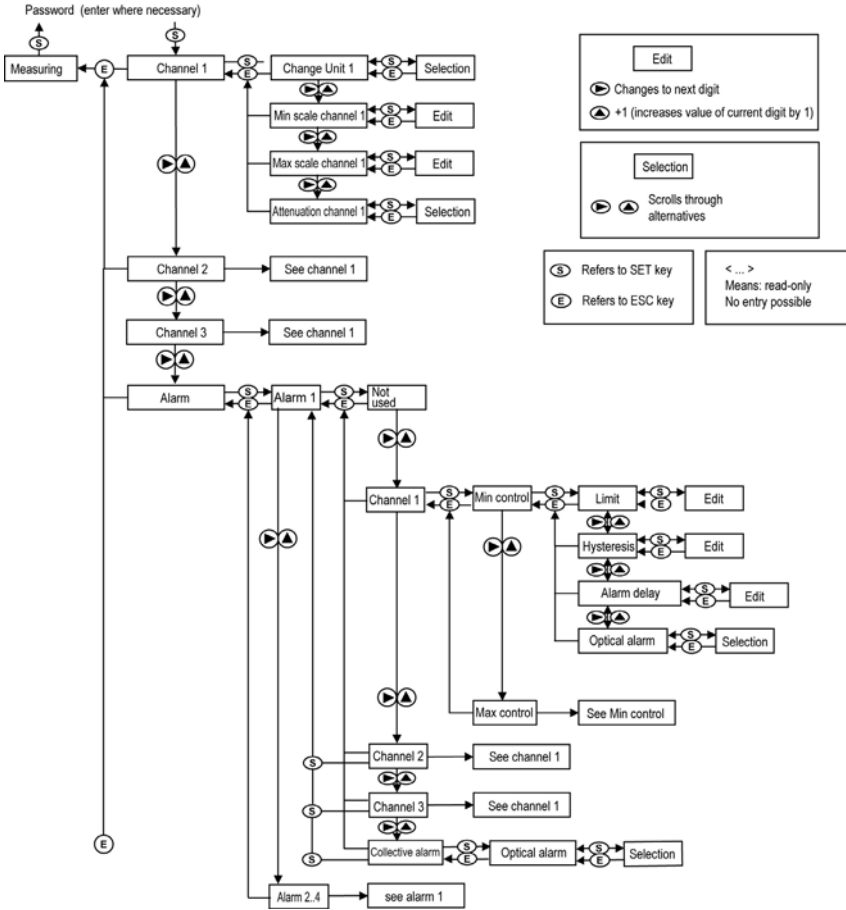

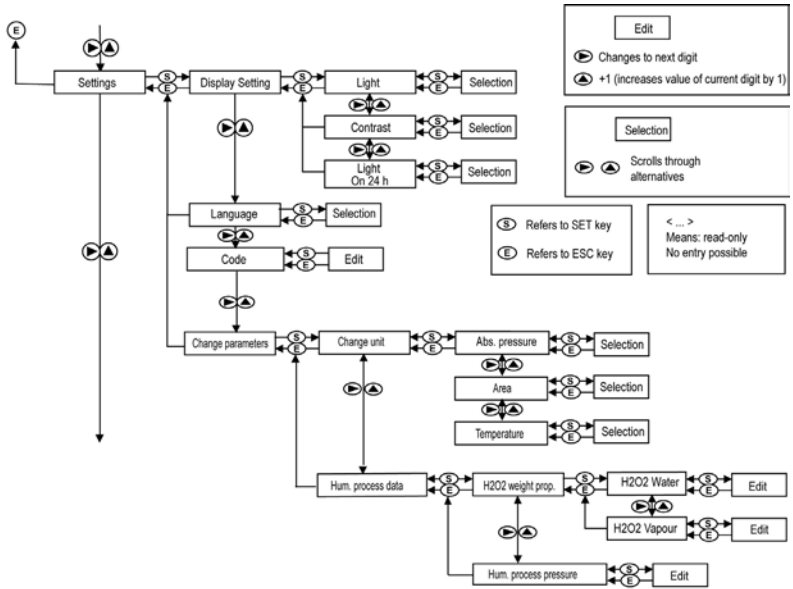

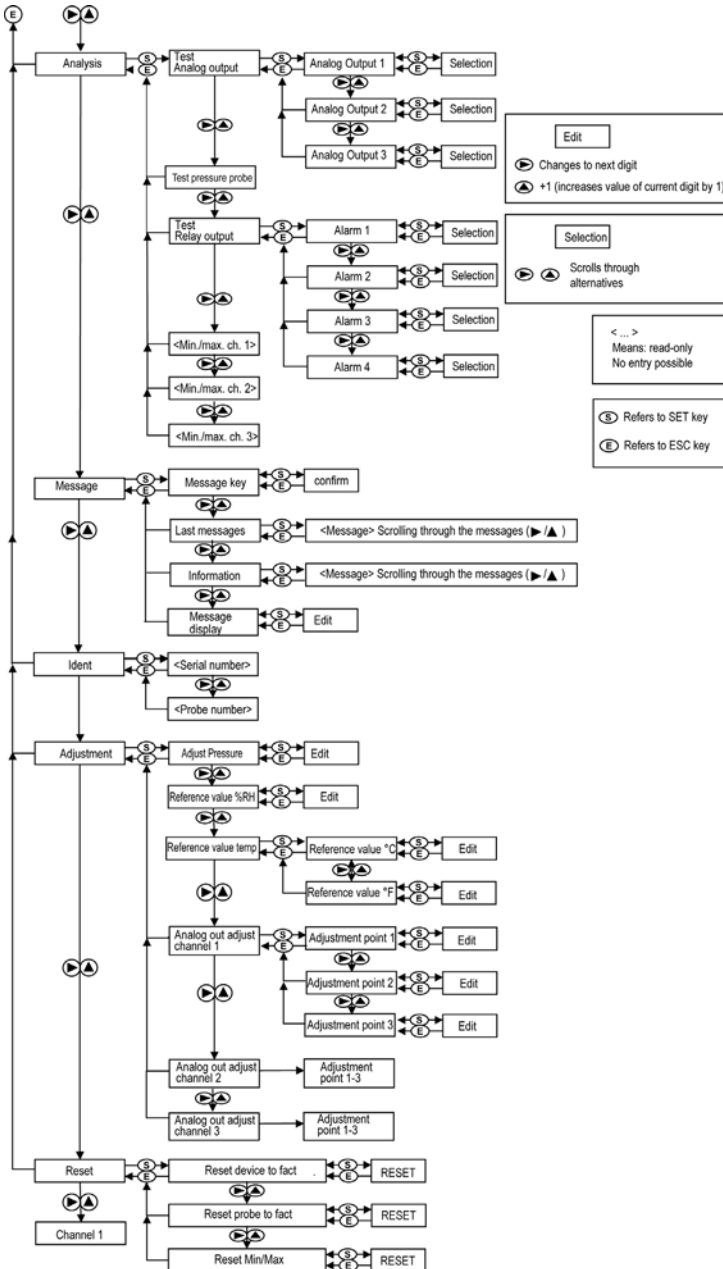

## 4.4.5. The individual main menus

### 4.4.5.1. Editing main menu of channel 1

An overview is given in Overview of the testo 6383 user menu, page 49).

You can perform basic settings for channel 1.

1. In the Measuring Mode press **SET**, select **Main Menu Channel 1** with **▶** or **▲** and confirm selection with **SET**.

One of the following parameters can now be selected using **▶** or **▲**, after which the selection must be confirmed with **SET**:

- Channel 1 Unit

The parameter for this channel is selected.

Edit/select parameter with **▶** or **▲**, confirm with **SET** or abort entry with **ESC**.

- Scale minimum for channel 1:

The lower scale limit is edited; Unit as selected above.

Editing the value: Scroll one digit to the right using **▶** and increase value of digit by 1 using **▲**. Confirm with **SET** or abort entry with **ESC**.

- Scale maximum for channel 1

The upper scale limit is edited;

Unit as selected above.

Editing the value: Scroll one digit to the right using **▶** and increase value of digit by 1 using **▲**. Confirm with **SET** or abort entry with **ESC**.

- Signal delay ("Attenuation") for channel 1

The analog signal can be delayed ("Attenuation"); a time constant is selected for this (1 = no delay; 15 = longest delay)

Edit/select parameter with **▶** or **▲**, confirm with **SET** or abort entry with **ESC**.

2. Continue to the main menu with **▶** or **▲** or return to Measuring Mode with **ESC**.

### 4.4.5.2. Editing Main Menu Channel 2 (if this option is available)

See channel 1.

### 4.4.5.3. Editing Main Menu Channel 3 (if this option is available)

See channel 1.

### 4.4.5.4. Editing Main Menu Alarm

With the alarm, the relays, available as options, are programmed. In addition, the alarm statuses are shown on the display (top right) (even without relays).

You can choose whether the alarm is to be used to monitor limit values or as a collective alarm. If an alarm is to be used to monitor limit values, you can choose between monitoring the minimum or maximum value and set a limit value and hysteresis for each alarm.

In addition, every alarm can be linked to a clearly visible visual alarm (display background lighting flashes).

An alarm delay between 0 and 240 seconds can still be assigned to every alarm used for limit value monitoring so that both the corresponding relay effect and the visual alarm are delayed. If the alarm status goes out within the set alarm delay time, neither the visual alarm nor a relay connection is triggered. .

With an alarm status present, the visual alarm and all relay outputs can be reset by means of acknowledgement. The triggering of a new alarm cannot be enabled until after the alarm status goes out.

1. In the Measuring Mode press **SET**, select **Main Menu Alarm** with ► or ▲ and confirm selection with **SET**.
  - Four alarms can be parameterized.
2. Select **Alarm x** with ► or ▲ and confirm selection with **SET**.

#### Using alarm to monitor limit values

##### NO contact

Monitoring minimum

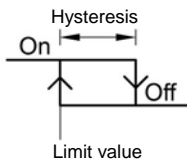

Monitoring maximum

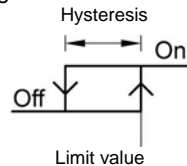

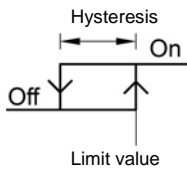
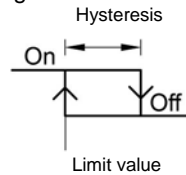
**NC contact****Monitoring minimum****Monitoring maximum**

3. Select **Channel x** (e.g. "Channel 1") with ► or ▲ and confirm selection with **SET**.
4. Select **Max control** or **Min control** with ► or ▲ (see graphic).
5. Press **SET** and edit **Limit value** as well as **Hysteresis**: Scroll one digit to the right using ► and increase value of digit by 1 using ▲. Confirm with **SET** or abort entry with **ESC**.
6. Select **Visual alarm** with ► or ▲. Select **YES** or **NO** with ► or ▲. Confirm with **SET** or abort entry with **ESC**.
7. Press **SET** and edit **Alarm delay**: Scroll one digit to the right using ► and increase value of digit by 1 using ▲ (0 to 240 seconds possible). Confirm with **SET** or abort entry with **ESC**.
8. Return to **Channel x** with **ESC**.
9. Return to **Alarm x** with **ESC**.
10. Change to the other relays using ► or ▲ and perform settings in the same way.

**Using alarm as collective alarm or not using it at all**

If an alarm is assigned to the collective alarm, the relay is switched and a visual alarm can be issued via the display as soon as (at least) one of the warning or error messages of the testo 6383 transmitter (or the connected testo 6610 probe) becomes active.

**i** The messages affecting the collective alarm can only be selected in the P2A software, see volume 2, Using the software, page 116.

- ✓ Alarm is selected (see previous steps 1 and 2).
1. Use ► or ▲ to determine whether **Alarm x** should be used as a **Collective alarm** or **not used**. Confirm selection with **SET**.
  2. If collective alarm is selected: Select **Visual alarm** with ► or ▲. Select **YES** or **NO** with ► or ▲. Confirm with **SET** and return to **Alarm x**.

3. Change to another alarm using ► or ▲ and perform settings in the same way.
4. Return to **Main Menu Alarm** with **ESC**.
5. Continue to **Main Menu Settings** with ► or ▲ or return to Measuring Mode with **ESC**.

#### 4.4.5.5. Editing Main Menu Settings

You can edit instrument settings and other settings.

- > In Measuring Mode, press **SET**, select **Main Menu Settings** using ► or ▲ and confirm selection with **SET**.

You can edit settings for:

- Display
- Language
- Code
- Units
  - Absolute pressure
  - Area
  - Temperature
- Humidity process data
  - H<sub>2</sub>O<sub>2</sub> percentage by weight
  - Humidity process pressure

#### Editing display settings

You can set the brightness and contrast of the display.

1. Select **Display Settings** with ► or ▲ and confirm selection with **SET**.
2. Select **Backlight** or **Contrast** with ► or ▲ and confirm selection with **SET**.

One of the following parameters can now be selected using ► or ▲, after which the selection must be confirmed with **SET**:

- **Backlight**

The display illumination is changed.

Edit/select parameter with ► or ▲, confirm with **SET** or cancel entry with **ESC** (the effect of the change in parameter can be seen during input).

- **Contrast**

The brightness difference between the display background and the displayed values is changed.

Edit/select parameter with ► or ▲, confirm with **SET** or cancel entry with **ESC** (the effect of the change in parameter can be seen during input).

- **Backlight 24h on**

Select **On** or **Off** using ► or ▲ and confirm with **SET**.

Off: The display light switches off automatically if no button was pressed for 10 seconds.

On: The display light is activated

3. Return to **Display Settings** with **ESC** and use ► or ▲ to continue to **Language**.

### Selecting language

You can select the language for the plain text line in the display.

- > Press **SET**, select required language with ► or ▲, confirm selection with **SET** and return to **Language**.



Only choose a language that you can understand well.

---

### Editing code settings

You can set the access code (password).



If a code other than "0000" (factory setting) is set, the transmitter can only be operated once this code has been entered via the menu.

---

1. Select **Code** with ► or ▲ and confirm selection with **SET**.
2. Scroll one digit to the right using ► and increase value of digit by 1 using ▲. Confirm with **SET** or abort entry with **ESC**.
3. Return to **Code** with **ESC** and use ► or ▲ to continue to **Change parameters**.

### Select unit (Change unit)

This setting affects the displayed unit of all readings.

1. Press **SET**, select **Change parameters** with ► or ▲, confirm selection with **SET** or cancel with **ESC**.
2. Select **Change unit** with ► or ▲, confirm selection with **SET** or cancel with **ESC**.



3. Select the required variable (absolute pressure/area/temperature) with ► or ▲, confirm selection with **SET** or cancel with **ESC**.
4. Select the required unit with ► or ▲, confirm selection with **SET** or cancel with **ESC**.
5. Return to **Change unit** with **ESC**.
6. Return to **Change parameters** with **ESC**.
7. Return to **Main Menu Settings** with **ESC**.

### Editing Humidity process data

This menu is only used to parameterize humidity measurements in H<sub>2</sub>O<sub>2</sub> atmospheres (e.g. in sterilization processes) and determines whether °Ctm or °Ftm is the output parameter.

1. Select **Humidity process data** with ► or ▲ and confirm selection with **SET**.
2. Select **H2O2 weight prop.** with ► or ▲, confirm selection with **SET** or cancel with **ESC**.  
The selection **H<sub>2</sub>O<sub>2</sub> water** or **H<sub>2</sub>O<sub>2</sub> vapour** in the submenu describes whether H<sub>2</sub>O<sub>2</sub> is generated by means of evaporation or is actively vaporized in the process.
3. Select **H<sub>2</sub>O<sub>2</sub> water** or **H<sub>2</sub>O<sub>2</sub> vapour** with ► or ▲ and confirm with **SET**.
4. Edit proportion by weight of the H<sub>2</sub>O<sub>2</sub> in % (% H<sub>2</sub>O<sub>2</sub> proportion by weight in the liquid initial solution): Scroll one digit to the right using ► and increase value of digit by 1 using ▲. Confirm with **SET** or abort entry with **ESC**.
5. Return to **H2O2 weight prop.** with **ESC** and use ► or ▲ to continue to **Humidity process pressure**.
6. Select **Humidity process pressure** with ► or ▲ and confirm selection with **SET**.
7. Edit humidity process pressure: Scroll one digit to the right using ► and increase value of digit by 1 using ▲. Confirm with **SET** or abort entry with **ESC**.
8. Return to **Change parameters** with **ESC**.
9. Return to **Main Menu Settings** with **ESC**.

#### 4.4.5.6. Editing Main Menu Analysis

You can test the functionality of analog and relay outputs. In addition, you can read off the minimum and maximum values (since the last voltage supply or reset of the min./max. values).

##### Testing functionality of analog outputs

**i** This function affects the analog outputs directly, not only the test contacts.

1. In the Measuring Mode press **SET**, select main menu **Analysis** with **▶** or **▲** and confirm selection with **SET**.
  - **Test Analog Output** is shown.
2. Press **SET** and choose between **Analog output 1, 2, 3** with **▶** or **▲**.
3. Press **SET**, scroll one digit to the right using **▶** and increase value of digit by 1 using **▲**. Any analog output value can be predefined, e.g. for an analog output of 4 to 20 mA, the value "6.0 mA". Confirm with **SET** or abort entry with **ESC**.
4. Accept setting by pressing **SET** and test with multimeter (minimum requirement: resolution 6.5 digits, at least 2-times more accurate than the 6383) as follows:

Analog output 1, 2 or 3: Via test contacts under service cover, see diagram.

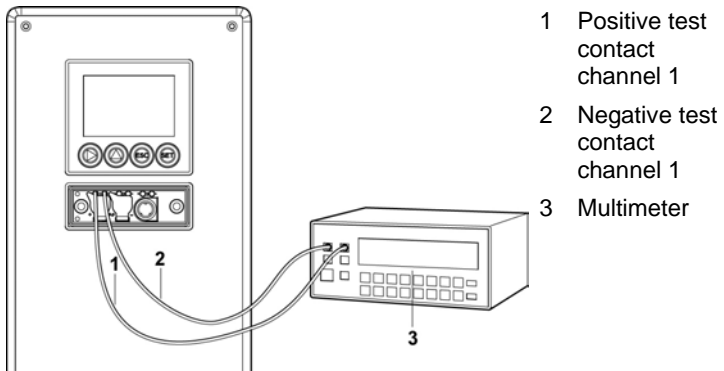

4. Return to **Test Analog Output** with **ESC** and use **▶** or **▲** to continue to Test Relay Output.

---

### Testing functionality of the pressure sensor (**Test pressure sensor**)

---



This function is only required to calibrate the pressure sensor.

---

### Testing functionality of relay outputs

1. Press **SET** and choose between **Alarm 1, 2, 3, 4** with ► or ▲.
2. Press **SET**.

The relay can now be tested. You can choose between **OFF** and **ON** using ► or ▲. If **ON** is chosen, the NO contact is closed, the NC contact opened. If **OFF** is chosen, the NC contact is closed, the NO contact opened.

3. To test, route a measuring cable from the relay terminals (see Connecting the relay outputs, page 24) out of the transmitter to a multimeter (resistance measurement) or continuity tester.
4. Return to **Test Relay Output** with **SET** (starts relay test) or **ESC** (exits the menu without relay test).

### Reading off min./max. values of channels

To reset the max./min. values, see Editing Reset main menu, page 63

1. Read off the min./max. values of the three channels in succession with ► or ▲ and return to the Main Menu Analysis with **ESC**.
2. Continue to **Main Menu Message** with ► or ▲ or return to Measuring Mode with **ESC**.

#### 4.4.5.7. Editing Message main menu

Messages can be confirmed/acknowledged, the last messages can be called up and the display of the messages can be switched on or off.

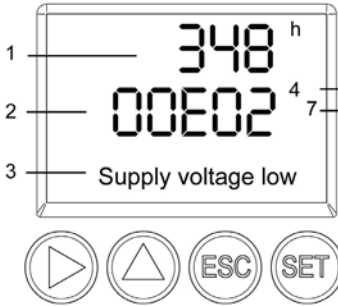

- 1 Operating hours at the time of message
- 2 Message code (see Status, warning and error messages, page 64).
- 3 Message text
- 4 Message number (example: "4/7" refers to the fourth of seven messages)
- 5 Number of messages present (example: "4/7" refers to the fourth of seven messages)

**i** Using the P2A software (see volume 2, Parameterizing, adjusting and analyzing software (P2A software), page 113) you can predefine whether messages are to be shown in the display.

1. In the Measuring Mode press **SET**, select **Main Menu Message** with **▶** or **▲** and confirm selection with **SET**.
2. Confirm **Confirm message** using **SET**.
3. Select **Last messages** with **▶** or **▲** and confirm with **SET**.
4. Scroll between the warning and error messages recorded so far using **▶** or **▲** and return to **Last messages** using **ESC**.
5. Select **Information** with **▶** or **▲** and confirm with **SET**.
6. Scroll between the status messages recorded so far using **▶** or **▲** and return to **Information** using **ESC**.
7. Continue to **Display of message** with **▶** or **▲**.  
**ON**: Measurements are shown on the display in Measuring Mode.  
**OFF**: No messages shown on display.
8. Select **ON** or **OFF** with **▶** or **▲** and confirm selection with **SET**.
9. Return to **Main Menu Message** with **ESC**.

10. Continue to **Main Menu Ident** with **▶** or **▲** or return to Measuring Mode with **ESC**.



An overview of the messages can be found in Status, warning and error messages, page 64

#### 4.4.5.8. Calling up Main Menu Ident

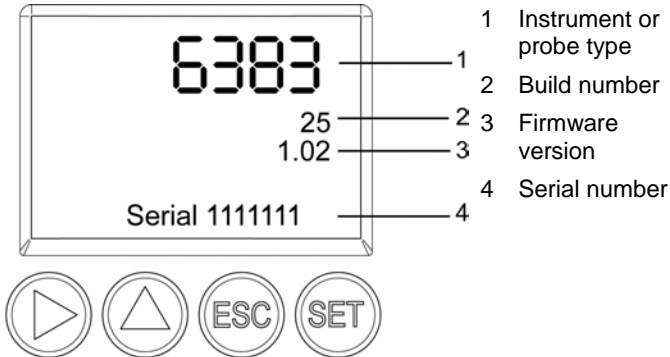

The serial numbers of the transmitter and probe can be read off.

1. In the Measuring Mode press **SET**, select **Main Menu Ident** with **▶** or **▲** and confirm selection with **SET**.
- The type, firmware version, build number and serial number of the transmitter are displayed.



This information is required when servicing.

2. Return to **Main Menu Ident** with **ESC** or read off the type, firmware release, build number and serial number of the probe with **▶** or **▲** and then return to **Main Menu Ident** with **▶** or **▲**.
3. Continue to **Main Menu Adjust** with **▶** or **▲** or return to Measuring Mode with **ESC**.

#### 4.4.5.9. Editing Main Menu Adjust

A reference value can be entered for both relative humidity (RH) and temperature (°C/°F) for the 1-point adjustment. Please refer to the description in 1-point adjustment (offset - humidity/temperature), page 41

Reference values for pressure can be entered for the n-point adjustment. Please refer to the description in n-point adjustment (pressure), page 44

In addition, the analog outputs can be adjusted. Also see Analog output adjustment, page 43 for instructions on how to do this.

### Enter reference value for 1-point adjustment

Please also refer to 1-point adjustment (offset - humidity/temperature), page 41

1. In the Measuring Mode press **SET**, select main menu **Adjust** with **▶** or **▲** and confirm selection with **SET**.
  - **Reference value % RH** is displayed.
2. Press **SET**, edit value: Scroll one digit to the right using **▶** and increase value of digit by 1 using **▲**. Confirm with **SET** or abort entry with **ESC**.
3. Continue to **Reference value temp** with **▶** or **▲**.
4. Press **SET**, **Reference value °C** or **Reference value °F** is displayed.
5. Press **SET**, edit value: Scroll one digit to the right using **▶** and increase value of digit by 1 using **▲**. Confirm with **SET** or abort entry with **ESC**.
6. Continue to **Analog Adj. Ch. 1** with **▶** or **▲**.
7. Continue with the adjustment of the analog outputs (see below, step 2) or press **ESC** to return to main menu **Adjust**.
8. Continue to main menu **Reset** with **▶** or **▲** or return to Measuring Mode with **ESC**.

### Performing analog adjustment

Please refer to Analog output adjustment, page 43.

1. In the Measuring Mode press **SET**, select main menu **Adjust** with **▶** or **▲** and confirm selection with **SET**.



Each channel is adjusted at three points in the analog range (at 10 %; 50 %; 90% of the analog scale).

---

2. Select **Analog Adj. Ch. 1** with **▶** or **▲** and confirm with **SET**.
3. Use **▶** or **▲** to select **Adj. Point 1**.
4. Press **SET**. Read off multimeter display (e.g. 5601 mA) and enter this value in the user menu. Do this by scrolling one digit to the right using **▶** and increasing the value of digit by 1 using **▲**. Confirm with **SET** or abort entry with **ESC**.
5. Use **▶** or **▲** to select **Adj. Point 2**.
6. Press **SET**. Read off multimeter display (e.g. 12,001 mA) and enter this value in the user menu. Do this by scrolling one digit

- to the right using **▶** and increasing the value of digit by 1 using **▲**. Confirm with **SET** or abort entry with **ESC**.
7. Use **▶** or **▲** to select **Adj. Point 3**.
  8. Press **SET**. Read off multimeter display (e.g. 18,401 mA) and enter this value in the user menu. Do this by scrolling one digit to the right using **▲** and increasing the value of digit by 1 using **▶**. Confirm with **SET** or abort entry with **ESC**.
  9. With **▶** or **▲** continue to **Analog Adj. Ch. 2 or 3** (repeat steps 3 to 8).
  10. Return to main menu **Adjust** with **ESC**.
  11. Continue to main menu **Reset** with **▶** or **▲** or return to Measuring Mode with **ESC**.

### Performing the pressure adjustment

Please refer to n-point adjustment (pressure), page 44

1. In the Measuring Mode press **SET**, select main menu **Adjust** with **▶** or **▲** and confirm selection with **SET**.



The pressure adjustment can be performed at 3 to 6 adjustment points.

2. Select **Adjust Pressure** with **▶** or **▲** and confirm with **SET**.
3. Use **▶** or **▲** to select **Adj. Point 1**.
4. Press **SET**. Read off pressure sensor display (e.g. 30.1 Pa) and enter this value in the user menu. Do this by scrolling one digit to the right using **▶** and increasing the value of digit by 1 using **▲**. Confirm with **SET** or abort entry with **ESC**.
5. Repeat steps 1 to 4 for adjustment points 2 to 6.
6. Return to main menu **Adjust** with **ESC**.
7. Continue to main menu **Reset** with **▶** or **▲** or return to Measuring Mode with **ESC**.

#### 4.4.5.10. Editing Reset main menu

You can reset the factory settings for the following:

- Instrument
- Sensor/probe
- Min./max. values



Resetting to the factory settings means resetting to the order specification, i.e. the specific condition at the time of supply to the customer.

---

1. In the Measuring Mode press **SET**, select **Main Menu Reset** with **▶** or **▲** and confirm selection with **SET**.
  - **Reset Device** to factory settings is displayed.
2. Select the setting to be reset using **▶** or **▲** and confirm selection with **SET**.
  - **Reset Completed** is displayed.
3. Return to the reset setting with **ESC** or **SET** and return to **Main Menu Reset** with **ESC**.
4. Continue to **Main Menu Channel 1** with **▶** or **▲** or return to Measuring Mode with **ESC**.

## 4.5. Status, warning and error messages

To achieve optimum operational reliability (machine availability), the transmitter shows the following via the user menu or the P2A software

- Status messages
- Warning messages
- Error messages

The status and warning messages for the respective testo 6610 probes connected to the transmitter can be evaluated via the P2A software.

All messages are stored in the transmitter with an operating hours stamp. Use the user menu (see Editing Message main menu, page 60) or the P2A software (see volume 2, Transmitter history, page 139) to view the message history.

In the transmitter, the last 60 status messages and the last 120 error and warning messages are stored in a ring memory. There is no limit in the P2A software.



### 4.5.1. Status messages

Status messages show the current operating status of the testo 6383.

Message	Display	Description
02506	Sensor initialization	Message appears while the transmitter is starting up. If the message disappears, the transmitter is ready for operation.
01D19	Service plug	The Mini-DIN socket is connected to: the USB adapter for P2A software, the adjustment adapter or the service plug (is not recorded/no number)
00300	New limit value	The limit value has been changed or shifted
00301	Scaling changed	The scaling has been changed
00500	Transmitter reset	The transmitter was reset to the factory settings and is restarted.
0052F	Reset Min/Max	Resets all saved Min/Max values for all channels
02518	Probe reset	Probe reset: The probe performs a reset
00503	Reset device to fact	A factory reset of the transmitter was performed
02503	Reset probe to fact	A factory reset of the probe was performed
00530	Change solenoid valve	The solenoid valve should be changed
00307	User Setting Change	User Setting Change: General settings were changed for the transmitter.
00117	Adjustment DeltaP	An n-point adjustment was performed.
02104	Analog adjustment	An analog adjustment has been made
02101	1-point adjustment	A 1-point adjustment is performed.

Message	Display	Description
02105	Self-adjustment active	For testo 6615 probe only: The probe performs an automatic self-adjustment

## 4.5.2. Warning messages

Warning messages show an early warning or a current malfunction which may negatively impact measuring.

Message	Display	Cause	Remedying of fault
00809	Pressure too high**	The process pressure exceeds the pressure intended for the transmitter	Remove the transmitter from the process and take any necessary measures to lower the pressure
00E00	T ambient high**	The ambient temperature exceeds the permissible temperature for the transmitter	Take necessary measures to lower ambient temperature, e.g. through venting or cooling
00E01	T ambient low**	The ambient temperature is below the permissible temperature for the transmitter	Take necessary measures to raise ambient temperature, e.g. through heating
00E04/00E05	Supply voltage low**	The supply voltage is below the minimum voltage required for the transmitter	Take measures to ensure sufficient voltage supply
02822	T process high**	The process temperature exceeds the temperature designated for the probe	Remove the probe from the process and take any necessary measures to lower the process temperature
02821	T process low**	The process temperature is below the temperature designated for the probe	Take necessary measures to raise process temperature
0081C	Alarm 1**	Depending on the parameterization of the relays	Depending on the parameterization of the relays

Message	Display	Cause	Remedying of fault
0081D	Alarm 2**	Depending on the parameterization of the relays	Depending on the parameterization of the relays
0081E	Alarm 3**	Depending on the parameterization of the relays	Depending on the parameterization of the relays
0081F	Alarm 4**	Depending on the parameterization of the relays	Depending on the parameterization of the relays
02806	Condensation*	100 % RH has been reached, condensation developing	Take measures to reduce process humidity
02807	Values less than 0 % RH**	The adjustment or sensor is faulty	Check adjustment (via P2A adjustment history, perform 2-point adjustment where necessary). If the problem persists, contact Testo Service
02809	Sensor early warning*	For testo 6617 probe only: The cover electrode of the sensor is damaged; this may soon cause the sensor to break	Carry out visual inspection. If the mirror-like surface of the sensor is dirty or damaged, contact Testo Service

\* Early warning

\*\* Current malfunction

### 4.5.3. Transmitter error messages

Error messages show a current malfunction.

Message	Display	Cause	Remedying of fault
03401	No probe signal	The probe communication is interrupted	Ensure that the probe connector is fully engaged in the transmitter.  If communication still cannot be established, contact Testo Service

<b>Message</b>	<b>Display</b>	<b>Cause</b>	<b>Remedying of fault</b>
03508	Wrong probe	The connected probe is not compatible with the present transmitter	Use a compatible probe Note: Probe 661x for transmitter 638x
01505	Watchdog error	Due to a processor error, the transmitter performs an automatic restart	If the problem occurs frequently, contact Testo Service
0300A	% RH short-circuit	Short-circuit in humidity sensor	Contact Testo Service
0300B	% RH sensor broken	The humidity sensor is damaged (sensor broken)	Contact Testo Service
0300C	T short-circuit	Short-circuit in temperature sensor	Contact Testo Service
0300D	T sensor broken	The temperature sensor is damaged (sensor broken)	Contact Testo Service
03105	Self-adjustment error	For testo 6615 probe only: The automatic self-adjustment was faulty	Contact Testo Service
03106	Adjustment error	The adjustment of the probe was faulty	Contact Testo Service
01115	Low adjustment temperature	The ambient temperature is too low during the pressure adjustment	Take necessary measures to raise ambient temperature, e.g. through heating
01116	High adjustment temperature	The ambient temperature is too high during the pressure adjustment	Take necessary measures to lower ambient temperature, e.g. through venting.
03000	Heat function defective	For testo 6614 probe only: Heat function defective	Contact Testo Service

#### 4.5.4. Handling alarm messages

Shown on the display <sup>4</sup>	Can be used for collective alarm <sup>5</sup>	Additional message end <sup>6</sup>
New limit value	x	
Scaling changed	x	
Pressure too high	x	x
Delta p adjustment	x	
Alarm 1		x
Alarm 2		x
Alarm 3		x
Alarm 4		x
Transmitter reset	x	
Reset Min/Max		
Transmitter refresh	x	
User Setting Change		
Analog adjustment	x	
1-point adjustment	x	
Probe reset	x	
T ambient high	x	x
T ambient low	x	x
Supply voltage low	x	x
T process high	x	x
T process low	x	x

<sup>4</sup> If multiple messages/alarms are activated at the same time, only the last message/alarm is shown. If this is cancelled, the other messages that are still active are no longer displayed.

<sup>5</sup> The message can be assigned the collective alarm function, which means that the collective alarm is activated as soon as at least one of the messages assigned to it is activated. The collective alarm can be assigned to each of the 4 optional relays. The collective alarm is then always the same, as it can only be defined once.

<sup>6</sup> The message is shown upon the occurrence of the event causing the message as well as when closing. Two entries appear in the history in the P2A software: Message text\_start and Message text\_end.

Shown on the display <sup>4</sup>	Can be used for collective alarm <sup>5</sup>	Additional message end <sup>6</sup>
Condensation	x	x
Values less than 0 % RH	x	x
Sensor early warning	x	
No probe signal	x	
Watchdog error	x	
% RH short-circuit	x	x
% RH sensor broken	x	x
T short-circuit	x	x
T sensor broken	x	x
Heat function defective	x	x

Perform the **Confirm message** function (acknowledgement of the alarm via the control keys on the transmitter):

- The message/alarm is no longer shown on the display and the optical alarm goes out, where applicable. If multiple messages/alarms are active at the same time, all are reset simultaneously.
- If at least one message is assigned to the collective alarm, the collective alarm is reset. If the collective alarm is set on a relay, the relay is also reset, meaning switched to its neutral position.

### 4.5.5. Namur fault conditions

If the faults named in the following table occur, the analog outputs output special values that enable a general fault warning in the higher-level control system. The values correspond to the "Namur" industry standard.

Status message in the display	Display value in display	Class	Analog output				
			0 to 20 mA	4 to 20 mA	1 V	5 V	10 V
No probe signal	None	Error	21 mA	21 mA	1.1 V	5.5 V	11 V
Wrong probe	None	Error	21 mA	21 mA	1.1 V	5.5 V	11 V
Values < 0 %RH	uuuuu	Underrange	0 mA	3.8 mA	0 V	0 V	0 V
Condensation	ooooo	Overrange	20.5 mA	20.5 mA	1.1 V	5.5 V	11 V
% RH short-circuit	-----	Error	21 mA	21 mA	1.1 V	5.5 V	11 V
% RH sensor broken	-----	Error	21 mA	21 mA	1.1 V	5.5 V	11 V
T short-circuit	-----	Error	21 mA	21 mA	1.1 V	5.5 V	11 V
T sensor broken	-----	Error	21 mA	21 mA	1.1 V	5.5 V	11 V
T process low	uuuuu	Underrange	0 mA	3.8 mA	0 V	0 V	0 V
T process high	ooooo	Overrange	20.5 mA	20.5 mA	1.1 V	5.5 V	11 V
Probe disconnected	None	Error	21 mA	3.8 mA	1.1 V	5.5 V	11 V
Watchdog error	Previous value stops	Error	21 mA	3.8 mA	1.1 V	5.5 V	11 V
Value below min. scale	Reading	Underrange	0 mA	3.8 mA	0 V	0 V	0 V
Value above max. scale	Reading	Overrange	20.5 mA	20.5 mA	1.1 V	5.5 V	11 V
Pressure too high	ooooo	Overrange	20.5 mA	20.5 mA	1.1 V	5.5 V	11 V

Status message in the display	Display value in display	Class	Analog output				
Heat function defective	-----	Error	21 mA	21 mA	1.1 V	5.5 V	11 V

## 4.6. Maintenance and cleaning

### 4.6.1. Maintaining the instrument

We recommend that the adjustment and settings of the transmitter be checked at regular intervals using the

- User menu (Operation, page 47) or
- P2A software (volume 2, Parameterizing, adjusting and analyzing software (P2A software), page 113)

Convenient "remote monitoring" of the transmitter can be implemented, for example by using a relay as a collective alarm (see Using alarm as collective alarm or not using it at all, page 54) whose messages are forwarded to a local alarm transmitter (horn, light) or PLC.

### 4.6.2. Cleaning the instrument

#### Integrated humidity probe

The humidity sensor of the integrated humidity probe in particular must be protected.

---

**i** The sensors of the integrated humidity probe must not make contact with cleaning agents, otherwise the functionality can no longer be guaranteed.

---

1. Put supplied plastic cap on the integrated humidity probe.
2. Wipe surface of the instrument with mild cleaning agents and a soft cloth.
3. Remove plastic cap.



### **Instrument surface**

- ✓ Integrated humidity probe is protected by the plastic cap.
- Clean the surface of the instrument with mild cleaning agents (e.g. washing-up liquid) and water. Only use gentle and standard cleaners.
- Do not use any aggressive or chafing cleaning agents such as thinner, liquid scouring agent, wax, benzine, concentrated acids and lyes.
- Carefully rub down the instrument surface with a moist and soft cloth.





