

Rosemount 5600 Series Radar Level Transmitter with HART[®] and FOUNDATION[™] fieldbus protocol



ROSEMOUNT[®]

www.rosemount.com



EMERSON[™]
Process Management

Rosemount 5600 Series Radar Level Transmitter

NOTICE

Read this manual before working with the product. For personal and system safety, and for optimum product performance, make sure you thoroughly understand the contents before installing, using, or maintaining this product.

Within the United States, Rosemount Inc. has two toll-free assistance numbers.

Customer Central: 1-800-999-9307 (7:00 a.m. to 7:00 p.m. CST)

Technical support, quoting, and order-related questions.

North American Response Center: 1-800-654-7768 (24 hours a day – Includes Canada)
Equipment service needs.

⚠ CAUTION

The products described in this document are NOT designed for nuclear-qualified applications.

Using non-nuclear qualified products in applications that require nuclear-qualified hardware or products may cause inaccurate readings.

For information on Rosemount nuclear-qualified products, contact your local Rosemount Sales Representative.

*Rosemount and the Rosemount logotype are registered trademarks of Rosemount Inc.
PlantWeb is a registered trademark of the Fisher-Rosemount group of companies.
HART is a registered trademark of the HART Communication Foundation.
Teflon, VITON, and Kalrez are registered trademarks of E.I. du Pont de Nemours & Co.
FOUNDATION is a trademark of the Fieldbus Foundation.
DeltaV is a trademark of Emerson Process Management group of companies.
All other marks are the property of their respective owners.
Cover Photo: 5600_01ad*

Table of Contents

SECTION 1	
Introduction	
	Safety Messages 1-1
	Overview 1-2
	Specific FCC Requirements (USA only) 1-6
	Measuring Range 1-7
	Unpacking your 5600 Transmitter 1-8
	Service Support 1-9
	Within USA: 1-9
	Outside USA: 1-9
SECTION 2	
Mechanical Installation	
	Safety Messages 2-1
	Introduction 2-2
	Tools 2-2
	General Installation Requirements 2-2
	Customer Supplied Flanges 2-2
	Nozzle Requirements 2-3
	Free Space Requirements 2-4
	Beam Width 2-5
	Special Antennas and Space Requirements Reference 2-5
	Wave Guide Tubes 2-6
	Mounting the Rod Antenna, Flanged Version 2-7
	Mounting the Rod Antenna, Threaded Version 2-11
	Mounting the Cone Antenna - PTFE sealing 2-14
	Mounting the Cone Antenna - Quartz sealing 2-17
	Mounting the Process Seal Antenna 2-22
	Mounting the Cone Antenna in a Still-pipe/Bridle 2-25
	For Still Pipes 2-26
	For Bridle Pipes 2-27
	Mounting the Antenna 2-29
	Mounting the Parabolic Antenna 2-31
	Mounting the Extended Cone Antenna 2-37
	Setting the Tank Connection Length (TCL) 2-38
	Setting the Hold Off Distance 2-39
	Installation Requirements Extended Cone Antenna 2-40
	Mounting the Cone Antenna with Flushing Connections 2-43
SECTION 3	
Electrical Installation	
	Safety Messages 3-1
	System Overview 3-2
	Cables 3-3
	Power Supply 3-3
	Grounding 3-4
	HART Electrical Installation 3-4
	External Connections 3-4
	Connecting HART devices 3-6

Rosemount 5600 Series

	FOUNDATION Fieldbus Electrical Installation	3-8
	Power Supply	3-8
	Fieldbus Connections	3-9
	Model Code	3-9
	External Connections	3-9
	Hazardous Locations	3-10
	Grounding	3-10
	Connecting fieldbus devices	3-11
	Connecting the 2210 Display Unit	3-12
	Temperature Measurement	3-14
SECTION 4		
Configuration		
	Safety Messages	4-1
	Overview	4-2
	Basic Configuration	4-2
	Advanced Configuration	4-2
	Antenna	4-3
	Tank Geometry	4-5
	Advanced Tank Geometry Configuration	4-6
	Analog Output	4-7
	Process Conditions	4-9
	Temperature Measurement	4-9
	Volume Calculation	4-10
	Advanced Functions	4-11
	Disturbance Echo Handling	4-11
	Bottom Echo Handling	4-14
	Full Tank Handling	4-15
	Empty Tank Handling	4-15
	Surface Tracking	4-16
	Filtering	4-18
SECTION 5		
HART Configuration		
	Safety Messages	5-1
	Overview	5-1
	PC Configuration Software Radar Master	5-2
	Installation	5-2
	Main Configuration Icons	5-4
	Hand-Held Communicator	5-7
	HART Fast Keys	5-9
	Setting the Loop to Manual	5-9
	Connections and Hardware	5-9
	Using a Hand Held Communicator	5-10
	Level Configuration Example	5-10
SECTION 6		
FOUNDATION Fieldbus		
Configuration		
	Introduction	6-1
	Overview	6-2
	Foundation Fieldbus Function Blocks	6-2
	Assigning Device Tag and Node Address	6-3
	Configure Transmitter using Delta V	6-3
	Configure the Parameters	6-4
	Configure the AI Block	6-10
	Application Examples	6-13
	Application Example: Radar Level Transmitter, Level Value	6-13
	Application Example:	

	Radar Level Transmitter, Level value in percent (%)	6-14
	Application Example:	
	Radar Level Transmitter used to Display Volume	6-15
	Configuration Using the Sensor Bus Port	6-16
	Electrical Connection	6-16
	Switching to Sensor Bus Mode	6-18
SECTION 7		
2210 Display Unit	Safety Messages	7-1
Configuration	Rosemount 2210 Display Unit	7-2
	Operation	7-3
	Viewing Level Data	7-6
	Display Setup	7-7
	Installing a Rosemount 5600 Radar Level Transmitter	7-8
SECTION 8		
Maintenance and	Overview	8-1
Troubleshooting	Safety Messages	8-1
	Warnings	8-1
	HART Maintenance and Troubleshooting	8-2
	Troubleshooting Table	8-2
	Service Using the Rosemount 2210 Display Unit	8-2
	Field Upgrades	8-2
	Connection via Sensor Bus Port	8-3
	Fieldbus Maintenance and Troubleshooting	8-4
	Configure Transmitter	8-4
	Service Method	8-4
	Calibration Distance Configuration	8-4
	Master Reset Method (Resource Block)	8-4
	Write Protection (Resource Block)	8-4
	Block Instantiation	8-6
	Troubleshooting Table	8-6
	Field Upgrades	8-7
	Resource Block	8-8
	Transducer Block	8-9
	Analog Input (AI) Function Block	8-9
APPENDIX A		
Reference Data	Specifications	A-1
	General	A-1
	Measuring Performance	A-1
	Display/Configuration	A-2
	Electric	A-3
	Analog Output Characteristics	A-3
	Fieldbus Output Characteristics	A-4
	2210 Display Unit Output Characteristics	A-5
	Mechanical	A-6
	Environment	A-7
	Dimensional Drawings	A-8
	Ordering Information	A-13
	Accessories	A-19
APPENDIX B		
Product Certifications	Approved Manufacturing Locations	B-1
	European Union Directive Information	B-1
	5600 Series Radar Level Transmitter	B-1

Rosemount 5600 Series

	2210 Display Unit	B-4
	ATEX Directive (94/9/EC)	B-5
	Ordinary Location Certification for Factory Mutual	B-5
	Canadian Registration Number (CRN)	B-5
	Hazardous Locations Certifications	B-6
	ATEX Approval Drawings	B-9
	CSA Approval Drawings	B-13
APPENDIX C		
Level Transducer Block	Overview	C-1
	Parameters and Descriptions	C-2
	Diagnostics Device Errors	C-6
	Supported Units	C-7
	Unit codes	C-7
	Methods	C-7
APPENDIX D		
Resource Block	Overview	D-1
	Parameters and Descriptions	D-2
APPENDIX E		
Register Transducer Block	Overview	E-1
	Register Access Transducer Block Parameters	E-1

Section 1 Introduction

Safety Messages	page 1-1
Overview	page 1-2
Specific FCC Requirements (USA only)	page 1-6
Unpacking your 5600 Transmitter	page 1-8
Service Support	page 1-9

SAFETY MESSAGES

Procedures and instructions in this manual may require special precautions to ensure the safety of the personnel performing the operations. Information that raises potential safety issues is indicated by a warning symbol (⚠). Refer to the safety messages listed at the beginning of each section before performing an operation preceded by this symbol.

⚠ WARNING

Explosions could result in death or serious injury:

Verify that the operating environment of the transmitter is consistent with the appropriate hazardous locations certifications.

Before connecting a HART-based communicator in an explosive atmosphere, make sure the instruments in the loop are installed in accordance with intrinsically safe or non-incendive field wiring practices.

⚠ WARNING

Failure to follow safe installation and servicing guidelines could result in death or serious injury:

Make sure only qualified personnel perform these procedures.

Use the equipment only as specified in this manual. Failure to do so may impair the protection provided by the equipment.

Do not perform any service other than those contained in this manual unless you are qualified.

⚠ WARNING

This product is an electrical apparatus and must be installed in the hazardous area in accordance with the requirements of the EC Type Examination Certificate.

The installation and maintenance must be carried out in accordance with all appropriate international, national and local standard codes of practice and site regulations for intrinsically safe apparatus and in accordance with the instructions contained within this manual. Access to the circuitry must not be made during operation.

OVERVIEW

This manual provides information about mechanical and electrical installation of the 5600 Series Radar Level Transmitter. It also describes how to start up and configure the transmitter. The main purpose of the book is to act as guide to installing and operating the 5600 Series Radar Level Transmitter. It is not intended to cover service tasks such as changing circuit boards or internal software.

Section 2: Mechanical Installation

- Mechanical installation instructions

Section 3: Electrical Installation

- Electrical installation instructions

Section 4: Operation

- Operation

Section 5: HART Configuration

- Commissioning
- Software functions
- Configuration parameters
- Online variables

Section 6: FOUNDATION Fieldbus Configuration

- Commissioning with Delta V
- Software functions
- Configuration parameters
- Online variables

Section 7: 2210 Display Unit Configuration

- Commissioning

Section 8: Maintenance and Troubleshooting

- Troubleshooting techniques for the most common operating problems for HART and FOUNDATION fieldbus protocol only.

Appendix A: Reference Data

- Specifications
- Dimensional Drawings
- Ordering information for HART and FOUNDATION fieldbus protocols

Appendix B: Product Certifications

- Intrinsic safety approval information
- European ATEX directive information
- Approval drawings for HART and fieldbus protocols

Appendix C: Level Transducer Block

- Supplies Level Transducer Block data

Appendix D: Resource Block

- Contains information relating to the operation of the resource block.

Appendix E: Register Transducer Block

- Contains information relating to the operation of the register transducer block.

The 5600 Series Radar Level Transmitter is a powerful radar level transmitter suitable for non-contact level measurements in process tanks, storage tanks, and other types of tanks. It is designed for easy installation and maintenance free operation.

Together with the Rosemount Radar Master Configuration Tool you are able, in an easy and user-friendly way, to configure the 5600 transmitters. The Radar Master program is a Microsoft® Windows-based software package designed for the 5600 transmitters, and offers great assistance, from startup and commissioning to advanced service. It includes waveform plots, off-line configuration, logging, and an extensive on-line Help.

Figure 1-1. System Integration using the Hand-held Communicator

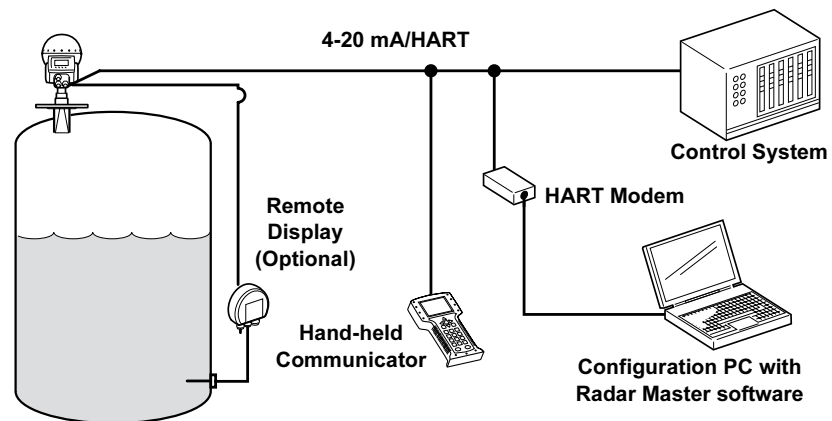

5600/PDS/BILD_1.EPS

Figure 1-2. System Integration using FOUNDATION fieldbus

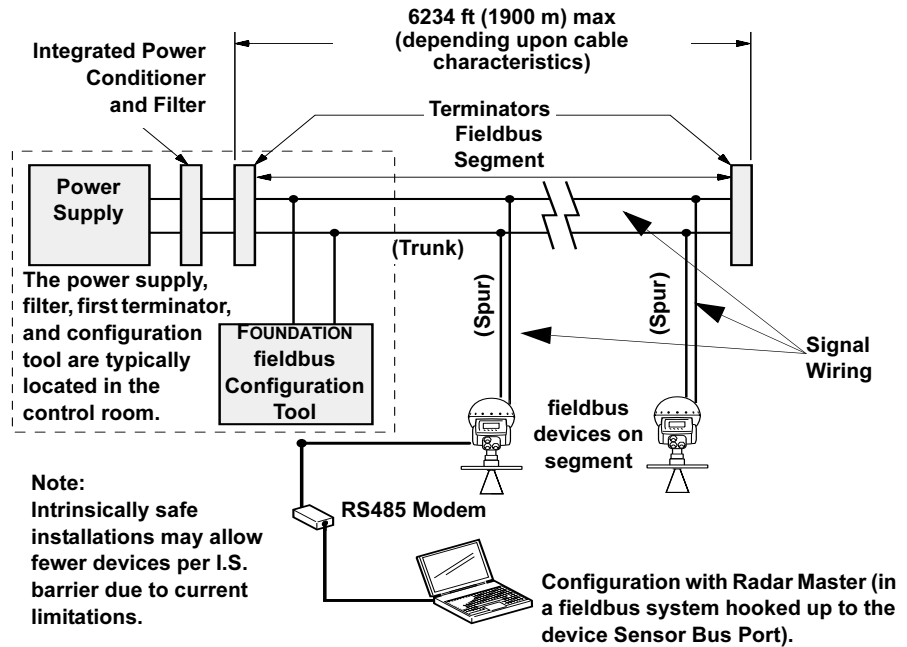

For stand-alone systems, or as a complement to a PC or a control system, you can monitor level data using one or two analog outputs depending on the particular hardware configuration.

As an option, your Rosemount 5600 Radar Level Transmitter can be equipped with an easy-to-use Rosemount 2210 Display Panel. It offers basically the same functionality as the Radar Master package. Four sturdy softkeys give you access to configuration routines, service functions, and level monitoring.

Measurement Principle

The level of the product in the tank is measured by radar signals transmitted from the antenna at the tank top. After the radar signal is reflected by the product surface the echo is picked up by the antenna. As the signal is varying in frequency the echo has a slightly different frequency compared to the signal transmitted at that moment. The difference in frequency is proportional to the distance to the product surface, and can be accurately calculated. This method is called FMCW (Frequency Modulated Continuous Wave) and is used in all high performance radar transmitters.

Figure 1-3. Frequency Modulated Continuous Wave

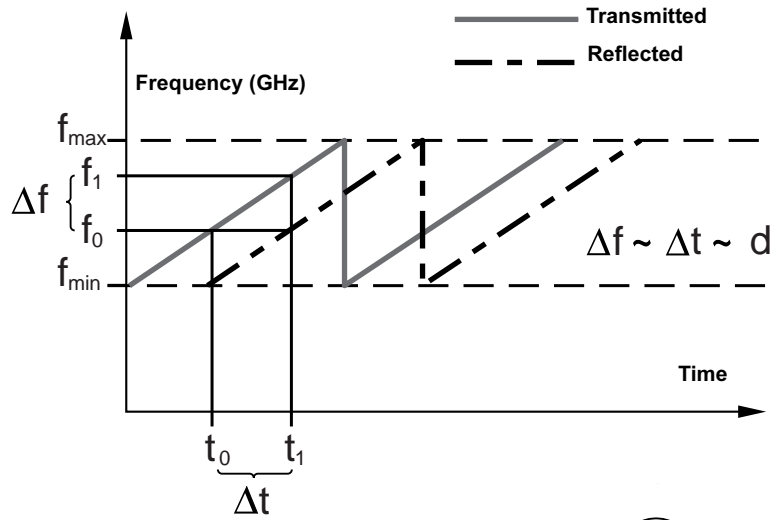

The FMCW method is based on a radar sweep with continuous changes in frequency.

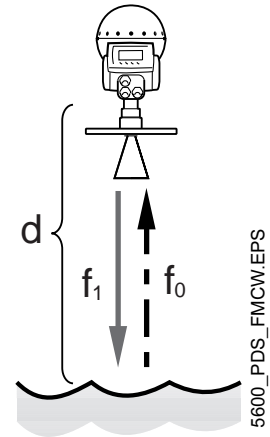

Rosemount 5600 Series

The 5600 Series Radar Level Transmitter sends a microwave signal with a continuously varying frequency towards the product surface. When the reflected signal returns to the antenna, it is mixed with the outgoing signal.

Since the transmitter continuously changes the frequency of the transmitted signal, there will be a difference in frequency between the transmitted and the reflected signals.

The transmitter mixes the two signals, resulting in a low frequency signal which is proportional to the distance to the product surface. This signal can be measured very accurately allowing fast, reliable, and accurate level measurements.

The 5600 Series Radar Level Transmitter uses micro frequency to reduce sensitivity to vapor, foam, and contamination of the antenna, and keeps the radar beam narrow in order to minimize influence from walls and disturbing objects.

The 5600 Series Radar Level Transmitter uses Fast Fourier Transformation (FFT), which is a well established signal processing technique, to obtain a frequency spectrum of all echoes in the tank. From this frequency spectrum the surface level is extracted. In combination with the echofixer, FFT allows measurements in tanks with agitators, mixers and other disturbing objects. The echofixer provides a technique to adapt measurements to various situations, by using information from previous measurements.

SPECIFIC FCC REQUIREMENTS (USA ONLY)

This device complies with part 15 of the FCC Rules. Operation is subject to the following two conditions: (1) This device may not cause harmful interference, and (2) this device must accept any interference received, including interference that may cause undesired operation.

The Rosemount 5600 generates and uses radio frequency energy. If it is not installed and used properly (in strict accordance with the manufacturer's instructions) it may violate FCC regulations on radio frequency emission.

Installation on non-metallic tanks, tanks with open manholes, external-floating-roof tanks without stillpipes etc. are not covered by this certificate, and require a Part 90 site-license. If you have an installation like this, contact your local Emerson Process Management representative for help with the necessary license application.

Measuring Range

The diagrams below show how the measuring range is influenced by the antenna type, dielectric constant of the liquid (ϵ_r) and the process conditions. For optimum performance the maximum measuring distance should be kept within the range indicated with darker color in the diagrams. Values are valid for free propagation measurement without still-pipes (bridles).

For liquids with ϵ_r that are smaller than 1.9 such as liquefied gases, an 8 inch or bigger diameter antenna is recommended if measurement is done with free propagation. In this case the measuring range in calm surface tanks is in typical cases 50 ft. (15 m).

To increase the measuring range further in turbulent tanks, a still-pipe can be used. For still-pipe mounted 5600 transmitters the typical measuring range is 115-160 ft. (35-50 m) in turbulent tanks with liquids having ϵ_r less than 1.9.

Table 1-1. Categories of liquids

a	Oil, gasoline and other hydrocarbons, petrochemicals (dielectric constant, $\epsilon_r=1.9-4.0$)
b	Alcohols, concentrated acids, organic solvents, oil/water mixtures and acetone ($\epsilon_r=4.0-10$)
c	Conductive liquids, e.g. water based solutions, dilute acids and alkalis ($\epsilon_r > 10$)

Figure 1-4. Applications with calm product surface⁽¹⁾

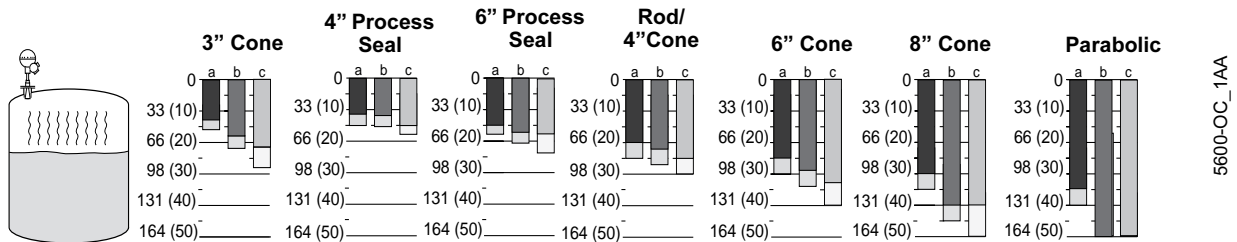

Figure 1-5. Applications where the product is gently stirred, causing minor turbulence⁽¹⁾

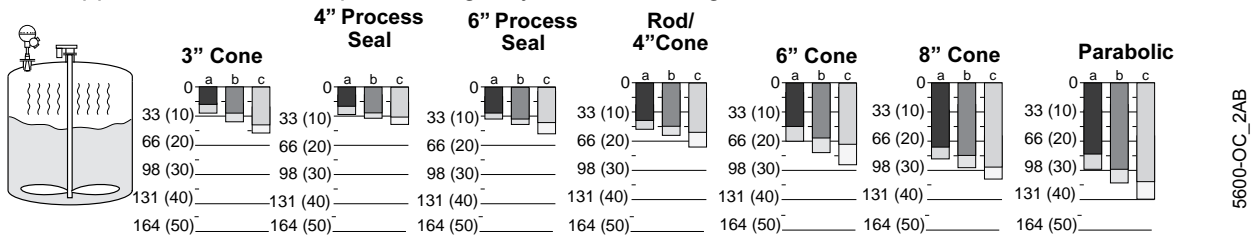
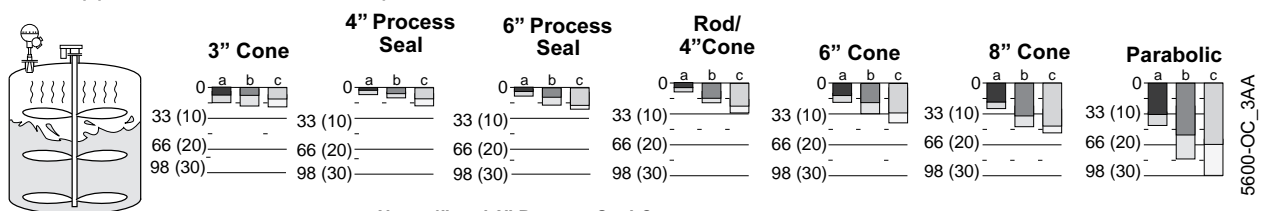

Figure 1-6. Applications with turbulent product surface conditions⁽¹⁾



Note: 4" and 6" Process Seal Cones are not recommended for turbulent conditions

(1) Measuring range in ft. (m).

Minimum Measuring Distance

The minimum distance the radar can measure depends on the antenna selected. Typically the level can come as close as 0.79-in. (20 mm) from the antenna tip, before the software disregards the signal. Being this close to the antenna may however reduce the measurement accuracy. Table 2-1 on page 2-3 includes the value Hold Off Distance, which is the default setting for this minimum distance. It can not be decreased, only increased if needed.

Measuring Close to Tank Bottom

When measuring products with low dielectric constants, i.e. DC range 1.4 - 2.5, some of the radar energy will go thru the product. This could lead to that the radar will see the Flat Tank Bottom, even though there is a small amount of product covering the bottom of the tank. This could reduce the accuracy of the measurement at these lower product levels. This could occur at product levels of 4-6 inch (100-150 mm) or lower, but depends on the product as well as the tank bottom type. There are special software settings that could improve this situation, or alternatively mechanical changes could be implemented to minimize the influence from the bottom of the tank.

UNPACKING YOUR 5600 TRANSMITTER

Verify that you have received:

- 1 box with the transmitter head. This box also includes a Hook spanner (used to open the terminal compartments), Reference manual (00809-0100-4024), Rosemount Radar Master CD-Rom (0822-0100-4757), and a Quick Installation Guide.
- 1 box with the antenna. This box contains the complete antenna assembly, including the Waveguide Tube (see page 2-6) which is to be inserted in the transmitter head foot.

NOTE

If you ordered flanges, the flanges are typically stored at the bottom of the bigger wooden crate that the transmitter is delivered in. They are held in place with bolts and nuts.

Rosemount 5600 Series

SERVICE SUPPORT

If you have reason to believe that your Rosemount 5600 Radar Level Transmitter may need to be returned for service, contact the appropriate representative.

Within USA:

Please contact a Level Applications Support Specialist at Rosemount Customer Central (1-800-999-9307). They will help you determine the best course of action, and may transfer you to either an Order Administrator or to the Rosemount North American Response Center (NARC) to arrange for the return of your transmitter for service or repair.

Outside USA:

For Service Support outside the United States, please contact your nearest Rosemount Representative.

NOTE

Most radar problems encountered in the field are applications-related and can best be dealt with while the transmitter is installed.

The representative will assist you with any needed information or materials.

The representative will ask for the following information:

- Product model
- Serial numbers
- The last process material to which the product was exposed

The representative will provide:

- A Return Material Authorization (RMA) number
- Instructions and procedures that are necessary to return goods that were exposed to hazardous substances

Spare Parts

Any substitution of non-recognized spare parts may jeopardize safety. Repair, e.g. substitution of components etc., may also jeopardize safety and is under no circumstances allowed.

Rosemount 5600 Series

Reference Manual
00809-0100-4024, Rev BA
September 2005

Section 2 Mechanical Installation

Safety Messages	page 2-1
Introduction	page 2-2
General Installation Requirements	page 2-2
Wave Guide Tubes	page 2-6
Mounting the Rod Antenna, Flanged Version	page 2-7
Mounting the Rod Antenna, Threaded Version	page 2-11
Mounting the Cone Antenna - PTFE sealing	page 2-14
Mounting the Cone Antenna - Quartz sealing	page 2-17
Mounting the Process Seal Antenna	page 2-22
Mounting the Parabolic Antenna	page 2-31
Mounting the Extended Cone Antenna	page 2-37
Mounting the Cone Antenna with Flushing Connections	page 2-43

SAFETY MESSAGES

Procedures and instructions in this manual may require special precautions to ensure the safety of the personnel performing the operations. Information that raises potential safety issues is indicated by a warning symbol (⚠). Refer to the safety messages listed at the beginning of each section before performing an operation preceded by this symbol.

⚠ WARNING

Explosions could result in death or serious injury:

Verify that the operating environment of the transmitter is consistent with the appropriate hazardous locations certifications.

Before connecting a HART-based communicator in an explosive atmosphere, make sure the instruments in the loop are installed in accordance with intrinsically safe or non-incendive field wiring practices.

⚠ WARNING

This product is an electrical apparatus and must be installed in the hazardous area in accordance with the requirements of the EC Type Examination Certificate.

The installation and maintenance must be carried out in accordance with all appropriate international, national and local standard codes of practice and site regulations for intrinsically safe apparatus and in accordance with the instructions contained within this manual. Access to the circuitry must not be made during operation.

⚠ WARNING

Failure to follow safe installation and servicing guidelines could result in death or serious injury:

Make sure only qualified personnel perform these procedures.

Use the equipment only as specified in this manual. Failure to do so may impair the protection provided by the equipment.

Do not perform any service other than those contained in this manual unless you are qualified.

The quartz seal is not suitable for use in environments where there is a risk for variations or other mechanical impacts.

For quartz seal, mechanical shocks may permanently damage the seal. A damaged tank seal must be replaced. Replacement must be done when the tank is unpressurized.

The customer must always make sure that exposed material of antenna and tank seal is compatible with the tank content, e.g. the quartz seal is not suitable for use with Hydrofluoric acid (HF).

A damaged quartz tank seal will typically cause one or many disturbance echoes which will be seen in a tank spectrum plot during gauge configuration.

INTRODUCTION

This section describes the mechanical installation. Start by reading the General Installation Requirements for your antenna. This includes Nozzle and Free Space Requirements. The last part of this section includes mounting instructions for all antenna types, including special requirements for still pipe/bridle installations and applications.

Tools

The following set of tools are needed for installation of a 5600 Series Radar Level Transmitter:

- Screw driver.
- Adjustable wrench.
- Allen key.
- Circlip plier (snap ring plier).
- Hook spanner (comes delivered with the transmitter).

GENERAL INSTALLATION REQUIREMENTS

Position the transmitter in a way that allows the microwaves to propagate without disturbance from the tank wall. In order to achieve optimum performance you should consider the following recommendations:

- Try to avoid obstacles in the radar beam.
- Mount the transmitter away from pipe inlets which cause turbulent conditions.
- Choose as large antenna as possible to ensure maximum antenna gain.
- For best measurement performance it is recommended that the antenna tip ends outside the nozzle, see Figure 2-2.

Customer Supplied Flanges

The simple design of cone and rod antennas tank connection allows the use of customer supplied flanges. If a hole is drilled in a standard blind flange the pressure performance may be reduced. In such a case the flange should be marked with new rating for Maximum Allowed Working Pressure (MAWP).

Nozzle Requirements

In order to allow the microwaves to propagate undisturbed, the nozzle dimensions should be kept within the specified limits for the different antennas.

Figure 2-1. Nozzle Requirements, see Table 2-1

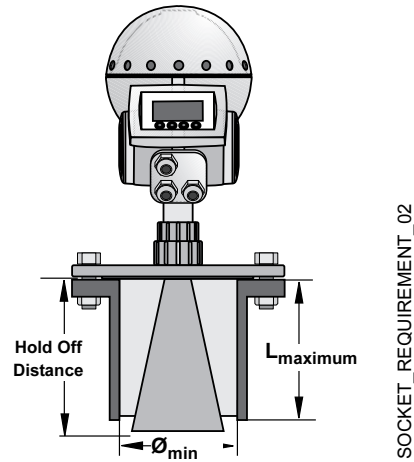

SOCKET_REQUIREMENT_02

Table 2-1. Nozzle Requirements in inches (millimeters)

Antenna	L _{recommended}	Diam _{min}	L _{maximum}	Hold Off Distance
Rod100	3.9 (100) or less	1.6 (43)	3.9 (100)	23.6 (600)
Rod250	9.8 (250) or less	1.6 (43)	9.8 (250)	30.7 (780)
Cone 3 in.	3.7 (95) or less	2.9 (75)	9.6 (245)	4.7 (120)
Cone 4 in.	5.9 (150) or less	3.8 (98)	11.8 (300)	6.7 (170)
Cone 6 in.	10.2 (260) or less	5.7 (146)	16.1 (410)	11.0 (280)
Cone 8 in.	14.6 (370) or less	7.6 (194)	20.6 (525)	15.8 (400)
Parabolic	6.3 (160) or less	19.7 (500)	23.6 (600)	7.9 (200)
Process Seal 4 in.	11.8 (300) or less	3.9 (100)	11.8 (300)	7.9 (200)
Process Seal 6 in.	11.8 (300) or less	5.9 (150)	11.8 (300)	7.9 (200)
Extended Cone 3 in.	19.5 (495) or less	3.0 (75)	19.5 (495)	20.5 (520)
Extended Cone 4 in.	19.5 (495) or less	3.9 (98)	19.5 (495)	20.5 (520)
Extended Cone 6 in.	19.5 (495) or less	5.8 (146)	19.5 (495)	20.5 (520)
Flushing Cone 4 in.	5.9 (150) or less	3.9 (98)	11.8 (300)	6.7 (170)
Flushing Cone 6 in.	10.2 (260) or less	5.8 (146)	16.1 (410)	11.0 (280)
Flushing Cone 8 in.	14.6 (370) or less	7.6 (194)	20.7 (525)	15.8 (400)

NOTE

For Parabolic Antennas mounted in solid applications, minimize the L Distance to allow the Parabolic Antenna to reach into the tank. See **Measuring Solids with a Rosemount 5600 Non-contacting Radar** (part number 00830-0800-4024).

Figure 2-2. Antenna Tip Outside Nozzle to get the Best Measurement Performance

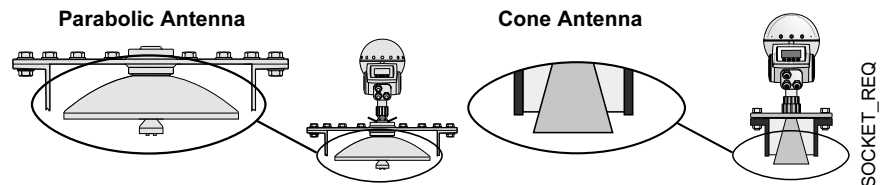

Free Space Requirements

Figure 2-3. Free Space Requirements, see Table 2-2

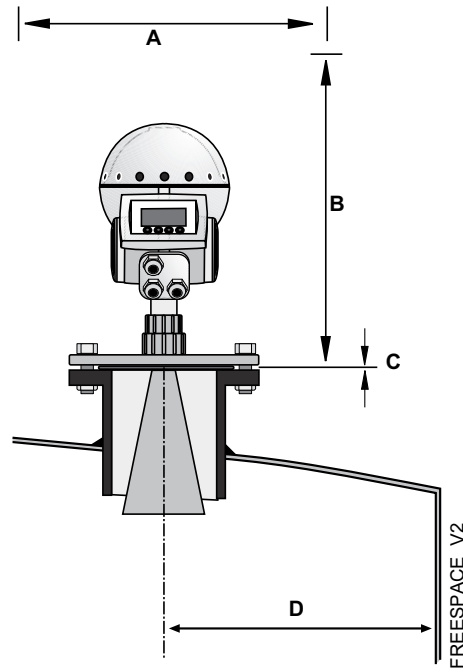

Table 2-2. Free Space Requirements

A. Service Space Width		Distance in. (mm)
All antennas		22 (550)
B. Service Space Height		
Antenna	Distance in. (mm)	
Rod	27 (700)	
Cone, Extended Cone, Flushing Cone	25 (650)	
Process Seal	31 (800)	
Parabolic	27 (700)	
C. Inclination		
Antenna	Maximum Angle	
Rod	3°	
Cone	1°	
Process Seal	3°	
Parabolic	3°	
D. Minimum distance to tank wall ⁽¹⁾		
Antenna	Distance in. (mm)	
Rod	24 (600)	
Cone	24 (600)	
Process Seal	24 (600)	
Parabolic	24 (600)	

(1) Mounting closer to the tank wall may be allowed if reduced accuracy is accepted.

Beam Width

Figure 2-4. Beam width angle, see Table 2-3

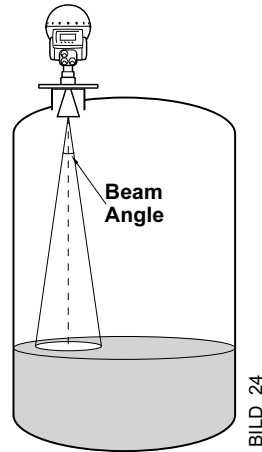

Table 2-3. Beam width angle

Antenna	Beam Width
Cone 3 in.	25°
Rod/Cone 4 in./ Process Seal 4 in.	21°
Cone 6 in./ Process Seal 6 in.	18°
Cone 8 in.	15°
Parabolic	10°

Figure 2-5. Beam width distance, see Table 2-4

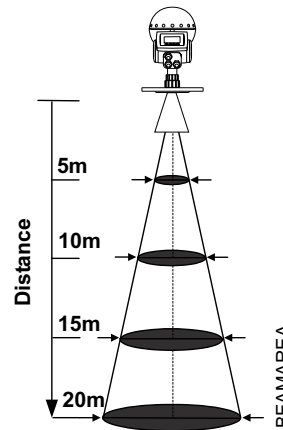

Table 2-4. Beam width distance

Antenna	Diameter of radiated area at different distances from flange, ft. (m)			
	16 ft (5 m)	33 ft (10 m)	49 ft (15 m)	66 ft (20 m)
Cone 3 in.	7.2 (2.2)	14 (4.4)	22 (6.7)	29 (8.9)
Rod/Cone 4 in./ Process Seal 4 in.	6.2 (1.9)	12 (3.7)	18 (5.6)	24 (7.4)
Cone 6 in./ Process Seal 6 in.	5.2 (1.6)	10 (3.1)	15 (4.7)	21 (6.3)
Cone 8 in.	3.3 (1.0)	7.9 (2.4)	13 (3.9)	17 (5.2)
Parabolic	3.0 (0.9)	5.6 (1.7)	8.5 (2.6)	11 (3.5)

Special Antennas and Space Requirements Reference

Pipe Installation

See page 2-40 and page 2-25.

Extended Cone Installation

See page 2-40 and page 2-37.

WAVE GUIDE TUBES

NOTE

The Waveguide Tubes are parts of the antenna kits.

Cone and Rod Antenna

- For model codes 1xx, 2xx, 7xx, and 9xx (with PTFE Seal for Cone)
- Distinguishing features:
 - a. Length: 1.57-in. (40 mm)

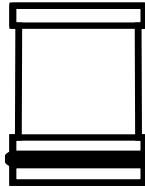

Process Seal

- For model codes 34S and 36S.
- Distinguishing features:
 - a. Length: 2.93-in. (74.5 mm)
 - b. O-ring on the inside

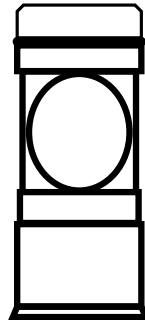

Parabolic

- For model codes 45S and 46S
- Distinguishing features:
 - a. Length: 2.93-in. (74.5 mm)
 - b. No o-ring on the inside

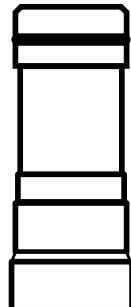

Cone Antenna with Quartz Seal

- Model code option Q (with Quartz Seal)
- Distinguishing features:
 - a. Complete assembly
 - b. No loose waveguide tube
- Not available as spare part. If spare part is required, order complete antenna.

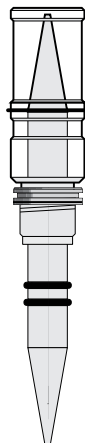

**MOUNTING THE ROD
ANTENNA, FLANGED
VERSION**

Figure 2-6. Rod Antenna
Dimensions, Flanged Version

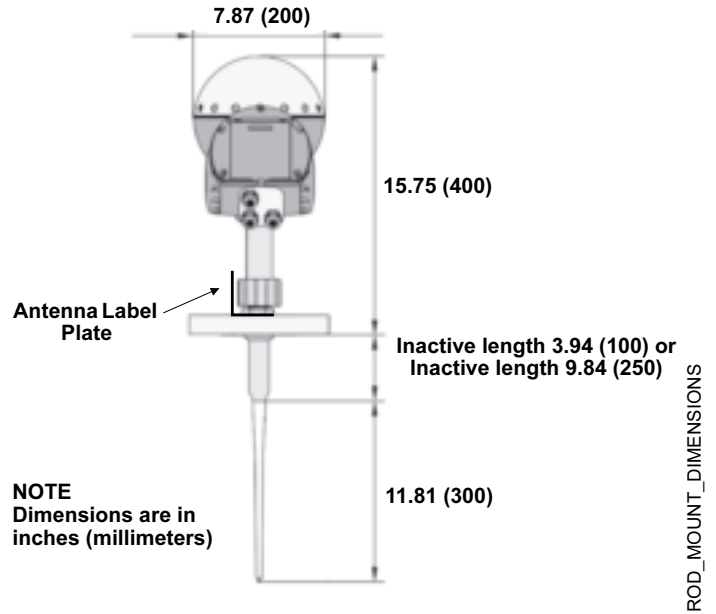

1. Mount the flange on top of the rod plate. Make sure the bottom side of the flange is flat and all parts are clean and dry.

Figure 2-7. Mount the flange



2. Secure the flange and label plate with the locking nut. Make sure the nut fits tightly to the flange.

Figure 2-8. Secure the flange with the locking nut

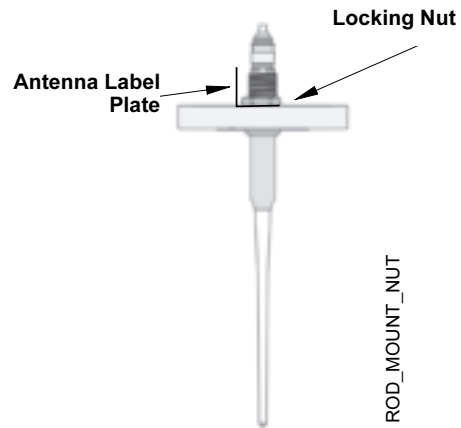

3. Mount the adapter on top of the sleeve.

Figure 2-9. Mounting the adapter

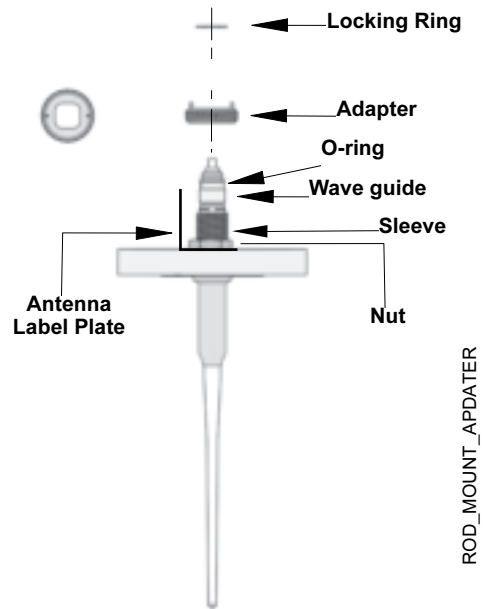

- Secure the adapter with the locking ring.

Figure 2-10. Use the locking ring to secure the adapter



- Carefully fit the flange and the rod antenna on the tank nozzle with an appropriate gasket in between. Tighten with screws and nuts.

Figure 2-11. Mount the flange and rod antenna on the nozzle

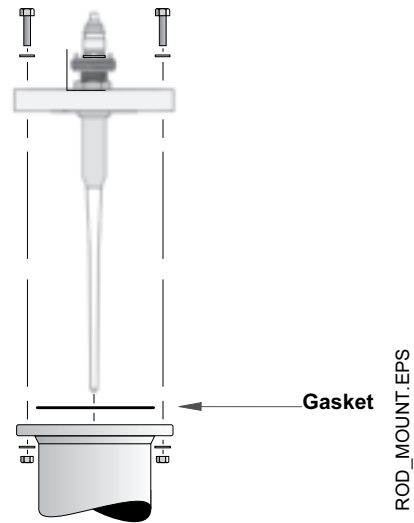

6. Insert the wave guide tube into the upper wave guide. Make sure the o-ring at the lower end of the wave guide tube is in place.

Figure 2-12. Mount the transmitter head

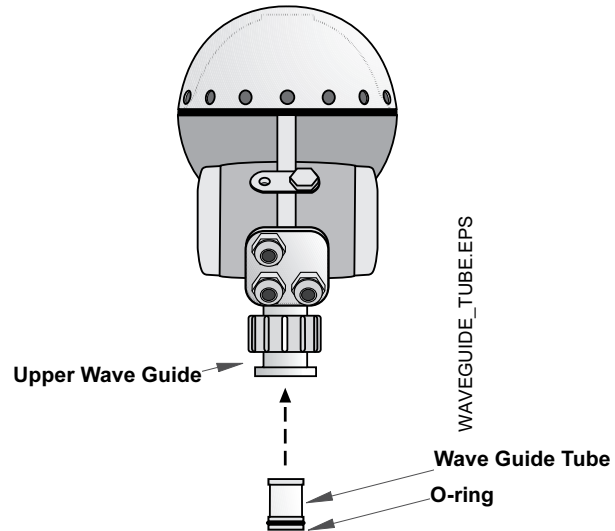

7. Place the protection sleeve on the flange. Mount the transmitter head and tighten the nut. Check that the guide pins on the adapter enter the corresponding grooves on the upper wave guide.

Figure 2-13. Completed mechanical installation

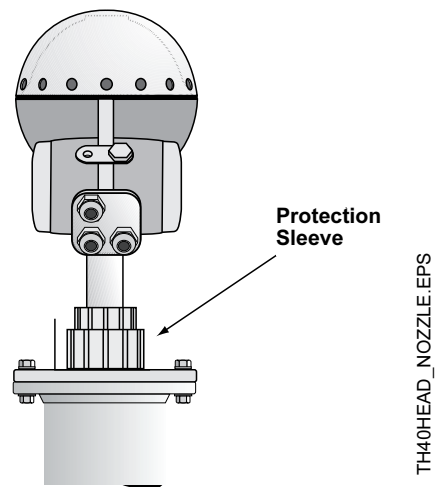

8. Proceed with the electrical installation.

**MOUNTING THE ROD
ANTENNA, THREADED
VERSION**

Figure 2-14. Rod Antenna
Dimensions, Threaded Version

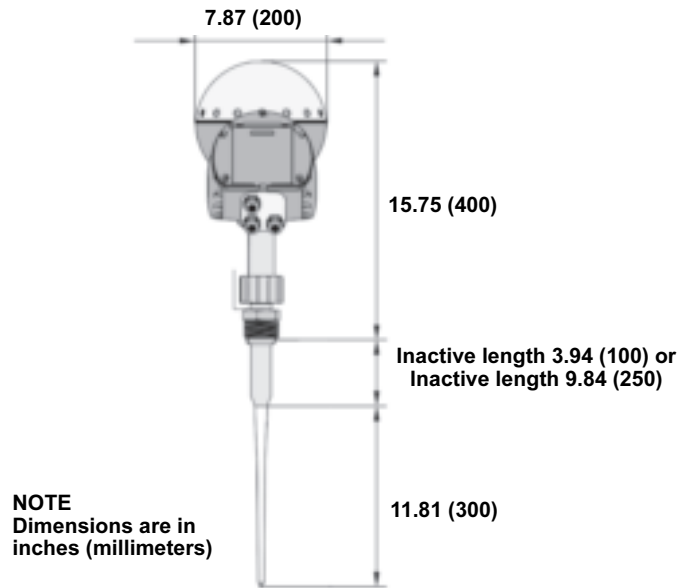

5600/9150074-921AA.EPS

1. Carefully fit the rod antenna into the threaded nozzle and screw it in place.

NOTE
For adapters with NPT threads, pressure-tight joints may require a sealant.

Figure 2-15. Mount the rod antenna

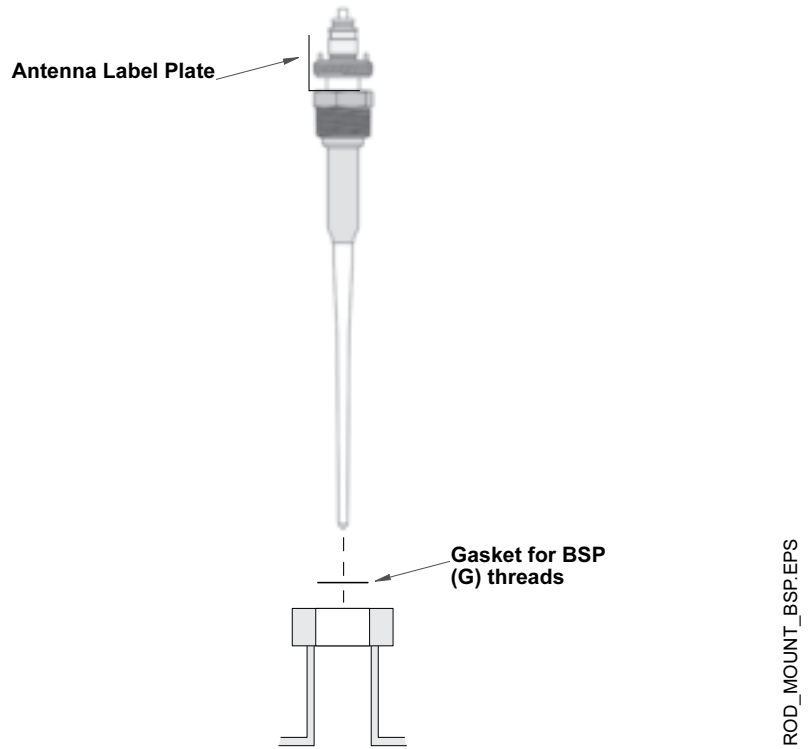

2. Insert the wave guide tube into the upper wave guide. Make sure the o-ring at the lower end of the wave guide tube is in place.

Figure 2-16. Mount the transmitter head

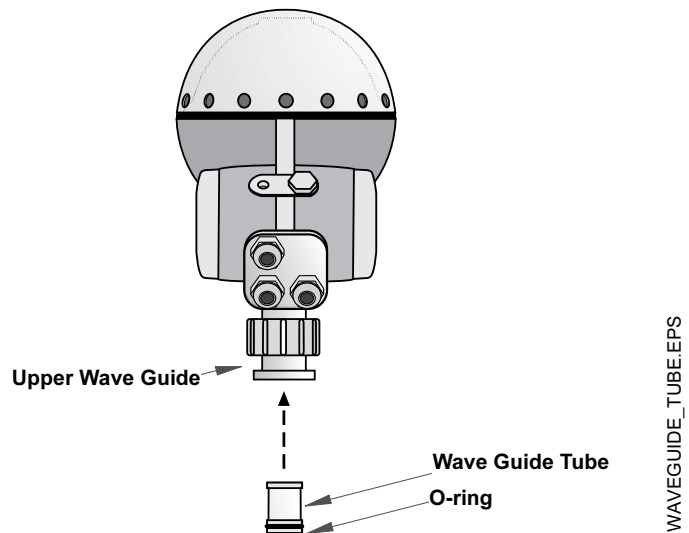

3. Place the protection sleeve on the flange. Mount the transmitter head and tighten the nut. Check that the guide pins on the adapter enter the corresponding grooves on the upper wave guide.

Figure 2-17. Completed mechanical installation

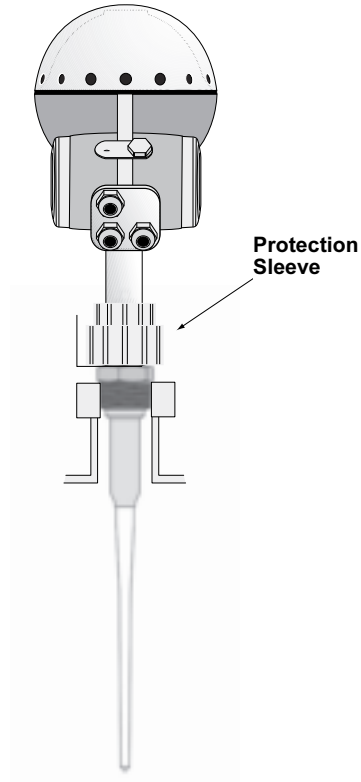

TH40HEAD_NOZZLE_BSPEPS

4. Proceed with the electrical installation.

Rosemount 5600 Series

MOUNTING THE CONE ANTENNA - PTFE SEALING

Figure 2-18. Cone Antenna
 Dimensions

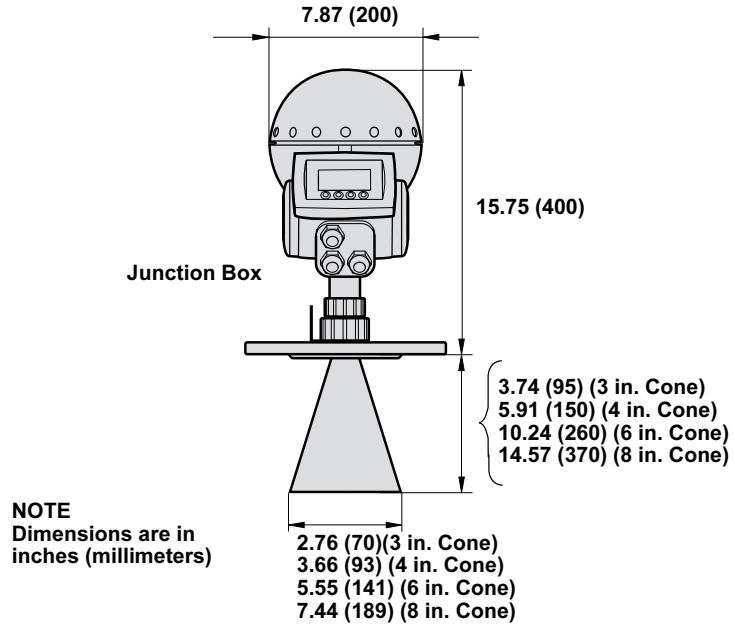

1. Remove locking ring and adapter from antenna.
2. Mount the flange on top of the cone plate. Make sure that the bottom side of the flange is flat and all parts are clean and dry.

Figure 2-19. Mount the flange

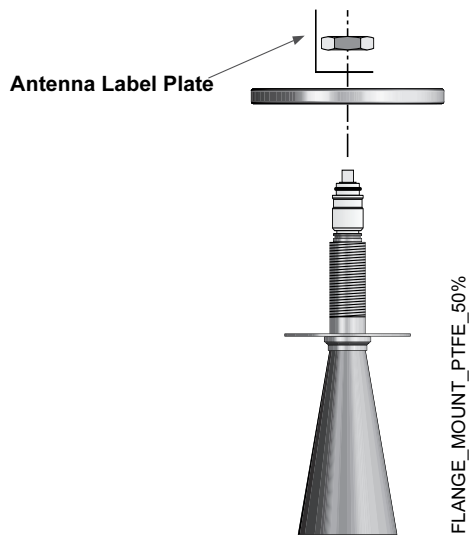

- Secure the flange with the locking nut.
Make sure that the nut fits tightly to the flange.

Figure 2-20. Secure the flange with the locking nut

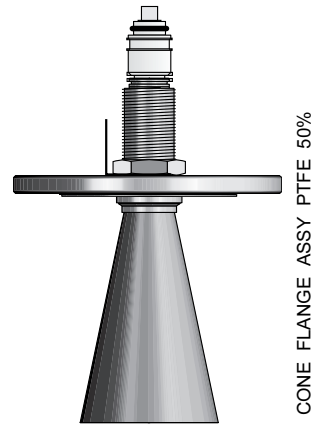

- Mount the adapter on top of the sleeve.

Figure 2-21. Mounting the adapter

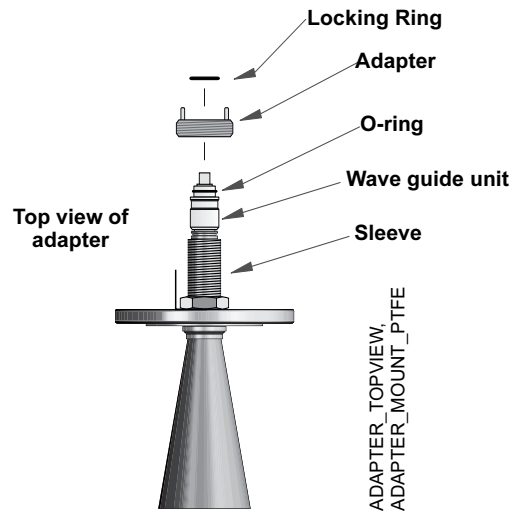

- Secure the adapter with the locking ring.

Figure 2-22. Use the locking ring to secure the adapter

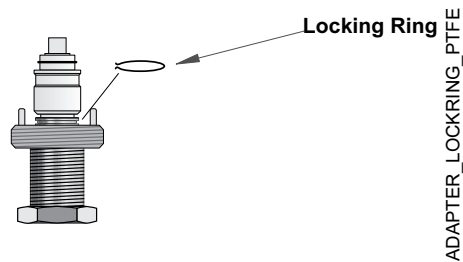

6. Carefully fit the flange and the cone antenna on the tank nozzle.
7. Tighten with screws and nuts.

Figure 2-23. Mount the flange and cone antenna on the nozzle

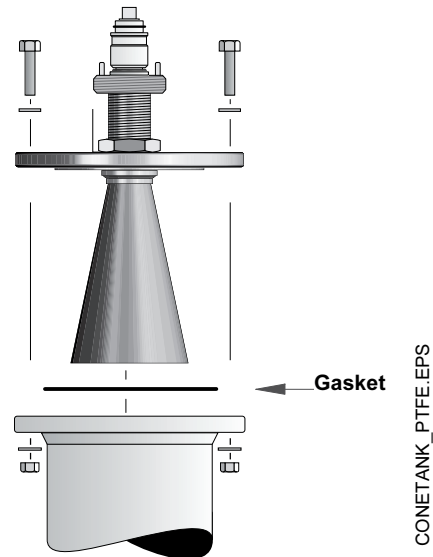

8. Insert the wave guide tube into the upper wave guide. Make sure the gasket at the lower end of the wave guide tube is in place.

Figure 2-24. Mount the transmitter head

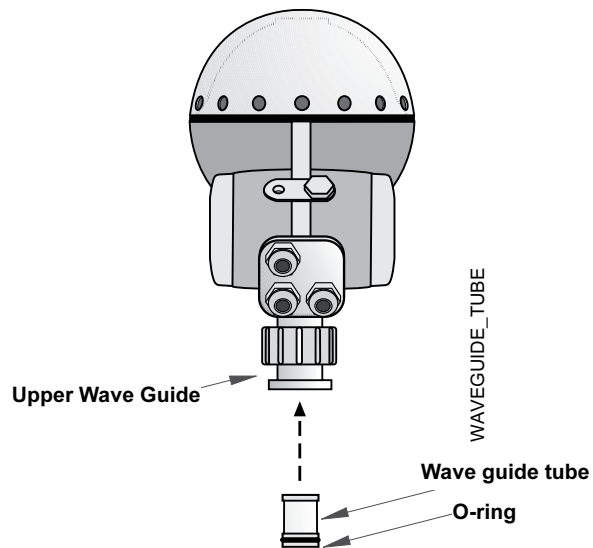

9. Place the protection sleeve on the flange. Mount the transmitter head and tighten the nut. Check that the guide pins on the adapter enter the corresponding grooves on the upper wave guide.

Figure 2-25. Completed mechanical installation

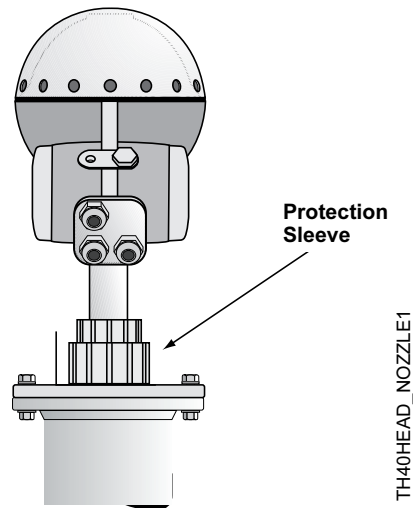

10. Proceed with the electrical installation.

MOUNTING THE CONE ANTENNA - QUARTZ SEALING

Figure 2-26. Cone Antenna Dimensions

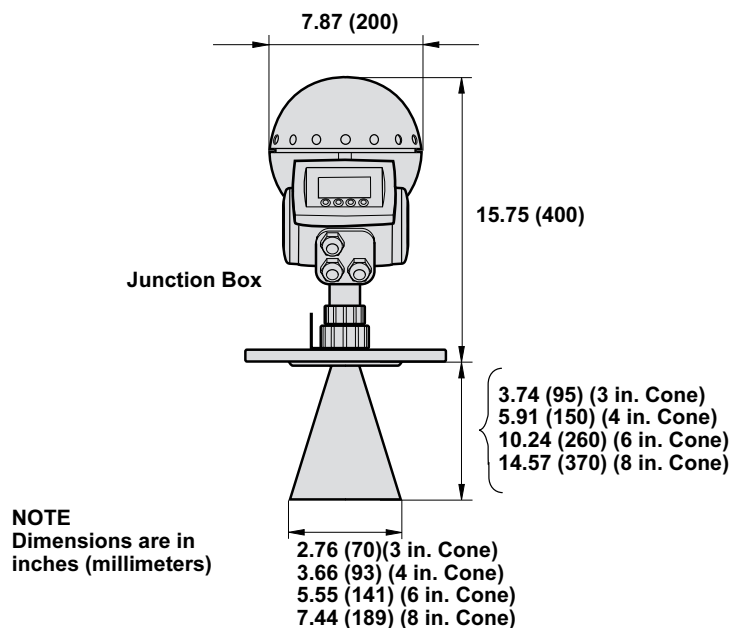

Antennas including tank seal of quartz material are suitable for high pressure applications.

NOTE

The quartz seal shall be protected against mechanical shocks or impacts. It is important to handle the antenna carefully in order to avoid any mechanical stresses such as bending or pressing the sealing.

1. Remove locking ring and adapter from antenna.
2. Mount the range on top of the cone plate. Make sure the bottom side of the flange is flat and all parts are clean and dry.

Figure 2-27. Mount the flange

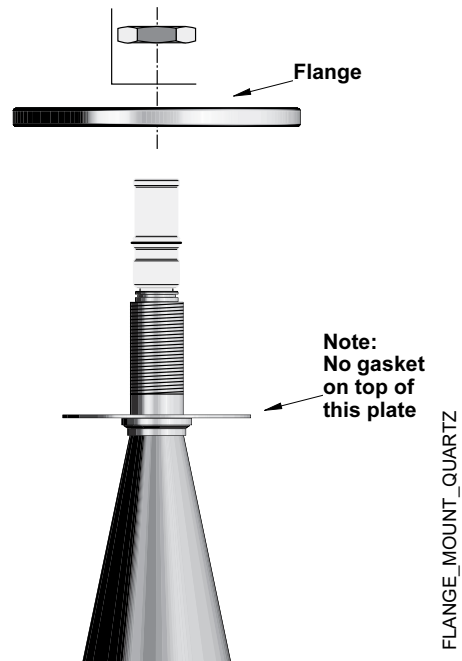

- Secure the flange and label plate with the locking nut using a spanner with key width 1.6-in. (41 mm). Make sure the locking nut fits tightly to the flange without any visible gap between the plate and the flange.

Figure 2-28. Secure the flange with the locking nut

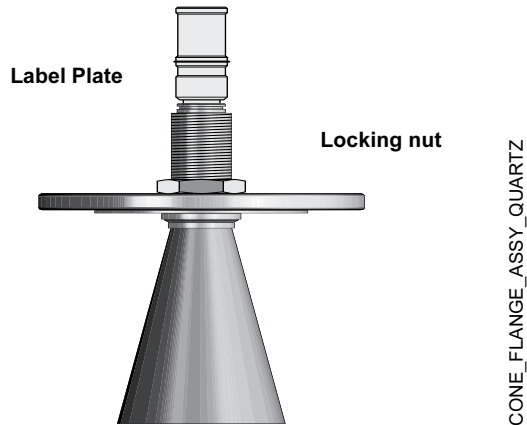

- Mount the adapter on top of the sleeve.

Figure 2-29. Mounting the adapter

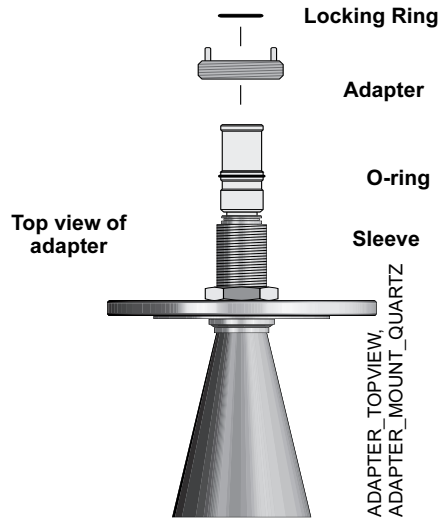

- Secure the adapter with the locking ring.

Figure 2-30. Use the locking ring to secure the adapter

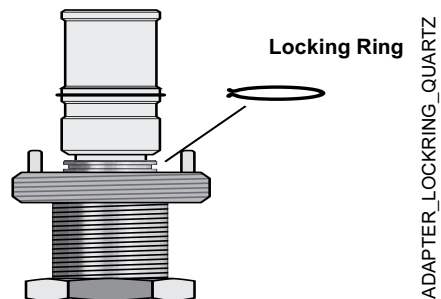

6. Fit the flange with the cone antenna on the horizontal tank flange. If the tank flange is not horizontal, the performance of the gauge may be negatively impacted.
7. Tighten with screws and nuts.

Figure 2-31. Mount the flange and cone antenna on the nozzle

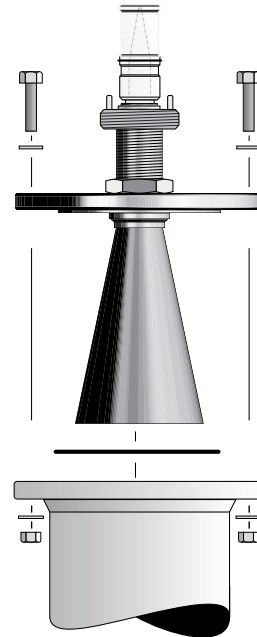

CONETANK_QUARTZ.EPS

8. Before mounting the transmitter head, visually verify that the quartz tank seal is undamaged and free from moisture and dirt.
9. Place the protection sleeve on the flange.
10. Mount the transmitter head on the adapter in one of the four possible positions.

Figure 2-32. Completed mechanical installation

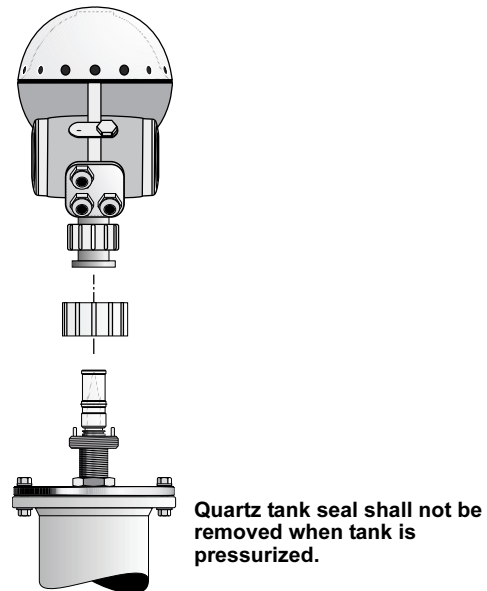

11. Check the guide pins on the adapter enter the corresponding grooves on the upper wave guide. Maximum allowed spacing is 0.2-in. (5 mm). Tighten the nut manually or with a wrench using approximately 20-50 Nm torque until it stops on the adapter. It is normal that the transmitter head can be rotated a fraction corresponding to the play between the guide pins and the grooves. This will not have any negative impact on the performance of the gauge.

Figure 2-33. Completed Installation

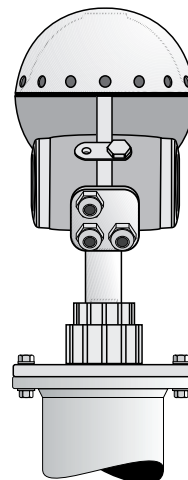

12. Proceed with the electrical installation.

Rosemount 5600 Series

MOUNTING THE PROCESS SEAL ANTENNA

Figure 2-34. Process Seal
Antenna Dimensions

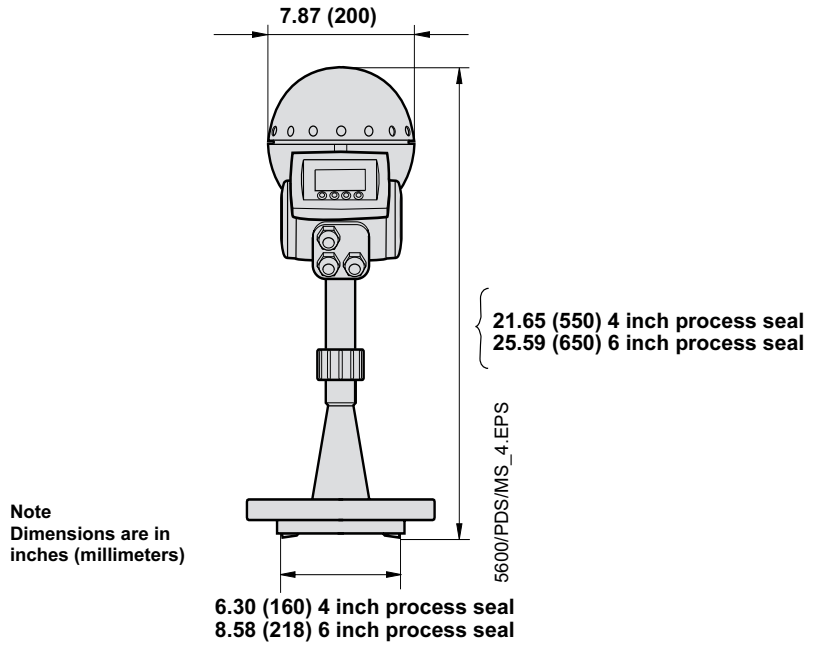

Preparations:

It is important that the tank flange surface is flat. The maximum deviation must be within the following specifications as illustrated:

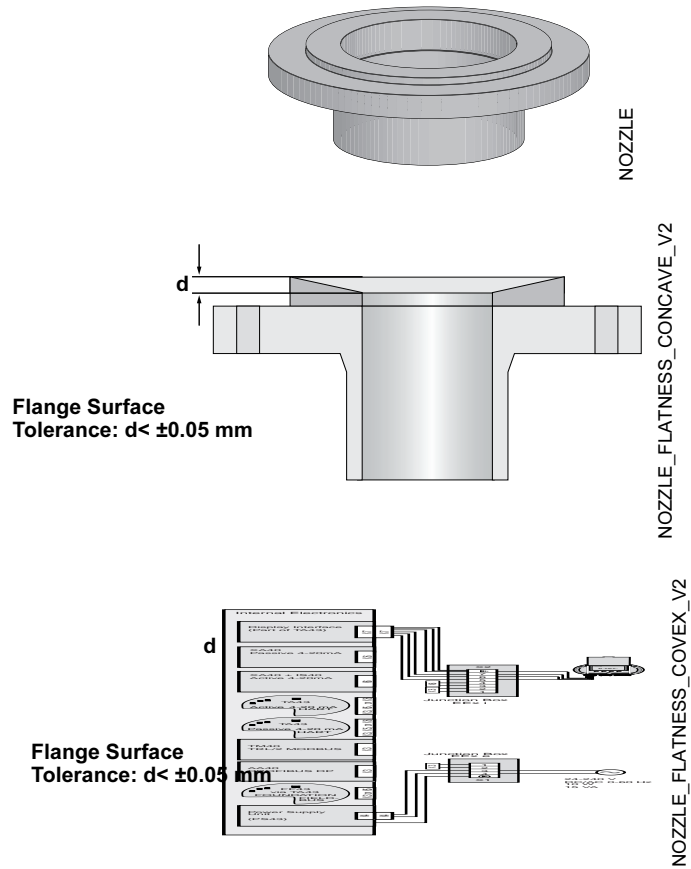

To mount the antenna do the following:

1. Place the teflon gasket supplied by Emerson Process Management on top of the nozzle and mount the antenna.

NOTE

The teflon gaskets are optimized for use with microwave emitting equipment. No other gaskets than Rosemount original may be used for Process Seal antennas.

- Put the loose flange on top of the antenna.

Figure 2-35. Put the flange on top of the antenna

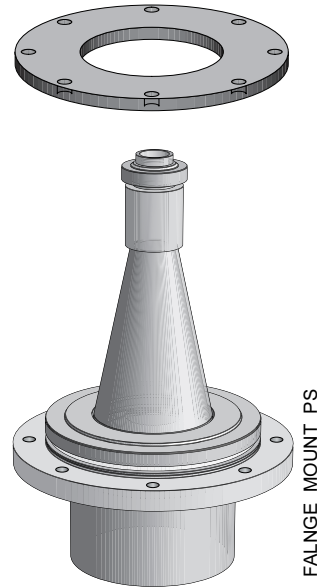

- Tighten the flange to the antenna by using screws and nuts. Use lubricating grease to minimize friction when the screws are tightened.

Figure 2-36. Tighten the flange

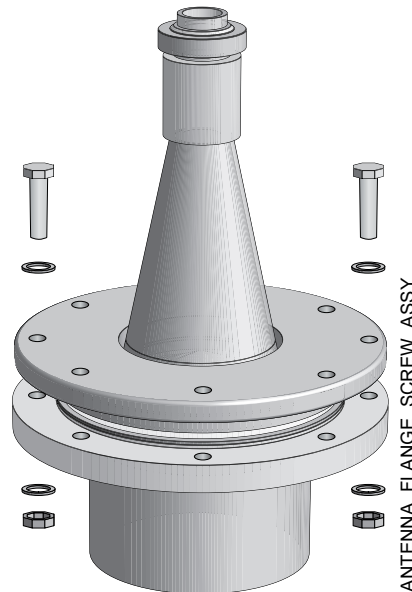

NOTE

Tighten the screws carefully to the recommended torque according to Table 2-5. Tighten opposite screws in pair.

4. Insert the wave guide tube into the upper wave guide.
 (See Figure 2-24 on page 2-16.)
5. Mount the transmitter head onto the adapter.
6. Tighten the nut and make sure that the transmitter head fits tightly to the antenna.

Torque

Tighten the flange screws to the following torque:

Table 2-5. Recommended Torque (Nm)

DIN Flange	PTFE	
	PN16	PN40
DN100	11	15
DN150	15	
ANSI Flange	150 Psi	300 Psi
4 in.	11	15
6 in.	15	10

MOUNTING THE CONE ANTENNA IN A STILL-PIPE/BRIDLE

NOTE

See Technical Note "Using Radar Transmitters in Stilling Wells and By-pass Cages" (part number 00830-2100-4024)

Installation Requirements for Cone Antenna in a Still-pipe/Bridle

The 5600 Series Radar Level Transmitter is suitable for measurements in still pipes and bridles. The high signal processing capacity allows measurements even when there are several pipe inlets, provided that the mechanical installation is done per the guidelines in this manual or related technical note.

Figure 2-37. Example of a Bridle mount (left) and a Still-pipe mount(right)

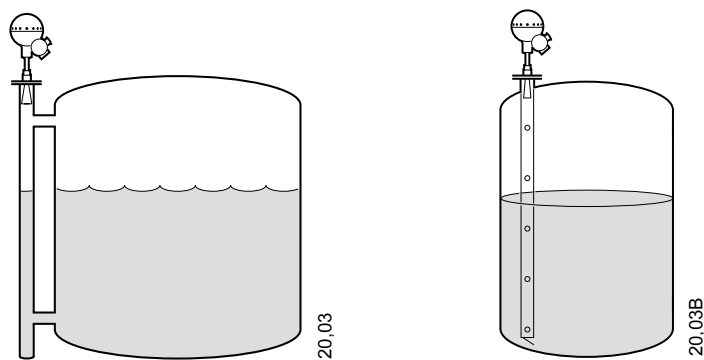

Still-pipe or bridle pipe mounting is recommended for LPG tanks and other applications where surface conditions may be extremely turbulent. By using a pipe, foam and turbulence is reduced. Accuracy may, however, be reduced in bridle and still pipe applications.

Rosemount 5600 Series

For Still Pipes

The 3, 4 and 6 in. cone antennas are designed to fit into new or existing still pipes with the corresponding pipe size. A gap between the antenna opening and the pipe of up to 0.4 in. (10 mm) may occur. In most applications this gap has only a limited effect on the measuring performance.

It is always recommended to have the gap as small as possible, since larger gaps cause larger inaccuracies.

Figure 2-38. 3, 4, and 6 in. Cone Antenna in still pipe - gap between pipe and antenna

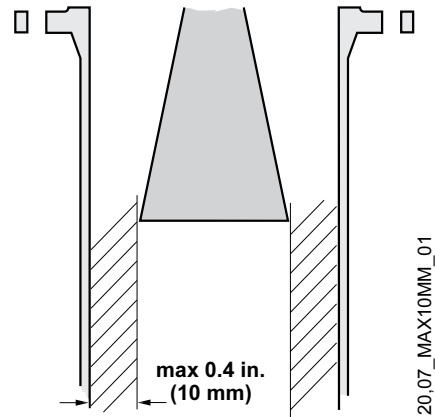

For Bridle Pipes

For Bridle applications the basic guidelines are similar to the guidelines written above for Still Pipes, i.e. that the 3, 4 and 6" Cone antennas will fit the corresponding pipe sizes, and you should try to get the gap as small as possible. If possible, and if the application allows for it, another general guideline is to keep the pipe inlet as small as possible.

In more difficult bridle applications with inlet pipes larger than 2 in. or in pipes with severe contamination can be expected, the antenna size should be customized to better fit the pipe. In this case do the following:

- a. Measure the inner diameter of the pipe.
- b. Cut the cone antenna so that it fits inside the Bridle Pipe.
- c. Make sure that the gap between the pipe and the antenna is smaller than 0.04 inches (1 mm).

Please contact your local Emerson Process Management representative for details about a factory-cut antenna.

Figure 2-39. Bridle Pipe installation guidelines

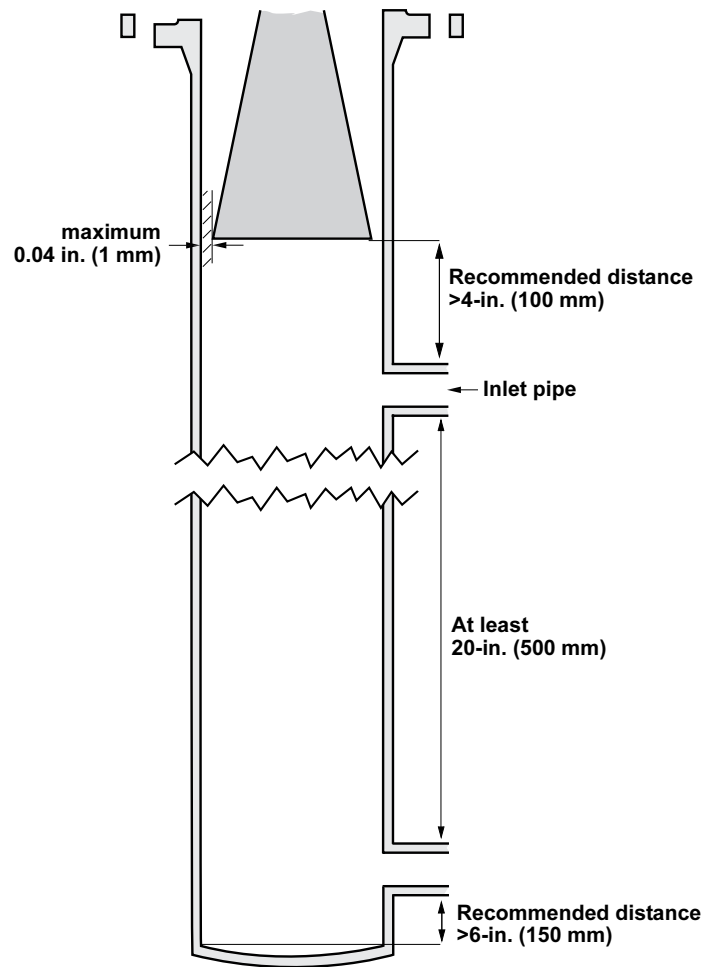

5600_07_AB.EPS

MEASUREMENT IN LARGE PIPES

When using standard cones in larger (8-in. or larger) still pipe installations, there is a risk for measurement problems. When standard linear shaped cones are used in pipes, more than one microwave mode is generated and each mode has a unique propagation speed. This is a radar physics problem that is common to all radar gauges when linear shaped cones are used.

In larger pipes, the amplitude of echoes generated by the “unwanted” modes may become rather high, and may result in loss of the surface echo at certain locations in the pipe. In addition, there may be measurement errors associated with two closely spaced echoes where the gauge will not lock on a single target.

The relative amplitude of the unwanted modes in a straight cone is proportional to the product of the cone angle and the diameter in the cone opening. Therefore measurement error increases as pipe diameter increases since the cone angle is the same for all the cones.

Due to this issue, Emerson Process Management does not recommend using the 5600 Series 8-in. cone antennas for larger pipe measurements. Instead, a special pipe antenna should be used.

Table 2-6. Recommendations

	Pipe Size		
	3-in. (76 mm)	4-in. (102 mm)	6-in. (152 mm)
Maximum measuring range	65 ft (20 m)	65 ft (20 m)	65 ft (20 m)
Maximum hole size (∅)	0.24 (6 mm)	0.28 (7 mm)	0.39 (10 mm)
Maximum number of holes per meter	2	2	2
Deflection plate required	Yes	Yes	Yes

Mounting the Antenna

1. Mount the antenna and the transmitter head in the same way as a standard cone antenna (see “Mounting the Cone Antenna - PTFE sealing” on page 2-14).

Figure 2-40. Mounting the antenna and transmitter head

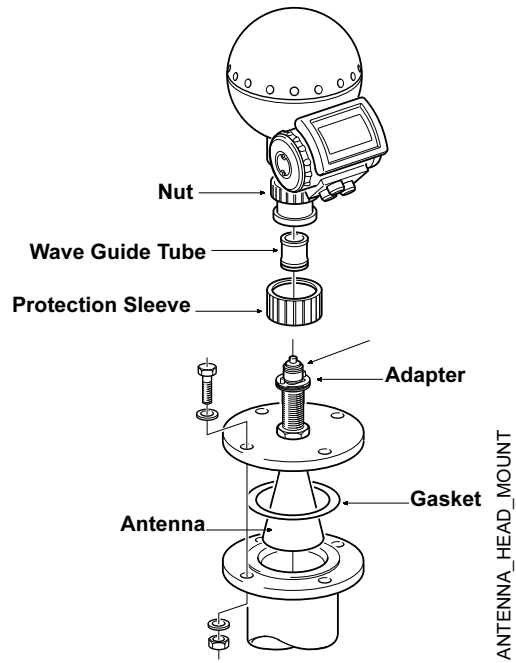

2. Make sure that the inclination of the transmitter is less than 1°.

Figure 2-41. Inclination less than 1°

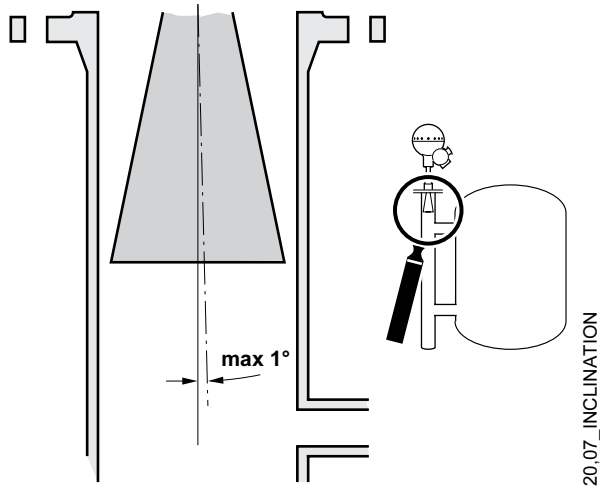

3. In order to minimize the influence of disturbing echoes from inlet and outlet pipes you may need to rotate the transmitter head 90°.

Figure 2-42. Example of rotating the transmitter head to minimize disturbing echoes

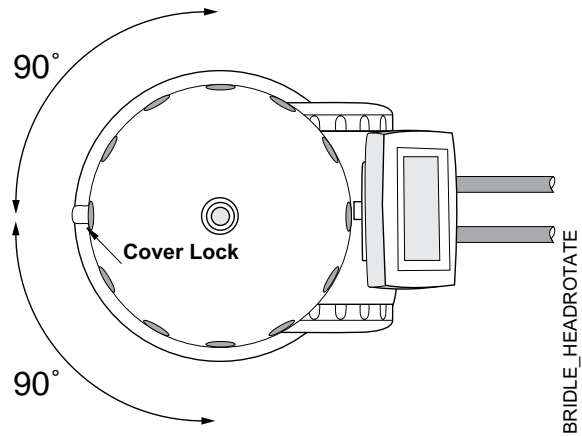

MOUNTING THE PARABOLIC ANTENNA

Figure 2-43. Parabolic Antenna Dimensions

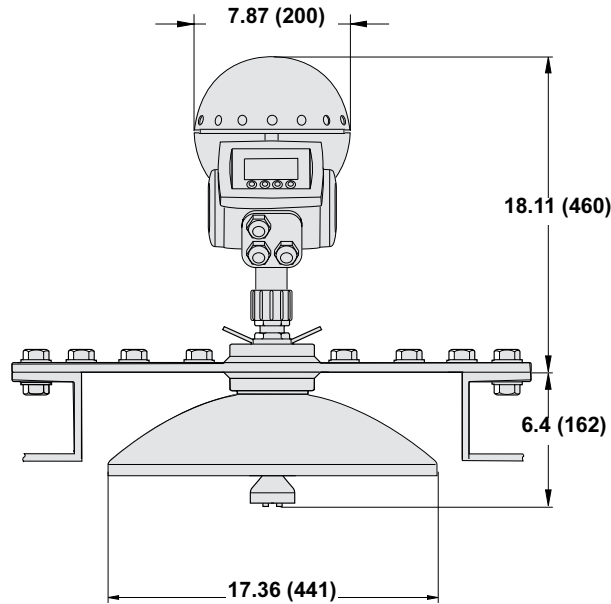

NOTE
Dimensions are in inches (millimeters)

.5600/5600_09_AA.EPS

Mounting the Flange Ball

1. The flange should be between 0.24 and 1.18 inches (6 and 30 mm) thick. Make sure the diameter of the hole is 3.78 in (96 mm).
2. Make a small recess in the flange hole.

Figure 2-44. Recess Hole

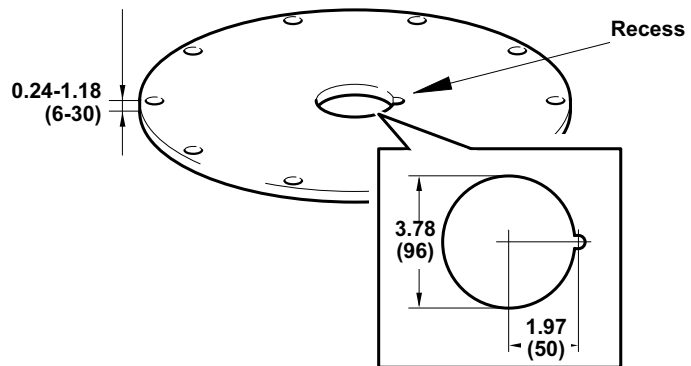

PARANT_FLANGE

- Put the O-ring on the flange and insert the Flange Ball into the hole. Make sure the pin on the side of the Flange Ball fits into the corresponding recess on the flange.

Figure 2-45. Put the O-ring on the flange

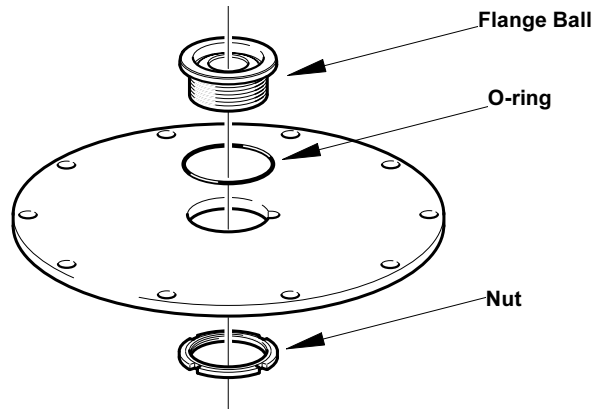

PARENT_FLANGEBALL

- Tighten the nut. Make sure the Flange Ball fits tightly to the flange.
- Secure the nut by tightening the locking screw.

Figure 2-46. Secure the nut

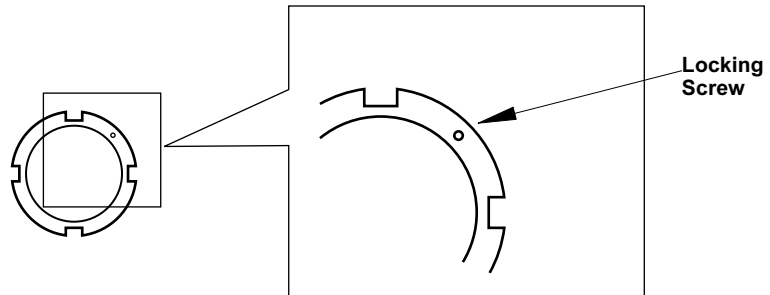

PARENT_NUT_LOCKSCREW

Mounting the antenna

1. Fit the Parabolic Reflector to the Antenna Feeder and mount the five M5 screws that were delivered by Emerson Process Management.

Figure 2-47. Mount the five M5 screw

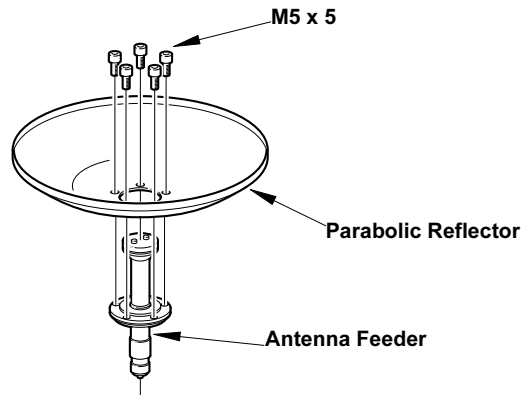

PARANT_PARABOLICREFLECTOR

2. Tighten the screws.
3. Put the two O-rings in the grooves on the upper surface of the Flange Ball.

Figure 2-48. Put the two O-rings in the grooves in the grooves

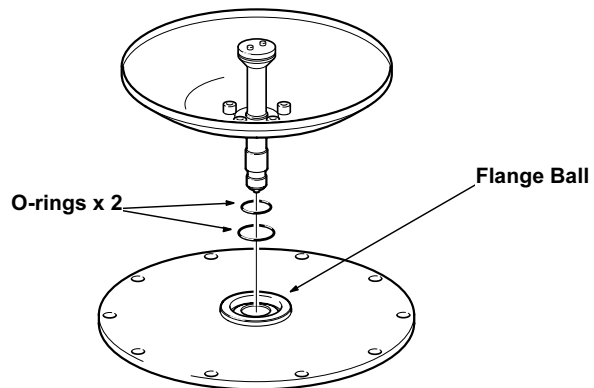

PARANT_FLANGEBALL

4. Turn the flange around and mount the antenna feeder on the flange. Mount the washers and nuts.

Figure 2-49. Mount washers and nuts

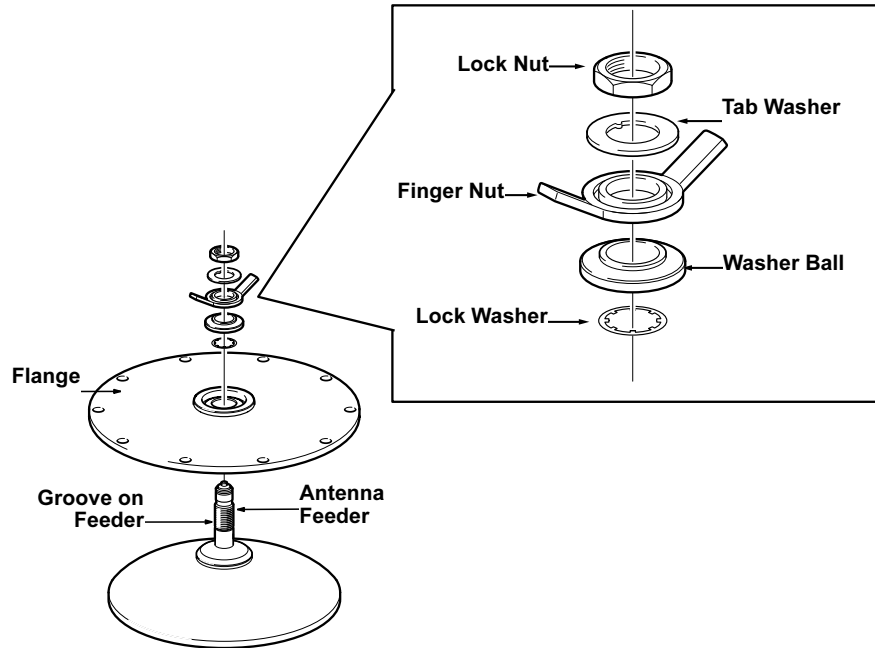

5600/5600_12_AA.EPS

5. Tighten the Finger Nut and the Lock Nut loosely.
6. Place the antenna on the tank nozzle and tighten the flange screws.

Figure 2-50. Tighten the flange screws

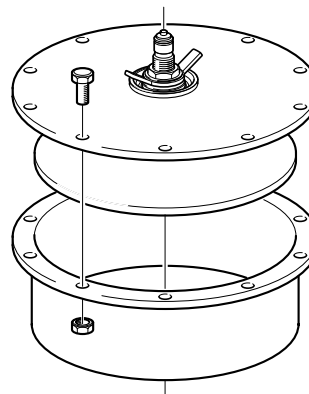

PARANT_TANKNOZZLE_T30

7. Rotate the antenna so the groove on the Antenna Feeder is directed 90° to the tank wall.

Figure 2-51. Groove on Antenna Feeder

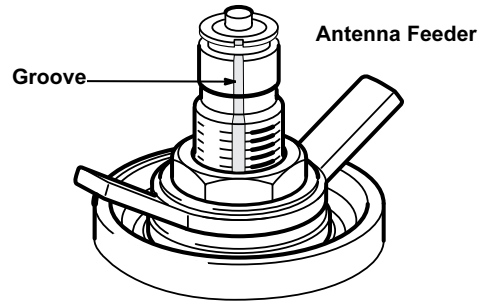

PARANTANTENNAFEEDER.EPS

8. Tighten the Finger Nut and the Lock Nut.
9. Mount the adapter nut on top of the antenna feeder. Tighten the adapter nut firmly.
10. Insert the Waveguide Tube into the Upper Waveguide.

Figure 2-52. Insert the Waveguide Tube into the Upper Waveguide

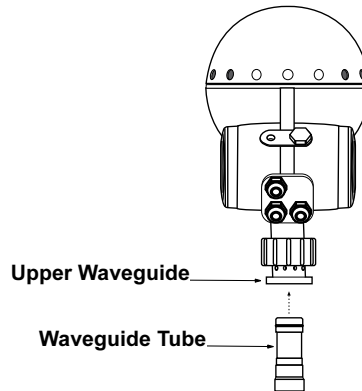

PA_WAVEGUIDETUBE.EPS

11. Carefully mount the Transmitter Head onto the adapter and tighten the Upper Waveguide Nut by hand. Make sure that the guide pins on the adapter fits into the holes on the Upper Waveguide.

Figure 2-53. Mount the Transmitter

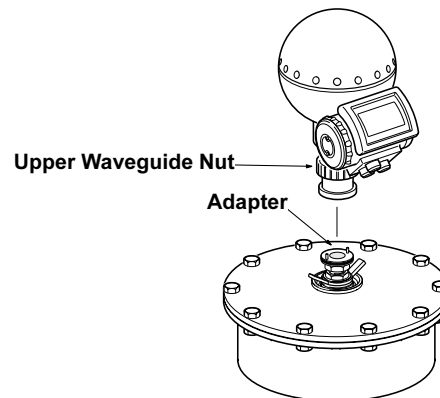

PARANT_PRO_THMOUNT_T30.EPS

Rosemount 5600 Series

- When the antenna inclination is adjusted to obtain optimum performance (Figure 2-54), tighten the finger nut and the lock nut firmly. Secure by folding the tab washer over the lock nut (Figure 2-55).

Figure 2-54. Inclination of Parabolic Antenna.

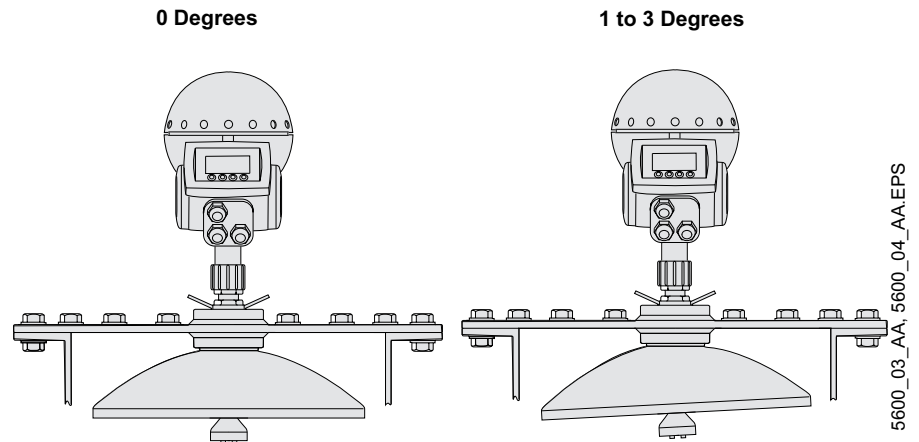

NOTE

Normally the antenna should be mounted with inclination 0° . However, in some applications, for example solid products, a small inclination of the antenna may improve the performance. This may also be the case if there are disturbing echoes from objects in the tank.

Figure 2-55. Fold the tab washer over the lock nut.

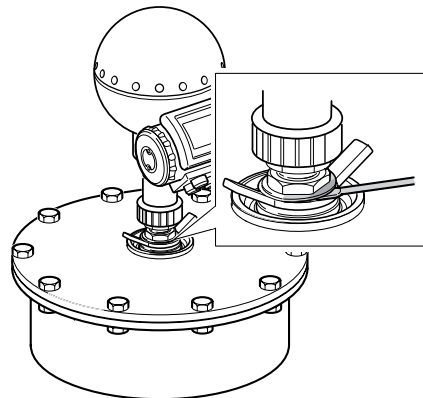

MOUNTING THE EXTENDED CONE ANTENNA

1. Mount the antenna and transmitter head in the same way as a transmitter with a standard cone antenna (see “Mounting the Cone Antenna - PTFE sealing” on page 2-14).

Figure 2-56. Mounting the antenna and transmitter head

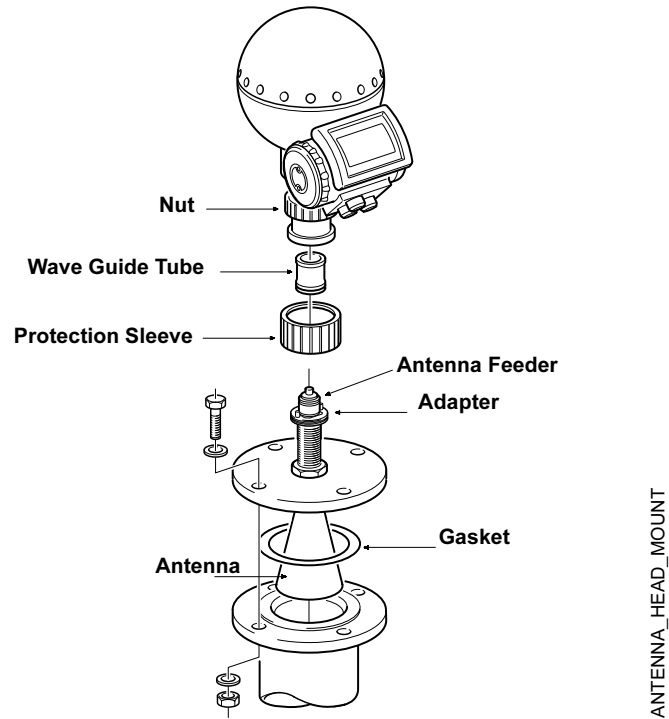

2. When the transmitter is mounted, the following antenna parameters must be adjusted by using the configuration software:
 - Tank Connection Length (TCL),
 - Hold Off (H) distance.

See page 2-38 and page 2-39 for more information on how to set the Hold Off distance and the Tank Connection Length for a Cone Extension antenna. See also Section 4: Configuration for more information about these parameters.

Rosemount 5600 Series

Setting the Tank Connection Length (TCL)

To set the Tank Connection Length, use one of the following procedures for Standard and Non-Standard Extended Cone Antenna.

Standard Extended Cone Antenna

For the 20 in. (500 mm) extended cone the following TCL_{ext} values can be used:

Table 2-7. Standard Extended Cone Antenna

Antenna Type	3 inch diameter = 68mm	4 inch diameter = 90mm	6 inch diameter = 138mm
$TCL_{ext}/PTFE$	0.019 (0.489)	1.90 (0.482)	1.88 (0.477)
$TCL_{ext}/Quartz$	2.08 (0.529)	2.06 (0.522)	2.04 (0.517)

Non-Standard Extended Cone Antenna

To adjust the TCL value do the following:

1. Start the Radar Master configuration software.
2. From the Antenna Type drop down list choose User Defined.
3. Enter the new TCL value.
Use the following formula to calculate the appropriate Tank Connection Length (TCL):

$$TCL_{ext} = TCL_{cone} + K*(L_{ext} - L_{antenna})$$

where:

- TCL_{ext} = the TCL adjusted to the extended cone antenna (See Table 2-7).
- TCL_{cone} = the default TCL for a standard cone antenna without extension. Note that there are different TCL values for tank sealing PTFE and Quartz, see Table 2-8.
- L_{ext} = the measured length of the extended cone antenna.
- $L_{antenna}$ = the length of the standard cone antenna without extension.
- K = a constant related to the antenna inner diameter.

Table 2-8. Non-Standard Extended Cone Antenna

Antenna Type	3 inch diameter = 68mm	4 inch diameter = 90mm	6 inch diameter = 138mm
K	0.035	0.020	0.008
$L_{antenna}$	0.094	0.148	0.261
$TCL_{cone}/PTFE$	0.475	0.475	0.475
$TCL_{cone}/Quartz$	0.515	0.515	0.515

Setting the Hold Off Distance

To set a new Hold Off distance do the following:

1. Start the configuration software.
2. In the Hold Off/New input field type the desired Hold Off distance. Use the following formula in order to calculate the appropriate Hold Off (H) distance:

$$H = 1.2 \text{ inches} + L_{\text{ext}} \quad (H = 0.03 \text{ meters} + L_{\text{ext}})$$

where:

- L_{ext} is the length of the extended cone antenna

Figure 2-57. Extended cone antenna

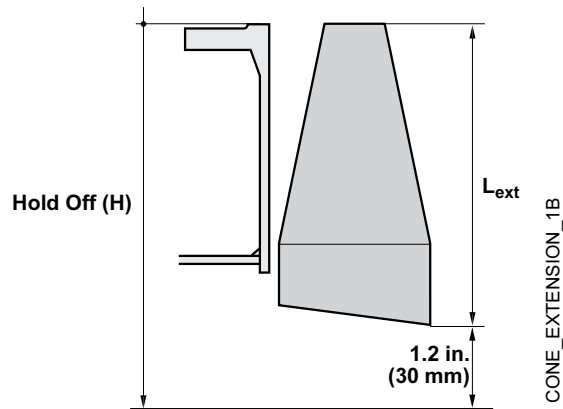

Rosemount 5600 Series

Installation Requirements Extended Cone Antenna

Figure 2-58. Extended Cone
Antenna Dimensions

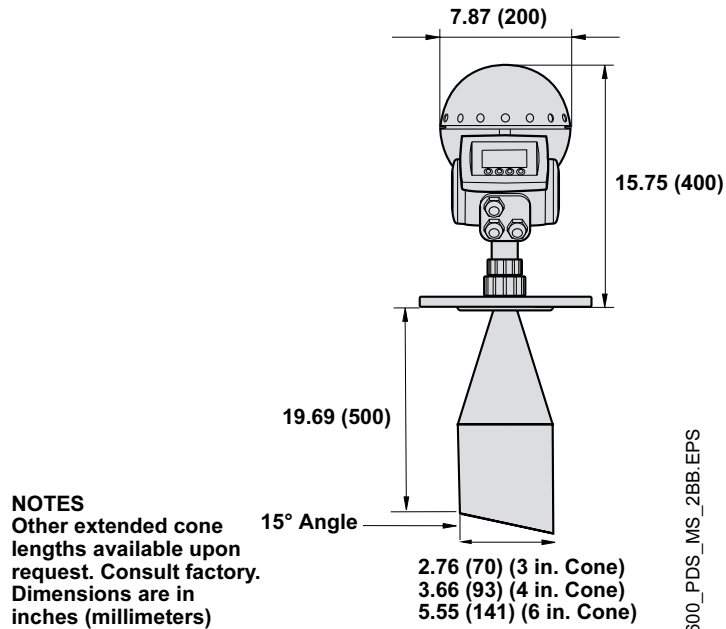

The Extended Cone antenna is suitable for tanks with long nozzles or tanks where measurements should be avoided in the region close to the nozzle.

Use the Extended Cone antenna if:

- the nozzle is high, see Figure 2-59:
ANSI 3" antenna for nozzles higher than 9.8 in. (250 mm),
ANSI 4" antenna for nozzles higher than 11.8 in. (300 mm),
ANSI 6" antenna for nozzles higher than 15.8 in. (400 mm),
- there are disturbing objects close to the tank opening, see Figure 2-60,
or
- there is a rough surface at the inside of the nozzle or there is a height difference between nozzle sides, see Figure 2-61.

Figure 2-59. Example of a high nozzle

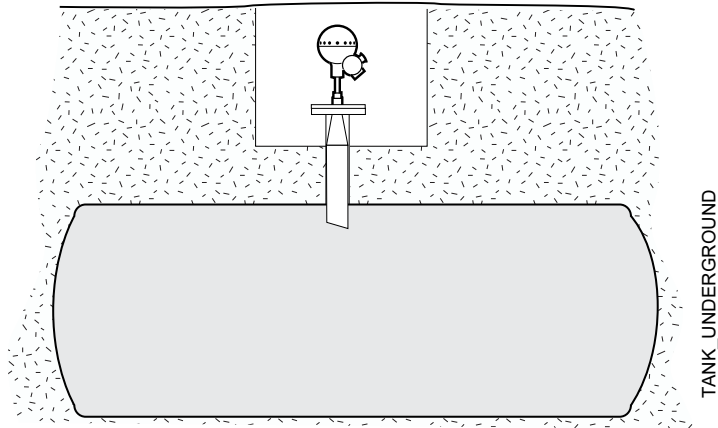

Figure 2-60. Example of disturbing objects close to the tank nozzle

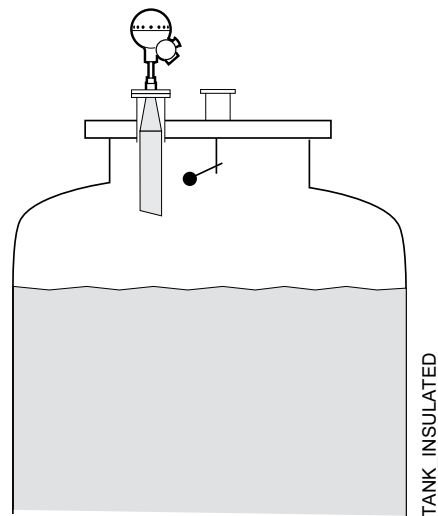

Figure 2-61. Examples of problem nozzles

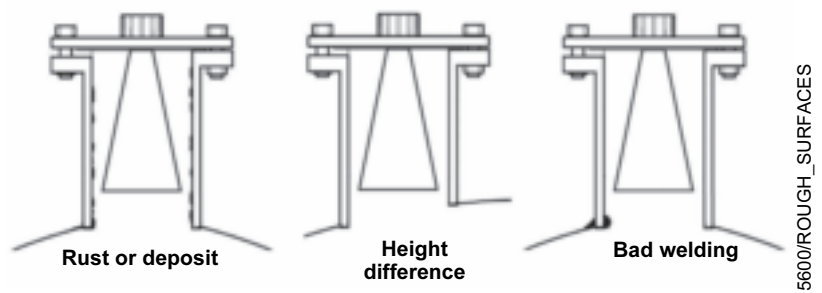
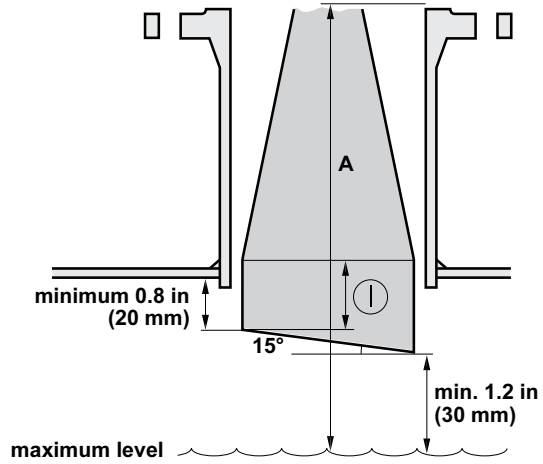

Figure 2-62. Total distance between flange and product level



1. Measure the total distance **A** between the flange and the maximum product level.
2. The standard length of the Extended Cone antenna is 20 in. (500 mm). If **A** is less than 20 inches (500mm), then the cone may be cut so these minimum dimensions are met.

Due to the slanting opening of the antenna the direction of the radar beam is slightly changed towards the short end of the antenna opening. If objects are present which may cause disturbing radar echoes, the antenna should be oriented in such a way that the disturbing objects do not interfere with the radar signal. The short side should be turned away from disturbing objects on the most open part of the tank.

MOUNTING THE CONE ANTENNA WITH FLUSHING CONNECTIONS

Figure 2-63. Cone Antenna with Integrated Flushing Connection Dimensions

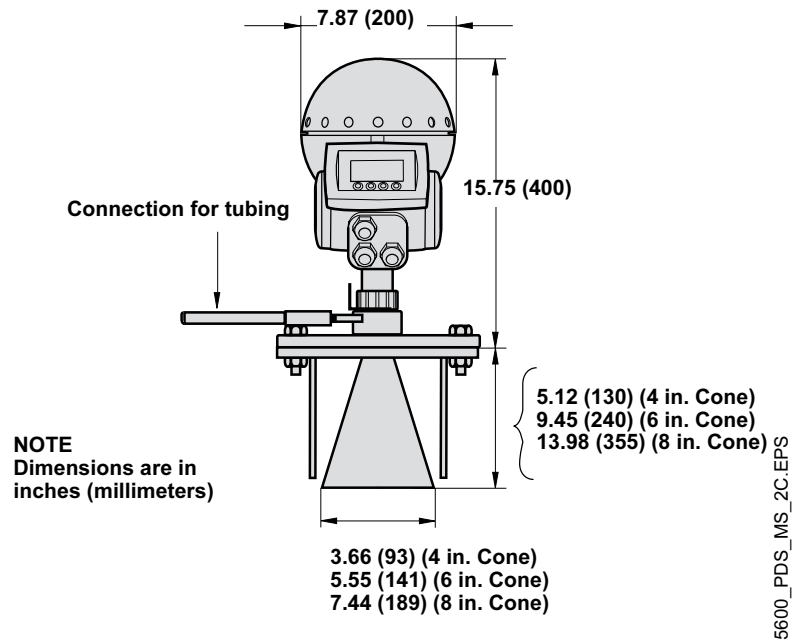

1. The flange is a part of the antenna assembly and welded to the cone antenna. Carefully fit the antenna assembly and appropriate gasket on the tank nozzle.

Figure 2-64. Mount the flushing cone antenna on the nozzle

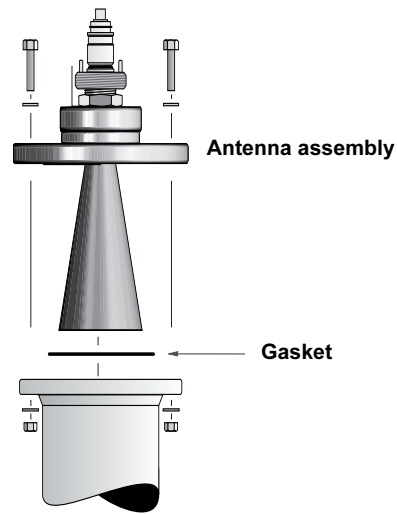

2. Insert the wave guide tube into the upper wave guide.
Make sure the o-ring at the lower end of the wave guide tube is in place.

Figure 2-65. Insert wave guide tube

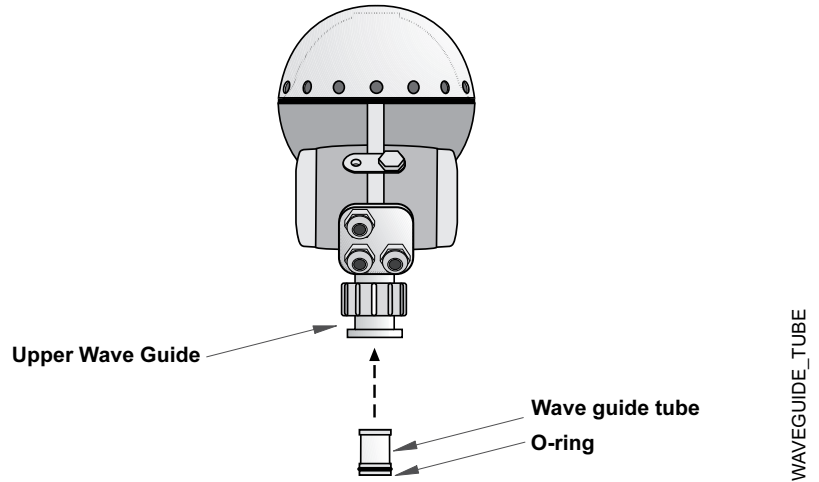

3. Mount the transmitter head and tighten the nut. Check that the guide pins on the adapter enter the corresponding grooves on the upper wave guide.

Figure 2-66. Mount the transmitter head

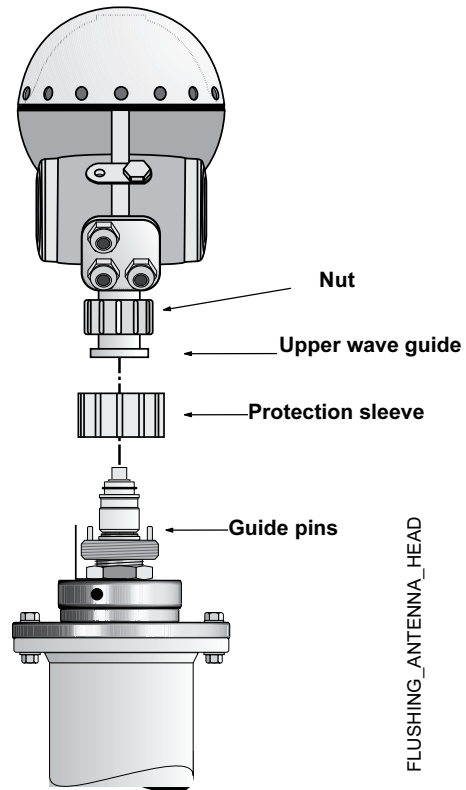

Rosemount 5600 Series

4. Connect your tubing to the antenna for cleaning, purging, or cooling purposes. Use a minimum 0.4 in. (10 mm) tube or pipe. Typical media to use are:
 - nitrogen,
 - air,
 - water, or
 - steam.

Figure 2-67. Connect tubing to antenna

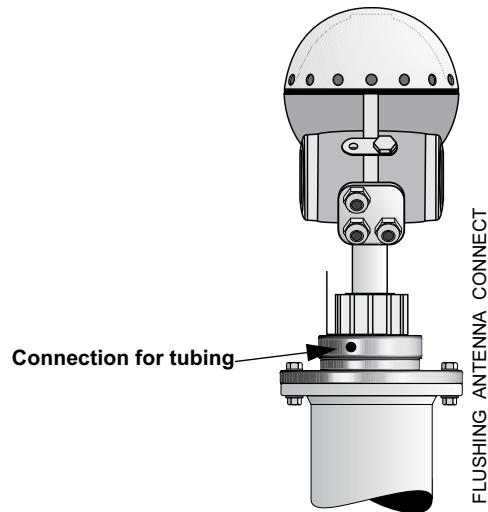

Rosemount 5600 Series

Reference Manual
00809-0100-4024, Rev BA
September 2005

Section 3 Electrical Installation

Safety Messages	page 3-1
System Overview	page 3-2
Cables	page 3-3
Power Supply	page 3-3
Grounding	page 3-4
HART Electrical Installation	page 3-4
FOUNDATION Fieldbus Electrical Installation	page 3-8
Connecting the 2210 Display Unit	page 3-12

SAFETY MESSAGES

Procedures and instructions in this section may require special precautions to ensure the safety of the personnel performing the operations. Information that raises potential safety issues is indicated by a warning symbol (⚠). Please refer to the following safety messages before performing an operation preceded by this symbol.

⚠ WARNING

Explosions could result in death or serious injury:

Verify that the operating environment of the transmitter is consistent with the appropriate hazardous locations certifications.

Before connecting a HART-based communicator in an explosive atmosphere, make sure the instruments in the loop are installed in accordance with intrinsically safe or non-incendive field wiring practices.

Do not remove the transmitter cover in explosive atmospheres when the circuit is alive.

⚠ WARNING

Failure to follow safe installation and servicing guidelines could result in death or serious injury:

Make sure only qualified personnel perform the installation.

Use the equipment only as specified in this manual. Failure to do so may impair the protection provided by the equipment.

Do not perform any service other than those contained in this manual unless you are qualified.

High voltage that may be present on leads could cause electrical shock:

Avoid contact with leads and terminals.

Make sure the main power to the 5600 Series Radar Level Transmitter is off and the lines to any other external power source are disconnected or not powered while wiring the transmitter.

SYSTEM OVERVIEW

Power Supply

Connect the power supply to terminals 3 and 4 in the non-intrinsically safe Junction Box (EEx e).

Analog Outputs

There are two analog outputs which can be of passive or active type (external or internal loop supply). The primary output has a HART interface.

Connect the primary analog output to terminals 1 and 2.

Use the EExe junction box for non-intrinsically safe applications, and the EExi junction box for intrinsically safe applications.

Digital Communication

The 5600 Series Radar Level Transmitter can be equipped with HART interface, and can be either connected EExe or EExi.

The Foundation fieldbus can be connected to either the intrinsically safe (EExi) or the non-intrinsically safe (EExe) junction box.

Display Unit

Connect the intrinsically safe Rosemount 2210 Remote Display Unit to terminals 5, 6, 7 and ground in the intrinsically safe (EExi) junction box.

Transmitter Junction Box

The standard version is equipped with two separate junction boxes, one non-intrinsically safe and one intrinsically safe part. There is also an optional version with two non-intrinsically safe compartments.

Figure 3-1. Junction boxes X1 and X2

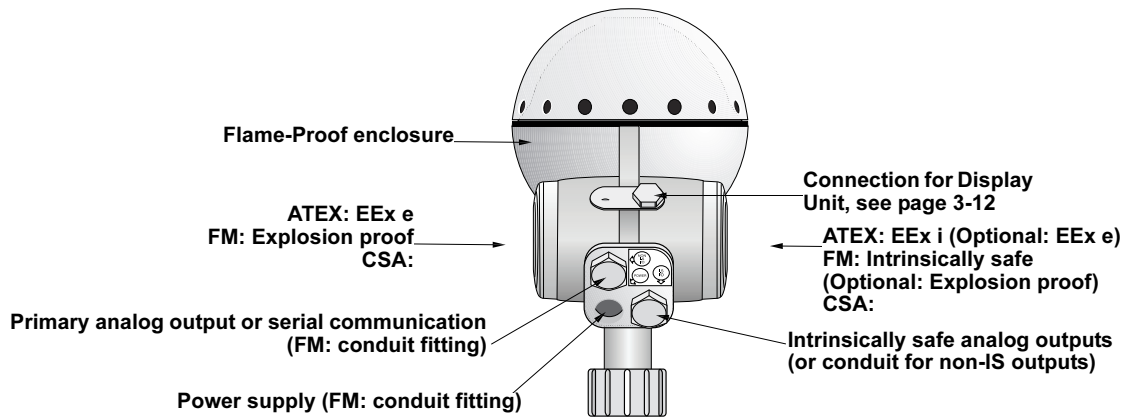

TH40HEAD_ED3

Figure 3-2. Schematic illustration of the Rosemount 5600 transmitter connection

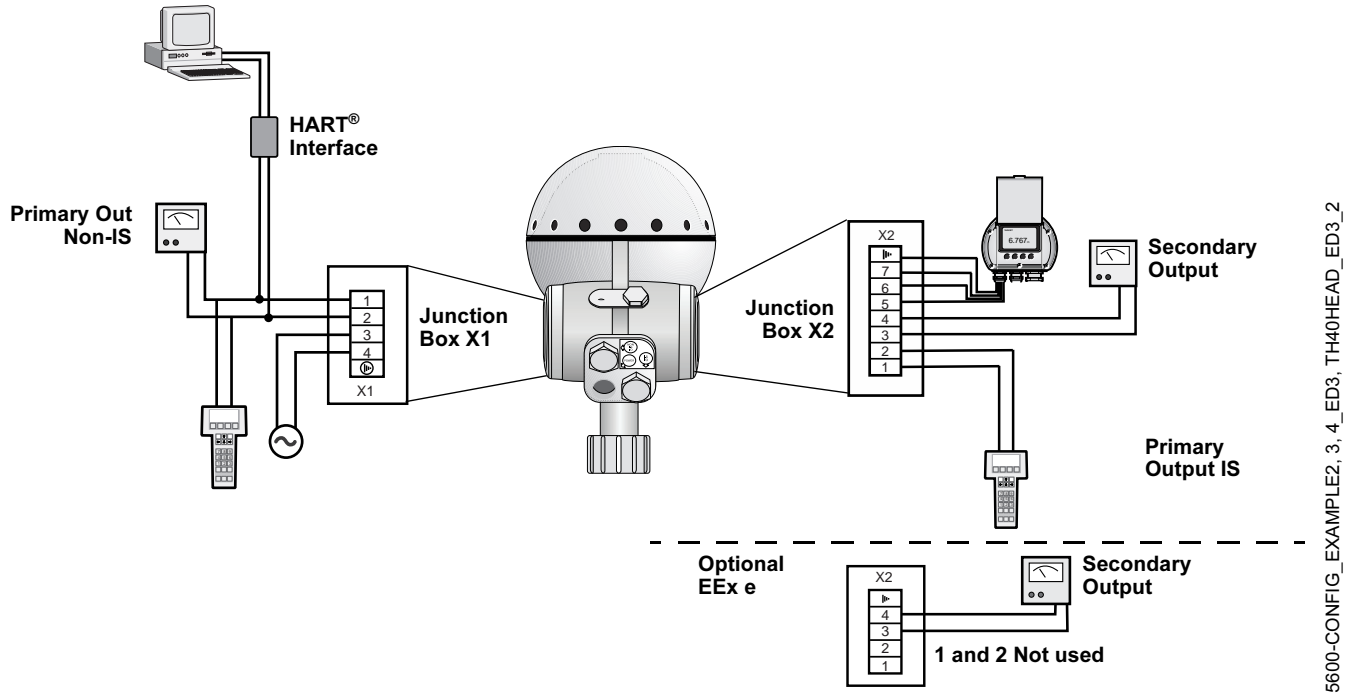

5600-CONFIG_EXAMPLE2, 3, 4_ED3, TH40HEAD_ED3_2

CABLES

Depending on local requirements, cable glands, or explosion proof conduits must be used for connection to the non-intrinsically safe junction box (EEx e). For the connection to the intrinsically safe junction box (EEx i) use cable glands with integral shield connection for cable diameter 6-12 mm or conduit.

Use shielded instrument cable 0.5 mm² (AWG 20) for analog outputs and serial communication. Use min. 0.5 mm² cable for power supply.

POWER SUPPLY

You can use either DC or AC as the built in power supply has a wide input range. The following specification is valid for the power supply:

- 24-240 V
- DC/AC 0-60 Hz
- 10 W
- 15 VA

There is no voltage selector in the electronics compartment since the transmitter power supply unit automatically adapts to the available voltage within specified limits.

NOTE

The minimum voltage required at the transmitter power terminals is 20V. Check that the voltage loss over the power cables is not large enough to make the voltage drop below 20V. The maximum voltage is 265V over the same power terminals.

Rosemount 5600 Series

HART

GROUNDING

ATEX

The flameproof enclosure must be connected to a potential equalizing network or the tank shell or according to national code of practice.

This grounding also serves as electrical safety ground. Additional connection to the protective ground terminal of terminal X1 in Junction Box EExe is not recommended except where required according to national code of practice. A ground loop with circulating current may occur. See Appendix B: Product Certifications.

Figure 3-3. Grounding connection

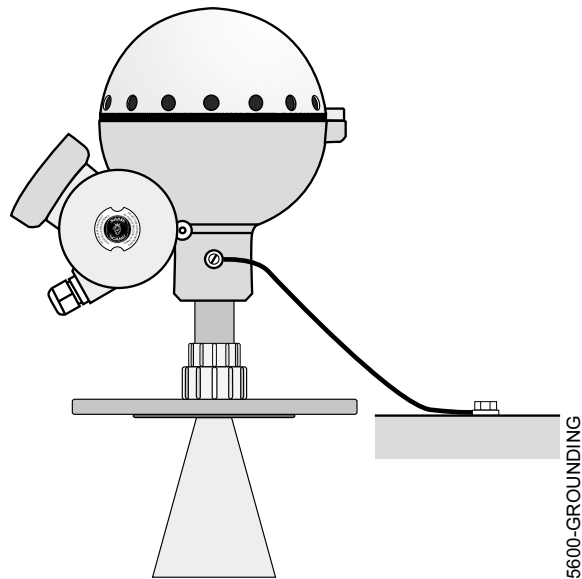

FM

Grounding is accomplished through the conduit pipes.

HART ELECTRICAL INSTALLATION

External Connections

Non-Intrinsically Safe Junction Box - EEx e

This Junction Box is for non-intrinsically safe connections and power supply.

Figure 3-4. Transmitter Terminal Block (Non-IS Wiring)

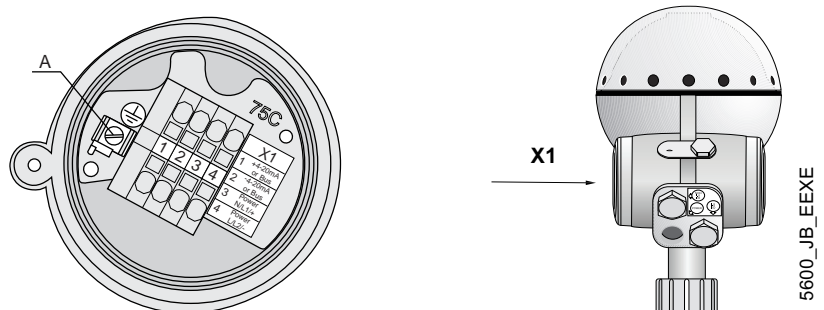

- 1-2 Non-intrinsically safe HART/4-20 mA primary analog output or non-intrinsically safe FOUNDATION fieldbus.
- 3-4 Power supply input
- A Electrical safety ground terminal

NOTE:
Redundant when the transmitter is grounded according to ATEX.

Cable shield

Connect the shield to the cable glands.

If conduit fittings are used no cable shield is used.

Intrinsically Safe Junction Box - EEx i

This Junction Box is for intrinsically safe connections and for connection of the Display Unit.

Figure 3-5. Transmitter Terminal Block (IS Wiring)

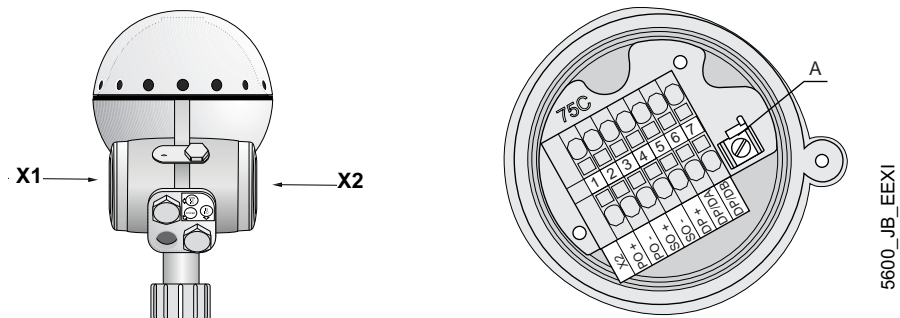

- 1-2 Intrinsically safe HART/4-20 mA primary analog output or intrinsically safe FOUNDATION fieldbus
- 3-4 Secondary analog output
- 5-7 Display Unit (6-7 also used for Sensor Bus see “Configuration Using the Sensor Bus Port” on page 6-16)
- A Ground terminal for Display Unit

Cable shield

Connect the shield to the cable glands.

If conduit fittings are used no cable shield is used.

Rosemount 5600 Series

HART

Optional Non-intrinsically Safe Junction Box

This is the standard intrinsically safe Junction Box (EExi) fitted with an alternative connector for connection of non-IS output if required.

Figure 3-6. Alternative Non-intrinsically safe junction box

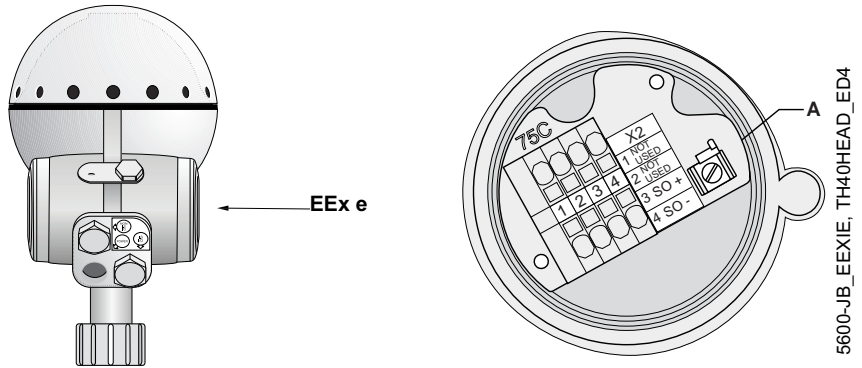

- 1-2 Not used
- 3-4 Non-intrinsically safe Secondary Analog Output
- A Ground terminal (not used)

Cable shield

Connect the shield to the cable glands.
 If conduit fittings are used no cable shield is used.

Connecting HART devices

Active output (internal loop supply)

For transmitters with active output a hand-held terminal or a HART modem can be connected as follows:

Figure 3-7. Typical hand-held communicator active output (primary)

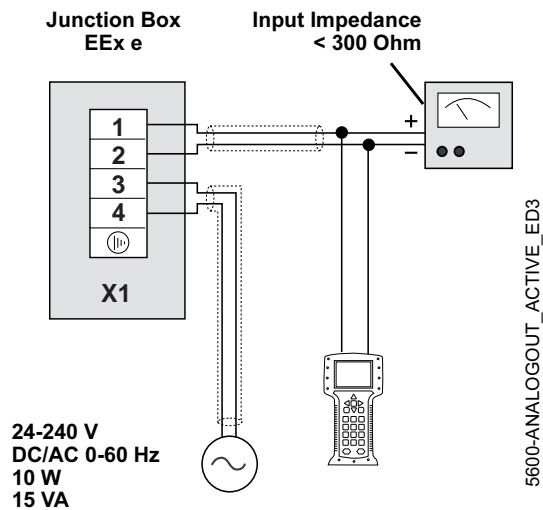

Passive output (external loop supply)

A hand-held terminal or a HART modem should not be connected directly across an external power supply. Instead, it should be connected across a load resistor of about 250 ohms.

Figure 3-8. Typical hand-held Communicator (passive output)

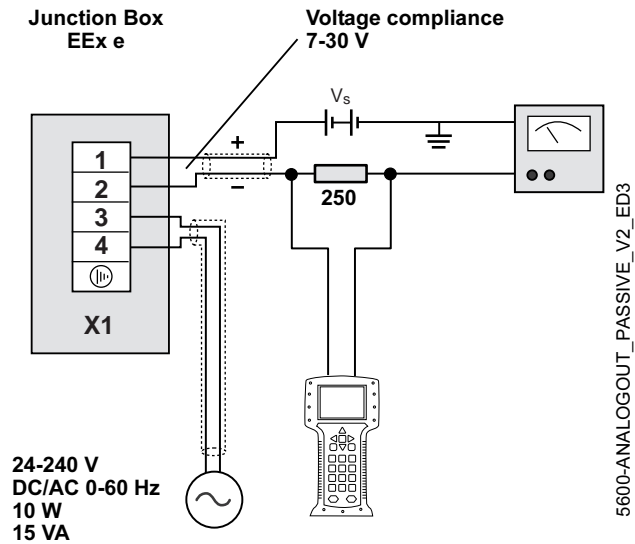

Intrinsically safe conditions

A hand-held intrinsically safe communicator can be connected in the hazardous area. The HART interface must be connected via a zener barrier in the safe area. It is also possible to use an intrinsically safe Ex classed HART interface which has a built in Zener barrier.

Figure 3-9. Typical hand-held Communicator connection in intrinsically safe conditions

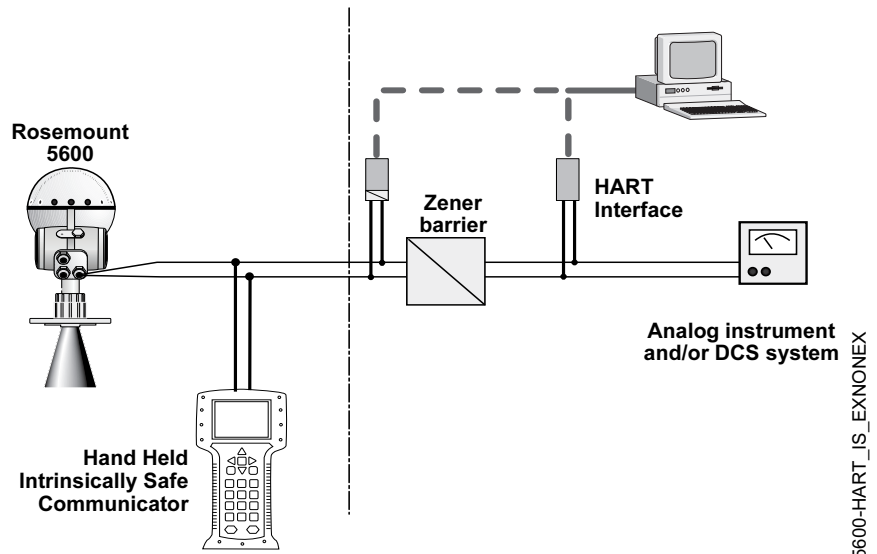

Non-Intrinsically safe conditions

Figure 3-10. Typical Hand-held Communicator connection in Non-intrinsically safe conditions

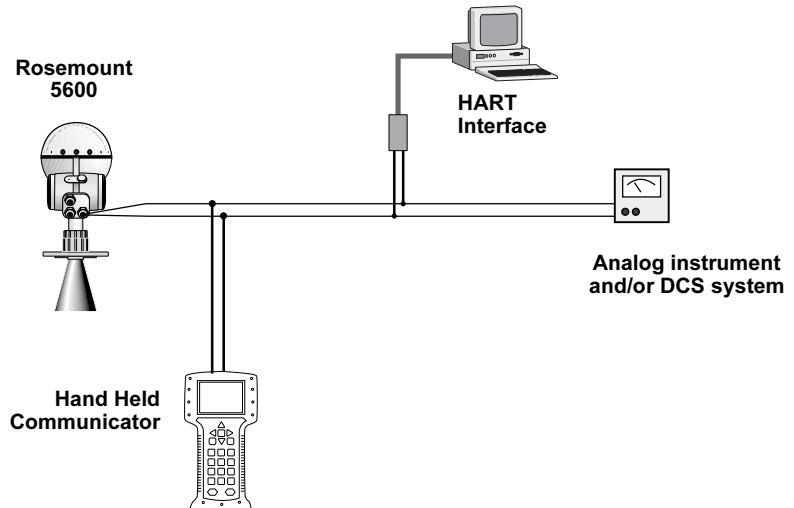

5600-HART_NONIS_EXN0EX

FOUNDATION Fieldbus

FOUNDATION FIELDBUS ELECTRICAL INSTALLATION

Power Supply

The transmitter requires separate power within the range 24-240 V AC or DC 0-60Hz. Tighten the terminal screws to ensure adequate contact. See "Power Supply" on page 3-3 and Figure 3-18 on page 3-14 for additional information.

Fieldbus Voltage limits: 9 to 32 V

Current Draw: 12.5 mA

For I.S. Applications:

$U_i < 30 \text{ V}$

$I_i < 300 \text{ mA}$

$P_i < 1.3 \text{ W}$

$C_i = 0 \text{ } \mu\text{F}$

$L_i = 0 \text{ mH}$

Fieldbus Connections

For best installation practices use a fieldbus type A cable. Do not run unshielded signal wiring in conduit or open trays with power wiring or near heavy electrical equipment. Do not remove the transmitter cover in explosive atmospheres when the circuit is alive. Use ordinary copper wire of sufficient size to ensure that the voltage across the fieldbus terminals does not go below 9 V dc.

NOTE

Do not apply high voltage (e.g. ac line voltage) to the fieldbus terminals. Abnormally high voltage can damage the unit.

Model Code

Use the Model Code located on your fieldbus transmitter to determine wiring connection.

Figure 3-11. Example of a fieldbus label



5600/LABELS/FIELDBUSLABEL_02A_02B.EPS

FOUNDATION Fieldbus

External Connections

Non-Intrinsically Safe Wiring

Figure 3-12. Transmitter Terminal Block (Non-IS Wiring)

NOTE:
 1-2= BUS Connection
 3-4 =Power Connections
 A= Ground Terminal

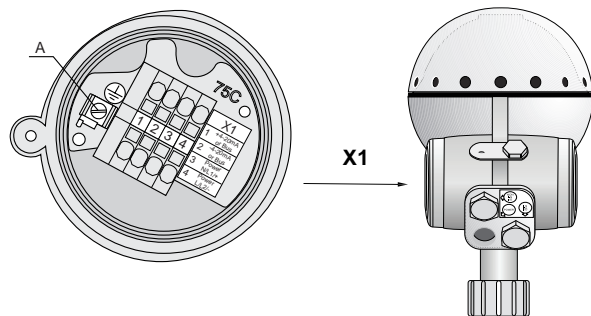

5600_JB_EEXE

Rosemount 5600 Series

1. Connect fieldbus wires to terminal 1 and 2 on the X1 side. These terminals are marked BUS terminals. The BUS terminals are polarity insensitive.
2. Connect the power wires to terminal 3 and 4 on the X1 side. These wires are separate from the fieldbus wires.

Intrinsically Safe Wiring

Figure 3-13. Transmitter Terminal Block (IS Wiring)

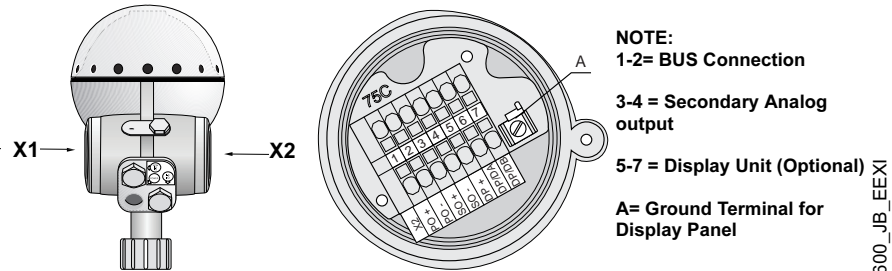

1. Connect fieldbus wires to terminals 1 and 2 on the X2 side. These terminals are marked BUS terminals. The BUS terminals are polarity insensitive.
2. Connect the power wires to terminal 3 and 4 on the X1 side. These wires are separate from the fieldbus wires.

NOTE

Do not ground out the live signal wiring to the housing when working on a segment. Grounding the communication wires may result in temporary loss of communication with all devices on the segment.

Hazardous Locations

Refer to Appendix B: Product Certifications.

Grounding

Signal wiring of the fieldbus segment can not be grounded. Grounding out one of the signal wires will shut down the entire fieldbus segment.

Shield Wire Ground

To protect the fieldbus segment from noise, grounding techniques for shield wire usually require a single grounding point for shield wire to avoid creating a ground loop. The ground point is typically at the power supply.

Connecting fieldbus devices

Figure 3-14. Rosemount 5600 Radar Transmitter Field Wiring

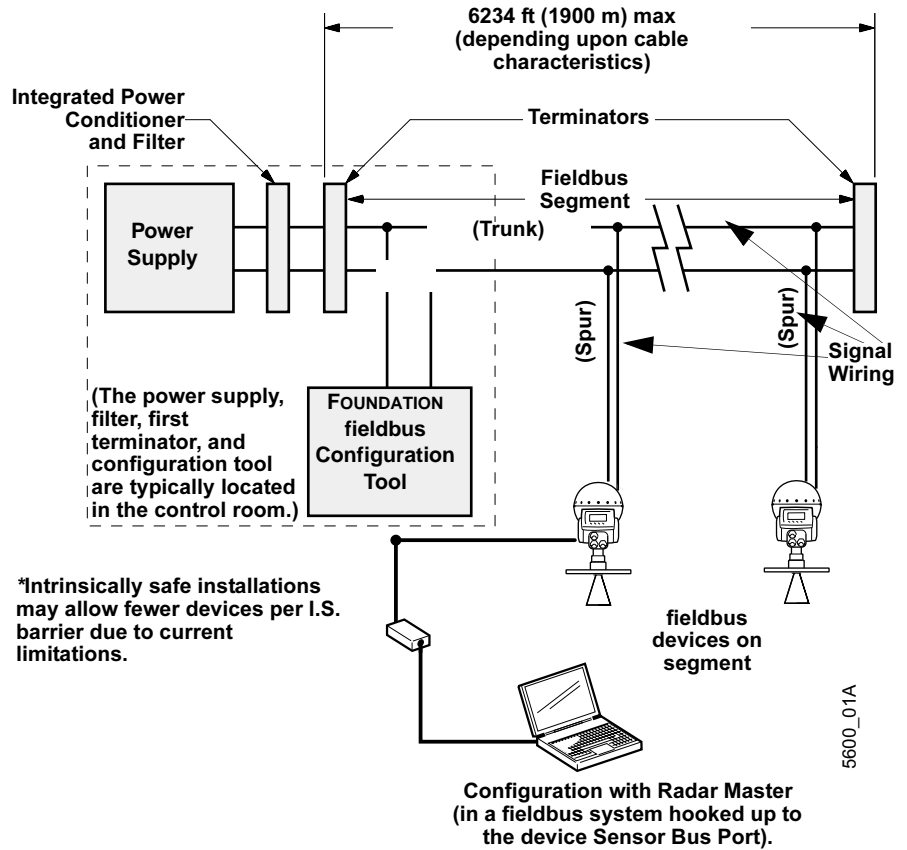

FOUNDATION Fieldbus

5600_01A

Rosemount 5600 Series

CONNECTING THE 2210 DISPLAY UNIT

The Rosemount 2210 Display Unit can be factory mounted on the 5600 Series Radar Level Transmitter enclosure or remotely mounted. The Display Unit can be used for configuration of the transmitter as well as for displaying tank data (see Section 7: 2210 Display Unit Configuration for information on how to operate the transmitter by using the Display Unit).

Figure 3-15. Rosemount 2210 Display Unit Connection

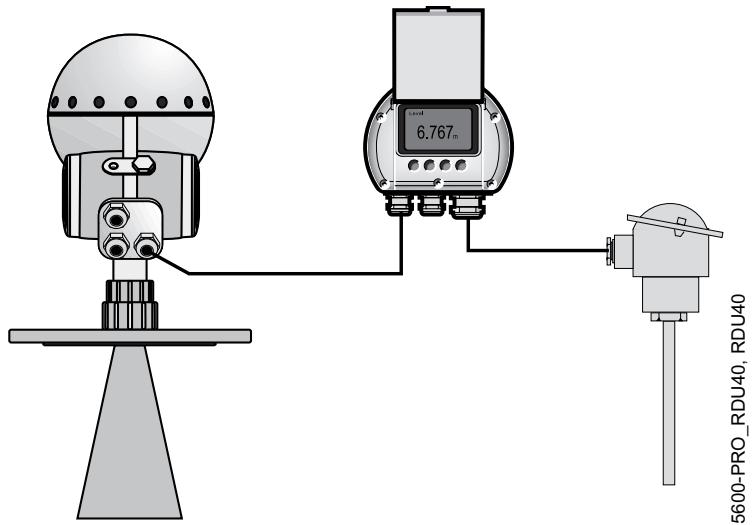

2210 Display Unit

The Display Unit is connected to the Intrinsically Safe Junction Box on the front of the transmitter head:

Figure 3-16. Intrinsically safe junction box

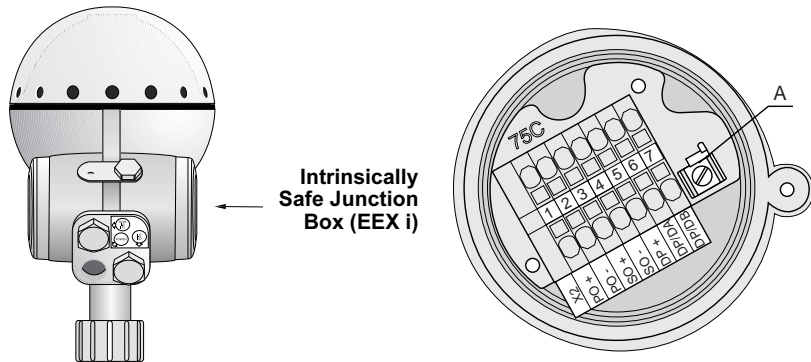

5600-TH40HEAD_ED3, JB_EEXI_01AA.EPS

The Display Unit is offered in three versions:

- Mounted on the transmitter
- Remote mounted up to 330 ft (100m)
- Remote mounted with Temperature option card in it. This card allows for up to 6 temperature sensors to be hooked up. See “Temperature Measurement” on page 3-14 for temperature connections.

Connect the Display Unit to the X2 terminal in the Intrinsically Safe Junction Box by the following four wires:

- Grounding wire to the ground terminal
- Signal wires to terminal 6 and 7
- Supply voltage to terminal 5

Figure 3-17. Connection of junction box with and without temperature option

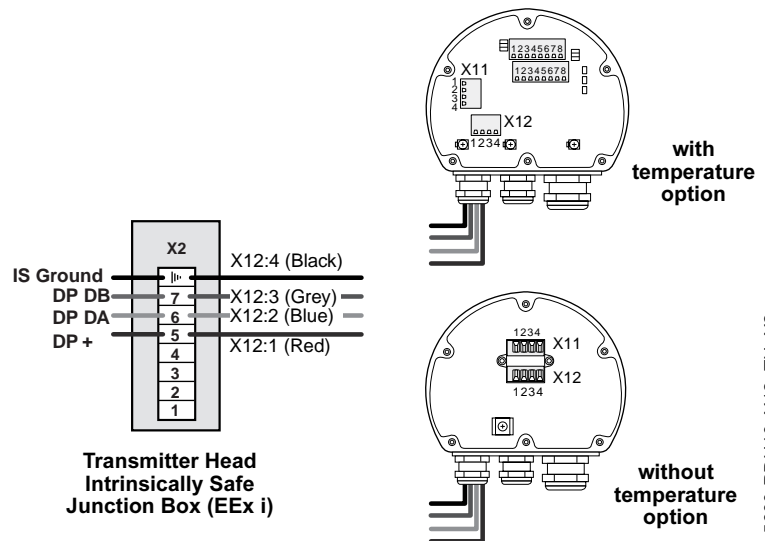

5600-RDU40_X12_TH_X2

Rosemount 5600 Series

Connecting the Rosemount 2210 Display Unit

1. For power supply connect a wire between terminal block X2, position 5 and terminal block X12, position 1.
2. For communication connect a wire between terminal block X2, position 6 and terminal block X12, position 2, and a wire between terminal block X2 position 7 and terminal block X12 position 3.
3. Finally for grounding connect a wire from the IS Ground screw in the X2 terminal compartment to terminal block X12 position 4.

Temperature Measurement

For temperature measurements you can use 1-3 3-wire RTD spot elements or 1-6 3-wire RTDs with common return. The sensors are connected to nozzle X17 and X18 on the optional TP40 board. Depending on the type of sensor that is used, different jumpers must be set on nozzles X24, X25, X26, X27 and X28, see Figure 3-18, Figure 3-19, and Figure 3-20.

Figure 3-18. Overview of the TP40 board

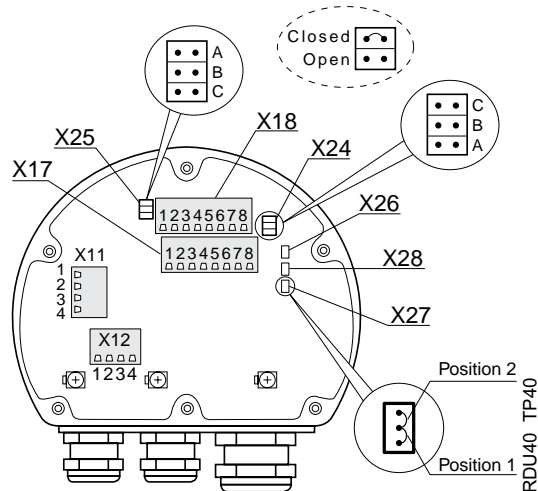

Spot elements 3-wire independent

Figure 3-19. Connecting the sensors - Spot Elements

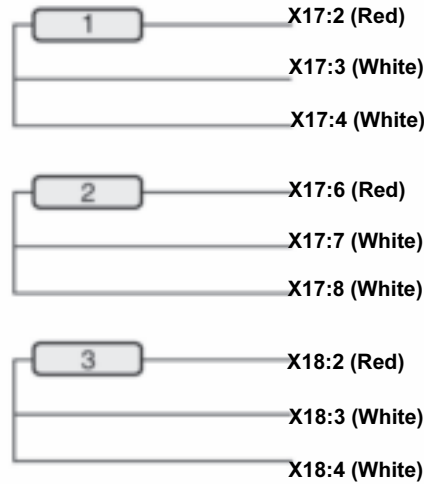

5600-RDU40_TP40

Jumper Settings

X24	A, B, C open
X25	A, B, C closed
X26	position 1
X27	position 1
X28	position 1

Multiple spot elements 3-wire common return

Figure 3-20. Connecting the Sensors - Multiple Spot Elements

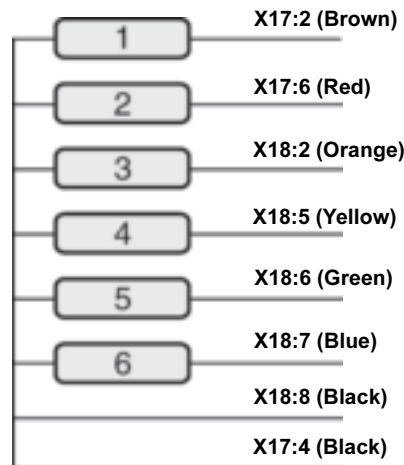

5600-RDU40_TP40

Jumper Settings

X24	A, B, C closed
X25	A, B, C closed
X26	position 2
X27	position 2
X28	position 2

Rosemount 5600 Series

Reference Manual
00809-0100-4024, Rev BA
September 2005

Section 4 Configuration

Antenna	page 4-3
Tank Geometry	page 4-5
Analog Output	page 4-7
Process Conditions	page 4-9
Temperature Measurement	page 4-9
Volume Calculation	page 4-10
Advanced Functions	page 4-11

Safety Messages

Procedures and instructions in this section may require special precautions to ensure the safety of the personnel performing the operations. Information that raises potential safety issues is indicated by a warning symbol (⚠). Please refer to the following safety messages before performing an operation preceded by this symbol.

WARNING

Explosions could result in death or serious injury:

Verify that the operating environment of the transmitter is consistent with the appropriate hazardous locations certifications.

Before connecting a HART-based communicator in an explosive atmosphere, make sure the instruments in the loop are installed in accordance with intrinsically safe or non-incendive field wiring practices.

Do not remove the transmitter cover in explosive atmospheres when the circuit is alive.

Rosemount 5600 Series

OVERVIEW

To be able to fully utilize the 5600 Radar Level transmitter it has to be properly configured. To configure the transmitter access the configuration parameters and assign them appropriate values. In this section you will find the parameters used and how they affect your application. The preferred user interface for the configuration is the Rosemount Radar Master software. See “Safety Messages” on page 5-1. Configuration can also be performed using the:

- AMS / 375 Field Communicator (see Section 5: HART Configuration)
- Foundation Fieldbus (see Section 6: FOUNDATION Fieldbus Configuration)
- 2210 Display Unit (see Section 7: 2210 Display Unit Configuration)
- DeltaV (see Section 6: FOUNDATION Fieldbus Configuration)
- or others

Limited support for various configuration parameters may apply when using certain configuration tools.

Basic Configuration

The parameters are divided into several categories listed below. Configuration includes specification of parameters for:

- “Antenna” on page 4-3
- “Tank Geometry” on page 4-5
- “Analog Output” on page 4-7
- “Process Conditions” on page 4-9
- “Temperature Measurement” on page 4-9
- “Volume Calculation” on page 4-10

Advanced Configuration

When the basic configuration is done the transmitter will be optimized for your application. However, in some cases the transmitter must be further configured using the Advanced Functions (this may affect the previous basic configuration by updating some parameters already set).

- “Advanced Functions” on page 4-11

ANTENNA

For the antenna a few choices are available. The type of antenna must always be selected and, if applicable, corresponding type of tank sealing to be used. User Defined is for non-standard antennas only.

The following parameters are used:



Hold Off Distance The (UNZ) defines how close to the transmitter's reference point a level value is accepted. Normally, the Hold Off Distance is set automatically and does not need to be changed. However, if there are disturbing echoes in the upper part of the tank, for example from the tank nozzle, you can increase the Hold Off Distance in order to avoid measurements in the region close to the antenna. (See "Setting the Hold Off Distance" on page 2-39).

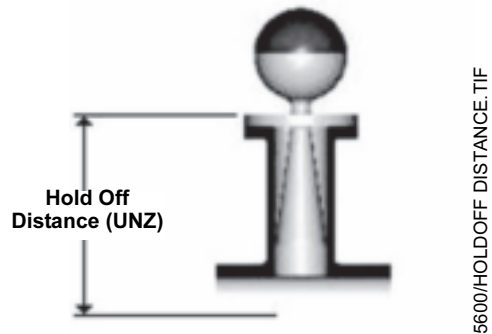

Pipe Inner Diameter The figure is used to compensate for the lower microwave propagation speed inside the pipe. An incorrect value will give a scale factor error. Only valid for pipe antennas or cone antennas in existing still-pipe. If locally supplied still-pipes are used, make sure the inner diameter is noted before installation of the pipe.

Tank Connection Length The (TCL) parameter is entered for antenna type User Defined only. For standard antennas the TCL value is set automatically. For the 500 mm extended cone use the TCL_{ext} values in Table 4-2. (See "Setting the Tank Connection Length (TCL)" on page 2-38).

Table 4-1. Hold Off Distance Default Value inches (millimeters)

Antenna Type	TCL	Hold Off
User Defined	0.000 (0.000)	0.000 (0.000)
Rod 100	23.62 (600)	23.43 (595)
Rod 250	30.83 (780)	29.06 (738)
Cone 3" PTFE	18.70 (475)	4.72 (120)
Cone 4" PTFE	18.70 (475)	6.69 (170)
Cone 6" PTFE	18.70 (475)	11.02 (280)
Cone 8" PTFE	18.70 (475)	15.75 (400)
Cone 3" Quartz	20.28 (515)	4.72 (120)
Cone 4" Quartz	20.28 (515)	6.69 (170)
Cone 6" Quartz	20.28 (515)	11.02 (280)
Cone 8" Quartz	20.28 (515)	15.75 (400)
Pipe with Cone PTFE	18.70 (475)	2.36 (60)
Pipe with Cone Quartz	20.28 (515)	2.36 (60)
Parabolic	31.22 (793)	7.87 (200)
Process Seal 4" PTFE	22.17 (563)	7.87 (200)
Process Seal 6" PTFE	24.53 (623)	7.87 (200)

Table 4-2. TCL_{ext} for standard extended lengths, 500 mm

Sealing	3 inch Cone	4 inch Cone	6 inch Cone
PTFE	0.019 (0.489)	1.90 (0.482)	1.88 (0.477)
Quartz	2.08 (0.529)	2.06 (0.522)	2.04 (0.517)

TANK GEOMETRY

For Tank Geometry the following basic configuration must be performed:

Tank Height (R)

The Tank Height is defined as the distance between the upper reference point (top-side of the tank nozzle) and the lower reference point (zero level).

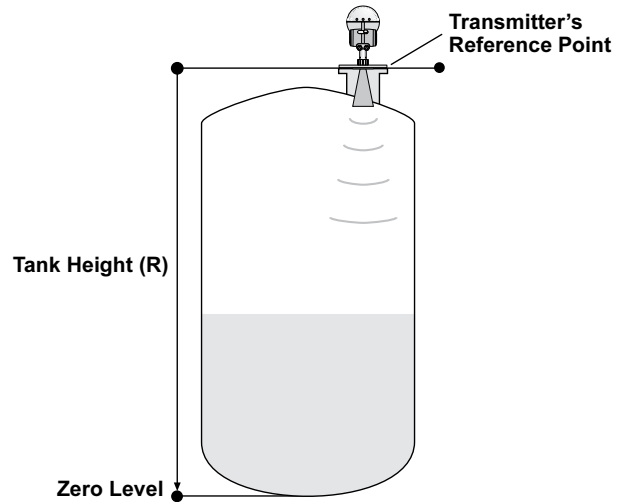

Tank Type
 Tank Bottom Type

By defining Tank Type and Tank Bottom Type default values for some parameters are set. Through this the transmitter is optimized for a specific combination of Tank type and Tank Bottom Type. For tank types vertical cylinder and cubical, all tank bottom types are valid. For tank types horizontal cylinder and spherical, the parameter Tank Bottom Type is not used. Select Tank Bottom Type flat inclined if the bottom inclination is between 10 and 30 degrees. If the inclination is less than 10 degrees but there are disturbing objects on the tank floor (like heating coils) right beneath the transmitter use this selection.

The following combinations of Tank Type and Tank Bottom Type are valid:

Table 4-3. Tank Bottom

Tank Type	Tank Bottom Type
Vertical Cylinder	Flat, Dome, Cone, Flat inclined
Horizontal Cylinder	Not Applicable
Spherical	Not Applicable
Cubical	Flat, Dome, Cone, Flat inclined

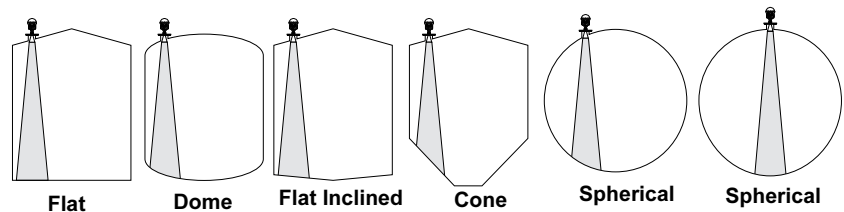

Advanced Tank Geometry Configuration

Advanced configuration is done through the following parameters:

Distance Offset (G)	The Distance Offset (G) is defined as the distance between the upper reference point and the flange (the flange is referred to as the Transmitter's Reference Point). You can use the Distance Offset to specify your own reference point at the top of the tank. Set the Distance Offset to zero if you want the flange as upper reference point. The Distance Offset is defined as positive if you use an upper reference point above the Transmitter's Reference Point. The Distance Offset is used when the measured level by the transmitter should correspond with the level value obtained by hand-dipping.
Minimum Level Offset (C)	The Minimum Level Offset (C) defines a lower null zone which extends the measurement range beyond the Zero Level Reference Point down to the tank bottom. The Minimum Level Offset is defined as the distance between the zero level (Tank Level Reference Point) and the minimum accepted level and tank bottom. Set the Minimum Level Offset to zero if you use the tank bottom as zero level reference point. If the zero level is not defined as the tank bottom and instead is an elevated point as the datum plate, you need to define the Minimum Level Offset. Note: The Minimum Level Offset can not be negative.
Calibration Distance	The Calibration Distance is by default set to zero. It is used to adjust the transmitter so that measured levels match hand dipped product levels. Normally a minor adjustment is necessary. There may for example be a deviation between the actual tank height and the value stored in the transmitter database.
Show Negative Values as Zero	Set this parameter if you want levels below the reference point at the bottom of the tank to be displayed as zero. This parameter can be used if you have set a Minimum Level Offset distance in the tank geometry configuration.

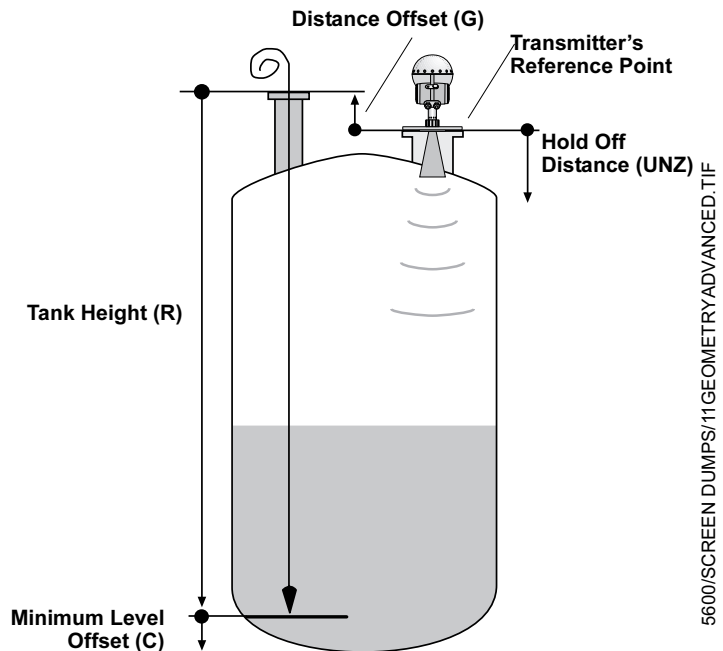

5600/SCREEN DUMPS/11GEOMETRYADVANCED.TIF

ANALOG OUTPUT

The 5600 has the possibility to handle two analog outputs which can be separately configured.

However, if your transmitter is equipped with a primary 4-20 mA HART output, you must use Analog Output 1. (Analog Output 1 is not available for primary output when using other bus communication protocols than HART).

Output Source	Select the source to control the analog output.
Upper Range Value	Enter the range values that correspond to the analog output values 4 and 20 mA. You can specify any values as long as the Upper Range Value is above the Lower Range Value. If the measured value goes beyond the measurement range, the transmitter enters the alarm mode.
Lower Range Value	
Alarm Mode	Choose the desired Alarm Mode. The Alarm Mode specifies the analog output state when a measurement error occurs or when the measured value is out of range. High: the output current is set to 22 mA. Low: the output current is set to 3.8 mA. Freeze Current: the output current is set to the present value at the time when the error occurs. Binary High: the output current is 4 mA under normal conditions. If there is a measurement error, or when the source signal is out of range, the output current is set to 20 mA. Binary Low: the output current is 20 mA under normal conditions. If there is a measurement error, or when the source signal is out of range, the output current is set to 4 mA.
Disable Limit Alarm if Out of Range	If the detected limit is out side the upper or lower limit, setting this parameter suppresses the analog output from going into alarm mode.

Figure 4-1 illustrates how the analog output signal is related to the actual measured product level and the specified upper and lower limits. As illustrated, if the source signal exceeds the Upper limit or falls below the Lower limit, the output current is set according to the specified Alarm Mode settings.

If your transmitter is equipped with an optional analog output (Analog Output 2), configure it as described above.

Figure 4-1. Alarm Mode Settings

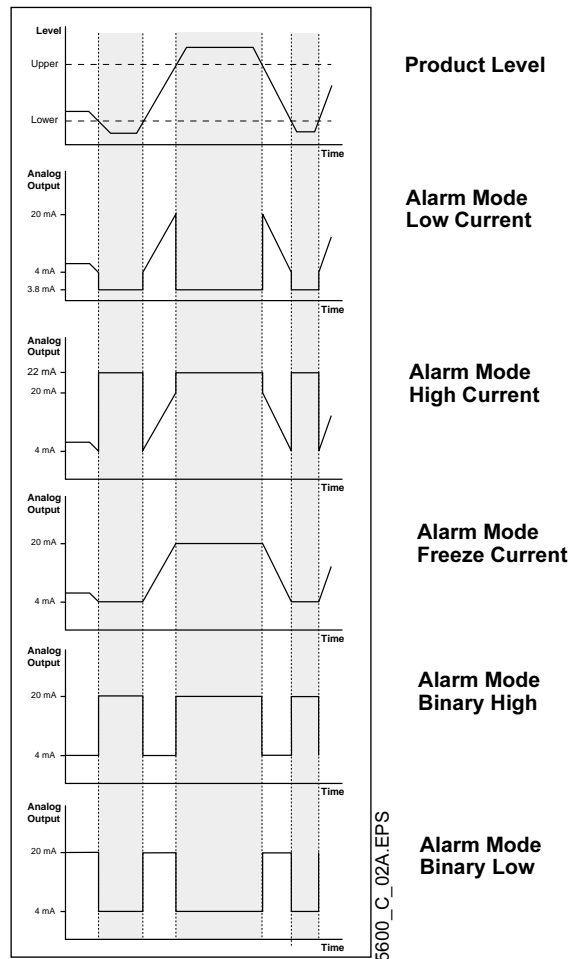

Analog Output current as a function of product level for different alarm mode settings. The shaded area indicates analog output in Alarm mode. The graphs are valid when Disable Limit Alarm if Out of Range is not set.

PROCESS CONDITIONS

Describe the conditions in your tank according to the Process Conditions listed below. For best performance choose only if applicable and not more than two options.

Rapid level changes	Optimize the transmitter for measurement conditions where the level changes quickly due to filling and emptying of the tank. A standard configured transmitter is able to track level changes of up to 4 inch/s (100 mm/s). When the Rapid Level Changes check box is marked, the transmitter can track level changes of up to 8 inch/s (200 mm/s).
Turbulent Surface	This parameter should be used if the tank shows a turbulent surface. The reason for the turbulence might be splash loading, agitators, mixers, or boiling product. Normally the waves in a tank are quite small and cause local rapid level changes. By setting this parameter the performance of the transmitter will be improved when there are small and quickly changing amplitudes and levels.
Foam	Setting this parameter optimizes the transmitter for conditions with weak and varying surface echo amplitudes, which are typical for foam.
Solid Products	Setting this parameter optimizes the transmitter for solid products, for example concrete or grains, which are not transparent for radar signals. For instance, this parameter can be used when the application is a silo with product buildup.

TEMPERATURE MEASUREMENT

Up to six temperature sensors can be connected to the 2210 Display Unit. You can use 1-3 spot elements or 1-6 multiple spot elements. All temperature sensors must be of the same type, for example, the Pt100 or CU90. See "Temperature Measurement" on page 3-14 for information on how to connect the temperature sensors.

Use one of the following temperature measurement conversion methods:

- PT100
- CU90
- User Defined Linearization Table. The sensor characteristics are specified in a table of corresponding resistance and temperature values.
- User Defined Formula. The sensor characteristics are specified in a mathematical formula: $R=R_0 \cdot (1+A \cdot T+B \cdot T^2)$ where R is the resistance at temperature T, R_0 is the resistance at zero degrees Centigrade and A and B are constants.

Sensor Mounting Level 1-6	Enter the level (from the tank bottom) at which each sensor is mounted. The first sensor should be mounted in the lowest position in the tank, the second above the first and so on.
Number of Sensors	Enter the number of temperature sensors connected to the Display Unit. You can have up to six sensors connected. If you choose zero sensors temperature measurement is disabled.

Rosemount 5600 Series

VOLUME CALCULATION

The Volume Calculation is performed by using one of two methods: predefined tank shape or strapping table. The strapping table is an optional function. If this function is required, please contact your local Rosemount representative.

To configure the 5600 transmitter for volume calculations you have to choose a Volume Calculation method.

Select one of the volume calculation methods. Choose one of the ideal tank shape options if approximation of your tank with an ideal tank shape provides sufficient accuracy. The strapping table option can be used for an arbitrary tank shape. You can enter levels and corresponding volumes to obtain a close match between the actual and the calculated volume. This option should be used in cases where the tank shape deviates significantly from an ideal sphere or cylinder, or when you require high accuracy.

NOTE

The transmitter is delivered with a code that enables the ordered software options including strapping table volume calculation. If you wish to change the set of available options, contact your local Rosemount representative.

Ideal Tank

Use this option if approximation of your tank with an ideal tank shape (assuming no dished ends) provides sufficient accuracy. Enter the following parameters:

- Tank Diameter (and the length if it is a horizontal tank).
- Volume Offset: Use this parameter if you do not want zero volume and zero level to match (for example if you want to include volume below the zero level).

Strapping Table

- Enter levels and corresponding volumes starting at the bottom of the tank. These figures can typically be obtained from tank drawings or from certificate from the tank manufacturer. If the level//volume table is based on a reference point that is different from your reference point, you can use Level Offset and Volume Offset. The Volume Offset is added to every value in the corresponding column.
- Select which interpolation method to use for calculating volumes between the strapping points. Normally, linear interpolation is the preferred method. For spherical tanks, quadratic interpolation may result in a smaller error. By using linear interpolation and a sufficient number of values in the strapping table, the interpolation error can normally be reduced to a minimum.

ADVANCED FUNCTIONS

In some cases the transmitter must be further configured using the Advanced Functions. Please note this may affect the previous basic configuration by updating some parameters already set.

Disturbance Echo Handling

There are three methods available for Disturbance Echo Handling:

- General Amplitude Threshold
- Customized Noise Threshold Table (Amplitude Threshold Points [ATP] table)
- Registration of False Echoes

There are guidelines on when to register a false echo and what the Auto Configuration does.

Figure 4-2. Disturbance Echoes

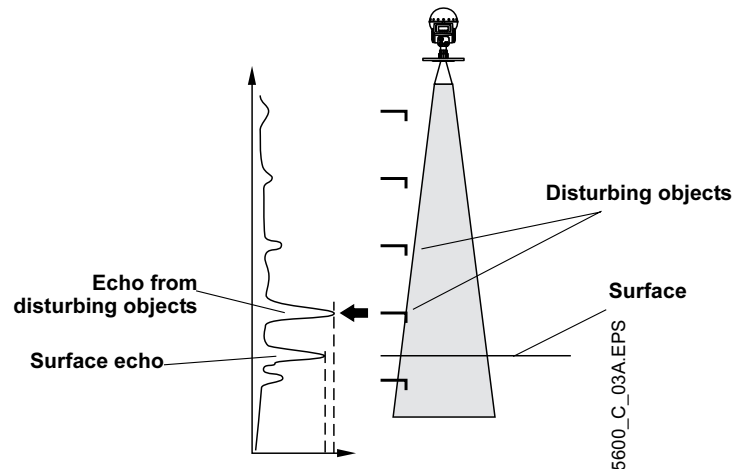

The False Echo function is used to improve the performance of the transmitter when the surface is close to a horizontal surface of a stationary object in the tank. The object causes an echo when it is above the surface. When the echoes from the surface and the object are close to each other, they might interfere and cause a decrease in performance.

It is possible to store the positions of the disturbing objects in the memory of the transmitter. When the surface is passing by a disturbing object, the transmitter can measure with a higher reliability, when the position of the object is registered.

Use a spectrum plot to find the disturbance echoes. Remember to update it several times to get the whole picture of disturbance echoes in the tank. Do not base the false echo registration on only one updated spectrum plot. (See Figure 4-3).

Figure 4-3. Spectrum plot for typical calm conditions

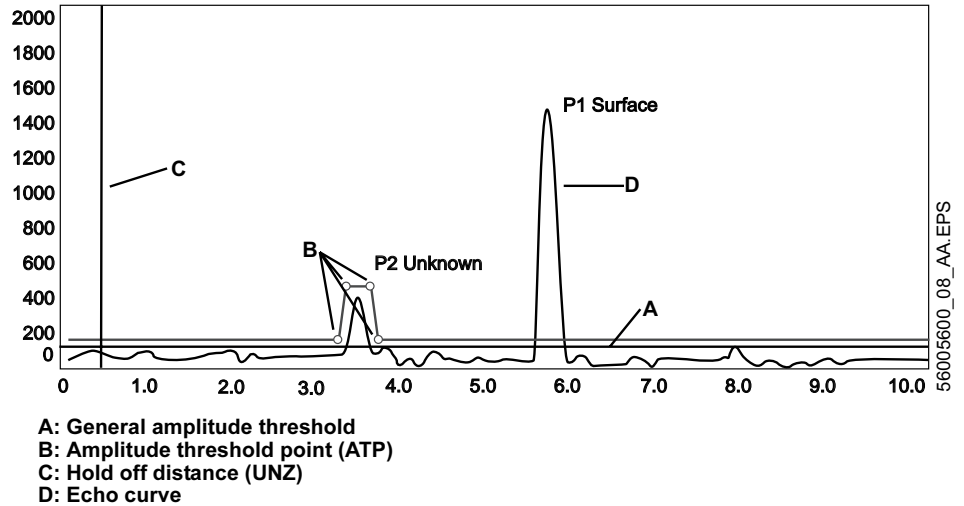

General Amplitude Threshold	<p>Echoes with amplitudes below the general amplitude threshold will be disregarded. Recommended threshold values are:</p> <ul style="list-style-type: none"> • Calm conditions: no turbulence, foam or condensation. Set amplitude threshold to approximately 20% of surface echo amplitude. • Foam, agitators, or low product DC: the surface echo signal may drop to 200-300 mV during processing in tank. A threshold value of about 150 mV is recommended. <p><i>Note:</i> <i>These figures are estimations. Significantly different figures may have to be used in many cases.</i></p> <p>Some further considerations are:</p> <ul style="list-style-type: none"> • If water test is performed before the product enters the tank, there is probably a difference in signal amplitude between the water and the product. Use the signal amplitude for the product to set the amplitude threshold. • A moving surface may cause a decrease in signal amplitude.
-----------------------------	--

Customized Noise Threshold Table (ATP-table)	<p>You can filter out weak disturbing echoes by creating a noise threshold table. This technique should only be used in special situations, for example at the bottom of tanks with weak disturbing echoes. In such tanks the transmitter may lock at disturbances close to the bottom when the tank is empty. Setting up a noise threshold in the region will guarantee that the transmitter starts following the surface when the tank is filled again. Make sure the surface echo amplitude in the bottom region is always stronger than the noise threshold. (See Figure 4-4)</p> <p>Also, this function can be used in areas where occasionally there are strong echoes present. For those large areas registering a False Echo may not be sufficient.</p> <p>Furthermore, the ATP-table can be used to remove influence for the tank nozzle or a still-pipe inlet at the top of the tank. The Hold Off Distance (UNZ) can also be used to manage such cases.</p> <p>Do not create noise thresholds around echoes which are already registered as interfering echoes. The general amplitude threshold is the lower limit of the noise threshold table. (See Figure 4-4).</p>
Registration of False Echoes	<p>The False Echo function allows you to let the transmitter register disturbing echoes caused by objects in the tank. This makes it possible to detect a product surface close to a disturbance echo even if the surface echo is weaker than the disturbing echo. (See Figure 4-5).</p> <p>When should I register?</p> <p>See the following recommendations before you register new interfering echoes:</p> <ul style="list-style-type: none">• Make sure that a correct amplitude threshold is set before you register any disturbance echoes. See description of the SpectraThreshold window.• Keep the number of registered echoes to a minimum.• Compare the list of interfering echoes with the tank drawing or by visible inspection of the tank. Note if there are objects like beams, heating coils, agitators, etc. which correspond to the found echoes. Only register echoes which can be clearly identified as objects in the tank.• Make sure that the level is stable before you register a disturbance echo. A fluctuating level may indicate a temporary disturbance which is not due to an interfering object.• Do not register a disturbance echo if the amplitude is significantly smaller than the amplitude of the surface echo when the surface is at the same level as the disturbance. (In some cases weak disturbance echoes can be filtered out by creating a noise threshold table.• It may be necessary to register new disturbance echoes at a later stage when objects have become visible due to surface movement.

Figure 4-4. Noise threshold

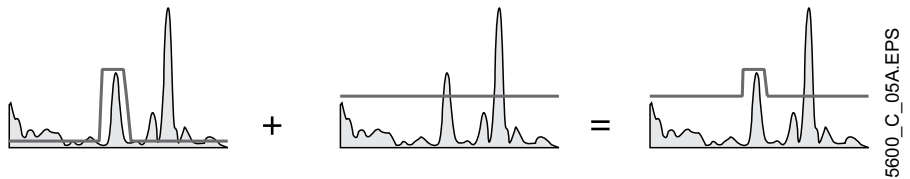
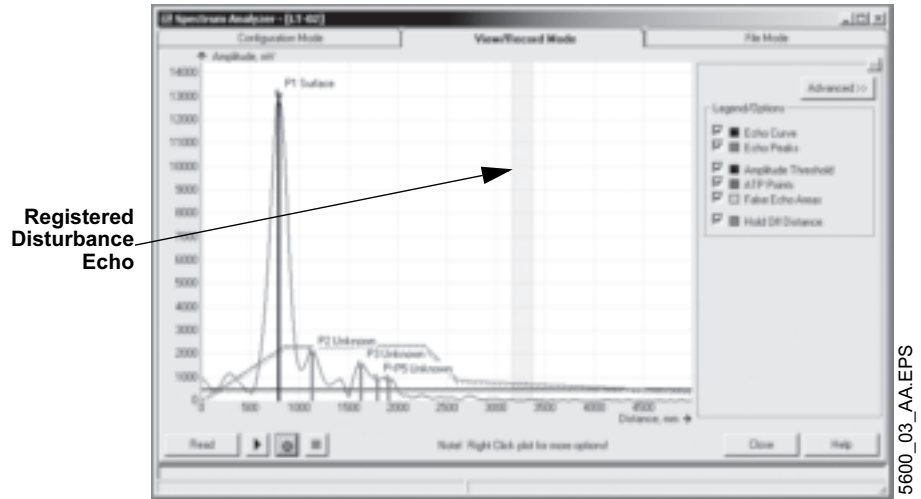

Figure 4-5. False Echoes



Bottom Echo Handling

Bottom Echo Visible

This parameter is automatically set depending on tank type and tank bottom type. By setting this parameter the bottom echo will be treated as a disturbance echo to facilitate tracking of weak surface echoes close to the tank bottom. If this parameter is not set searching for a lost surface echo is restricted to a region close to the tank bottom. Only set this parameter if the bottom echo is visible

The figure shows scenarios (checked tanks) where the bottom echo is visible. Always check if the transmitter shows a value for the bottom at empty tank before marking the checkbox. Only flat bottom tanks have checkbox marked as default. Set this parameter in Advanced Service.

If Empty Tank Handling is set to automatic, the choice of Tank Bottom Type controls the setting of Bottom Echo Visible. For Tank Bottom Type flat, the Bottom Echo Visible parameter is always set.

If the Empty tank Handling function is not set to automatic, the Bottom Echo Visible parameter is set manually for all tank types. However, the Tank Bottom Type flat always has Bottom Echo Visible set.

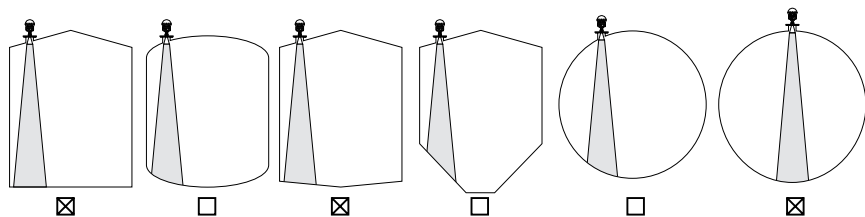

Invalid Level Alarm Is Not Set If Tank Is Empty

If the surface echo is lost close to the bottom of the tank, setting this parameter suppresses the "invalid" display.

Full Tank Handling

Invalid Level Alarm Is Not Set If Tank Is Full

If the surface echo is lost close to the top of the tank, the level value will normally be displayed as "invalid". Set this parameter to suppress the "invalid" display.

Note

By setting this parameter the analog output will not enter alarm mode for invalid levels close to the tank bottom or close to the antenna.

Empty Tank Handling

Empty Tank Detection Area

The Empty Tank Handling is a function for handling situations when the surface echo is lost close to the bottom. If the surface echo is lost the function makes the transmitter present a zero-level measurement, and an alarm is created, unless this alarm has been blocked.

This function is activated by default if you have selected one of the following Tank Bottom Types: Cone, Dome, Flat Inclined, or Unknown. This function also requires that the Bottom Echo Visible checkbox is not marked. If it is marked the function is disabled.

The transmitter will search for the surface echo within the Empty Tank Detection Area. The Empty Tank Detection Area is calculated as a percentage of Tank Height (R) + Minimum Level Offset (C) - Distance Offset (G). It has a lower limit of 400 mm and a higher limit of 1000 mm. Used Empty Tank Detection Area is shown in Advanced Setup and can be adjusted manually if required.

Since the transmitter will search for the surface echo in the Empty Tank Detection Area, it is important that there are no disturbances in this area. If there are disturbances it may need to be filtered out. (See "Disturbance Echo Handling" on page 4-11 and "Tank Geometry" on page 4-5.

Surface Tracking

Slow Search	This variable controls how to search for the surface if a surface echo is lost. With this parameter set the transmitter starts searching for the surface at the last known position, and gradually increases the width of the search region until the surface is found. If this variable is not set the transmitter searches through the whole tank. This parameter may typically be used for tanks with turbulent conditions.
Slow Search Speed	If the surface echo is lost, the transmitter starts to search around the last known level to find the surface echo again. This parameter indicates how fast it should expand the search window.
Double Surface	Indicates that there are two liquids or foam in the tank resulting in two reflecting surfaces. The upper liquid or foam layer must be partly transparent to the radar signal. If this function is activated, you can specify which surface to select by using the Select Lower Surface parameter.
Upper Product DC	This is the dielectric constant for the upper product. A more precise value results in better accuracy for the lower surface level.
Level above min distance possible	If the surface echo is lost in the vicinity of the antenna, full tank is indicated and searching for the surface echo is limited to a region close to the antenna.
Select Lower Surface	This function should only be used if Double Surface is set. If Select Lower Surface is set the lower surface will be presented as the product surface. If not set the upper surface is tracked.
Echo Timeout	Use Echo Timeout to define the time in seconds before the transmitter will start to search for a surface echo after it has been lost. After an echo has been lost, the transmitter will not start searching or set Invalid Level until this time has elapsed.
Close Distance Window	This parameter defines a window centered at the current surface position in which new surface echo candidates can be selected. The size of the window is \pm CloseDist. Echoes outside this window will not be considered as surface echoes. The transmitter will immediately jump to the strongest echo inside this window. If there are rapid level changes in the tank, the value of the Close Distance Window could be increased to prevent the transmitter from missing level changes. On the other hand, a value too large might cause the transmitter to select an invalid echo as the surface echo.

Double Bounce Possible

Some radar waves are reflected against the tank roof and back to the surface before they are detected by the transmitter. Normally, these signals have a low amplitude and are therefore neglected by the transmitter. For spherical and horizontal cylinder tanks, in some cases the amplitude may be strong enough to lead the transmitter to interpret the double bounce as the surface echo. By setting the Double Bounce parameter this type of measurement situation may be improved. **This function should only be used if the problem of double bounces can not be solved by changing the mounting position.**

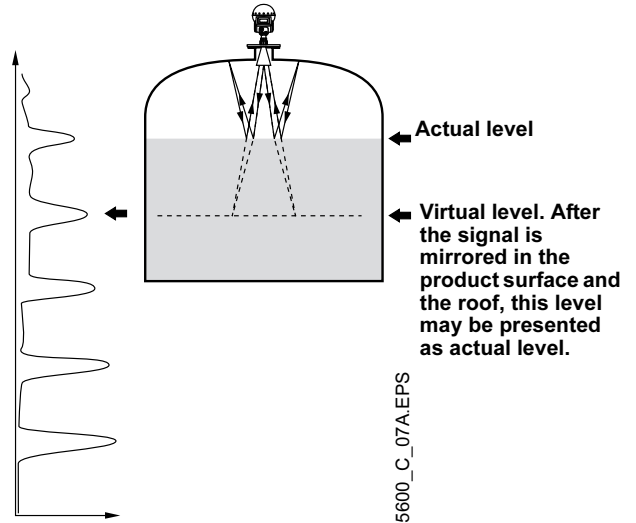

Double Bounce Offset

Use the Double Bounce Offset to define the distance between detected double bounces. In order to determine the Double Bounce Offset, you need to check the spectra of signal amplitude vs. distance to echo or read the detected echoes from the display. The distance between double bounces is constant. By subtracting two times the distance to the surface level (2A) from the distance to the first double bounce (B) you will get the Double Bounce Offset. The Double Bounce Offset is negative if the reflection point (normally the tank roof) is below the transmitter's reference point.

$$DBO = B - 2A$$
 DBO: Double Bounce Offset
 B: Distance to first double bounce
 A: Distance to surface

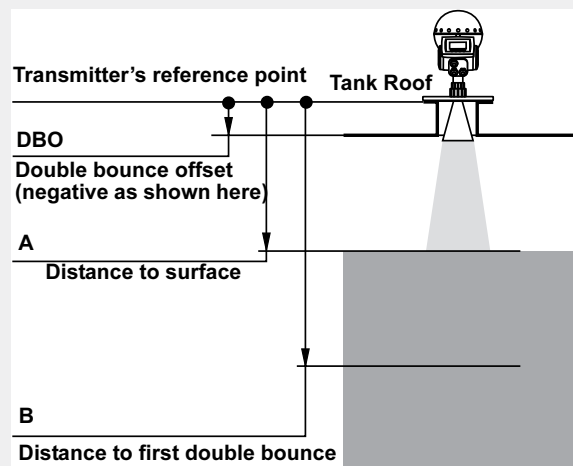

Filtering

Distance Filter Factor	The Distance Filter Factor defines how much the level value should be filtered. A low factor setting will give the new level value by adding a small portion (for instance 1%) of the level change to the previous level value. A high factor setting typically takes the latest measurement and presents it as the new level. This implies that a low factor setting makes the level value steady but the transmitter reacts slower to level changes in the tank. A high factor setting makes the transmitter react quickly to level changes but the level value can be somewhat jumpy.
Activate Jump Filter	If the surface echo is lost and a new surface echo is found, the Jump Filter tells the transmitter to wait for some time before it jumps to the new echo. During that time the new echo has to be a valid echo. The Jump Filter does not use the Distance Filter Factor and can be used in parallel to the Least Square Filter or the Adaptive Filter. The Jump Filter is typically used for applications with turbulent surface and makes the echo tracking work smoother as the level passes the agitator.
Activate Least Square Filter	This filter calculates the new level value according to the least square method and will give increased accuracy for slow filling or emptying of tanks. The level value will follow the surface with high accuracy and without delay as the level changes. When the level stabilizes at a certain level, the Least Square Filter makes the level move somewhat further before it aligns to the correct level value.
Activate Adaptive Filter	The Adaptive Filter is tracking the level fluctuations, and is continuously adjusting the filter grade accordingly. The filter can preferably be used in tanks where fast tracking of level changes are important, but where turbulence occasionally cause unstable level values.

Rosemount 5600 Series

Reference Manual
00809-0100-4024, Rev BA
September 2005

Section 5 HART Configuration

HART

Safety Messages	page 5-1
Overview	page 5-1
Safety Messages	page 5-1
Hand-Held Communicator	page 5-7

SAFETY MESSAGES

Procedures and instructions in this section may require special precautions to ensure the safety of the personnel performing the operations. Information that raises potential safety issues is indicated by a warning symbol (⚠). Please refer to the following safety messages before performing an operation preceded by this symbol.

⚠ WARNING

Explosions could result in death or serious injury:

Verify that the operating environment of the transmitter is consistent with the appropriate hazardous locations certifications.

Before connecting a HART-based communicator in an explosive atmosphere, make sure the instruments in the loop are installed in accordance with intrinsically safe or non-incendive field wiring practices.

Do not remove the transmitter cover in explosive atmospheres when the circuit is alive.

OVERVIEW

The Rosemount 5600 Radar Level Transmitter uses AMS Suite™ as a configuration tool. Access <http://www.emersonprocess.com/ams/> for literature related to configuring the Rosemount 5600 Radar Level transmitter.

Rosemount 5600 Series

PC CONFIGURATION SOFTWARE RADAR MASTER

The Rosemount Radar Master is an interactive and powerful configuration tool that assists you in properly setting up a Rosemount 5600 for the application it is mounted on. This tool is shipped with every order and offers assistance for users of all levels, from beginners to more experienced users. The Installation Wizard guides you through a basic setup including the necessary steps to get a straight forward application up and running. Other sections in the software allows for a custom setup and includes features such as:

- An extensive on-line help, eliminating the need for a manual in paper. This on-line help is not only a description of the software itself but also includes guidelines of how to configure the transmitter.
- Off-line installation, for configuration and setup of transmitters that have not been physically installed or powered up.
- A Spectrum Plot describes the situation and conditions in the tank the way the transmitter views them.
- Logging features is where you can log measured data and other relevant data.
- Use the Advanced setup support for your more difficult applications.

Installation

The program on the CD will automatically start and suggest an installation of the Radar Master software. You will need to restart your PC prior to running the Radar Master program.

NOTE

For Windows 2000 and Windows XP you need to set the Serial Port buffers to 1. Follow the instructions below:

1. Right click on My Computer and choose Properties.
2. Choose the tab Hardware.
3. Click on the button Device Manager.
4. Navigate to Ports in the list of hardware.
5. Right click on Serial Port COM 1 and choose Properties.
6. Choose the tab Port Settings.
7. Click Advanced.
8. Drag the slider for Receive Buffer and Transmit Buffer to 1.
9. Click OK.
10. Reboot the Computer.
11. Repeat for COM 2 if available.

Start the Radar Master

1. From the Start menu click Programs > Saab Rosemount > Rosemount Radar Master or click the RRM icon in the Windows workspace. Now RRM searches for the transmitter.
2. When the transmitter is found press Yes to connect. If communication does not work check that the correct COM port is connected on the computer and that the COM port is properly configured.
3. In the Radar Master Status Bar verify that RRM communicates with the transmitter (see Figure 5-1).

Figure 5-1. On-line vs. Off-line
Connection to device

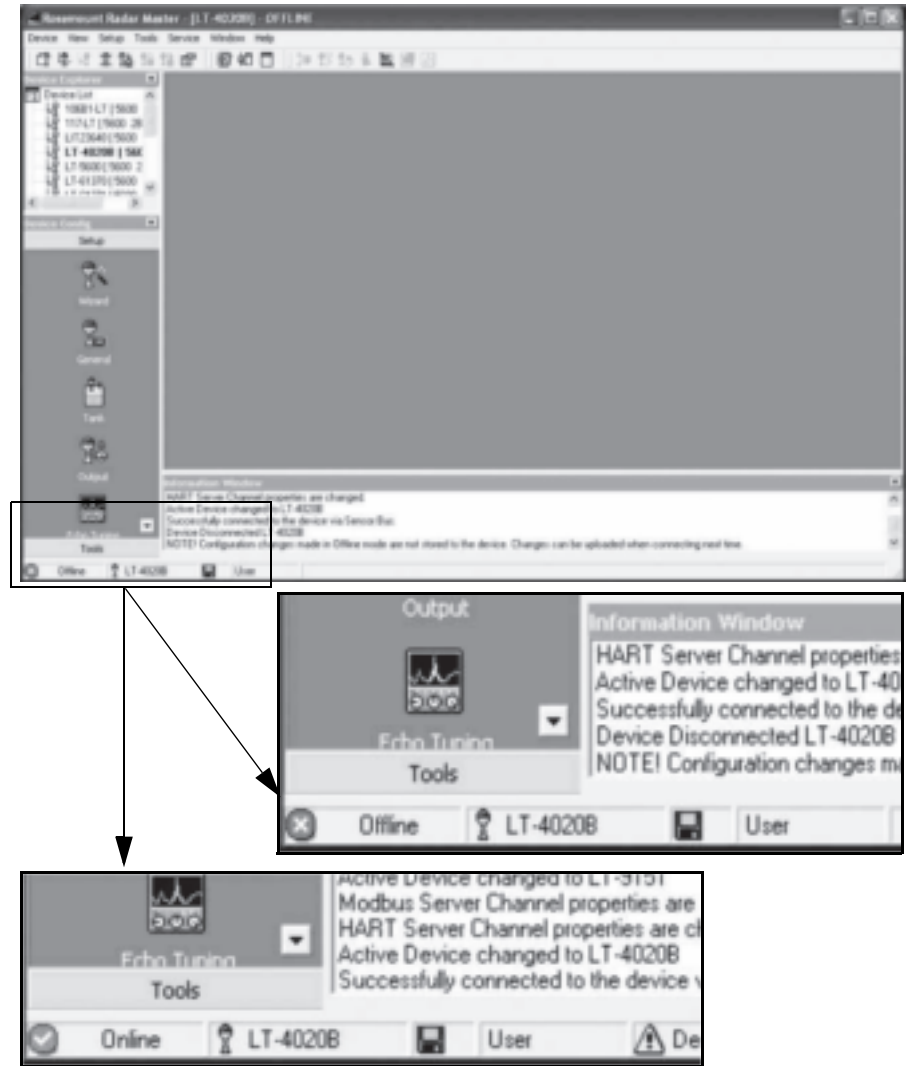

HART

Rosemount 5600 Series

HART

Main Configuration Icons

Figure 5-2. Device Configuration Icons

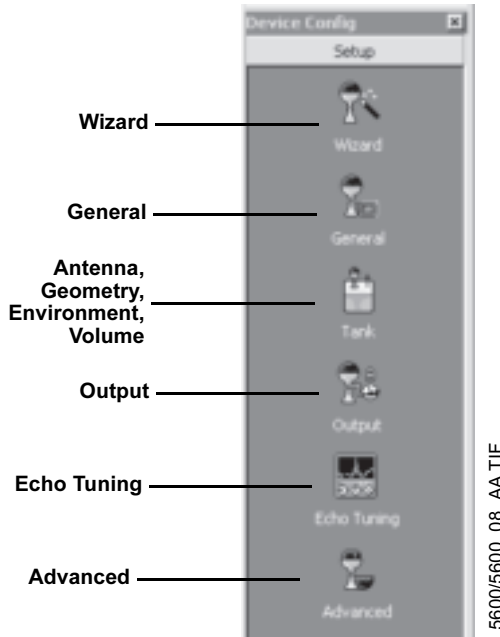

Wizard

Guided setup including the basic configuration settings such as the HART Tag, Antenna Type, Tank Geometry, Variable assignments, Volume, etc.

General

Here you configure the Units settings to work with, HART Tag and descriptors, Remote display Units, etc.

Figure 5-3. General Configuration



Tank

This icon allows you to configure Antenna Type, set the Geometry settings for the tank, Environment settings, and Volume if applicable.

Figure 5-4. Radar Master Tank Configuration

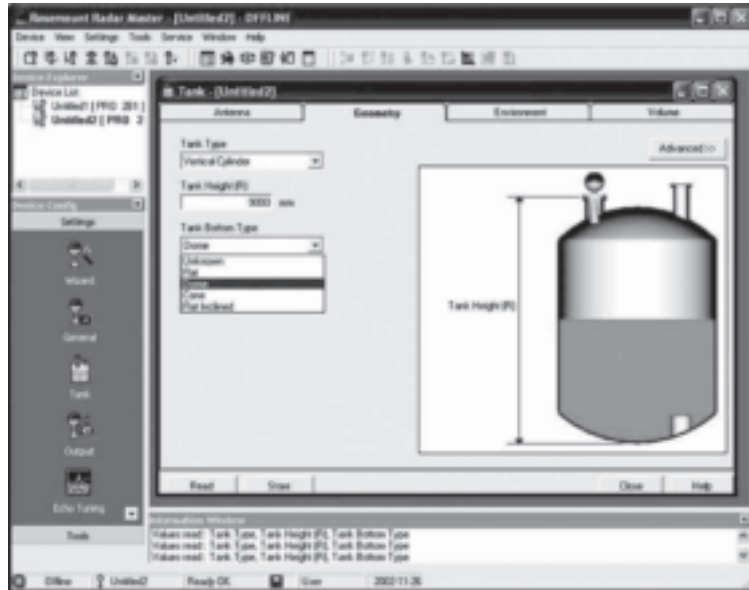

5600/MAINWINDOWS WITH TANKGEOMETRY.TIF

Output

This is the Icon that handles the Analog Outputs and Variable assignments as well as Temperature sensor configuration.

Figure 5-5. Output Configuration

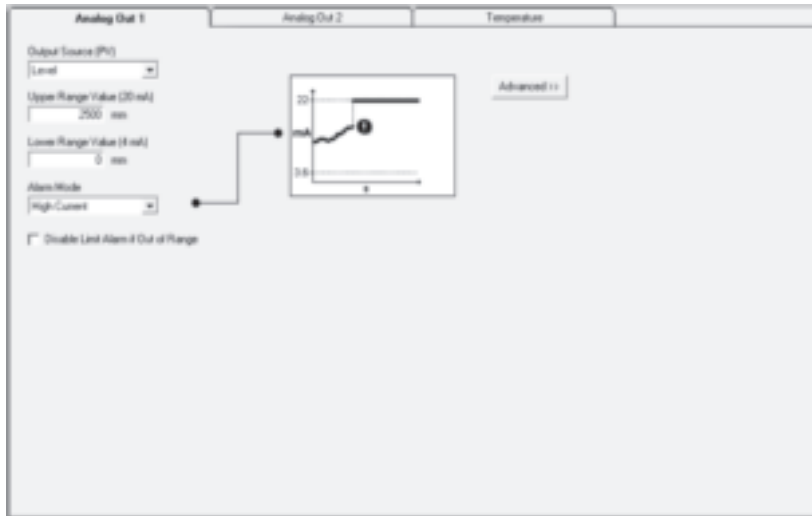

5600_10_AA.TIF

Rosemount 5600 Series

HART

Echo Tuning

This window opens up the Tank Spectrum picture for echo tuning of Disturbance echoes, setting Noise Thresholds, etc.

Figure 5-6. Radar Master Echo Tuning

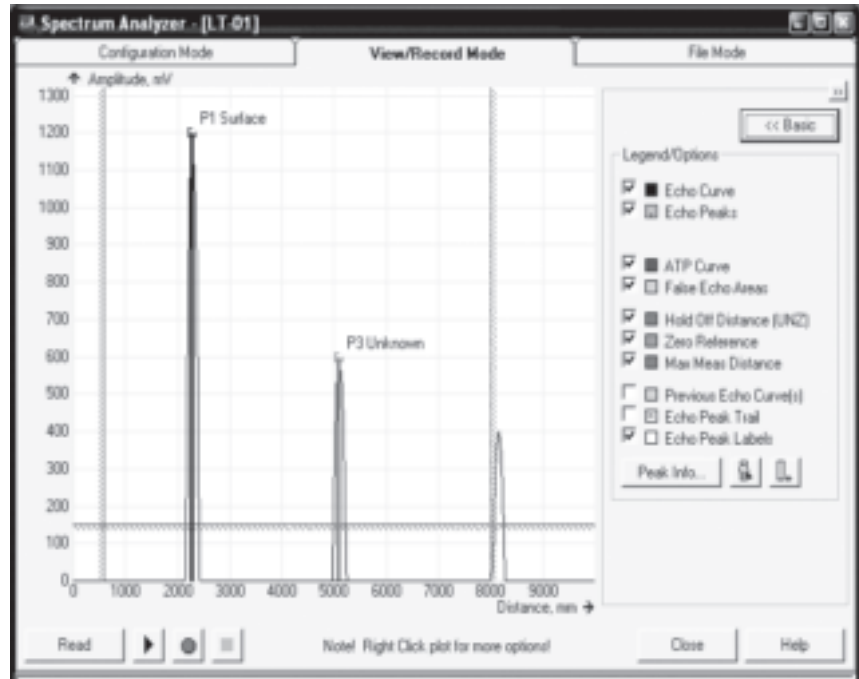

5600/ECHO TUNING.TIF

Advanced

This icon gives you access to advanced configuration functions. Many are automatically set based on Tank Geometry and Environment settings, but for some tough applications the user can manually edit the settings if needed. Examples are Surface echo tracking functions, Empty tank handling, Filtering etc.

Figure 5-7. Advanced Configuration



56005600_11_AA.TIF

HAND-HELD COMMUNICATOR

Commissioning consists of testing the transmitter and verifying transmitter configuration data. The 5600 Series can be commissioned either before or after installation.

To commission, connect the transmitter and the Communicator. Make sure the instruments in the loop are installed according to intrinsically-safe or nonincendive field wiring practices before connecting a communication in an explosive atmosphere. Connect Communicator leads at any termination point in the signal loop.

To enable communication, a resistance of at least 250 ohms must be present between the Communicator loop connection and the power supply. Do not use inductive-based transient protectors with the 5600 Series.

When using a hand-held Communicator, any configuration changes made must be sent to the transmitter by using the “Send” key (F2). AMS configuration changes are implemented when the “Apply” button is clicked. See Figure 3-7, Figure 3-8, Figure 3-9, and Figure 3-10 on page 3-8 to connect the Communicator and transmitter.

For more information on the 275 HART Communicator see document 00275-8026-0002 and for the 375 Field Communicator see document 00375-0047-0001.

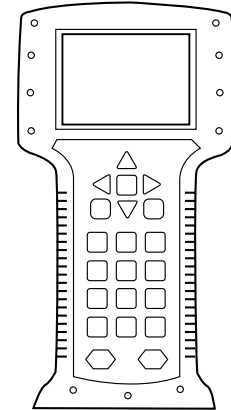

HART

Figure 5-8. HART Communicator Menu Tree for the Rosemount 5600 Radar Level Transmitter

HART

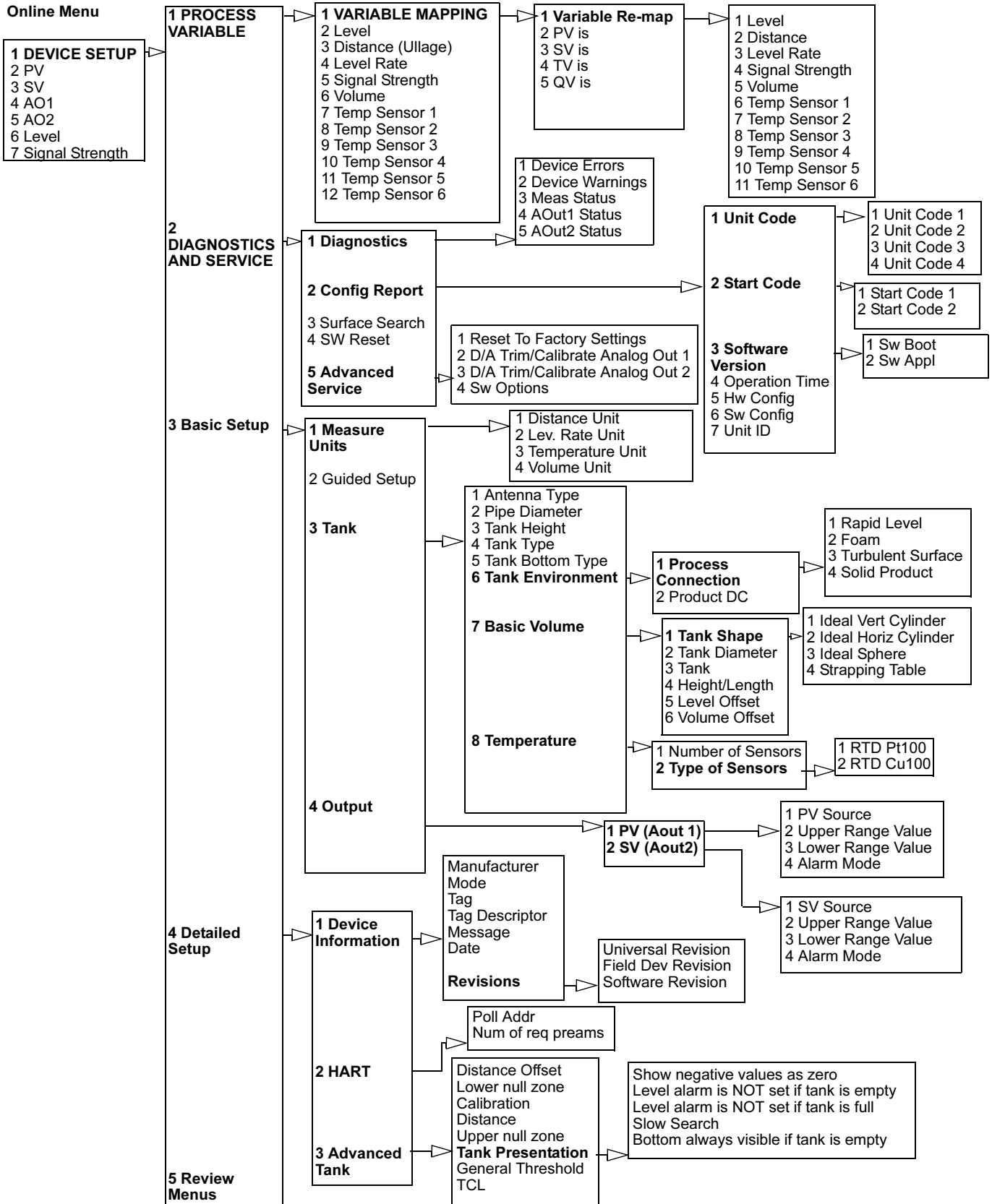

Rosemount 5600 Series

HART

HART Fast Keys

Function	HART Fast Key
Antenna Type	1, 3, 3, 1
Basic Volume	1, 3, 3, 7
Device Information	1, 4, 1
Diagnostics	1, 2, 1
Distance Unit	1, 3, 1, 1
Poll Address	1, 4, 2, 1
Primary Variable	1, 1, 1, 1
PV Alarm Mode	1, 3, 4, 1, 4
PV Lower Range Value	1, 3, 4, 1, 3
PV Upper Range Value	1, 3, 4, 1, 2
PV Source (Assignment)	1, 3, 4, 1, 1
Software Version	1, 2, 2, 3
Surface Search	1, 2, 3
Tank Height	1, 3, 3, 3
Temperature	1, 3, 3, 8

Setting the Loop to Manual

Whenever sending or requesting data that would disrupt the loop or change the output of the transmitter, set the process application loop to manual. The HART Communicator will prompt you to set the loop to manual when necessary. Acknowledging this prompt does not set the loop to manual. The prompt is only a reminder; set the loop to manual as a separate operation.

Connections and Hardware

The HART Communicator exchanges information with the Rosemount 5600 from the control room, the instrument site, or any wiring termination point in the loop. The HART Communicator should be connected in parallel with the transmitter. Use the loop connection ports on the rear panel of the HART Communicator. The connections are non-polarized.



Do not make connections to the serial port or NiCad recharger pack in an explosive atmosphere.

Rosemount 5600 Series

Using a Hand Held Communicator

Level Configuration Example

NOTE

Remember, when using a hand held communicator, you must **send** the data before configuration changes will take effect.

To configure the Rosemount 5600 to report LEVEL (analog output is linear to level) with the transmitter wired as on page 3-6, connect the hand-held communicator as shown.

Set Transmitter Units

HART Comm	1, 3, 1
-----------	---------

Set transmitter units:

- ft
- m
- in
- cm
- mm

Set Reference Transmitter Height

HART Comm	1, 3, 3, 3
-----------	------------

When setting the Reference Transmitter Height, keep in mind that this value is used for all measurements performed by the Rosemount 5600.

Set PV 4 and 20 mA Points

HART Comm	1, 3, 4, 1
-----------	------------

When setting the range values, it is possible to enter the values directly, or to use actual values.

NOTE

The primary variable must be set to *level* (factory default).

Section 6 FOUNDATION Fieldbus Configuration

Introduction	page 6-1
Assigning Device Tag and Node Address	page 6-3
Configure Transmitter using Delta V	page 6-3
Configure the AI Block	page 6-10
Application Examples	page 6-13
Configuration Using the Sensor Bus Port	page 6-16

INTRODUCTION

Figure 6-1 illustrates how the signals are channelled through the transmitter.

Figure 6-1. Function Block Diagram for the Rosemount 5600 Radar Transmitter with FOUNDATION fieldbus

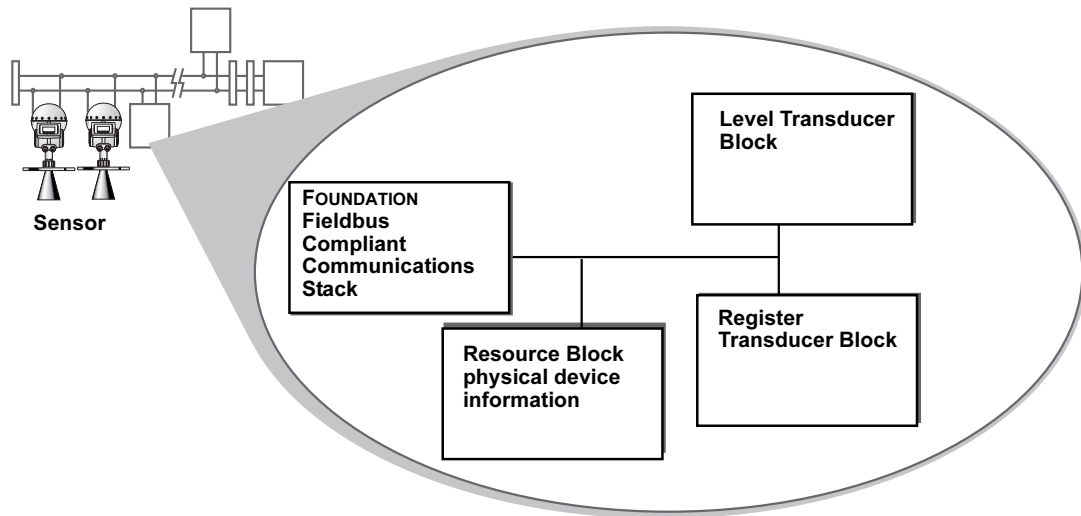

CAUTION

It is highly recommended that you limit the number of periodic writes to all static or non-volatile parameters such as HI_HI_LIM, LOW_CUT, SP, TRACK_IN_D, OUT, IO_OPTS, BIAS, STATUS_OPTS, SP_HI_LIM, and so on. Static parameter writes increment the static revision counter, ST_REV, and are written to the device's non-volatile memory. Fieldbus devices have a non-volatile memory write limit. If a static or non-volatile parameter is configured to be written periodically, the device can stop its normal operation after it reaches its limit or fail to accept new values.

Rosemount 5600 Series

Overview

Each FOUNDATION fieldbus configuration tool or host device has a different way of displaying and performing configurations. Some will use Device Descriptions (DD) and DD Methods to make configuration and displaying of data consistent across host platforms. Since there is no requirement that a configuration tool or host support these features, this section will describe how to reconfigure the device manually.

This section covers basic operation, software functionality, and basic configuration procedures for the Rosemount 5600 Radar Transmitter with FOUNDATION fieldbus (Device Revision 1). For detailed information about FOUNDATION fieldbus technology and the function blocks used in the Rosemount 5600 transmitter, refer to the FOUNDATION fieldbus Block manual (00809-0100-4783).

FOUNDATION Fieldbus Function Blocks

Resource Block

The Resource block contains diagnostic, hardware, electronics, and mode handling information. There are no linkable inputs or outputs to the Resource Block. See Appendix D: Resource Block for additional information.

Transducer Block

The Transducer block allows a user to view the different parameters, errors, and diagnostics in the transmitter. It also includes information to configure the transmitter for the application it is used in. Refer to the FOUNDATION fieldbus Block manual (00809-0100-4783) for additional information.

Level Transducer Block

The Level Transducer block contains transmitter information including diagnostics and the ability to configure the radar transmitter, set to factory defaults, and restart the transmitter. See Appendix C: Level Transducer Block for additional information.

Register Transducer Block

The Register Transducer Block allows a service engineer to access all database registers in the device. See Appendix E: Register Transducer Block for additional information.

Analog Input (AI) Block

The Analog Input (AI) function block processes field device measurements and makes them available to other function blocks. The output value from the AI block is in engineering units and contains a status indicating the quality of the measurement. The measuring device may have several measurements or derived values available in different channels. Use the channel number to define the variable that the AI block processes and passes on to linked blocks. See “Configure the AI Block” on page 6-10 for additional information.

Figure 6-2. Analog-Input Block

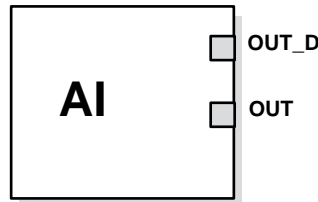

OUT=The block output value and status
OUT_D=Discrete output that signals a selected alarm condition

FIELDBUS-FBUS_31A

ASSIGNING DEVICE TAG AND NODE ADDRESS

The Rosemount 5600 is shipped with a blank tag and a temporary address (unless specifically ordered with both) to allow a host to automatically assign an address and a tag. If the tag or address need to be changed, use the features of the configuration tool. The tools basically do the following:

1. Change the address to a temporary address (248-251).
2. Change tag to new value.
3. Change address to new address.

When the device is at a temporary address, only the tag and address can be changed or written to. The resource, transducer, and function blocks are all disabled.

CONFIGURE TRANSMITTER USING DELTA V

The Rosemount 5600 Radar Transmitter with FOUNDATION fieldbus software is designed to permit remote testing and configuration using the Emerson Process Management DeltaV™ fieldbus configuration tool, or other FOUNDATION fieldbus host.

NOTE

Device support files for the Rosemount 5600 Radar Transmitter with Foundation fieldbus are available on www.rosemount.com. Correct revision of Device Support Files must be loaded into DeltaV to provide proper functionality.

1. Select **DeltaV > Engineering > DeltaV Explorer** from the Start menu.
2. Navigate through the file structure to find the transmitter you wish to configure.
3. The **Fieldbus Device Properties** window appears (see Figure 6-3).

Rosemount 5600 Series

Figure 6-3. Fieldbus device properties



4. Enter a description of the device properties information in the window.

CONFIGURE THE PARAMETERS

The wizard is used to do a standard configuration of the device. All settings that are made from this method can also be made manually from the DD information, through the parameters listed below.

Figure 6-4. List of Function Blocks in **DeltaV Explorer**

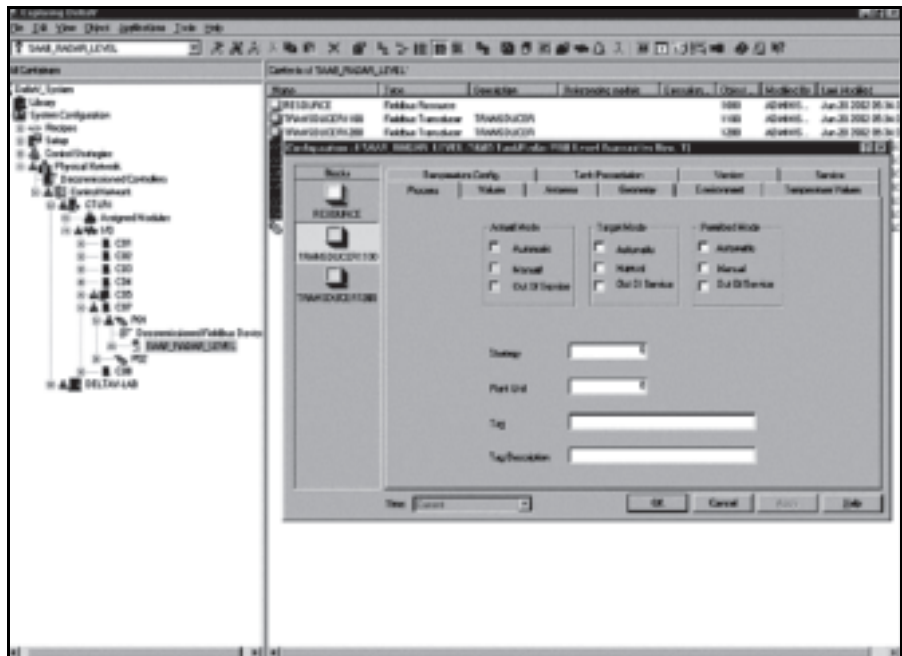

5600_D_01A.TIF

FOUNDATION Fieldbus

1. Double click on the TRANSDUCER1100 block icon. The transducer block properties window appears.
2. Select the **Mode** tab.
3. Select Out of Service (**OOS**) and deselect **Auto** in the **Target Mode** region of the window.

The parameters you change in the properties window remain highlighted so you can easily track changes.

4. Click the **Apply** button to apply the changes you made.

The software warns you that the changes you made may upset the process and create a dangerous situation in your plant. Before you select **OK**, verify that the control loop is in manual control.

The **Actual Mode** region changes to **OOS**.

5. A warning window will pop up, click **OK** to return to the DeltaV Explorer.
6. Right click on the TRANSDUCER block icon to access the configuration parameters menu.
7. Select the parameter you wish to configure, and follow the on-line instructions to complete the configuration.

NOTE

As you make changes to the configuration parameters, the software warns you that the changes you made may upset the process and create a dangerous situation in your plant. Before you select **OK**, verify that the control loop is in manual control.

See Appendix C: Level Transducer Block to change the sensor type and to calibrate the sensors.

8. Repeat Steps 1 through 5 to return the mode of the transducer block to **Auto**.

Process

Figure 6-5. Configuring the Rosemount 5600 Transducer Block (Process Tab)



5600_F_01A.TIF

Rosemount 5600 Series

Values

Figure 6-6. Configuring the Rosemount 5600 Transducer Block (Values Tab)

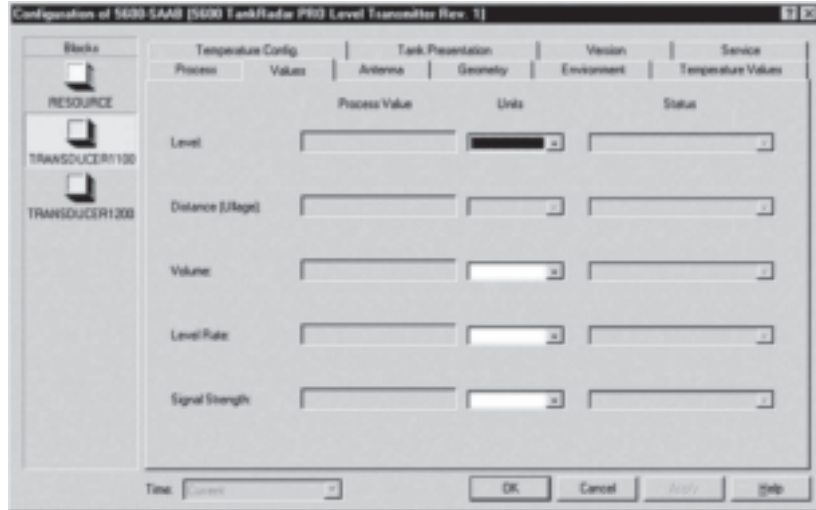

5600_J_01A.TIF

Antenna

Figure 6-7. Configuring the Rosemount 5600 Transducer Block (Antenna Tab)

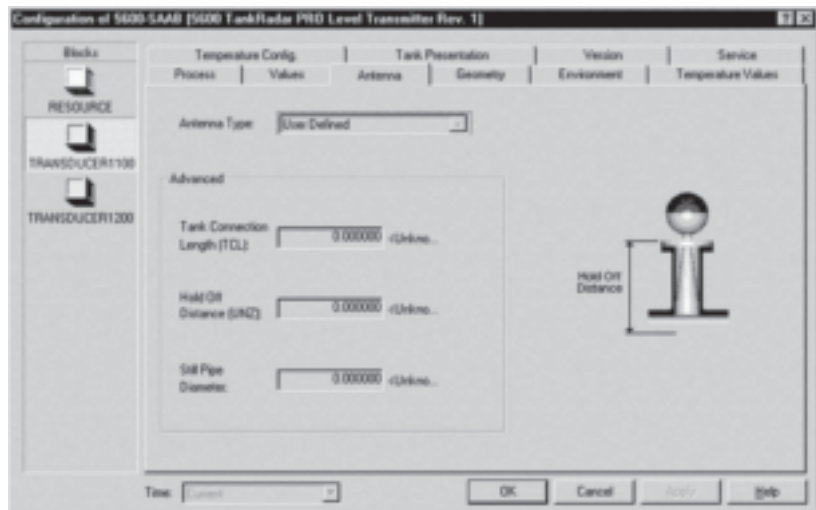

5600_K_01A.TIF

1. Choice of **Antenna Type** (ANTENNA_TYPE).
2. Based on antenna type choice, the different antenna related configuration parameters will be available for configuration. See Table 6-1 for Tank Connection Length (ANTENNA_TCL), and Antenna Pipe Diameter (ANTENNA_PIPE_DIAMETER).

Table 6-1. Parameters that are configurable for each antenna type

ANTENNA_TYPE	ANTENNA_TCL	ANTENNA_PIPE_DIAM	GEOM_HOLD_OFF
User Defined	configurable	configurable	configurable
Cone	factory configured	factory configured	configurable
Pipe	factory configured	configurable	configurable
Rod	factory configured	factory configured	configurable
Process Seal	factory configured	factory configured	configurable

Rosemount 5600 Series

Geometry

Figure 6-8. Configuring the Rosemount 5600 Transducer Block (Geometry Tab)

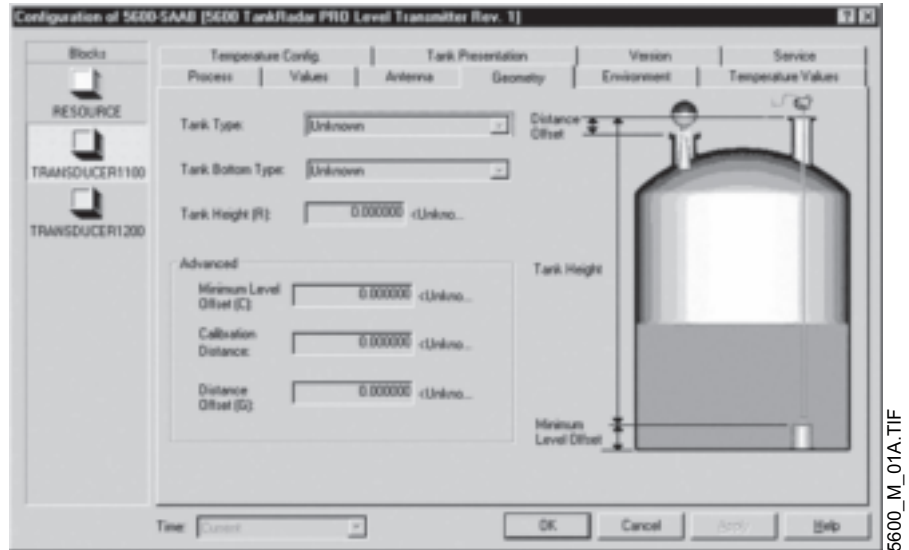

1. Setup the **tank type** (GEOM_TANK_TYPE) and tank geometry parameters (GEOM_TANK_BOTTOM_TYPE). The following combinations of Tank Type and Tank Bottom Type are valid:

Table 6-2. Tank Bottom

Tank Type	Tank Bottom Type
Vertical Cylinder	Flat, Dome, Cone, Flat inclined
Horizontal Cylinder	Not Applicable
Spherical	Not Applicable
Cubical	Flat, Dome, Cone, Flat inclined

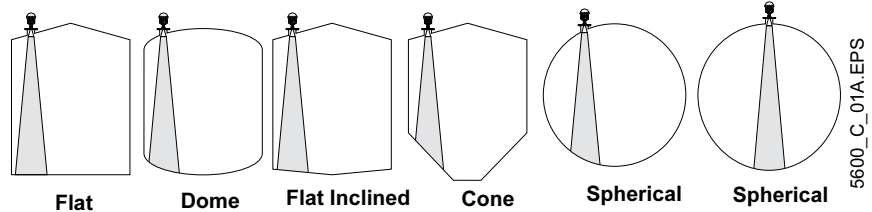

2. Set **Tank Height** (GEOM_TANK_HIGH). The tank height is defined by the difference between the Upper Reference Point (transmitter point) and the Lower Reference Point (zero level). See “Tank Geometry” on page 4-5 for additional information.

Figure 6-9. Tank Height

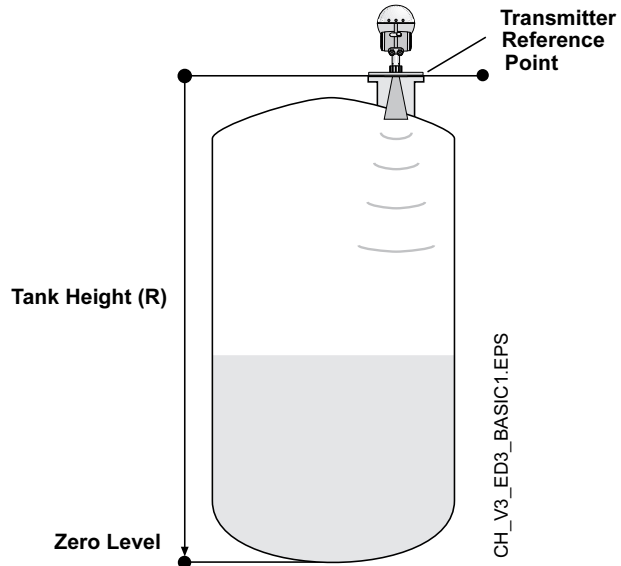

FOUNDATION Fieldbus

3. Double click the transmitter you wish to configure/calibrate.

The function blocks within the transmitter appear in the right half of the DeltaV Explorer window (see Figure 6-4).

Environment

Figure 6-10. Configuring the Rosemount 5600 Transducer Block (Environment Tab)

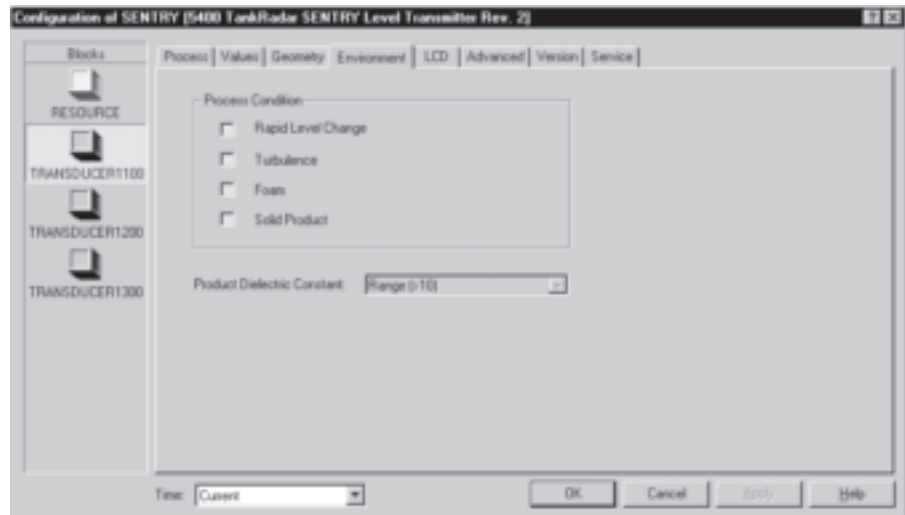

1. Select the Environment tab.
2. Set the process conditions:
 - a. Process dielectric constants (ENV_DIELECTR_CONST)
 - b. Process conditions (ENV_ENVIRONMENT)

Rapid level changes	Optimize the transmitter for measurement conditions where the level changes quickly due to filling and emptying of the tank. A standard configured transmitter is able to track level changes of up to 4 inch/s (100 mm/s). When the Rapid Level Changes check box is marked, the transmitter can track level changes of up to 8 inch/s (200 mm/s).
Turbulent Surface	This parameter should be used if the tank shows a turbulent surface. The reason for the turbulence might be splash loading, agitators, mixers, or boiling product. Normally the waves in a tank are quite small and cause local rapid level changes. By setting this parameter the performance of the transmitter will be improved when there are small and quickly changing amplitudes and levels.
Foam	Setting this parameter optimizes the transmitter for conditions with weak and varying surface echo amplitudes, which are typical for foam.
Solid Products	Setting this parameter optimizes the transmitter for solid products, for example concrete or grains, which are not transparent for radar signals. For instance, this parameter can be used when the application is a silo with product buildup.

CONFIGURE THE AI BLOCK

 A minimum of four parameters are required to configure the AI Block. The parameters are described with “Application Examples” on page 6-13.

CHANNEL

AI Block	TB Channel Value	Process Variable
Level	1	CHANNEL_RADAR_LEVEL
Ullage	2	CHANNEL_RADAR_ULLAGE
Level Rate	3	CHANNEL_RADAR_LEVELRATE
Signal Strength	4	CHANNEL_RADAR_SIGNAL_STRENGTH
Volume	5	CHANNEL_RADAR_VOLUME
Average Temperature	6	CHANNEL_RADAR_AVG_TEMP

L_TYPE

The L_TYPE parameter defines the relationship of the transmitter measurement (Level, Distance, Level Rate, Signal Strength, Volume, and Average Temperature) to the desired output of the AI Block. The relationship can be direct or indirect.

Direct

Select direct when the desired output will be the same as the transmitter measurement (Level, Distance, Level Rate, and Signal Strength).

Indirect

Select indirect when the desired output is a calculated measurement based on the transmitter measurement. The relationship between the transmitter measurement and the calculated measurement will be linear.

Indirect Square Root

Select indirect square root when the desired output is an inferred measurement based on the transmitter measurement and the relationship between the sensor measurement and the inferred measurement is square root (e.g. level).

XD_SCALE and OUT_SCALE

The XD_SCALE and OUT_SCALE each include three parameters: 0%, 100%, and engineering units. Set these based on the L_TYPE:

L_TYPE is Direct

When the desired output is the measured variable, set the XD_SCALE to match the OUT_SCALE value.

L_TYPE is Indirect

When an inferred measurement is made based on the sensor measurement, set the XD_SCALE to represent the operating range that the sensor will see in the process. Determine the inferred measurement values that correspond to the XD_SCALE 0 and 100% points and set these for the OUT_SCALE.

L_TYPE is Indirect Square Root

When an inferred measurement is made based on the transmitter measurement and the relationship between the inferred measurement and sensor measurement is square root, set the XD_SCALE to represent the operating range that the sensor will see in the process. Determine the inferred measurement values that correspond to the XD_SCALE 0 and 100% points and set these for the OUT_SCALE.

NOTE

To avoid configuration errors, only select Engineering Units for XD_SCALE that are supported by the device. The supported units are:

Rosemount 5600 Series

Table 6-3. Length

Display	Description
m	meter
ft	feet
in	inch
mm	millimeter

Table 6-4. Level Rate

Display	Description
ft/s	feet per second
m/s	meter per second
m/h	meter per hour

Table 6-5. Temperature

Display	Description
K	Kelvin
°C	Degree Celsius
°F	Degree Fahrenheit

Table 6-6. Signal Strength

Display	Description
mV	Millivolt

Table 6-7. Volume

Display	Description
m ³	Cubic meter
Gallon	US gallon
bbl	barrel
ft ³	Cubic feet

**APPLICATION
 EXAMPLES**

**Application Example:
 Radar Level Transmitter,
 Level Value**

Situation #1

A level transmitter is measuring the level in a 33ft (10m) high tank.

Figure 6-11. Situation #1
 Diagram

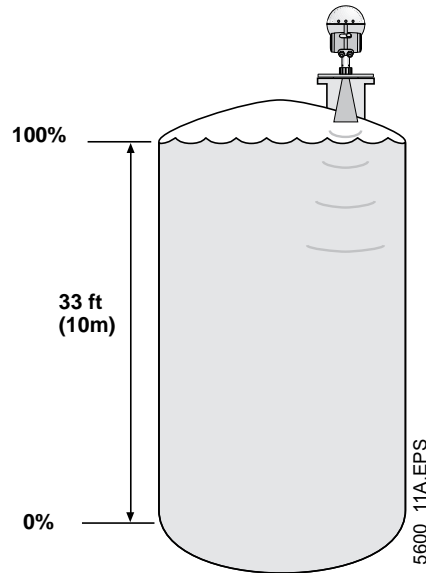

FOUNDATION Fieldbus

Solution #1

Table 6-8 lists the appropriate configuration settings, and Figure 6-12 illustrates the correct function block configuration.

Table 6-8. Analog Input
 Function Block Configuration for
 a Typical Level Transmitter

Parameter	Configured Values
L_TYPE	Direct
XD_SCALE	Not Used
OUT_SCALE	Not Used
CHANNEL	1 Level

Figure 6-12. Analog Input
 Function Block Diagram
 for a Typical Level Transmitter

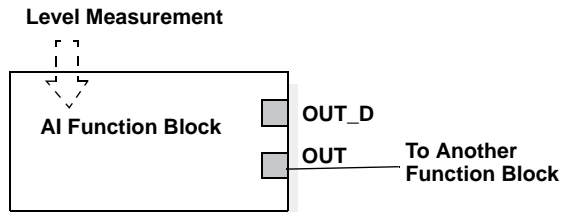

FIELDBUS-FBUS_04A

Rosemount 5600 Series

Application Example: Radar Level Transmitter, Level value in percent (%)

Situation #2

The level of a tank is to be measured using the Radar Level transmitter mounted on a nozzle on the top of the tank. The maximum level in the tank is 46ft (14m). The level value shall be displayed in percentage of the full span (see Figure 6-13).

Figure 6-13. Situation #2
Diagram

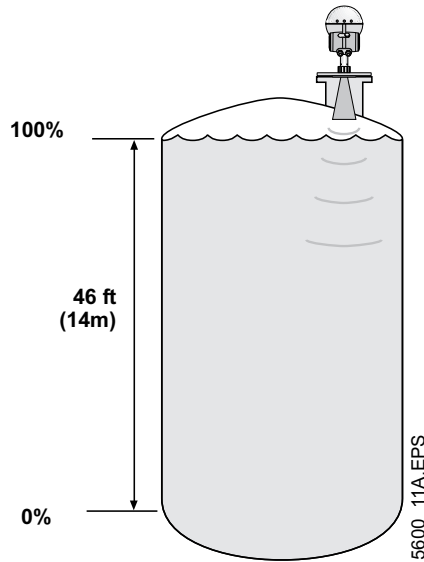

Solution #2

Table 6-9 lists the appropriate configuration settings, and Figure 6-14 illustrates the correct function block configuration.

Table 6-9. Analog Input
Function Block Configuration for
a Level Transmitter where level
output is sealed between
0-100%

Parameter	Configured Values
L_TYPE	Indirect
XD_SCALE	0 to 14 m
OUT_SCALE	0 to 100%
CHANNEL	1 Level

Figure 6-14. Function Block
Diagram for a Level Transmitter
where level output is sealed
between 0-100%

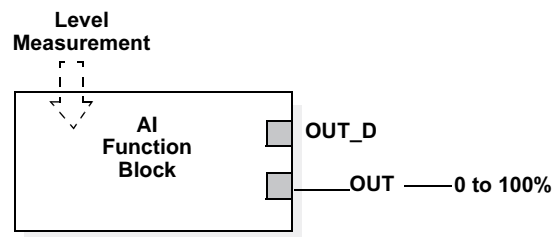

**Application Example:
 Radar Level Transmitter
 used to Display Volume**

Situation #3

The volume of the tank is to be calculated using the Radar Level Transmitter.

Figure 6-15. Situation #3
 Diagram

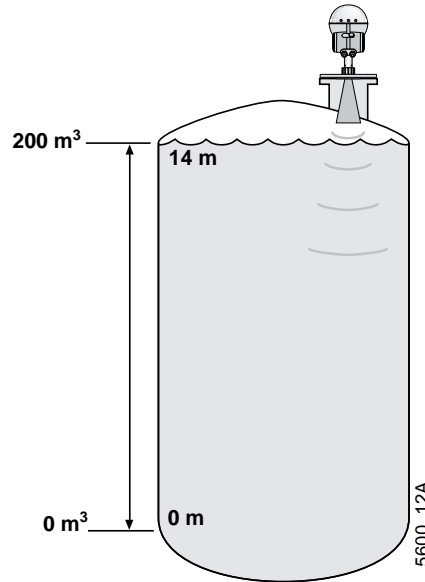

FOUNDATION Fieldbus

Solution 3.1

In this solution the volume channel in the analog input block is used to obtain the volume.

Table 6-10. Analog Input
 Function Block Configuration for
 a Radar Level Transmitter used
 in Level Measurement
 (Situation #3)

Parameter	Configured Values
L_TYPE	Direct
XD_SCALE	Not Used
OUT_SCALE	Not Used
Channel	5 Volume

Figure 6-16. Analog Input
 Function Block Diagram
 for a Typical Level Transmitter

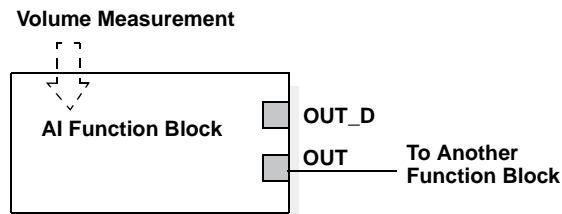

FIELDBUS-FBUS_04A

Rosemount 5600 Series

Solution #3.2

In this solution the level channel in the analog input block is used to obtain the volume.

Table 6-11. Analog Input Function Block Configuration for a Radar Level Transmitter used in Level Measurement (Situation #3)

Parameter	Configured Values
L_TYPE	Indirect
XD_SCALE	0 to 14m
OUT_SCALE	0 to 200m ³
Channel	1 Level

Figure 6-17. Function Block Diagram for a Level Transmitter where level output is sealed between 0-100%

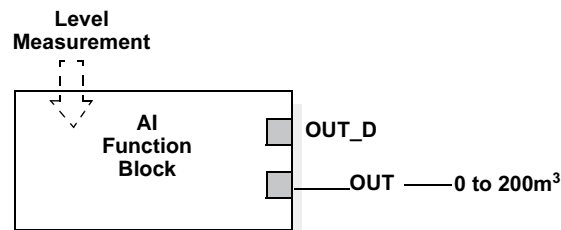

CONFIGURATION USING THE SENSOR BUS PORT

When using a 5601 with FOUNDATION Fieldbus the configuration of the transmitter is done via DeltaV or other Fieldbus Host. With the help of Device descriptors these hosts are able to present, read, and write necessary information and data within the transmitter and assist the user to a successful configuration of the transmitter.

In some cases, there could be a need for a more advanced service access to the transmitter. This is done by using the Radar Master and accessing the data from the Sensor Bus Port, which is always readily available. Below are instructions of how to connect this port and how to use it.

Electrical Connection

The electrical interface is RS-485 (2-wire) and the language spoken (protocol) is Modbus.

To be able to connect to the Sensor Bus on the Rosemount 5601, you must have a RS-232/485 converter. Below you find two models of such RS-232/485 modems which have been successfully used to communicate with the 5601 on the Sensor Bus. Basically any type of RS-232/485 converter can be used but different Models use different switches/settings etc., and therefore they are not listed here. The recommended type for field use is the K2.

The converter is to be connected on the Sensor Bus Port which is normally used by the Rosemount 2210 Display Unit. Disconnect the communication wires (X2: 6 & 7) to the Display Unit.

Connecting the K2 ADE Modem

Once the Rosemount 2210 Display Unit has been disconnected, connect the K2 ADE modem to terminals 6 and 7 on the 5601 transmitter according to Figure 6-18.

NOTE

The K2 can not be used in Intrinsically Safe area.
 The part number for the K2 ADE modem is 05600-5004-0001.

The K2-ADE is a small and handy converter which is connected directly to the COM-port. It will take the power from the COM-port of the computer.

NOTE

Some computers can not supply enough power and in such cases you can try the 'intelligent' mode. This means you set a fixed Baud rate on the converter (using the DIP-switches) and it will control the RS-485 dataflow direction automatically (without the need for any control signals (i.e. RTS) from Radar Master Software).

For best communication performance, a 120 ohm resistor must be connected on the K2 1 & 2 terminal.

Figure 6-18. Connection of K2 Modem

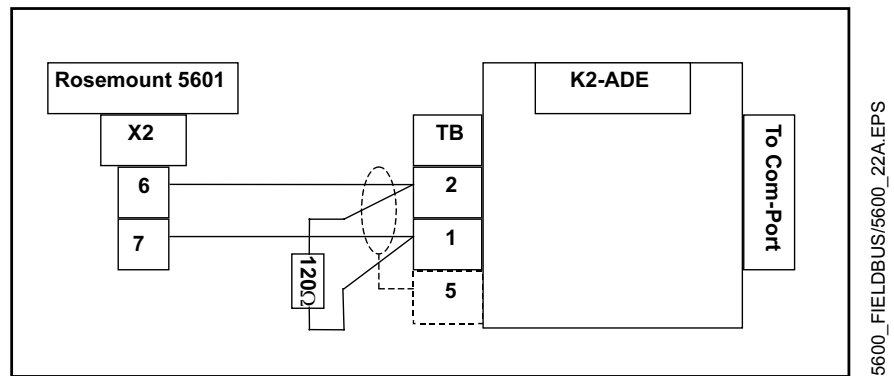

Set the K2 converter per Figure 6-19 to be controlled by the RTS signal from the Radar Master software.

Figure 6-19. DIP-switch setting on the K2 converter.

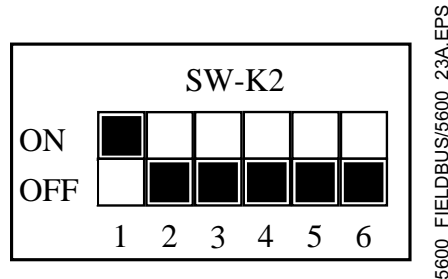

FOUNDATION Fieldbus

Rosemount 5600 Series

Switching to Sensor Bus Mode

By using the Sensor Bus method in DeltaV or applicable Fieldbus host the user is automatically setting the transmitter in “Out Of Service” mode. Then it sets the transmitter in the Sensor Bus Mode.

Basic connection and configuration description

1. Make the electrical connection, as described in Figure 6-18 and Figure 6-19.
2. Open Radar Master and change protocol to Modbus and modem type to RS-485.
3. Search for a new online device by selecting New Device in the Device menu. The default unit has Modbus address 246.
4. Enter the configuration windows as required for the configuration

NOTE

Do not enter any 2210 Display Unit configuration windows.

5. Disconnect from the device.
6. Use the Online Help in the Radar Master for further instructions of how to configure the transmitter.

Detailed Connection and Configuration description

1. Make the electrical connection, as described in Figure 6-18 and Figure 6-19.
2. When you start Radar Master you will get a ‘RRM Startup’ window with some options, press Cancel. Go to: Open View\Communication Preferences\ and set the communication as below:
 - Disable the HART communication before Enabling the Modbus Communication (Only necessary if the same Communication Port is used).
 - Modem: RS-485
 - Baud Rate: 4800
 - Stop bit: 1
 - Handshake: RTS/CTS/DTR/DSR
 - Retries: 10
 - The rest are left as default

Figure 6-20. Setting Modbus communication using the Radar Master



5600_COMMUNICATION.TIF

3. Search for the transmitter by entering the Device\New Device

Figure 6-21. Search for transmitter using the Radar Master

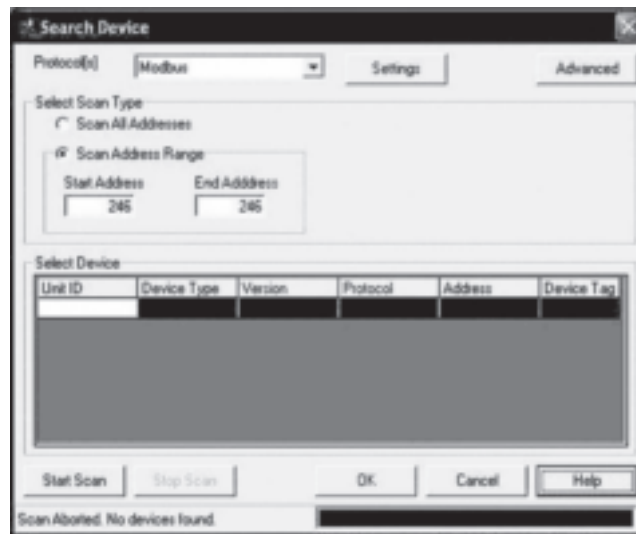

5600_COMMUNICATION.TIF

4. Once the transmitter is found, select it and press OK.
5. Enter any Configuration or Service window within Radar Master and perform the configuration and setup as normally done.

NOTE

Do not enter any Rosemount 2210 Display Unit configuration windows since the display unit is disconnected. This will result in a software halt in the transmitter. Should this happen, please cycle the transmitter power and restart the unit. Go back to Step 3 and continue from there.

6. When finished press “Disconnect” by right-clicking on the transmitter in the Device explorer in Rosemount Radar Master.

Rosemount 5600 Series

Section 7 2210 Display Unit Configuration

Safety Messages	page 7-1
Rosemount 2210 Display Unit	page 7-2

SAFETY MESSAGES

Procedures and instructions in this section may require special precautions to ensure the safety of the personnel performing the operations. Information that raises potential safety issues is indicated by a warning symbol (⚠). Please refer to the following safety messages before performing an operation preceded by this symbol.

 WARNING
<p>Explosions could result in death or serious injury:</p> <p>Verify that the operating environment of the transmitter is consistent with the appropriate hazardous locations certifications.</p> <p>Before connecting a HART-based communicator in an explosive atmosphere, make sure the instruments in the loop are installed in accordance with intrinsically safe or non-incendive field wiring practices.</p> <p>Do not remove the transmitter cover in explosive atmospheres when the circuit is alive.</p>

2210 Display Unit

Rosemount 5600 Series

ROSEMOUNT 2210 DISPLAY UNIT

Figure 7-1. Rosemount 2210 Display Unit Menu Tree

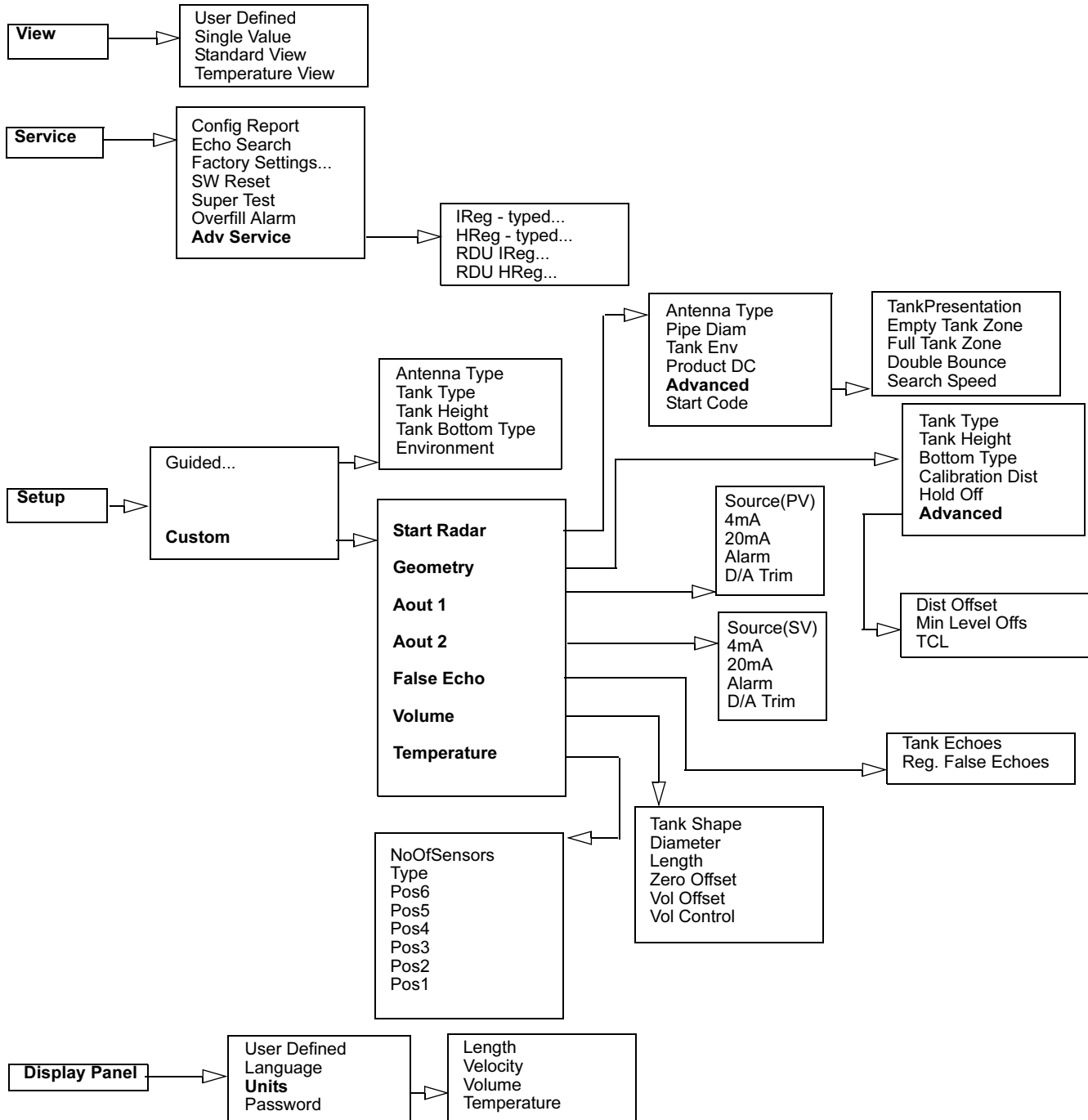

Operation

The Rosemount 2210 Display unit can be used for configuration as well as for viewing tank data. The four softkeys allow you to navigate through the different menus, and to select various functions for service and configuration. (See Section 2: Mechanical Installation for information on how to connect the 2210 Display Unit.)

If you leave the Display Unit in Service or Setup mode without pushing any button for 10 minutes (set in User Defined), it is automatically switched to View mode, presenting the same measurement variable that was displayed last time View mode was open.

The main menu contains the following options:

Figure 7-2. Main Menu

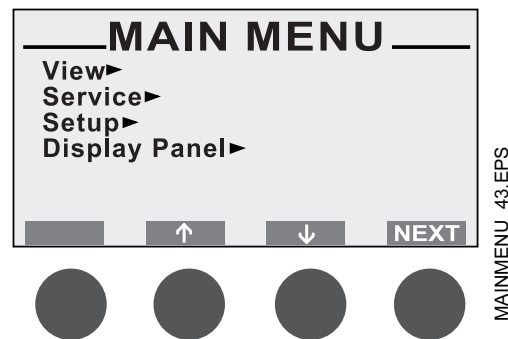

- The **View** option allows you to view level data and signal strength.
- The **Service** option allows you to view configuration status, edit holding registers, reset holding registers to factory values, do a software reset or to start a search for the surface echo.
- The **Setup** option allows you to configure a transmitter.
- The **Display Panel** option allows you to set units for measured values, to set language and to change the user password.

Adjusting the LCD contrast

The LCD contrast can be increased by simultaneously pressing the two buttons on the right-hand side. Press the two left-hand buttons to decrease the contrast. It takes approximately 10 seconds to adjust from minimum to maximum display panel contrast.

Entering a Password

Some windows are protected by a password. The password is entered by pressing the three blank softkeys in a certain order (maximum 12 characters). Each figure refers to a particular softkey, as illustrated.

As default the password is blank, i.e. you can open a password protected window merely by pressing the **OK** button. In order to use the password protection you have to set the password as described in Display Setup and below.

Figure 7-3. Password screen

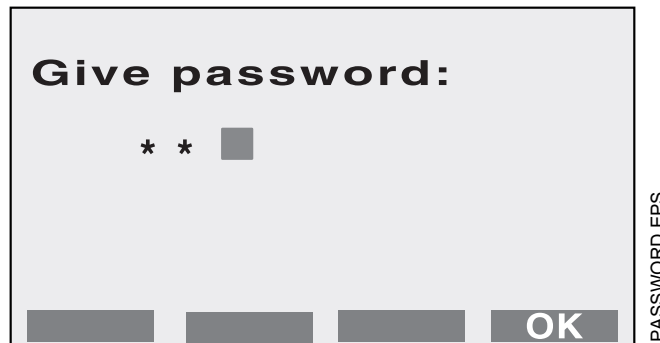

Example: If the password is "231", you start by pressing the second key, then the third key and finally the first softkey. You can change the password at any time by opening the **Display Panel** menu.

Softkeys

The softkeys have different meanings depending on which window that is open. Use the arrow buttons to move the cursor up and down (or sideways in some windows). These buttons are also used for changing figures when you are asked to enter a value.

Figure 7-4. View Menu

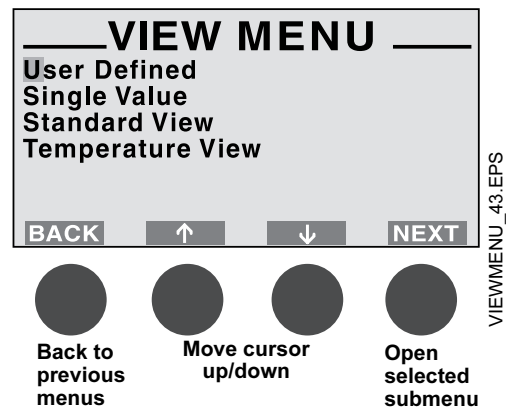

Presentation of measured data

When viewing measurement data, you can use the softkeys to move between different views as illustrated below. There are also status indicators showing you that measurements are performed, and whether these measurements are valid or not.

Figure 7-5. View Display

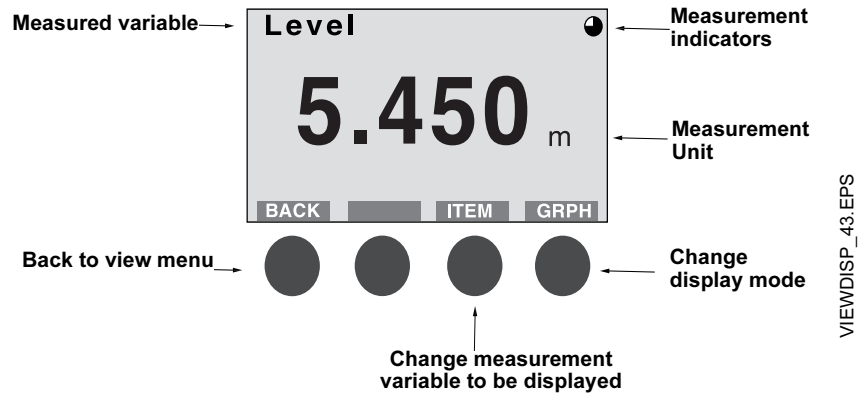

VIEWDISP_43.EPS

Selecting between different alternatives

When you configure the 5600, the softkeys will take on definitions which allow you to select specific items and to save the current settings.

When the cursor has reached the last item, it jumps back to the first item by pressing the down arrow button.

Figure 7-6. Set antenna type

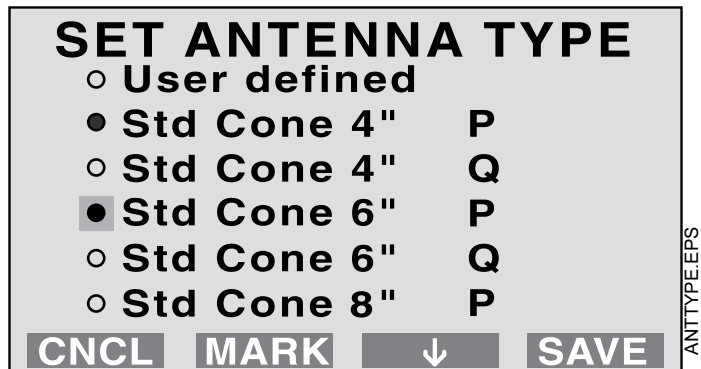

ANTTYPE.EPS

NOTE

When the word **MARK** appears, it must be used to save the selected value.

2210 Display Unit

Entering numerical values

Use the up arrow button to enter the desired value. Each click increases the digital value one step from zero to nine and back to zero.

The **Next** button is to move the cursor to the next digit. When the cursor reaches the last digit, select **NEXT** to move back to the first digit again.

Figure 7-7. Give Startcode

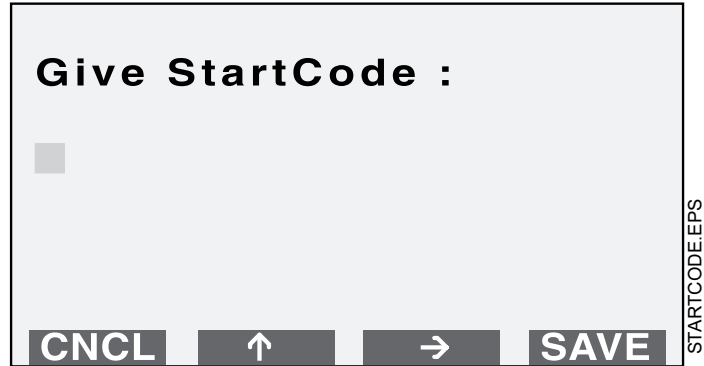

Viewing Level Data

The View Menu

the **View Menu** includes options for viewing tank and transmitter related data:

Figure 7-8. View Menu

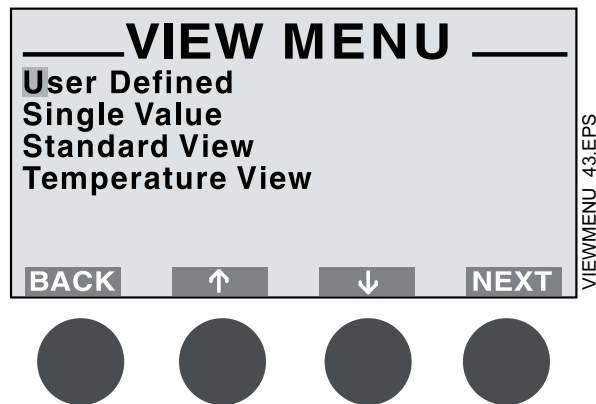

- Press **Back** to return the main menu.
- Use the arrows to move the cursor up or down.
- Press **Next** to open the selected submenu.

User Defined

Select the **User Defined** submenu to view measured data according to defined settings. The first time this submenu is accessed you will be asked to define your preferred settings.

Single Value

Select **Single Value** to view measured data.

Press **Item** to choose between the following:

- Level
- Ullage (distance)
- Level Rate
- Signal Strength
- Volume

To switch between the following display modes, select **GRPH**:

- Numerical - measured data is presented as a value
- Bar graph - the measured value is presented in a bar graph showing the current value.

Standard View

Select **Standard View** from the **View** menu to view a list of measured variables.

Figure 7-9. Standard View menu

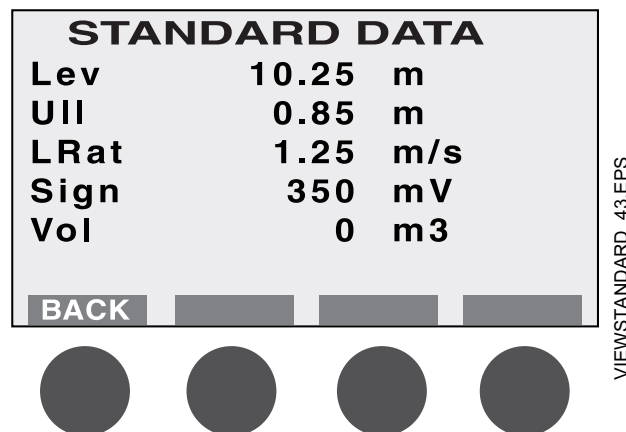

2210 Display Unit

Temperature View

Select **Temperature View** from the **View** menu to view measured temperatures from the connected temperature sensors.

Display Setup

The Display Setup is used to set presentation units, language, and password in the 2210 Display only. If you do not want to change the default settings, skip this step and go to Custom Setup. To configure the display panel, access the Display Setup Window by selecting the Display Panel option from the Main Menu and pressing **Next**.

Rosemount 5600 Series

User Defined View

1. Select **User Defined** and press **Next**.
2. The number of selections above decides if the next choice is to select type or mode. If one item was selected, select type and press **Next**. If two or more items were selected, select mode and press **Next**. For the toggling mode also select how long each item will be shown and press **Next**.
3. Select units for the selected items and press **Next**.
4. Set time out in minutes for the display to return to default view and press **Save**.

Language

1. Select **Language** and press **Next**.
2. Move the cursor to the preferred language and press **Mark**.
3. Save your choice by pressing **Save**. The display will return to the view mode.

Units

1. Select the **Units** menu and press **Next**.
2. Select **Length, Velocity, Volume, or Temperature** and press **Next**. the measurement unit to be used for presentation of data and click **Save**.

Password

To change your display panel password select the **Password** option and press the button. This password must be entered in order to be able to change the transmitter configuration. Follow the procedure Entering a Password.

1. Select **Setup** from the Main Menu and choose one of the options to configure the transmitter.

NOTE

The Setup dialog is automatically opened when a transmitter is started for the first time.

Guided Setup

The Guided Setup option contains the basic steps for configuration of the 5600 Radar Level Transmitter.

Custom Setup

Use the Custom Setup option if you for example want to include options for volume calculations and disturbance echo handling.

Installing a Rosemount 5600 Radar Level Transmitter

Guided Setup

The **Guided Setup** includes the basic steps to start the transmitter. This option gives a guided step by step through a sequence of configuration windows. The windows are automatically opened in a predefined order. To configure a new radar transmitter using the Guided Setup option do the following:

1. Choose Setup from the Main Menu.
2. Enter your password and press the button. The password is defined by clicking the first three softkeys in a given order. An asterisk is shown for each key that is pressed.
3. Select "Guided..." from the Setup Menu and press **Next**.
4. Set the Antenna Type. Press **Save** to move the cursor to the desired antenna, and click **Mark** to select it (see Figure 7-6 on page 7-5).
Std = standard;
P = PTFE tank sealing;
Q = quartz sealing;
HP = factory use only;
C = factory use only.

Finish by pressing **Save**. Note that you have to scroll the list using the arrows to find all available antenna types.

NOTE

Dimensions must be entered in meters. Values may be displayed in metric or english units.

5. Set the **Tank Type**. Press the arrow button to move the cursor to the desired Tank Type, and click **Mark** to select it.
6. Calibrate the **Tank Height (R)**. The **Tank Height (R)** is defined as the distance between the upper reference point (specified by the Distance Offset G) and the lower reference point (zero level). Finish by pressing **Save**.
7. If the Tank Type is selected so that a Tank Bottom Type is necessary to define, press the arrow button to move the cursor to the desired Tank Bottom Type. Click **Mark** to select it.
8. Choose the **Tank Environment** option. Select appropriate surface conditions. Mark the options that describes the conditions in your tank by selecting **Mark**.

NOTE

See Section 4: Configuration for further information on how to set the tank geometry and environment parameters.

Custom Setup

To configure a radar transmitter using the **Custom Setup** option, do the following:

1. Choose **Setup** from the Main Menu.
2. Enter your password and press **OK**.
3. Select **Custom** from the Setup Menu and press **Next**.
4. Select the **Start Radar** option from the Custom Setup menu.
 - a. Choose the **Antenna Type** option from the **Start Radar** menu. Examples of antennas available are Rod, Cone, Process Seal, and Parabolic.
 - b. Select the type of antenna that is mounted on the transmitter and click **Save** to open the Start Radar menu.
 - c. Choose the **Tank Environment** option. Select appropriate surface conditions. Mark the options that describes the conditions in your tank by selecting **Mark**.

NOTE

For best performance choose only if applicable and not more than two options, see page 4-6 for more information about the different settings.

- d. Press **Save** to store the current setting.
- e. Choose the **Product DC** option. The product dielectric constant defines how well the product will reflect microwaves. See the product data sheet (00813-0100-4024) for the correct value. Mark the appropriate range and press the button. When Unknown is used, the transmitter can not be optimized for the product.
- f. Choose the **Start Code** option. Confirm your **Start Code** by selecting **Save**. The transmitter is delivered with a start code that enables the ordered software options. If you wish to change the set of available options, contact your local representative for a new start code. Check the list of enabled options. Contact your local representative if you would like to add one or more software options. If the list is correct confirm by pressing **OK**.
- g. Press **Back** to return to the **Custom Setup** menu. The **Advanced** option allows you to make advanced setup of Tank Environment database registers (for trained personnel only).

5. Select the **Geometry** option from the Custom Setup menu.
 - a. Select **Tank Type** and press **Next**. Select Tank Shape option and press **Save**.
 - b. Select **Tank Height** and press **Next**. The **Tank Height (R)** is defined as the distance between the upper reference point and the lower reference point (zero level). Set the **Tank Height** and press **Save**.
 - c. Select **Bottom Type** and press **Next**. Select Tank Bottom option and press **Save**.
 - d. The **Calibration Distance** is by default set to zero. It is used to adjust the transmitter so that measured levels match hand dipped product levels. Normally a minor adjustment is necessary. There may for example be a deviation between the actual tank height and the value stored in the transmitter database. Set the **Calibration Distance** and press **Save**.

NOTE

See Section 4: Configuration for further information on how to set the tank geometry parameters.

- e. Select the **Advanced** menu and press **Next**. Set the **Distance Offset (G)**. The Distance Offset (G) is defined as the distance between the upper reference point and the flange (the flange is referred to as the Transmitter's Reference Point). You can use the Distance Offset to specify your own reference point at the top of the tank. Set the Distance Offset to zero if you want the flange as upper reference point. The Distance Offset is defined as positive if you use an upper reference point above the Transmitter's Reference Point. The Distance Offset is used when the measured level by the transmitter should correspond with the level value obtained by hand-dipping.
- f. Set the **Minimum Level Offset (C)**. The Minimum Level Offset (C) defines a lower null zone which extends the measurement range beyond the Zero Level Reference Point down to the tank bottom. The Minimum Level Offset is defined as the distance between the zero level (Tank Level Reference Point) and the minimum accepted level, i.e. the tank bottom. Set the Minimum Level Offset to zero if you use the tank bottom as zero level reference point. If the zero level is not defined as the tank bottom and instead is an elevated point as the datum plate, you need to define the Minimum Level Offset. Note that the Minimum Level Offset can not be negative.
- g. Set the **Tank Connection Length (TCL)**. The **Tank Connection Length (TCL)** parameter is entered for antenna type User Defined only. For standard antennas the TCL value is set automatically.

6. Select the **Analog Out 1** option from the Custom Setup menu (Optional). If the transmitter is equipped with an analog output, the range of the output is automatically calibrated to match the tank calibration (Distance Offset and Tank Height). If you want to change this setting, do the following:
 - a. Enter **Source**. Available options are: level, ullage, level rate, signal strength, and volume (T1-T6 and Average Liquid Temp. optional).
 - b. Enter the analog output values that correspond to **4 mA** and **20 mA**, respectively.
 - c. Select **Alarm mode**: Low Current, High Current, Freeze, BinLow, BinHigh
 - d. **D/A Trim**. Use this option to calibrate the Digital/Analog Converter to correspond to the nominal values 4 mA and 20 mA.

NOTE

The analog output is set to fixed current mode during the calibration procedure.

To calibrate the DAC do the following:

- a. Choose the **D/A Trim** option.
 - b. Click the **OK** button if you want to continue, (or click **CNCL** to quit without calibrating the D/A converter).
 - c. Enter the measured value that corresponds to the 4 mA setting.
 - d. Click the **DONE** button.
 - e. Enter the measured value that corresponds to the 20 mA setting.
 - f. Click the **DONE** button. Now the D/A calibration is finished, and the analog output is no longer in fixed current mode.
7. Select the **Analog Out 2** option from the Custom Setup menu (optional). If the transmitter is equipped with an extra analog output, follow the same configuration procedure as for Analog Out 1. Configuration of the extra analog output is identical to configuration of analog output 1. See step 6 above.

8. Select the **False Echo** option from the Custom Setup menu (optional). In normal operation the transmitter compares detected echoes with a list of **registered** disturbance echoes, in order to decide which one is the actual product surface. To view a list of echoes that the transmitter has detected select the **Tank Echoes** option.
Select echoes from this list and add to the list of registered echoes. Only register disturbing echoes which can be identified as caused by an object in the tank. To register a disturbance echo, do the following:
 - a. Move the cursor to the echo you want to add to the list.
 - b. Click **Edit**.
 - c. Move the cursor to **Add to list**, and click **Mark**.
 - d. Click **Save** to register the marked echo.
 - e. Repeat steps **a** to **d** if you wish to register more disturbance echoes. The **Set as surface** option allows you to define an echo as the product surface. Mark the **Add new false** option if you want to manually add echoes. This may be a useful option if, for example, there are known disturbances below the product surface which can not be detected by the transmitter at the time of installation.
 - f. Click **CNCL** to return to the False Echo menu. To view the current list of registered disturbing echoes select the **Reg. False Echoes**.

To remove a registered disturbance echo, do the following (see "Disturbance Echo Handling" on page 4-11):

- a. Move the cursor to the echo you want to remove.
- b. Click **Edit**.
- c. Select the **Remove echo** option and click **MARK**.
- d. Click **Save** to remove the selected echo.

Mark the **Add new false** option if you want to manually add a false echo to the list of registered disturbance echoes. Mark the **Clear list** option if you want to remove the whole list of registered disturbance echoes. This option may be useful if you want to create a completely new list.

9. Select the **Volume** option from the Custom Setup menu. The **Volume** option allows you to setup the 5600 transmitter for volume calculations. You can choose between using either a predefined tank shape like a sphere or a horizontal or vertical cylinder, or entering level and volume values into a strapping table.
 - a. Select **Shape** and press **Edit**. Choose the Tank Geometry to be used for volume calculation and press **Save**.
 - b. Select **Diam** and press **Edit**. Set the tank diameter and press **Save**.
 - c. Select **Zero Level Offset** and press **Edit**. Set the distance from zero level to tank bottom and press **Save**.
 - d. Select **Volume Offset** and press **Edit**. Set the volume offset and press **Save**.
 - e. Select **Volume Control** and press **Edit**. Mark the NegVolDisabled option and press **Save**.

Section 8 Maintenance and Troubleshooting

Overview	page 8-1
Safety Messages	page 8-1
HART Maintenance and Troubleshooting	page 8-2
Fieldbus Maintenance and Troubleshooting	page 8-4
Resource Block	page 8-8
Transducer Block	page 8-9
Analog Input (AI) Function Block	page 8-9

OVERVIEW

This sections contains operating, maintenance, and troubleshooting information for the Rosemount 5600 HART and FOUNDATION Fieldbus.

SAFETY MESSAGES

Procedures and instructions in this section may require special precautions to ensure the safety of the personnel performing the operations. Information that raises potential safety issues is indicated by a warning symbol (⚠). Refer to the following safety messages before performing an operation preceded by this symbol.

Follow the procedures described here to verify that transmitter hardware and process connections are in good working order. Always deal with the most likely checkpoints first.

Warnings ⚠

⚠ WARNING

Explosions can result in death or serious injury.

- Do not remove the transmitter covers in explosive environments when the circuit is live.
- Transmitter covers must be fully engaged to meet explosion proof requirements.
- Before connecting a communicator in an explosive atmosphere, make sure that the instruments in the loop are installed according to intrinsically safe or nonincendive field wiring practices.

⚠ CAUTION

Static electricity can damage sensitive components.

- Observe safe handling precautions for static-sensitive components.

Rosemount 5600 Series

HART

HART MAINTENANCE AND TROUBLESHOOTING

If you suspect malfunction despite the absence of any diagnostic messages on the HART Communicator display and other configuration tools, follow the procedures described here to verify that transmitter hardware and process connections are in good working order. Always deal with the most likely checkpoints first.

Troubleshooting Table

Table 8-1 provides summarized troubleshooting suggestions for the most common operating problems.

Table 8-1. Rosemount 5600 HART troubleshooting table

SYMPTOM	ACTION
No level reading	Check the power supply. Check the cables for serial data communication.
Incorrect level reading	Check the transmitter calibration. Check that the transmitter has not locked on an interfering object. Check that the mechanical installation is correct.
Serial communication failure	Check the COM port setting in the Radar Master program (See page 8-3) Check the serial communication address. Check the cable connections and that the correct cables are used.
Display Panel window is blank Poor Display Panel contrast	Check the power supply Press the two right-hand buttons to increase the LCD contrast.

Service Using the Rosemount 2210 Display Unit

The Service Menu allows you to view the configuration status, edit holding registers, reset holding registers to factory values, do a software reset or to start a search for the surface echo. Information about antenna type, software versions, operation time, error status and unit code is available. You can also start a search for the surface echo and reset some of the holding registers to factory settings.

The service functions should only be used if you are familiar with the advanced functionality of the Rosemount 5600 Radar Level Transmitter.

Table 8-2. 5600 Advanced Functionality

Advanced Functionality	Purpose
Config Report	Shows information on antenna type, software versions, software and hardware configuration, operation time, error status and unit code.
Echo Search	Starts a search for the surface echo.
Factory Settings	Resets selected holding registers to factory settings.
Software Reset	Use this option to trigger the software start up procedure
Super Test	Enables all software options for one week. Use this option if you want to test options not available in your transmitter.
Overfill Alarm	Use this menu to activate or deactivate the overfill alarm.
Advanced Service	Use this option to view input registers and to view an edit holding registers. The Advance Service window is protected by a special password which is valid for this window only. Contact your local representative for this password if you need to use the Advance Service option.

Field Upgrades

Labeling

 Each radar transmitter is labeled individually, so it is imperative that the approval codes on each label match exactly during upgrade. The label on the radar transmitter reflects the replacement model code for reordering an assembled unit. The housing labeling will only reflect the approvals and communication protocol of the housing.

Figure 8-1. Example of the Rosemount 5600 transmitter head label and antenna label



HART

Connection via Sensor Bus Port

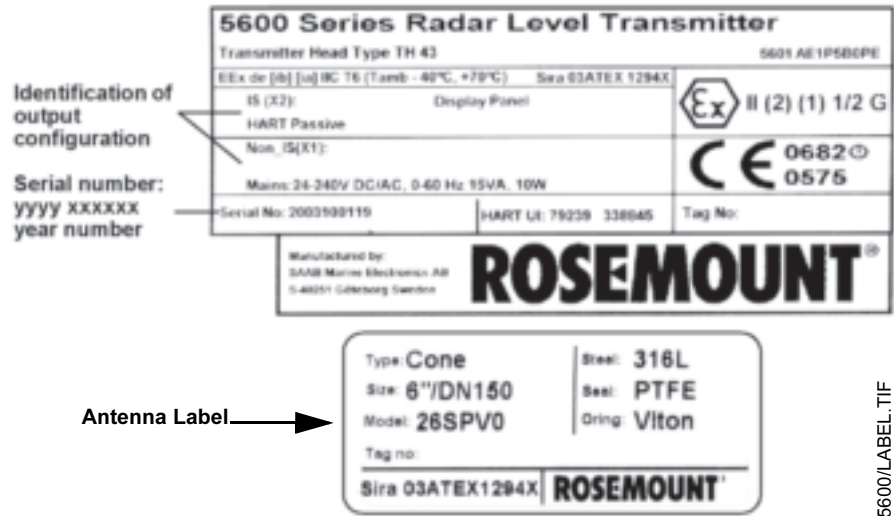
In addition to the standard communication ports, where HART or FOUNDATION fieldbus are the main protocols used, there is an additional Port available (Sensor Bus Port).

This port is mainly used for upgrading Firmware, or for the use of the Radar Master software in combination with a transmitter equipped with a FOUNDATION fieldbus output. To utilize this port you need a RS485 modem hooked up on terminals 6 and 7 on the Intrinsically Safe side of the transmitter. The software used is the standard Rosemount Radar Master. since terminals 6 and 7 are used by the Rosemount 2210 Display Unit you have to disconnect it first. For more information about this Sensor Bus port, please see the on-line help in the Radar Master software or contact your local Rosemount representative.

NOTE

For Windows 2000 and Windows XP you need to set the Serial Port buffer as instructed below:

1. Right click on My Computer and choose Properties
2. Choose the tab Hardware
3. Click on the button Device Manager
4. Navigate to Ports in the list of hardware
5. Right click on Serial Port COM 1 and choose Properties
6. Choose the tab Port Settings
7. Click Advanced
8. Drag the slider for Receive Buffer and Transmit Buffer to 1
9. Click OK
10. Reboot the Computer
11. Repeat for COM 2 or other communication port if available.

Rosemount 5600 Series

FIELDBUS MAINTENANCE AND TROUBLESHOOTING

Methods and Manual Operation

Each FOUNDATION fieldbus host or configuration tool has different ways of displaying and performing operations. Some hosts will use Device Descriptions (DD) and DD Methods to complete device configuration and will display data consistently across platforms. The DD can be found on www.rosemount.com. There is no requirement that a host or configuration tool support these features.

The information in this section will describe how to use methods in a general fashion. In addition, if your host or configuration tool does not support methods this section will cover manually configuring the parameters involved with each method operation. For more detailed information on the use of methods, see your host or configuration tool manual.

Configure Transmitter

Refer to Section 6: FOUNDATION Fieldbus Configuration for further information regarding the configuration of the Radar Transmitter.

Service Method

This method is for service purpose only. If your host does not support methods ENV_DEVICE_MODE it needs to be manually configured. The following options are available:

- FOUNDATION™ fieldbus:
Set the device in normal fieldbus communication mode.
- Sensor bus:
Set the device in sensor bus mode, which means that all communication goes through the external sensor bus instead of the fieldbus. This is used to connect PC configuration tools.
- Restart transmitter:
Restarts the device, not the fieldbus card.
- Set to factory default:
Sets all configured data to factory settings.

Calibration Distance Configuration

See page 4-6 for further information.

Master Reset Method (Resource Block)

To perform a master reset, run the Master Reset Method. If your system does not support methods, manually configure the Resource Block parameters listed below.

1. Set the RESTART = Run, Resource, Defaults, or Processor
 - Run = nominal state when not restarting (default)
 - Resource = not used by device
 - Defaults = sets parameters to FOUNDATION fieldbus default values
 - Processor = does a warm start of the fieldbus card and the transmitter

Write Protection (Resource Block)

Inputs to the security and write lock functions include the hardware security jumper, the hardware and software write lock bits of the FEATURE_SEL parameter, the WRITE_LOCK parameter, and the DEFINE_WRITE_LOCK parameter.

The WRITE_LOCK parameter limits access to modify parameters within the block except to clear the WRITE_LOCK parameter. During this time, the block will function normally updating inputs and outputs and executing algorithms. When the WRITE_LOCK condition is cleared, a WRITE_ALM alert is generated with a priority that corresponds to the WRITE_PRI parameter.

The FEATURE_SEL parameter enables the user to select a hardware or software write lock or no write lock capability. To enable the hardware security function, enable the HW_SEL bit in the FEATURE_SEL parameter. When this bit has been enabled the WRITE_LOCK parameter becomes read only and will reflect the state of the hardware jumper. In order to enable the software write lock, the SW_SEL bit must be set in the FEATURE_SEL parameter. Once this bit is set, the WRITE_LOCK parameter may be set to LOCKED or NOT LOCKED. Once the WRITE_LOCK parameter is set to LOCKED by either the software or the hardware lock, all user requested writes as determined by the DEFINE_WRITE_LOCK parameter shall be rejected.

The DEFINE_WRITE_LOCK parameter allows the user to configure whether the write lock functions (both software and hardware) will control writing to all blocks, or only to the resource and transducer blocks. Internally updated data such as process variables and error logs will not be restricted by the security jumper.

Table 8-3 displays all possible configurations of the WRITE_LOCK parameter.

Table 8-3. WRITE_LOCK parameter

FEATURE_SEL HW_SEL bit	FEATURE_SEL SW_SEL bit	SECURITY JUMPER	WRITE_LOCK	WRITE_LOCK Read/Write
0 (off)	0 (off)	NA	1 (unlocked)	Read only
0 (off)	1 (on)	NA	1 (unlocked)	Read/Write
0 (off)	1 (on)	NA	2 (locked)	Read/Write
1 (on)	0 (off) ⁽¹⁾	0 (unlocked)	1 (unlocked)	Read only
1 (on)	0 (off)	1 (locked)	2 (locked)	Read only

(1) The hardware and software write lock select bits are mutually exclusive and the hardware select has the highest priority. When the HW_SEL bit is set to 1 (on), the SW_SEL bit is automatically set to 0 (off) and is read only.

Figure 8-2. 5600 Foundation Fieldbus Electronic Board

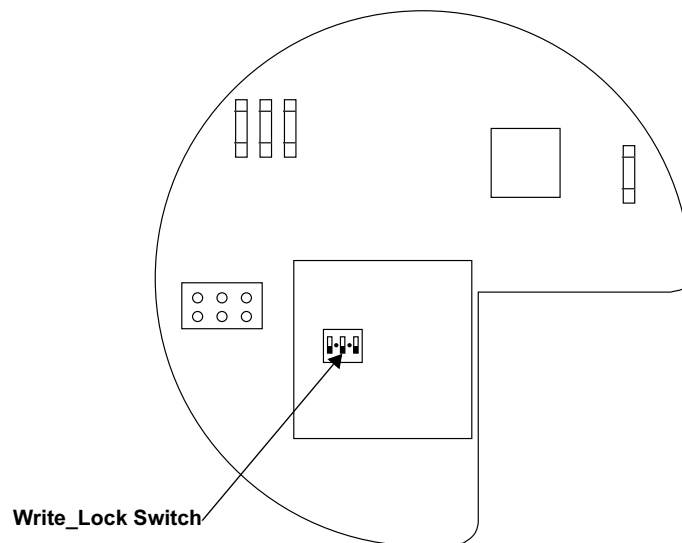

Rosemount 5600 Series

Block Instantiation

The Rosemount 5600 supports the use of Function Block Instantiation. When a device supports block instantiation, the user can define the number of blocks and block types to match specific application needs. The number of blocks that can be instantiated is only limited by the amount of memory within the device and the block types that are supported by the device. Instantiation does not apply to standard device blocks like the Resource, Level Transducer, and Register Transducer Block. Block instantiation is done by the host control system or configuration tool, but not all hosts are required to implement this functionality. Please refer to your specific host or configuration tool manual for more information.

Rosemount devices are pre-instantiated with function blocks at the factory, the default configuration for the Rosemount 5600 is listed below.

- 6 Analog Input Blocks (tag names AI 1300 through AI 1800)

Troubleshooting Table

Table 8-4 provides summarized maintenance and troubleshooting suggestions for the most common operating problems. This section contains Rosemount 5600 fieldbus troubleshooting information only.

Table 8-4. Rosemount 5600 troubleshooting table

Symptom	Corrective Actions
FOUNDATION fieldbus Card to Transmitter Communication Fault	Verify Device Mode setting, should be Foundation fieldbus (Parameter: ENV_DEVICE_MODE) Restart method from Resource Block Reboot transmitter (Cycle Power)
Level Measurement Failure	Check Power Supply Check the transmitter configuration (Transducer Block) Check that the mechanical installation is correct
Temperature Measurement Failure	Check temperature electrical installation Check configuration (Transducer Block) Restart the transmitter
Volume Measurement Failure	Restart transmitter Check transmitter configuration using PC Based configuration Tool, Radar Master
No surface echo	Check signal strength Restart transmitter
Tank Signal Clip Warning	Restart transmitter
Empty Tank/ Full Tank	Information of tank status
Configuration Reg Password Enabled	Information, Ready Write Data
DB Error/ Microwave Unit Error/ Configuration Error/ Other Error	Restart transmitter Call Rosemount Service Center Download Application Software Set database to default load Database default
SW Error/ Display Error/ Analog Out Error	Restart transmitter Call Rosemount Service Center

Field Upgrades

Labeling

⚠ Each radar transmitter is labeled individually, so it is imperative that the approval codes on each label match exactly during upgrade. The label on the radar transmitter reflects the replacement model code for reordering an assembled unit. The housing labeling will only reflect the approvals and communication protocol of the housing.

Figure 8-3. Example of the Rosemount 5600 label

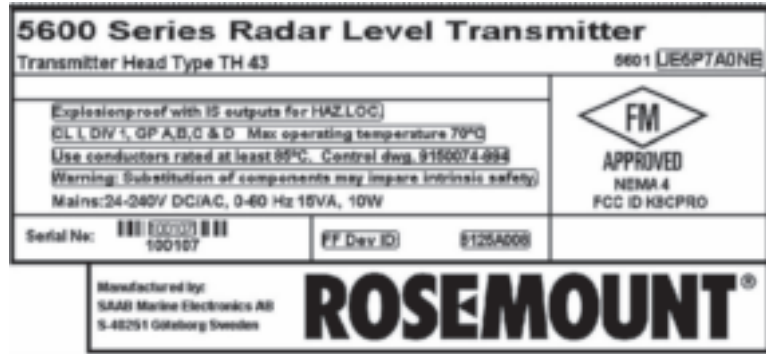

5600/LABELS/FIELDBUS/LABEL_02A.EPS

FOUNDATION Fieldbus

Rosemount 5600 Series

RESOURCE BLOCK

This section describes error conditions found in the Resource block. Read Table 8-5 through Table 8-7 to determine the appropriate corrective action.

Block Errors

Table 8-5 lists conditions reported in the BLOCK_ERR parameter.

Table 8-5. Resource Block BLOCK_ERR messages

Condition Name and Description
Other
Simulate Active: This indicates that the simulation switch is in place. This is not an indication that the I/O blocks are using simulated data
Device Fault State Set
Device Needs Maintenance Soon
Memory Failure: A memory failure has occurred in FLASH, RAM, or EEPROM memory
Lost Static Data: Static data that is stored in non-volatile memory has been lost
Lost NV Data: Non-volatile data that is stored in non-volatile memory has been lost
Device Needs Maintenance Now
Out of Service: The actual mode is out of service

Table 8-6. Resource Block SUMMARY_STATUS messages

Condition Name
Uninitialized
No repair needed
Repairable
Call Service Center

Table 8-7. Resource Block DETAILED_STATUS with recommended action messages

Condition Name	Recommended Action
LOI Transducer block error	1. Restart processor 2. Check display connection 3. Call service center
Sensor Transducer block error	1. Restart processor 2. Check Rosemount 5600 cable 3. Call service center
Mfg. Block integrity error	1. Restart processor 2. Call service center
Non-Volatile memory integrity error	1. Restart processor 2. Call service center
ROM integrity error	1. Restart processor 2. Call service center

TRANSDUCER BLOCK

This section describes error conditions found in the Sensor Transducer Block.

Table 8-8. Transducer Block BLOCK_ERR messages

Condition Name and Description	
	Other
Out of Service:	The actual mode is out of service

Table 8-9. Transducer Block XD_ERR messages

Condition Name and Description	
	Electronics Failure: An electrical component failed
	I/O Failure: An I/O failure occurred
	Data Integrity Error: Data stored in the device is no longer valid due to a non-volatile memory checksum failure, a data verify after write failure, etc.
	Algorithm Error: The algorithm used in the transducer block produced an error due to overflow, data reasonableness failure, etc.

ANALOG INPUT (AI) FUNCTION BLOCK

This section describes error conditions that are supported by the AI Block. Read Table 8-11 to determine the appropriate corrective action.

Table 8-10. AI BLOCK_ERR Conditions

Condition Number	Condition Name and Description
0	Other
1	Block Configuration Error: the selected channel carries a measurement that is incompatible with the engineering units selected in XD_SCALE, the L_TYPE parameter is not configured, or CHANNEL = zero
3	Simulate Active: Simulation is enabled and the block is using a simulated value in its execution
7	Input Failure/Process Variable has Bad Status: The hardware is bad, or a bad status is being simulated
14	Power Up
15	Out of Service: The actual mode is out of service

FOUNDATION Fieldbus

Rosemount 5600 Series

Table 8-11. Troubleshooting the AI block

Symptom	Possible Causes	Recommended Actions
Bad or no level readings (Read the AI "BLOCK_ERR" parameter)	BLOCK_ERR reads OUT OF SERVICE (OOS)	1. AI Block target mode target mode set to OOS. 2. Resource Block OUT OF SERVICE.
	BLOCK_ERR reads CONFIGURATION ERROR	1. Check CHANNEL parameter (see "CHANNEL" on page 6-10) 2. Check L_TYPE parameter (see "L_TYPE" on page 6-11) 3. Check XD_SCALE engineering units. (see "XD_SCALE and OUT_SCALE" on page 6-11)
	BLOCK_ERR reads POWERUP	Download Schedule into block. Refer to host for downloading procedure.
OUT parameter status reads UNCERTAIN and substatus reads EngUnitRangViolation	BLOCK_ERR reads BAD INPUT	1. Sensor Transducer Block Out Of Service (OOS) 2. Resource Block Out of Service (OOS)
	No BLOCK_ERR but readings are not correct. If using Indirect mode, scaling could be wrong	1. Check XD_SCALE parameter. 2. Check OUT_SCALE parameter. (see "XD_SCALE and OUT_SCALE" on page 6-11)
Mode will not leave OOS	Out_ScaleEU_0 and EU_100 settings are incorrect.	See "XD_SCALE and OUT_SCALE" on page 6-11.
Process and/or block alarms will not work	Target mode not set	Set target mode to something other than OOS.
	Configuration error	BLOCK_ERR will show the configuration error bit set. The following are parameters that must be set before the block is allowed out of OOS: CHANNEL must be set to a valid value and cannot be left at initial value of 0. XD_SCALE.UNITS_INDX must match the units in the transducer block channel value. L_TYPE must be set to Direct, Indirect, or Indirect Square Root and cannot be left at initial value of 0.
	Resource block	The actual mode of the Resource block is OOS. See Resource Block Diagnostics for corrective action.
Value of output does not make sense	Schedule	Block is not scheduled and therefore cannot execute to go to Target Mode. Schedule the block to execute.
	Features	FEATURES_SEL does not have Alerts enabled. Enable the Alerts bit.
Cannot set HI_LIMIT, HI_HI_LIMIT, LO_LIMIT, or LO_LO_LIMIT Values	Notification Status Options	LIM_NOTIFY is not high enough. Set equal to MAX_NOTIFY. STATUS_OPTS has Propagate Fault Forward bit set. This should be cleared to cause an alarm to occur.
	Linearization Type	L_TYPE must be set to Direct, Indirect, or Indirect Square Root and cannot be left at initial value of 0.
Cannot set HI_LIMIT, HI_HI_LIMIT, LO_LIMIT, or LO_LO_LIMIT Values	Scaling	Scaling parameters are set incorrectly: XD_SCALE.EU0 and EU100 should match that of the transducer block channel value. OUT_SCALE.EU0 and EU100 are not set properly.
	Scaling	Limit values are outside the OUT_SCALE.EU0 and OUT_SCALE.EU100 values. Change OUT_SCALE or set values within range.

Appendix A Reference Data

Specifications	page A-1
Dimensional Drawings	page A-8
Ordering Information	page A-13

SPECIFICATIONS

General

Product Designation

5600 Series Radar Level Transmitter

Operating Principle

10GHz FMCW radar

Beam Angle

See Figure 2-12 and Table 2-3 on page 2-9

Microwave Output Power

Max 1.0 mW

Internal Calibration

Internal digital reference for automatic compensation of radar sweep

Signal Processing

Powerful and advanced digital signal processing using FFT and advanced echo handling software

Measuring Performance

Instrument Accuracy (Under reference conditions)

±0.2 in (±5 mm)

Resolution

0.04 in (1 mm)

Temperature Stability

± 500 ppm of measured distance within the ambient temperature range\

Repeatability

±0.04 in (±1 mm)

Measuring Range

0-164 ft (0-50 m)

Update Time

100 ms

Rosemount 5600 Series

Display/Configuration

Processors

32-bit Floating DSP

PC/remote Configuration

Rosemount Radar Master, Powerful and Interactive Windows based configuration tool.

Recommended PC hardware specification: ≥ 1 GHz processor, ≥ 128 MbRam, Operating system of Win 2000, Win XP, or Win NT.

To communicate with the device using Radar Master either a HART or Modbus Modem (RS485 Sensor Bus Port) is required for the PC.

For fieldbus devices Radar Master can only be connected to the Sensor Bus Port (see listed Modems on page A-19).

See "PC Configuration Software Radar Master" on page 5-2 for additional information.

HART Device

Emerson Process Management 375 Field Communicator

Emerson Process Management AMS software

See "Hand-Held Communicator" on page 5-7 for additional information.

Display (factory mounted on transmitter)

Protection class IP67

With weather/dirt protection cover; graphical LCD display 128 by 64 pixels with 4 control soft-keys and 7 text lines with 16 characters/line for display and configuration.

Display (remote mounted)

Same as above, mounted in separate enclosure, protection class IP67; max cable length, display - radar transmitter: 330 ft. (100 m); cable type: 4 wire shielded instrument cable, min. 0.5 mm², (AWG 20).

Display with Temperature Inputs (remote mounted)

Same as above, mounted in separate enclosure, protection class IP67; max cable length, display - radar transmitter: 330 ft (100 m); cable type: 4 wire shielded instrument cable, min. 0.5 mm², (AWG 20); temperature measurement 1-3 spot elements PT100 or CU100, or 6 spot elements with common return.

Electric

Power Supply

Ultra wide power supply 24-240 V AC or DC 0-60 Hz



NOTE

Minimum power required at the transmitter power terminals is 20 W.

Power Consumption

Maximum 10 W, Nominal 5 W

Outputs

Primary Output:

Alternative 1: HART + 4-20 mA current loop
(non-IS or IS option)

Alternative 2: FOUNDATION fieldbus (non-IS or IS option)

Secondary Outputs:

Analog 4-20 mA current loop, active or passive
(non-IS or IS option)

Output Cabling

Twisted and shielded pair; min. 0.5 mm² (AWG 20)

Cable Entries

3 × 1/2 inch NPT; for cable glands or conduit entries

Optional: 1/2 inch NPT Cable Gland Kit

Optional: 1/2 inch NPT/ M20 Adapters (Set of 3)

Remote 2210 Display Unit⁽¹⁾

2 × M20 entries

1 × M25 entry

**Analog Output
Characteristics**

Type

Analog 4-20 mA Current Loop, active (with power supplied by the 5600) or passive (for external loop-supplied power)

Galvanic Isolation

> 1500 V RMS or DC

Analog Output Electrical Characteristics

See "Product Certifications" on page B-1

Range

4-20 mA

Alarm Level

Standard: Low=3.8 mA, High=22 mA or freeze,
NAMUR NE43: High=22.50 mA,
Rosemount: Low=3.75 mA

(1) US and Canada markets are supplied with 1/2-in. and 3/4-in. adapters.

Rosemount 5600 Series

Accuracy

$\pm 300\mu\text{A}$ at 4 mA
 $\pm 600\mu\text{A}$ at 20 mA

Resolution

$0.5\mu\text{A}$ (0.003%)

Linearity

$\pm 0.01\%$

Temperature Drift

± 28 ppm/ $^{\circ}\text{F}$ (± 50 ppm/ $^{\circ}\text{C}$)

Output Impedance

$>10\text{ M}\Omega$

Voltage Compliance

7-30 V (passive output)

External Loop Resistance

$<700\ \Omega$ (passive output with 24 V external supply)

$<300\ \Omega$ (active output)

**Fieldbus Output
Characteristics****Type**

Function blocks available in the device are:

- 1 Level Transducer Block
- 1 Register Transducer Block
- 6 Analog Input Blocks

Fieldbus Output Electrical Characteristics

Fieldbus Voltage limits: 9 to 32 V

Current Draw: 12.5 mA

For I.S. Applications:

$U_i < 30\text{ V}$

$I_i < 300\text{ mA}$

$P_i < 1.3\text{ W}$

$C_i = 0\ \mu\text{F}$

$L_i = 0\text{ mH}$

Lift-off Minimum Voltage

9.0 V

Class

Link Master (LAS)

Number of Available VCRs

20

VCR Statistics

Yes

Execution Time
60 ms for AI-block

Instantiation
Yes (all activated)

Available Menus and Methods

Transducer Block
Configure Gauge, Restart Device, Set to Factory Defaults, Sensor Bus

Resource Function Block
Master Reset

Conforming Foundation™ fieldbus
ITK 4.6

Advanced Diagnostics

Failures
Level, Temperature and Volume measurement failure

Warnings
Empty tank, Full tank, Database, Hardware, Software and Configuration warnings

Errors
Database, Hardware, Software and Configuration warnings

2210 Display Unit Output Characteristics

With Temperature Output
See “Product Certifications” on page B-1

Without Temperature Output
See “Product Certifications” on page B-1

Temperature Measurement
1-3 spot elements, PT100 or CU100, or 6 spot elements with common return.
Input accuracy $\pm 0.9^{\circ}\text{F}$ ($\pm 0.5^{\circ}\text{C}$)

Temperature Measurement Output
Average temperature or individual spots ⁽¹⁾

(1) Individual spots not available in Foundation fieldbus devices

Rosemount 5600 Series

Mechanical

Housing/Enclosure

Permanent moulded cast aluminium, chromed and powder painted

Flanges

ANSI, DIN standard,

Material: Stainless steel 316L and Stainless Steel EN 1.4404

Optional: Hot-galvanized carbon steel

Weight, Excluding, Flange

18 lbs (8 kg)

Height Above Flange

15 in (400 mm)

Antenna Dimensions

Cone: See Figure A-2 on page A-8

Rod: See Figure A-1 on page A-8

Process Seal: See Figure A-4 and Table A-2 on page A-10

Extended Cone: See Figure A-5 on page A-11

Cone with Integrated Flushing Connection:

See Figure A-6 on page A-11

Parabolic: See Figure A-7 on page A-12

TABLE 1. Antenna material and o-ring selection ● Applicable - Not applicable

	Rod Antenna	Cone Antenna	Process Seal Antenna	Extended Cone Antenna	Cone with Integrated Flushing Connection	Parabolic Antenna
Material:						
Stainless Steel 316L	● ⁽¹⁾	●	-	●	●	●
Hastelloy® C22	-	●	-	-	-	-
Titanium Gr1/Gr2	-	●	-	-	-	-
Tantalum	-	●	-	-	-	-
Monel® 400	-	●	-	-	-	-
PTFE	● ⁽¹⁾	-	●	-	-	-
Tank Seal:						
PTFE	-	●	-	●	●	●
Quartz	-	●	-	●	●	-
O-Rings:						
Viton	●	●	-	●	●	●
Kalrez	●	●	-	●	●	-
EPDM	●	●	-	●	●	-
Buna-N	●	●	-	●	●	-

(1) The wetted parts of the Rod Antenna consists of both 316L SST (inactive part) and PTFE.

Environment

Ambient Temperature

-40 to 158°F (-40 to 70°C)

LCD Readable between: -4 to 158°F (-20 to 70°C)

Process Temperature Range ⁽¹⁾

-40 up to 752°F (-40 up to 400°C), depending on antenna style

Flange Temperature Range ⁽¹⁾

TABLE 2. Flange Temperature Range depending on O-ring selection

O-ring Material	Minimum Temperature °F (°C) in air	Maximum Temperature F (°C) in air
Viton	5 (-15)	392 (200)
Ethylene Propylene (EPDM)	-40 (-40)	266 (130)
Kalrez 6375	-4 (-20)	527 (275)
Buna-N	-31 (-35)	230 (110)

Pressure Range ⁽¹⁾

Full vacuum up to +798 psig (+55 bar), depending on antenna style

Emission Approvals

FCC: K8CPRO, K8CPROX

R&TTE: E813268O-CC

Humidity

IEC 60068-2-3

Climatic Class/Corrosion Class

IEC 68-2-1, IEC 60068-2-52 test KB severity 2

Ingress Protection

IP66, IP 67 and NEMA 4

Vibration

IEC 721-3-4 class 4M4

UV Protection

ISO 4892-2

Electromagnetic Compatibility

EN61326-1: 1997 incl A1:1998 and A2:2001, Immunity 50081-2, Emission 50081-1

Lightning Protection

EN61326, EN61000-4-5, IEC801-5, level 2 kV

Power Supply Fluctuation

IEC 92 Part 504 sec. 3.5

(1) See Figure A-1, Figure A-2, Figure A-4, Figure A-5, Figure A-6, and Figure A-7 for specification of each antenna.

Rosemount 5600 Series

DIMENSIONAL DRAWINGS

Figure A-1. Rod Dimensions

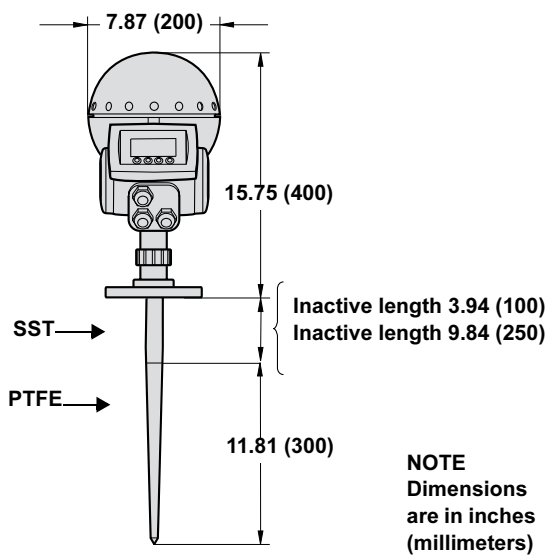

NOTE
Dimensions are in inches (millimeters)

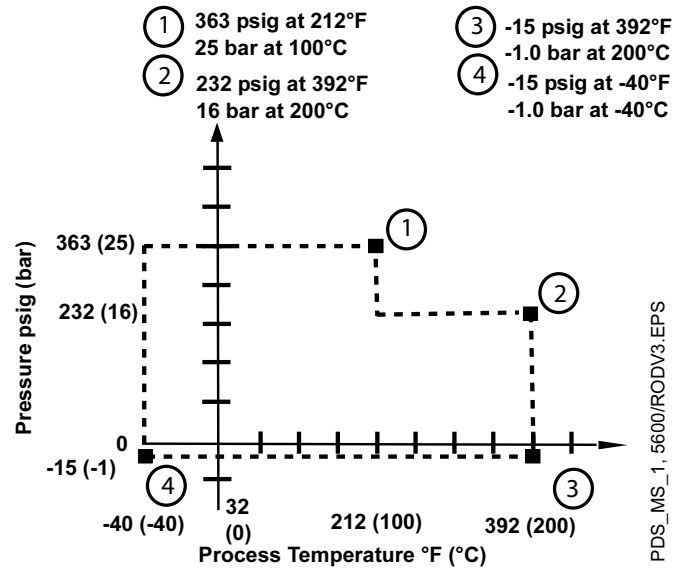

PDS_MS_1_5600/RODV3.EPS

Note: Pressure rating may be lower depending on flange selection.
Minimum / maximum flange temperature rating depends on O-ring selection (See Table A-1 and Figure A-3 on page A-9).

Figure A-2. Cone Dimensions

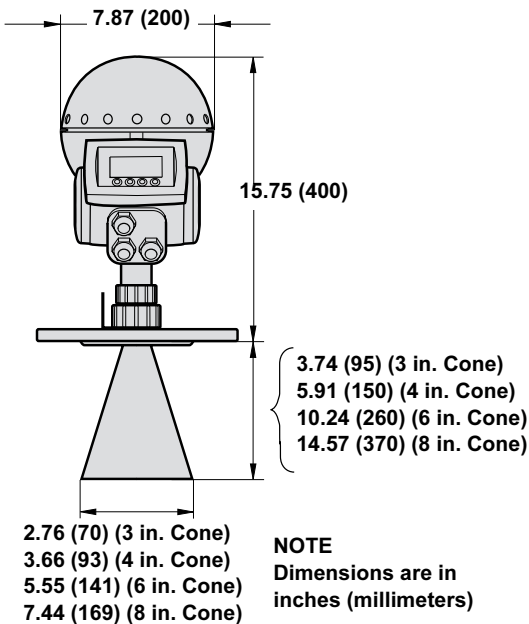

NOTE
Dimensions are in inches (millimeters)

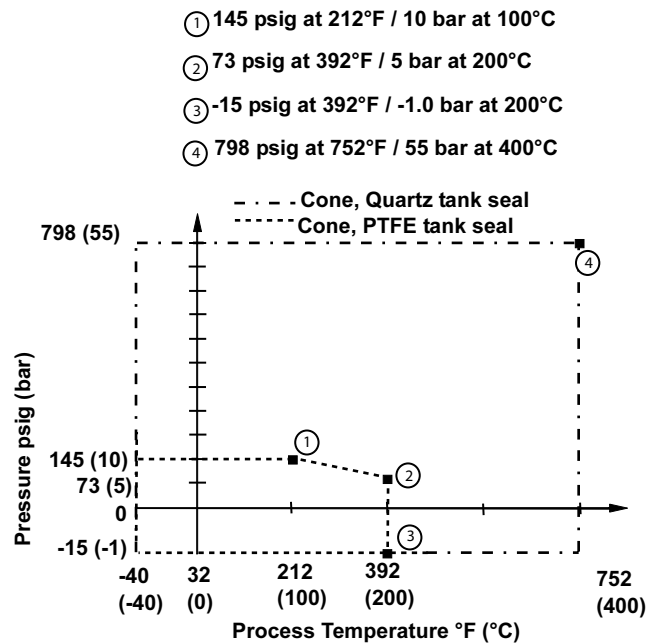

5600/PDS/MS_2_5600/5600_ROD_GRAPHAB.EPS

Note: Pressure rating may be lower depending on flange selection.
Minimum / maximum flange temperature rating depends on O-ring selection (See Table A-1 and Figure A-3 on page A-9).

Table A-1. Flange Temperature Range depending on O-ring selection

O-ring Material	Minimum Temperature °F (°C) in air	Maximum Temperature F (°C) in air
Viton	5 (-15)	392 (200)
Ethylene Propylene (EPDM)	-40 (-40)	266 (130)
Kalrez 6375	-4 (-20)	527 (275)
Buna-N	-31 (-35)	230 (110)

Figure A-3. Temperature Rating Considerations

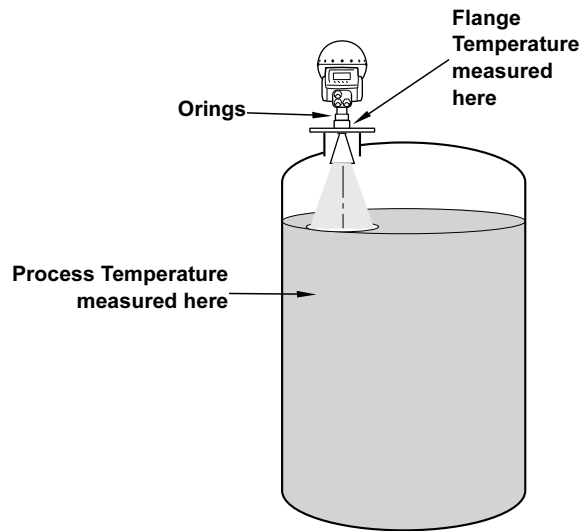

5600FA_01.EPS

Note
 Flange temperature depends on mounting conditions, such as nozzle position, distance to max product level, nozzle height, presence of insulation, etc.

Rosemount 5600 Series

Figure A-4. Process Seal Dimensions

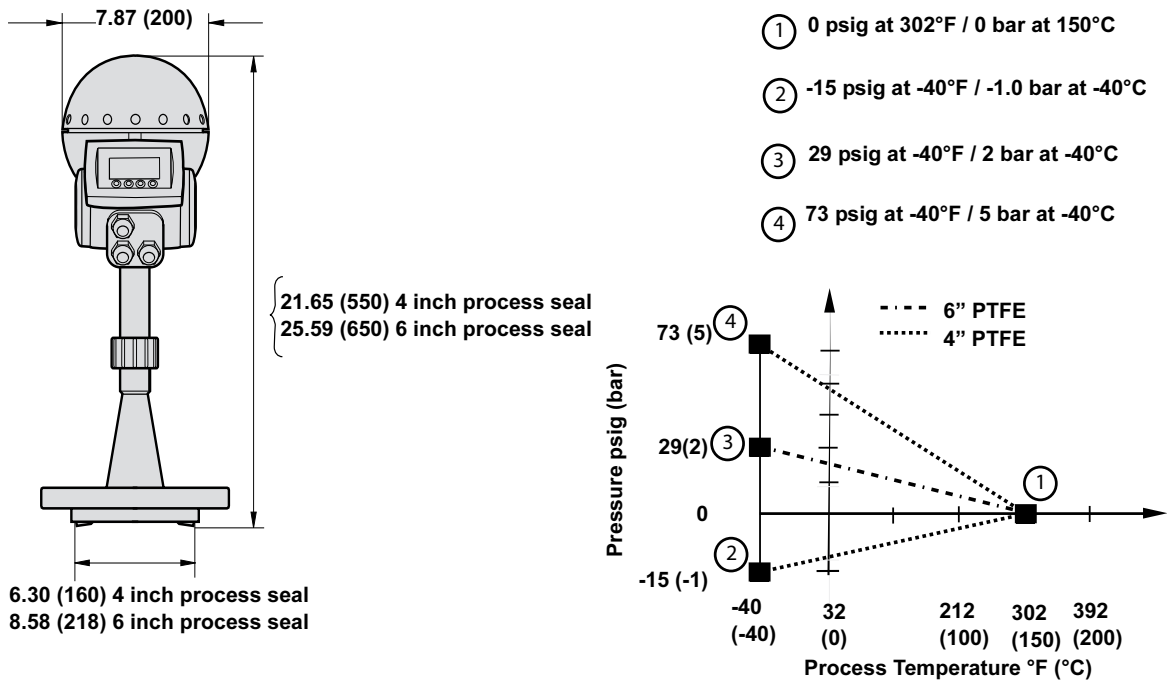

5600/PDS/MS_4.EPS_5600/5600_PROCESS_GRAPH.IEPS

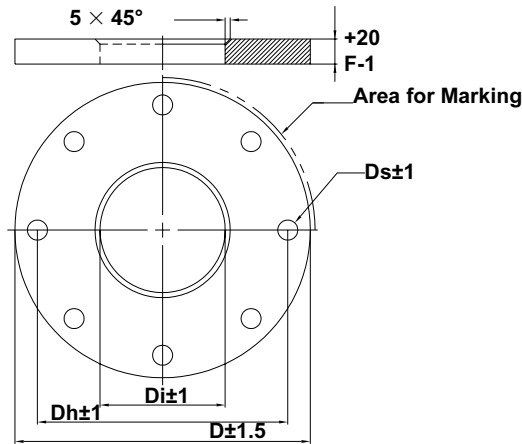

5600_D.D._9150070836AA

Note
 Dimensions are in inches (millimeters)

Table A-2. Dimensions for Stainless Steel Flange and Galvanized Carbon Steel. Dimensions are in inches (millimeters)

Flange	Di	D	Dh	Ds	F
ANSI 4 inch Class 150	3.78 (96)	9.02 (229)	7.52 (191)	0.87 (22)	0.87 (22)
ANSI 6 inch Class 150	4.94 (125.5)	10.98 (279)	9.49 (241)	0.87 (22)	0.87 (22)
DN100 PN16	3.78 (96)	8.66 (220)	7.09 (180)	0.71 (18)	0.87 (22)
DN150 PN16	4.94 (125.5)	11.22 (285)	9.45 (240)	0.87 (22)	0.87 (22)

Figure A-5. Extended Cone Dimensions for Stainless Steel Flange

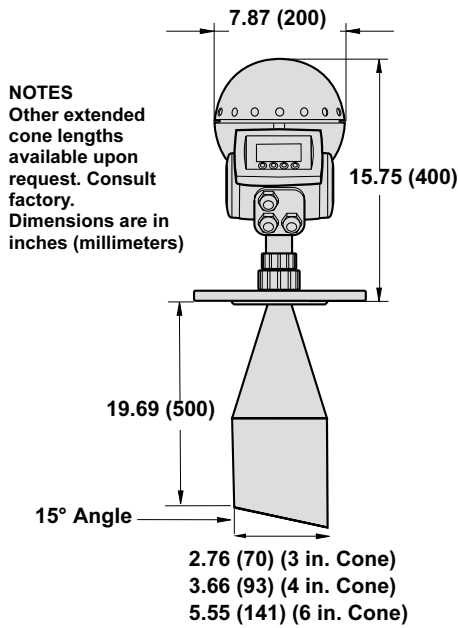

NOTES
Other extended cone lengths available upon request. Consult factory. Dimensions are in inches (millimeters)

- ① 145 psig at 212°F / 10 bar at 100°C
- ② 73 psig at 392°F / 5 bar at 200°C
- ③ -15 psig at 392°F / -1.0 bar at 200°C
- ④ 798 psig at 752°F / 55 bar at 400°C

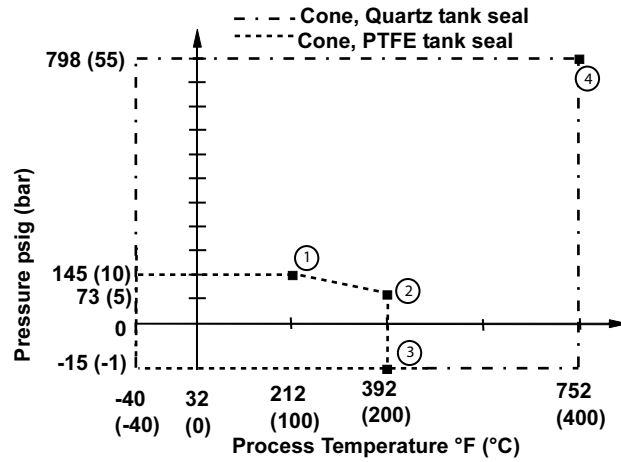

5600/PDS/MS_2_5600/VST1V2-405-PAGE6.EPS

Note: Pressure rating may be lower depending on flange selection.
Minimum / maximum flange temperature rating depends on O-ring selection (See Table A-1 and Figure A-3 on page A-9).

Figure A-6. Cone with Integrated Flushing Connection Dimensions for Stainless Steel Flange

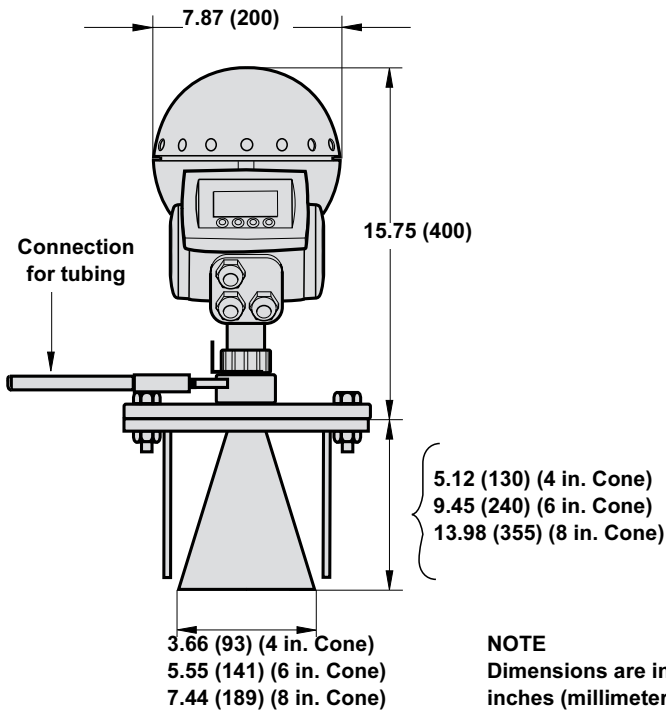

Maximum: 145 psig at 392°F (10bar at 200°C).
See Table A-9 on page A-17 for additional information.

NOTE
Dimensions are in inches (millimeters)

Note: Pressure rating may be lower depending on flange selection.
Minimum / maximum flange temperature rating depends on O-ring selection (See Table A-1 and Figure A-3 on page A-9).

5600_PDS_MS_2C.EPS

Rosemount 5600 Series

Figure A-7. Parabolic Dimensions for Stainless Steel Flange

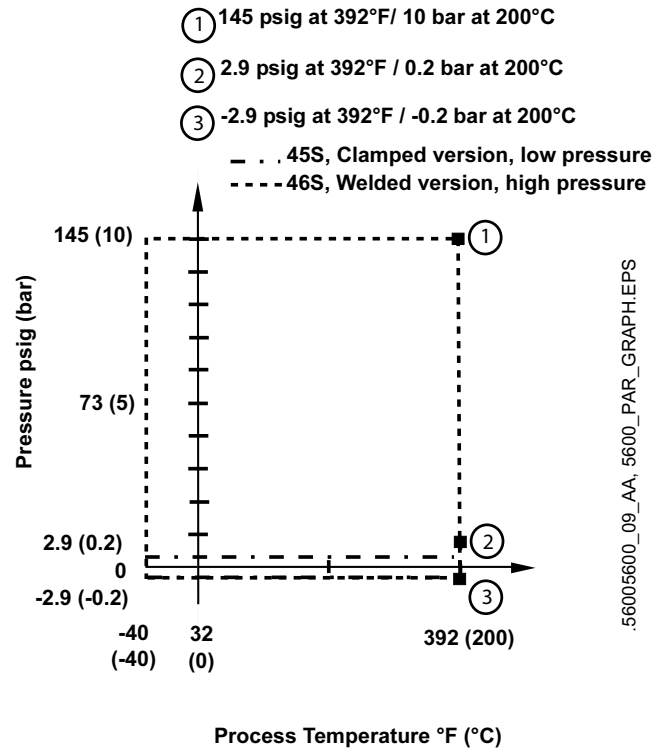
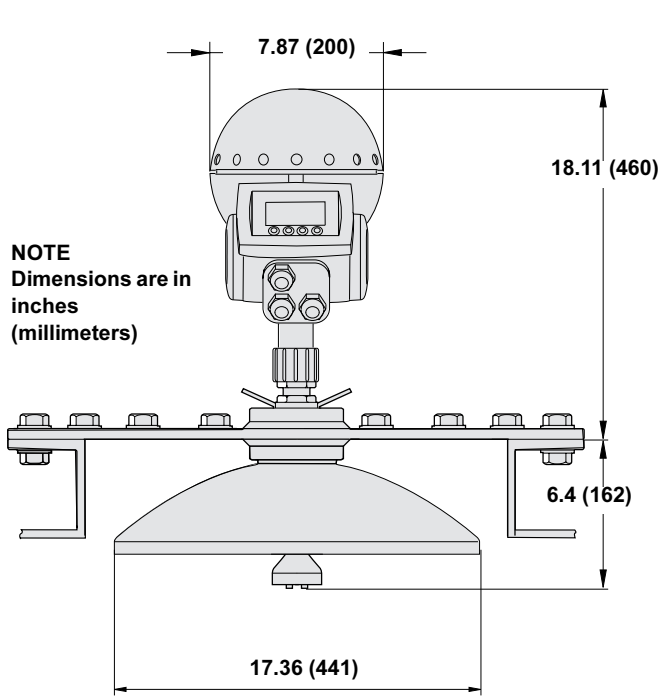

.56005600_09_AA_5600_PAR_GRAPH.EPS

**ORDERING
INFORMATION**

Table A-3. Rosemount 5600 Radar Transmitter Selection

Model	Product Description
5601	Radar Level Transmitter for Process Applications
Code	Frequency Band
U	US Market Only (10 GHz)
S	Switzerland Market Only (10 GHz)
A	All Other Markets (10 GHz)
Code	Product Certification
NA	None
E1	ATEX Flameproof
E5	FM Explosionproof
E6	CSA Explosionproof
Code	Power Supply
P	24-240 V DC/AC 0-60 Hz
Code	Primary Output
5A	4-20 mA with HART communication, Passive Output
5B	4-20 mA with HART communication, Passive Output, Intrinsically Safe Circuit ⁽¹⁾
5C	4-20 mA with HART communication, Active Output
5D	4-20 mA with HART communication, Active Output, Intrinsically Safe Circuit ⁽¹⁾
7A	Foundation Fieldbus
7B	Foundation Fieldbus, Intrinsically Safe Circuit ⁽¹⁾
Code	Secondary Output
0	None
1	4-20 mA, Passive Output ⁽²⁾
2	4-20 mA, Passive Output, Intrinsically Safe Circuit ⁽¹⁾
3	4-20 mA, Active Output ⁽²⁾
4	4-20 mA, Active Output, Intrinsically Safe Circuit ⁽¹⁾
Code	Display Unit
N	None
P	LOI, Factory mounted on transmitter
R	LOI, Remote mounted
T	LOI, Remote mounted with temp inputs (1-6 spot elements with common returns)
Code	Volume Calculation
E	Basic Volume Equations (Standard)
V	Strapping Table, up to 100 points
Typical Model Number: 5601 S E1 P 5A 0 P E Antenna Selection ⁽³⁾	

(1) Intrinsically safe circuit only applicable if product certificate codes E1, E5, or E6 is selected.
(2) Not allowed in combination with Display Unit codes P, R, or T.
(3) Select the antenna type and options using Table A-4, Table A-5, Table A-6, Table A-8, and Table A-9.

Rosemount 5600 Series

Table A-4. Rod Antenna

Code	Antenna Type	Antenna Size	Antenna Material	Note
Rod				
11S		1.5 in. threaded version	SST 316L and PTFE	Inactive Length 4 inch (100 mm)
12S		2 in. (DN50) nozzles	SST 316L and PTFE	Inactive Length 4 inch (100 mm)
13S		3 in. (DN80) nozzles	SST 316L and PTFE	Inactive Length 4 inch (100 mm)
14S		4 in. (DN100) nozzles	SST 316L and PTFE	Inactive Length 4 inch (100 mm)
11L		1.5 in. threaded version	SST 316L and PTFE	Inactive Length 10 inch (250 mm)
12L		2 in. (DN50) nozzles	SST 316L and PTFE	Inactive Length 10 inch (250 mm)
13L		3 in. (DN80) nozzles	SST 316L and PTFE	Inactive Length 10 inch (250 mm)
14L		4 in. (DN100) nozzles	SST 316L and PTFE	Inactive Length 10 inch (250 mm)
1XX		Customer specific rod or material		Consult Factory
Code		Tank Seal		
N		Not Applicable		
Code		O-ring Material		
V		Viton		
K		Kalrez 6375		
E		EPDM		
B		Buna-N		
Code		Process Connection		
NR		Antenna with Plate Design <i>NOTE: Customer supplied flange or see Table A-13 on page A-19 for flange options</i>		
XX		Special Process Connection		Consult Factory
		Threaded Version		
TN		Threaded 1.5 in. NPT		
TB		Threaded 1.5 in. G		
Code		Options		
Q8		Material Traceability Certification per EN 10204 3.1.B		
Typical Model Number: Selected code from Table A-3 on page A-13 11S N F TN				

Table A-5. Cone Antenna

Code	Antenna Type	Antenna Size	Antenna Material	Note
Cone				
23S		3 in. (DN80) nozzles	SST 316L	Pipe Installation Only
24S		4 in. (DN100) nozzles	SST 316L	Free propagation or 4" pipe
26S		6 in. (DN150) nozzles	SST 316L	Free propagation or 6" pipe
28S		8 in. (DN200) nozzles	SST 316L	Free propagation only
23H		3 in. (DN80) nozzles	Hastelloy C22	Longer Lead-time, Consult Factory
24H		4 in. (DN100) nozzles	Hastelloy C22	Longer Lead-time, Consult Factory
26H		6 in. (DN150) nozzles	Hastelloy C22	Longer Lead-time, Consult Factory
28H		8 in. (DN200) nozzles	Hastelloy C22	Longer Lead-time, Consult Factory
23T		3 in. (DN80) nozzles	Titanium Gr 1/2	Longer Lead-time, Consult Factory
24T		4 in. (DN100) nozzles	Titanium Gr 1/2	Longer Lead-time, Consult Factory
26T		6 in. (DN150) nozzles	Titanium Gr 1/2	Longer Lead-time, Consult Factory
28T		8 in. (DN200) nozzles	Titanium Gr 1/2	Longer Lead-time, Consult Factory
23M		3 in. (DN80) nozzles	Monel 400	Longer Lead-time, Consult Factory
24M		4 in. (DN100) nozzles	Monel 400	Longer Lead-time, Consult Factory
26M		6 in. (DN150) nozzles	Monel 400	Longer Lead-time, Consult Factory
28M		8 in. (DN200) nozzles	Monel 400	Longer Lead-time, Consult Factory
23Z		3 in. (DN80) nozzles	Tantalum	Longer Lead-time, Consult Factory
24Z		4 in. (DN100) nozzles	Tantalum	Longer Lead-time, Consult Factory
26Z		6 in. (DN150) nozzles	Tantalum	Longer Lead-time, Consult Factory
28Z		8 in. (DN200) nozzles	Tantalum	Longer Lead-time, Consult Factory
2XX		Customer specific cone or material		Consult Factory
Code	Tank Seal			
P	PTFE			
Q	Quartz			
Code	O-ring Material			
V	Viton			
K	Kalrez 6375			
E	EPDM			
B	Buna-N			
Code	Process Connection			
NR	Antenna with Plate Design <i>NOTE: Customer supplied flange or see Table A-13 on page A-19 for flange options</i>			
XX	Special Process Connection			Consult Factory
Code	Options			
Q8	Material Traceability Certification per EN 10204 3.1.B			
Typical Model Number: Selected code from Table A-3 on page A-13 24S P V NR				

Rosemount 5600 Series

Table A-6. Process Seal Antenna

Code	Antenna Type	Antenna Size	Antenna Material	Note
Process Seal				
34S		4 in. (DN100) nozzles	PTFE	
36S		6 in. (DN150) nozzles	PTFE	
Code Tank Seal				
P		PTFE		
Code O-ring Material				
N		Not Applicable		
Code Process Connection				
NF		None, Customer to supply flange per dimensions on Figure A-4		
XX		Special Process Connection		Consult Factory
Stainless Steel Flange				
CA		4 in. ANSI Class 150		
DA		6 in. ANSI Class 150		
JA		DN100 PN16		
KA		DN150 PN16		
Galvanized Carbon Steel Flange				
CC		4 in. ANSI Class 150		Longer Lead-Time, Consult Factory
DC		6 in. ANSI Class 150		Longer Lead-Time, Consult Factory
JC		DN100 PN16		Longer Lead-Time, Consult Factory
KC		DN150 PN16		Longer Lead-Time, Consult Factory
Code Options				
Q8		Material Traceability Certification per EN 10204 3.1.B		
Typical Model Number: Selected code from Table A-3 on page A-13 34S P N JA				

Table A-7. Parabolic Antenna

Code	Antenna Type	Antenna Size	Antenna Material	Note
Parabolic				
45S		ø18 in. (440mm)	316 SST with Integrated Inclination	Clamped version (low pressure)
46S		ø18 in. (440mm)	316 SST with Integrated Inclination	Welded version (high pressure)
4XX		Customer Specific	Customer Specific	Consult Factory
Code Tank Seal				
P		PTFE		
Code O-ring Material				
V		Viton		
Code Process Connections				
NF		None, Flange Ready		
XX		Special Process Connection		Consult Factory
Code Options				
Q8		Material Traceability Certification per EN 10204 3.1.B		
Protective Cover				
PB		PTFE Protective Cover (PTFE Bag)		
Typical Model Number: Selected code from Table A-3 on page A-13 45S P V NR				

Table A-8. Extended Cone Antenna

Code	Antenna Type	Antenna Size	Antenna Material	Note
Extended				
73S		3 in. (DN80) nozzles	SST 316L	Standard length 20 inch (500 mm)
74S		4 in. (DN100) nozzles	SST 316L	Standard length 20 inch (500 mm)
76S		6 in. (DN150) nozzles	SST 316L	Standard length 20 inch (500 mm)
7XX		Customer specific extended cone or material		Consult Factory
Code		Tank Seal		
P		PTFE		
Q		Quartz		
Code		O-ring Material		
V		Viton		
K		Kalrez 6375		
E		EPDM		
B		Buna-N		
Code		Process Connections		
NR		Antenna with Plate Design <i>NOTE: Customer supplied flange or see Table A-13 on page A-19 for flange options</i>		
XX		Special Process Connection Consult Factory		
Code		Options		
Q8		Material Traceability Certification per EN 10204 3.1.B		
Typical Model Number: Selected code from Table A-3 on page A-13 76S P V NR				

Table A-9. Cone Antenna with Integrated Flushing Connection

Code	Antenna Type	Antenna Size	Antenna Material	Note
Cone with Integrated Flushing Connection				
94S		4 in. (DN100) nozzles	SST 316L	Consult Factory
96S		6 in. (DN150) nozzles	SST 316L	Consult Factory
98S		8 in. (DN200) nozzles	SST 316L	Consult Factory
Code		Tank Seal		
P		PTFE		
Q		Quartz		
Code		O-ring Material		
V		Viton		
K		Kalrez 6375		
E		EPDM		
B		Buna-N		
Code		Process Connection		
XX		Special Process Connection Consult Factory		
Stainless Steel Flange Welded to Antenna				
CL		4 in. ANSI Class 150		Max 101 psig at 392°F (7 bar at 200°C)
DL		6 in. ANSI Class 150		Max 145 psig at 392°F (10 bar at 200°C)
FL		8 in. ANSI Class 150		Max 145 psig at 392°F (10 bar at 200°C)
JL		DN100 PN16		Max 72 psig at 392°F (5 bar at 200°C)
KL		DN150 PN16		Max 87 psig at 392°F (6 bar at 200°C)
LL		DN200 PN16		Max 87 psig at 392°F (6 bar at 200°C)
Code		Options		
Q8		Material Traceability Certification per EN 10204 3.1.B		
Typical Model Number: Selected code from Table A-3 on page A-13 94S P K KL				

Rosemount 5600 Series

Table A-10. Transmitter Options (multiple selections allowed)

Code	Options
	Material Traceability Certification
Q8	Material Traceability Certification per EN 10204 3.1B
	Calibration Data Certification
Q4	Calibration Data Certificate
	Software Configuration
C1	Custom Software Configuration (CDS required with order)
	Alarm Limits
C4	NAMUR Alarm Level, High Alarm
C8	Low Alarm (Standard Rosemount Alarm)
	Conduit Adapters
G1	1/2 inch NPT Cable Gland Kit
G2	1/2 inch NPT/ M20 Adapters (Set of 3)
	Conduit Electrical Connector
GE	M12, 4-pin, Male Connector (eurofast)
GM	A size Mini, 4-pin, Male Connector (minifast)
	Special Procedures
P1	Hydrostatic Testing
	Protective Cover
PB ⁽¹⁾	Protective Cover (PTFE Bag)

(1) *Parabolic antenna only.*

Table A-11. Typical Model Code Examples

5601 A E1 P 5A 0 P E 24S P V NR

ATEX approval, passive HART primary output and display mounted on transmitter. Basic Volume calculation. Antenna is a 4 inch Cone, SST with PTFE Seal and Viton O-rings. No options.

5601 U E5 P 7A 2 T V 94S P K CL C1

FM approval, FOUNDATION™ fieldbus output and remote mounted display with temp inputs and a secondary 4-20mA passive IS output. Volume table with up to 100 points. 4 inch Cone Antenna with integrated cleaning, PTFE seal and kalrez o-rings for high temperature and pressure. Flange is ANSI 4 inch Class 150 stainless steel. Custom configuration selected.

Accessories

Table A-12. Accessories Part Numbers

Part Number	Description	Note
Modems		
03300-7004-0001	HART Modem and cables	Viator by MACTek
03300-7004-0002	HART USB Modem and cables	Viator by MACTek
05600-5004-0001	K2 RS485 Modbus Modem	For Sensor Bus Port connection
Antenna Accessories		
05600-5001-0001	PTFE Protective Cover (PTFE Bag)	For Parabolic Antenna only

Rod and Cone Antenna Flanges

Table A-13. Non-welded Flange Part Numbers

Stainless Steel Flanges			
Part Number	Flange Size	Dimensions	Material
05600-1811-0211	ANSI 2 inch Class 150	Acc. To ANSI B16.5	SST 316L ⁽¹⁾
05600-1811-0231	ANSI 2 inch Class 300	Acc. To ANSI B16.5	SST 316L ⁽¹⁾
05600-1811-0311	ANSI 3 inch Class 150	Acc. To ANSI B16.5	SST 316L
05600-1811-0331	ANSI 3 inch Class 300	Acc. To ANSI B16.5	SST 316L
05600-1811-0411	ANSI 4 inch Class 150	Acc. To ANSI B16.5	SST 316L
05600-1811-0431	ANSI 4 inch Class 300	Acc. To ANSI B16.5	SST 316L
05600-1811-0611	ANSI 6 inch Class 150	Acc. To ANSI B16.5	SST 316L
05600-1811-0811	ANSI 8 inch Class 150	Acc. To ANSI B16.5	SST 316L
05600-1810-0231	DN50 PN40	Acc. To EN 1092-1	EN 1.4404 ⁽²⁾
05600-1810-0311	DN80 PN16	Acc. To EN 1092-1	EN 1.4404 ⁽²⁾
05600-1810-0331	DN80 PN40	Acc. To EN 1092-1	EN 1.4404 ⁽²⁾
05600-1810-0411	DN100 PN16	Acc. To EN 1092-1	EN 1.4404 ⁽²⁾
05600-1810-0431	DN100 PN40	Acc. To EN 1092-1	EN 1.4404 ⁽²⁾
05600-1810-0611	DN150 PN16	Acc. To EN 1092-1	EN 1.4404 ⁽²⁾
05600-1810-0811	DN200 PN16	Acc. To EN 1092-1	EN 1.4404 ⁽²⁾
Galvanized Carbon Steel Flanges (Note: Longer Lead-time, Consult Factory)			
Part Number	Flange Size	Dimensions	Material
05600-1811-0210	ANSI 2 inch Class 150	Acc. To ANSI B16.5	CS ⁽¹⁾
05600-1811-0230	ANSI 2 inch Class 300	Acc. To ANSI B16.5	CS ⁽¹⁾
05600-1811-0310	ANSI 3 inch Class 150	Acc. To ANSI B16.5	CS
05600-1811-0330	ANSI 3 inch Class 300	Acc. To ANSI B16.5	CS
05600-1811-0410	ANSI 4 inch Class 150	Acc. To ANSI B16.5	CS
05600-1811-0430	ANSI 4 inch Class 300	Acc. To ANSI B16.5	CS
05600-1811-0610	ANSI 6 inch Class 150	Acc. To ANSI B16.5	CS
05600-1811-0810	ANSI 8 inch Class 150	Acc. To ANSI B16.5	CS
05600-1810-0230	DN50 PN40	Acc. To EN 1092-1	CS ⁽²⁾
05600-1810-0310	DN80 PN16	Acc. To EN 1092-1	CS ⁽²⁾
05600-1810-0330	DN80 PN40	Acc. To EN 1092-1	CS ⁽²⁾
05600-1810-0410	DN100 PN16	Acc. To EN 1092-1	CS ⁽²⁾
05600-1810-0430	DN100 PN40	Acc. To EN 1092-1	CS ⁽²⁾
05600-1810-0610	DN150 PN16	Acc. To EN 1092-1	CS ⁽²⁾
05600-1810-0810	DN200 PN16	Acc. To EN 1092-1	CS ⁽²⁾

(1) Use gasket type Ia.

(2) Gasket type according to EN 1514-1 and bolting according to EN1515-2.

Rosemount 5600 Series

Reference Manual
00809-0100-4024, Rev BA
September 2005

Appendix B Product Certifications

Approved Manufacturing Locations	page B-1
European Union Directive Information	page B-1
ATEX Directive (94/9/EC)	page B-5
Ordinary Location Certification for Factory Mutual	page B-5
Canadian Registration Number (CRN)	page B-5
Hazardous Locations Certifications	page B-6
ATEX Approval Drawings	page B-9
CSA Approval Drawings	page B-13

APPROVED MANUFACTURING LOCATIONS

Saab Rosemount Tank Radar AB – Gothenburg, Sweden

EUROPEAN UNION DIRECTIVE INFORMATION

The EC declaration of conformity for all applicable European directives for this product can be found on the Rosemount website at www.rosemount.com. A hard copy may be obtained by contacting our local sales representative.

5600 Series Radar Level Transmitter

This section lists specific requirements which have to be fulfilled to secure a safe installation and use of 5600 Series Radar Level Transmitter in a hazardous area. Omission may jeopardize safety, and Emerson Process Management will not take any responsibility if requirements as listed below are not fulfilled.

Table B-1. ATEX marking and EX Certification code

ATEX Marking	Safety Coding	Outputs
⊕ II 1/2 GD	EEx de IIC T6 (-40° to +70°C)	Non-Intrinsically Safe (Non-IS) Primary and/or Secondary outputs
⊕ II (2) (1) 1/2 GD	EEx de [ib] [ia] IIC T6 (-40° to +70°C)	IS Display output. IS Primary output, and/or IS Secondary output
⊕ II (1) 1/2 GD	EEx de [ia] IIC T6 (-40° to +70°C)	IS Display output. Non-IS Primary output, and/or Non-IS Secondary output

Intrinsically safe (IS) entity parameters

The unit can be equipped with various types of outputs, each type of IS configuration has specific entity parameters. The output configuration is shown on the main label of each unit.

- Passive analog output 4-20mA, Label identification = HART passive Voltage compliance 7-30V, $U_i < 30V$, $I_i < 200mA$, $P_i < 1.3 W$, $C_i = 0\mu F$, $L_i = 0mH$.
- Active analog output 4-20mA, Label identification = HART active Max load 300Ω , $U_o = 23.1V$, $I_o = 125.7mA$, $P_o = 0.726W$, $C_{ext} < 0.14\mu F$, $L_{ext} < 2.2mH$.
- Foundation fieldbus, Label identification = Foundation Fieldbus $U_i < 30V$, $I_i < 300mA$, $P_i < 1.3W$, $C_i = 0\mu F$, $L_i = 0mH$.

Instructions specific to hazardous area installations

The 5600 Series Radar Level Transmitter has been certified to comply with Directive 94/9/EC of the European Parliament and the Council as published in the Official Journal of the European Communities no. L 100/1.

The following instructions apply to equipment covered by certificate numbers Sira03ATEX1294X:

1. The equipment may be used with flammable gases and vapors with apparatus Group IIC.
2. The Transmitter Head is certified for installation in a cat 1 area and for use in ambient temperatures in the range of $-40^{\circ}C$ to $+70^{\circ}C$ and should not be used outside this temperature range.
3. The antenna including tank seal is designed to be mounted across the boundary between a cat 1 and cat 2 area. There are various cat 1 areas within the range from $-40^{\circ}C$ to $+400^{\circ}C$, -1 to 55 bar that can be considered. It is the responsibility of the user to select the appropriate antenna including tank seal to match the tank process conditions, see Table B-2. Antenna type, size, and tank seal material can be found on the antenna label.

Table B-2.

Antenna Type	Size	Tank Seal Material	Temperature Range	Pressure Range (linear interpolation between breakpoints)
Cone Pipe	All	PTFE	-40 to +200°C	-1 to 10 bar @ -40°C -1 to 10 bar @ 100°C -1 to 5 bar @ 200°C
Cone Pipe	All	Quartz	-40 to +400°C	-1 to 55 bar
Cone/purging	All	PTFE	-40 to +200°C	-1 to 10 bar
Cone/purging	All	Quartz	-40 to +400°C	-1 to 10 bar
Process Seal	4-in. / DN100	PTFE	-40 to +150°C	-1 to 5 bar @ -40°C 0 bar @ +150°C
Process Seal	6-in. / DN150	PTFE	-40 to +150°C	-1 to 2 bar @ -40°C 0 bar @ +150°C
Rod 100 Rod 250	All	PTFE	-40 to +200°C	25 bar @ -40°C 25 bar @ 100°C 16 bar @ 200°C
Parabolic Parabolic	18-in. / Welded 18-in. / Clamped	PTFE	-40 to +230°C -40 to +230°C	-1 to 10 bar -0.5 to 0.5 bar

4. The product must be installed by suitably trained personnel and carried out in accordance with all appropriate international, national, and local standard codes of practice and site regulations for intrinsically safe apparatus and in accordance with the instructions contained within this manual.
5. Repair of this equipment shall be carried out by the manufacturer or in accordance with the applicable code of practice.
6. All externally connected intrinsically safe apparatus must comply with the specified IS entity parameters.
7. The Flameproof/Explosionproof enclosure may not be opened while energized.
8. The certificate marking is detailed on drawing numbers 9150076-931 and 9150076-932.
9. The certificate has special conditions for safe use associated with it, denoted by the X on the end of the certificate no., which must be observed when the equipment is installed.
10. The certification of this equipment relies on the following materials used in its construction:
 If the equipment is likely to come into contact with aggressive substances, then it is the responsibility of the user to take suitable precautions that prevent it from being adversely affected, thus ensuring that the type of protection is not compromised.
 Aggressive substances - e.g. solvents that may affect polymeric materials.
 Suitable precautions - e.g. regular checks as part of routine inspections or establishing from the material's data sheet that it is resistant to specific chemicals.

Special Conditions for Safe Use (X)

1. As alloys may be used as the enclosure (or other parts) material and be at the accessible surface of this equipment, in the event of rare incidents, ignition sources due to impact and friction sparks could occur. This shall be considered when the equipment is being installed in locations that specifically require group II, category 1G equipment.
2. Under certain extreme circumstances, the non-metallic parts of the equipment may be capable of generating an ignition-capable level of electrostatic charge. Therefore, when used for applications that specifically require group II, category 1 equipment, the equipment shall not be installed in a location where the external conditions are conducive to the build-up of electrostatic charge on such surfaces. Additionally, the equipment non-metallic parts shall only be cleaned with a damp cloth.

2210 Display Unit

The 2210 Display Unit can be installed as a remote mounted local readout unit for a 5600 Series Radar Level Transmitter or be factory mounted attached directly to the Radar Level Transmitter head enclosure. The remote version has an optional I/O terminal card TP40 for temperature measurement.

The 2210 Display unit is certified to comply with Directive 94/9/EC of the European Parliament and the Council as published in the Official Journal of the European Communities No. L 100/1.

ATEX Marking and EX Certification code

Table B-3. ATEX marking and EX Certification code

	ATEX Marking	Safety Coding
2210 DU without TP40	⊕ II 2 G	EEx ib IIC T4 (-40° to +70°C)
2210 DU including TP40	⊕ II (2) (1) G	EEx ib [ia] IIC T4 (-40° to +70°C)

Intrinsically Safe (IS) Entity Parameters

- Connector X2: $U_i = 12V$, $I_i = 400mA$, $P_i = 0.7W$
- Optional TP40, connector X17 and X18: $U_o = 5.88V$, $I_o = 172.4mA$, $P_o = 0.253W$

The capacitance or either the inductance or the inductance to resistance (L/R) ratio of the cable connected to the connectors X17 and X18 must not exceed the following values:

Table B-4.

Gas Group	Capacitance μF	Inductance μH	or	L/R Ratio $\mu H/Ohm$
IIC	43	0.7		140
IIB	1000	5.2		560
IIA	1000	10		1120

Instructions Specific to Hazardous Area Installations

The following instructions apply to equipment covered by certificate number Sira 00ATEX2062:

1. The equipment may be used with flammable gases and vapors with apparatus groups IIC, IIB, and IIA and with temperature classes T1, T2, T3, and T4.
2. The equipment is only certified for use in ambient temperatures in the range -40°C to +70°C and should not be used outside this range.
3. Installation shall be carried out in accordance with the applicable code of practice.
4. Repair of this equipment shall be carried out in accordance with the applicable code of practice.
5. Certification marking as detailed in drawing numbers 9150 074-801, 9150 074-802, and 9150 074-803.

ATEX DIRECTIVE (94/9/EC)

Rosemount Inc. complies with the ATEX Directive.

ORDINARY LOCATION CERTIFICATION FOR FACTORY MUTUAL

As standard, the transmitter has been examined and tested to determine that the design meets basic electrical, mechanical, and fire protection requirements by FM, a nationally recognized testing laboratory (NRTL) as accredited by the Federal Occupational Safety and Health Administration (OSHA).

CANADIAN REGISTRATION NUMBER (CRN)

The product design of the Cone Antenna has been accepted and registered for use in Canada.
CRN: 0F1015.9C

Rosemount 5600 Series

HAZARDOUS LOCATIONS CERTIFICATIONS

ATEX Approvals

5600 Series Level Transmitter

E1 Certificate Number: Sira 03ATEX 1294X

With Intrinsically Safe Outputs

ATEX Marking: Ⓢ II (2) (1) 1/2 GD

Safety Coding: EEx de [ib] [ia] IIC T6 (T_{amb} -40°C, +70°C)

With Non-IS Primary Output and IS Display Output

ATEX Marking: Ⓢ II (1) 1/2 GD

Safety Coding: EEx de [ia] IIC T6 (T_{amb} -40°C, +70°C)

With Non-IS Primary and/or Non-IS Secondary Outputs and without Display Panel Output

ATEX Marking: Ⓢ II 1/2 GD

Safety Coding: EEx de IIC T6 (T_{amb} -40°C, +70°C)

Max supply voltage: 55 Vdc

Passive analog output 4-20mA,

Label identification = HART passive.

Voltage compliance 7-30V:

$U_i < 30 \text{ V}$

$I_i < 200 \text{ mA}$

$P_i < 1.3 \text{ W}$

$C_i = 0 \text{ } \mu\text{F}$

$L_i = 0 \text{ mH}$

Active analog output 4-20mA,

Label identification = HART active.

Max load 300Ω:

$U_o < 23.1 \text{ V}$

$I_o < 125.7 \text{ mA}$

$P_o < 0.726 \text{ W}$

$C_{\text{ext}} < 0.14 \text{ } \mu\text{F}$

$L_{\text{ext}} < 2.2 \text{ mH}$

FOUNDATION Fieldbus,

Label identification = FOUNDATION fieldbus.

$U_i < 30 \text{ V}$

$I_i < 300 \text{ mA}$

$P_i < 1.3 \text{ W}$

$C_i = 0 \text{ } \mu\text{F}$

$L_i = 0 \text{ mH}$

2210 Display Unit

- E1** Certificate Number: Sira 00ATEX 2062
Without Temperature Inputs
ATEX Marking: Ⓢ II 2 G
Safety Coding: EEx ib IIC T4 (T_{amb} -40°C, +70°C)
With Temperature Inputs
ATEX Marking: Ⓢ II 2 (1) G
Safety Coding: EEx ib [ia] IIC T4, (T_{amb} -40°C, +70°C)

Factory Mutual (FM)

5600 Series Level Transmitter

- E5** Certificate Number: 4D5A9.AX
With Intrinsically safe outputs
(all versions except those listed below)
Explosion proof with IS outputs for HAZLOC
Class I, Division 1, Group A, B, C and D, T6
Max operating temperature +70°C
Dust ignition proof for use in Class II/III, Division 1,
Groups E, F, and G, T5.
Use conductors rated at least 85°C
Shall be installed in accordance with System control drawing
9150074-994.
With Non-IS Secondary Outputs (codes 1 and 3)
Explosion proof
Class I, Division 1, Group A, B, C and D, T6
Max operating temperature +70°C
Dust ignition proof for use in Class II/III, Division 1,
Groups E, F, and G, T5.
Use conductors rated at least 85°C

2210 Display Unit

- E5** Certificate: 3008356
All Versions
Intrinsic Safe for HAZLOC
Class I, Division 1, Group A, B, C and D T4
Max operating temperature +70°C
Shall be installed in accordance with System control drawing
9150074-997.

Canadian Standards Association (CSA)

5600 Series Level Transmitter

E6 Certificate Number: 2003.153280-1346169

With Non-IS Primary and/or Non-IS Secondary Outputs

Explosion proof Ex de IIC T6

Shall be installed in accordance with System control drawing 9150074-937.

Factory seal, conduit seal not required.

With IS Display Outputs, IS Primary and/or IS Secondary Outputs.

Explosion proof Ex de [ib/ia] IIC T6

Shall be installed in accordance with System control drawing 9150074-939.

Factory seal, conduit seal not required.

2210 Display Unit

E6 Certificate Number: 2003.153280-1346165

Without Temperature Inputs

Intrinsically safe EEx ib IIC T4, (T_{amb} -40°C, +70°C)

With Temperature Inputs

Intrinsically safe EEx ib [ia] IIC T4, (T_{amb} -40°C, +70°C)

Shall be installed in accordance with System control drawing 9150074-944.

ATEX APPROVAL DRAWINGS

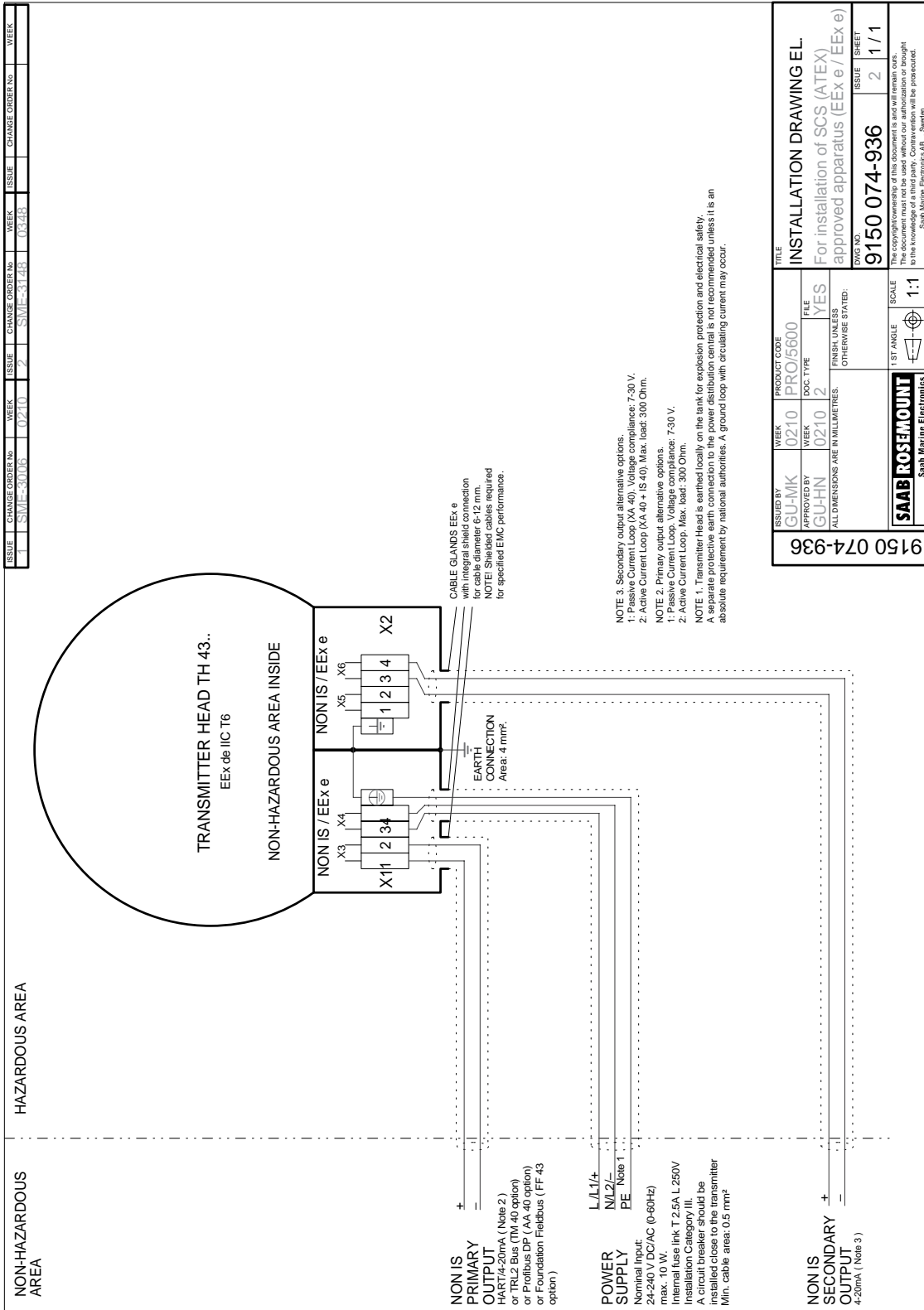

ISSUE	CHANGE ORDER No	WEEK	ISSUE	CHANGE ORDER No	WEEK	ISSUE	CHANGE ORDER No	WEEK
1	SME-3006	0210	2	SME-3148	0348			

ISSUED BY		PRODUCT CODE		TITLE	
GU-MK	0210	PRO/5600	FILE	INSTALLATION DRAWING EL.	
APPROVED BY		DOC. TYPE		For installation of SCS (ATEX) approved apparatus (EEx e / EEx e)	
GU-HN	0210	2	FINISH UNLESS OTHERWISE STATED:	DWG NO	ISSUE / SHEET
ALL DIMENSIONS ARE IN MILLIMETRES.				9150 074-936	2 / 11
SAAB ROSEMOUNT Saab Marine Electronics			1:1	The copyright ownership of this document is and will remain ours. This document is loaned to you for your use only. It is not to be distributed to the knowledge of a third party. Conservation will be prioritized. Saab Marine Electronics AB - Sweden	

5600/INSTALLATION DRAWINGS/9150 074-936.EPS

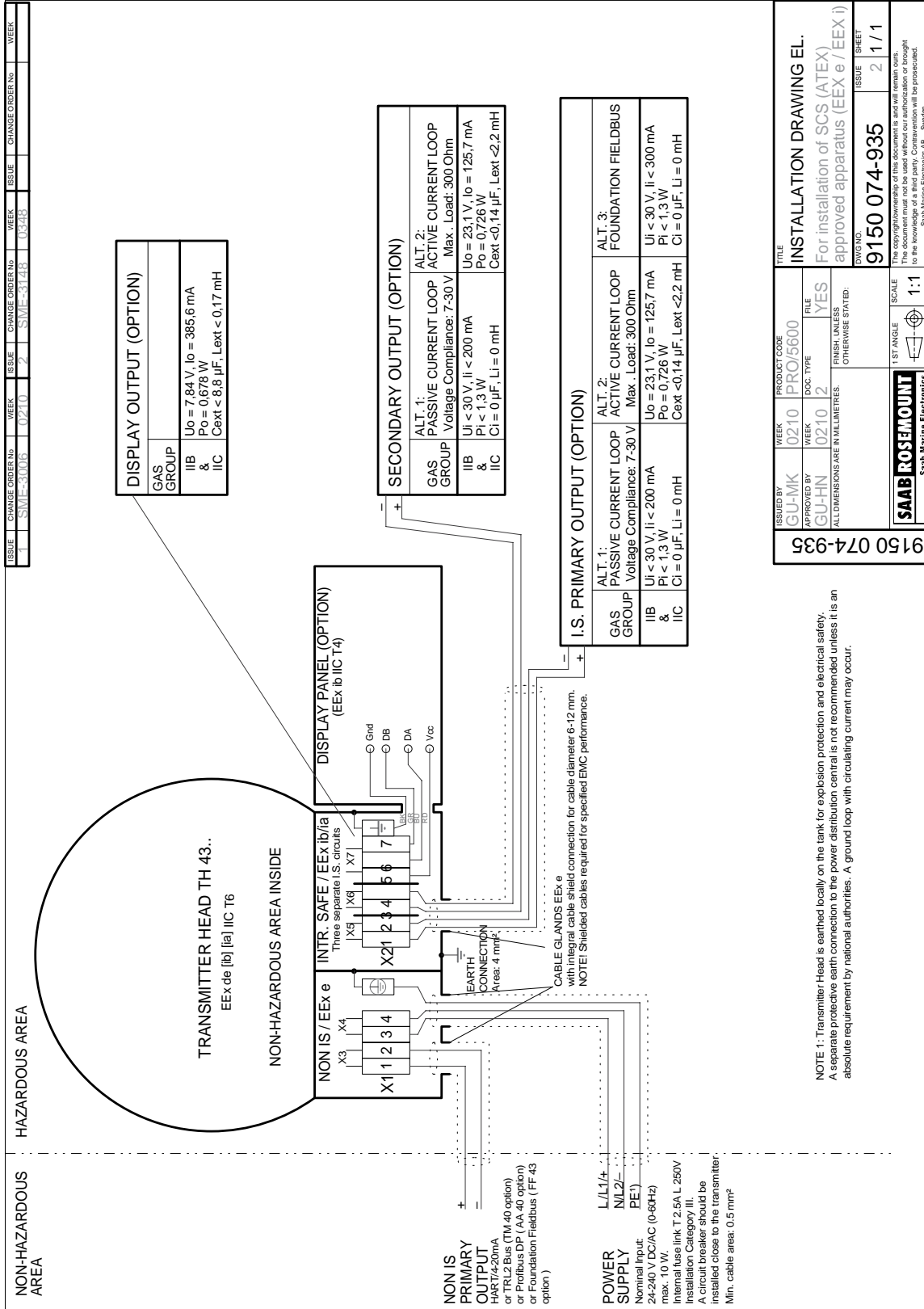

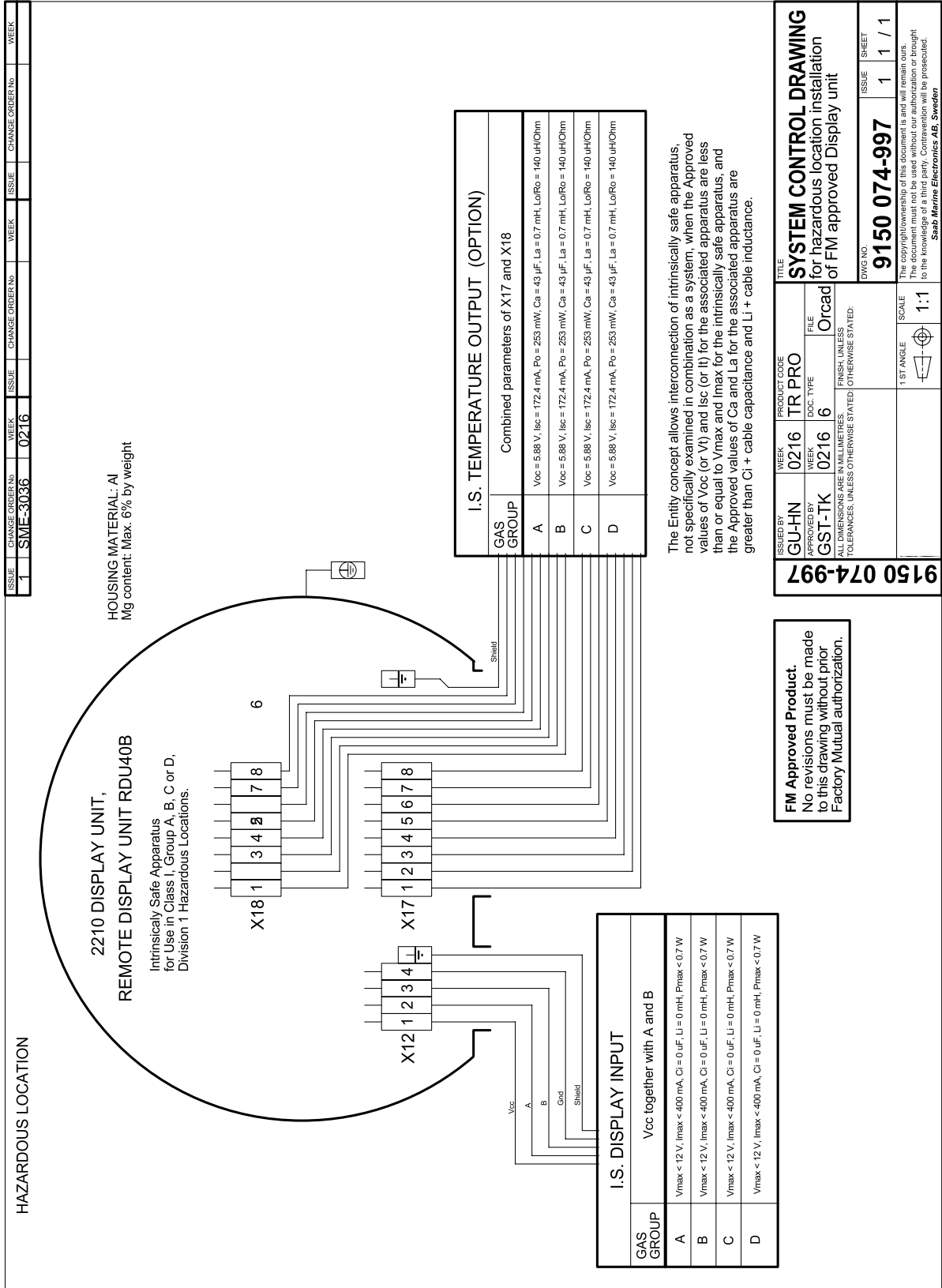

FM Approved Product.
No revisions must be made to this drawing without prior Factory Mutual authorization.

The Entity concept allows interconnection of intrinsically safe apparatus, not specifically examined in combination as a system, when the Approved values of Voc (or Vi) and Isc (or Ii) for the associated apparatus are less than or equal to Vmax and Imax for the intrinsically safe apparatus, and the Approved values of Ca and La for the associated apparatus are greater than Ci + cable capacitance and Li + cable inductance.

9150 074-997		9150 074-997	
ISSUED BY	WEEK	PROJECT CODE	FILE
GU-HN	0216	TR PRO	Orcad
APPROVED BY	WEEK	DOC. TYPE	FINISH UNLESS
GST-TK	0216	6	OTHERWISE STATED;
ALL DIMENSIONS ARE IN MILLIMETRES.		TOLERANCES, UNLESS OTHERWISE STATED:	
SCALE		1:1	
DWG NO		ISSUE	
9150 074-997		1 / 1	
The copyright/ownership of this document is and will remain ours. The document must not be used without our authorization or brought to the knowledge of a third party. Continuation will be prosecuted.			
Saab Marine Electronics AB, Sweden			

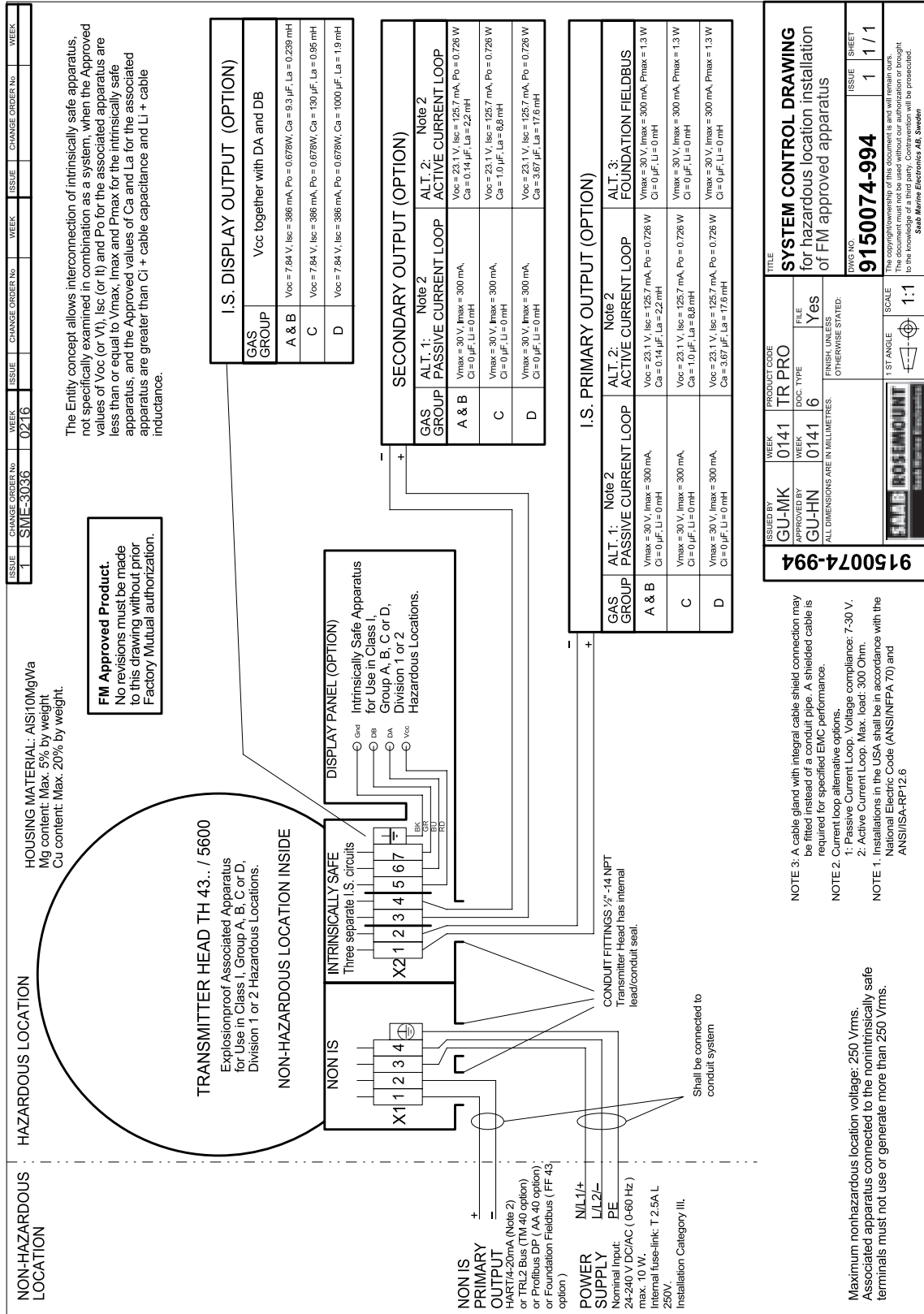

ISSUE	CHANGE ORDER NO.	WEEK	ISSUE	CHANGE ORDER NO.	WEEK	ISSUE	CHANGE ORDER NO.	WEEK
1	SME-3036	0216						

ISSUED BY: GUMK
APPROVED BY: GUHN

WEEK: 0141
WEEK: 0141

PRODUCT CODE: TR PRO
DOC. TYPE: 6

TITLE: SYSTEM CONTROL DRAWING for hazardous location installation of FM approved apparatus

DWG NO: 9150074-994

SCALE: 1:1

FINISH, UNLESS OTHERWISE STATED:

ALL DIMENSIONS ARE IN MILLIMETRES.

1 ST ANGLE

9150074-994

SAAB ROSEMOUNT

SHEET: 1 / 1

RoSEMOUNT
The copyright in this drawing is reserved by Saab Marine Electronics AB. This drawing may not be reproduced, stored in a retrieval system, or transmitted in any form or by any means, without the prior written permission of Saab Marine Electronics AB, Sweden.

CSA APPROVAL DRAWINGS

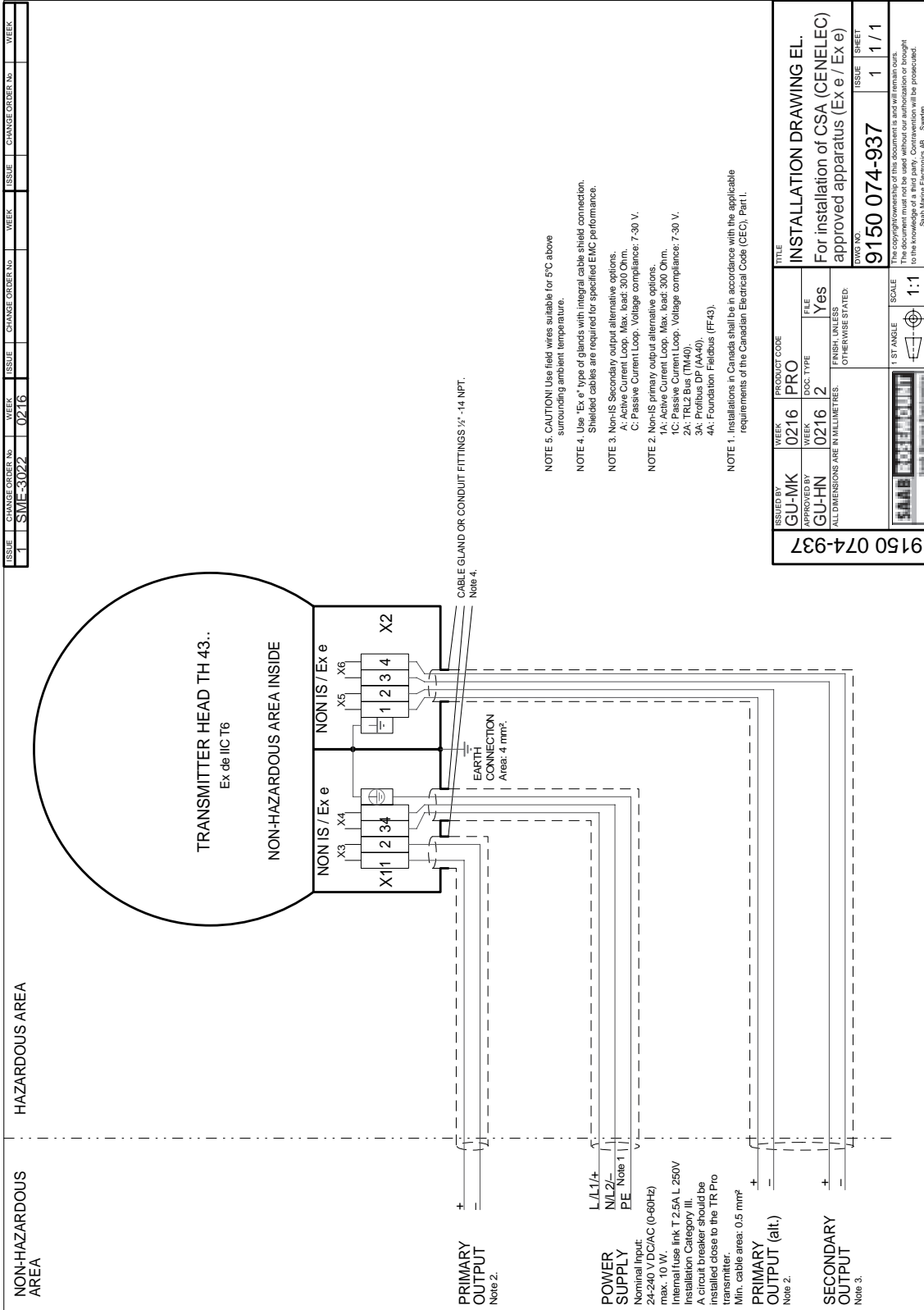

ISSUE	CHANGE ORDER NO.	WEEK	ISSUE	CHANGE ORDER NO.	WEEK	ISSUE	CHANGE ORDER NO.	WEEK
1	SME-3022	0216						

ISSUED BY		WEEK		PRODUCT CODE		TITLE	
GU-MK		0216		PRO		INSTALLATION DRAWING EL.	
APPROVED BY		WEEK		DOC. TYPE		FILE	
GU-HN		0216		2		Yes	
ALL DIMENSIONS ARE IN MILLIMETRES.				OTHERWISE STATED			
DWG. NO.		ISSUE		SHEET			
9150 074-937		1		1 / 1			
		SCALE		1:1		The copyright/ownership of this document is and will remain ours. The document must not be used without our authorization or brought to the knowledge of any third party without our consent. Saab Marine Electronics AB, Sweden	

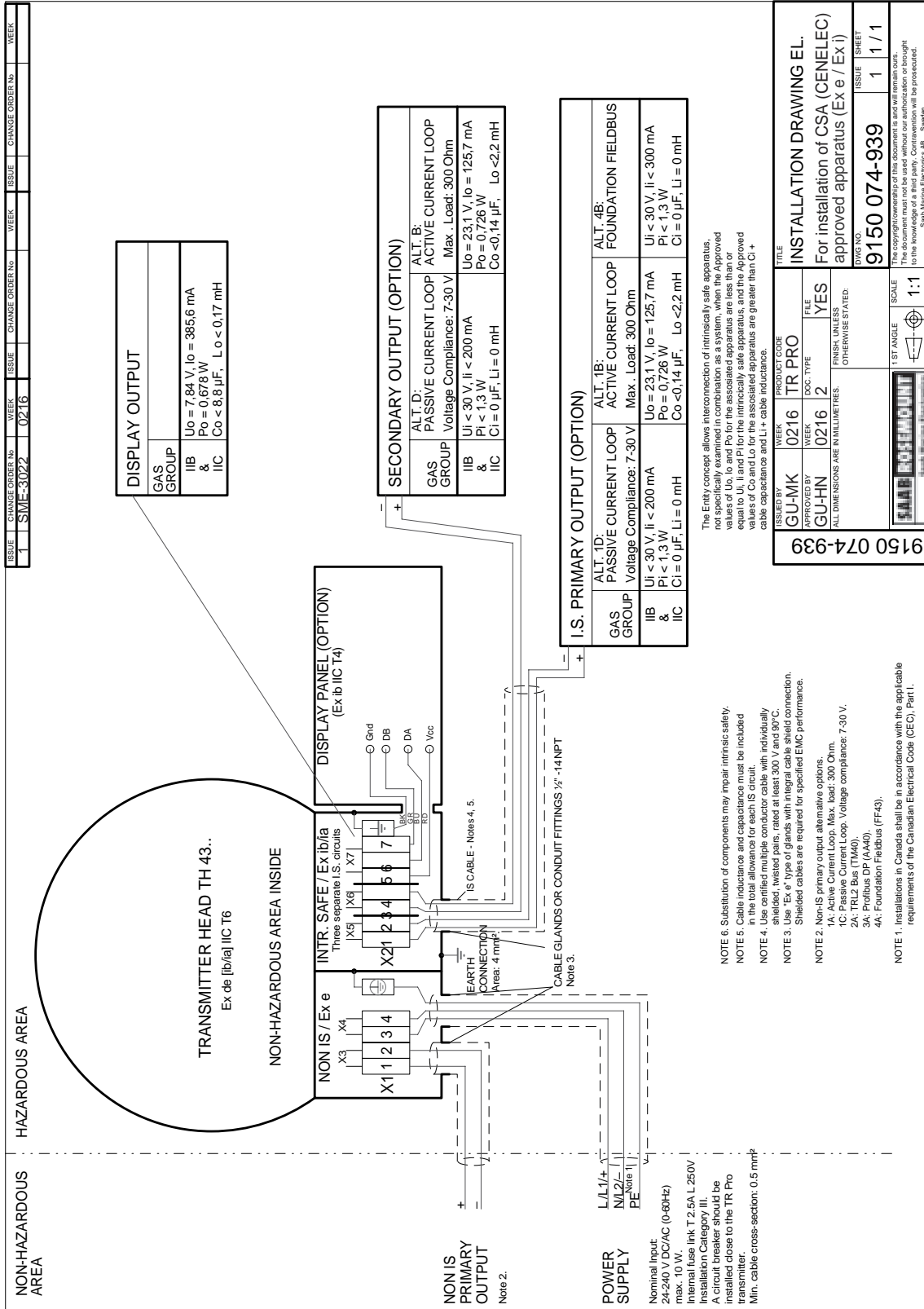

ISSUE	CHANGE ORDER NO.	WEEK	ISSUE	CHANGE ORDER NO.	WEEK	ISSUE	CHANGE ORDER NO.	WEEK
1	SME-3022	0216						

DESIGN NO.	9150 074-939	ISSUE	1	1	1
------------	--------------	-------	---	---	---

FILE	INSTALLATION DRAWING EL.
FOR installation of CSA (GENELEC) approved apparatus (Ex e / Ex i)	

ISSUED BY	WEEK	PROJ. CODE	FILE
GU-MK	0216	TR PRO	YES
APPROVED BY	WEEK	DOC. TYPE	FINISH, UNLESS OTHERWISE STATED.
GU-HN	0216	2	

SCALE	1:1
-------	-----

9150 074-939

Appendix C Level Transducer Block

Supported Units page C-7
Channel Assignments page C-1

Overview

This section contains information on the 5600 Transducer Block (TB). Descriptions of all Transducer Block parameters, errors, and diagnostics are listed. Also, the modes, alarm detection, status handling, application information, and troubleshooting are discussed.

Figure C-1. Transducer Block Diagram

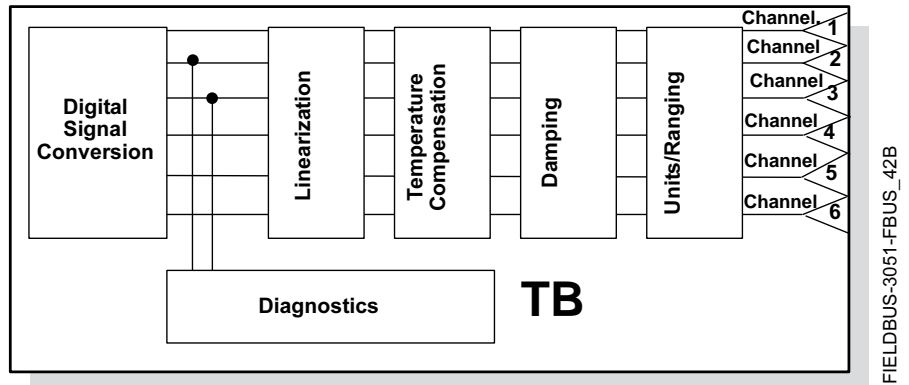

FOUNDATION Fieldbus

Definition

The transducer block contains the actual measurement data, including a level and distance reading. Channels 1–6 are assigned to these measurements (see Figure C-1). The transducer block includes information about sensor type, engineering units, and all parameters needed to configure the radar transmitter.

Channel Definitions

Each input has a channel assigned to it allowing the AI block to link to it. The channels for the Rosemount 5600 are the following:

Table C-1. Channel Assignments

AI-block	TB channel Value	Process variable
Level	1	CHANNEL_RADAR_LEVEL
Ullage	2	CHANNEL_RADAR_ULLAGE
Level Rate	3	CHANNEL_RADAR_LEVELRATE
Signal Strength	4	CHANNEL_RADAR_SIGNAL_STRENGTH
Volume	5	CHANNEL_RADAR_VOLUME
Average Temperature	6	CHANNEL_RADAR_AVG_TEMP

Rosemount 5600 Series

Parameters and Descriptions

Table C-2. Level Transducer Block Parameters and Descriptions

Parameter	Index Number	Description
ST_REV	1	The revision level of the static data associated with the function block. The revision value increments each time a static parameter value in the block is changed.
TAG_DESC	2	The user description of the intended application of the block.
STRATEGY	3	The strategy field can be used to identify grouping of blocks. This data is not checked or processed by the block.
ALERT_KEY	4	The identification number of the plant unit. This information may be used in the host for sorting alarms, etc.
MODE_BLK	5	The actual, target, permitted, and normal modes of the block. Target: The mode to "go to" Actual: The mode the "block is currently in" Permitted: Allowed modes that target may take on Normal: Most common mode for target
BLOCK_ERR	6	This parameter reflects the error status associated with the hardware or software components associated with a block. It is a bit string, so that multiple errors may be shown.
UPDATE_EVT	7	This alert is generated by any change to the static data.
BLOCK_ALM	8	The block alarm is used for all configuration, hardware, connection failure or system problems in the block. The cause of the alert is entered in the subcode field. The first alert to become active will set the Active status in the Status parameter. As soon as the Unreported status is cleared by the alert reporting task, another block alert may be reported without clearing the Active status, if the subcode has changed.
TRANSDUCER_DIRECTORY	9	Directory that specifies the number and starting indices of the transducers in the transducer block.
TRANSDUCER_TYPE	10	Identifies the transducer.
XD_ERROR	11	A transducer block alarm subcode.
COLLECTION_DIRECTORY	12	A directory that specifies the number, starting indices, and DD Item ID's of the data collections in each transducer within a transducer block.
RADAR_LEVEL_TYPE	13	See Table C-7 on page C-5
RADAR_LEVEL	14	Level Value
RADAR_LEVEL_RANGE	15	See Table C-14 on page C-7
RADAR_ULLAGE	16	Ullage value
RADAR_LEVELRATE	17	Level Rate value
RADAR_LEVELRATE_RANGE	18	Ref corresponding unit
RADAR_SIGNAL_STRENGTH	19	Signal strength valve
RADAR_SIGNAL_STRENGTH_RANGE	20	See Table C-16 on page C-7
RADAR_VOLUME	21	Volume valve
RADAR_VOLUME_RANGE	22	See Table C-17 on page C-7
RADAR_AVG_TEMP	23	Average Temperature
RADAR_TEMP_1	24	Spot temperature 1
RADAR_TEMP_RANGE	25	See Table C-15 on page C-7
RADAR_TEMP_2	26	Spot temperature 2
RADAR_TEMP_3	27	Spot temperature 3
RADAR_TEMP_4	28	Spot temperature 4
RADAR_TEMP_5	29	Spot temperature 5
RADAR_TEMP_6	30	Spot temperature 6
ANTENNA_TYPE	31	Antenna Type, see Table C-3 on page C-4

Parameter	Index Number	Description
ANTENNA_TCL	32	TCL (Tank connection Length)
ANTENNA_PIPE_DIAM	33	Pipe Diameter, see document 00809-0100-4024
GEOM_DIST_OFFSET	34	Distance offset, see document 00809-0100-4024
GEOM_TANK_HEIGHT	35	Tank Height, see document 00809-0100-4024
GEOM_MIN_LEVEL_OFFSET	36	Minimum distance offset, see document 00809-0100-4024
GEOM_HOLD_OFF	37	Hold Off, see document 00809-0100-4024
GEOM_CAL_DISTANCE	38	Calibration Distance
GEOM_TANK_TYPE	39	Tank Type, see Table C-7 on page C-5, see document 00809-0100-4024
GEOM_TANK_BOTTOM_TYPE	40	Tank Bottom Type, see Table C-8 on page C-5, see document 00809-0100-4024
ENV_ENVIRONMENT	41	
ENV_PRESENTATION	42	
ENV_DEVICE_MODE	43	Switch to sensor bus
ENV_TANK_TYPE_OPTIONS	44	Tank Type Options, see Table C-7 on page C-5
ENV_DIELECTR_CONST	45	Dielectrical Constant
DIAGN_DEV_ERR	46	
DIAGN_VERSION	47	Transmitter SW version
DIAGN_REVISION	48	P1451 revision (NOTE: This version must be checked by the Output Board in order to verify that the software is compatible.)
DIAGN_DEVICE_ID	49	Device ID for the transmitter
TEMP_NUM_SENSORS	50	Num Temp Spots
TEMP_SENSOR_TYPE	51	Sensor Type
TEMP_INSERT_DIST	52	Insertion distance
TEMP_EXCL_AVG_CALC	53	Exclude from Avg. Temp. calculation
TEMP_POS_1	54	Position sensor 1
TEMP_POS_2	55	Position sensor 2
TEMP_POS_3	56	Position sensor 3
TEMP_POS_4	57	Position sensor 4
TEMP_POS_5	58	Position sensor 5
TEMP_POS_6	59	Position sensor 6
STATS_ATTEMPTS	60	Ref 3
STATS_FAILURES	61	Ref 3
STATS_TIMEOUTS	62	Ref 3

FOUNDATION Fieldbus

Rosemount 5600 Series

FOUNDATION Fieldbus

Table C-3. Antenna Type

VALUE	ANTENNA_TYPE
0	User Defined
1	Cone 4, PTFE
2	Cone 4, QUARTZ
3	Reserved
4	Reserved
5	Cone 6, PTFE
6	Cone 6, QUARTZ
7	Reserved
8	Reserved
9	Cone 8, PTFE
10	Cone 8, QUARTZ
11	Reserved
12	Reserved
13	Pipe, PTFE
14	Pipe, QUARTZ
15	Rod
16	Parabolic
17	Process Seal 4 PTFE
18	Process Seal 4 Ceramic
19	Process Seal 6 PTFE
20	Process Seal 6 Ceramic
21	Cone 3, PTFE
22	Cone 3, QUARTZ
23	Pipe ITG 6, PTFE
24	Pipe ITG 8, PTFE
25	Pipe ITG 10, PTFE
26	Pipe ITG 12, PTFE

Table C-4. Device Mode

Value	ENV_DEVICE_MODE
0	FF bus
1	Sensorbus
2	Restart device
3	Set to factory default database

Table C-5. Environment

Bit Number	Value of ENV_ENVIRONMENT	Description
0	0	-
1	0x00000001	Reserved
2	0x00000002	Rapid Changes
3	0x00000004	Reserved
4	0x00000008	Turbulent Surface
5	0x00000010	Foam
6	0x00000020	Solid Product

Table C-6. Presentation

Bit Number	Value of Env_Presentation	Description
0	0	-
1	0x00000001	Reserved
2	0x00000002	Reserved
3	0x00000004	Reserved
4	0x00000008	Bottom echo visible
5	0x00000010	Tank contains double bounce
6	0x00000020	Slow Search
7	0x00000040	Double Surfaces
8	0x00000080	Select lower surface
9	0x00000100	-
10	0x00000200	Show negative levels as zero
11	0x00000400	Reserved
12	0x00000800	Reserved
13	0x00001000	Reserved
14	0x00002000	Reserved
15	0x00004000	Invalid level is NOT set if tank is empty
16	0x00008000	If set and if bit 12 not set, Invalid level is NOT set if tank is full
17	0x00010000	-
18	0x00020000	Reserved
19	0x00040000	Reserved

FOUNDATION Fieldbus

Table C-7. Tank Type

Value	GEOM_TANK_TYPE
0	Unknown
1	Vertical Cylinder
3	Horizontal Cylinder
4	Spherical
5	Cubical

Table C-8. Tank Bottom Type

Value	GEOM_TANK_BOTTOM_TYPE
0	Unknown
1	Flat
2	Dome
3	Cone
4	Flat Inclined

Table C-9. Dielectrical Constant

Value	ENV_DIELECTR_CONST
0	Unknown
1	Range (1-2, 5)
2	Range (2, 4-5)
3	Range (4-10)
4	Range (>10)

Rosemount 5600 Series

Diagnostics Device Errors

In addition to the BLOCK_ERR and XD_ERROR parameters, more detailed information on the measurement status can be obtained via DIAGN_DEV_ERR. Table C-10 on page C-6 lists the potential errors and the possible corrective actions for the given values. The corrective actions are in order of increasing system level compromises. The first step should always be to reset the transmitter and then if the error persists, try to the steps in Table C-10. Start with the first corrective action and then try the second.

Table C-10. Device Errors
Diagnostics

Bit Number	Value of DIAGN_DEV_ERR	Description	Corrective Actions
0	0	No alarm active	See page 6-1
1	0x00000001	Reserved	See page 6-1
2	0x00000002	FF card to transmitter comm fault	See page 6-1
3	0x00000004	Level Measurement Failure	See page 6-1
4	0x00000008	Temperature Measurement Failure	See page 6-1
5	0x00000010	Volume Measurement Failure	See page 6-1
6	0x00000020	Invalid ATP	See page 6-1
7	0x00000040	No surface echo	See page 6-1
8	0x00000080	Tank signal clip warning	See page 6-1
9	0x00000100	Empty Tank	See page 6-1
10	0x00000200	Full Tank	See page 6-1
11	0x00000400	Conf. Reg. Pwd. Enabled	See page 6-1
12	0x00000800	DB Error	See page 6-1
13	0x00001000	Microwave unit error	See page 6-1
14	0x00002000	Display error	See page 6-1
15	0x00004000	Analog out error	See page 6-1
16	0x00008000	Other HW error	See page 6-1
17	0x00010000	Configuration error	See page 6-1
18	0x00020000	SW error	See page 6-1
19	0x00040000	DB Warning	See page 6-1
20	0x00080000	Microwave unit Warning	See page 6-1
21	0x00100000	Display Warning	See page 6-1
22	0x00200000	Analog out Warning	See page 6-1
23	0x00400000	Other HW Warning	See page 6-1
24	0x00800000	Configuration Warning	See page 6-1
25	0x01000000	SW Warning	See page 6-1

Table C-11. Temperature sensor
type

Value	TEMP_CONV_METHOD Description
0	User defined linearization table
1	User defined formula
2	DIN PT 100
3	CU90

Table C-12. Exclude from avg. temp. calculation

Bit Number	Value of TEMP_EXCL_AVG_CALC	Description
0	0	-
1	0x00000001	Reserved
2	0x00000002	Exclude nbr. 1
3	0x00000004	Exclude nbr. 2
4	0x00000008	Exclude nbr. 3
5	0x00000010	Exclude nbr. 4
6	0x00000020	Exclude nbr. 5
7	0x00000040	Exclude nbr. 6

SUPPORTED UNITS

Unit codes

Table C-13. Length

Value	Display	Description
1010	m	meter
1018	ft	feet
1019	in	inch
1013	mm	millimeter

Table C-14. Level Rate

Value	Display	Description
1067	ft/s	feet per second
1061	m/s	meter per second
1063	m/h	meter per hour

Table C-15. Temperature

Value	Display	Description
1000	K	Kelvin
1001	°C	Degree Celsius
1002	°F	Degree Fahrenheit

Table C-16. Signal Strength

Value	Display	Description
1243	mV	Millivolt

Table C-17. Volume

Value	Display	Description
1034	m ³	Cubic meter
1048	Gallon	US gallon
1051	bbl	barrel
1043	ft ³	Cubic feet

Methods

Refer to “Methods and Manual Operation” on page 8-4.

Rosemount 5600 Series

Appendix D Resource Block

Overview	page D-1
Parameters and Descriptions	page D-2

OVERVIEW

This section contains information on the Rosemount 5600 Series Radar Level Transmitter Resource Block. Descriptions of all Resource Block Parameters, errors, and diagnostics are included. Also the modes, alarm detection, status handling, and troubleshooting are discussed.

Definition

The resource block defines the physical resources of the device. The resource block also handles functionality that is common across multiple blocks. The block has no linkable inputs or outputs.

FOUNDATION Fieldbus

Rosemount 5600 Series

PARAMETERS AND DESCRIPTIONS

The table below lists all of the configurable parameters of the Resource Block, including the descriptions and index numbers for each.

Parameter	Index Number	Description
ACK_OPTION	38	Selection of whether alarms associated with the function block will be automatically acknowledged.
ADVISE_ACTIVE	82	Enumerated list of advisory conditions within a device.
ADVISE_ALM	83	Alarm indicating advisory alarms. These conditions do not have a direct impact on the process or device integrity.
ADVISE_ENABLE	80	Enabled ADVISE_ALM alarm conditions. Corresponds bit for bit to the ADVISE_ACTIVE. A bit on means that the corresponding alarm condition is enabled and will be detected. A bit off means the corresponding alarm condition is disabled and will not be detected.
ADVISE_MASK	81	Mask of ADVISE_ALM. Corresponds bit of bit to ADVISE_ACTIVE. A bit on means that the condition is masked out from alarming.
ADVISE_PRI	79	Designates the alarming priority of the ADVISE_ALM
ALARM_SUM	37	The current alert status, unacknowledged states, unreported states, and disabled states of the alarms associated with the function block.
ALERT_KEY	04	The identification number of the plant unit.
BLOCK_ALM	36	The block alarm is used for all configuration, hardware, connection failure or system problems in the block. The cause of the alert is entered in the subcode field. The first alert to become active will set the Active status in the Status parameter. As soon as the Unreported status is cleared by the alert reporting task, another block alert may be reported without clearing the Active status, if the subcode has changed.
BLOCK_ERR	06	This parameter reflects the error status associated with the hardware or software components associated with a block. It is a bit string, so that multiple errors may be shown.
CLR_FSAFE	30	Writing a Clear to this parameter will clear the device FAIL_SAFE if the field condition has cleared.
CONFIRM_TIME	33	The time the resource will wait for confirmation of receipt of a report before trying again. Retry will not happen when CONFIRM_TIME=0.
CYCLE_SEL	20	Used to select the block execution method for this resource. The Rosemount 5600 supports the following: Scheduled: Blocks are only executed based on the function block schedule. Block Execution: A block may be executed by linking to another blocks completion.
CYCLE_TYPE	19	Identifies the block execution methods available for this resource.
DD_RESOURCE	09	String identifying the tag of the resource which contains the Device Description for this resource.
DD_REV	13	Revision of the DD associated with the resource - used by an interface device to locate the DD file for the resource.
DEFINE_WRITE_LOCK	60	Allows the operator to select how WRITE_LOCK behaves. The initial value is "lock everything". If the value is set to "lock only physical device" then the resource and transducer blocks of the device will be locked but changes to function blocks will be allowed.
DETAILED_STATUS	55	Indicates the state of the transmitter. See Resource Block detailed status codes.
DEV_REV	12	Manufacturer revision number associated with the resource - used by an interface device to locate the DD file for the resource.
DEV_STRING	43	This is used to load new licensing into the device. The value can be written but will always read back with a value of 0.
DEV_TYPE	11	Manufacturer's model number associated with the resource - used by interface devices to locate the DD file for the resource.
DIAG_OPTION	46	Indicates which diagnostics licensing options are enabled.
DISTRIBUTOR	42	Reserved for use as distributor ID. No Foundation enumerations defined at this time.
DOWNLOAD_MODE	67	Gives access to the boot block code for over-the-wire downloads. 0 = Uninitialized 1 = Run mode 2 = Download mode

Parameter	Index Number	Description
FAIL_SAFE	28	Condition set by loss of communication to an output block, fault promoted to an output block or physical contact. When FAIL_SAFE condition is set, then output function blocks will perform their FAIL_SAFE actions.
FAILED_ACTIVE	72	Enumerated list of failure conditions within a device.
FAILED_ALM	73	Alarm indicating a failure within a device which makes the device non-operational.
FAILED_ENABLE	70	Enabled FAILED_ALM alarm conditions. Corresponds bit for bit to the FAILED_ACTIVE. A bit on means that the corresponding alarm condition is enabled and will be detected. A bit off means the corresponding alarm condition is disabled and will not be detected.
FAILED_MASK	71	Mask of FAILED_ALM. Corresponds bit of bit to FAILED_ACTIVE. A bit on means that the condition is masked out from alarming.
FAILED_PRI	69	Designates the alarming priority of the FAILED_ALM.
FB_OPTION	45	Indicates which function block licensing options are enabled.
FEATURES	17	Used to show supported resource block options. See Error! Reference source not found. The supported features are: SOFT_WRITE_LOCK_SUPPORT, HARD_WRITE_LOCK_SUPPORT, REPORTS, and UNICODE
FEATURES_SEL	18	Used to select resource block options.
FINAL_ASSY_NUM	54	The same final assembly number placed on the neck label.
FREE_SPACE	24	Percent of memory available for further configuration. Zero in a preconfigured device.
FREE_TIME	25	Percent of the block processing time that is free to process additional blocks.
GRANT_DENY	14	Options for controlling access of host computers and local control panels to operating, tuning, and alarm parameters of the block. Not used by device.
HARD_TYPES	15	The types of hardware available as channel numbers.
HARDWARE_REV	52	Hardware revision of the hardware that has the resource block in it.
ITK_VER	41	Major revision number of the inter operability test case used in certifying this device as interoperable. The format and range are controlled by the Fieldbus Foundation.
LIM_NOTIFY	32	Maximum number of unconfirmed alert notify messages allowed.
MAINT_ACTIVE	77	Enumerated list of maintenance conditions within a device.
MAINT_ALM	78	Alarm indicating the device needs maintenance soon. If the condition is ignored, the device will eventually fail.
MAINT_ENABLE	75	Enabled MAINT_ALM alarm conditions. Corresponds bit for bit to the MAINT_ACTIVE. A bit on means that the corresponding alarm condition is enabled and will be detected. A bit off means the corresponding alarm condition is disabled and will not be detected.
MAINT_MASK	76	Mask of MAINT_ALM. Corresponds bit of bit to MAINT_ACTIVE. A bit on means that the condition is masked out from alarming.
MAINT_PRI	74	Designates the alarming priority of the MAINT_ALM
MANUFAC_ID	10	Manufacturer identification number – used by an interface device to locate the DD file for the resource.
MAX_NOTIFY	31	Maximum number of unconfirmed notify messages possible.
MEMORY_SIZE	22	Available configuration memory in the empty resource. To be checked before attempting a download.
MESSAGE_DATE	57	Date associated with the MESSAGE_TEXT parameter.
MESSAGE_TEXT	58	Used to indicate changes made by the user to the device's installation, configuration, or calibration.
MIN_CYCLE_T	21	Time duration of the shortest cycle interval of which the resource is capable.
MISC_OPTION	47	Indicates which miscellaneous licensing options are enabled.
MODE_BLK	05	The actual, target, permitted, and normal modes of the block: Target: The mode to “go to” Actual: The mode the “block is currently in” Permitted: Allowed modes that target may take on Normal: Most common mode for actual
NV_CYCLE_T	23	Minimum time interval specified by the manufacturer for writing copies of NV parameters to non-volatile memory. Zero means it will never be automatically copied. At the end of NV_CYCLE_T, only those parameters which have changed need to be updated in NVRAM.
OUTPUT_BOARD_SN	53	Output board serial number.

Rosemount 5600 Series

Parameter	Index Number	Description
RB_SFTWR_REV_ALL	51	The string will contains the following fields: Major rev: 1-3 characters, decimal number 0-255 Minor rev: 1-3 characters, decimal number 0-255 Build rev: 1-5 characters, decimal number 0-255 Time of build: 8 characters, xx:xx:xx, military time Day of week of build: 3 characters, Sun, Mon,... Month of build: 3 characters, Jan, Feb. Day of month of build: 1-2 characters, decimal number 1-31 Year of build: 4 characters, decimal Builder: 7 characters, login name of builder
RB_SFTWR_REV_BUILD	50	Build of software that the resource block was created with.
RB_SFTWR_REV_MAJOR	48	Major revision of software that the resource block was created with.
RB_SFTWR_REV_MINOR	49	Minor revision of software that the resource block was created with.
RECOMMENDED_ACTION	68	Enumerated list of recommended actions displayed with a device alert.
RESTART	16	Allows a manual restart to be initiated. Several degrees of restart are possible. They are the following: 1 Run – nominal state when not restarting 2 Restart resource – not used 3 Restart with defaults – set parameters to default values. See START_WITH_DEFAULTS below for which parameters are set. 4 Restart processor – does a warm start of CPU.
RS_STATE	07	State of the function block application state machine.
SAVE_CONFIG_BLOCKS	62	Number of EEPROM blocks that have been modified since last burn. This value will count down to zero when the configuration is saved.
SAVE_CONFIG_NOW	61	Allows the user to optionally save all non-volatile information immediately.
SECURITY_IO	65	Status of security switch.
SELF_TEST	59	Instructs resource block to perform self-test. Tests are device specific.
SET_FSAFE	29	Allows the FAIL_SAFE condition to be manually initiated by selecting Set.
SHED_RCAS	26	Time duration at which to give up on computer writes to function block RCas locations. Shed from RCas shall never happen when SHED_ROUT = 0
SHED_ROUT	27	Time duration at which to give up on computer writes to function block ROut locations. Shed from ROut shall never happen when SHED_ROUT = 0
SIMULATE_IO	64	Status of simulate switch.
SIMULATE_STATE	66	The state of the simulate switch: 0 = Uninitialized 1 = Switch off, simulation not allowed 2 = Switch on, simulation not allowed (need to cycle jumper/switch) 3 = Switch on, simulation allowed
ST_REV	01	The revision level of the static data associated with the function block.
START_WITH_DEFAULTS	63	0 = Uninitialized 1 = do not power-up with NV defaults 2 = power-up with default node address 3 = power-up with default pd_tag and node address 4 = power-up with default data for the entire communications stack (no application data)
STRATEGY	03	The strategy field can be used to identify grouping of blocks.
SUMMARY_STATUS	56	An enumerated value of repair analysis.
TAG_DESC	02	The user description of the intended application of the block.
TEST_RW	08	Read/write test parameter - used only for conformance testing.
UPDATE_EVT	35	This alert is generated by any change to the static data.
WRITE_ALM	40	This alert is generated if the write lock parameter is cleared.
WRITE_LOCK	34	If set, no writes from anywhere are allowed, except to clear WRITE_LOCK. Block inputs will continue to be updated.
WRITE_PRI	39	Priority of the alarm generated by clearing the write lock.
XD_OPTION	44	Indicates which transducer block licensing options are enabled.

Appendix E Register Transducer Block

Register Access Transducer Block Parameters page E-1

OVERVIEW

The Register Transducer Block allows access to Database registers and Input registers of the 5600 Series transmitters. This makes it possible to read a selected set of register directly by accessing the memory location.

The Register Transducer Block is only available with advanced service.

CAUTION

Since this Register Transducer Block allows access to most registers in the transmitter, which includes the registers set by the Methods and Configuration screens, in the Level Transducer Block (see Appendix C: Level Transducer Block) it should be handled with care and ONLY to be changed by trained and certified service personnel, or as guided by Emerson Process Management, Rosemount Division support personnel.

REGISTER ACCESS TRANSDUCER BLOCK PARAMETERS

Parameter	Index Number	Description
ST_REV	1	The revision level of the static data associated with the function block. The revision value increments each time a static parameter value in the block is changed.
TAG_DESC	2	The user description of the intended application of the block.
STRATEGY	3	The strategy field can be used to identify grouping of blocks. This data is not checked or processed by the block.
ALERT_KEY	4	The identification number of the plant unit. This information may be used in the host for sorting alarms, etc.
MODE_BLK	5	The actual, target, permitted, and normal modes of the block. Target: The mode to "go to" Actual: The mode the "block is currently in" Permitted: Allowed modes that target may take on Normal: Most common mode for target
BLOCK_ERR	6	This parameter reflects the error status associated with the hardware or software components associated with a block. It is a bit string, so that multiple errors may be shown.
UPDATE_EVT	7	This alert is generated by any change to the static data.

Rosemount 5600 Series

Parameter	Index Number	Description
BLOCK_ALM	8	The block alarm is used for all configuration, hardware, connection failure or system problems in the block. The cause of the alert is entered in the subcode field. The first alert to become active will set the Active status in the Status parameter. As soon as the Unreported status is cleared by the alert reporting task, another block alert may be reported without clearing the Active status, if the subcode has changed.
TRANSDUCER_DIRECTORY	9	Directory that specifies the number and starting indices of the transducers in the transducer block.
TRANSDUCER_TYPE	10	Identifies the transducer. 100 = Standard pressure with calibration
XD_ERROR	11	A transducer block alarm subcode.
COLLECTION_DIRECTORY	12	A directory that specifies the number, starting indices, and DD Item ID's of the data collections in each transducer within a transducer block.
INP_SEARCH_START_NBR	13	Search start number for input registers
DB_SEARCH_START_NBR	14	Search start number for holding registers
INP_REG_1_NAME	16	Name of the register
INP_REG_1_FLOAT	17	If the register contains a float value it shall be displayed here
INP_REG_1_INT_DEC	18	If the register contains a DWORD value and <i>dec</i> is chosen, it shall be displayed here
INP_REG_2_NAME	20	
INP_REG_2_FLOAT	21	
INP_REG_2_INT_DEC	22	
INP_REG_3_NAME	24	
INP_REG_3_FLOAT	25	
INP_REG_3_INT_DEC	26	
INP_REG_4_NAME	28	
INP_REG_4_FLOAT	29	
INP_REG_4_INT_DEC	30	
INP_REG_5_NAME	32	
INP_REG_5_FLOAT	33	
INP_REG_5_INT_DEC	34	
INP_REG_6_NAME	36	
INP_REG_6_FLOAT	37	
INP_REG_6_INT_DEC	38	
INP_REG_7_NAME	40	
INP_REG_7_FLOAT	41	
INP_REG_7_INT_DEC	42	
INP_REG_8_NAME	44	
INP_REG_8_FLOAT	45	
INP_REG_8_INT_DEC	46	
INP_REG_9_NAME	48	
INP_REG_9_FLOAT	49	
INP_REG_9_INT_DEC	50	
INP_REG_10_NAME	52	
INP_REG_10_FLOAT	53	
INP_REG_10_INT_DEC	54	
DB_REG_1_NAME	57	Name of the register
DB_REG_1_FLOAT	58	If the register contains a float value it shall be displayed here
DB_REG_1_INT_DEC	59	If the register contains a DWORD value and <i>dec</i> is chosen, it shall be displayed here
DB_REG_2_NAME	61	

Parameter	Index Number	Description
DB_REG_2_FLOAT	62	
DB_REG_2_INT_DEC	63	
DB_REG_3_NAME	65	
DB_REG_3_FLOAT	66	
DB_REG_3_INT_DEC	67	
DB_REG_4_NAME	69	
DB_REG_4_FLOAT	70	
DB_REG_4_INT_DEC	71	
DB_REG_4_NAME	73	
DB_REG_4_FLOAT	74	
DB_REG_4_INT_DEC	75	
DB_REG_5_NAME	77	
DB_REG_5_FLOAT	78	
DB_REG_5_INT_DEC	79	
DB_REG_6_NAME	81	
DB_REG_6_FLOAT	82	
DB_REG_6_INT_DEC	83	
DB_REG_7_NAME	85	
DB_REG_7_FLOAT	86	
DB_REG_7_INT_DEC	87	
DB_REG_8_NAME	89	
DB_REG_8_FLOAT	90	
DB_REG_8_INT_DEC	91	
DB_REG_9_NAME	93	
DB_REG_9_FLOAT	94	
DB_REG_9_INT_DEC	95	
DB_REG_10_NAME	97	
DB_REG_10_FLOAT	98	
DB_REG_10_INT_DEC	99	
INP_SEARCH_CHOICE	101	Search for register by name or by number.
INP_SEARCH_START_GROUP	102	Available when searching by name
INP_SEARCH_START_NAME	103	Available when searching by name
DB_SEARCH_CHOICE	104	Search for register by name or by number
DB_SEARCH_START_GROUP	105	Available when searching by name
DB_SEARCH_START_NAME	106	Available when searching by name

FOUNDATION Fieldbus

Rosemount 5600 Series

Reference Manual
00809-0100-4025, Rev BA
September 2005

Index

A

Activate Lease Square Filter . . . 4-18
Active Adaptive Filter 4-18
Active Jump Filter 4-18
Address
 Temporary Node 6-3
Adjusting the LCD Contrast
 Rosemount 2210 Display Unit
 Adjusting the LCD Contrast
 7-3
Advanced Configuration 4-6
 Analog Output 4-7
 Bottom Echo Handling . . . 4-14
 Calibration Distance 4-6
 Distance Offset 4-6
 Disturbance Echo Handling 4-11
 Empty Tank Handling . . . 4-15
 Filtering 4-18
 Full Tank Handling 4-15
 Minimum Level Offset 4-6
 Process Conditions 4-9
 Foam 4-9, 6-10
 Rapid Level Changes 4-9,
 6-10
 Solid Products . . 4-9, 6-10
 Turbulent Surface 4-9, 6-10
 Show Negative Values as Zero
 4-6
 Surface Tracking 4-16
 Temperature Measurement 4-9
 Number of Sensors . . 4-9
 Sensor Mounting Level 1-6
 4-9
 Volume Calculation 4-10
Analog Input (AI) Block . . . 6-2, 8-9
 BLOCK_ERR 8-9
 Troubleshooting 8-9
Analog Input (AI) Function Block 8-9
Analog Output 4-7
Antenna 4-3
 Hold Off Distance 4-3
 Pipe Inner Diameter 4-3
 Tank Connection Length . . 4-3
Approvals B-6

B

Block Errors 8-9

Block Instantiation 8-6
BLOCK_ERR
 AI Block 8-9
 Resource Block 8-8
Bottom Echo Handling 4-14
 Bottom Echo Visible 4-14
 Invalid Level Alarm is not Set if
 Tank is Empty 4-14
Bottom Echo Visible 4-14

C

Calibration Distance 4-6, 8-4
Channel 6-10, C-1
Channel Definitions
 Level Transducer Block . . . C-1
Close Distance Window 4-16
Commission
 HART Communicator 5-7
Cone Antenna
 Extended
 Mounting 2-37
 PTFE Sealing
 Mounting 2-14, 2-17
Configuration 4-1
 Advanced 4-6
 Analog Input (AI) Function Block
 OUT_SCALE 6-11
 XD_SCALE 6-11
 Basic
 Tank Geometry 4-5
 Calibration Distance 8-4
 Channel 6-10
 Delta V 6-4
 Direct 6-11
 Indirect 6-11
 L_TYPE 6-11
 Direct 6-11
 Indirect 6-11
 Sensor Bus Port 6-16
Connections and Hardware
 HART Communicator 5-9
Custom Setup
 Rosemount 2210 7-10
Customized Noise Threshold Table
4-13

D

Delta V
 Configure the Parameters . . 6-4
 Fieldbus Device Properties 6-4
Device Revision 6-2
Device Tag 6-3
Diagnostics Device Errors
 Level Transducer Block . . . C-6
Diagram
 Function Blocks 6-1
Direct 6-11
Display Setup
 Rosemount 2210 7-7
Display Unit
 Menu Tree 7-2
Distance Filter Factor 4-18
Distance Offset 4-6
Disturbance Echo Handling . . . 4-11
 Customized Noise Threshold table
 4-13
 General Amplitude Threshold 4-12
 Registration of False Echoes 4-13
Double Bounce Offset 4-17
Double Bounce Possible 4-17
Double Surface 4-16

E

Echo Timeout 4-16
Electrical
 Connection 6-16
 Intrinsically Wiring . . 3-10
 Model Code 3-9
 Non-Intrinsically Wiring 3-9
 Installation
 Power Supply 3-8
 Power Connections 3-9
Empty Tank Detection Area . . . 4-15
Empty Tank Handling 4-15
 Empty Tank Detection Area 4-15
Entering a Password
 Rosemount 2210 7-4
Entering Numerical Values
 Rosemount 2210 7-6
Extended
 Cone Antenna
 Mounting 2-37

Rosemount 5600 Series

- F**
- FCC Requirements 1-6
 - Field Upgrades 8-2, 8-7
 - Labeling 8-2
 - Filtering 4-18
 - Activate Jump Filter 4-18
 - Activate Least Square Filter 4-18
 - Active Adaptive Filter 4-18
 - Close Distance Window 4-16
 - Distance Filter Factor 4-18
 - Echo Timeout 4-16
 - Foam 4-9, 6-10
 - Free Space
 - Requirements 2-4
 - Full Tank Handling 4-15
 - Invalid Level Alarm is Not Set if Tank is Empty 4-15
 - Function Block
 - Diagram 6-1
- G**
- General Amplitude Threshold 4-12
 - Grounding 3-10
 - Shielded Wire 3-10
 - Guided Setup
 - Rosemount 2210 7-9
- H**
- HART Communicator
 - Commission 5-7
 - Connections and Hardware 5-9
 - Level Configuration Example 5-10
 - Setting the Loop to Manual 5-9
 - HART Communicator Menu Tree 5-8
 - HART Fast Keys 5-9
 - Hazardous Locations
 - Certifications
 - FM B-6
 - Hazardous Locations Installations
 - See Approvals B-6
 - Hold Off Distance 4-3
- I**
- Ideal Tank
 - Volume Calculation 4-10
 - Indirect 6-11
 - Installation
 - Requirements
 - Free Space 2-4
 - Nozzle 2-3
 - Rosemount 2210 7-8
 - Tools 2-2
 - Intrinsically Wiring 3-10
 - Invalid Level Alarm is Not Set if Tank is Empty 4-15
 - Invalid Level Alarm is not Set if Tank is Empty 4-14
- K**
- K2 ADE
 - Connecting 6-17
 - Keys
 - HART 5-9
 - Rosemount 2210 7-4
- L**
- L_TYPE 6-11
 - Label 8-2
 - Language
 - Rosemount 2210 7-8
 - Level above Min. Distance Possible 4-16
 - Level Configuration Example
 - HART Communicator 5-10
 - Level Transducer Block
 - Channel Definitions C-1
 - Diagnostics Device Errors C-6
 - Parameters and Descriptions C-2
 - Supported Units C-7
 - Unit Codes C-7
- M**
- Manual Operation 8-4
 - Master Reset Method
 - Resource Block 8-4
 - Measurement Principle 1-4
 - Menu Tree
 - 2210 Display Unit 7-2
 - HART Communicator 5-8
 - Methods 8-4
 - Minimum Level Offset 4-6
 - Model Code 3-9
 - Mounting
 - Cone Antenna
 - Extended 2-37
 - PTFE Sealing 2-14, 2-17
 - Still-pipe/Bridle 2-25
 - Parabolic Antenna 2-31
 - Process Seal Antenna 2-22
 - Rod Antenna
 - Threaded Version 2-11
- N**
- Node Address 6-3
 - Non-Intrinsically Wiring 3-9
 - Number of Sensors 4-9
- O**
- Operation 6-2
 - Block Instantiation 8-6
- P**
- Calibration Distance Configuration 8-4
 - Master Reset Method
 - Resource Block 8-4
 - Rosemount 2210 7-3
 - Service Method 8-4
 - Write Protection
 - Resource Block 8-4
 - WRITE_LOCK Parameter 8-5
 - OUT_SCALE 6-11
 - L_TYPE
 - Direct 6-11
 - Indirect 6-11
 - Output
 - Analog 4-7
- P**
- Parabolic Antenna
 - Mounting 2-31
 - Parameter
 - BLOCK_ERR 8-8, 8-9
 - CHANNEL 6-10
 - L_TYPE 6-11
 - Level Transducer Block C-2
 - OUT_SCALE 6-11
 - Register Transducer Block E-1
 - Resource Block D-2
 - XD_SCALE 6-11
 - Password
 - Rosemount 2210 7-8
 - PC Configuration Software Radar Master 5-2
 - Pipe Inner Diameter 4-3
 - Power Connections 3-9
 - Power Supply 3-8
 - Presentation of Measured Data
 - Rosemount 2210 7-5
 - Process Conditions 4-9
 - Foam 4-9, 6-10
 - Number of Sensors 4-9
 - Rapid Level Changes 4-9, 6-10
 - Sensor Mounting Level 1-6, 4-9
 - Solid Products 4-9, 6-10
 - Turbulent Surface 4-9, 6-10
 - Process Seal Antenna
 - Mounting 2-22
 - Product Certifications
 - See Approvals B-6
 - PTFE Sealing
 - Mounting 2-14, 2-17
- R**
- Radar Master 5-2
 - Rapid Level Changes 4-9, 6-10
 - Register Transducer Block
 - Parameters E-1
 - Registration of False Echoes 4-13

Resource Block 8-8, D-1
 Block Errors 8-8
 Detailed Status 8-8
 Master Reset Method 8-4
 Parameters D-2
 BLOCK_ERR 8-8
 Summary Status 8-8
 Write Protection 8-4

Rod Antenna
 Threaded Version 2-11

Rosemount 2210 7-3

Rosemount 2210 Display Unit . . 7-2
 Display Setup 7-7
 Language 7-8
 Password 7-8
 Units 7-8
 User Defined View . . . 7-8

Entering a Password 7-4
 Entering Numerical Values . 7-6
 Installing the Transmitter . . 7-8
 Custom Setup 7-10
 Guided Setup 7-9

Menu Tree 7-2

Operation 7-3

Presentation of Measured Data
 7-5

Selecting Between Different Alternatives 7-5

Service 8-2

Softkeys 7-4

Viewing Level Data 7-6
 Single Value 7-6
 Standard View 7-7
 Temperature View . . . 7-7
 User Defined 7-6
 View Menu 7-6

Rosemount 5600
 Rosemount 2210
 Custom Setup 7-10
 Guided Setup 7-9
 Installation 7-8

S

Safety Messages 1-1, 2-1

Selecting Between Different Alternatives
 Rosemount 2210 7-5

Sensor Bus Mode
 Switching 6-18

Sensor Bus Port
 Configuration 6-16

Sensor Mounting Level 1-6 . . . 4-9

Service
 Rosemount 2210 Display Unit 8-2
 Spare Parts 1-9
 Support 1-9

Service Method

Operation 8-4

Setting the Loop to Manual
 HART Communicator 5-9

Show Negative Values as Zero . 4-6

Signal Wires
 Grounding 3-10

Single Value
 Rosemount 2210 7-6

Slow Search 4-16
 Speed 4-16

Solid Products 4-9, 6-10

Specific FCC Requirements . . . 1-6

Standard View
 Rosemount 2210 Display Unit 7-7

Still-pipe/Bridle
 Mounting 2-25

Strapping Table
 Volume Calculation 4-10

Supported Units 6-11

Surface Tracking 4-16
 Double Bounce Offset . . . 4-17
 Double Bounce Possible . . 4-17
 Double Surface 4-16
 Level above Min. Distance Possible 4-16
 Slow Search 4-16
 Slow Search Speed 4-16
 Upper Product DC 4-16

Symptom
 Troubleshooting Table . . . 8-2

T

Tag
 Device 6-3

Tank Bottom Type 4-5

Tank Connection Length 4-3

Tank Geometry 4-5
 Tank Bottom Type 4-5
 Tank Height 4-5
 Tank Type 4-5

Tank Height 4-5

Tank Type 4-5

Temperature Measurement . . . 4-9

Temperature View
 Rosemount 2210 7-7

Threaded Version
 Rod Antenna 2-11

Transmitter Functions 6-1

Troubleshooting
 Analog Input (AI) Block . . . 8-9
 Field Upgrades 8-7
 Reference Table 8-1
 Resource Block 8-8
 Table 8-2

Turbulent Surface 4-9, 6-10

U

Unit Codes
 Level Transducer Block . . . C-7

Units
 Rosemount 2210 7-8

Upper Product DC 4-16

User Defined
 Rosemount 2210 7-6

User Defined View 7-8

V

View Menu
 Rosemount 2210 7-6

Viewing Level Data
 Rosemount 2210 7-6

Volume Calculation 4-10
 Ideal Tank 4-10
 Strapping Table 4-10

W

Wiring
 Grounding 3-10
 Intrinsically 3-10
 Non-Intrinsically 3-9
 Power Connections 3-9

Write Protection
 Resource Block 8-4

WRITE_LOCK Parameter 8-5

X

XD_SCALE 6-11

L_TYPE
 Direct 6-11
 Indirect 6-11

Rosemount 5600 Series

Reference Manual
00809-0100-4024, Rev BA
March 2004

Emerson Process Management

Rosemount Inc.

8200 Market Boulevard
Chanhassen, MN 55317 USA
T (U.S.) 1-800-999-9307
T (International) (952) 906-8888
F (952) 949-7001

www.rosemount.com



Emerson Process Management

Heath Place
Bognor Regis
West Sussex PO22 9SH
England
Tel 44 (1243) 863 121
Fax 44 (1243) 867 5541

Emerson Process Management

Singapore Pte Ltd.
1 Pandan Crescent
Singapore 128461
Tel (65) 777-8211
Fax (65) 777-0947



EMERSON
Process Management