

TECH NOTE 1

## Do you think your loop is calibrated correctly? Think again!

**Example 1: UNDETECTED LONG STANDING FIELD CALIBRATION ERROR**

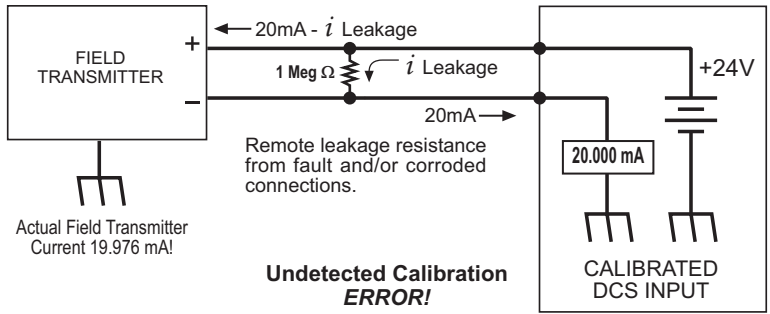

**Example 2: UNDETECTED CALIBRATION ERROR USING OTHER CALIBRATORS**

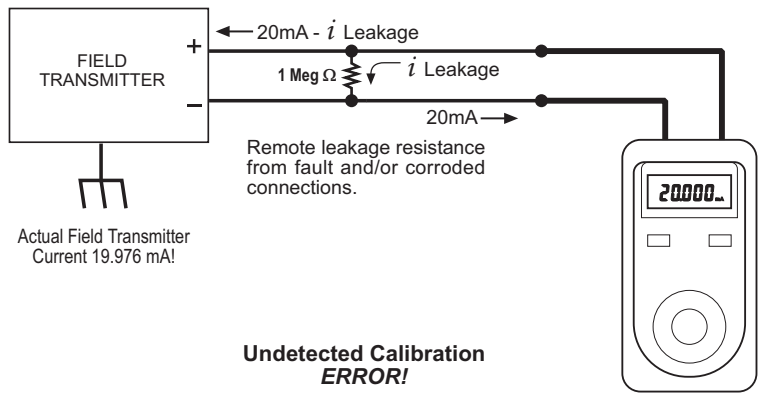

**Solution: CALIBRATION ERROR DETECTED USING THE MODEL 532**

**Using the Model 532  
in power measure mode,  
using loop diagnostic.**

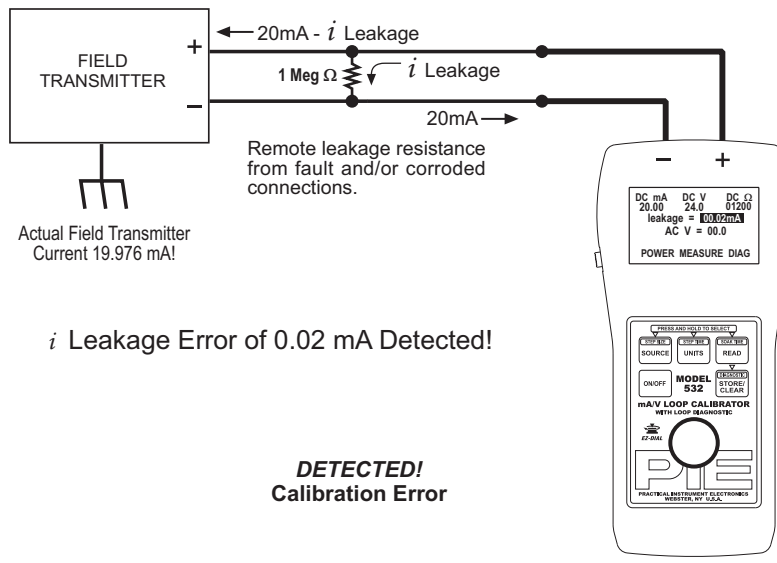

Patent Pending