

Rosemount 5300 Series

High Performance Guided Wave Radar



Designed To Make The Difference

ROSEMOUNT[®]



EMERSON[™]
Process Management

Innovative Design. Real Results.

The Rosemount 5300 Series is the next generation of Guided Wave Radar (GWR) from Emerson, the industry leader in level instrumentation. By drawing on over 30 years experience in the radar business, we have designed the 5300 to perform reliably in your most demanding applications. We leveraged the modular design, state-of-the-art electronics and robust housing from the 5400 non-contacting radar and the reliable probes from the 3300 GWR. The result is a proven, high performance radar that delivers real benefits from day one.

Direct Switch Technology (DST) Function for Improved Uptime

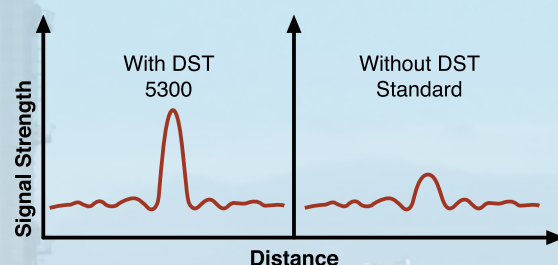
Our unique electronic DST Function provides a signal that is two to five times stronger than other GWR transmitters, increasing measurement reliability and capability. The improved signal to noise ratio means enhanced ability to handle disturbing factors, longer measuring ranges and lower dielectrics, even with a single lead probe. Now you can manage more applications reliably and avoid unplanned downtime caused by interrupted process monitoring.



Probe End Projection for Improved Measurement Capability

Probe end projection allows for measurements on very low dielectric constant products over long ranges. The method is based on the fact that microwaves propagate slower through product than through air. By using the product dielectric constant and the probe end echo, the surface position is calculated when the surface echo is unavailable. This substantially improves measurement capability.

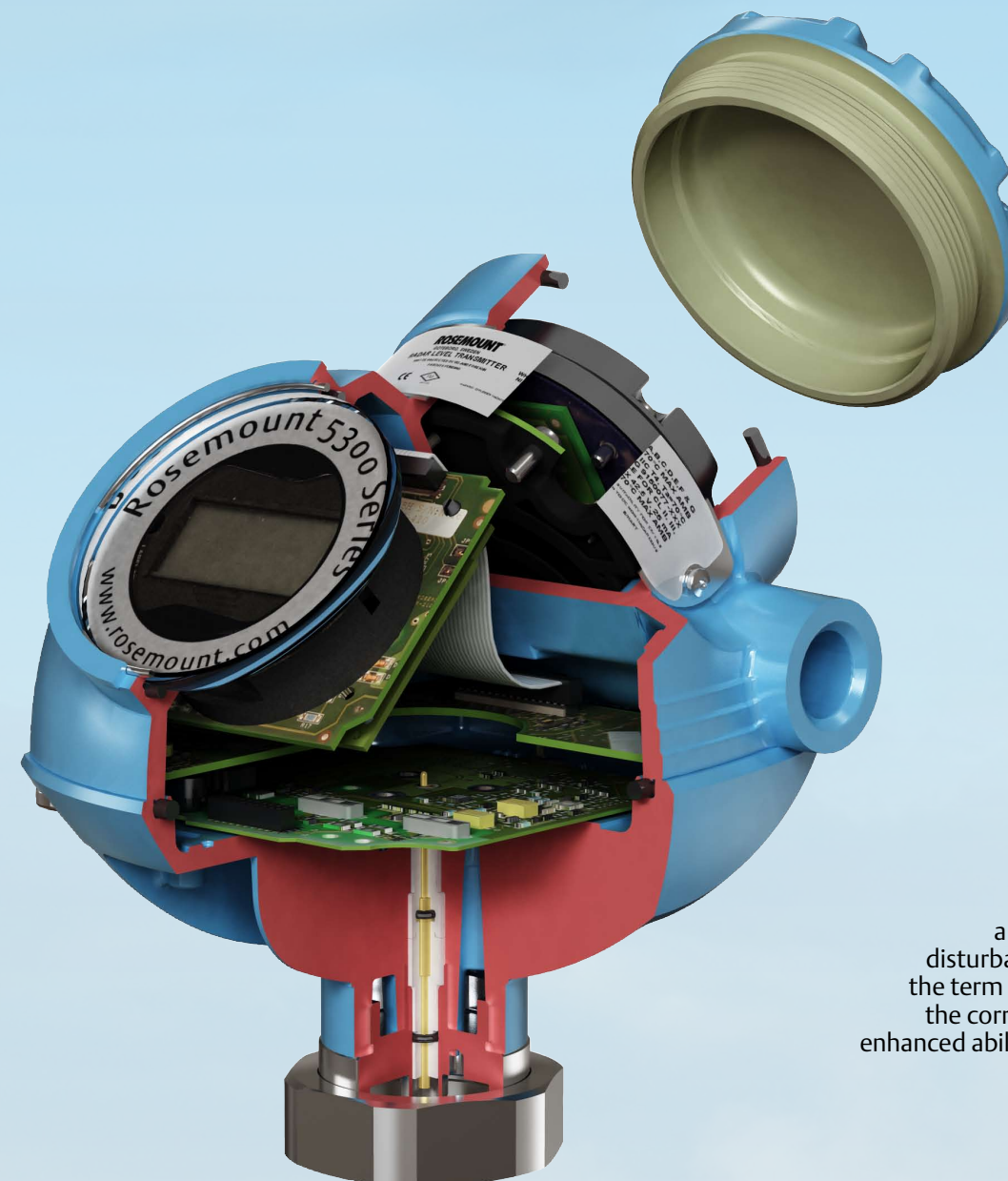
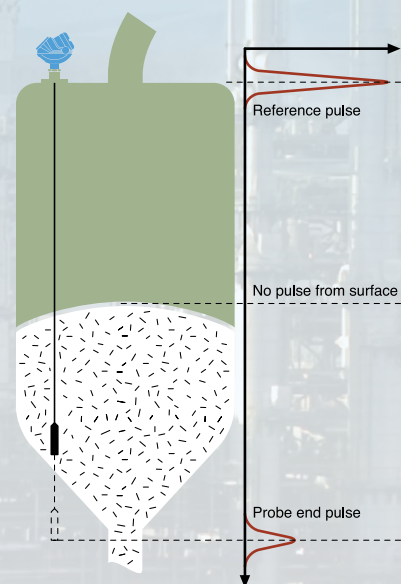

Smart Galvanic Interface for Increased Safety

The innovative ground plane configuration between the electronics, microwave components and housing results in a more stable microwave performance and minimizes unwanted disturbances. This improves the EMI performance and provides a more robust, safe measurement with minimized effects from outside disturbances.

EchoLogics for Reliable Overflow Detection

A key characteristic of a reliable radar transmitter is to always detect a full vessel situation even when several disturbance echoes are present. EchoLogics is the term we use for the capability to determine the correct level. The Rosemount 5300 has an enhanced ability to keep track of the surface at high levels, minimizing the risk of overfills.

Robust and Modular Design for Reduced Cost and Increased Safety

Electronics and cable connections are located in separate compartments, providing safer handling and improved moisture protection. The head can be removed without opening the tank and there is no matching between head and probes, protecting personnel and reducing maintenance cost.

High Accuracy for Improved Product Quality

Our patented crystal controlled timing circuit provides +/- 3mm reference accuracy. This results in better consistency and improved product quality.

MultiVariable™ Output Reduces Cost

The 5300 simultaneously measures level and interface on a 2-wire platform. This results in fewer process penetrations and reduced installation and wiring cost.

More Applications. Optimized.

The Rosemount 5300 series is suitable for all types of processing industries including oil & gas production, refining, petrochemical, chemical, power, and water & waste treatment. The Rosemount 5300 offers radar level measurement benefits for a wide range of applications in these industries. Its probe guided radar signal combined with innovative engineering makes the 5300 virtually unaffected by process conditions and it has almost no installation restrictions.



Combine Level And Interface Measurement

One 5300 transmitter will measure both the upper surface and the lower product interface in tanks with two products such as separators, settling tanks etc. This reduces the number of tank penetrations required. Use the 5300 with a single lead probe for reliable measurement of interface in crude oil and other liquids that create build-up.

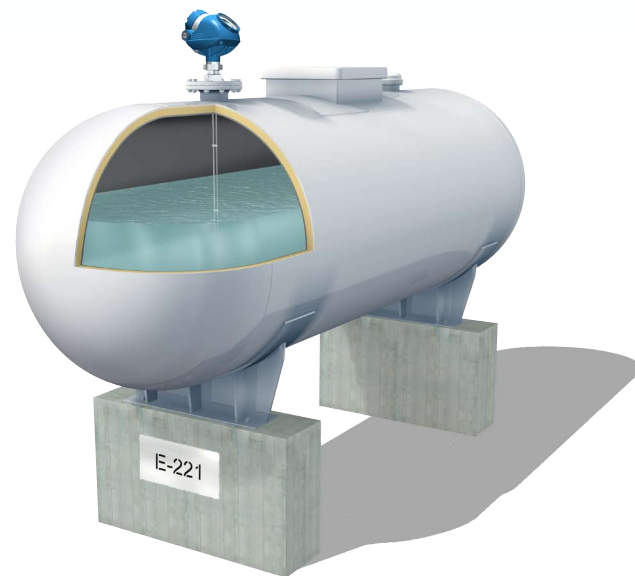

Improved Performance In Liquefied Gases

Being virtually maintenance-free and unaffected by turbulence and vapor, the Rosemount 5300 is perfect for liquid gas applications. The transmitter head can be serviced without breaching the tank atmosphere. Long measuring ranges enable operation in larger NGL, LPG and ammonia tanks.

Underground Benefits

Probes that are unaffected by high and narrow openings or nearby objects are available. This makes the 5300 the best choice for underground tanks, where the installation area is usually limited.

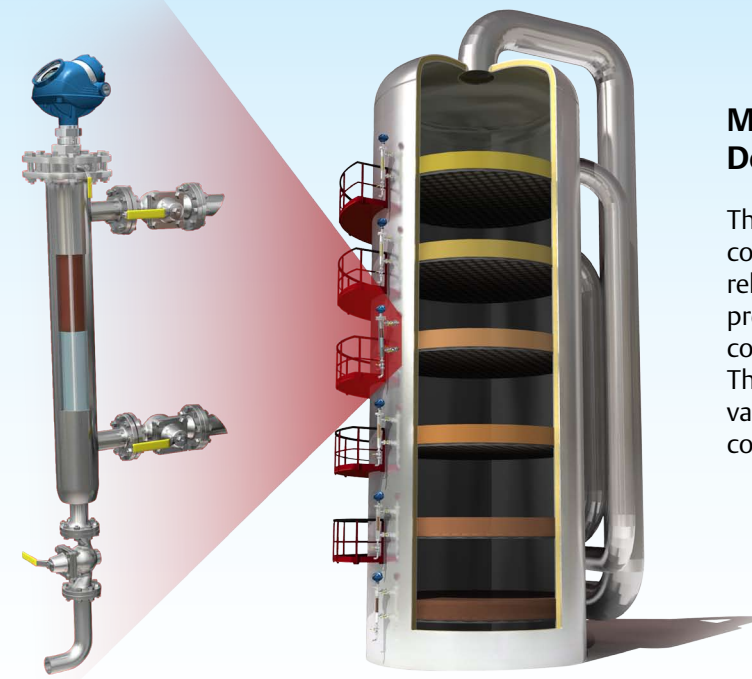
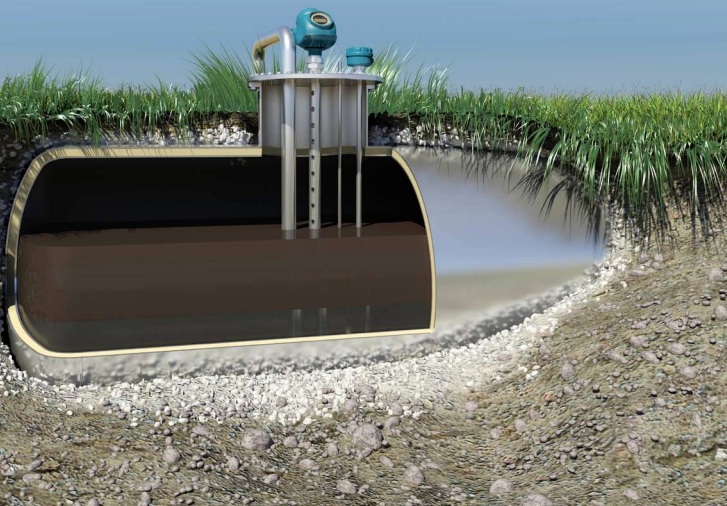

Minimize Risk In The Most Demanding Environments

The guided wave radar technology in the 5300 contains multiple layers of protection that enable reliable performance in high temperature and pressure tanks and bridges, on refinery distillation columns, and power feed-water tanks, etc. The measurement is not affected by density variations, low reflectivity media or the mechanical configuration of the bridge and the product inlet.

Solid Performance

Rosemount 5303 has a flexible single lead probe that measures solids with dielectric constants as low as 1.4. The measuring range is up to 160 ft. (50 m), and the transmitter has robust EMI performance. Special probes for high physical weight loads are available. Solids applications with the 5300 include powders and granules, plastics such as PVC, cement, fly ash, corn etc.



Measure In Vessels With Turbulence, Vapor And Mechanical Structures

The Rosemount 5300 delivers uninterrupted level data where others fail. With Direct Switch Technology, the reflection back from the surface is two to five times stronger compared with other guided wave radars. The result is a superior ability to handle disturbing objects, probe coating, vapor and turbulence.

Made to Last

Rosemount 5300 high temperature and high pressure (HTHP) probes are designed to prevent leakage and perform reliably when exposed to extreme process conditions for extended periods of time. The 5300 also offers probes in materials to handle harsh environments.

Wide Range of Probes

The 5300 offers high application flexibility with a wide range of probe styles including Coaxial, Twin and Single. Different materials and options for standard or extreme pressure and temperatures are available. All probes are delivered with a customer-specified length, but most can be cut to fit on site, if necessary.

Meeting The HTHP Challenge

The design of the 5300 probe provides multiple layers of protection. The seal includes a temperature and pressure barrier in a flexible assembly to handle forces induced by probe movement and temperature variations. A second brazed hermetic, gas-tight seal provides another layer of protection, and the entire assembly is welded into a stainless steel sleeve for total robustness.

The brazed hermetic, gas-tight ceramic seal is isolated from the process so temperature shocks, variations and outside forces on the probe will not affect the integrity of the seal.

A flexible probe load and locking system compensates for stress from thermal expansion and lateral and vertical forces. It also protects and fastens the ceramics.

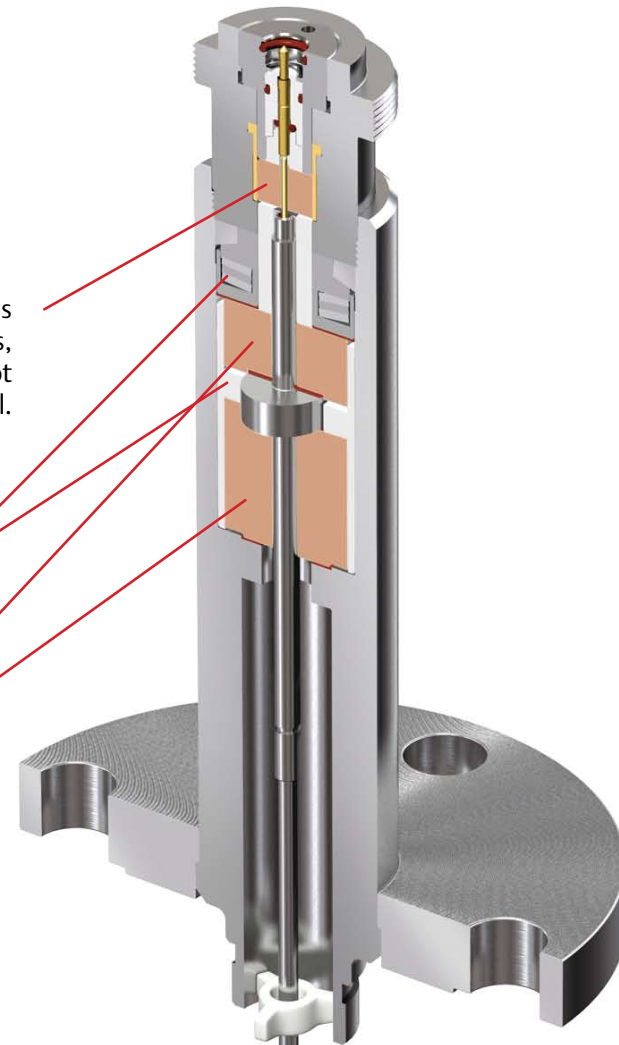

The ceramic insulators and graphite gaskets on the temperature and pressure seal provide a robust thermal and mechanical barrier as well as offering chemical resistance.

Corrosive Environments

Selecting materials for corrosive environments is critical to keeping your operation running at peak performance. In addition to SST there are Hastelloy, Monel and PTFE-covered SST material options available for the 5300. This allows for the installation of the 5300 in even more applications for the oil and gas, power, refining, chemical, and petrochemical industries.

Coaxial

- The optimal solution when there are disturbing objects close to the probe, high turbulence, liquid, or vapor spray on the probe and to avoid foam (the coax acts as a stilling well).
- For clean liquids only.
- Manages dielectric constants as low as 1.2.



Twin Lead

- Handles more viscous media than the coaxial probe. Avoid sticky media where there is risk of product bridging between probes.
- Handles disturbing objects close to the probe better than single probes. Avoid contact with metallic objects.



Single Lead

The most tolerant against coating and deposits. However, compared to other probe types, it is more affected by disturbing objects close to the probe.

Rigid

The rigid single lead probes are the best solutions for bypass installations.



Flexible

The flexible single lead probes are the best choice for solids, granulates and powders.



Easy Plant Integration

Installs Anywhere

Moving to a better level of transmitter couldn't be easier. The 5300 Series offers either FOUNDATION™ fieldbus or the analog 4-20mA with superimposed digital HART as output. This ensures easy installation into your new or existing control system.

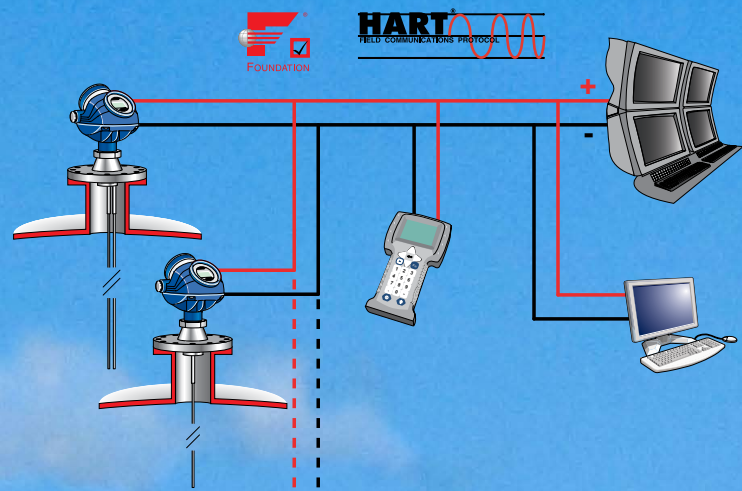

Predictive Maintenance. Efficient Control.

The 5300 utilizes advanced diagnostics with actionable information through PlantWeb® alerts. The alerts can be displayed for the operator and will describe the problem and recommended actions. With precise, actionable diagnostic capabilities the 5300 reduces your plant's downtime by enabling predictive maintenance and easier troubleshooting. The 5300 also powers PlantWeb through its innovative transmitter design and MultiVariable measurements.



The 5300 is loaded with 11 FOUNDATION fieldbus function blocks including AI-blocks for all process variables, which enable more efficient control of your process. Supervise your process in real-time by monitoring the radar signal strength with the built-in signal characterizer block to detect foam or probe contamination.

Simple Configuration and Service

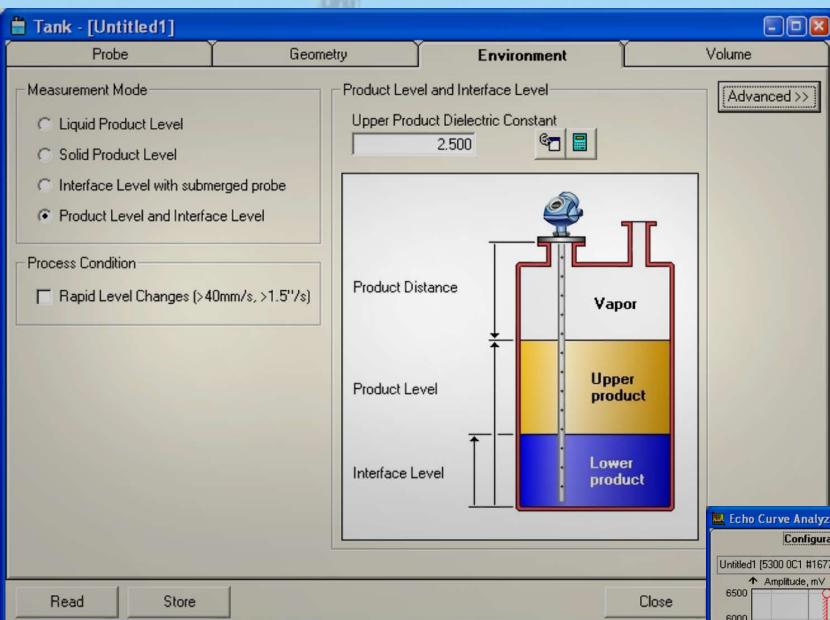

Rosemount Radar Master

Rosemount Radar Master is the ultimate setup software and supports both HART and FOUNDATION fieldbus. It provides easy configuration and service through a user-friendly interface with wizards, echo curve with movie features, offline/online configuration, extensive online help, logging capabilities and much more.

Our skilled engineers have worked hard to reduce your commissioning cost. Just mount the transmitter, power it up and connect Rosemount Radar Master to the loop to perform a complete transmitter configuration in a few simple steps.

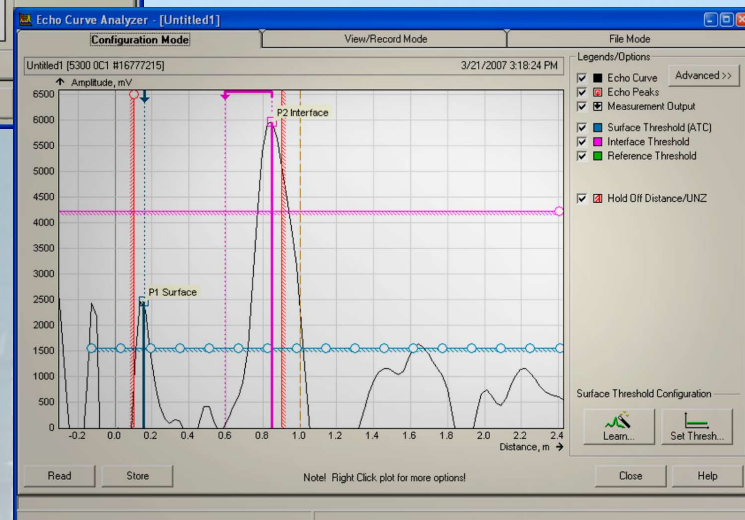

Other Easy-To-Use Configuration Tools

User-friendly interfaces are available in any host system that supports Device Descriptors (DD). In addition, the 5300 Series offers advanced configuration and extensive diagnostics in any host that supports enhanced EDDL, such as the 375 Field Communicator, AMS™ Suite: Device Manager or DeltaV™ system. The transmitter can also be ordered pre-configured from the factory.

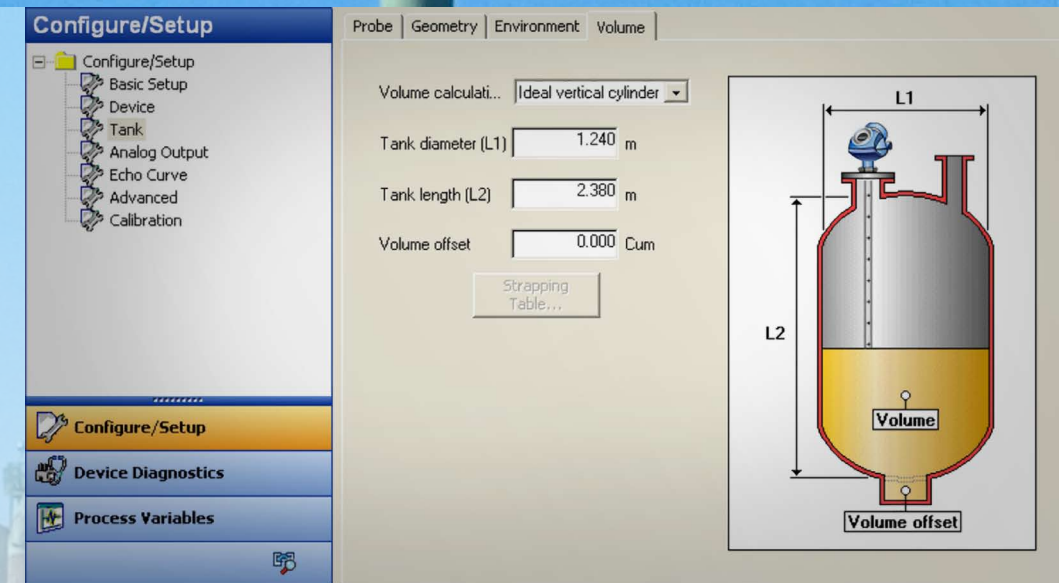

Echo Curve

The enhanced EDDL capabilities of the 5300 Series also make it possible to view the echo curve and to initiate the Measure-and-Learn functionality with a 375 Field Communicator or AMS Device Manager.



Experience lower costs and higher revenues with the Rosemount 5300

Standard 2-wire Guided Wave Radar benefits

- + No moving parts, no calibration, which minimizes maintenance requirements
- + Unaffected by changing process conditions such as density, conductivity, temperature and pressure
- + Virtually unaffected by dust, vapor and turbulence
- + Handles small tanks, difficult tank geometry, interfering obstacles
- + Easy swap (existing and small openings)

Add Rosemount 5300 benefits

- + Direct Switch Technology and Probe End Projection increase measurement reliability and capability
 - + Robust, Modular Design and Smart Galvanic Interface reduce cost and increase safety
 - + User-friendly configuration tools reduce startup cost and troubleshooting
 - + Powers PlantWeb with actionable diagnostics, MultiVariable and extensive FF capabilities
- = For your business, this all adds up to reduced cost of ownership, increased process availability, more satisfied customers and higher profits.

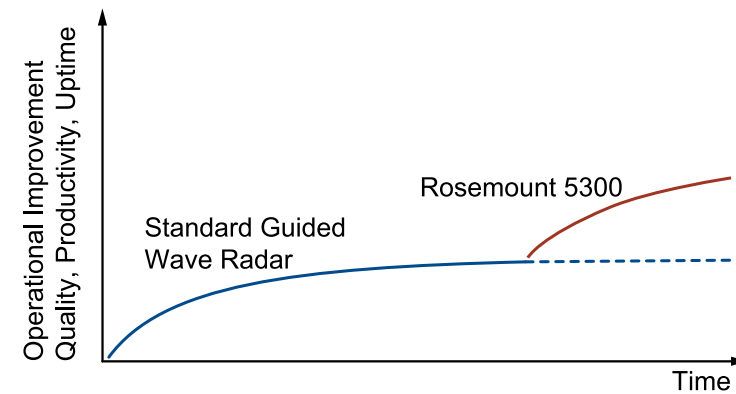

Key Specifications

Product	Model 5301 for level of liquids or submerged interfaces. Model 5302 for level and interface in liquids Model 5303 for level of solids
Measurement Principle	Time Domain Reflectometry (TDR)
Measuring Range	Up to 164 ft.. (50 m)
Dielectric Constant	Minimum 1.2 for coaxial probe or single probe installed in bypass, other probes from 1.4
Probe Materials	SST, Monel, Hastelloy, or PTFE-covered SST
Process Temperature	Up to 752° F (400° C). See PDS for complete data
Process Pressure	Up to 5000 psi (345 bar). See PDS for complete data
Output	Analog 4-20 mA, HART. FOUNDATION fieldbus.
Reference Accuracy	± 0.1 in. (± 3 mm) or ± 0.03% of measured distance, whichever is greatest
Repeatability	± 0.04 in. (1 mm)
Fieldbus Functionality	Link-master device (backup LAS), PlantWeb Alerts, Methods
Fieldbus Blocks	Resource, 3x Transducer, 6x Analog Input (30 ms), PID (40 ms), Arithmetic, Input Selector, Output Splitter (65 ms), Signal Characterizer (75 ms)
Configuration Tools	Rosemount Radar Master, 375 Field Communicator, AMS Suite: Intelligent Device Manager, DeltaV or any other DD- or EDDL-compatible host-system.

More than the world's most reliable Guided Wave Radar

For over 50 years, reliable Rosemount brand measurement products have been helping customers run their plants and processes safely and more efficiently. The success of Rosemount products is based in our commitment to product quality and reliability in the most demanding industry environments. Our ISO 9001-certified global manufacturing facilities can deliver Rosemount products when you need them, where you need them.

What's more, each Rosemount device has the full power of Emerson behind it, delivering the most complete solutions for all your process needs. Rosemount expertise and best-in-class technologies play a key role in Emerson's combining of superior products and technology with industry-specific engineering, consulting, project management and maintenance services. Wherever you are, there is an Emerson expert available to answer questions and help you implement solutions locally.

A COMPLETE PRODUCT RANGE FOR PROCESS LEVEL MEASUREMENT

ROSEMOUNT LEVEL MEASUREMENT TRANSMITTERS FROM EMERSON ARE DESIGNED TO CUT COSTS AND INCREASE SAFETY BY GIVING PRECISE AND RELIABLE LEVEL DATA UNDER MOST PROCESS CONDITIONS. BASED ON FIVE DIFFERENT MEASUREMENT PRINCIPLES – DIFFERENTIAL PRESSURE, NON-CONTACTING RADAR, GUIDED WAVE RADAR, ULTRASONIC AND VIBRATING FORK LEVEL SWITCH. FOR MORE INFORMATION PLEASE VISIT ROSEMOUNT.COM.



The Emerson logo is a trademark and service mark of Emerson Electric Co. Rosemount and the Rosemount logotype are registered trademarks of Rosemount Inc. PlantWeb is a registered trademark of the Emerson Process Management group of companies. All other marks are the property of their respective owners. ©2007 Rosemount Inc. All rights reserved. The contents of this publication are presented for information purposes only, and while effort has been made to ensure their accuracy, they are not to be construed as warranties or guarantees, expressed or implied, regarding the products or services described herein or their use or applicability. Standard Terms and Conditions of Sale can be found at www.rosemount.com/terms_of_sale. We reserve the right to modify or improve the designs or specifications of our products at any time without notice.

Emerson Process Management Rosemount Inc.

8200 Market Boulevard
Chanhassen, MN 55317 USA
T 1-(800)-999-9307
T (International) 1-(952)-906-8888
F 1-(952)-949-7001

www.rosemount.com

Emerson Process Management Shared Services, Ltd

Heath Place
Bognor Regis
West Sussex PO22 9SH
England
Tel +44 (0) 12430 863 121
Fax +44 (0) 12430 867 554

Emerson Process Management Asia Pacific Private Limited

1 Pandan Crescent
Singapore 128461
T (65) 6777 8211
F (65) 6777 0947
Enquiries@AP.EmersonProcess.com