

Instruction Manual

LIQ_MAN_5081A-FF/rev.M

January 2015

5081-A

FOUNDATION™ Fieldbus Two-Wire Chlorine, Dissolved Oxygen, and Ozone Transmitter



ESSENTIAL INSTRUCTIONS

READ THIS PAGE BEFORE PROCEEDING!

Rosemount Analytical designs, manufactures, and tests its products to meet many national and international standards. Because these instruments are sophisticated technical products, you must properly install, use, and maintain them to ensure they continue to operate within their normal specifications. The following instructions must be adhered to and integrated into your safety program when installing, using, and maintaining Rosemount Analytical products. Failure to follow the proper instructions may cause any one of the following situations to occur: Loss of life; personal injury; property damage; damage to this instrument; and warranty invalidation.

- Read all instructions prior to installing, operating, and servicing the product. If this Instruction Manual is not the correct manual, telephone 1-800-654-7768 and the requested manual will be provided. Save this Instruction Manual for future reference.
- If you do not understand any of the instructions, contact your Rosemount representative for clarification.
- Follow all warnings, cautions, and instructions marked on and supplied with the product.
- Inform and educate your personnel in the proper installation, operation, and maintenance of the product.
- Install your equipment as specified in the Installation Instructions of the appropriate Instruction Manual and per applicable local and national codes. Connect all products to the proper electrical and pressure sources.
- To ensure proper performance, use qualified personnel to install, operate, update, program, and maintain the product.
- When replacement parts are required, ensure that qualified people use replacement parts specified by Rosemount. Unauthorized parts and procedures can affect the product's performance and place the safe operation of your process at risk. Look alike substitutions may result in fire, electrical hazards, or improper operation.
- Ensure that all equipment doors are closed and protective covers are in place, except when maintenance is being performed by qualified persons, to prevent electrical shock and personal injury.

CAUTION

If a 375 or 475 Universal Communicator is used with these transmitters, the software within the 375 or 475 may require modification. If a software modification is required, please contact your local Emerson Process Management Service Group or National Response Center at 1-800-654-7768.

About This Document

This manual contains instructions for installation and operation of the Model 5081-A Foundation Fieldbus Two-Wire Chlorine, Dissolved Oxygen, and Ozone Transmitter. The following list provides notes concerning all revisions of this document.

Rev. Level	Date	Notes
A	6/02	This is the initial release of the product manual. The manual has been reformatted to reflect the Emerson documentation style and updated to reflect any changes in the product offering.
B	11/02	Revised drawings on pages 13-16.
C	1/03	Fixed minor typos.
D	4/03	Specs updates.
E	6/03	Agency certification update.
F	11/03	Updated Flat Mount drawing on page 10.
I	1/11	Removed "polyester" from enclosure specifications, updated © info
J	5/11	Updated Baseefa/Atex label drawing pg 24.
K	03/12	Update addresses - mail and web
L	11/12	Added Fieldbus specifications, updated ITK revision and CE certifications
M	10/14	Changed agency water exposure testing description to "Type".

Emerson Process Management

2400 Barranca Parkway
Irvine, CA 92606 USA
Tel: (949) 757-8500
Fax: (949) 474-7250

<http://www.rosemountanalytical.com>

© Rosemount Analytical Inc. 2014



EMERSON[™]
Process Management

5081-A MICROPROCESSOR TRANSMITTER

TABLE OF CONTENTS

Section	Title	Page
1.0	DESCRIPTION AND SPECIFICATIONS	1
1.1	Features and Applications.....	1
1.2	Specifications - General.....	2
1.3	Specifications - Oxygen	3
1.4	Specifications - Free Chlorine.....	3
1.5	Specifications - pH.....	3
1.6	Specifications - Total Chlorine.....	3
1.7	Specifications - Ozone	3
1.8	Transmitter Display During Calibration and Programming	4
1.9	Infrared Remote Controller	4
1.10	FOUNDATION Fieldbus	5
1.11	General Specifications.....	5
1.12	Asset Management Solutions (AMS).....	6
1.13	Ordering Information	8
1.14	Accessories	8
2.0	INSTALLATION	9
2.1	Unpacking and Inspection.....	9
2.2	Orienting the Display Board	9
2.3	Installation.....	9
2.4	Power Supply Wiring.....	12
3.0	WIRING.....	13
3.1	Wiring Model 499A Oxygen, Chlorine, and Ozone Sensors	13
3.2	Wiring Model 499ACL-01 (Free Chlorine) Sensors and pH Sensors.....	14
3.3	Wiring Model Hx438 and Gx448 Sensors.....	16
4.0	INTRINSICALLY SAFE AND EXPLOSION PROOF INSTALLATIONS.....	17
5.0	DISPLAY AND OPERATION WITH INFRARED REMOTE CONTROLLER.....	31
5.1	Display Screens	31
5.2	Infrared Remote Controller (IRC) - Key Functions.....	32
5.3	Menu Tree.....	33
5.4	Diagnostic Messages.....	33
5.5	Security	33
5.6	Using Hold	33
6.0	OPERATION WITH FOUNDATION FIELDBUS AND THE DELTAV CONTROL SYSTEM .	35
6.1	Overview	35
6.2	AI Block Configuration	36
6.3	Transducer Block Operations — Configuration and Calibration	37
6.4	Model 5081-A-FF — Device Summary	38

TABLE OF CONTENTS CONT'D

Section	Title	Page
7.0	PROGRAMMING	42
7.1	General	42
7.2	Default Settings.....	42
7.3	Temperature Settings.....	44
7.4	Display	46
7.5	Calibration SetUp.....	48
7.6	Line Frequency	51
7.7	pH Measurement	52
7.8	Barometric Pressure	56
8.0	CALIBRATION — TEMPERATURE	58
8.1	Introduction	58
8.2	Procedure using the infrared remote controller.....	59
8.3	Procedure using DeltaV	59
9.0	CALIBRATION — OXYGEN	60
9.1	Introduction	60
9.2	Procedure — Zeroing the Sensor using the infrared remote controller	61
9.3	Procedure — Zeroing the Sensor using DeltaV.....	62
9.4	Procedure — Air Calibration using the infrared remote controller.....	63
9.5	Procedure — Air Calibration using DeltaV	64
9.6	Procedure — In-Process Calibration using the infrared remote controller.....	65
9.7	Procedure — In-Process Calibration using DeltaV	66
10.0	CALIBRATION — FREE CHLORINE	67
10.1	Introduction	67
10.2	Procedure — Zeroing the Sensor using the infrared remote controller	68
10.3	Procedure — Zeroing the Sensor using DeltaV.....	69
10.4	Procedure — Full Scale Calibration using the infrared remote controller.....	70
10.5	Procedure — Full Scale Calibration using DeltaV	71
10.6	Dual Slope Calibration	72
11.0	CALIBRATION — TOTAL CHLORINE	74
11.1	Introduction	74
11.2	Procedure — Zeroing the Sensor using the infrared remote controller	75
11.3	Procedure — Zeroing the Sensor using DeltaV.....	76
11.4	Procedure — Full Scale Calibration using the infrared remote controller.....	77
11.5	Procedure — Full Scale Calibration using DeltaV	78
11.6	Dual Slope Calibration	79
12.0	CALIBRATION — OZONE	81
12.1	Introduction	81
12.2	Procedure — Zeroing the Sensor using the infrared remote controller	82
12.3	Procedure — Zeroing the Sensor using DeltaV.....	82
12.4	Procedure — Full Scale Calibration using the infrared remote controller.....	84
12.5	Procedure — Full Scale Calibration using DeltaV	85

TABLE OF CONTENTS CONT'D

Section	Title	Page
13.0	CALIBRATION — pH	86
13.1	Introduction	86
13.2	Procedure — Auto Calibration using the infrared remote controller.....	87
13.3	Procedure — Auto Calibration using DeltaV	88
13.4	Procedure — Manual Calibration using the infrared remote controller	89
13.5	Procedure — Manual Calibration using DeltaV	90
13.6	Standardization using the infrared remote controller	91
13.7	Standardization using DeltaV.....	92
13.8	pH Slope Adjustment using the infrared remote controller.....	93
13.9	pH Slope Adjustment using DeltaV	94
14.0	DIAGNOSTICS	95
14.1	General	95
14.2	Diagnostic Messages for Dissolved Oxygen.....	95
14.3	Diagnostic Messages for Ozone and Total Chlorine	95
14.4	Diagnostic Messages for Free Chlorine.....	96
15.0	TROUBLESHOOTING	97
15.1	Warning and Fault Messages	97
15.2	Troubleshooting When a Warning or Fault Message is Showing	99
15.3	Temperature Measurement and Calibration Problems	102
15.4	Oxygen Measurement and Calibration Problems	103
15.5	Free Chlorine Measurement and Calibration Problems.....	105
15.6	Total Chlorine Measurement and Calibration Problems.....	107
15.7	Ozone Measurement and Calibration Problems	108
15.8	pH Measurement and Calibration Problems	110
15.9	Simulating Input Currents — Dissolved Oxygen.....	112
15.10	Simulating Input Currents — Chlorine and Ozone.....	112
15.11	Simulating Inputs — pH	113
15.12	Simulating Temperature	114
15.13	Measuring Reference Voltage.....	115
16.0	MAINTENANCE	116
16.1	Overview	116
16.2	Transmitter Maintenance	116
17.0	RETURN OF MATERIAL	118
Appendix	Title	Page
A	BAROMETRIC PRESSURE AS A FUNCTION OF ALTITUDE	119

LIST OF TABLES

Number	Title	Page
6-1	Analog Input Block Configuration Values	36
6-2	Model 5081-A-FF Parameters and Methods	39
7-1	Default Settings	42
16-1	Replacement Parts for Model 5081-A Transmitter	117

LIST OF FIGURES

Number	Title	Page
1-1	Transmitter Display During Calibration and Programming.....	4
1-2	Infrared Remote Controller	4
1-3	Functional Block Diagram for the Model 5081-A-FF Transmitter.....	5
1-4	Asset Management Solutions (AMS) Configuration Screen	5
1-5	Asset Management Solutions (AMS) Measurement Screen	6
1-6	Model 5081-A Mounting and Dimensional Drawings	7
2-1	Mounting the Model 5081-A on a Flat Surface	10
2-2	Using the Pipe Mounting Kit to attach the Model 5081-A to a pipe.....	11
2-3	Power Supply Wiring	12
2-4	Typical Fieldbus Network Electrical Wiring Configuration.....	12
3-1	Amperometric sensors with standard cable.....	13
3-2	Amperometric sensors with optimum EMI/RFI cable or Variopol cable	13
3-3	Free Chlorine sensor with standard cable and 399VP-09 pH sensor without internal preamplifier	14
3-4	Free Chlorine sensor with standard cable and 399-14 pH sensor with internal preamplifier..	14
3-5	Free Chlorine sensor with standard cable and 399-09-62 pH sensor without internal preamplifier	15
3-6	Free Chlorine sensor with optimum EMI/RFI cable or Variopol cable and 399VP-09 pH sensor without internal preamplifier	15
3-7	Free Chlorine sensor with optimum EMI/RFI cable or Variopol cable and 399-14 pH sensor with internal preamplifier.....	15
3-8	Free Chlorine sensor with optimum EMI/RFI cable or Variopol cable and 399-09-62 pH sensor without internal preamplifier	15
3-9	Hx438 and Gx448 sensors	16
4-1	FMRC Explosion-Proof Installation.....	17
4-2	FM Intrinsically-Safe Installation Label	18
4-3	FM Intrinsically-Safe Installation	19
4-4	CSA Intrinsically-Safe Installation Label	21
4-5	CSA Intrinsically-Safe Installation	22
4-6	BASEEFA/ATEX Intrinsically-Safe Installation Label	24
4-7	Process Display Screen.....	25
4-8	CSA Intrinsically-Safe Installation (1 of 2).....	26
4-9	BAS/ATEX Intrinsically-Safe Label 5081-A-FI	27
4-10	FM Intrinsically-Safe Installation 5081-A-FI	28
5-1	Process Display Screen.....	31
5-2	Program Display Screen.....	31
5-3	Infrared Remote Controller	32
5-4	Menu Tree.....	34
6-1	Functional Block Diagram for the Model 5081-A-FF Transmitter.....	35
9-1	Sensor Current as a Function of Dissolved Oxygen Concentration	60
10-1	Sensor Current as a Function of Free Chlorine Concentration.....	67
10-2	Dual Slope Calibration	72
11-1	Determination of Total Chlorine.....	74
11-2	Sensor Current as a Function of Total Chlorine Concentration.....	74
11-3	Dual Slope Calibration	79
12-1	Sensor Current as a Function of Ozone Concentration.....	80
13-1	Calibration Slope and Offset	86
15-1	Simulate dissolved oxygen	112
15-2	Simulate chlorine and ozone	112
15-3	Simulate pH	113
15-4	Three-wire RTD Configuration.....	114
15-5	Simulating RTD Inputs.....	114
15-6	Checking for a Poisoned Reference Electrode.....	115
16-1	Exploded View of Model 5081-A Transmitter	116

SECTION 1.0 DESCRIPTION AND SPECIFICATIONS

- MEASURES dissolved oxygen (ppm and ppb level), free chlorine, total chlorine, and ozone.
- SECOND INPUT FOR pH SENSOR ALLOWS AUTOMATIC pH CORRECTION for free chlorine measurement. No expensive reagents needed.
- AUTOMATIC BUFFER RECOGNITION for pH calibration.
- ROBUST TYPE 4X ENCLOSURE protects the transmitter from hostile environments.
- USES FOUNDATION FIELDBUS® DIGITAL COMMUNICATIONS.



1.1 FEATURES AND APPLICATIONS

The 5081-A Transmitter with the appropriate sensor measures dissolved oxygen (ppm and ppb level), free chlorine, total chlorine, and ozone in a variety of process liquids. The transmitter is compatible with Rosemount Analytical 499A amperometric sensors for oxygen, chlorine, and ozone; and with Hx438 and Gx448 steam-sterilizable oxygen sensors.

For free chlorine measurements, both automatic and manual pH correction are available. pH correction is necessary because amperometric chlorine sensors respond only to hypochlorous acid, not free chlorine, which is the sum of hypochlorous acid and hypochlorite ion. To measure free chlorine, most competing instruments require an acidified sample. Acid lowers the pH and converts hypochlorite ion to hypochlorous acid. The Model 5081-A eliminates the need for messy and expensive sample conditioning by using the sample pH to correct the chlorine sensor signal. If the pH is relatively constant, a fixed pH correction can be used. If the pH is greater than 7.0 and fluctuates more than about 0.2 units, continuous measurement of pH and automatic pH correction is necessary. Corrections are valid to pH 9.5.

The transmitter fully compensates oxygen, ozone, free chlorine, and total chlorine readings for changes in membrane permeability caused by temperature changes.

For pH measurements — pH is available with free chlorine only — the 5081-A features automatic buffer recognition and stabilization check. Buffer pH and temperature data for commonly used buffers are stored in the analyzer. Glass impedance diagnostics warn the user of an aging or failed pH sensor.

Data are displayed in 0.8 in. (20 mm) high seven-segment numerals. pH (chlorine only) and temperature appear in 0.3 inch (7 mm) high digits.

The transmitter has a rugged, weatherproof, corrosion-resistant enclosure (Type 4X and IP65) of epoxy-painted aluminum. The enclosure also meets explosion-proof standards.

The transmitter uses FOUNDATION Fieldbus digital communication. Digital communications allows access to AMS (Asset Management Solutions). Use AMS to set up and configure the transmitter, read process variables, and troubleshoot problems from a personal computer anywhere in the plant.

A handheld infrared remote controller or the 375 or 475 communicator can also be used for programming.

® FOUNDATION is a registered trademark of Fieldbus Foundation.

1.2 SPECIFICATIONS - GENERAL

Housing: Cast aluminum with epoxy coating.
Type 4X (IP65). Neoprene O-ring cover seals.

Dimensions: 160.5 mm x 175.3 mm x 161.3 mm (6.3 in. x 6.9 in. x 6.4 in.) See drawing.

Conduit Openings: 3/4-in. FNPT

Ambient Temperature: -4 to 149°F (-20 to 65°C)

Storage Temperature: -22 to 176°F (-30 to 80°C)

Relative Humidity: 0 to 95% (non-condensing)

Weight/Shipping Weight: 10 lb/10 lb (4.5/5.0 kg)

Display: Two-line LCD; first line shows process variable (oxygen, ozone, or chlorine), second line shows temperature and output current. For pH/chlorine combination, the second line can be toggled to show pH. Fault and warning messages, when triggered, alternate with temperature and output readings.

Process variable: 7 segment LCD, 0.8 in. (20 mm) high.

Temperature/output/pH: 7 segment LCD, 0.3 in. (7mm) high.

Display board can be rotated 90 degrees clockwise or counterclockwise.

During calibration and programming, messages and prompts appear in the second line.

Temperature range: 0-100°C (0-150°C for steam sterilizable sensors)

Temperature resolution: 0.1°C

Accuracy using RTD: ±0.5°C between 0 and 50°C, ±1°C above 50°C

Accuracy using 22k NTC: ±0.5°C between 0 and 50°C, ±2°C above 50°C

RFI/EMI: EN-61326 

HAZARDOUS AREA CLASSIFICATION:

Intrinsic Safety:



Class I, II, III, Div. 1
Groups A-G
T4 Tamb = 70°C



Exia Entity
Class I, Groups A-D
Class II, Groups E-G
Class III
T4 Tamb = 70°C

ATEX



CE 0600 II 1 G
Baseefa02ATEX1284
EEx ia IIC T4
Tamb = -20°C to +65°C



IECEX BAS 09.0159X
Ex ia IIC T4 Ga

ATEX and IECEx Special Conditions for Use: The model 5081 enclosure is made of aluminum alloy and is given a protective polyurethane paint finish. However, care should be taken to protect it from impact or abrasion if located in a zone 0 hazardous area.

Non-Incendive:



Class I, Div. 2, Groups A-D
Dust Ignition Proof
Class II & III, Div. 1, Groups E-G
Type 4X Enclosure



Class I, Div. 2, Groups A-D
Suitable for Class II, Div. 2, Groups E-G
T4 Tamb = 70°C

Explosion-Proof:



Class I, Div. 1, Groups B-D
Class II, Div. 1, Groups E-G
Class III, Div. 1



Class I, Groups B-D
Class II, Groups E-G
Class III
Tamb = 65°C max

Repeatability (input): ±0.1% of range

Linearity (input): ±0.3% of range

Input Ranges: 0-330 nA, 0.3-4 µA, 3.7-30 µA,
27-100 µA

FOUNDATION Fieldbus:

Four (4) AI blocks assignable to measurement (oxygen, ozone, or chlorine), temperature, pH, and sensor current.

1.3 SPECIFICATIONS — OXYGEN**Measurement Range:** 0-99 ppm (mg/L), 0-200% saturation**Resolution:** 0.01 ppm, 0.1 ppb for 499A TrDO sensor**Temperature correction for membrane permeability:** automatic between 0 and 50°C (can be disabled)**Calibration:** air calibration (user must enter barometric pressure) or calibration against a standard instrument**SENSORS — OXYGEN:**

Model 499A DO-54 for ppm level

Model 499A TrDO-54 for ppb level

Hx438 and Gx448 steam-sterilizable oxygen sensors

1.4 SPECIFICATIONS — FREE CHLORINE**Measurement Range:** 0-20 ppm (mg/L) as Cl₂**Resolution:** 0.001 ppm (Autoranges at 0.999 to 1.00 and 9.99 to 10.0)**Temperature correction for membrane permeability:** automatic between 0 and 50°C (can be disabled)**pH Correction:** Automatic between pH 6.0 and 9.5. Manual pH correction is also available.**Calibration:** against grab sample analyzed using portable test kit.**SENSOR — FREE CHLORINE:**

Model 499A CL-01-54

1.5 SPECIFICATIONS — pH**Application:** pH measurement available with free chlorine only**Measurement Range:** 0-14 pH**Resolution:** 0.01 pH**Sensor Diagnostics:** Glass impedance (for broken or aging electrode) and reference offset. Reference impedance (for fouled reference junction) is not available.**Repeatability:** ±0.01 pH at 25°C**SENSORS — pH:**

Use Model 399-09-62, 399-14, or 399VP-09.

See pH sensor product data sheet for complete ordering information.

1.6 SPECIFICATIONS — TOTAL CHLORINE**Measurement Range:** 0-20 ppm (mg/L) as Cl₂**Resolution:** 0.001 ppm (Autoranges at 0.999 to 1.00 and 9.99 to 10.0)**Temperature correction for membrane permeability:** automatic between 5 and 35°C (can be disabled)**Calibration:** against grab sample analyzed using portable test kit.**SENSOR — TOTAL CHLORINE:**

Model 499A CL-02-54 (must be used with SCS 921)

1.7 SPECIFICATIONS — OZONE**Measurement Range:** 0-10 ppm (mg/L)**Resolution:** 0.001 ppm (Autoranges at 0.999 to 1.00 and 9.99 to 10.0)**Temperature correction for membrane permeability:** automatic between 5 and 35°C (can be disabled)**Calibration:** against grab sample analyzed using portable test kit.**SENSOR — OZONE:**

Model 499A OZ-54

ACCESSORIES**POWER SUPPLY:** Use the Model 515 Power Supply to provide dc loop power to the transmitter. The Model 515 provides two isolated sources at 24Vdc and 200 mA each. For more information refer to product data sheet 71-515.

1.8 TRANSMITTER DISPLAY DURING CALIBRATION AND PROGRAMMING (Figure 1-1)

1. Continuous display of oxygen, chlorine, or ozone reading.
2. Units: ppm, ppb, or % saturation.
3. Current menu appears here.
4. Submenus, prompts, and diagnostic readings appear here.
5. Commands available in each submenu or at each prompt appear here.
6. Hold appears when the transmitter is in hold.
7. Fault appears when the transmitter detects a sensor or instrument fault.

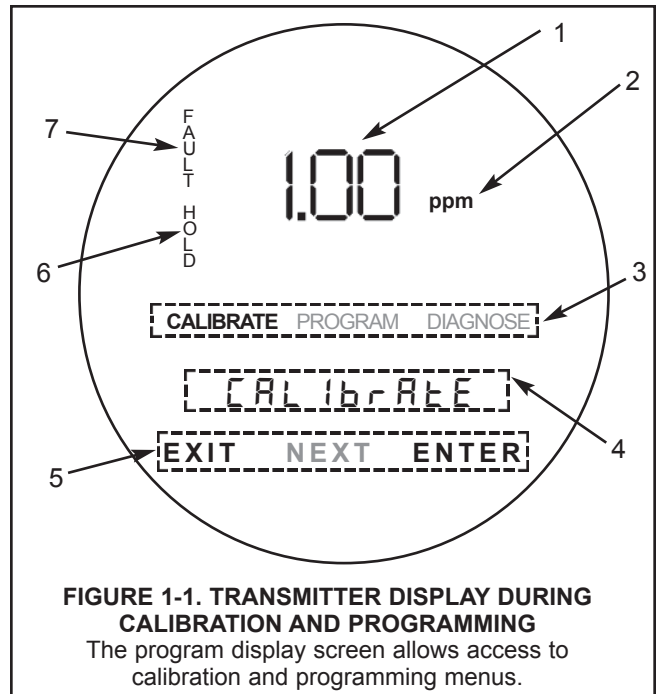

1.9 INFRARED REMOTE CONTROLLER (Figure 1-2)

1. Pressing a menu key allows the user access to calibrate, program, or diagnostic menus.
2. Press ENTER to store data and settings. Press NEXT to move from one submenu to the next. Press EXIT to leave without storing changes.
3. Use the editing keys to scroll through lists of allowed settings or to change a numerical setting to the desired value.
4. Pressing HOLD puts the transmitter in hold and sends the output current to a pre-programmed value. Pressing RESET causes the transmitter to abandon the present operation and return to the main display.

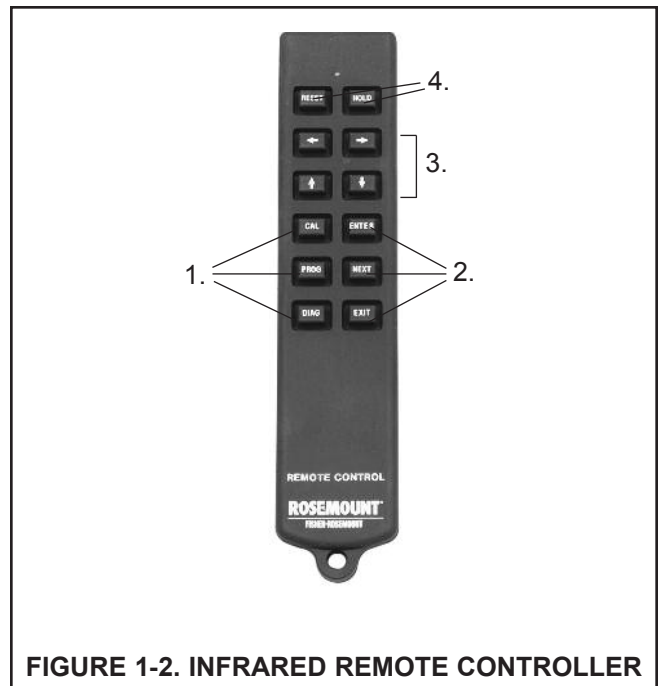

1.10 FOUNDATION FIELDBUS (FIGURE 1-3)

Figure 1-3 is the block diagram for the 5081-A-FF transmitter. AMS Inside from Rosemount Analytical allows plant personnel to read process variables and completely configure FOUNDATION Fieldbus transmitters.

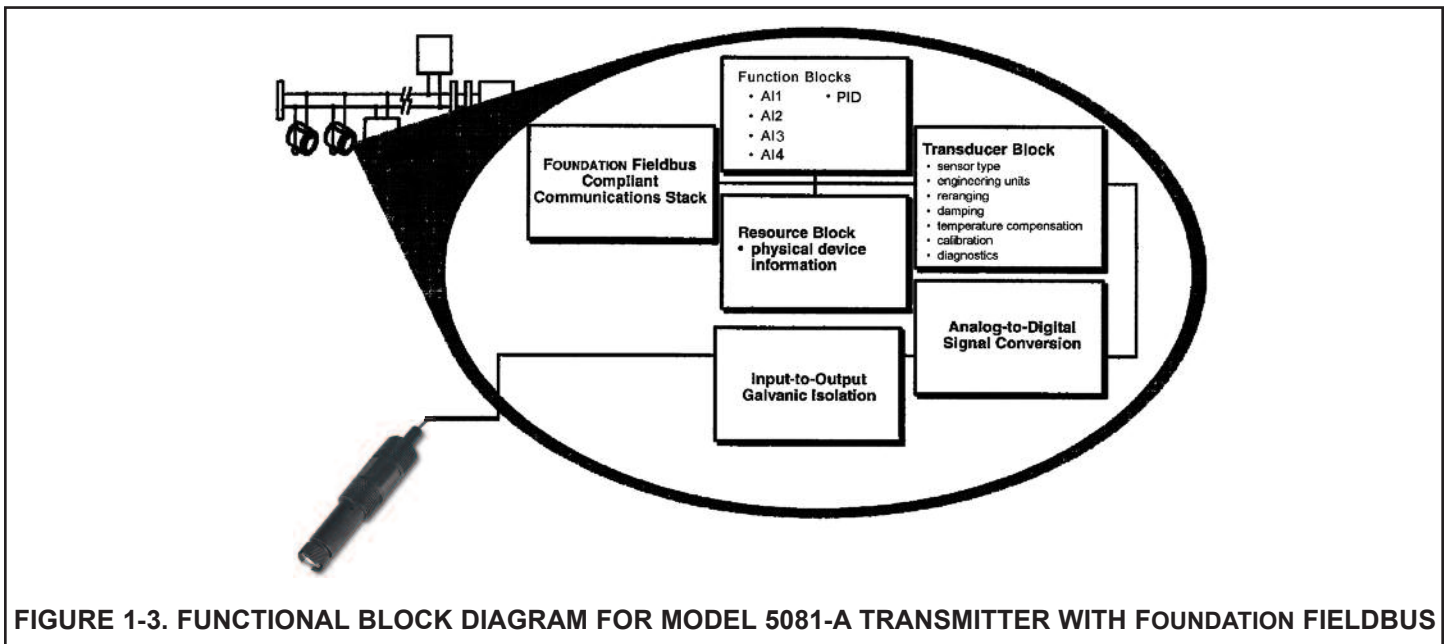

FIGURE 1-3. FUNCTIONAL BLOCK DIAGRAM FOR MODEL 5081-A TRANSMITTER WITH FOUNDATION FIELDBUS

1.11 GENERAL SPECIFICATIONS

Model: 5081-A-FF Amperometric Fieldbus transmitter

Type: Oxygen, Chlorine and Ozone Transmitter

Device ITK Profile: 6 (Released for ITK 6.0.0 / 6.0.1)

Manufacturer Identification (MANUFAC_ID): 0x524149

Device Type (DEV_TYPE): 0x4083

Device Revision (DEV_REV): 0x03

Linkmaster: Yes

Number of Link Objects: 20

VCR's supported: 20

Mandatory Features:

- Resource Block
- Alarm and Events
- Function Block Linking
- Trending
- Multi-Bit Alert Reporting
- Field Diagnostics

Additional Features:

- Common Software Download
- Block Instantiation
- Supports DeltaV Auto Commissioning

- Supports DeltaV Auto Replacement
- Supports DeltaV Firmware Live Download
- PlantWeb Alerts with re-annunciation / multibit
- Supports Easy Configuration Assistant

Function Blocks (Execution Time):

- 4 – Analog Input Blocks (15 mseconds)
- AI Block Channels:
 - Channel 1: Oxygen, Chlorine, Ozone
 - Channel 2: Temperature
 - Channel 3: Sensor Current
 - Channel 4: pH (Free Chlorine only)
- Proportional Integral Derivative (25 mseconds)

Power:

- Two Wire Device; Fieldbus Polarity Insensitive
- Current Draw: 21 mA
- Device Certifications: IS / FISCO
- Maximum certified input Voltage for IS: 30V
- Maximum certified input current for IS: 300mA
- Maximum certified input power for IS: 1.3W
- Internal Capacitance (Ci): 0 nF
- Internal Inductance (Li): 0 μ H

1.12 ASSET MANAGEMENT SOLUTIONS (AMS) (FIGURE 1-4)

Rosemount Analytical AMS windows provide access to all transmitter measurement and configuration variables. The user can read raw data, final data, and program settings and can reconfigure the transmitter from anywhere in the plant. Figures 1-4 and 1-5 show two of the many configuration and measurement screens available.

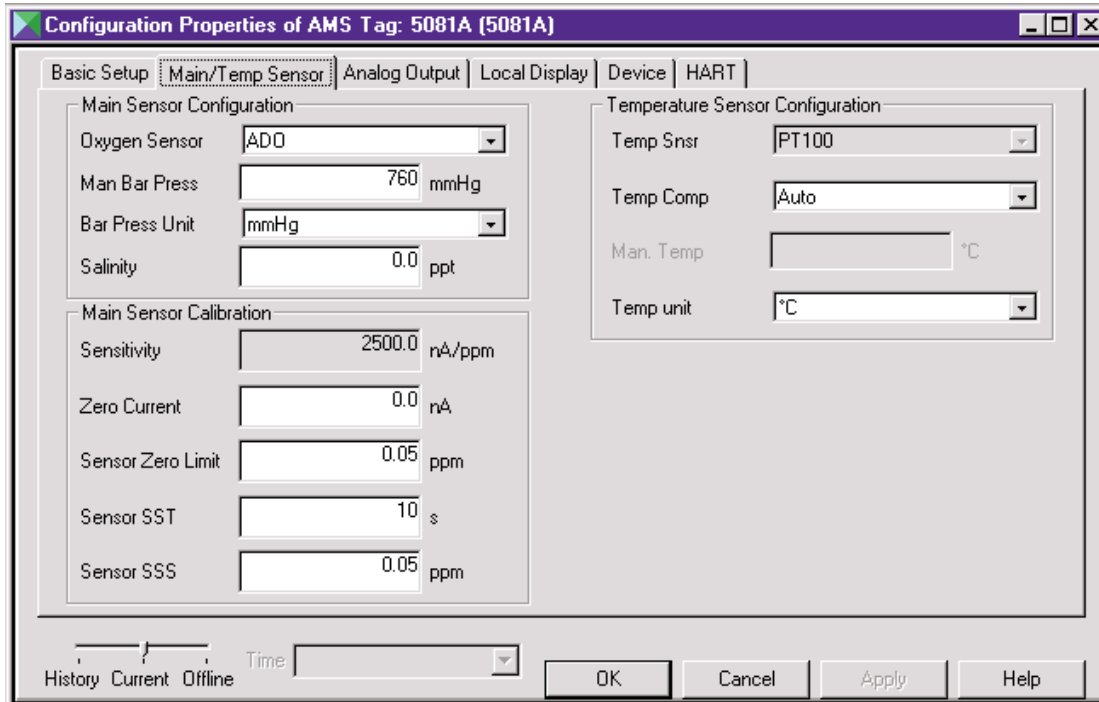

FIGURE 1-4. ASSET MANAGEMENT SOLUTIONS (AMS) CONFIGURATION SCREEN

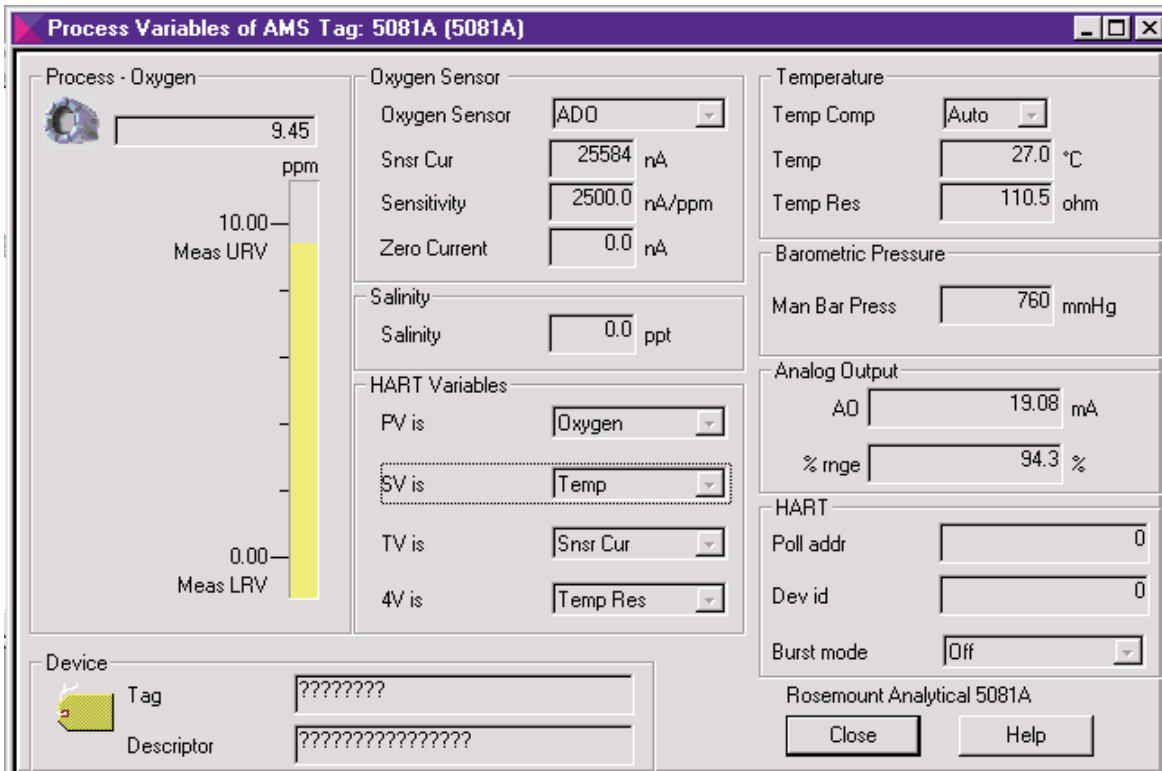

FIGURE 1-5. ASSET MANAGEMENT SOLUTIONS (AMS) MEASUREMENT SCREEN

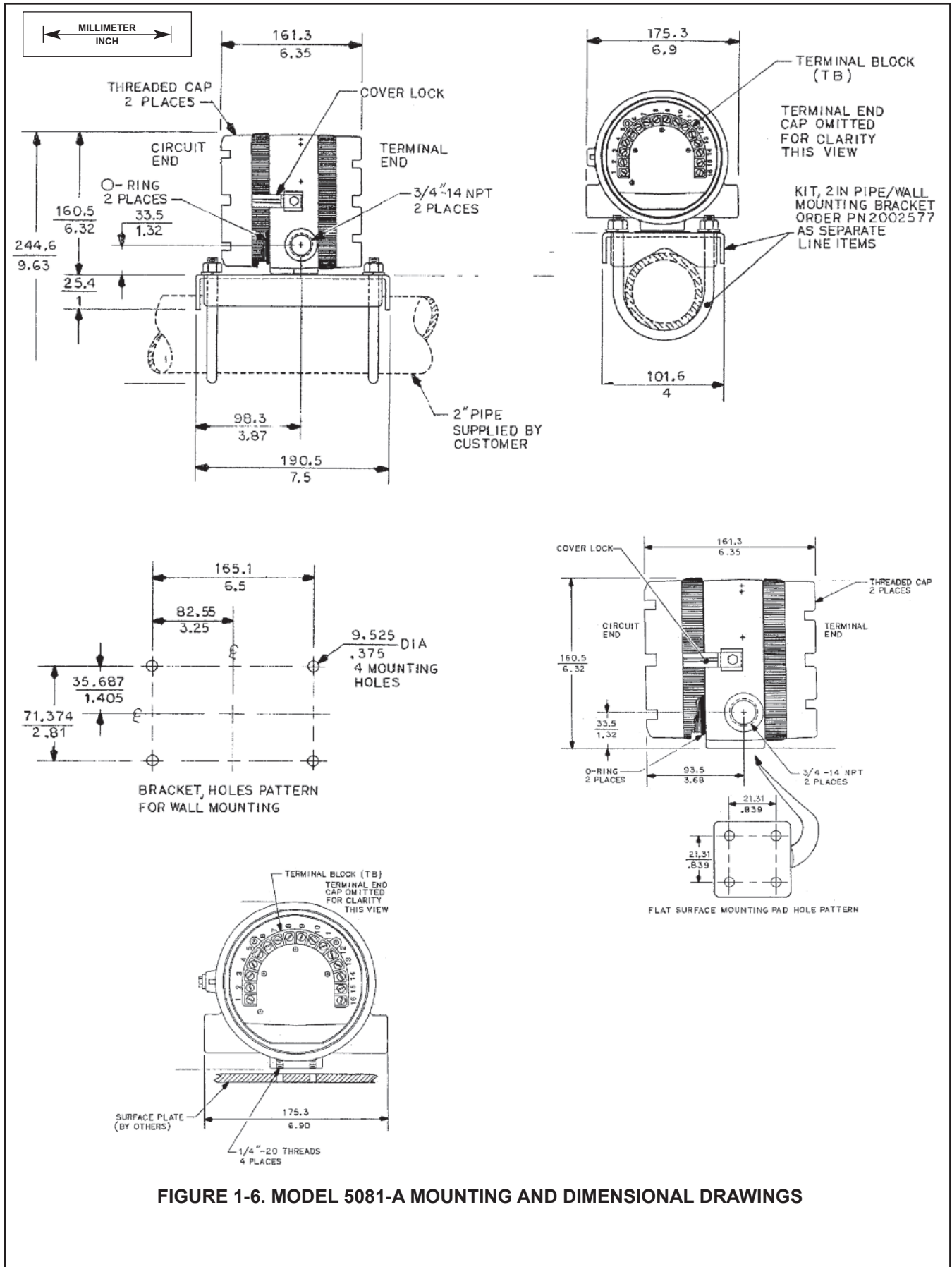

FIGURE 1-6. MODEL 5081-A MOUNTING AND DIMENSIONAL DRAWINGS

1.13 ORDERING INFORMATION

The **Model 5081-A Transmitter** is intended for the determination of oxygen (ppm and ppb level), free chlorine, total chlorine, and ozone. For free chlorine measurements, which often require continuous pH correction, a second input for a pH sensor is available. The transmitter is housed in a weatherproof, corrosion-resistant enclosure. A hand-held infrared remote controller is required to configure and calibrate the transmitter.

MODEL	
5081-A	SMART TWO-WIRE MICROPROCESSOR TRANSMITTER
CODE	REQUIRED SELECTION
FF	Foundation Fieldbus digital output
CODE	REQUIRED SELECTION
20	Infrared remote controller included
21	Infrared remote controller not included
CODE	AGENCY APPROVALS
60	No approval
5081-A	-FF -20 -60 EXAMPLE

1.14 ACCESSORIES

MODEL/PN	DESCRIPTION
515	DC loop power supply (see product data sheet 71-515)
24479-00	Infrared remote controller (required, one controller can operate any 5081 transmitter)
2002577	2-in. pipe mounting kit
9241178	Stainless steel tag, specify marking
AMS software	To order AMS software, call Rosemount Measurement at (800) 999-9307

SECTION 2.0 INSTALLATION

- 2.1 Unpacking and inspection**
- 2.2 Orienting the display board**
- 2.3 Installation**
- 2.4 Power supply wiring**

2.1 UNPACKING AND INSPECTION

Inspect the shipping container. If it is damaged, contact the shipper immediately for instructions. Save the box. If there is no apparent damage, remove the transmitter. Be sure all items shown on the packing list are present. If items are missing, notify Rosemount Analytical immediately.

2.2 ORIENTING THE DISPLAY BOARD

The display board can be rotated 90 degrees, clockwise or counterclockwise, from the original position. To reposition the display:

1. Loosen the cover lock nut until the tab disengages from the end, Unscrew the cap.
2. Remove the three bolts holding the circuit board stack.
3. Lift and rotate the display board 90 degrees into the desired position.
4. Position the display board on the standoffs. Replace and tighten the bolts.
5. Replace the end cap.

2.3 INSTALLATION

2.3.1 General information

1. The transmitter tolerates harsh environments. For best results, install the transmitter in an area where temperature extremes, vibrations, and electromagnetic and radio frequency interference are minimized or absent.
2. To prevent unintentional exposure of the transmitter circuitry to the plant environment, keep the cover lock in place over the circuit end cap. See Figure 2-1. To remove the circuit end cap loosen the lock nut until the tab disengages from the cap. Then unscrew the cover.
3. The transmitter has two $\frac{3}{4}$ -inch conduit openings, one on each side of the housing. See Figure 2-1.
4. Use weathertight cable glands to keep moisture out of the analyzer. If both a chlorine and pH sensor are being used, install a cable gland with a dual hole seal insert.
5. If conduit is used, plug and seal the connections at the transmitter housing to prevent moisture from getting inside the transmitter.

NOTE

Moisture allowed to accumulate in the housing can affect the performance of the transmitter and may void the warranty.

2.3.2 Mounting on a flat surface.

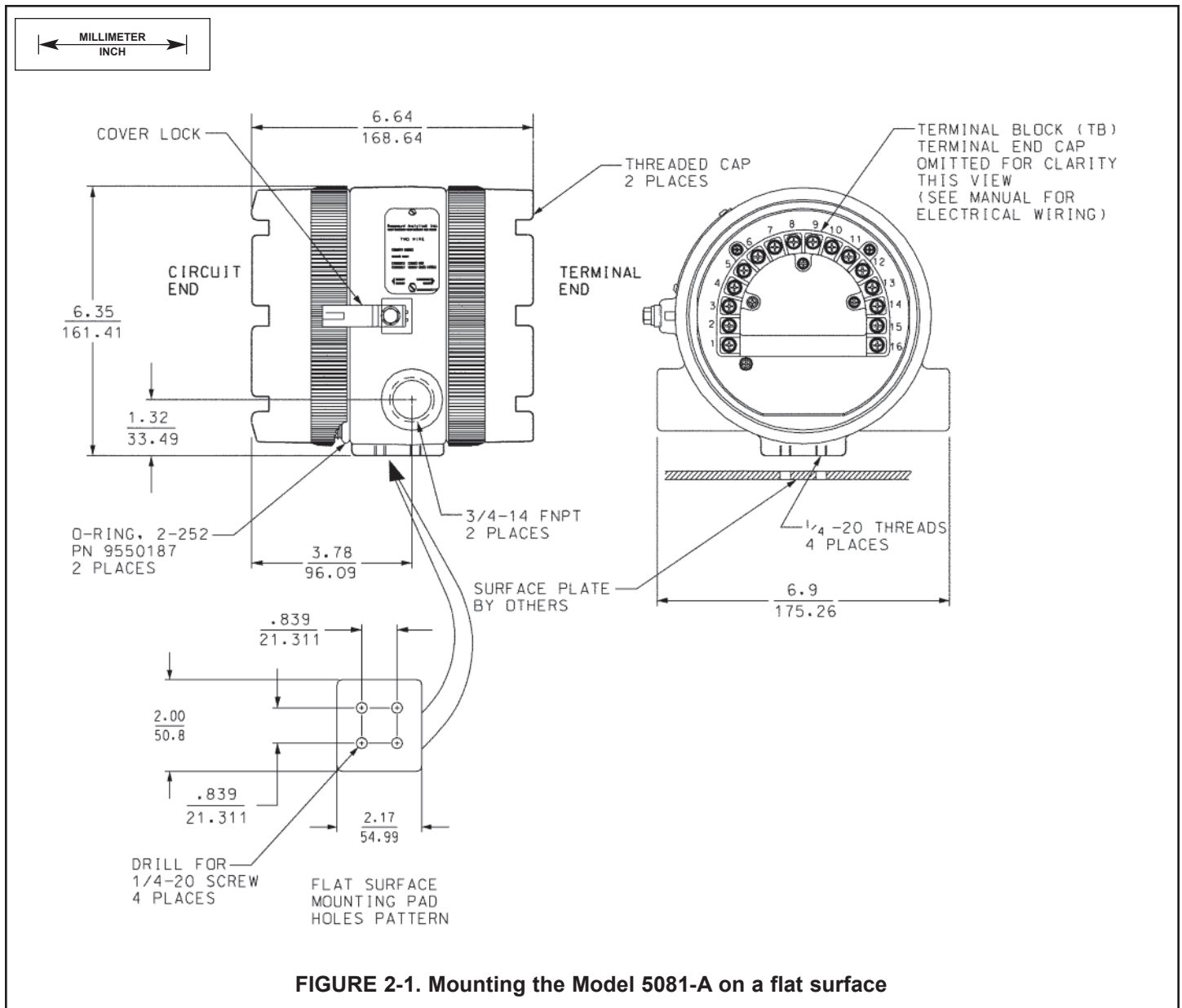

2.3.3 Pipe Mounting.

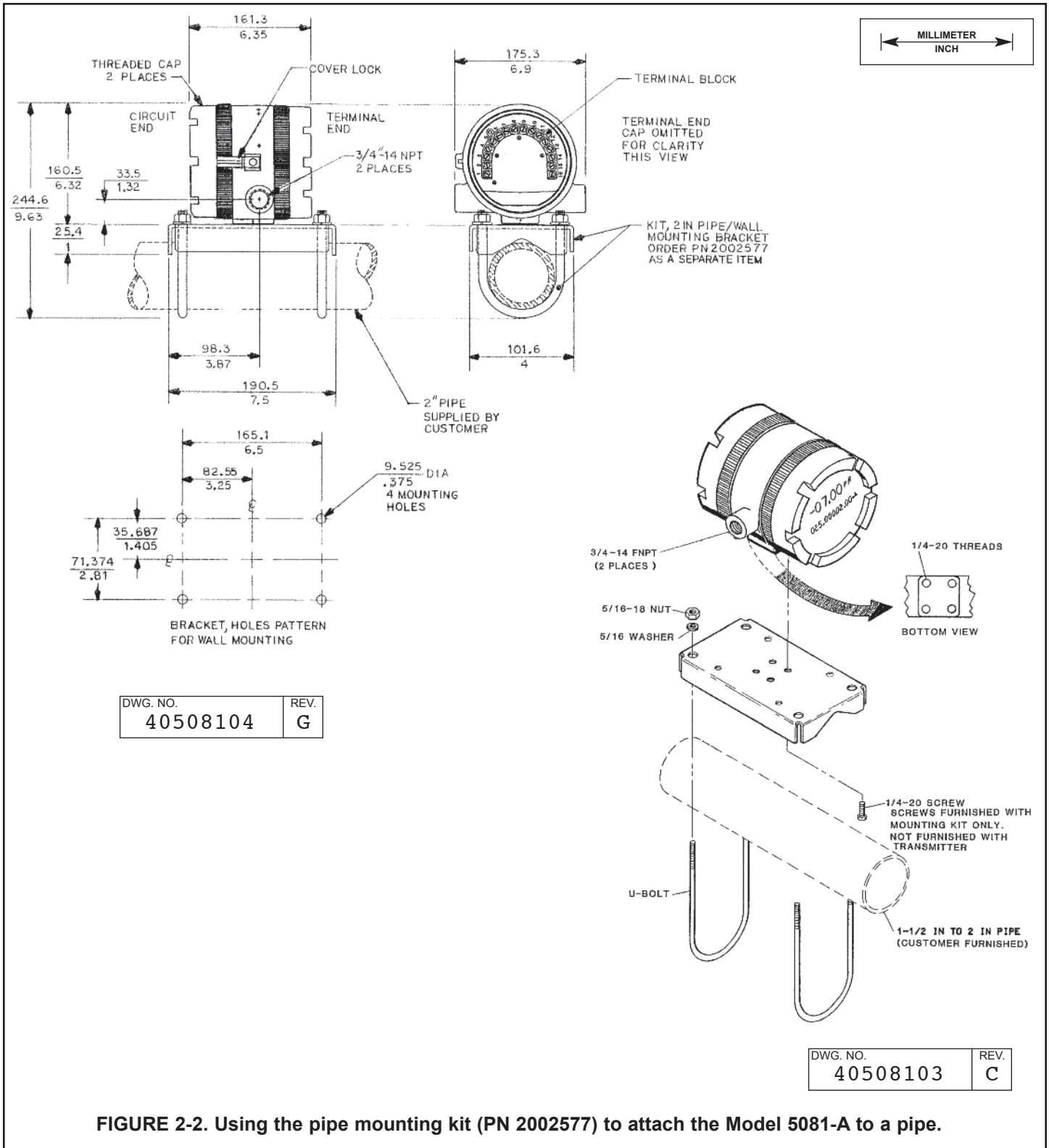

FIGURE 2-2. Using the pipe mounting kit (PN 2002577) to attach the Model 5081-A to a pipe.

2.4 POWER SUPPLY WIRING

Refer to Figures 2-3 and 2-4.

Run the power/signal wiring through the opening nearest terminals 15 and 16. Use shielded cable and ground the shield at the power supply. To ground the transmitter, attach the shield to the grounding screw on the inside of the transmitter case. A third wire can also be used to connect the transmitter case to earth ground.

NOTE

For optimum EMI/RFI immunity, the power supply/output cable should be shielded and enclosed in an earth-grounded metal conduit.

Do not run power supply/signal wiring in the same conduit or cable tray with AC power lines or with relay actuated signal cables. Keep power supply/signal wiring at least 6 ft (2 m) away from heavy electrical equipment.

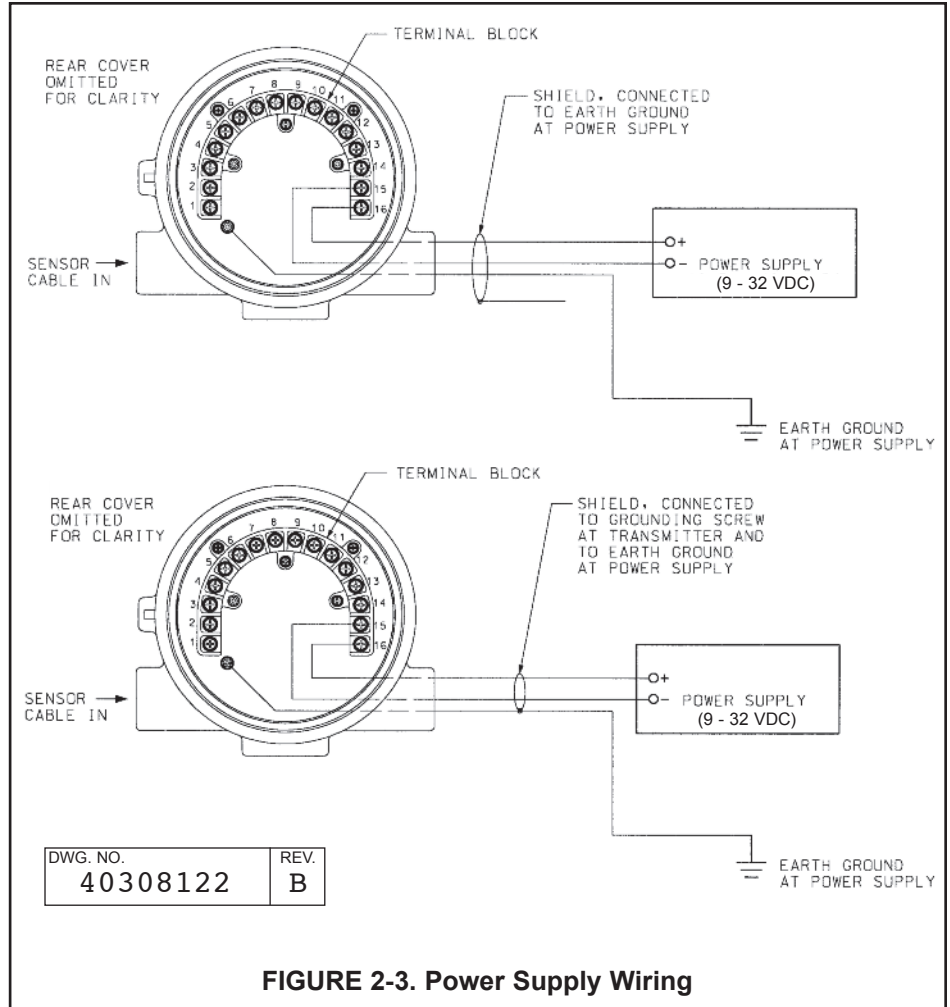

FIGURE 2-3. Power Supply Wiring

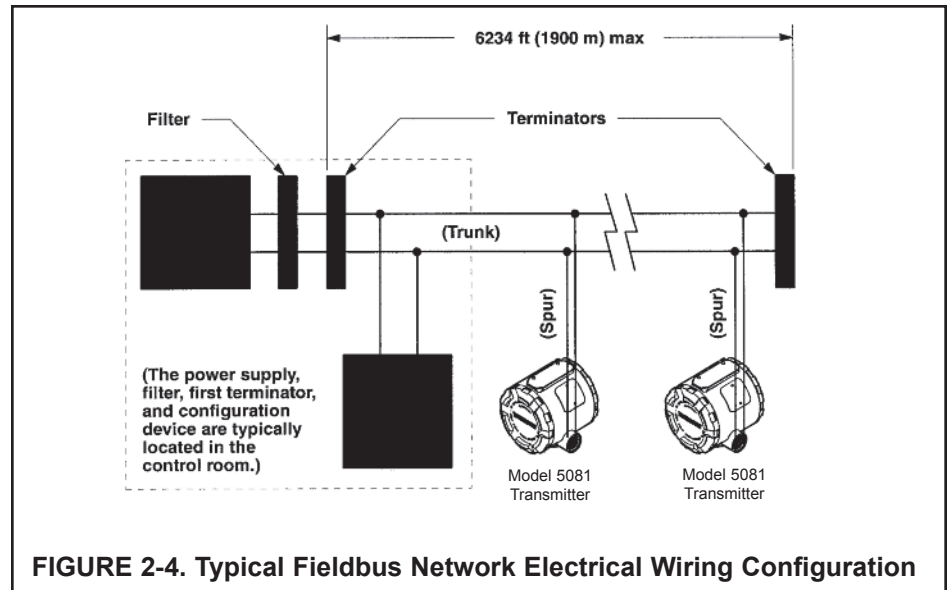

FIGURE 2-4. Typical Fieldbus Network Electrical Wiring Configuration

SECTION 3.0 SENSOR WIRING

- 3.1 Wiring Model 499A oxygen, chlorine, and ozone sensors
- 3.2 Wiring Model 499ACL-01 (free chlorine) and pH sensors
- 3.3 Wiring Model Hx438 and Gx448 sensors

NOTE

The Model 5081-A transmitter leaves the factory configured for use with the Model 499ADO sensor (ppm dissolved oxygen). If a 499ADO sensor is not being used, turn to Section 7.5.3 and configure the transmitter for the desired measurement (ppb oxygen, oxygen measured using a steam-sterilizable sensor, free chlorine, total chlorine, or ozone) before wiring the sensor to the transmitter. Operating the transmitter and sensor for longer than five minutes while the transmitter is improperly configured will greatly increase the stabilization time for the sensor.

Be sure to turn off power to the transmitter before wiring the sensor.

3.1 WIRING MODEL 499A OXYGEN, CHLORINE, AND OZONE SENSORS

All 499A sensors (499ADO, 499ATrDO, 499ACL-01, 499ACL-02, and 499AOZ) have identical wiring.

Use the pigtail wire and wire nuts provided with the sensor when more than one wire must be attached to a single terminal.

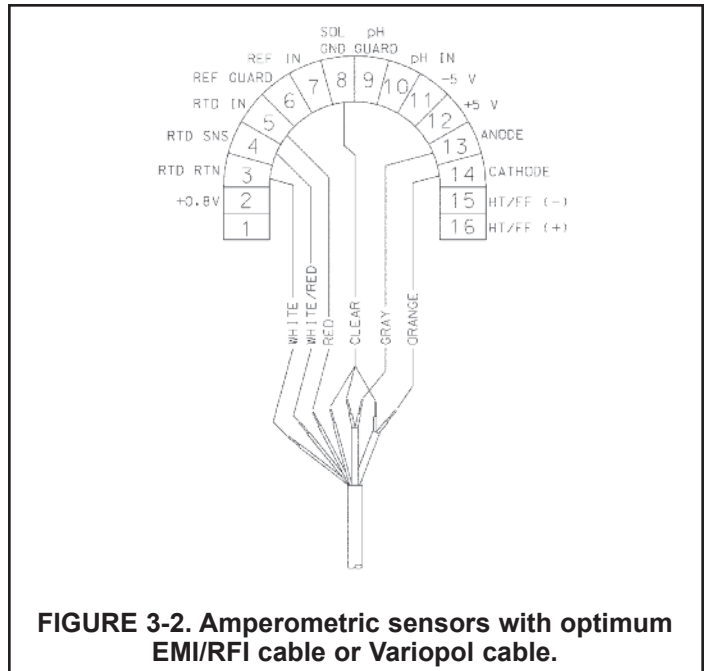
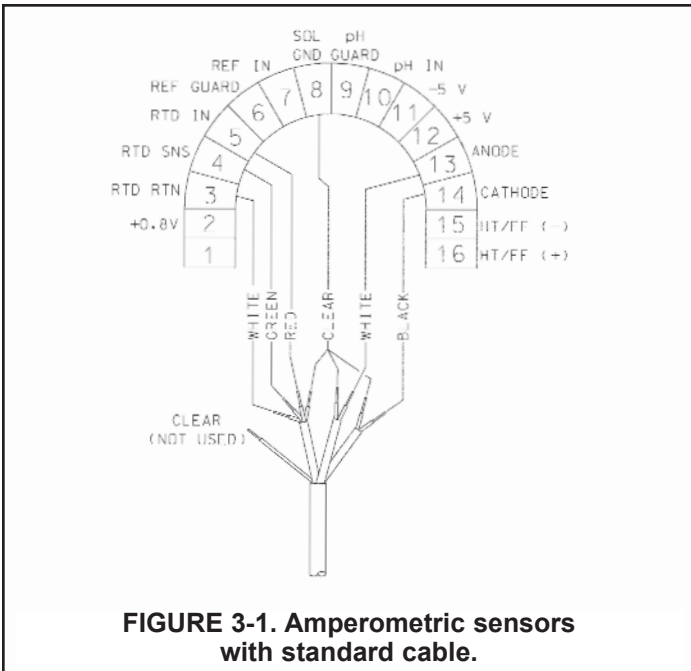

3.2 WIRING MODEL 499ACL-01 (Free Chlorine) SENSORS AND pH SENSORS

If free chlorine is being measured and the pH of the liquid varies more than 0.2 pH unit, a continuous correction for pH **must** be applied to the chlorine reading. Therefore, a pH sensor must be wired to the transmitter. This section gives wiring diagrams for the pH sensors typically used.

When using the 499ACL-01 (free chlorine) sensor with a pH sensor, use the RTD in the pH sensor for measuring temperature. DO NOT use the RTD in the chlorine sensor.

The pH sensor RTD is needed for temperature measurement during buffer calibration. During normal operation, the RTD in the pH sensor provides the temperature measurement required for the free chlorine membrane permeability correction.

Refer to the table to select the appropriate wiring diagram. Most of the wiring diagrams require that two or more shield wires be attached to a single terminal. Use the pigtail wire and wire nuts provided with the chlorine sensor to make the connection. **Insulate and tape back unused wires.**

Free chlorine sensor cable	pH sensor	Figure
Standard	399VP-09	3-3
Standard	399-14	3-4
Standard	399-09-62	3-5
EMI/RFI or Variopol	399VP-09	3-6
EMI/RFI or Variopol	399-14	3-7
EMI/RFI or Variopol	399-09-62	3-8

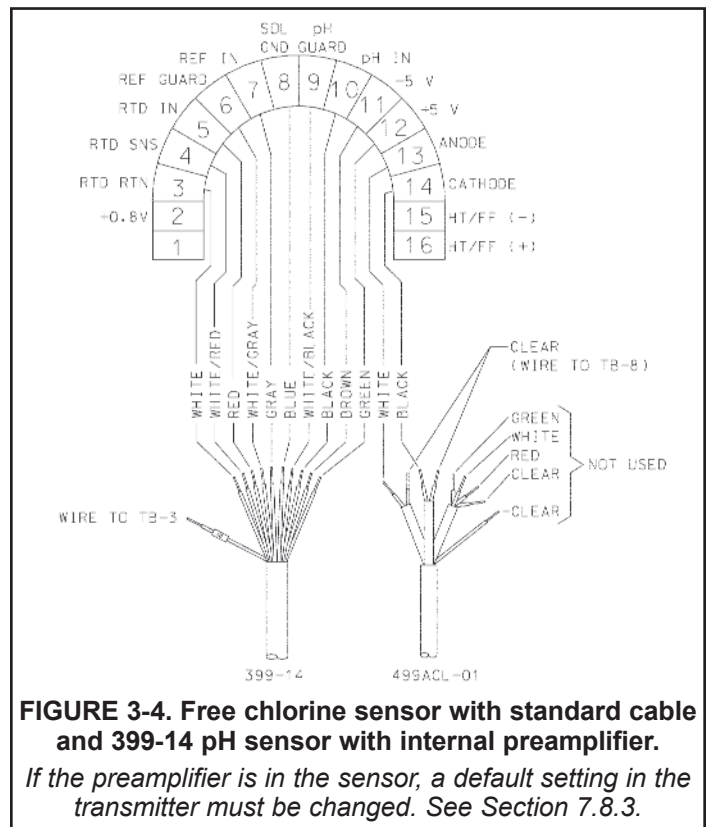
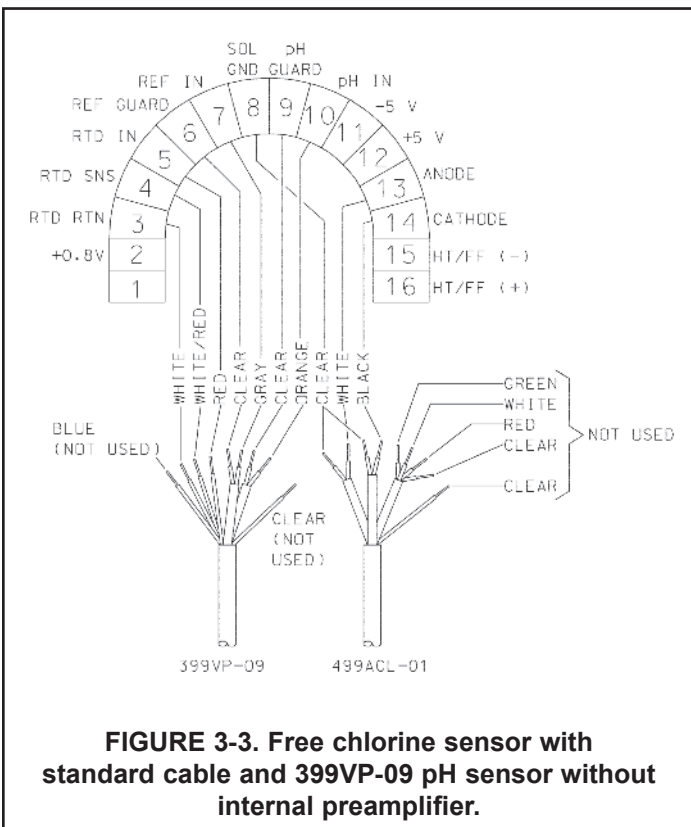

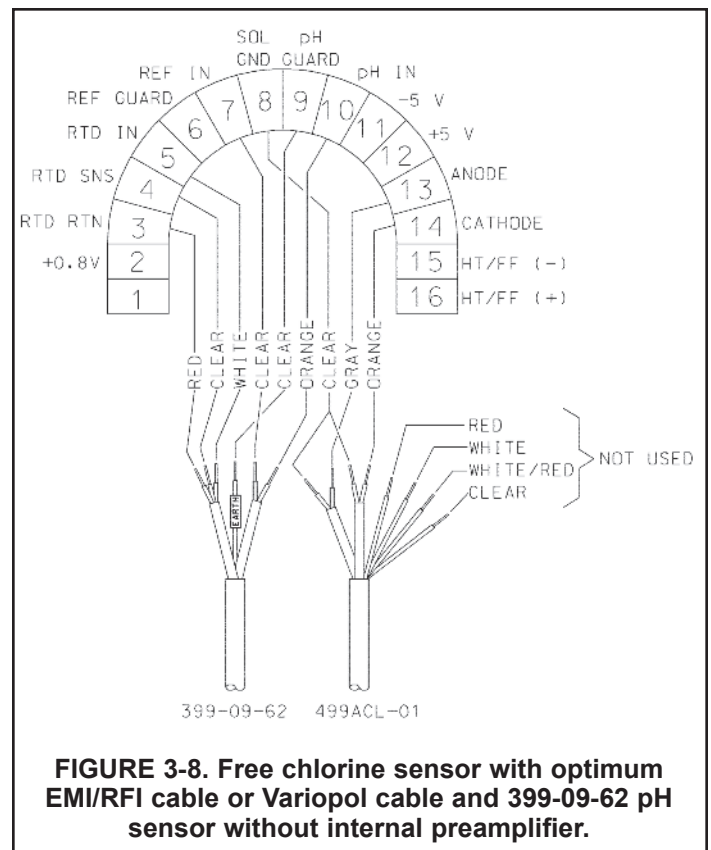
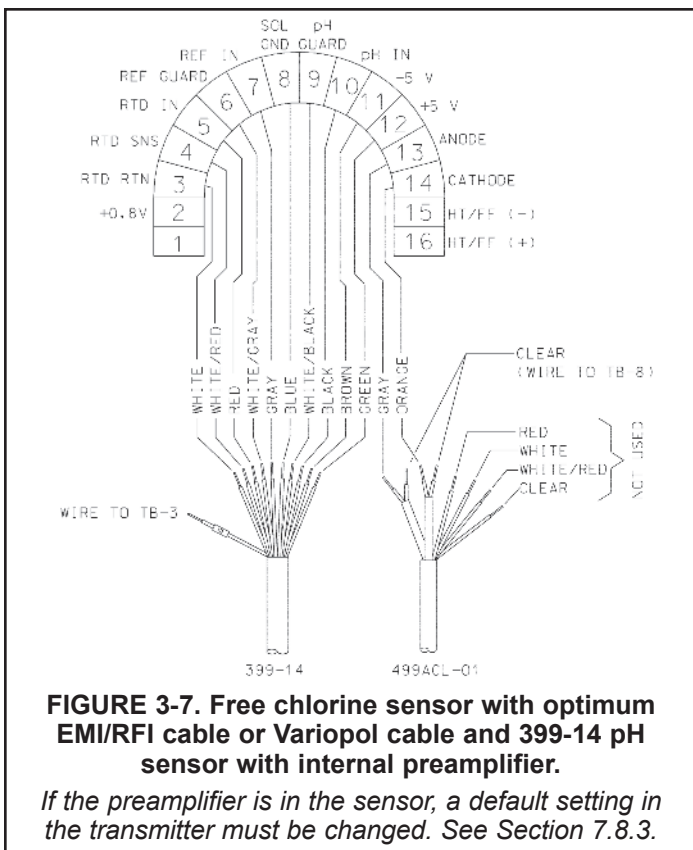
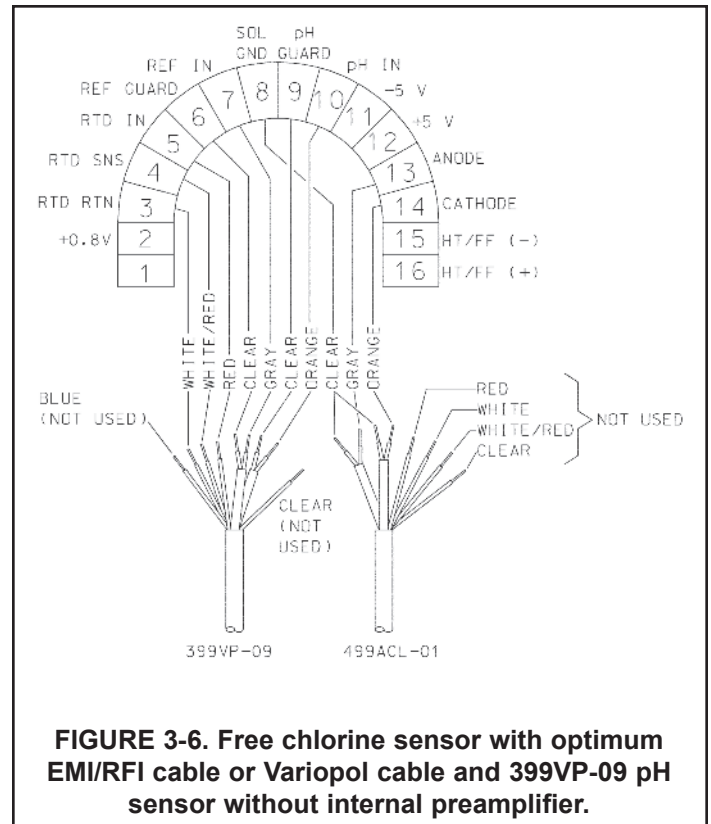
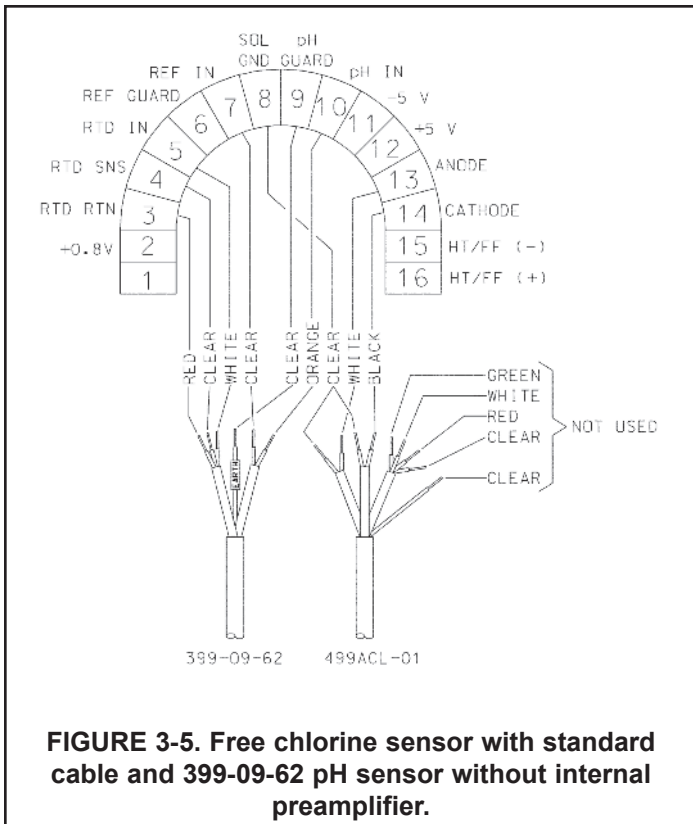

3.3 WIRING Hx438 AND Gx448 SENSORS

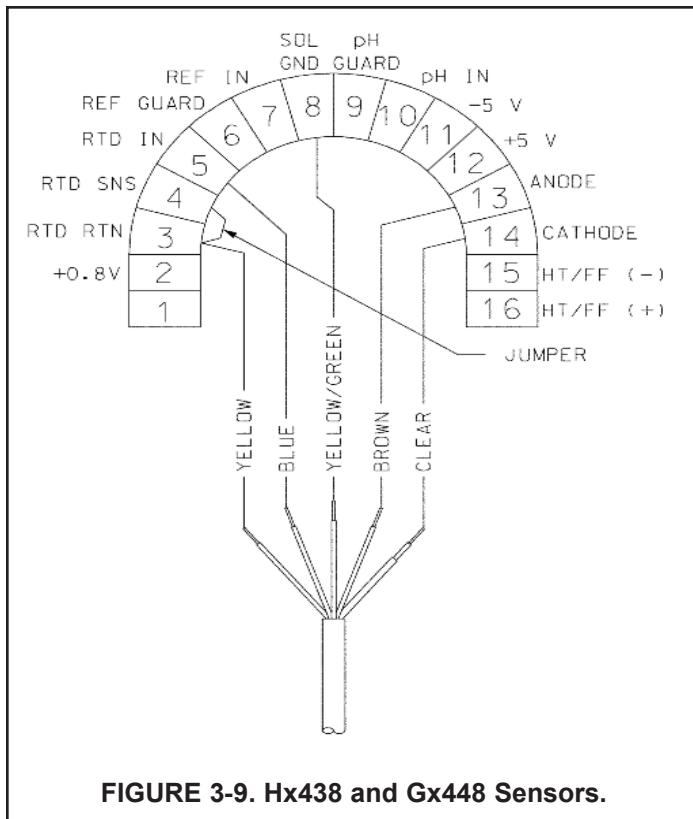

FIGURE 3-9. Hx438 and Gx448 Sensors.

SECTION 4.0 INTRINSICALLY SAFE & EXPLOSION PROOF INSTALLATIONS

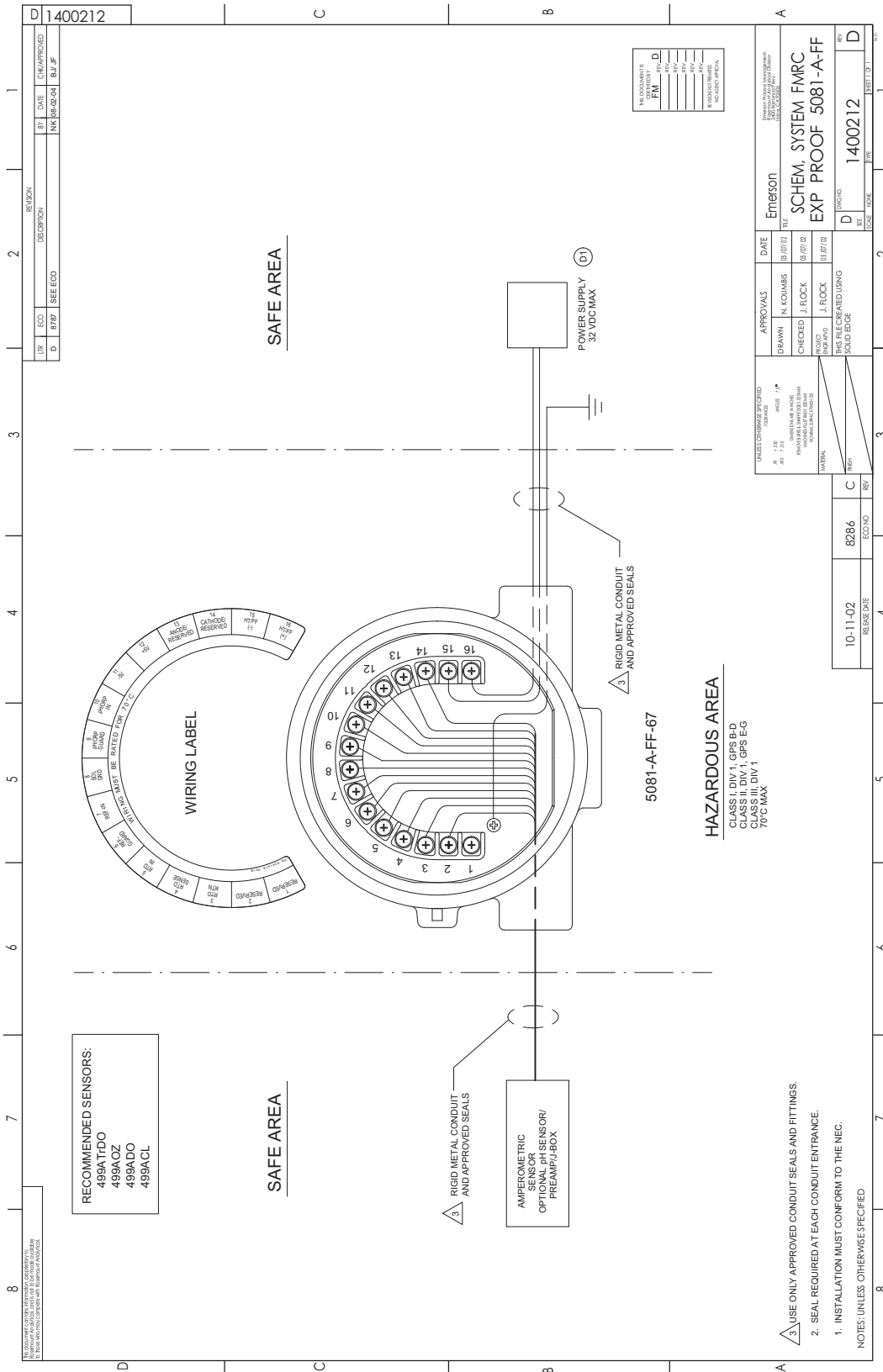

FIGURE 4-1. FMRC Explosion-Proof Installation

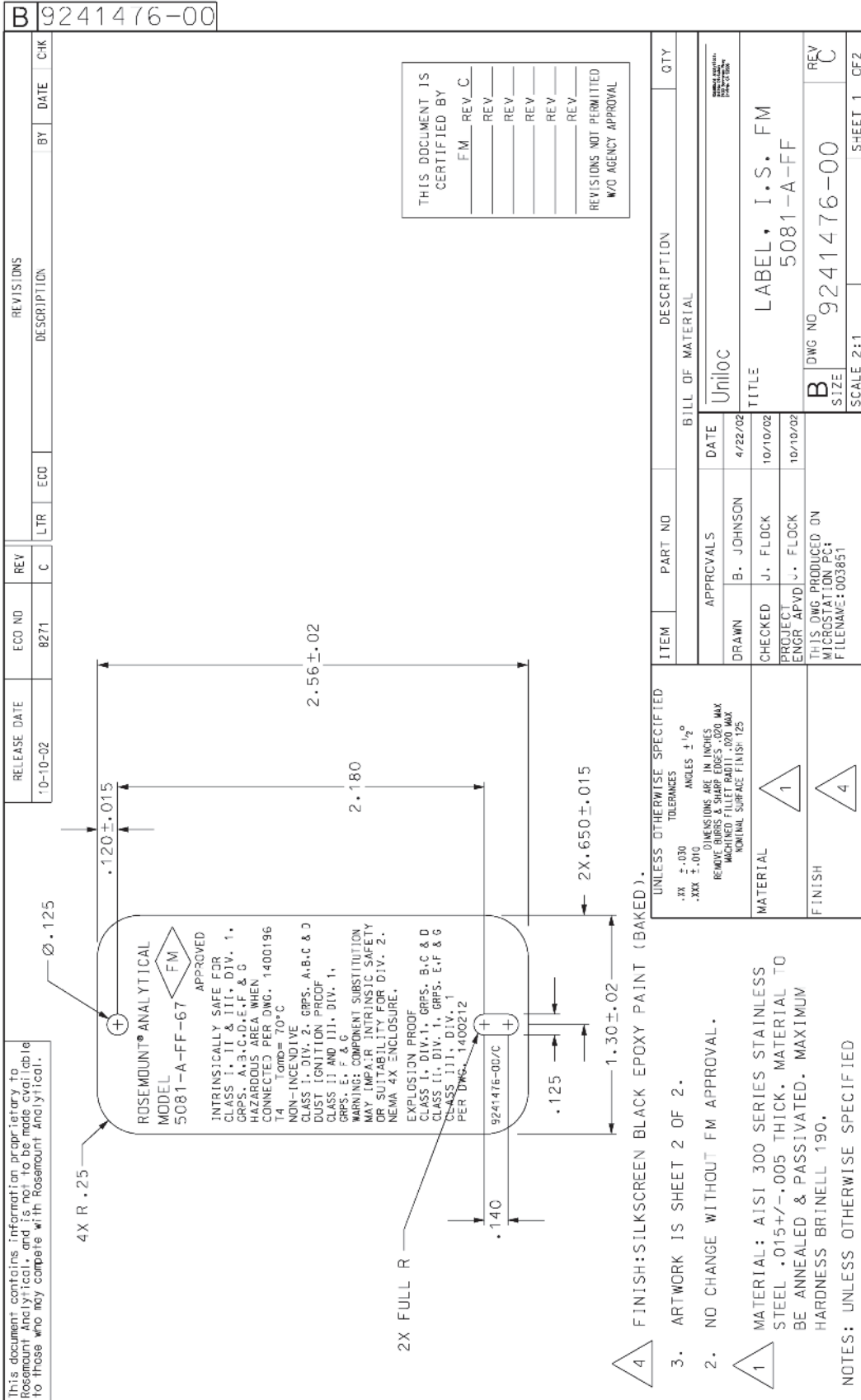

FIGURE 4-2. FM Intrinsically-Safe Installation Label

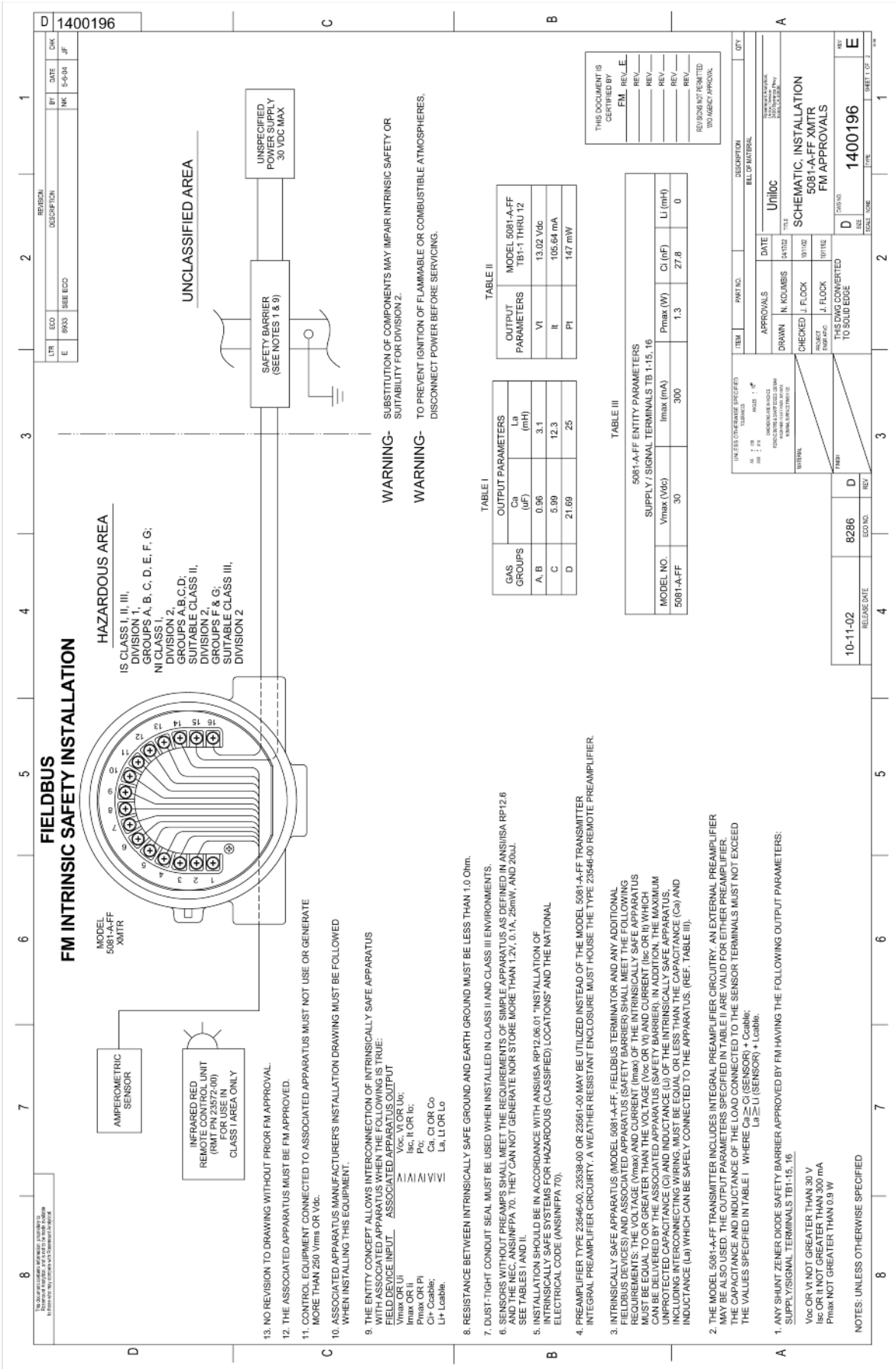

FIGURE 4-3. FM Intrinsically-Safe Installation (1 of 2).

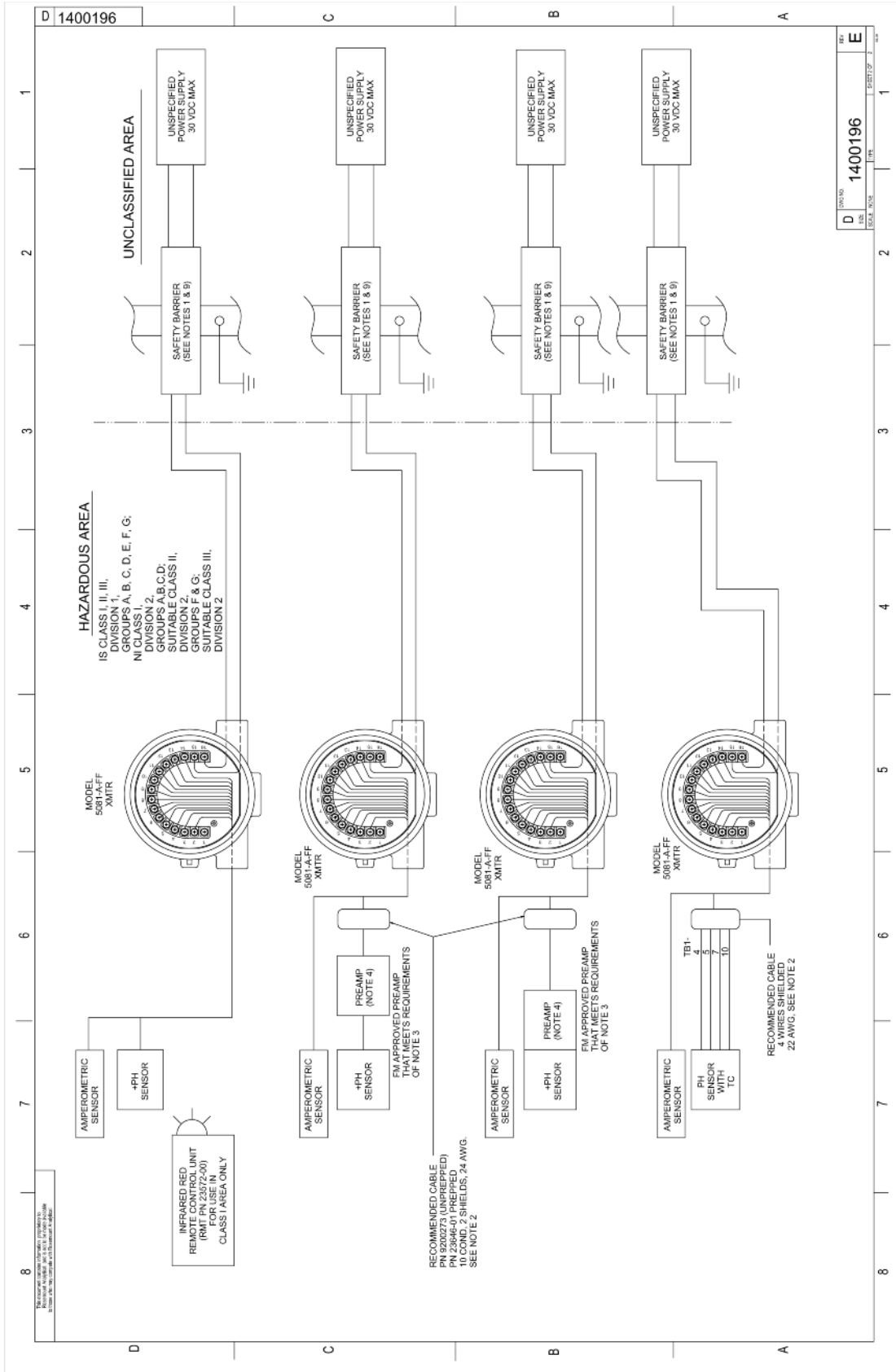

FIGURE 4-3. FM Intrinsically-Safe Installation (2 of 2).

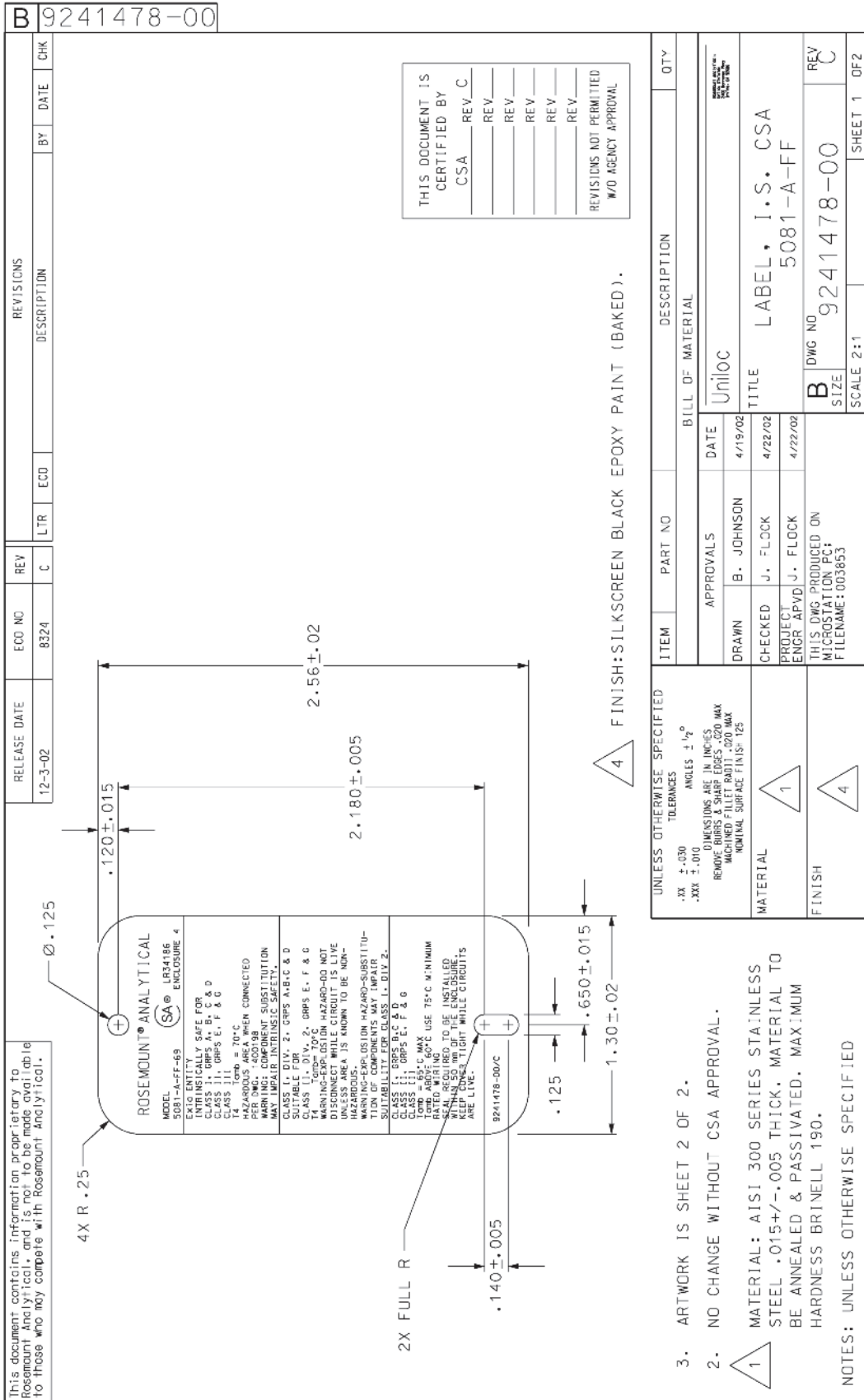

FIGURE 4-4. CSA Intrinsically-Safe Installation Label

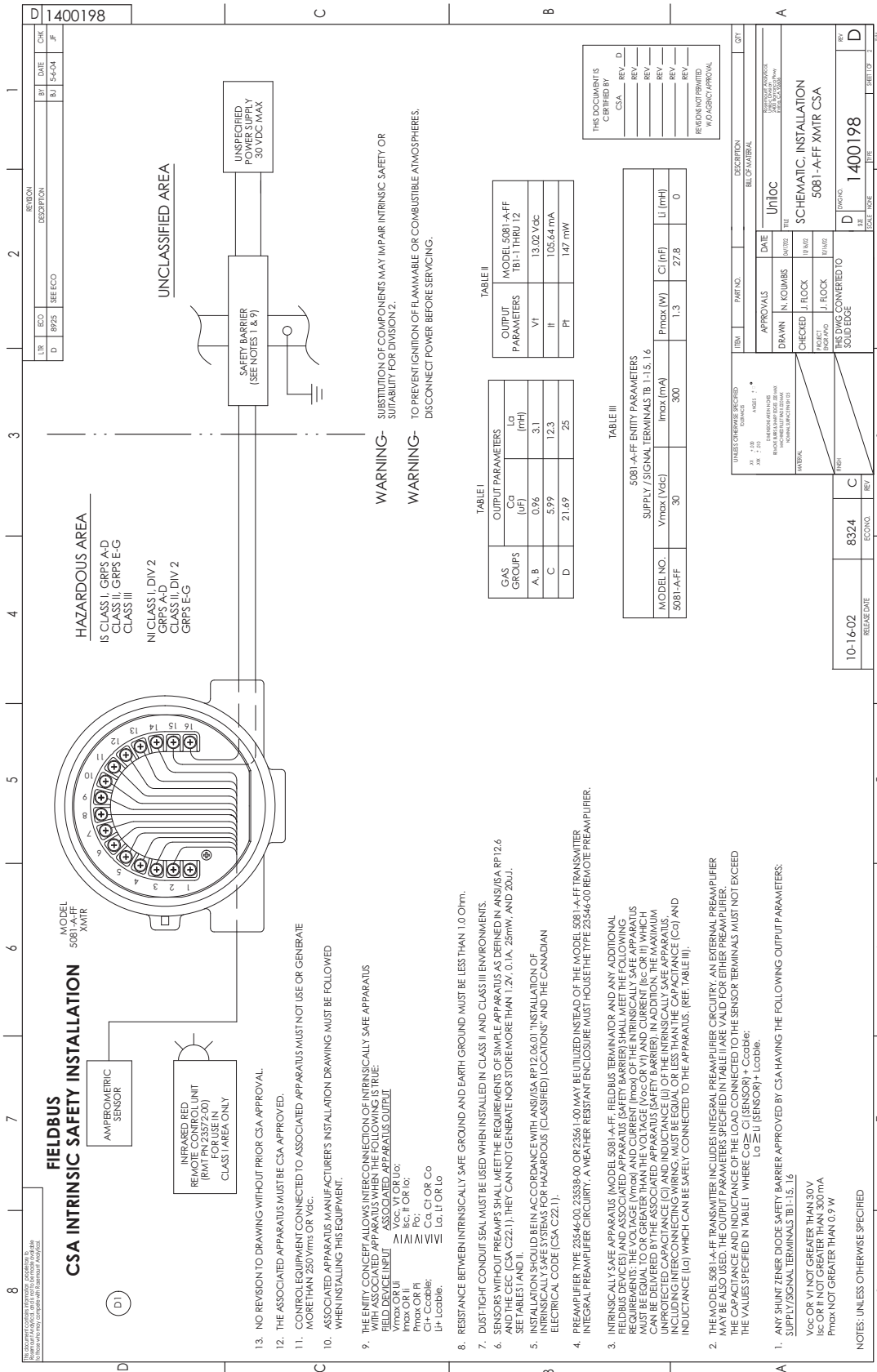

FIGURE 4-5. CSA Intrinsically-Safe Installation (1 of 2)

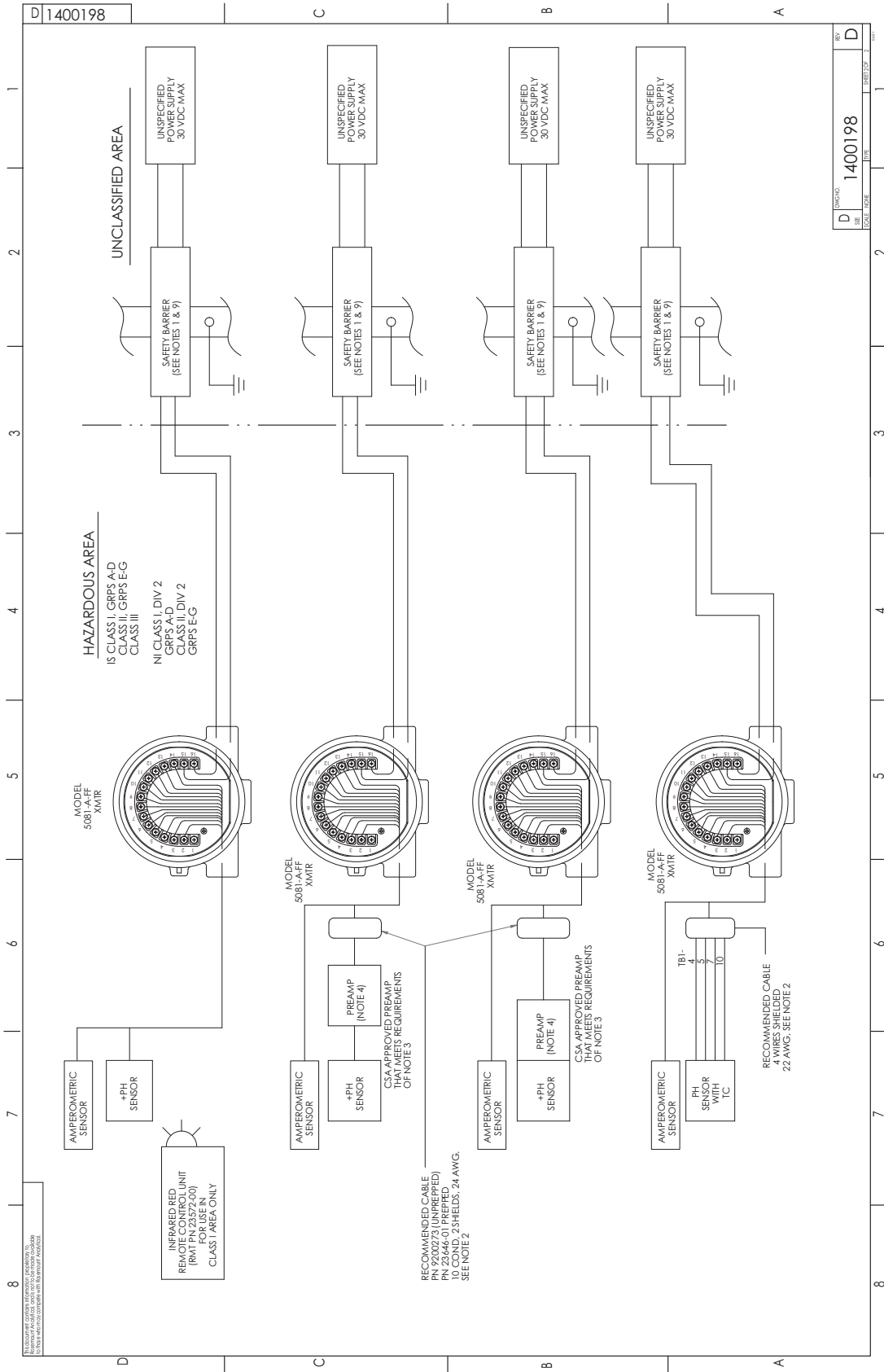

FIGURE 4-5. CSA Intrinsically-Safe Installation (2 of 2)

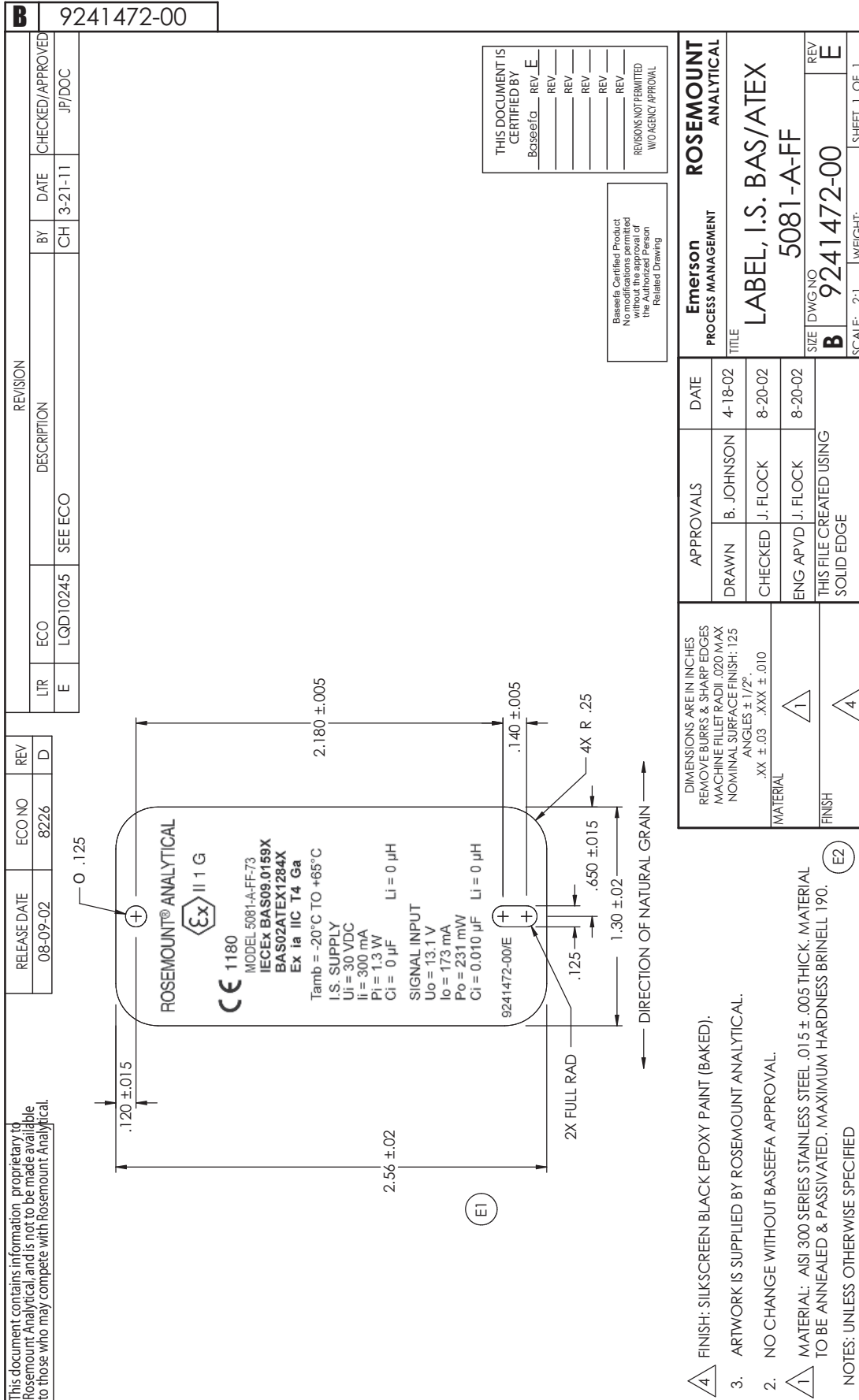

FIGURE 4-6. BASEEFA/ATEX Intrinsically-Safe Installation Label

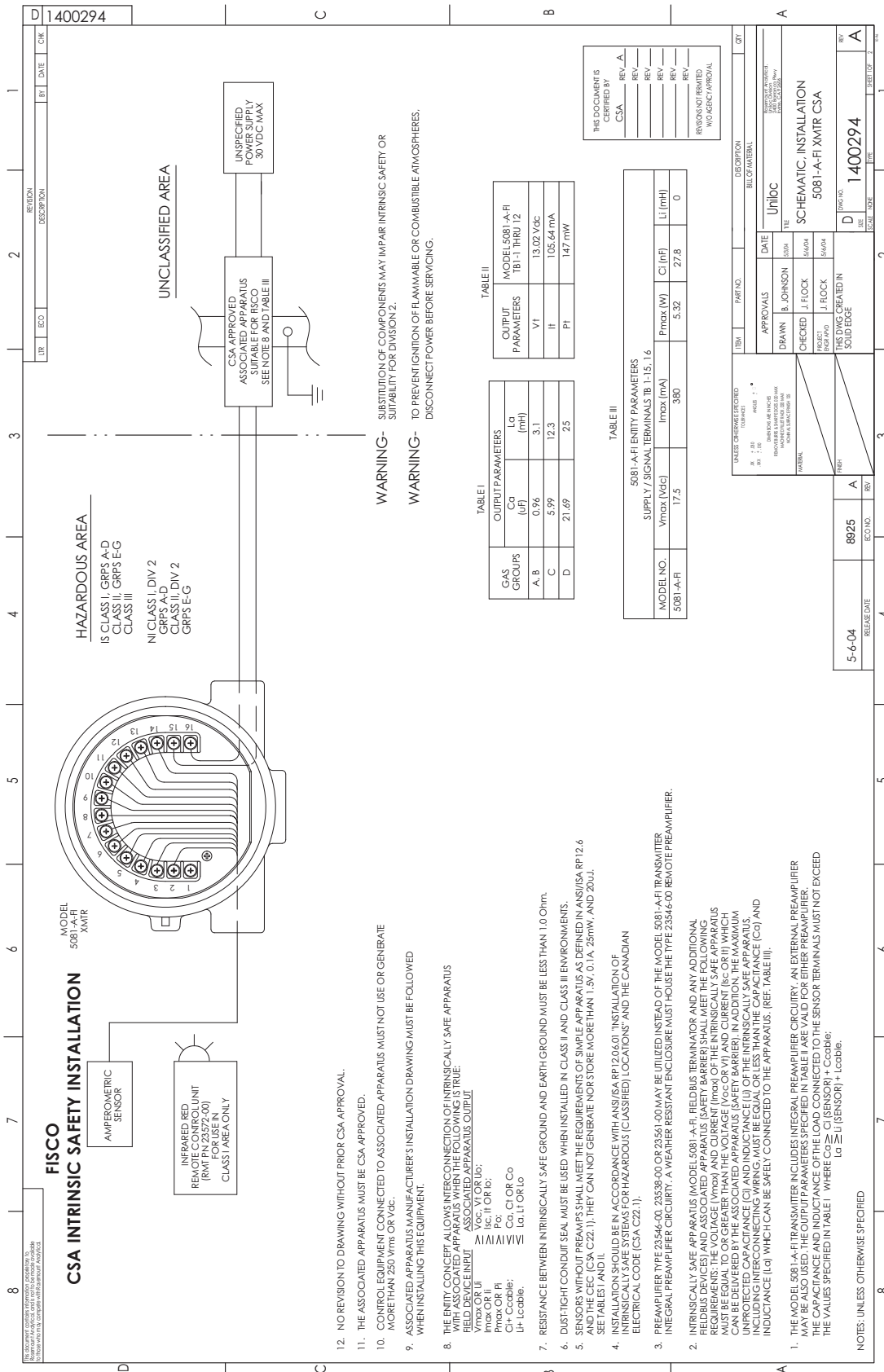

FIGURE 4-7. CSA Intrinsicly-Safe Installation (1 of 2)

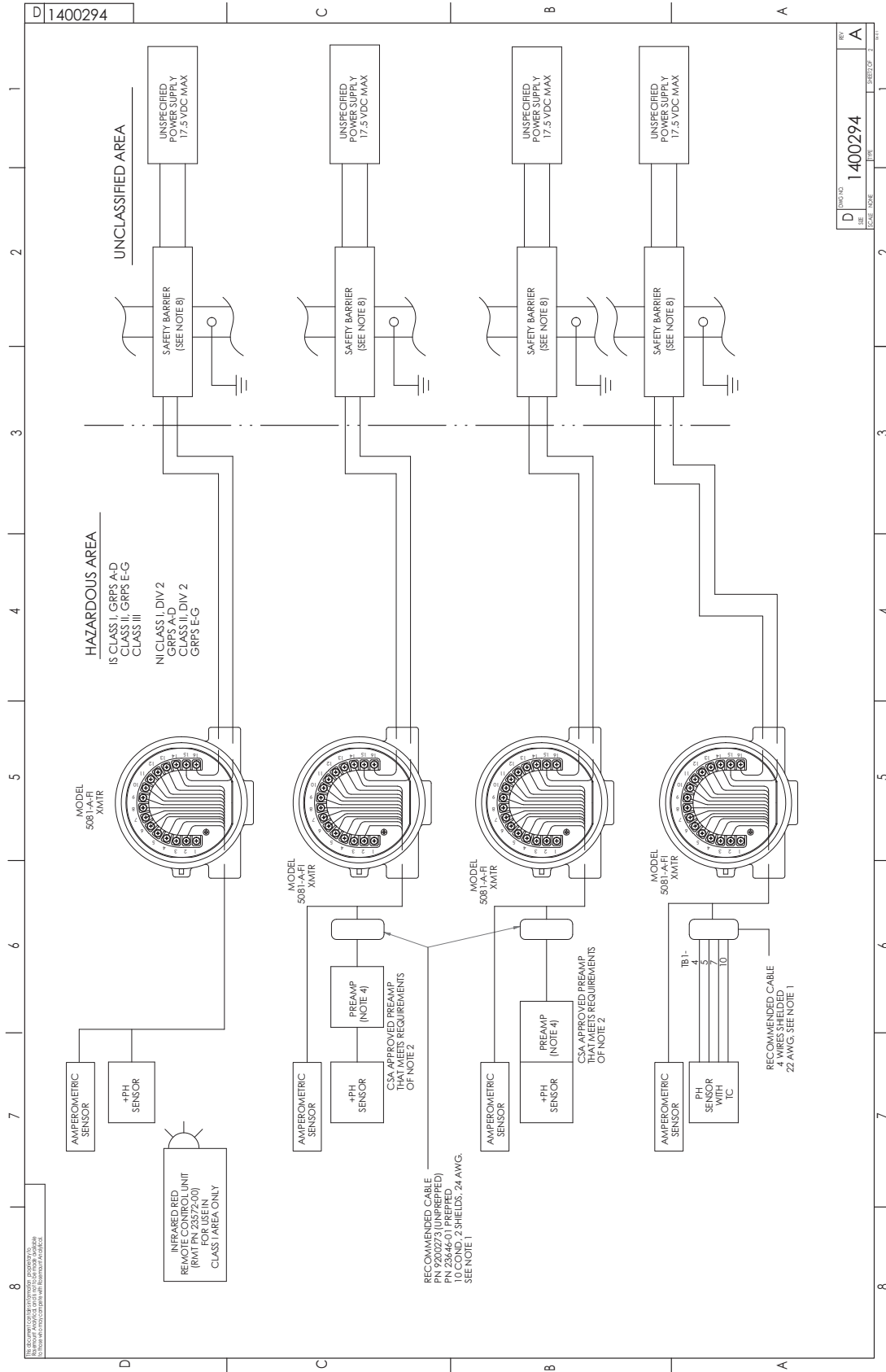

FIGURE 4-8. CSA Intrinsically-Safe Installation (2 of 2)

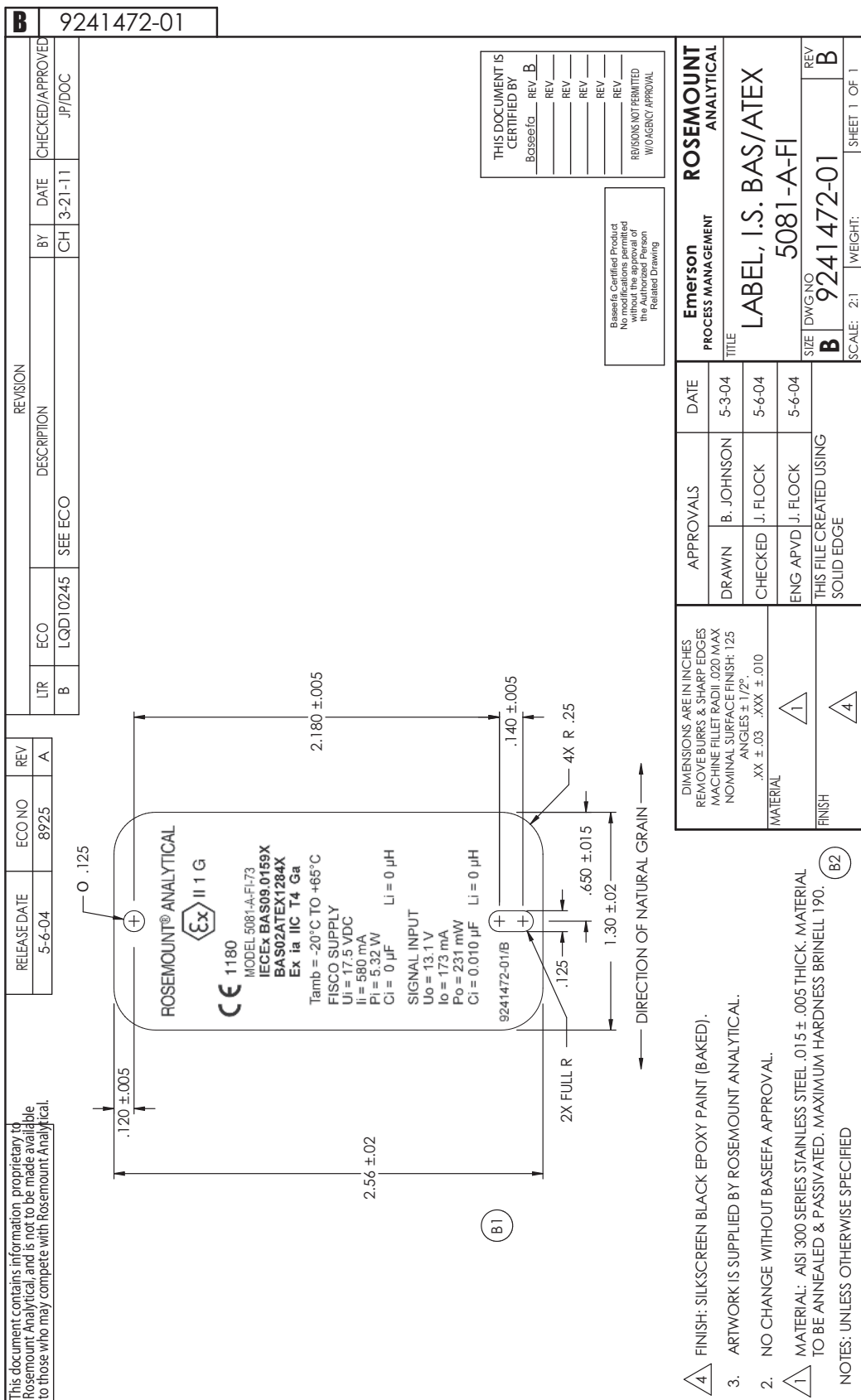

FIGURE 4-9. BAS/ATEX Intrinsically-Safe Label 5081-A-FI

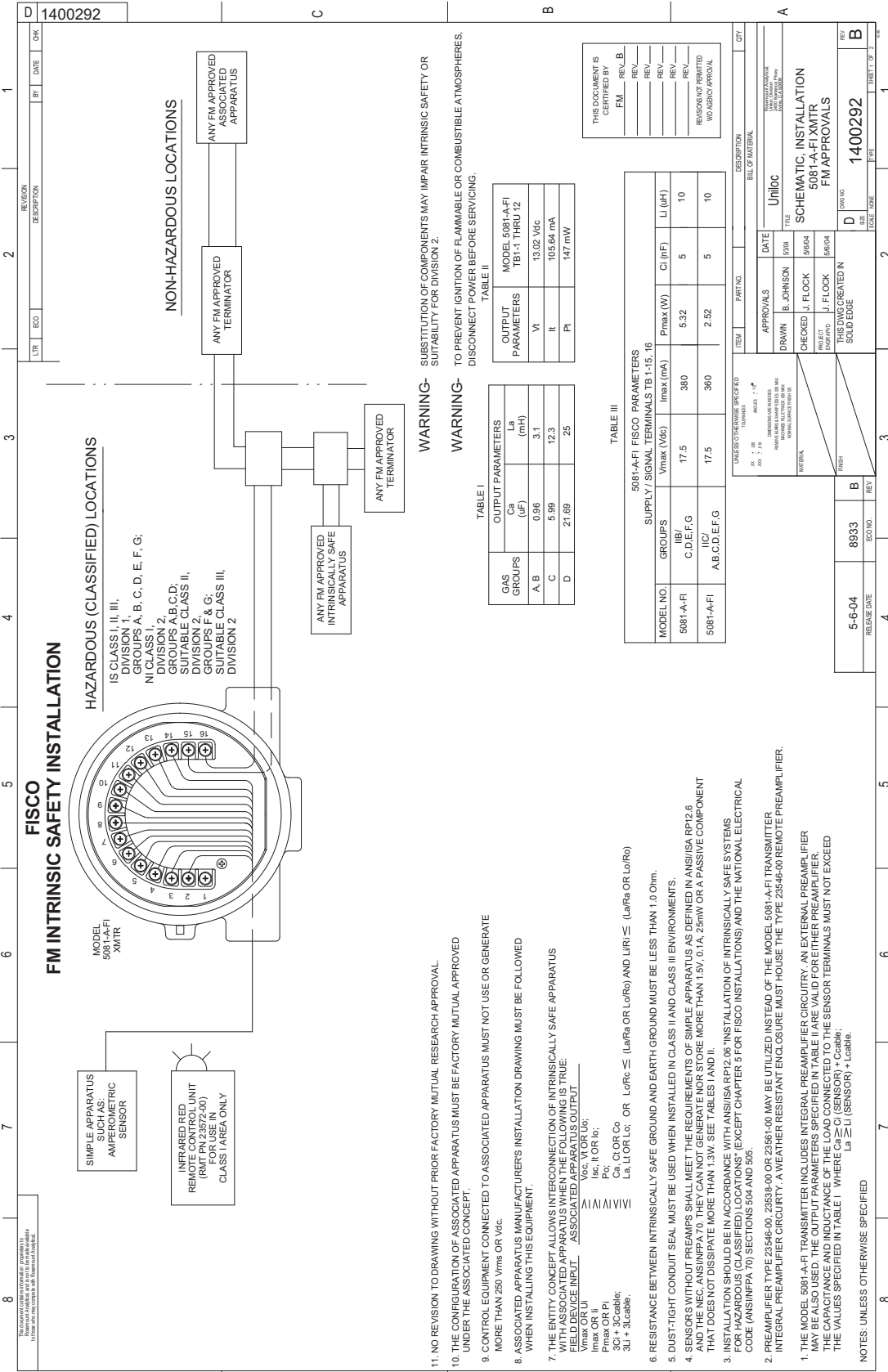

FIGURE 4-10. FM Intrinsically-Safe Installation 5081-A-FI (1 of 2)

REV	ECO	DESCRIPTION	DATE	CHK
1				
2				
3				
4				
5				
6				
7				
8				

D 1400292

REV	DATE	DESCRIPTION
1		
2		
3		
4		
5		
6		
7		
8		

ITEM	PART NO.	DESCRIPTION	QTY
1	UNILIOC	UNILIOC	1
2	5081-A-FI XMTR	5081-A-FI XMTR	1
3	FM APPROVALS	FM APPROVALS	1

APPROVALS: DRAWN B. JOHNSON, DATE 5/3/04, CHECKED J. FLOCK, DATE 5/8/04, PROJECT J. FLOCK, DATE 5/8/04, THIS DOCUMENT CREATED IN SOLID EDGE D 1400292

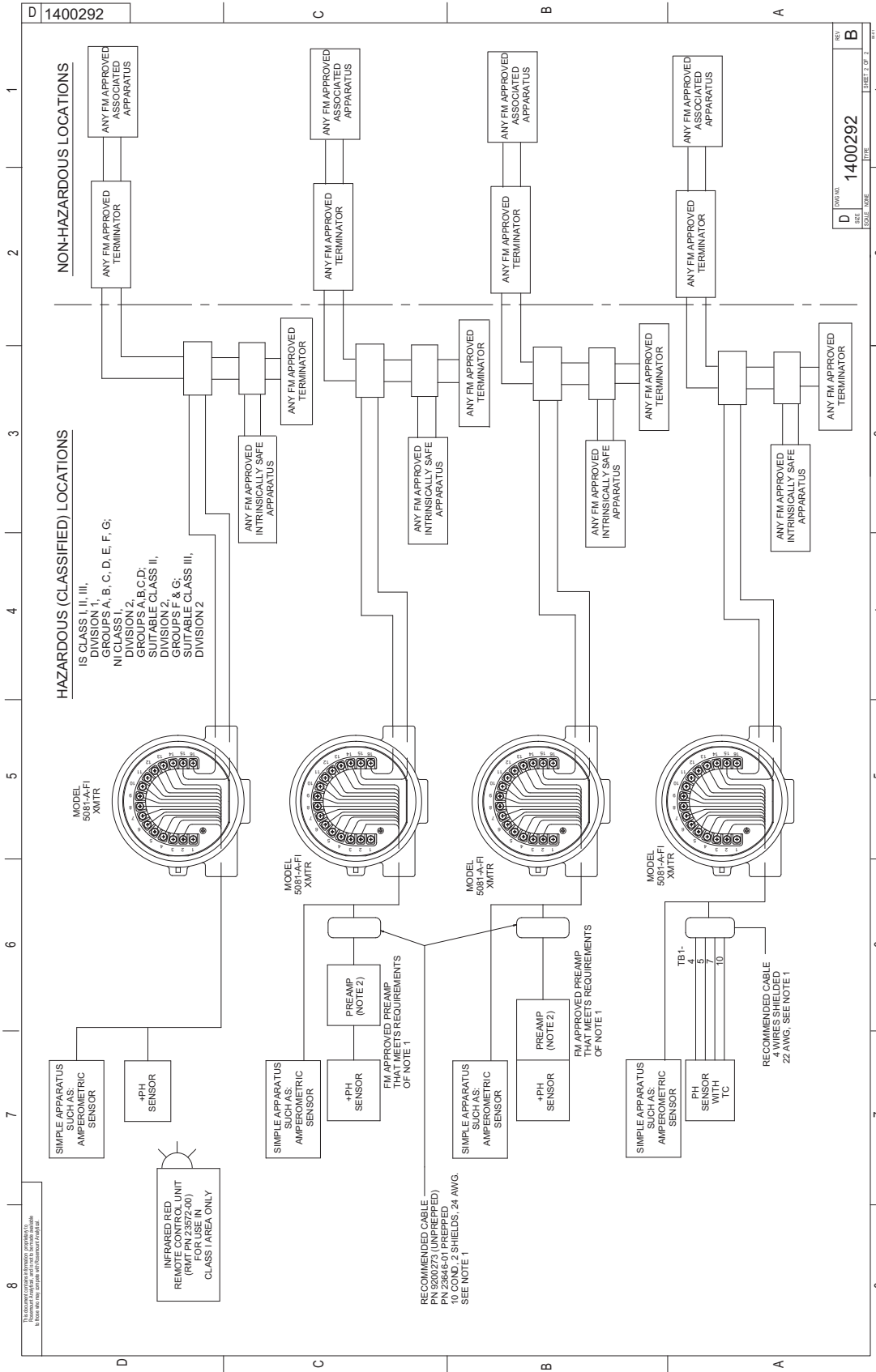

FIGURE 4-10. FM Intrinsically-Safe Installation 5081-A-FI (2 of 2)

SECTION 5.0 DISPLAY AND OPERATION WITH INFRARED REMOTE CONTROLLER

- 5.1 Display Screens
- 5.2 Infrared Remote Controller (IRC) - Key Functions
- 5.3 Menu Tree
- 5.4 Diagnostic Messages
- 5.5 Security
- 5.6 Using Hold

5.1 DISPLAY SCREENS

Figure 5-1 shows the process display screen. Figure 5-2 shows the program display screen.

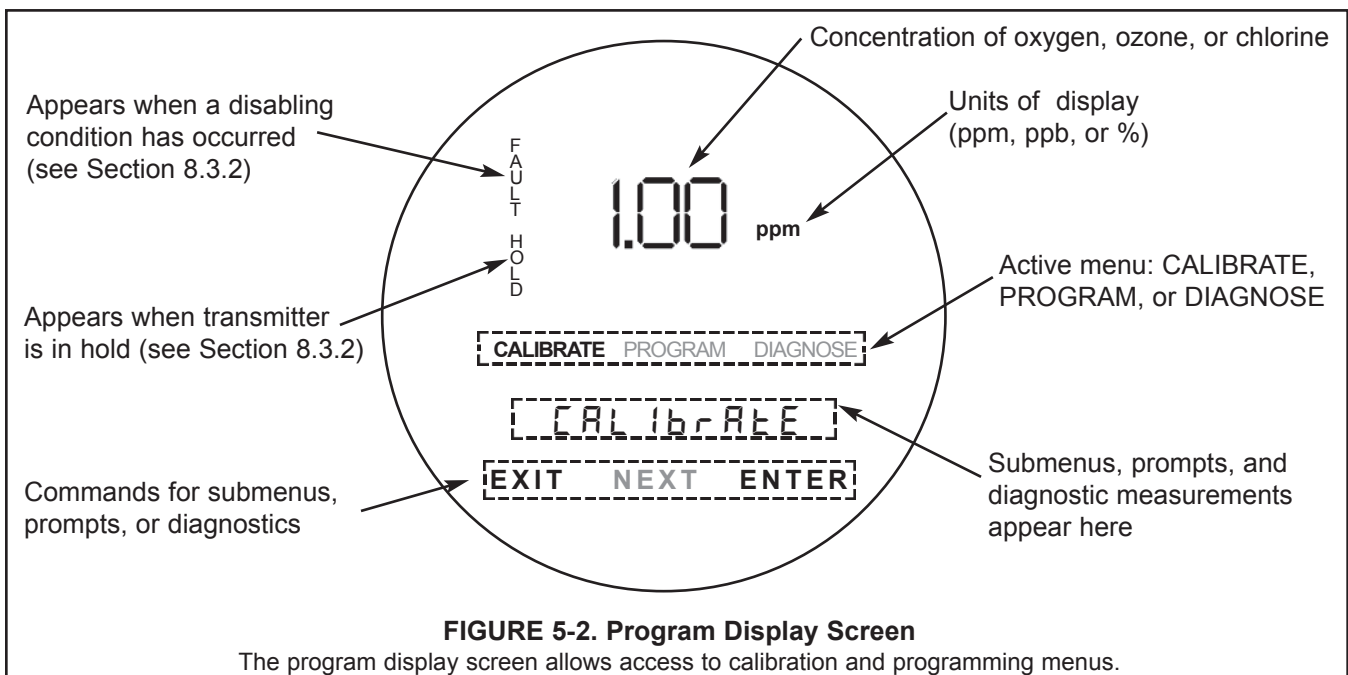
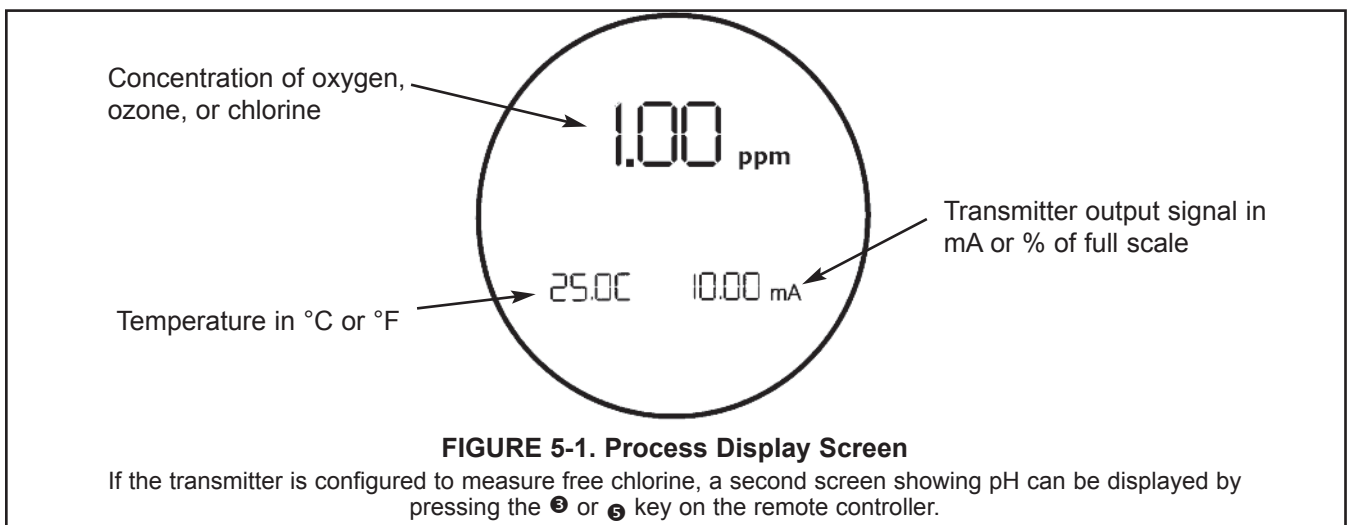

5.2 INFRARED REMOTE CONTROLLER (IRC) - KEY FUNCTIONS

The infrared remote controller is used to calibrate and program the transmitter and to display diagnostic messages. See Figure 5-3 for a description of the function of the keys.

Hold the IRC within 6 feet of the transmitter, and not more than 15 degrees from the center of the display window.

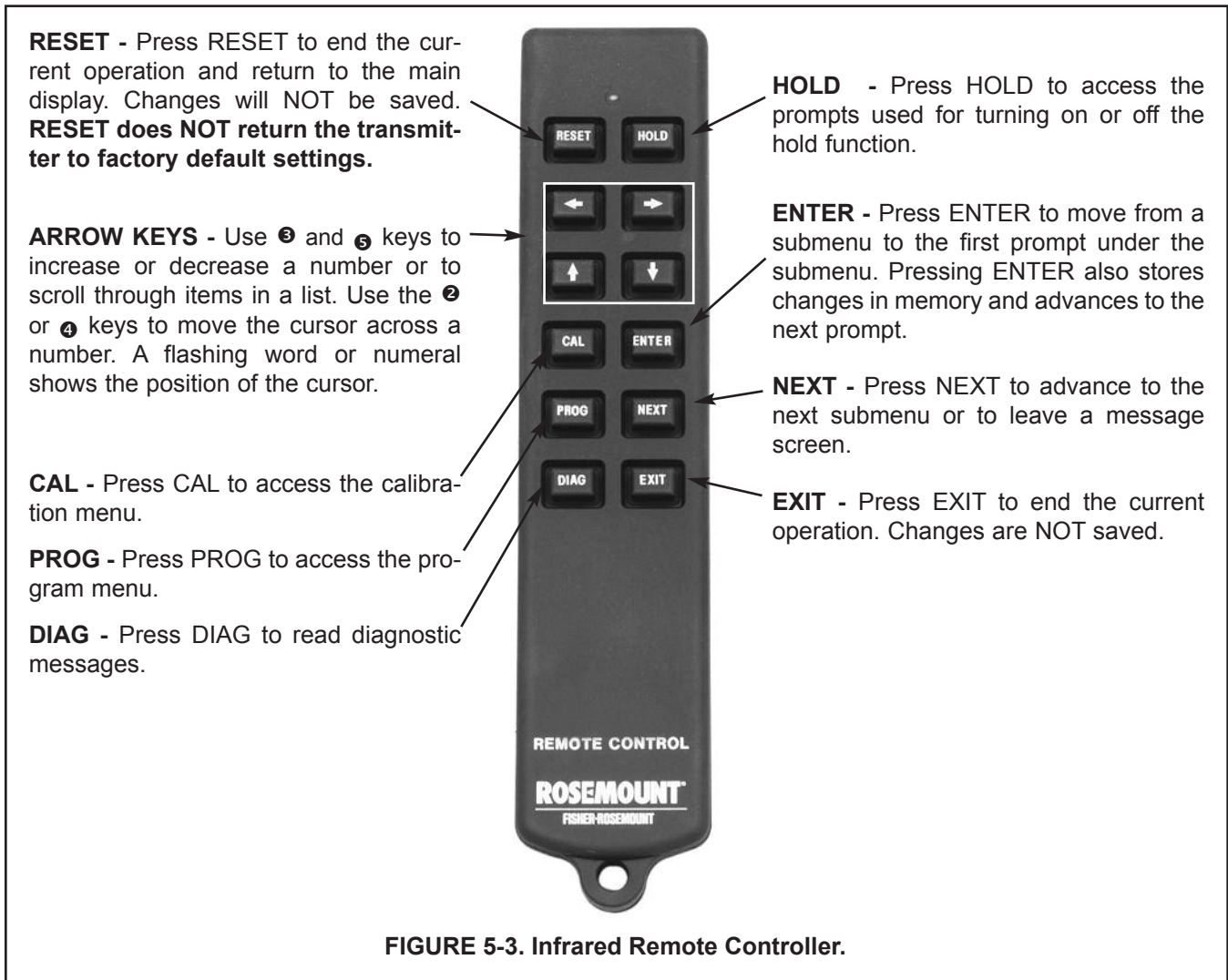

5.3 MENU TREE

The Model 5081-A transmitter has three menus: CALIBRATE, PROGRAM, and DIAGNOSE. Under the Calibrate and Program menus are several submenus. Under each submenu are a number of prompts. The DIAGNOSE menu shows the reader diagnostic variables that are useful in troubleshooting. Figure 5-4, on the following page, shows the complete menu tree.

5.4 DIAGNOSTIC MESSAGES

Whenever a warning or fault limit has been exceeded, the transmitter displays diagnostic fault messages. The display alternates between the main display and the diagnostic message. See Section 15.0 for the meaning of fault and warning messages.

5.5 SECURITY

5.5.1 Purpose. Use the security code to prevent program settings and calibrations from accidentally being changed. To program a security code, refer to Section 7.5.

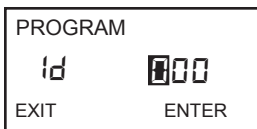

1. If settings are protected with a security code, pressing PROG or CAL on the remote controller causes the **Id** screen to appear.
2. Use the arrow keys to enter the security code. Press ENTER.
3. If the security code is correct, the first submenu appears. If the code is incorrect, the process display reappears.
4. To retrieve a forgotten code number, enter 555 at the **Id** prompt. The present security code will appear.

5.5.2 Change security code using Fieldbus.

Access: DeltaV Explorer/Transducer Block/Properties Identification Tab

Parameter: Security Code for Infrared Remote (LOCAL_OPERATOR_INTERFACE_TAG)

Enter desired security code (0 - 999)

5.6 USING HOLD

During calibration, the sensor may be exposed to solutions having concentration outside the normal range of the process. To prevent false alarms and undesired operation of chemical dosing pumps, place the transmitter in hold during calibration. Activating hold keeps the transmitter output at the last value or sends the output to a previously determined value. See Section 7.3, Output Ranging, for details.

After calibration, reinstall the sensor in the process stream. Wait until readings have stabilized before deactivating Hold.

To activate or deactivate Hold:

1. Press **HOLD** on the remote controller.
2. The **HoLd** prompt appears in the display. Press **⏪** or **⏩** to toggle Hold between **On** and **OFF**.
3. Press **ENTER** to save.

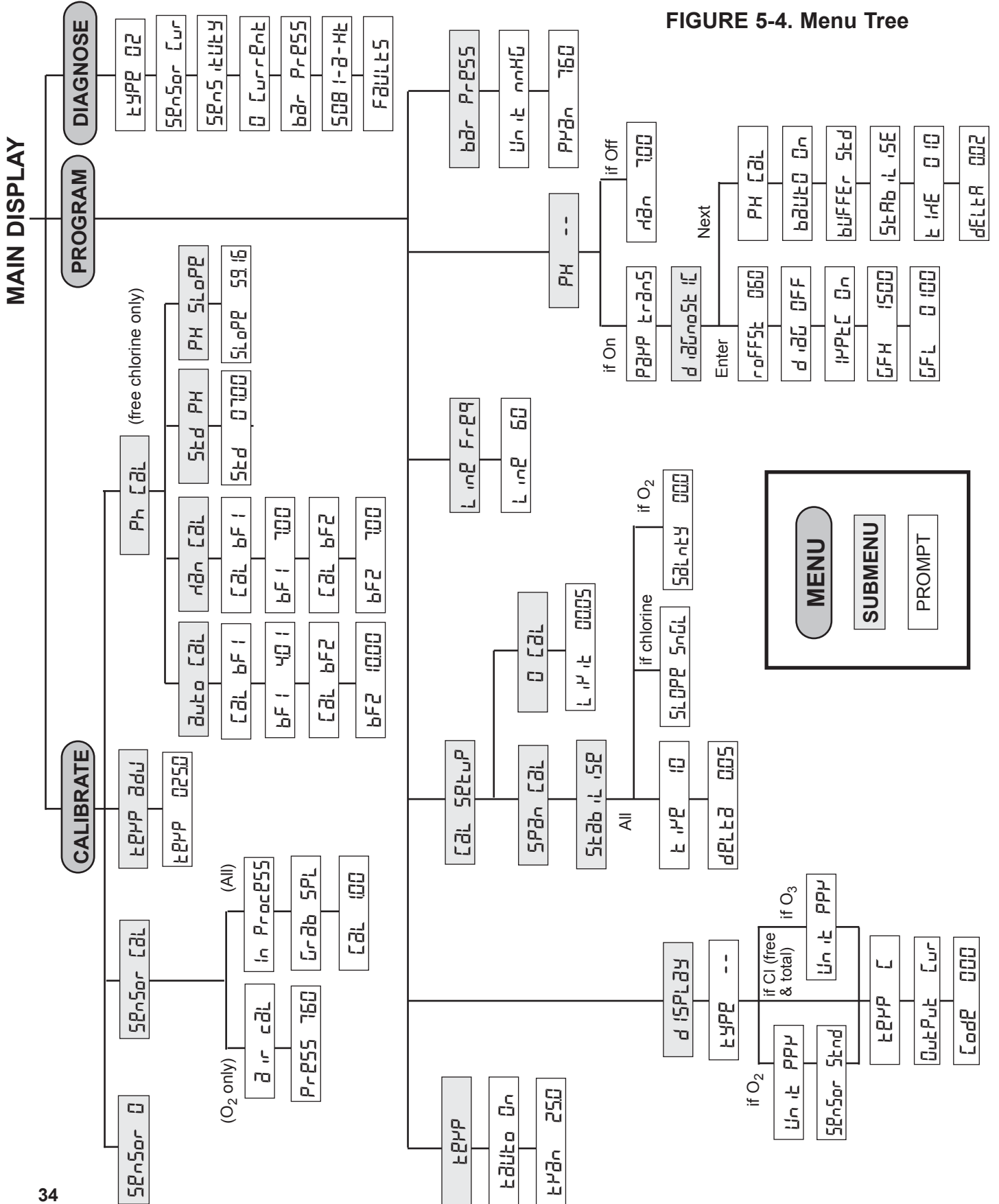

FIGURE 5-4. Menu Tree

SECTION 6.0

Operation with FOUNDATION Fieldbus and the DeltaV Control System

6.1 OVERVIEW

This section covers basic transmitter operation and software functionality. For detailed descriptions of the function blocks common to all Fieldbus devices, refer to Fisher-Rosemount Fieldbus FOUNDATION Function Blocks manual, publication number 00809-4783.

Figure 6-1 illustrates how the conductivity signal is channeled through the transmitter to the control room and the FOUNDATION Fieldbus configuration device.

Software Functionality. The Model 5081-A software is designed to permit remote testing and configuration of the transmitter using the Fisher-Rosemount DeltaV Control System, or other FOUNDATION fieldbus compliant host.

Transducer Block. The transducer block contains the actual measurement data. It includes information about sensor type, engineering units, reranging, damping, temperature compensation, calibration, and diagnostics.

Resource Block. The resource Block contains physical device information, including available memory, manufacturer identification, type of device, and features.

FOUNDATION Fieldbus Function Blocks. The Model 5081-A includes four Analog Input (AI) function blocks and one PID Block as part of its standard offering.

Analog Input. The Analog Input (AI) block processes the measurement and makes it available to other function blocks. It also allows filtering, setting alarms, and changing engineering units.

PID Block. The PID Block receives a measurement from an AI block, performs PID control action, and makes the control signal available to an Analog Output (AO) block.

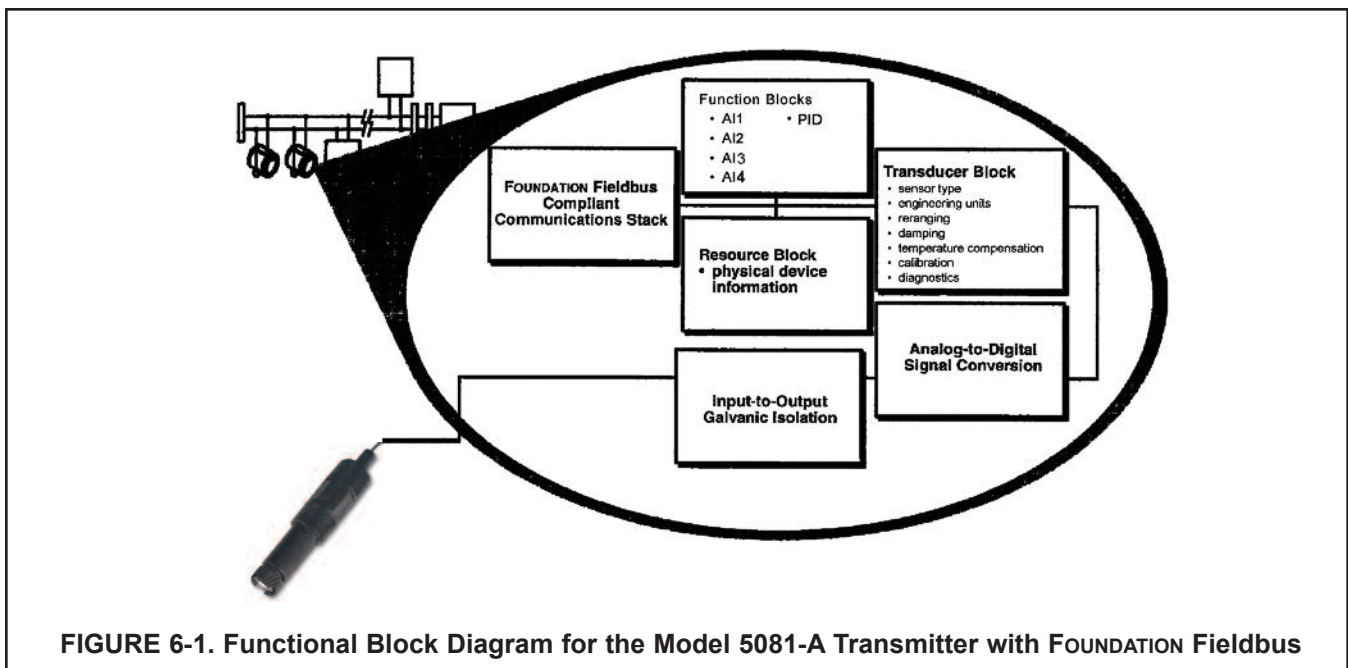

FIGURE 6-1. Functional Block Diagram for the Model 5081-A Transmitter with FOUNDATION Fieldbus

6.2 AI Block Configuration

The 5081A-FF has channels assignable to the measured value (oxygen, ozone, or chlorine), temperature, sensor current, and pH (free chlorine only). For proper operation, the AI Block must be assigned to the channel corresponding to the desired measurement, and the units in the XD_SCALE parameter of the AI Block must match the units of the measurement. Table 6-1, below, shows the channel assignments and units for each mode of the 5081A-FF.

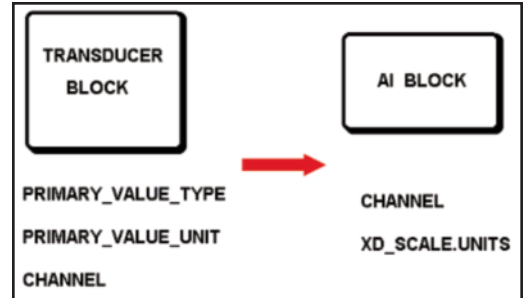

TABLE 6-1. Analog Input Block Configuration Values

5081A-FF TRANSDUCER BLOCK			AI BLOCK	
PRIMARY_VALUE_TYPE	CHANNEL	PRIMARY_VALUE_UNIT	CHANNEL	XD_SCALE.UNITS
Dissolved Oxygen (0xFF0)				
Dissolved Oxygen	1	ppm	1	ppm (1423)
		ppb	1	ppb (1424)
		%	1	% (1342)
Temperature	2	degree C	2	degree C (1001)
		degree F	2	degree F (1002)
Sensor Current	3	nA	3	nA (1213)
<hr/>				
Free Chlorine (0xFF1)				
Free Chlorine	1	ppm	1	ppm (1423)
Temperature	2	degree C	2	degree C (1001)
		degree F	2	degree F (1002)
Sensor Current	3	nA	3	nA (1213)
pH	4	pH	4	pH (1422)
<hr/>				
Ozone (0xFF3)				
Ozone	1	ppm	1	ppm (1423)
		ppb	1	ppb (1424)
Temperature	2	degree C	2	degree C (1001)
		degree F	2	degree F (1002)
Sensor Current	3	nA	3	nA (1213)
<hr/>				
Total Chlorine (0xFF2)				
Total Chlorine	1	ppm	1	ppm (1423)
Temperature	2	degree C	2	degree C (1001)
		degree F	2	degree F (1002)
Sensor Current	3	nA	3	nA (1213)
<hr/>				
Chloramine (0xFF4)				
Chloramine	1	ppm	1	ppm (1423)
Temperature	2	degree C	2	degree C (1001)
		degree F	2	degree F (1002)
Sensor Current	3	nA	3	nA (1213)

6.3 Transducer Block Operations — Configuration and Calibration

6.3.1 DeltaV Explorer Transducer Block Interface

1. Context Menu

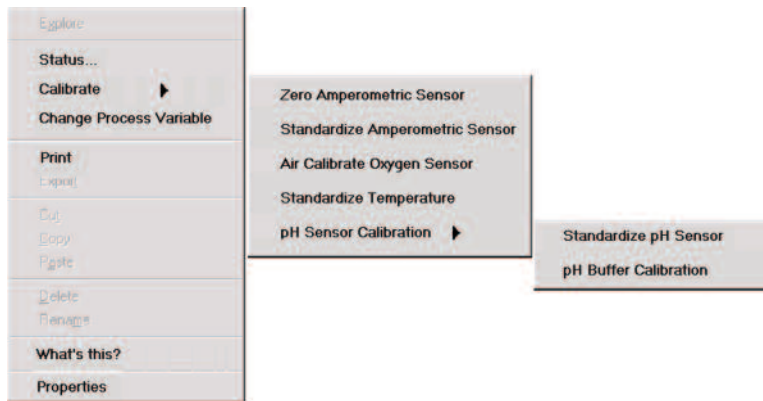

The DeltaV Explorer exposes methods for changing the process variable, zeroing and standardizing the sensors, calibrating oxygen sensors in air, standardizing the temperature measurement, and standardizing and buffer calibrating the pH sensor (free chlorine only).

2. Transducer Block Properties

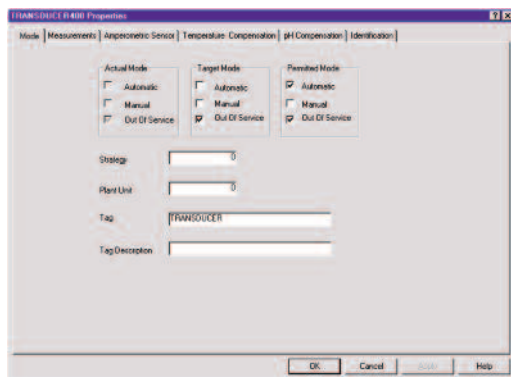

The Transducer Block Properties Windows allow full configuration of the 5081A-FF. The Transducer Block must be put in the Out of Service Mode (OOS) to allow configuration parameters to be changed. The following parameters are exposed on each tab:

- **Mode Tab:** Allows the Transducer Block to be switched between the Auto and Out of Service Modes.
- **Measurement Tab:** Shows all of the 5081A-FF live measurements and their status.
- **Amperometric Sensor Tab:** Contains all of the configuration and calibration parameters for the oxygen, chlorine, or ozone sensor.
- **Temperature Compensation Tab:** Contains all of the configuration parameters for temperature compensation and the temperature measurement.
- **Identification Tab:** Contains serial and revision numbers and the passcode for the infrared remote controller.
- **pH Compensation (free chlorine only):** Contains all of the configuration, calibration, and diagnostic parameters for the pH sensor.

3. Transducer Block Status

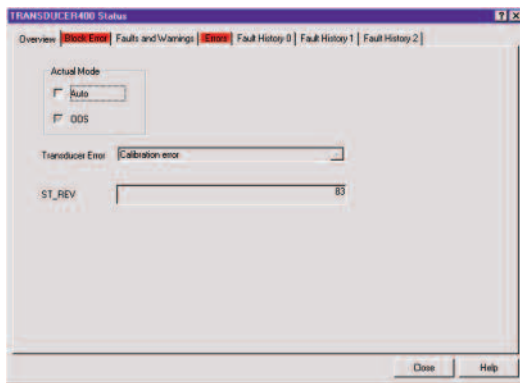

The Transducer Block Status Windows show all of the diagnostic faults, warnings, and errors. The meaning of these diagnostic messages and troubleshooting procedures for them can be found in the Troubleshooting section of this manual.

In addition to current diagnostic messages, the Transducer Block Status Windows also show the last three fault conditions: `fault_history_0`, `fault_history_1`, and `fault_history_2`, respectively.

6.4 Model 5081-A-FF — Device Summary

Manufacturer: Rosemount Analytical (524149)

Device Type: 4083

Device Revision: 1

Function Blocks: Four (4) AI Blocks, One (1) PID Block

Link Active Scheduler: Yes

ITK Version: 6.0

Channels:

- 1 — Measurement (oxygen, chlorine, or ozone)
- 2 — Temperature
- 3 — Sensor Current
- 4 — pH Measurement (Free Chlorine Mode only)

NOTE

In the sections of this manual describing operation with DeltaV, oxygen, chlorine, and ozone measurements are referred to collectively as amperometric measurements. The sensors are called amperometric sensors.

TABLE 6-2. Model 5081-A-FF Parameters and Methods

R I	FF Parameter Mnemonic	Description	Data Type / Size	Store	Read / Write
	(parentheses denote parameters used within methods)				
	Amperometric Measurement Parameters				
	method_change_pv_type	Change Primary Value Type			
13	PRIMARY_VALUE_TYPE	Oxygen (0xFFF0); Free Chlorine (0xFFF1); Total Chlorine (0xFFF2); Ozone (0xFFF3); Chloramine (0xFFF4)	uns16, 2	S	RW
14	PRIMARY_VALUE	Amperometric Concentration value and status, DS-65	DS-65, 5	D	R
15	PRIMARY_VALUE_RANGE	Appropriate Range is reported by the 508 A-FF	DS-68, 11	S	R
16	PRIMARY_VALUE_UNIT	1423 (ppm); 1424 (ppb); % = 1342 (%)	uns16, 2	S	RW
35	SENSOR_CURRENT	Sensor Current value and status, DS-65 always in nA (1213)	DS-65, 5		R
19	ZERO_CURRENT	Amperometric Sensor Current when Sensor was last zeroed, always in nA (1213)	float, 4	S	RW
20	SENSITIVITY	Slope of Amperometric calibration in nA/ppm	float, 4	S	RW
	Amperometric Calibration Parameters				
	method_sensor_zero	Zero Amperometric Sensor			
	method_pv_cal	Calibrate Amperometric Sensor			
W	(SENSOR_ZERO_CAL)	Change Sensor current offset to zero the reading; 1= Begin zero calibration by not using sensor current offset; 2= abort; 3= execute Sensor zero	D	84	uns8, 1
18	(SAMPLE_CAL)	Amperometric single point calibration or First point of Dual Slope calibration	float, 4	S	W
21	AMP_STABLIZE_TIME	Period of time the reading should be stable before accepting the reading as a calibration entry in seconds.	float, 4	S	RW
22	AMP_SPAN_STABLIZE_VALUE	Maximum reading fluctuation before accepting the reading as a calibration entry	float, 4	S	RW
23	AMP_ZERO_STABLIZE_VALUE	Maximum reading fluctuation before accepting the reading as a calibration entry in primary value units	float, 4	S	RW
	Diagnostics				
48	ADDITIONAL_TRANSMITTER_STATUS_FAULTS	2 bytes Fault messages; bit enumerated	uns16, 2	D	R
49	ADDITIONAL_TRANSMITTER_STATUS_WARNINGS	2 bytes Warning messages; bit enumerated	uns16, 2	D	R
50	ADDITIONAL_TRANSMITTER_STATUS_ERROR	2 bytes Error and Status messages; bit enumerated	uns16, 2	D	R
72	FAULT_HISTORY_0	Fault history (most recent fault history) bit-enumerated (fault message - most significant bit = 1) (warn message - most significant bit = 0)	uns16, 2	N	R
73	FAULT_HISTORY_1	Fault history (previous fault history) bit-enumerated (fault message - most significant bit = 1) (warn message - most significant bit = 0)	uns16, 2	N	R
74	FAULT_HISTORY_2	Fault history (prior fault history) bit-enumerated (fault message - most significant bit = 1) (warn message - most significant bit = 0)	uns16, 2	N	R
	Dissolved Oxygen Parameters				
	method_oxygen_air_cal	Air Calibrate Oxygen Sensor			
17	SENSOR_TYPE_OXYGEN	Default= 499ADO (0xFFF0); 499ATRDO (0xFFF1); SdO1 (0xFFF2); SdO2 (0xFFF3)	uns16, 2	S	RW
24	SALINITY	Salinity value used for Oxygen measurement, in parts per thousand units	float, 4	S	RW

Table 6-2 continued on following page.

TABLE 6-2. Model 5081-A-FF Parameters and Methods (continued)

25	BAR_PRESSURE	Barometric pressure used for Oxygen Air Cal	float, 4	S	RW
26	BAR_PRESSURE_UNIT	Barometric pressure unit. Acceptable units are: in Hg (1155); mm Hg (1157); bar (1137); k Pa (1133); atm (1140)	uns16, 2	S	RW
W	(AIR_CAL)	Any non zero value performs Air calibration on Oxygen Sensor	D	85	uns8, 1
27	PERCENT_SATURATION_PRESSURE	Pressure used for percent saturation calculation which may be different than the air Pressure during Air Cal; Acceptable units are: in Hg (1155); mm Hg (1157); bar (1137); k Pa (1133); atm (1140)	float, 4	S	RW
Chlorine Parameters					
28	CHLORINE_CALIBRATION_RANGES	Selects Single=1 or Dual=2 Range calibration for Chlorine sensor	uns8, 1	S	RW
Temperature Parameters					
method_sv_cal		Standardize Temperature			
29	SECONDARY_VALUE	Process temperature value and Status, DS-65	DS-65, 5	D	R
30	SECONDARY_VALUE_UNIT	Degree C (1001) or degree F (1002)	uns16, 2	S	RW
31	SENSOR_TEMP_COMP	Indicates Manual (1) or Automatic (2) temperature compensation	uns8, 1	S	RW
32	SENSOR_TEMP_MAN_VALUE	Temperature value used in Manual Compensation; units are given by secondary value unit.	float, 4	S	RW
33	SENSOR_TYPE_TEMP	Temperature Sensor type is automatically recognized and available at this index. 128= Pt 100, 200= Pt 1000 and 0xFFFE= 22K Thermistor	uns16, 2	D	R
34	(TEMP_SENSOR_CAL)	Desired temperature reading after calibration	float, 4	S	W
pH Parameters (Free Chlorine Mode Only)					
36	PH_VALUE	pH value, DS-65, units always in pH (1422)	DS-65, 5	D	R
38	PH_COMPENSATION_MODE_AND_PREAMP_SELECTION	Manual (0) or Auto (1) with internal preamp Manual (2) or Auto (3) with external preamp	uns8, 1	S	RW
39	MANUAL_PH_VALUE	pH value used for manual pH compensation	float, 4	S	RW
40	PH_SENSOR_MV	Output of pH sensor in mV	float, 4	D	R
43	PH_SLOPE	units in mV/pH	float, 4	S	RW
44	PH_ZERO	units in mV	float, 4	S	RW
pH Calibration (Free Chlorine Mode Only)					
method_standardize_ph		Standardize pH			
method_ph_buffer_cal		pH Buffer Calibration			
37	(PH_SAMPLE_CAL)	Desired pH reading after calibration	float, 4	S	W
41	(PH_CAL_POINT_HI)	Entering a value initiates a manual pH buffer calibration.	float, 4	S	RW
42	(PH_CAL_POINT_LO)	Entering a value completes a manual pH buffer calibration.	float, 4	S	RW
59	PH_STABILIZE_TIME	Period of time the pH reading should be stable before accepting the reading as a calibration entry, units are seconds.	float, 4	S	RW
60	PH_STABILIZE_VALUE	Maximum reading fluctuation before accepting the reading as a calibration entry, units are pH.	float, 4	S	RW
57	(BEGIN_PH_AUTO_CALIBRATION)	Indicates start of PH Autocalibration Any non zero value starts the calibration.	uns8, 1	D	W
58	BUFFER_STANDARD	The table of Buffer Standard used in Automatic Buffer recognition. 0=Manual; 1= Std; 2= DIN; 3= Ingold; 4= Merck	uns8, 1	S	RW
61	(AUTOBUFFER_INDEX)	Index of Buffer Standard in a standard table, used in Automatic Buffer recognition.	uns8, 1	N	R
62	(AUTOBUFFER_VALUE)	Value of Buffer Standard in a standard table, used in Automatic Buffer recognition.	float, 4	N	R
63	(SELECT_NEXT_AUTOBUFFER)	selects next Buffer Standard in a standard table Any non zero value selects next autobuffer, used in Automatic Buffer recognition.	uns8, 1	D	W

Table 6-2 continued on following page.

TABLE 6-2. Model 5081-A-FF Parameters and Methods (continued)

64	(SELECT_PREVIOUS_AUTOBUFFER)	selects previous Buffer Standard in a standard table Any non zero value selects previous autobuffer, used in Automatic Buffer recognition.	uns8, 1	D	W
65	(AUTOBUFFER_NUMBER)	Indicates first or second calibration points, used in Automatic Buffer recognition.	uns8, 1	N	W
pH Diagnostics (Free Chlorine Mode Only)					
45	PH_GLASS_IMPEDANCE	pH Glass electrode impedance in megOhm units (1283)	float, 4	S	R
66	ENABLE/DISABLE_DIAGNOSTIC_FAULT_SETPOINTS	Enable/Disable diagnostic features 0 = disable 1 = enable	uns8, 1	S	RW
67	GLASS_FAULT_HIGH_SETPOINT	Glass impedance Fault high limit in megOhm units (1283)	float, 4	S	RW
68	GLASS_FAULT_LOW_SETPOINT	Glass impedance Fault low limit, in megOhm units (1283)	float, 4	S	RW
69	PH_ZERO_OFFSET_ERROR_LIMIT	Maximum acceptable Zero in mV units (1243)	float, 4	S	RW
70	IMPEDANCE_TEMP_COMPENSATION	Enable/Disable Glass Impedance temperature compensation 0 = disable 1= enable	uns8, 1	S	RW
Identification and Local Setting Parameters					
51	S/W_REV_LEVEL	CPU Board software revision number	uns16, 2	S	R
52	H/W_REV_LEVEL	CPU Board hardware revision number	uns8, 1	S	R
54	FINAL_ASSEMBLY_NUMBER	Final CPU Board assembly number	uns32, 4	S	R
55	LOCAL_OPERATOR_INTERFACE_TAG	Password of IR remote control that is recognized. must be between 0 to 999	uns16, 2	S	RW
56	EXIT_HOLD_MODE	Puts device in OOS mode: 0 = No Hold, 1 = Hold	uns8	S	RW
47	RESET_TRANSDUCER	CPU Board Power on reset, User Defaults or factory defaults . 1=Power-On; 2=Reset user EEPROM (Index #71, bit0=0); 3=Reset all EEPROM (Index #71=00) All Lists to be read after a valid write, including Lists #117 and #118	uns8, 1	S	W
Standard Transducer Block Parameters					
1	ST_REV	The revision level of the static data associated with the function block. Used by the host to determine when to re-read the static data.			R
2	TAG_DESC	The user description of the intended application of the block.			RW
3	STRATEGY	The Strategy field can be used to identify a grouping of blocks. Can be used for any purpose by the user.			RW
4	ALERT_KEY	Identification number that may be used by the host system to sort alarms and other device information.			RW
5	MODE_BLK	Allows the user to set the Target, Permitted, and Normal device modes. Displays the Actual mode.	int8, 1	D	R
6	BLOCK_ERR	Reflects the error status associated with the hardware or software in the block. It is a bit string so multiple errors may be shown.	int16, 2	D	R
7	UPDATE_EVT				
8	BLOCK_ALM		uns16, 2	D	R
9	TRANSDUCER_DIRECTORY	Directory that specifies the number and the starting indices of the transducers in the transducer block.			
10	TRANSDUCER_TYPE	Identifies the transducer type (65535).			
11	XD_ERROR	A transducer block sub-code. XD_ERROR contains the highest priority alarm that has been activated in the TB_DETAILED_STATUS parameter.			
12	COLLECTION_DIRECTORY	A directory that specifies the number, starting indices, and DD item ID's of the data collections in each transducer within a transducer block. Used by the host for efficient transfer of information.			

SECTION 7.0 PROGRAMMING

- 7.1 General
- 7.2 Default Settings
- 7.3 Temperature Settings
- 7.4 Display
- 7.5 Calibration Setup
- 7.6 Line Frequency
- 7.7 pH Measurement
- 7.8 Barometric Pressure

7.1 GENERAL

This section describes how to do the following:

1. enable and disable automatic temperature correction
2. program the type measurement (oxygen, ozone, or chlorine)
3. setup stabilization criteria for calibration
4. enable automatic pH correction for chlorine measurements
5. choose units for barometric pressure (oxygen only)
6. choose limits for diagnostic fault messages

Each section contains definitions of terms used, programming instructions using the infrared remote controller, and programming instructions using DeltaV.

7.2 DEFAULT SETTINGS

Table 7-1 lists the default settings for the 5081-A transmitter. The transmitter is configured at the factory to measure oxygen.

IMPORTANT

Before changing any default settings, configure the transmitter for the measurement you want to make: oxygen, free chlorine, total chlorine, or ozone. Changing the measurement ALWAYS returns the transmitter to factory default settings.

TABLE 7-1. Default Settings

ITEM	MNEMONIC	CHOICES	DEFAULT
A. Temperature compensation	tEMP		
1. Automatic	tAUtO	On or Off	On
2. Manual	tMAn	-25.0 to 150°C	25°C
B. Display	dISPLAY		
1. Type of measurement	tYPE	Oxygen, ozone, free chlorine, total chlorine	oxygen
2. Units (oxygen only)	Unit	ppm, ppb, or %	ppm
3. Units (ozone only)	Unit	ppm or ppb	ppm
4. Sensor (oxygen only)	SEnSor	499ADO, 499ATrDO, Hx438 or Gx338, other biopharm	499ADO
5. Temperature units	tEMP	°C or °F	°C
6. Output current units	OutPut	mA or % of full scale	mA
7. Security code	CodE	000 to 999	000
C. Calibration Setup	CAL SETUP		
1. Stabilization criteria	StAbiLiSE		
a. time	tiME	00 to 99 sec	10 sec
b. change	dELtA		
if oxygen (ppm or ppb)		0.01 to 9.99 ppm	0.05 ppm
if oxygen (%)		1 to 100 %	1 %
if ozone		0.01 to 9.99 ppm	0.01 ppm
if chlorine		0.01 to 9.99 ppm	0.05 ppm
2. Salinity (oxygen only)	SALntY	0.0 to 36.0	0.0
3. Slope (chlorine only)	SLOPE	single or dual	single
4. Maximum zero limit	LiMit		
a. if oxygen (ppm)		00.00 to 10.00 ppm	0.05 ppm
b. if oxygen (ppb)		000.0 to 999.9 ppb	2.0 ppb
c. if oxygen (%)		000.0 to 999.9 %	1%
d. if ozone		00.00 to 10.00 ppm	0.01 ppm
e. if chlorine		00.00 to 10.00 ppm	0.05 ppm
D. Line Frequency	LinE FrEq	50 or 60 Hz	60 Hz
E. HART	HARt		
1. Address	AddrESS	00 to 15	00
2. Preamble	PrEAMb	05 to 20	05
3. Burst	bUrSt	on or off	off
4. ID	Id	0000000 to 9999999	0000000
F. pH Settings (free chlorine only)			
1. Automatic pH correction	pH	on or off	on
2. Manual pH correction	MAn	0.00 to 14.00	7.00
3. Location of preamplifier	PAMP	transmitter or sensor	transmitter
4. pH sensor diagnostics	diAgnOSTiC		
a. reference offset	rOFFSEt	0 to 999	60
b. diagnostics	diAG	on or off	off
(1) glass impedance temperature correction	IMPtC	on or off	on
(2) glass impedance high	GFH	0 to 2000 MΩ	1000 MΩ
(3) glass impedance low	GFL	0 to 900 MΩ	10 MΩ
5. Calibration settings	PH CAL		
a. automatic buffer calibration	bAUtO	on or off	
b. buffer selection list	buFFER	see table in Section 13.1	standard
c. stabilization criteria	StAbiLiSE		
(1) time	tiME	0 to 99 sec	10 sec
(2) change	dELtA	0.02 to 0.50	0.02
G. Pressure settings (oxygen only)	BAr PrESS		
a. units	Unit	mm hg, kPa, atm, bar, in Hg	mm Hg
b. pressure for % sat calculations	% SAt P	0 to 9999	760 mm Hg

7.3 TEMPERATURE SETTINGS

7.3.1 Purpose

This section describes how to do the following:

1. Enable and disable automatic temperature compensation
2. Set a manual temperature compensation value for oxygen, chlorine, ozone, and pH measurements
3. Tell the transmitter the type of temperature element in the sensor

7.3.2 Definitions

1. **AUTOMATIC TEMPERATURE COMPENSATION - OXYGEN, CHLORINE, AND OZONE.** The oxygen, chlorine, and ozone sensors used with the 5081-A transmitter are membrane-covered amperometric sensors. The permeability of the membrane, or the ease with which the analyte passes through the membrane, is a function of temperature. As temperature increases, permeability increases, and the analyte diffuses more readily through the membrane. Because sensor current depends on diffusion rate, a temperature increase will cause the sensor current and transmitter reading to increase even though the concentration of analyte remained constant. A correction equation in the software automatically corrects for changes in membrane permeability caused by temperature. Temperature is also used in the pH correction applied to free chlorine readings and in automatic air calibration of oxygen sensors. In automatic temperature correction, the transmitter uses the temperature measured by the sensor for all calculations in which temperature is used.
2. **MANUAL TEMPERATURE COMPENSATION - OXYGEN, CHLORINE, AND OZONE.** In manual temperature compensation, the transmitter uses the temperature entered by the user for membrane permeability and pH corrections and for air calibration calculations. It does not use the actual process temperature. Do **NOT** use manual temperature correction unless the measurement and calibration temperatures differ by no more than about 2°C. Manual temperature correction is useful if the sensor temperature element has failed and a replacement sensor is not available.
3. **AUTOMATIC TEMPERATURE COMPENSATION - pH.** The transmitter uses a temperature-dependent factor to convert measured cell voltage to pH. In automatic temperature compensation the transmitter measures the temperature and automatically calculates the correct conversion factor. Temperature is also used in automatic buffer calibration. For maximum accuracy, use automatic temperature correction.
4. **MANUAL TEMPERATURE COMPENSATION - pH.** In manual temperature compensation, the transmitter converts measured voltage to pH using the temperature entered by the user. It does not use the actual process temperature. Do **NOT** use manual temperature compensation unless the process temperature varies no more than about 2°C or the pH is between 6 and 8. Manual temperature compensation is useful if the sensor temperature element has failed and a replacement sensor is not available.

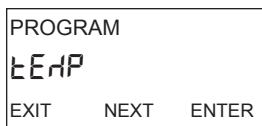
7.3.3 Procedure using the infrared remote controller

1. Press PROG on the remote controller.
2. Press NEXT until the **tEMP** submenu appears. Press ENTER.

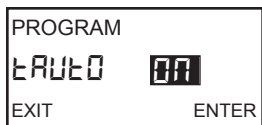

3. The screen displays the **tAUtO** (automatic temperature compensation) prompt. Press **3** or **6** to toggle between **On** and **OFF**. Press ENTER to save.

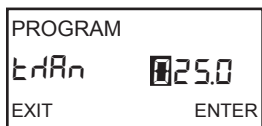

4. If you disable tAuto, the **tMAN** prompt appears. Use the arrow keys to change the temperature to the desired value. To enter a negative number, press **4** or **2** until no digit is flashing. Then press **3** or **6** to display the negative sign. **The temperature entered in this step will be used in all measurements (oxygen, chlorine, ozone, or pH), no matter what the process temperature is.** Press ENTER to save.

5. Press RESET to return to the process display.

7.3.4 Procedure using DeltaV

Access: DeltaV Explorer/Transducer Block/Properties/Temperature Compensation

1. Parameter: Auto/Manual Selection (SENSOR_TEMP_COMP)
Select automatic or manual temperature compensation
2. If manual temperature compensation was chosen:
Parameter: Manual Temperature (SENSOR_TEMP_MAN_VALUE)
Enter temperature value to be used with manual temperature compensation.

7.4 DISPLAY

7.4.1 Purpose

This section describes how to do the following:

1. Configure the transmitter to measure oxygen, free chlorine, total chlorine, or ozone
2. Choose concentration units
3. Set the temperature units to °C or °F
4. Set the output to current or percent of full scale
5. Enter a security code.

7.4.2 Definitions

1. **MEASUREMENT.** The transmitter can be configured to measure dissolved oxygen (ppm and ppb level), free chlorine, total chlorine, or ozone.
2. **FREE CHLORINE.** Free chlorine is the product of adding sodium hypochlorite (bleach), calcium hypochlorite (bleaching powder), or chlorine gas to fresh water. Free chlorine is the sum of hypochlorous acid (HOCl) and hypochlorite ion (OCl⁻)
3. **TOTAL CHLORINE.** Total chlorine is the sum of free and combined chlorine. Combined chlorine generally refers to chlorine oxidants in which chlorine is combined with ammonia or organic amines. Monochloramine, used to disinfect drinking water, is an example of combined chlorine. The term total chlorine also refers to other chlorine oxidants such as chlorine dioxide. To measure total chlorine, the sample must first be treated with a mixture of acetic acid and potassium iodide. Total chlorine reacts with iodide to produce an equivalent amount of iodine, which the sensor measures.
4. **OUTPUT CURRENT.** The transmitter generates a 4-20 mA output signal directly proportional to the concentration of oxygen, chlorine, or ozone in the sample. The output signal can be displayed as current (in mA) or as percent of full scale.
5. **SECURITY CODE.** The security code unlocks the transmitter and allows access to all menus.

7.4.3 Procedure using the infrared remote controller

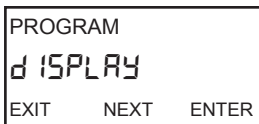

1. Press PROG on the remote controller.
2. Press NEXT until the **diSPLAy** submenu appears. Press ENTER.



3. Press **0** or **2** to display the desired measurement. Press ENTER to save.

O2	Dissolved oxygen (go to step 4)
CLrA	Monochloramine
tCL	Total chlorine
FCL	Free chlorine
O3	Ozone (go to step 7)



Although monochloramine is a choice, a monochloramine sensor is **NOT** currently available from Rosemount Analytical.

4. If you chose **O2** in step 3, the screen at left appears. Press **0** or **2** to display the desired units: **ppm**, **ppb**, or **%**. Press ENTER to save. Also, refer to step 6 for recommended settings to make for different types of sensors.



5. The screen at left appears. Press **0** or **2** to display the type of sensor. Press ENTER to save.

AdO	499ADO
trdO	499ATrDO
SdO1	Hx438 or Gx448 steam-sterilizable sensor
SdO2	Steam-sterilizable sensor from other manufacturer

Refer to step 6 for recommended sensor/unit combinations.

- For best results make the following settings based on the sensor being used.

Sensor	Units
499ADO	ppm or %
499ATrDO	ppb
Gx448	ppm or %
Hx438	ppm or %

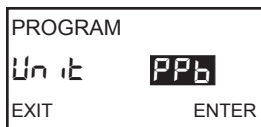

- If you chose **O3** in step 3, the screen at left appears. Press **2** or **5** to toggle between **ppm** and **ppb**. Press ENTER to save.
- Press RESET to return to the main display.

7.4.4 Procedure using DeltaV

- Access: DeltaV Explorer/Context menu
Change Process Variable Type (method_change_pv_type).
Select desired measurement (PV)
Although monochloramine is a choice, a monochloramine sensor is **NOT** currently available from Rosemount Analytical.
- If you chose O₂, select a sensor from the following table:

AdO	499ADO
trdO	499ATrDO
SdO1	Hx438 or Gx448 steam-sterilizable sensor
SdO2	Steam-sterilizable sensor from other manufacturer

Access: DeltaV Explorer/Transducer Block/Properties, Amperometric Sensor Tab
Parameter: Oxygen Sensor Type (SENSOR_TYPE_OXYGEN)
Select desired sensor

- On the Amperometric Sensor Tab -
Parameter: Primary Value Unit (PRIMARY_VALUE_UNIT)
Select the desired units. For best results, make the following settings based on the sensor used:

Sensor	Units
499ADO	ppm or %
499ATrDO	ppb
Gx448	ppm or %
Hx438	ppm or %

7.5 CALIBRATION SETUP

7.5.1 Purpose

This section describes how to do the following:

1. Enter stabilization criteria for calibration
2. Enter an upper limit for sensor zero
3. Enter a salinity value for air calibration of dissolved oxygen sensors
4. Enable dual slope calibration for free and total chlorine sensors.

7.5.2 Definitions

1. **STABILIZATION CRITERION.** The transmitter can be programmed not to accept calibration data until the reading has remained within a specified concentration range for a specified period of time. For example, a stability criterion of 0.05 ppm for 10 seconds means that calibration data will not be accepted until the reading changes less than 0.05 ppm over a 10-second period. The transmitter calculates the concentration using the present calibration data, or in the case of a first time calibration, the default sensitivity.
2. **SENSOR ZERO LIMIT.** Even in the complete absence of the substance being determined, all amperometric sensors generate a small current called the zero or residual current. The transmitter compensates for the residual current by subtracting it from the measured current before converting the result to a concentration value. The zero current varies from sensor to sensor. The transmitter can be programmed not to accept a zero current until the value has fallen below a reasonable limit.
3. **SALINITY (DISSOLVED OXYGEN ONLY).** The solubility of oxygen in water depends on the concentration of dissolved salts in the water. Increasing the concentration decreases the solubility. If the salt concentration is greater than about 1000 ppm, the accuracy of the measurement can be improved by applying a salinity correction. Enter the salinity as parts per thousand (‰). One percent is ten part per thousand.
4. **DUAL SLOPE CALIBRATION (FREE AND TOTAL CHLORINE ONLY).** Free and total chlorine sensors from Rosemount Analytical (Model 499ACL-01 and 499ACL-02) become non-linear at high concentrations of chlorine. Dual slope calibration allows the analyzer to correct for the non-linearity of the sensor. For more information see Section 10.4 or 11.4.

7.5.3 Procedure using the infrared remote controller

1. Press PROG on the remote controller.

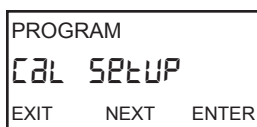

PROGRAM
CAL SETUP
EXIT NEXT ENTER

2. Press NEXT until the **CAL SETUP** submenu appears. Press ENTER.

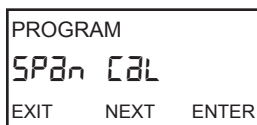

PROGRAM
SPAN CAL
EXIT NEXT ENTER

3. The screen displays the **SPAN CAL** prompt. To set the stabilization criteria, press ENTER.

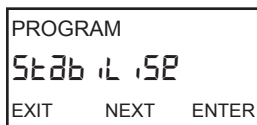

PROGRAM
StABiLiSE
EXIT NEXT ENTER

4. The screen displays the **StABiLiSE** prompt. Press ENTER.

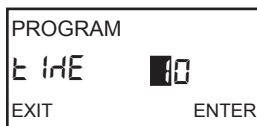

PROGRAM
TIME 10
EXIT ENTER

5. Set the stabilization time between 0 and 99 seconds. The default value is 10 seconds. Press ENTER to save.

Procedure continued on following page.

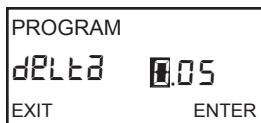

6. Set the stabilization range to between 0.01 and 9.99 ppm. The default values are shown in the table. Press ENTER to save.

Oxygen	0.05 ppm or 1%
Free chlorine	0.05 ppm
Total chlorine	0.05 ppm
Ozone	0.01 ppm

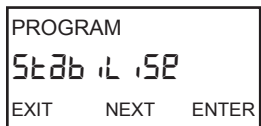

7. The display returns to the **StAbLiSE** prompt. Press NEXT. The next screen depends on the measurement being made. For free or total chlorine see step 8. For oxygen, see step 9. For ozone see step 10.

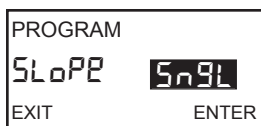

8. If the measurement is free or total chlorine, the **SLOPE** prompt appears. Use **↵** or **↩** to toggle between **Sngl** (single) or **duAL** (dual) slope. Press ENTER. Go to step 10.

NOTE

For the vast majority of applications, single slope calibration is acceptable. Dual slope calibration is useful in fewer than 5 % of applications.



9. If the measurement is oxygen, the **SALnty** (salinity) prompt appears. Use the arrow keys to enter the salinity of the water. Press ENTER. Go to step 10.

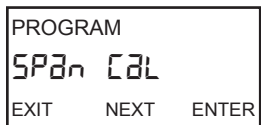

10. The display returns to the **SPAn CAL** screen. Press NEXT.



11. The **0 CAL** screen appears. Press ENTER.

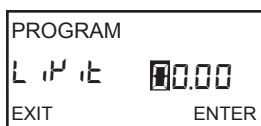

12. Enter the desired zero limit. The units are the same as the units programmed in Section 7.5. Default limits are given in the table.

Oxygen (ppm)	0.05 ppm
Oxygen (ppb)	2.0 ppb
Oxygen (% saturation)	1%
Free chlorine	0.05 ppm
Total chlorine	0.05 ppm
Ozone	0.01 ppm or 10 ppb

13. Press RESET to return to the main display.

7.5.4 Procedure using DeltaV

Access: DeltaV Explorer/Transducer Block/Properties, Amperometric Sensor Tab

1. Parameter: Amperometric Stabilize Time (AMP_SPAN_STABILIZE_TIME)
Set the stabilization time between 0 and 99 seconds. The default value is 10 seconds.
2. Parameter: Amperometric Stabilize Value (AMP_SPAN_STABILIZE_VALUE)
Set the stabilization range to between 0.01 and 9.99 ppm. The default values are shown in the table:

Oxygen	0.05 ppm or 1%
Free chlorine	0.05 ppm
Total chlorine	0.05 ppm
Ozone	0.01 ppm

3. Parameter: Salinity (SALINITY).
Enter the salinity of the water.
4. Parameter: Zero Limit (AMP_ZERO_STABILIZE_VALUE)
Enter the desired zero limit. Default limits are given in the table:

Oxygen (ppm)	0.05 ppm
Oxygen (ppb)	2.0 ppb
Oxygen (% saturation)	1%
Free chlorine	0.05 ppm
Total chlorine	0.05 ppm
Ozone	0.01 ppm or 10 ppb

7.6 LINE FREQUENCY

7.6.1 Purpose

This section describes how to maximize noise rejection by entering the frequency of the mains power into the transmitter.

7.6.2 Procedure using the infrared remote controller.

1. Press PROG on the remote controller.

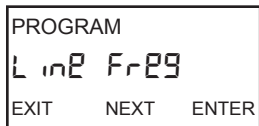

2. Press NEXT until the **LinE FrEq** submenu appears. Press ENTER.

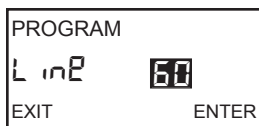

3. Use **3** or **5** to toggle the line frequency between **50** and **60** Hz. Press ENTER to save.
4. Press RESET to return to the main display.

7.7 pH MEASUREMENT

NOTE

The pH measurement submenu appears only if the transmitter has been configured to measure free chlorine. pH is not available with any other measurement.

7.7.1 Purpose

This section describes how to do the following:

1. Enable and disable automatic pH correction for free chlorine measurements
2. Set a pH value for manual pH correction
3. Enable and disable pH sensor diagnostics
4. Set upper and lower limits for glass impedance diagnostics
5. Enable and disable automatic pH calibration
6. Set stability criteria for automatic pH buffer calibration.

7.7.2 Definitions

1. **AUTOMATIC pH CORRECTION.** Free chlorine is the sum of hypochlorous acid (HOCl) and hypochlorite ion (OCl⁻). The relative amount of each depends on pH. As pH increases, the concentration of HOCl decreases and the concentration of OCl⁻ increases. Because the sensor responds only to HOCl, a pH correction is necessary to properly convert the sensor current into a free chlorine reading. The transmitter uses both automatic and manual pH correction. In automatic pH correction the transmitter continuously monitors the pH of the sample and corrects the free chlorine reading for changes in pH. In manual pH correction, the user enters the pH of the sample. Generally, if the pH changes more than about 0.2 units over short periods of time, automatic pH correction is best. If the pH is relatively steady or subject only to seasonal changes, manual pH correction is adequate.
2. **REFERENCE OFFSET.** The transmitter reading can be changed to match the reading of a second pH meter. If the difference (converted to millivolts) between the transmitter reading and the desired value exceeds the programmed limit, the transmitter will not accept the new reading. To estimate the millivolt difference, multiply the pH difference by 60.
3. **pH SENSOR DIAGNOSTICS.** The transmitter continuously monitors the pH sensor for faults. A fault means that the sensor has failed or is possibly nearing failure. The only pH sensor diagnostic available in the 5081-A is glass impedance.
4. **GLASS IMPEDANCE.** The transmitter monitors the condition of the pH-sensitive glass membrane in the sensor by continuously measuring the impedance across the membrane. Typical impedance is 100 to 500 MΩ. A low impedance (<10 MΩ) means the glass membrane has cracked and the sensor must be replaced. An extremely high impedance (>1000MΩ) implies that the sensor is aging and may soon need replacement. High impedance might also mean that the glass membrane is no longer immersed in the process liquid.
5. **AUTOMATIC pH CALIBRATION.** The transmitter features both automatic and manual pH calibration. In automatic calibration, screen prompts direct the user through a two-point buffer calibration. The transmitter recognizes the buffers and uses temperature-corrected values in the calibration. The table in Section 13.1 lists the standard buffers the transmitter recognizes. The transmitter also recognizes several technical buffers: Merck, Ingold, and DIN 19267. During automatic calibration, the transmitter does not accept data until programmed stability limits have been met.
6. **MANUAL pH CALIBRATION.** If automatic pH calibration is deactivated, the user must perform a manual calibration. In manual calibration the user judges when readings are stable and manually enters the buffer values. **Because manual calibration greatly increases the chance of making an error, the use of automatic calibration is strongly recommended.**

7.7.3 Procedure using the infrared remote controller

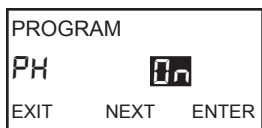

1. Press PROG on the remote controller.
2. Press NEXT until the **PH** submenu appears. **On** will be flashing, indicating that the pH measurement and automatic pH correction of free chlorine has been enabled.

To keep automatic pH correction enabled, press ENTER. Go to step 3.

To disable automatic pH correction, use **⏪** or **⏩** to change **On** to **OFF** and press ENTER. The **MAN** prompt appears. Use the arrow keys to enter the pH of the sample. Press ENTER to save. Press RESET to return to the main display.

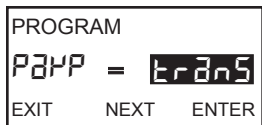

3. The screen displays the **PAMP** (preamplifier) prompt. Press **⏪** or **⏩** to toggle between **trAnS** and **SnSr**.

trAnS	Preamplifier is in the transmitter
SnSr	Preamplifier is in the sensor or in a remote junction box

Press ENTER to save.

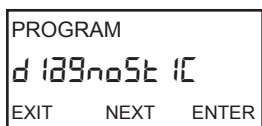

4. The screen displays the **dIAGnOStIC** submenu header. Prompts under this header allow the user to change the reference offset and pH sensor diagnostic limits.

The default settings are:

reference offset	60 mV
pH sensor diagnostics	off

To keep the default settings, press NEXT. Go to step 11.

To change the reference offset or to enable or make changes to the glass diagnostic settings, press ENTER. Go to step 5.

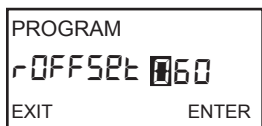

5. The **rOFFSEt** (reference offset) prompt appears. Use the arrow keys to change the offset to the desired value in mV. Press ENTER to save.

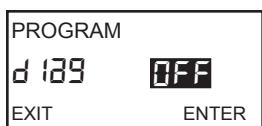

6. The **dIAG** (diagnostics) prompt appears. Press **⏪** or **⏩** to toggle between **OFF** (disable) or **On** (enable). Press ENTER to save.

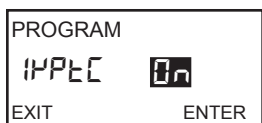

7. The **IMPtC** (glass impedance temperature correction) prompt appears. Press **⏪** or **⏩** to toggle between **OFF** (disable) or **On** (enable). Because glass impedance is a strong function of temperature, correcting glass impedance for temperature effects is strongly recommended. Press ENTER to save.

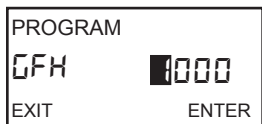

8. The **GFH** (glass fault high) prompt appears. Use the arrow keys to change the setting to the desired value. The default setting is 1000 MΩ. Entering 0000 disables the feature. Press ENTER to save.

When the glass electrode impedance exceeds the limit, the transmitter displays the **GLASSFAIL** diagnostic message and sets a fault condition.

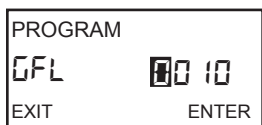

9. The **GFL** (glass fault low) prompt appears. Use the arrow keys to change the setting to the desired value. The default setting is 10 MΩ. Entering 0000 disables the feature. Press ENTER to save.

When the glass electrode impedance falls below the limit, the transmitter displays the **GLASSFAIL** diagnostic message and sets a fault condition.

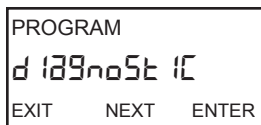

← 10. Once diagnostic limits have been set, the display returns to the **dIagnOStIC** sub-menu header. Press NEXT.

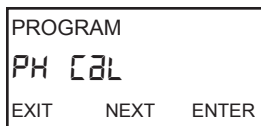

← 11. The **PH CAL** submenu header appears. Prompts under this header allow the user to enable or disable automatic buffer calibration, select the buffers to be used, and set stabilization criteria for pH calibration. The default settings are:

Automatic buffer calibration	On
Buffers	Standard (see Section 7.8.2)
Stabilization	<0.02 pH in 10 seconds

To make changes to the pH calibration parameters, press ENTER. Go to step 12.

To leave settings at their default values press EXIT to leave the submenu.

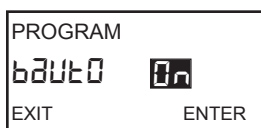

← 12. The **bAutO** (automatic buffer calibration) prompt appears. Press **3** or **5** to toggle between **OFF** (disable) or **On** (enable). Press ENTER to save. Keeping automatic buffer calibration enabled is strongly recommended.

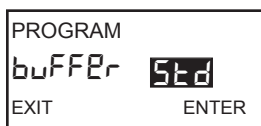

← 13. The **buFFEr** prompt appears. Press **3** or **5** to scroll through the list of available buffers. See Section 13.1 for a list of the buffer values.

Std	Standard buffers
ErC	Merck buffers
InG	Ingold buffers
din	DIN 19267 buffers

Press ENTER to save.

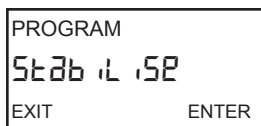

← 14. The **StAbiLiSE** (stabilize) prompt appears. To change stabilization criteria, press ENTER. To leave stabilization criteria at the default values, press EXIT.

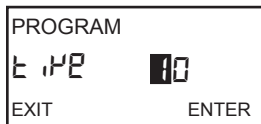

← 15. Set the stabilization time between 0 and 99 seconds. The default value is 10 seconds. Press ENTER to save.



← 16. Set the stabilization range to between 0.02 and 0.50 pH. Press ENTER to save.

17. Press RESET to return to the main display.

7.7.4 Procedure using DeltaV

Access: DeltaV Explorer/Transducer Block/Properties, pH Compensation Tab

1. pH Compensation (Auto/Manual) and Preamp Location

Parameter: pH Compensation/Preamp Location (PH_COMPENSATION_MODE)

Select the pH compensation mode and preamp location from the following table:

Description	Value	Digital Equivalent
Automatic pH Compensation with Preamp in Transmitter	Auto, Int.	0
Manual pH Compensation with Preamp in Transmitter	Man, Int.	1
Automatic pH Compensation with Sensor Preamp	Auto, Sensor	2
Manual pH Compensation with Sensor Preamp	Man, Sensor	3

2. If manual pH compensation was chosen,

Parameter: Manual pH Value (MANUAL_PH_VALUE)

Enter the desired manual pH value.

3. To enable/disable impedance diagnostic:

Parameter: Impedance Diagnostics (ENABLE_DIAGNOSTIC_FAULT_SETPOINT)

Enter the desired value.

4. Enter the high glass impedance fault limit. The default is 1000 M Ω .

Parameter: Glass Fault High Setpoint (GLASS_FAULT_HIGH_SETPOINT)

5. Enter the low glass impedance fault limit. The default is 10 M Ω .

Parameter: Glass Fault Low Setpoint (GLASS_FAULT_LOW_SETPOINT)

6. Enable or disable glass impedance temperature correction. Because glass impedance is a strong function of temperature, correcting glass impedance for temperature effects is strongly recommended.

Parameter: Impedance Temperature Compensation (IMPEDANCE_TEMPERATURE_COMPENSATION_PH)

7. Enter the reference offset limit. Default is 60 mV.

Parameter: Zero Offset Error Limit (ZERO_OFFSET_ERROR_LIMIT)

8. Select manual buffer calibration or automatic buffer calibration using the buffers listed in the table below. More information on the buffers listed can be found in Section 13.1. Using automatic buffer calibration is strongly recommended.

Description	Value	Digital Equivalent
Manual buffer calibration	Manual	0
Standard buffers	Std	1
DIN 19267 buffer	DIN	2
Ingold buffers	Ingold	3
Merck buffers	Merck	4

Parameter: Buffer Calibration (BUFFER_STANDARD)

9. Set the stabilize time for automatic buffer calibration. The range is 0 to 99 sec. The default is 10 sec.

Parameter: pH Stabilize Time (PH_STABILIZE_TIME)

Enter the desired value.

10. Set the stabilization value for automatic buffer calibration. The range is 0.02 to 0.50 pH. The default is 0.02 pH.

Parameter: pH Stabilize Value (PH_STABILIZE_VALUE)

Enter the desired value.

7.8 BAROMETRIC PRESSURE

NOTE

The barometric pressure submenu appears only if the transmitter has been configured to measure oxygen.

7.8.1 Purpose

This section describes how to do the following

1. Set the units for barometric pressure
2. Enter a pressure other than the calibration pressure for percent saturation measurements.

7.8.2 Definitions

1. **BAROMETRIC PRESSURE.** Because the current generated by an amperometric oxygen sensor is directly proportional to the partial pressure of oxygen, the sensor is generally calibrated by exposing it to water saturated air. See Section 9.1 for more information. To calculate the equivalent concentration of oxygen in water in ppm, the transmitter must know the temperature and barometric pressure. This submenu lets the user specify the units for barometric pressure.
2. **PERCENT SATURATION PRESSURE.** Oxygen is sometimes measured in units of percent saturation. Percent saturation is the concentration of oxygen divided by the maximum amount of oxygen the water can hold (the saturation concentration) at the temperature and pressure of the measurement. Generally, the pressure during the measurement is assumed to be the same as the pressure when the sensor was calibrated. If the measurement and calibration pressures differ, the measurement pressure can be entered as a separate variable.

7.8.3 Procedure using the infrared remote controller

1. Press PROG on the remote controller.

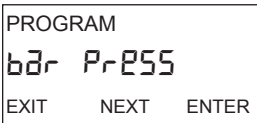

2. Press NEXT until the **bAr PRESS** submenu appears. Press ENTER.



3. The **Unit** prompt appears. Press **3** or **6** to scroll through the list of units:

nnHG	mm Hg
1000PA	kPa
Atn	atm
bAr	bar
InHG	in Hg

Press ENTER to save.

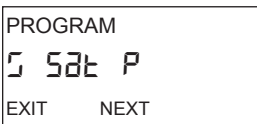

4. If % saturation units were selected in Section 7.5, the **% SA t P** (saturation pressure) prompt appears. Press NEXT.

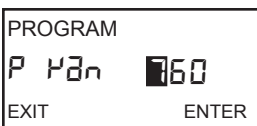

5. Use the arrow keys to enter the desired pressure. The transmitter will use this pressure to calculate percent saturation. Press ENTER.

6. Press RESET to return to the main display.

7.8.4 Procedure using DeltaV

Access: DeltaV Explorer/Transducer Block/Properties, Amperometric Sensor Tab

1. Enter the desired barometric pressure units from the following:

mm Hg
kPa
atm
bar
in Hg

Parameter: Barometric Pressure Unit (BAR_PRESSURE_UNIT)

2. If % saturation units were selected, enter the desired % saturation pressure.

Parameter: Percent Saturation Pressure (PERCENT_SATURATION_PRESSURE)

SECTION 8.0

CALIBRATION — TEMPERATURE

8.1 INTRODUCTION

All four amperometric sensors (oxygen, ozone, free chlorine, and total chlorine) are membrane-covered sensors. As the sensor operates, the analyte (the substance to be determined) diffuses through the membrane and is consumed at an electrode immediately behind the membrane. The reaction produces a current that depends on the rate at which the analyte diffuses through the membrane. The diffusion rate, in turn, depends on the concentration of the analyte and how easily it passes through the membrane (the membrane permeability). Because the membrane permeability is a function of temperature, the sensor current will change if the temperature changes. To correct for changes in sensor current caused by temperature, the transmitter automatically applies a membrane permeability correction. Although the membrane permeability is different for each sensor, the change is about 3%/°C at 25°C, so a 1°C error in temperature produces about a 3% error in the reading.

Temperature plays an additional role in oxygen measurements. Oxygen sensors are calibrated by exposing them to water-saturated air, which, from the point of view of the sensor, is equivalent to water saturated with atmospheric oxygen (see Section 9.1 for more information). During calibration, the transmitter calculates the solubility of atmospheric oxygen in water using the following steps. First, the transmitter measures the temperature. From the temperature, the transmitter calculates the vapor pressure of water and, using the barometric pressure, calculates the partial pressure of atmospheric oxygen. Once the transmitter knows the partial pressure, it calculates the equilibrium solubility of oxygen in water using a temperature-dependent factor called the Bunsen coefficient. Overall, a 1°C error in the temperature measurement produces about a 2% error in the solubility calculated during calibration and about the same error in subsequent measurements.

Temperature is also important in the pH measurement required to correct free chlorine readings.

1. The transmitter uses a temperature dependent factor to convert measured cell voltage to pH. Normally, a slight inaccuracy in the temperature reading is unimportant unless the pH reading is significantly different from 7.00. Even then, the error is small. For example, at pH 12 and 25°C, a 1°C error produces a pH error less than ± 0.02 .
2. During auto calibration, the transmitter recognizes the buffer being used and calculates the actual pH of the buffer at the measured temperature. Because the pH of most buffers changes only slightly with temperature, reasonable errors in temperature do not produce large errors in the buffer pH. For example, a 1°C error causes **at most** an error of ± 0.03 in the calculated buffer pH.

Without calibration the accuracy of the temperature measurement is about $\pm 0.4^\circ\text{C}$. Calibrate the transmitter if

1. $\pm 0.4^\circ\text{C}$ accuracy is not acceptable
2. the temperature measurement is suspected of being in error. Calibrate temperature by making the transmitter reading match the temperature measured with a standard thermometer.

8.2. PROCEDURE USING THE INFRARED REMOTE CONTROLLER

1. Place the sensor and a calibrated reference thermometer in a container of water at ambient temperature. Be sure the temperature element in the sensor is completely submerged by keeping the sensor tip at least three inches below the water level. Stir continuously. Allow at least 20 minutes for the standard thermometer, sensor, and water to reach constant temperature.

```

CALIBRATE
tEMP Adj
EXIT  NEXT  ENTER
  
```

```

CALIBRATE
tEMP  25.0
EXIT      ENTER
  
```

2. Press CAL on the remote controller.
3. Press NEXT until the **tEMP Adj** submenu appears. Press Enter.
4. The **tEMP** prompt appears. Use the arrow keys to change the display to match the temperature measured using the standard thermometer. Press ENTER to save.
5. The **tEMP Adj** sub-menu appears. Press RESET to return to the main display.

8.3. PROCEDURE USING DeltaV

1. Place the sensor and a calibrated reference thermometer in a container of water at ambient temperature. Be sure the temperature element in the sensor is completely submerged by keeping the sensor tip at least three inches below the water level. Stir continuously. Allow at least 20 minutes for the standard thermometer, sensor, and water to reach constant temperature.
2. Access: DeltaV Explorer/Context Menu
Standardize Temperature (method_sv_cal)
Method Steps:
 - a. Is temperature stable?: Yes; No; Abort
 - b. If yes is chosen, enter the new temperature value.

SECTION 9.0 CALIBRATION — OXYGEN

9.1 INTRODUCTION

As Figure 9-1 shows, oxygen sensors generate a current directly proportional to the concentration of dissolved oxygen in the sample. Calibrating the sensor requires exposing it to a solution containing no oxygen (zero standard) and to a solution containing a known amount of oxygen (full-scale standard).

The zero standard is necessary because oxygen sensors, even when no oxygen is present in the sample, generate a small current called the residual current. The analyzer compensates for the residual current by subtracting it from the measured current before converting the result to a dissolved oxygen value. New sensors require zeroing before being placed in service, and sensors should be zeroed whenever the electrolyte solution is replaced. The recommended zero standard is 5% sodium sulfite in water, although oxygen-free nitrogen can also be used.

The Model 499A TrDO sensor, used for the determination of trace (ppb) oxygen levels, has very low residual current and does not normally require zeroing. The residual current in the 499A TrDO sensor is equivalent to less than 0.5 ppb oxygen.

The purpose of the full-scale standard is to establish the slope of the calibration curve. Because the solubility of atmospheric oxygen in water as a function of temperature and barometric pressure is well known, the natural choice for a full-scale standard is air-saturated water. However, air-saturated water is difficult to prepare and use, so the universal practice is to use air for calibration. From the point of view of the oxygen sensor, air and air-saturated water are identical. The equivalence comes about because the sensor really measures the chemical potential of oxygen. Chemical potential is the force that causes oxygen molecules to diffuse from the sample into the sensor where they can be measured. It is also the force that causes oxygen molecules in air to dissolve in water and to continue to dissolve until the water is saturated with oxygen. Once the water is saturated, the chemical potential of oxygen in the two phases (air and water) is the same.

Oxygen sensors generate a current directly proportional to the rate at which oxygen molecules diffuse through a membrane stretched over the end of the sensor. The diffusion rate depends on the difference in chemical potential between oxygen in the sensor and oxygen in the sample. An electrochemical reaction, which destroys any oxygen molecules entering the sensor, keeps the concentration (and the chemical potential) of oxygen inside the sensor equal to zero. Therefore, the chemical potential of oxygen in the sample alone determines the diffusion rate and the sensor current.

When the sensor is calibrated, the chemical potential of oxygen in the standard determines the sensor current. Whether the sensor is calibrated in air or air-saturated water is immaterial. The chemical potential of oxygen is the same in either phase. Normally, to make the calculation of solubility in common units (like ppm DO) simpler, it is convenient to use water-saturated air for calibration.

Automatic air calibration is standard. The user simply exposes the sensor to water-saturated air and keys in the barometric pressure. The transmitter monitors the sensor current. When the current is stable, the transmitter stores the current and measures the temperature. From the temperature, the transmitter calculates the saturation vapor pressure of water. Next, it calculates the pressure of dry air by subtracting the vapor pressure from the barometric pressure. Using the fact that dry air always contains 20.95% oxygen, the transmitter calculates the partial pressure of oxygen. Once the transmitter knows the partial pressure of oxygen, it uses the Bunsen coefficient to calculate the equilibrium solubility of atmospheric oxygen in water at the prevailing temperature. At 25°C and 760 mm Hg, the equilibrium solubility is 8.24 ppm.

Often it is too difficult or messy to remove the sensor from the process liquid for calibration. In this case, the sensor can be calibrated against a measurement made with a portable laboratory instrument. The laboratory instrument typically uses a membrane-covered amperometric sensor that has been calibrated against water-saturated air.

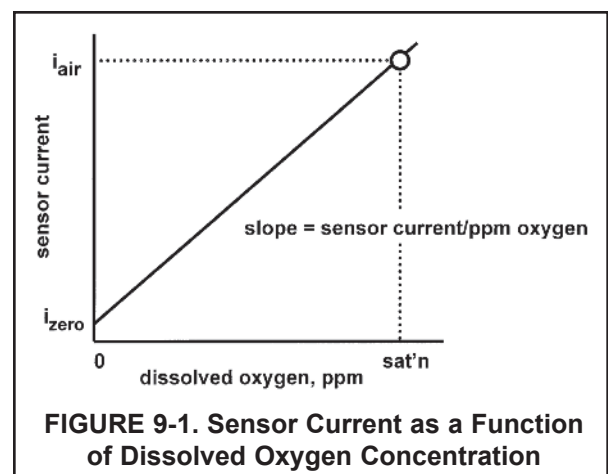

9.2 PROCEDURE — ZEROING THE SENSOR USING THE REMOTE CONTROLLER

- Place the sensor in a **fresh** solution of 5% sodium sulfite (Na_2SO_3) in water. Be sure air bubbles are not trapped against the membrane. The current will drop rapidly at first and then gradually reach a stable zero value. To monitor the sensor current, go to the main display. Press DIAG followed by NEXT. The **SenSor Cur** prompt appears. Press ENTER to view the sensor current. Note the units: nA is nanoamps; μA is microamps. The table gives typical zero values for Rosemount Analytical sensors.

Sensor	Zero Current
499ADO	<50 nA
499ATrDO	<5 nA
Hx438 and Gx448	<1 nA

A new sensor or a sensor in which the electrolyte solution has been replaced may require several hours (occasionally as long as overnight) to reach a minimum current. **DO NOT START THE ZERO ROUTINE UNTIL THE SENSOR HAS BEEN IN ZERO SOLUTION FOR AT LEAST TWO HOURS.**

- Press CAL on the remote controller.

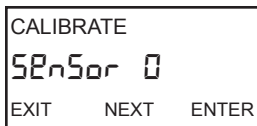

- The **SEnSor O** prompt appears. Press ENTER.

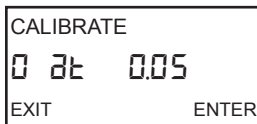

- The screen shows the value (in units selected in Section 7.5.3) below which the reading must be before the zero current will be accepted. Assume the units are ppm. The screen shows **0.02**. Therefore, the reading must be below 0.02 ppm before the zero will be accepted. For a 499ADO sensor 0.02 ppm corresponds to about 50 nA. To change the zero limit value, see Section 7.6.3. Press ENTER.

NOTE

The number shown in the main display may change. During the zero step, the previous zero current is suppressed, and the concentration shown in the main display is calculated assuming the residual current is zero. Once the transmitter accepts the new zero current, it is used in all subsequent measurements.

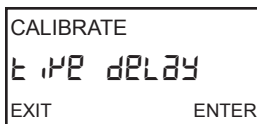

- The **tiME dELAY** message appears and remains until the zero current is below the concentration limit shown in the previous screen. If the current is already below the limit, **tiME dELAY** will not appear. To bypass the time delay, press ENTER.

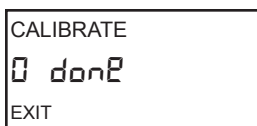

- O donE** shows that the zero step is complete. Press EXIT.

- Press RESET to return to the main display.

9.3 PROCEDURE — ZEROING THE SENSOR USING DeltaV

- Place the sensor in a **fresh** solution of 5% sodium sulfite (Na_2SO_3) in water. Be sure air bubbles are not trapped against the membrane. The current will drop rapidly at first and then gradually reach a stable zero value. To monitor the sensor current, go to the main display. Press DIAG followed by NEXT. The **SenSor Cur** prompt appears. Press ENTER to view the sensor current. Note the units: nA is nanoamps; μA is microamps. The table gives typical zero values for Rosemount Analytical sensors.

Sensor	Zero Current
499ADO	<50 nA
499ATrDO	<5 nA
Hx438 and Gx448	<1 nA

A new sensor or a sensor in which the electrolyte solution has been replaced may require several hours (occasionally as long as overnight) to reach a minimum current. **DO NOT START THE ZERO ROUTINE UNTIL THE SENSOR HAS BEEN IN ZERO SOLUTION FOR AT LEAST TWO HOURS.**

- Access: DeltaV Explorer/Context Menu
Zero Amperometric Sensor (method_sensor_zero)

Method Steps:

- Displayed: Current Oxygen Measurement

Zero limit

Is PV less than limit?: Yes; No; Abort

NOTE

Selecting “Yes” to an oxygen measurement greater than the zero limit will cause the measurement to be accepted as the zero value. Selecting “No” will cause the oxygen measurement to be re-read. The new oxygen measurement may be closer to the zero limit. If the oxygen measurement is significantly greater than the zero limit, the method should be aborted (“Abort”) and restarted after sufficient time for the oxygen reading to approach the zero limit.

- If “Yes” is chosen, the Current Oxygen Reading and the new Zero Current Value are displayed. The method then concludes.

9.4 PROCEDURE — AIR CALIBRATION USING THE INFRARED REMOTE CONTROLLER

1. Remove the sensor from the process liquid. Use a soft tissue and a stream of water from a wash bottle to clean the membrane. Blot dry. The membrane must be dry during air calibration.
2. Pour some water into a beaker and suspend the sensor with the membrane about 0.5 inch (1 cm) above the water surface. To avoid drift caused by temperature changes, keep the sensor out of the direct sun.
3. Monitor the dissolved oxygen reading and the temperature. Once readings have stopped drifting, begin the calibration. It may take 10 -15 minutes for the sensor reading in air to stabilize. Stabilization time may be even longer if the process temperature is appreciably different from the air temperature. For an accurate calibration, temperature measured by the sensor must be stable.

4. Press CAL on the remote controller.

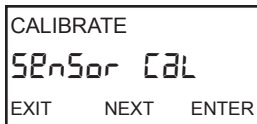

5. Press NEXT. The **SEnSor CAL** submenu appears. Press ENTER.

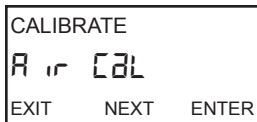

6. The **Air CAL** prompt appears. Press ENTER.



7. The screen shows the units selected for barometric pressure. Press NEXT.

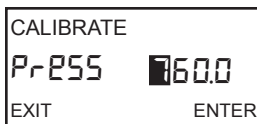

8. Use the arrow keys to enter the barometric pressure. Press ENTER.

NOTE

Be sure to enter the actual barometric pressure. Weather forecasters and airports usually report barometric pressure corrected to sea level; they do not report the actual barometric pressure. To estimate barometric pressure from altitude, see Appendix A.

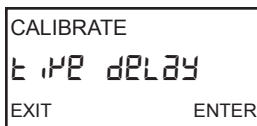

9. The **tIME dELAY** message appears and remains until the sensor reading meets the stability criteria set in Section 7.6. To bypass the time delay, press ENTER.

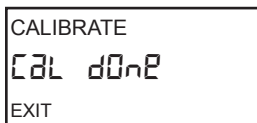

10. This screen appears when the calibration is complete. The concentration shown in the main display is the solubility of atmospheric oxygen in water at ambient temperature and barometric pressure. Press EXIT.

11. To return to the main display, press RESET.

12. During calibration, the transmitter calculates the sensitivity (nA/ppm) of the sensor. To check the sensitivity, go to the main display. Press DIAG. Press NEXT until the **SenSitivTY** (sensitivity) prompt appears. Press ENTER to display the sensitivity in nA/ppm. Typical values at 25°C are given in the table.

Sensor	nA/ppm
499ADO	1,800 - 3,100
499ATrDO	3,600 - 6,100
Hx438 and Gx448	4.8 - 9.8

9.5 PROCEDURE — AIR CALIBRATION USING DeltaV

1. Remove the sensor from the process liquid. Use a soft tissue and a stream of water from a wash bottle to clean the membrane. Blot dry. The membrane must be dry during air calibration.
2. Pour some water into a beaker and suspend the sensor with the membrane about 0.5 inch (1 cm) above the water surface. To avoid drift caused by temperature changes, keep the sensor out of the direct sun.
3. Monitor the dissolved oxygen reading and the temperature. Once readings have stopped drifting, begin the calibration. It may take 10 -15 minutes for the sensor reading in air to stabilize. Stabilization time may be even longer if the process temperature is appreciably different from the air temperature. For an accurate calibration, temperature measured by the sensor must be stable.

4. Access: DeltaV Explorer/Context Menu

Air Calibrate Oxygen Sensor (method_oxygen_air_cal)

Method Steps:

- a. Displayed: Current Oxygen Measurement
Current Temperature Measurement

Prompt: Are values stable?: Yes; No; Abort

If “No” is chosen, current values are re-read.

- b. If “Yes” is chosen:

Prompt: Select Pressure Units.

Enter desired pressure units.

- c. Prompt: Enter barometric pressure.

- d. Displayed: Current Oxygen Measurement
Current Temperature Measurement
New Sensitivity Value

Method concludes.

Typical values for sensitivity at 25C are given in the table:

Sensor	nA/ppm
499ADO	1,800 - 3,100
499ATrDO	3,600 - 6,100
Hx438 and Gx448	4.8 - 9.8

9.6 PROCEDURE — IN-PROCESS CALIBRATION USING THE REMOTE CONTROLLER

1. The transmitter and sensor can be calibrated against a standard instrument. For oxygen sensors installed in aeration basins in waste treatment plants, calibration against a second instrument is often preferred. For an accurate calibration be sure that:
 - a. The standard instrument has been zeroed and calibrated against water-saturated air following the manufacturer's instructions.
 - b. The standard sensor is inserted in the liquid as close to the process sensor as possible.
 - c. Adequate time is allowed for the standard sensor to stabilize before calibrating the process instrument.

2. Press CAL on the remote controller.

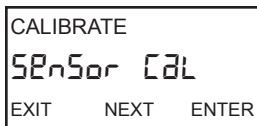

3. Press NEXT. The **SEnSor CAL** submenu appears. Press ENTER.

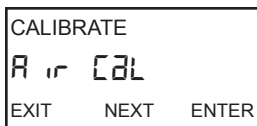

4. Press NEXT. The **Air CAL** prompt appears. Press NEXT.

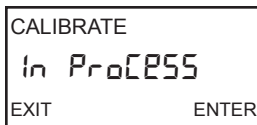

5. The **In ProCESS** prompt appears. Press ENTER.

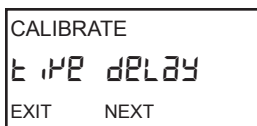

6. The **tIME dELAY** message appears and remains until the sensor reading meets the stability criteria set in Section 7.6. To bypass the time delay, press ENTER.

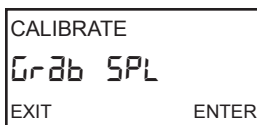

7. The **GrAb SPL** (grab sample) message appears. Press ENTER.

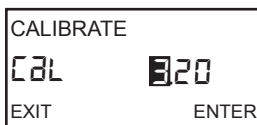

8. Use the arrow keys to change the flashing display to the value indicated by the standard instrument. Press ENTER to save.

9. Press RESET to return to the main display.

9.7 PROCEDURE — IN-PROCESS CALIBRATION USING DeltaV

1. The transmitter and sensor can be calibrated against a standard instrument. For oxygen sensors installed in aeration basins in waste treatment plants, calibration against a second instrument is often preferred. For an accurate calibration be sure that:
 - a. The standard instrument has been zeroed and calibrated against water-saturated air following the manufacturer's instructions.
 - b. The standard sensor is inserted in the liquid as close to the process sensor as possible.
 - c. Adequate time is allowed for the standard sensor to stabilize before calibrating the process instrument.
2. Access: DeltaV Explorer/Context Menu

Calibrate Amperometric Sensor (method_pv_cal)

Method Steps:

- a. Displayed: Current PV Measurement
Prompt: Is value stable?: Yes; No; Abort
If "No" is chosen, the PV measurement is re-read.
- b. If "Yes" is chosen, the PV measurement and the new sensitivity value are shown.

The method concludes.

SECTION 10.0 CALIBRATION — FREE CHLORINE

10.1 INTRODUCTION

As Figure 10-1 shows, a free chlorine sensor generates a current directly proportional to the concentration of free chlorine in the sample. Calibrating the sensor requires exposing it to a solution containing no chlorine (zero standard) and to a solution containing a known amount of chlorine (full-scale standard).

The zero standard is necessary because chlorine sensors, even when no chlorine is in the sample, generate a small current called the residual current. The transmitter compensates for the residual current by subtracting it from the measured current before converting the result to a chlorine value. New sensors require zeroing before being placed in service, and sensors should be zeroed whenever the electrolyte solution is replaced. Either of the following makes a good zero standard:

- Deionized water containing about 500 ppm sodium chloride. Dissolve 0.5 grams (1/8 teaspoonful) of table salt in 1 liter of water. **DO NOT USE DEIONIZED WATER ALONE FOR ZEROING THE SENSOR. THE CONDUCTIVITY OF THE ZERO WATER MUST BE GREATER THAN 50 μ S/cm.**
- Tap water known to contain no chlorine. Expose tap water to bright sunlight for at least 24 hours.

The purpose of the full-scale standard is to establish the slope of the calibration curve. Because stable chlorine standards do not exist, **the sensor must be calibrated against a test run on a grab sample of the process liquid.** Several manufacturers offer portable test kits for this purpose. Observe the following precautions when taking and testing the grab sample.

- Take the grab sample from a point as close to the sensor as possible. Be sure that taking the sample does not alter the flow of the sample to the sensor. It is best to install the sample tap just downstream from the sensor.
- Chlorine solutions are unstable. Run the test immediately after taking the sample. Try to calibrate the sensor when the chlorine concentration is at the upper end of the normal operating range.

Free chlorine measurements made with the 499ACL-01 sensor also require a pH correction. Free chlorine is the sum of hypochlorous acid (HOCl) and hypochlorite ion (OCl⁻). The relative amount of each depends on the pH. As pH increases, the concentration of HOCl decreases and the concentration of OCl⁻ increases. Because the sensor responds only to HOCl, a pH correction is necessary to properly convert the sensor current into a free chlorine reading.

The transmitter uses both automatic and manual pH correction. In automatic pH correction, the transmitter continuously monitors the pH of the solution and corrects the free chlorine reading for changes in pH. In manual pH correction, the transmitter uses a fixed pH value entered by the user to make the correction. Generally, if the pH changes more than about 0.2 units over short periods of time, automatic pH correction is best. If the pH is relatively steady or subject only to seasonal changes, manual pH correction is adequate.

During calibration, the transmitter must know the pH of the sample. If the transmitter is using automatic pH correction, the pH sensor (properly calibrated) **must be in the process liquid before starting the calibration.** If the transmitter is using manual pH correction, be sure to enter the pH value before starting the calibration.

The Model 499ACL-01 free chlorine sensor loses sensitivity at high concentrations of chlorine. The 5081-A transmitter has a dual slope feature that allows the user to compensate for the non-linearity of the sensor. However, for the vast majority of applications, dual slope calibration is unnecessary.

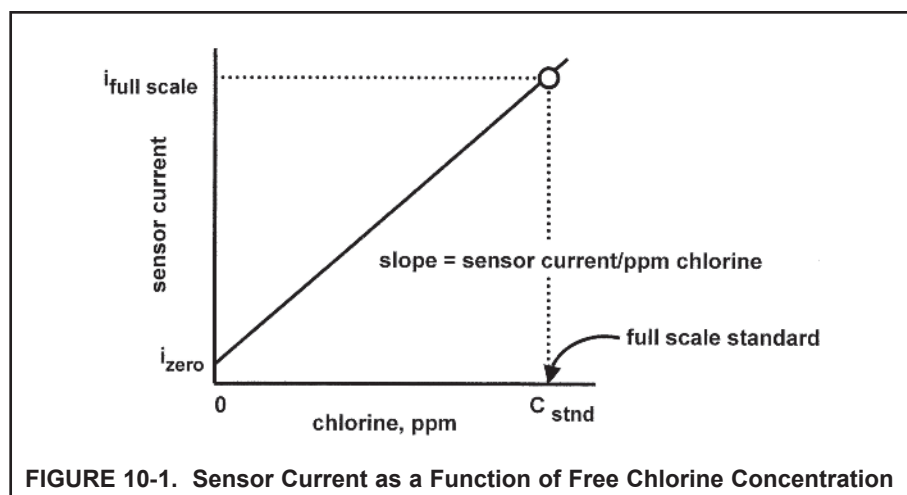

10.2 PROCEDURE — ZEROING THE SENSOR USING THE REMOTE CONTROLLER

- Place the sensor in the zero standard (see Section 10.1). Be sure no air bubbles are trapped against the membrane. The sensor current will drop rapidly at first and then gradually reach a stable zero value. To monitor the sensor current, go to the main display. Press DIAG followed by NEXT. The **SEnSor Cur** prompt appears. Press ENTER to view the sensor current. Note the units: nA is nanoamps; μ A is microamps. Typical zero current for a free chlorine sensor is -10 to +10 nanoamps.

A new sensor or a sensor in which the electrolyte solution has been replaced may require several hours (occasionally as long as overnight) to reach a minimum zero current. **DO NOT START THE ZERO ROUTINE UNTIL THE SENSOR HAS BEEN IN ZERO SOLUTION FOR AT LEAST TWO HOURS.**

- Press CAL on the remote controller.

```

CALIBRATE
SEnSor 0
EXIT  NEXT  ENTER
    
```

- The **SEnSor 0** prompt appears. Press ENTER.

```

CALIBRATE
0.02
EXIT      ENTER
    
```

- The screen shows the value (in units ppm) below which the reading must be before the zero current will be accepted. The screen shows **0.02**. Therefore, the reading must be below 0.02 ppm before the zero will be accepted. For a typical 499ACL-01 sensor, 0.02 ppm corresponds to about 7 nA. To change the zero limit value, see Section 7.6.3. Press ENTER.

NOTE

The number shown in the main display may change. During the zero step, the previous zero current is suppressed, and the concentration shown in the main display is calculated assuming the residual current is zero. Once the transmitter accepts the new zero current, it is used in all subsequent measurements.

```

CALIBRATE
tIME dELAY
EXIT      ENTER
    
```

- The **tIME dELAY** message appears and remains until the zero current is below the concentration limit shown in the previous screen. If the current is already below the limit, **tIME dELAY** will not appear. To bypass the time delay, press ENTER.

```

CALIBRATE
0 done
EXIT
    
```

- 0 done** shows that the zero step is complete. Press EXIT.

- Press RESET to return to the main display.

10.3 PROCEDURE — ZEROING THE SENSOR USING DeltaV

1. Place the sensor in the zero standard (see Section 10.1). Be sure no air bubbles are trapped against the membrane. The sensor current will drop rapidly at first and then gradually reach a stable zero value. To monitor the sensor current, go to the main display. Press DIAG followed by NEXT. The **SEnSor Cur** prompt appears. Press ENTER to view the sensor current. Note the units: nA is nanoamps; μ A is microamps. Typical zero current for a free chlorine sensor is -10 to +10 nanoamps.

A new sensor or a sensor in which the electrolyte solution has been replaced may require several hours (occasionally as long as overnight) to reach a minimum zero current. DO NOT START THE ZERO ROUTINE UNTIL THE SENSOR HAS BEEN IN ZERO SOLUTION FOR AT LEAST TWO HOURS.

2. Access: DeltaV Explorer/Context Menu

Zero Amperometric Sensor (method_sensor_zero)

Method Steps:

- a. Displayed: Current Free Chlorine Measurement

Zero limit

Prompt: Is PV less than limit?: Yes; No; Abort

NOTE

Selecting "Yes" to a free chlorine measurement greater than the zero limit will cause the measurement to be accepted as the zero value. Selecting "No" will cause the free chlorine measurement to be re-read. The new free chlorine measurement may be closer to the zero limit. If the free chlorine measurement is significantly greater than the zero limit, the method should be aborted ("Abort") and restarted after sufficient time for the free chlorine reading to approach the zero limit.

- b. If "Yes" is chosen, the Current Free Chlorine Reading and the new Zero Current Value are displayed. The method then concludes.

10.4 PROCEDURE — FULL SCALE CALIBRATION USING THE REMOTE CONTROLLER

- Place the sensor in the process liquid. If automatic pH correction is being used, calibrate the pH sensor (see Section 13.0) and place it in the process liquid. If manual pH correction is being used, measure the pH of the process liquid and enter the value (see Section 7.8). Adjust the sample flow until it is within the range recommended for the chlorine sensor. Refer to the sensor instruction sheet.
- Adjust the chlorine concentration until it is near the upper end of the control range. Wait until the reading is stable before starting the calibration.

- Press CAL on the remote controller.

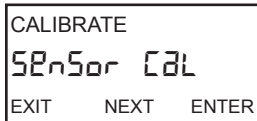

- Press NEXT. The **SEnSor CAL** submenu appears.

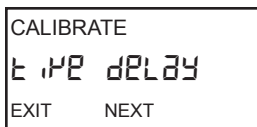

- Press ENTER. The **tIME dELAY** message appears and remains until the sensor reading meets the stability criteria set in Section 7.6. To bypass the time delay, press ENTER.

NOTE

As soon as the stability criteria are met (or ENTER is pressed to bypass the time delay), the transmitter stores the sensor current. Therefore, if the chlorine level in the process liquid drifts while the sample is being tested, there is no need to compensate for the change when entering test results in step 7.

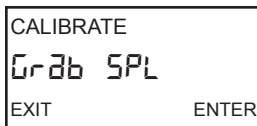

- The **GrAb SPL** (grab sample) prompt appears. Take a sample of the process liquid and immediately determine the concentration of free chlorine in the sample. Press ENTER.

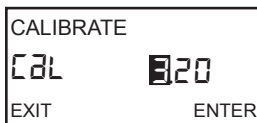

- Use the arrow keys to change the flashing display to the concentration of chlorine determined in the grab sample. Press ENTER to save.

- Press RESET to return to the main display.

- During calibration, the transmitter calculates the sensitivity (nA/ppm) of the sensor. To check the sensitivity, go to the main display. Press DIAG. Press NEXT until the **SenSitivTY** (sensitivity) prompt appears. Press ENTER to display the sensitivity in nA/ppm. The sensitivity of a 499ACL-01 sensor is 250 - 350 nA/ppm at 25°C and pH 7.

10.5 PROCEDURE — FULL SCALE CALIBRATION USING DeltaV

1. Place the sensor in the process liquid. If automatic pH correction is being used, calibrate the pH sensor (see Section 13.0) and place it in the process liquid. If manual pH correction is being used, measure the pH of the process liquid and enter the value (see Section 7.8). Adjust the sample flow until it is within the range recommended for the chlorine sensor. Refer to the sensor instruction sheet.
2. Adjust the chlorine concentration until it is near the upper end of the control range. Wait until the reading is stable before starting the calibration.
3. Access: DeltaV Explorer/Context Menu

Calibrate Amperometric Sensor (method_pv_cal)

Method Steps:

- a. Displayed: Current PV Measurement

Prompt: Is value stable?: Yes; No; Abort

If "No" is chosen, the PV measurement is re-read.

- b. If "Yes" is chosen, the PV measurement and the new sensitivity value are shown.

The method concludes.

10.6 DUAL SLOPE CALIBRATION

Figure 10-2 show the principle of dual slope calibration. Between zero and concentration C1, the sensor response is linear. When the concentration of chlorine becomes greater than C1, the response is non-linear. In spite of the non-linearity, the response can be approximated by a straight line between point 1 and point 2.

Dual slope calibration is rarely needed. It is probably useful in fewer than 5% of applications.

1. Be sure the transmitter has been configured for dual slope calibration. See Section 7.6.
2. Zero the sensor. See Section 10.2.
3. Place the sensor in the process liquid. If automatic pH correction is being used, calibrate the pH sensor (Section 13.0) and place it in the process liquid. If manual pH correction is being used, measure the pH of the process liquid and enter the value. See Section 7.8. Adjust the sample flow until it is within the range recommended for the chlorine sensor. Refer to the sensor instruction sheet.

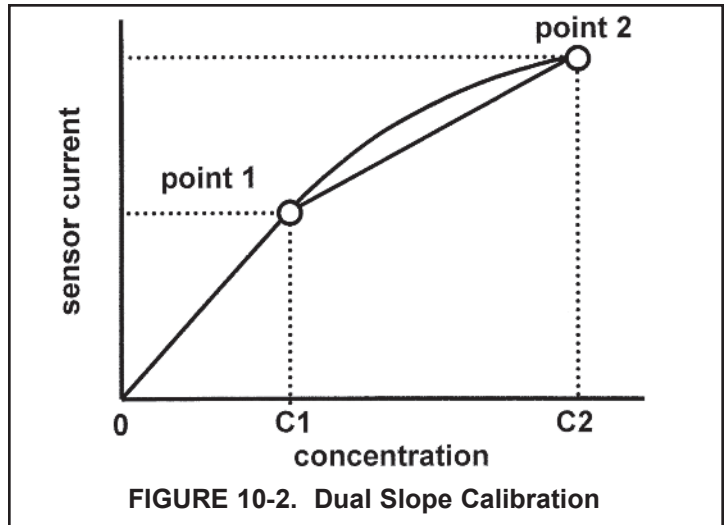

4. Press CAL on the remote controller. Press NEXT.

```

CALIBRATE
SEnSor CAL
EXIT  NEXT  ENTER
    
```

5. The **SEnSor CAL** prompt appears. Press ENTER.

```

CALIBRATE
CAL Pt 1
EXIT  NEXT  ENTER
    
```

6. The **CAL Pt 1** prompt appears. Adjust the chlorine concentration until it is near the upper end of the linear range of the sensor. Press ENTER.

```

CALIBRATE
tiME dELAY
EXIT  NEXT
    
```

7. The **tiME dELAY** message appears and remains until the sensor reading meets the stability criteria set in Section 7.6. To bypass the time delay, press ENTER.

NOTE

As soon as the stability criteria are met (or ENTER is pressed to by-pass the time delay), the transmitter stores the sensor current. Therefore, if the chlorine level in the process liquid drifts while the sample is being tested, there is no need to compensate for the change when entering test results.

```

CALIBRATE
GrAb SPL
EXIT  ENTER
    
```

8. The **GrAb SPL** (grab sample) prompt appears. Take a sample of the process liquid and immediately determine the concentration of free chlorine in the sample. Press ENTER.

```

CALIBRATE
Pt 1  6.00
EXIT      ENTER
    
```

9. The **Pt1** prompt appears. Use the arrow keys to change the flashing display to the concentration of chlorine determined in the grab sample. Press ENTER to save.

```

CALIBRATE
CAL Pt 2
EXIT  NEXT  ENTER
    
```

10. The **CAL Pt 2** prompt appears. Adjust the concentration of chlorine until it is near the top end of the range, i.e., near concentration C2 shown in Figure 10-2. Press ENTER.

```

CALIBRATE
t i M E d E L A Y
EXIT  NEXT
    
```

11. The **tiME dELAY** message appears and remains until the sensor reading meets the stability criteria set in Section 7.6. To bypass the time delay, press ENTER.

```

CALIBRATE
GrAb SPL
EXIT      ENTER
    
```

12. The **GrAb SPL** (grab sample) prompt appears. Take a sample of the process liquid and immediately determine the concentration of free chlorine in the sample. Press ENTER.

```

CALIBRATE
Pt 2  6.00
EXIT      ENTER
    
```

13. The **Pt2** prompt appears. Use the arrow keys to change the flashing display to the concentration of chlorine determined in the grab sample. Press ENTER to save.

14. Press RESET to return to the main display.

SECTION 11.0 CALIBRATION — TOTAL CHLORINE

11.1 INTRODUCTION

Total chlorine is the sum of free and combined chlorine. The continuous determination of total chlorine requires two steps. See Figure 11-1. First, the sample flows into a conditioning system (SCS 921) where a pump continuously adds acetic acid and potassium iodide to the sample. The acid lowers the pH, which allows total chlorine in the sample to quantitatively oxidize the iodide in the reagent to iodine. In the second step, the treated sample flows to the sensor. The sensor is a membrane-covered amperometric sensor, whose output is proportional to the concentration of iodine. Because the concentration of iodine is proportional to the concentration of total chlorine, the analyzer can be calibrated to read total chlorine.

Figure 11-2 shows a typical calibration curve for a total chlorine sensor. Because the sensor really measures iodine, calibrating the sensor requires exposing it to a solution containing no iodine (zero standard) and to a solution containing a known amount of iodine (full-scale standard).

The zero standard is necessary because the sensor, even when no iodine is present, generates a small current called the residual current. The transmitter compensates for the residual current by subtracting it from the measured current before converting the result to a total chlorine value. New sensors require zeroing before being placed in service, and sensors should be zeroed whenever the electrolyte solution is replaced. The best zero standard is sample without reagent added.

The purpose of the full-scale standard is to establish the slope of the calibration curve. Because stable total chlorine standards do not exist, **the sensor must be calibrated against a test run on a grab sample of the process liquid.** Several manufacturers offer portable test kits for this purpose. Observe the following precautions when taking and testing the grab sample.

- Take the grab sample from a point as close as possible to the inlet of the SCS921 sample conditioning system. Be sure that taking the sample does not alter the flow through the SCS921. Sample flow must remain between 80 and 100 mL/min.
- Chlorine solutions are unstable. Run the test immediately after taking the sample. Try to calibrate the sensor when the chlorine concentration is at the upper end of the normal operating range.

The Model 499ACL-02 (total chlorine) sensor loses sensitivity at high concentrations of chlorine. The 5081-A transmitter has a dual slope feature that allows the user to compensate for the non-linearity of the sensor. However, for the vast majority of applications, dual slope calibration is unnecessary.

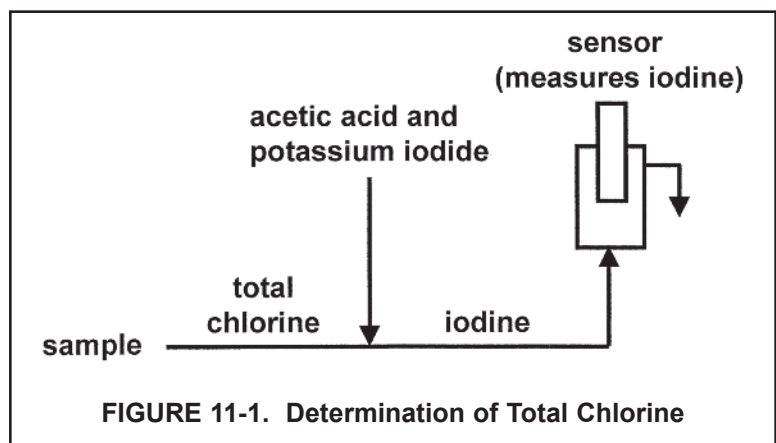

FIGURE 11-1. Determination of Total Chlorine

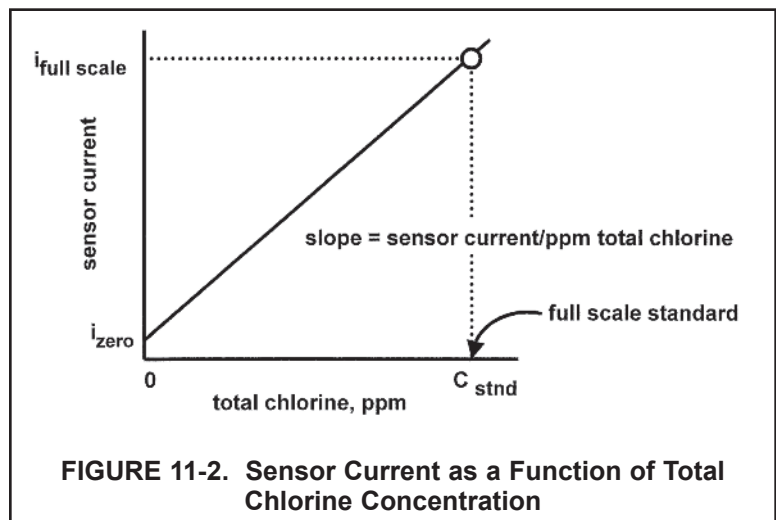

FIGURE 11-2. Sensor Current as a Function of Total Chlorine Concentration

11.2 PROCEDURE — ZEROING THE SENSOR USING THE REMOTE CONTROLLER

1. Complete the startup sequence described in the SCS921 instruction manual. Adjust the sample flow to between 80 and 100 mL/min, and set the sample pressure to between 3 and 5 psig.
2. Remove the reagent uptake tube from the reagent bottle and let it dangle in air. The peristaltic pump will simply pump air into the sample.
3. Let the system run until the sensor current is stable. The current will drop rapidly at first and then gradually reach a stable value. To monitor the sensor current, go to the main display. Press DIAG followed by NEXT. The **SEnSor Cur** prompt appears. Press ENTER to view the sensor current. Note the units: nA is nanoamps; μ A is microamps. Typical zero current for a total chlorine sensor is -10 to +30 nanoamps.

A new sensor or a sensor in which the electrolyte solution has been replaced may require several hours (occasionally as long as overnight) to reach a minimum zero current. DO NOT START THE ZERO ROUTINE UNTIL THE SENSOR HAS BEEN IN ZERO SOLUTION FOR AT LEAST TWO HOURS.

4. Press CAL on the remote controller.

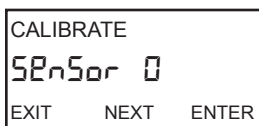

5. The **SEnSor 0** prompt appears. Press ENTER.

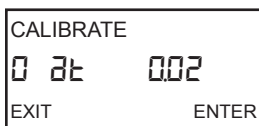

6. The screen shows the value (in units ppm) below which the reading must be before the zero current will be accepted. The screen shows **0.02**. Therefore, the reading must be below 0.02 ppm before the zero will be accepted. For a typical 499ACL-02 sensor, 0.02 ppm corresponds to about 20 nA. To change the zero limit value, see Section 7.6.3. Press ENTER.

NOTE

The number shown in the main display may change. During the zero step, the previous zero current is suppressed, and the concentration shown in the main display is calculated assuming the residual current is zero. Once the transmitter accepts the new zero current, it is used in all subsequent measurements.

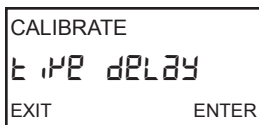

7. The **tiME dELAY** message appears and remains until the zero current is below the concentration limit shown in the previous screen. If the current is already below the limit, **tiME dELAY** will not appear. To bypass the time delay, press ENTER.

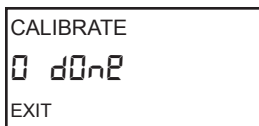

8. **0 donE** shows that the zero step is complete. Press EXIT.
9. Press RESET to return to the main display.

11.3 PROCEDURE — ZEROING THE SENSOR USING DeltaV

1. Complete the startup sequence described in the SCS921 instruction manual. Adjust the sample flow to between 80 and 100 mL/min, and set the sample pressure to between 3 and 5 psig.
2. Remove the reagent uptake tube from the reagent bottle and let it dangle in air. The peristaltic pump will simply pump air into the sample.
3. Let the system run until the sensor current is stable. The current will drop rapidly at first and then gradually reach a stable value. To monitor the sensor current, go to the main display. Press DIAG followed by NEXT. The **SEnSor Cur** prompt appears. Press ENTER to view the sensor current. Note the units: nA is nanoamps; μ A is microamps. Typical zero current for a total chlorine sensor is -10 to +30 nanoamps.

A new sensor or a sensor in which the electrolyte solution has been replaced may require several hours (occasionally as long as overnight) to reach a minimum zero current. DO NOT START THE ZERO ROUTINE UNTIL THE SENSOR HAS BEEN IN ZERO SOLUTION FOR AT LEAST TWO HOURS.

4. Access: DeltaV Explorer/Context Menu

Zero Amperometric Sensor (method_sensor_zero)

Method Steps:

- a. Displayed: Current Total Chlorine Measurement

Zero limit

Prompt: Is PV less than limit?: Yes; No; Abort

NOTE

Selecting "Yes" to a total chlorine measurement greater than the zero limit will cause the measurement to be accepted as the zero value. Selecting "No" will cause the total chlorine measurement to be re-read. The new total chlorine measurement may be closer to the zero limit. If the total chlorine measurement is significantly greater than the zero limit, the method should be aborted ("Abort") and restarted after sufficient time for the total chlorine reading to approach the zero limit.

- b. If "Yes" is chosen, the Current Total Chlorine Reading and the new Zero Current Value are displayed. The method then concludes.

11.4 PROCEDURE — FULL SCALE CALIBRATION USING THE REMOTE CONTROLLER

1. If the sensor was just zeroed, place the reagent uptake tube back in the bottle. Once the flow of reagent starts, it takes about one minute for the sensor current to begin to increase. It may take an hour or longer for the reading to stabilize. Be sure the sample flow stays between 80 and 100 mL/min and the pressure is between 3 and 5 psig.
2. Adjust the chlorine concentration until it is near the upper end of the control range. Wait until the controller reading is stable before starting the calibration.

3. Press CAL on the remote controller.

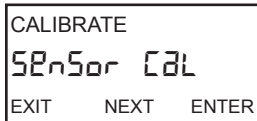

4. Press NEXT. The **SEnSor CAL** submenu appears.

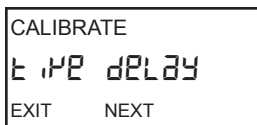

5. Press NEXT. The **tIME dELAY** message appears and remains until the sensor reading meets the stability criteria set in Section 7.6. To bypass the time delay, press ENTER.

NOTE

As soon as the stability criteria are met (or ENTER is pressed to bypass the time delay), the transmitter stores the sensor current. Therefore, if the chlorine level in the process liquid drifts while the sample is being tested, there is no need to compensate for the change when entering test results in step 7.

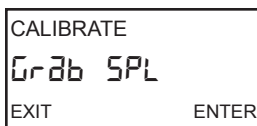

6. The **GrAb SPL** (grab sample) prompt appears. Take a sample of the process liquid and immediately determine the concentration of total chlorine in the sample. Press ENTER.

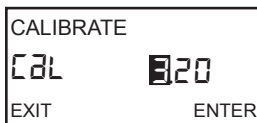

7. Use the arrow keys to change the flashing display to the concentration of chlorine determined in the grab sample. Press ENTER to save.

8. Press RESET to return to the main display.

9. During calibration, the transmitter calculates the sensitivity (nA/ppm) of the sensor. To check the sensitivity, go to the main display. Press DIAG. Press NEXT until the **SenSitivity** (sensitivity) prompt appears. Press ENTER to display the sensitivity in nA/ppm. The sensitivity of a 499ACL-02 sensor is about 1300 nA/ppm at 25°C.

11.5 PROCEDURE — FULL SCALE CALIBRATION USING DeltaV

1. If the sensor was just zeroed, place the reagent uptake tube back in the bottle. Once the flow of reagent starts, it takes about one minute for the sensor current to begin to increase. It may take an hour or longer for the reading to stabilize. Be sure the sample flow stays between 80 and 100 mL/min and the pressure is between 3 and 5 psig.
2. Adjust the chlorine concentration until it is near the upper end of the control range. Wait until the controller reading is stable before starting the calibration.
3. Access: DeltaV Explorer/Context Menu

Calibrate Amperometric Sensor (method_pv_cal)

Method Steps:

- a. Displayed: Current PV Measurement

Prompt: Is value stable?: Yes; No; Abort

If "No" is chosen, the PV measurement is re-read.

- b. If "Yes" is chosen, the PV measurement and the new sensitivity value are shown.

The method concludes.

11.6 DUAL SLOPE CALIBRATION

Figure 11-3 show the principle of dual slope calibration. Between zero and concentration C1, the sensor response is linear. When the concentration of chlorine becomes greater than C1, the response is non-linear. In spite of the non-linearity, the response can be approximated by a straight line between point 1 and point 2.

Dual slope calibration is rarely needed. It is probably useful in fewer than 5% of applications.

1. Be sure the transmitter has been configured for dual slope calibration. See Section 7.6.
2. Zero the sensor. See Section 11.2.
3. Place the sensor in the process liquid. If automatic pH correction is being used, calibrate the pH sensor (Section 13.0) and place it in the process liquid. If manual pH correction is being used, measure the pH of the process liquid and enter the value. See Section 7.8. Adjust the sample flow until it is within the range recommended for the chlorine sensor. Refer to the sensor instruction sheet.

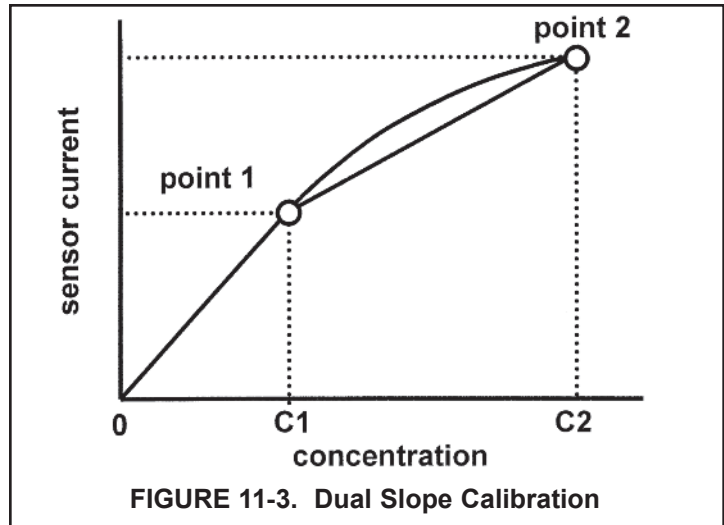

4. Press CAL on the remote controller. Press NEXT.

```

CALIBRATE
SEnSor CAL
EXIT  NEXT  ENTER
    
```

5. The **SEnSor CAL** prompt appears. Press ENTER.

```

CALIBRATE
CAL Pt 1
EXIT  NEXT  ENTER
    
```

6. The **CAL Pt 1** prompt appears. Adjust the chlorine concentration until it is near the upper end of the linear range of the sensor. Press ENTER.

```

CALIBRATE
tIME dELAY
EXIT  NEXT
    
```

7. The **tIME dELAY** message appears and remains until the sensor reading meets the stability criteria set in Section 7.6. To bypass the time delay, press ENTER.

NOTE

As soon as the stability criteria are met (or ENTER is pressed to by-pass the time delay), the transmitter stores the sensor current. Therefore, if the chlorine level in the process liquid drifts while the sample is being tested, there is no need to compensate for the change when entering test results.

```

CALIBRATE
GrAb SPL
EXIT  ENTER
    
```

8. The **GrAb SPL** (grab sample) prompt appears. Take a sample of the process liquid and immediately determine the concentration of total chlorine in the sample. Press ENTER.

```

CALIBRATE
Pt 1  8.00
EXIT      ENTER
    
```

9. The **Pt1** prompt appears. Use the arrow keys to change the flashing display to the concentration of chlorine determined in the grab sample. Press ENTER to save.

```

CALIBRATE
CAL Pt 2
EXIT  NEXT  ENTER
    
```

10. The **CAL Pt 2** prompt appears. Adjust the concentration of chlorine until it is near the top end of the range, i.e., near concentration C2 shown in Figure 11-3. Press ENTER.

```

CALIBRATE
TIME DELAY
EXIT  NEXT
    
```

11. The **tiME dELAY** message appears and remains until the sensor reading meets the stability criteria set in Section 7.6. To bypass the time delay, press ENTER.

```

CALIBRATE
GrAb SPL
EXIT      ENTER
    
```

12. The **GrAb SPL** (grab sample) prompt appears. Take a sample of the process liquid and immediately determine the concentration of total chlorine in the sample. Press ENTER.

```

CALIBRATE
Pt 2  8.00
EXIT      ENTER
    
```

13. The **Pt2** prompt appears. Use the arrow keys to change the flashing display to the concentration of chlorine determined in the grab sample. Press ENTER to save.

14. Press RESET to return to the main display.

SECTION 12.0 CALIBRATION — OZONE

12.1 INTRODUCTION

As Figure 12-1 shows, an ozone sensor generates a current directly proportional to the concentration of ozone in the sample. Calibrating the sensor requires exposing it to a solution containing no ozone (zero standard) and to a solution containing a known amount of ozone (full-scale standard).

The zero standard is necessary because ozone sensors, even when no ozone is in the sample, generate a small current called the residual current. The transmitter compensates for the residual current by subtracting it from the measured current before converting the result to an ozone value. New sensors require zeroing before being placed in service, and sensors should be zeroed whenever the electrolyte solution is replaced. Either of the following makes a good zero standard:

- Deionized water.
- Tap water known to contain no ozone. Expose tap water to ozone-free air for several hours.

The purpose of the full-scale standard is to establish the slope of the calibration curve. Because stable ozone standards do not exist, **the sensor must be calibrated against a test run on a grab sample of the process liquid.** Several manufacturers offer portable test kits for this purpose. Observe the following precautions when taking and testing the grab sample.

- Take the grab sample from a point as close to the sensor as possible. Be sure that taking the sample does not alter the flow of the sample to the sensor. It is best to install the sample tap just downstream from the sensor.
- Ozone solutions are unstable. Run the test immediately after taking the sample. Try to calibrate the sensor when the ozone concentration is at the upper end of the normal operating range.

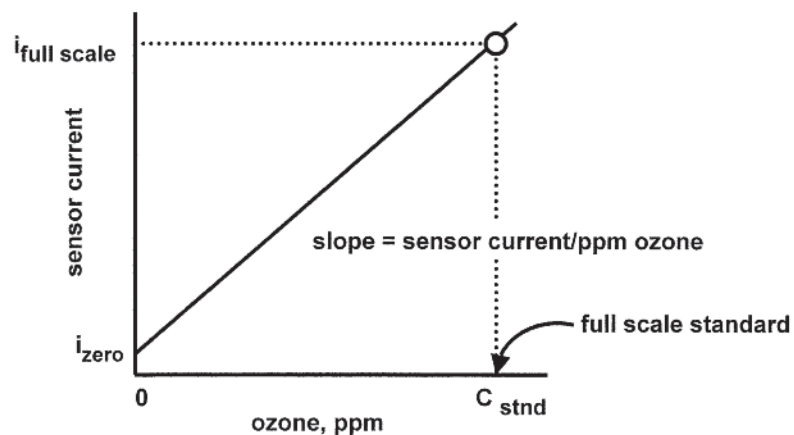

FIGURE 12-1. Sensor Current as a Function of Ozone Concentration

12.2 PROCEDURE — ZEROING THE SENSOR USING THE REMOTE CONTROLLER

- Place the sensor in the zero standard (see Section 12.1). Be sure no air bubbles are trapped against the membrane. The sensor current will drop rapidly at first and then gradually reach a stable zero value. To monitor the sensor current, go to the main display. Press DIAG followed by NEXT. The **SEnSor Cur** prompt appears. Press ENTER to view the sensor current. Note the units: nA is nanoamps; μ A is microamps. Typical zero current for an ozone sensor is -10 to +10 nanoamps.

A new sensor or a sensor in which the electrolyte solution has been replaced may require several hours (occasionally as long as overnight) to reach a minimum zero current. **DO NOT START THE ZERO ROUTINE UNTIL THE SENSOR HAS BEEN IN ZERO SOLUTION FOR AT LEAST TWO HOURS.**

- Press CAL on the remote controller.

```

CALIBRATE
SEnSor 0
EXIT  NEXT  ENTER
    
```

- The **SEnSor O** prompt appears. Press ENTER.

```

CALIBRATE
0 at 002
EXIT          ENTER
    
```

- The screen shows the value (in units ppm) below which the reading must be before the zero current will be accepted. The screen shows **0.02**. Therefore, the reading must be below 0.02 ppm before the zero will be accepted. For a typical ozone sensor, 0.02 ppm corresponds to about 7 nA. To change the zero limit value, see Section 7.6.3. Press ENTER.

NOTE

The number shown in the main display may change. During the zero step, the previous zero current is suppressed, and the concentration shown in the main display is calculated assuming the residual current is zero. Once the transmitter accepts the new zero current, it is used in all subsequent measurements.

```

CALIBRATE
t iME dELAY
EXIT          ENTER
    
```

- The **tiME dELAY** message appears and remains until the zero current is below the concentration limit shown in the previous screen. If the current is already below the limit, **tiME dELAY** will not appear. To bypass the time delay, press ENTER.

```

CALIBRATE
0 done
EXIT
    
```

- O donE** shows that the zero step is complete. Press EXIT.

- Press RESET to return to the main display.

12.3 PROCEDURE — ZEROING THE SENSOR USING DeltaV

- Place the sensor in the zero standard (see Section 12.1). Be sure no air bubbles are trapped against the membrane. The sensor current will drop rapidly at first and then gradually reach a stable zero value. To monitor the sensor current, go to the main display. Press DIAG followed by NEXT. The **SEnSor Cur** prompt appears. Press ENTER to view the sensor current. Note the units: nA is nanoamps; µA is microamps. Typical zero current for an ozone sensor is -10 to +10 nanoamps.

A new sensor or a sensor in which the electrolyte solution has been replaced may require several hours (occasionally as long as overnight) to reach a minimum zero current. **DO NOT START THE ZERO ROUTINE UNTIL THE SENSOR HAS BEEN IN ZERO SOLUTION FOR AT LEAST TWO HOURS.**

- Access: DeltaV Explorer/Context Menu
Zero Amperometric Sensor (method_sensor_zero)

Method Steps:

- Displayed: Current Ozone Measurement
Zero limit
Prompt: Is PV less than limit?: Yes; No; Abort

NOTE

Selecting “Yes” to a ozone measurement greater than the zero limit will cause the measurement to be accepted as the zero value. Selecting “No” will cause the ozone measurement to be re-read. The new ozone measurement may be closer to the zero limit. If the ozone measurement is significantly greater than the zero limit, the method should be aborted (“Abort”) and restarted after sufficient time for the ozone reading to approach the zero limit.

- If “Yes” is chosen, the Current Ozone Reading and the new Zero Current Value are displayed. The method then concludes.

12.4 PROCEDURE — FULL SCALE CALIBRATION USING THE REMOTE CONTROLLER

- Place the sensor in the process liquid. Adjust the sample flow until it is within the range recommended for the sensor. Refer to the sensor instruction sheet.
- Adjust the ozone concentration until it is near the upper end of the control range. Wait until the reading is stable before starting the calibration.

- Press CAL on the infrared remote controller.

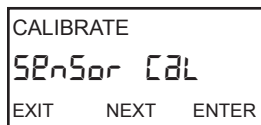

- Press NEXT. The **SEnSor CAL** submenu appears.

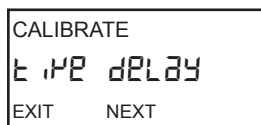

- Press NEXT. The **tiME dELAY** message appears and remains until the sensor reading meets the stability criteria set in Section 7.6. To bypass the time delay, press ENTER.

NOTE

As soon as the stability criteria are met (or ENTER is pressed to bypass the time delay), the transmitter stores the sensor current. Therefore, if the chlorine level in the process liquid drifts while the sample is being tested, there is no need to compensate for the change when entering test results in step 7.

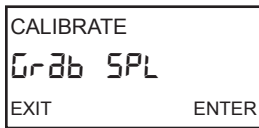

6. The **GrAb SPL** (grab sample) prompt appears. Take a sample of the process liquid and immediately determine the concentration of ozone in the sample. Press ENTER.



7. Use the arrow keys to change the flashing display to the concentration of ozone determined in the grab sample. Press ENTER to save.

8. Press RESET to return to the main display.

9. During calibration, the transmitter calculates the sensitivity (nA/ppm) of the sensor. To check the sensitivity, go to the main display. Press DIAG. Press NEXT until the **SenSitivtY** (sensitivity) prompt appears. Press ENTER to display the sensitivity in nA/ppm. The sensitivity of a 499AOZ sensor is about 350 nA/ppm at 25°C.

12.5 PROCEDURE — FULL SCALE CALIBRATION USING DeltaV

1. Place the sensor in the process liquid. Adjust the sample flow until it is within the range recommended for the sensor. Refer to the sensor instruction sheet.
2. Adjust the ozone concentration until it is near the upper end of the control range. Wait until the reading is stable before starting the calibration.
3. Access: DeltaV Explorer/Context Menu

Calibrate Amperometric Sensor (method_pv_cal)

Method Steps:

- a. Displayed: Current PV Measurement
 Prompt: Is value stable?: Yes; No; Abort
 If "No" is chosen, the PV measurement is re-read.
- b. If "Yes" is chosen, the PV measurement and the new sensitivity value are shown.

The method concludes.

SECTION 13.0 CALIBRATION — pH

13.1 INTRODUCTION

A new pH sensor must be calibrated before use. Regular recalibration is also necessary.

A pH measurement cell (pH sensor and the solution to be measured) can be pictured as a battery with an extremely high internal resistance. The voltage of the battery depends on the pH of the solution. The pH meter, which is basically a voltmeter with a very high input impedance, measures the cell voltage and calculates pH using a conversion factor. The value of the voltage-to-pH conversion factor depends on the sensitivity of the pH sensing element (and the temperature). The sensing element is a thin, glass membrane at the end of the sensor. As the glass membrane ages, the sensitivity drops. Regular recalibration corrects for the loss of sensitivity. pH calibration standards, also called buffers, are readily available.

Two-point calibration is standard. Both automatic calibration and manual calibration are available. Auto calibration avoids common pitfalls and reduces errors. Its use is recommended.

In automatic calibration the transmitter recognizes the buffer and uses temperature-corrected pH values in the calibration. The table below lists the standard buffers the controller recognizes. The transmitter also recognizes several technical buffers: Merck, Ingold, and DIN 19267. Temperature-pH data stored in the controller are valid between at least 0 and 60°C.

pH at 25°C (nominal pH)	Standard(s)
1.68	NIST, DIN 19266, JSI 8802, BSI (see note 1)
3.56	NIST, BSI
3.78	NIST
4.01	NIST, DIN 19266, JSI 8802, BSI
6.86	NIST, DIN 19266, JSI 8802, BSI
7.00	(see note 2)
7.41	NIST
9.18	NIST, DIN 19266, JSI 8802, BSI
10.01	NIST, JSI 8802, BSI
12.45	NIST, DIN 19266

Note 1: NIST is National Institute of Standards, DIN is Deutsche Institute für Normung, JSI is Japan Standards Institute, and BSI is British Standards Institute.

Note 2: pH 7 buffer is not a standard buffer. It is a popular commercial buffer in the United States.

During automatic calibration, the controller also measures noise and drift and does not accept calibration data until readings are stable. Calibration data will be accepted as soon as the pH reading is constant to within the factory-set limits of 0.02 pH units for 10 seconds. The stability settings can be changed. See Section 7.8.

In manual calibration, the user judges when pH readings are stable. He also has to look up the pH of the buffer at the temperature it is being used and enter the value in the transmitter.

Once the transmitter completes the calibration, it calculates the calibration slope and offset. The slope is reported as the slope at 25°C. Figure 13-1 defines the terms.

The transmitter can also be standardized. Standardization is the process of forcing the transmitter reading to match the reading from a second pH instrument. Standardization is sometimes called a one-point calibration.

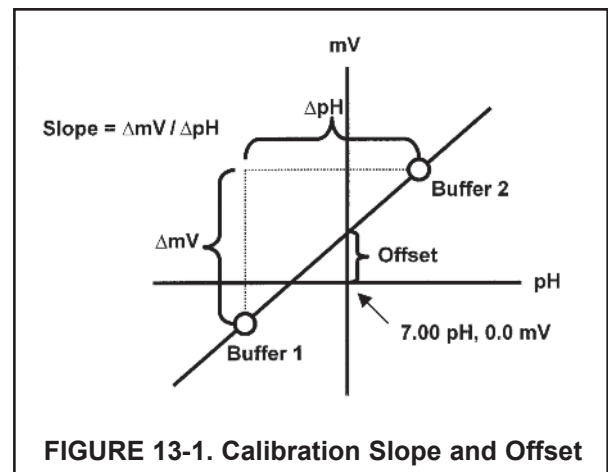
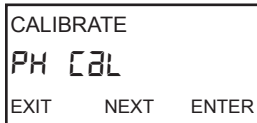

FIGURE 13-1. Calibration Slope and Offset

13.2 PROCEDURE — AUTO CALIBRATION USING THE REMOTE CONTROLLER

1. Verify that auto calibration has been enabled. See Section 7.8.
2. Obtain two buffer solutions. Ideally, the buffer pH values should bracket the range of pH values to be measured.
3. Remove the sensor from the process liquid. If the temperature of the process and buffer are appreciably different, place the sensor in a container of tap water at the buffer temperature. Do not start the calibration until the sensor has reached the buffer temperature. Thirty minutes is usually adequate.

4. Press CAL on the remote controller.



5. Press NEXT until the **PH CAL** submenu appears. Press ENTER.

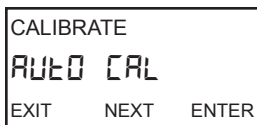

6. The **AUTO CAL** submenu appears. Press ENTER.

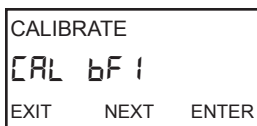

7. The **CAL bf1** prompt appears. Rinse the sensor and place it in the first buffer. Be sure the glass bulb and reference junction are completely submerged. Swirl the sensor. The main display will show the pH of the buffer based on the previous calibration. Press ENTER.

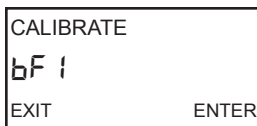

8. **bf1** flashes until the pH reading meets the stability criteria programmed in Section 7.8.

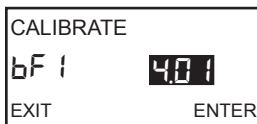

9. Once the reading is stable, the display changes to look like the figure at left. The flashing number is the nominal pH, that is, the pH of the buffer at 25°C. If the flashing number does not match the nominal pH, press **▲** or **▼** until the correct pH appears. Press ENTER to save.

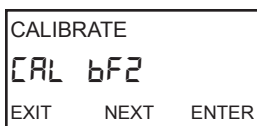

10. The **CAL bf2** prompt appears. Remove the sensor from the first buffer. Rinse the sensor and place it in the second buffer. Be sure the glass bulb and reference junction are completely submerged. Swirl the sensor. The display will show the pH of the buffer based on the previous calibration. Press ENTER.

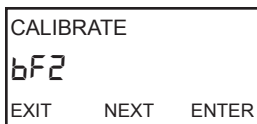

11. **bf2** flashes until the pH reading meets the stability criteria programmed in Section 7.8.

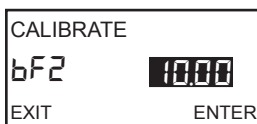

12. Once the reading is stable, the display changes to look like the figure at left. The flashing number is the nominal pH, that is, the pH of the buffer at 25°C. If the flashing number does not match the nominal pH, press **▲** or **▼** until the correct pH appears. Press ENTER to save.

13. Press RESET to return to the main display.

13.3 PROCEDURE — AUTO CALIBRATION USING DeltaV

1. Verify that auto calibration has been enabled. See Section 7.8.
2. Obtain two buffer solutions. Ideally, the buffer pH values should bracket the range of pH values to be measured.
3. Remove the sensor from the process liquid. If the temperature of the process and buffer are appreciably different, place the sensor in a container of tap water at the buffer temperature. Do not start the calibration until the sensor has reached the buffer temperature. Thirty minutes is usually adequate.
4. Access: DeltaV Explorer/Context Menu
pH Buffer Calibration (method_ph_buffer_cal)

NOTE

For automatic buffer calibration to occur, the parameter Buffer Standard (BUFFER_STANDARD) must be set to a buffer standard, and not "Manual".

Method Steps:

- a. Prompt: Place sensor in buffer 1.
- b. Displayed: Current pH Measurement
Current Temperature Measurement
Message: Waiting for pH input to stabilize.
- c. Displayed: Current pH Measurement
Current Temperature Measurement
Prompt: Is buffer = x.xx pH?: Yes; Next Buffer; Previous Buffer
Use the next or previous buffer buttons to choose the Buffer 1 value being used.
Select "Yes" when that buffer value is reached.
- d. Prompt: Place sensor in buffer 2.
- e. Displayed: Current pH Measurement
Current Temperature Measurement
Message: Waiting for pH input to stabilize.
- f. Displayed: Current pH Measurement
Current Temperature Measurement
Prompt: Is buffer = y.yy pH?: Yes; Next Buffer; Previous Buffer
Use the next or previous buffer buttons to choose the Buffer 2 value being used.
Select "Yes" when that buffer value is reached.
- g. If there are calibration errors, they will be displayed, and the corresponding errors will be shown in DeltaV Explorer/Status/Errors Tab.
- h. Displayed: Current pH Measurement
Current Temperature Measurement
New pH Slope Value
New pH Zero Offset Value

The method concludes.

13.4 PROCEDURE — MANUAL CALIBRATION USING THE REMOTE CONTROLLER

1. Verify that manual calibration has been enabled. See Section 7.8.
2. Obtain two buffer solutions. Ideally, the buffer pH values should bracket the range of pH values to be measured. Also obtain a reliable thermometer.
3. Remove the sensor from the process liquid. If the temperature of the process and buffer are appreciably different, place the sensor in a container of tap water at the buffer temperature. Do not start the calibration until the sensor has reached the buffer temperature. Thirty minutes is usually adequate.

4. Press CAL on the remote controller.

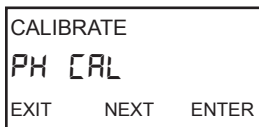

5. Press NEXT until the **PH CAL** prompt appears. Press ENTER.



6. The **MAn CAL** message appears. Press ENTER.

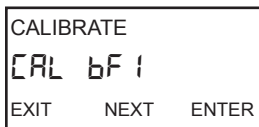

7. The **CAL bF1** prompt appears. Rinse the sensor and the thermometer and place them in the first buffer. Be sure the glass bulb and reference junction are completely submerged. Swirl the sensor. The main display will show the pH of the buffer based on the previous calibration. Press ENTER.

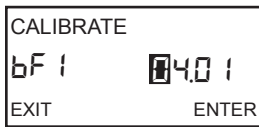

8. Wait until the pH reading in the main display is constant. Use the arrow keys to change the flashing display to the value of the buffer at the measurement temperature. Press ENTER.

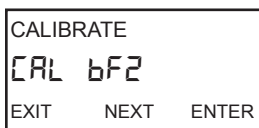

9. The **CAL bF2** prompt appears. Rinse the sensor and the thermometer and place them in the second buffer. Be sure the glass bulb and reference junction are completely submerged. Swirl the sensor. The main display will show the pH of the buffer based on the previous calibration. Press ENTER.

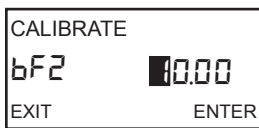

10. Wait until the pH reading in the main display is constant. Use the arrow keys to change the flashing display to the value of the buffer at the measurement temperature. Press ENTER.

11. Press RESET to return to the main display.

13.5 PROCEDURE — MANUAL CALIBRATION USING DeltaV

1. Verify that manual calibration has been enabled. See Section 7.8.
2. Obtain two buffer solutions. Ideally, the buffer pH values should bracket the range of pH values to be measured. Also obtain a reliable thermometer.
3. Remove the sensor from the process liquid. If the temperature of the process and buffer are appreciably different, place the sensor in a container of tap water at the buffer temperature. Do not start the calibration until the sensor has reached the buffer temperature. Thirty minutes is usually adequate.
4. Access: DeltaV Explorer/Context Menu
pH Buffer Calibration (method_ph_buffer_cal)

NOTE

For manual buffer calibration to occur, the parameter Buffer Standard (BUFFER_STANDARD) must be set to “manual”.

Method Steps:

- a. Prompt: Place sensor in buffer 1.
- b. Displayed: Current pH Measurement
Current Temperature Measurement
Prompt: Are values stable?: Yes; No; Abort
Selecting “No” will cause the measurements to be re-read.
- c. If “yes” is chosen:
Displayed: Current pH Measurement
Current Temperature Measurement
Prompt: Enter buffer 1 value.
- d. Prompt: Place sensor in buffer 2.
- e. Displayed: Current pH Measurement
Current Temperature Measurement
Prompt: Are values stable?: Yes; No; Abort
Selecting “No” will cause the measurements to be re-read.
- f. If “yes” is chosen:
Displayed: Current pH Measurement
Current Temperature Measurement
Prompt: Enter buffer 2 value.
- g. If there are calibration errors, they will be displayed, and the corresponding errors will be shown in DeltaV Explorer/Status/Errors Tab.
- h. Displayed: Current pH Measurement
Current Temperature Measurement
New pH Slope Value
New pH Zero Offset Value

The method concludes.

13.6 STANDARDIZATION USING THE INFRARED REMOTE CONTROLLER

1. The pH measured by the transmitter can be changed to match the reading from a second or reference instrument. The process of making the two readings agree is called standardization, or one-point calibration.
2. During standardization, the difference between the two pH values is converted to the equivalent voltage. The voltage, called the reference offset, is added to all subsequent measured cell voltages before they are converted to pH. If a sensor that has been calibrated with buffers is then standardized and placed back in a buffer, the measured pH will differ from the buffer pH by an amount equivalent to the standardization offset.
3. Install the sensor in the process liquid. Once readings are stable, measure the pH of the liquid using a reference instrument. Normally, it is acceptable to test a grab sample. Because the pH of the process liquid may change if the temperature changes, measure the pH immediately after taking the grab sample. For poorly buffered samples, it is best to determine the pH of a continuously flowing sample from a point as close as possible to the process sensor.

4. Press CAL on the remote controller.

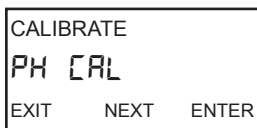

CALIBRATE
PH CAL
EXIT NEXT ENTER

5. Press NEXT until the **PH CAL** submenu appears. Press ENTER.

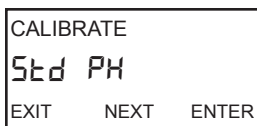

CALIBRATE
Std PH
EXIT NEXT ENTER

6. Press NEXT until the **Std PH** submenu appears. Press ENTER.

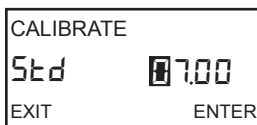

CALIBRATE
Std 7.00
EXIT ENTER

7. Be sure the process pH and temperature are stable. Measure the pH of the process liquid using the reference instrument. Use the arrow keys to change the flashing display to match the reading from the reference meter. Press ENTER to save.

8. Press RESET to return to the main display.

13.7 STANDARDIZATION USING DeltaV

1. The pH measured by the transmitter can be changed to match the reading from a second or reference instrument. The process of making the two readings agree is called standardization, or one-point calibration.
2. During standardization, the difference between the two pH values is converted to the equivalent voltage. The voltage, called the reference offset, is added to all subsequent measured cell voltages before they are converted to pH. If a sensor that has been calibrated with buffers is then standardized and placed back in a buffer, the measured pH will differ from the buffer pH by an amount equivalent to the standardization offset.
3. Install the sensor in the process liquid. Once readings are stable, measure the pH of the liquid using a reference instrument. Normally, it is acceptable to test a grab sample. Because the pH of the process liquid may change if the temperature changes, measure the pH immediately after taking the grab sample. For poorly buffered samples, it is best to determine the pH of a continuously flowing sample from a point as close as possible to the process sensor.

4. Access: DeltaV Explorer/Context Menu

Standardize pH (method_standardize_ph)

Method Steps:

- a. Displayed: Current pH Measurement

Current Temperature Measurement

Prompt: Are values stable?: Yes; No; Abort

Selecting "No" will cause the measurements to be re-read.

- b. If "yes" is chosen:

Displayed: Current pH Measurement

Current Temperature Measurement

New pH Zero Offset

The method concludes.

13.8 pH SLOPE ADJUSTMENT USING THE INFRARED REMOTE CONTROLLER

1. If the slope of the glass electrode is known from other measurements, it can be entered directly into the transmitter. The slope must be entered as the slope at 25°C. To calculate the slope at 25°C from the slope at temperature t°C, use the equation:

$$\text{slope at } 25^{\circ}\text{C} = (\text{slope at } t^{\circ}\text{C}) \frac{298}{t^{\circ}\text{C} + 273}$$

Changing the slope overrides the slope determined from the previous buffer calibration.

2. Press CAL on the remote controller.

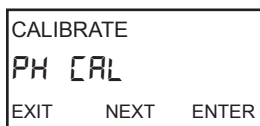

3. Press NEXT until **PH CAL** appears. Press ENTER.



4. Press NEXT until **PH SLOPE** appears. Press ENTER.

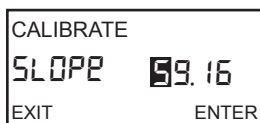

5. The **SLOPE** prompt appears. Use the arrow keys to change the flashing display to the desired slope. Press ENTER to save.

6. Press RESET to return to the main display.

13.9 pH SLOPE ADJUSTMENT USING DeltaV

1. If the slope of the glass electrode is known from other measurements, it can be entered directly into the transmitter. The slope must be entered as the slope at 25°C. To calculate the slope at 25°C from the slope at temperature t°C, use the equation:

$$\text{slope at } 25^{\circ}\text{C} = (\text{slope at } t^{\circ}\text{C}) \frac{298}{t^{\circ}\text{C} + 273}$$

Changing the slope overrides the slope determined from the previous buffer calibration.

2. Access: DeltaV Explorer/Transducer Block/Properties, pH Compensation Tab

Parameter: pH slope (PH_SLOPE)

Enter desired pH slope value.

SECTION 14.0 DIAGNOSTICS

14.1 GENERAL

The 5081-A transmitter can display diagnostic information that is useful in troubleshooting. The diagnostics available depend on the measurement being made. To read diagnostic information, go to the main display and press DIAG on the infrared remote controller. Press NEXT until the mnemonic for the desired information appears. Refer to the appropriate section below for more information.

14.2 DIAGNOSTIC MESSAGES FOR DISSOLVED OXYGEN

TYPE O2	Transmitter is measuring oxygen. Press NEXT to view diagnostics.
SEnSor Cur	Press ENTER to display raw current from sensor (note units).
SEnSivtY	Press ENTER to display sensitivity. Sensitivity is calculated during calibration. It is the measured current divided by concentration.
O CurrEnt	Press ENTER to display the zero current measured during calibration (note units).
bAr PreSS	Press ENTER to display the barometric pressure used by the transmitter during air calibration.
5081-A-FF	This is the model number. Press ENTER to display the software revision (SFtr) level. Press NEXT to show the hardware revision (HArdr) level.
FAULtS	Press ENTER to scroll through existing fault messages.

14.3 DIAGNOSTIC MESSAGES FOR OZONE AND TOTAL CHLORINE

TYPE O3 or tCL	Transmitter is measuring ozone (or total chlorine). Press NEXT to view diagnostics.
SEnSor Cur	Press ENTER to display raw current from sensor (note units).
SEnSivtY	Press ENTER to display sensitivity. Sensitivity is calculated during calibration. It is the measured current divided by concentration.
O CurrEnt	Press ENTER to display the zero current measured during calibration (note units).
5081-A-FF	This is the model number. Press ENTER to display the software revision (SFtr) level. Press NEXT to show the hardware revision (HArdr) level.
FAULtS	Press ENTER to scroll through existing fault messages.

14.4 DIAGNOSTIC MESSAGES FOR FREE CHLORINE

TYPE FCL	Transmitter is measuring free chlorine. Press NEXT to view diagnostics.
SEnSor Cur	Press ENTER to display raw current from sensor (note units).
SEnSitvtY	Press ENTER to display sensitivity. Sensitivity is calculated during calibration. It is the measured current divided by concentration.
O CurrEnt	Press ENTER to display the zero current measured during calibration (note units).
PH	Press ENTER to view pH diagnostics. Press NEXT to skip pH diagnostics.
InPut	Current pH sensor input voltage in millivolts.
SLOPE	Sensor slope in millivolts per unit pH. Slope is calculated during buffer calibration. See Figure 13.1.
OFFSt	Sensor voltage in millivolts in pH 7 buffer.
GIMP	Glass impedance in MΩ.
5081-A-FF	This is the model number. Press ENTER to display the software revision (SFtr) level. Press NEXT to show the hardware revision (HArdr) level.
FAULtS	Press ENTER to scroll through existing fault messages.

SECTION 15.0 TROUBLESHOOTING

- 15.1 WARNING, FAULT, AND ERROR MESSAGES
- 15.2 TROUBLESHOOTING WHEN A WARNING OR FAULT MESSAGE IS SHOWING
- 15.3 TEMPERATURE MEASUREMENT AND CALIBRATION PROBLEMS
- 15.4 OXYGEN MEASUREMENT AND CALIBRATION PROBLEMS
- 15.5 FREE CHLORINE MEASUREMENT AND CALIBRATION PROBLEMS
- 15.6 TOTAL CHLORINE MEASUREMENT AND CALIBRATION PROBLEMS
- 15.7 OZONE MEASUREMENT AND CALIBRATION PROBLEMS
- 15.8 pH MEASUREMENT AND CALIBRATION PROBLEMS
- 15.9 SIMULATING INPUT CURRENTS - DISSOLVED OXYGEN
- 15.10 SIMULATING INPUT CURRENTS - CHLORINE AND OZONE
- 15.11 SIMULATING INPUTS - pH
- 15.12 SIMULATING TEMPERATURE
- 15.13 MEASURING REFERENCE VOLTAGE

15.1 WARNING, FAULT, AND ERROR MESSAGES

The Model 5081-A transmitter continuously monitors the sensor and transmitter for conditions that cause erroneous measurements. When a problem occurs, the transmitter displays either a warning or fault message. A warning alerts the user that a potentially disabling condition exists. There is a high probability that the measurement is in error. A fault alerts the user that a disabling condition exists. If a fault message is showing, all measurements should be regarded as erroneous.

When a **WARNING** condition exists:

1. The main display remains stable; it does not flash.
2. A warning message appears alternately with the temperature and output readings in the second line of the display. See Section 15.4 for an explanation of the warning messages and suggested ways of correcting the problem.

When a **FAULT** exists:

1. The main display flashes.
2. The words **FAULT** and **HOLD** appear in the main display.
3. A fault message appears alternately with the temperature and output readings in the second line of the display. See Section 15.4 for an explanation of the fault messages and suggested ways of correcting the problem.
4. The output current will remain at the present value or go to the programmed fault value. See Section 7.3 for details on how to program the current generated during a fault condition.
5. If the transmitter is in **HOLD** when the fault occurs, the output remains at the programmed hold value. To alert the user that a fault exists, the word **FAULT** appears in the main display, and the display flashes. A fault or diagnostic message also appears.
6. If the transmitter is simulating an output current when the fault occurs, the transmitter continues to generate the simulated current. To alert the user that a fault exists, the word **FAULT** appears in the display, and the display flashes.

When an **ERROR** exists:

1. The main display remains stable; it does not flash.
2. A description of the error appears. Error messages typically appear during calibration.

15.2 TROUBLESHOOTING WHEN A FAULT, WARNING, OR ERROR MESSAGE IS SHOWING

Fault	Explanation	See Section
RTD OPEn	RTD measuring circuit is open.	15.2.1
bAd rtd	RTD resistance is outside the range expected for a Pt100 or 22k NTC.	15.2.1
PHgLASS HI	pH glass impedance exceeds programmed limit.	15.2.2
PHgLASS LO	pH glass impedance is below programmed limit.	15.2.2
AdC FAIL	Analog to digital conversion has failed.	15.2.3
Warning	Explanation	See Section
OuEr rAngE	Process variable exceeds the display limit.	15.2.4
In Curr HI	Sensor input current exceeds 210 uA.	15.2.4
In Curr LO	Sensor input current is a large negative number.	15.2.4
NEED 0 CAL	Sensor needs zeroing. Concentration is a large negative number.	15.2.5
tEMP HI	Temperature reading exceeds 150°C.	15.2.1
tEMP LO	Temperature reading is less than -15°C	15.2.1
SEnSE OPEn	RTD sense line is open or not connected.	15.2.1
PH In HI	mV signal from pH sensor is too big (chlorine only).	15.2.6
NO SOLngnd	Solution ground terminal is not connected.	15.2.7
EECHECSUn	An EEPROM byte changed unexpectedly.	15.2.8
EE OF	During setup or burn, EEPROM command list overflowed.	15.2.9
EE Error	EEPROM byte failed to verify.	15.2.10
bAd Gnd	Bad ground exists.	15.2.11
FAcTcAL	Transmitter needs factory calibration.	15.2.12
Error	Explanation	See Section
SLOPE HI	Glass electrode slope exceeds 62 mV/pH.	15.2.13
SLOPE LO	Glass electrode slope is less than 40 mV/pH.	15.2.13
0 OFFSEt	Zero offset exceeds programmed limit.	15.2.14
CAL ErrOr	Amperometric sensor sensitivity (nA/ppm) is very large or very small	15.2.15
EEProtEct	EEPROM is write protected	15.2.16

15.2.1 RTD OPEn, bAd RTd, tEMP HI, tEMP LO, and SenSE OPEn

These messages usually mean that the RTD (or thermistor in the case of the HX438 and GX448 sensors) is open or shorted or there is an open or short in the connecting wiring.

1. Verify all wiring connections, including wiring in a junction box, if one is being used.
2. Disconnect the RTD IN, RTD SENSE, and RTD RETURN leads or the thermistor leads at the transmitter. Be sure to note the color of the wire and where it was attached. Measure the resistance between the RTD IN and RETURN leads. For a thermistor, measure the resistance between the two leads. The resistance should be close to the value in the table in Section 15.14.2. If the temperature element is open (infinite resistance) or shorted (very low resistance), replace the sensor. In the meantime, use manual temperature compensation.
3. For oxygen measurements using the HX438 and GX448 sensors, or other steam-sterilizable sensor using a 22kNTC, the Temperature High error will appear if the transmitter was not properly configured. See Section 7.4.

15.2.2 pHgLASS HI and pHgLASS LO

These messages mean that the pH sensor glass impedance is outside the programmed limits. To read the glass impedance, go to the main display and press DIAG. Scroll to the **PH** prompt and press ENTER. Press NEXT until **GIMP** (glass impedance) is showing. The default lower limit is 10 MΩ. The default upper limit is 1000 MΩ. Low glass impedance means the glass membrane is broken or cracked. High glass impedance means the membrane is aging and nearing the end of its useful life. High impedance can also mean the pH sensor is not completely submerged in the process liquid.

1. Check sensor wiring, including connections in a junction box.
2. Verify that the sensor is completely submerged in the process liquid.
3. Verify that the software switch identifying the position of the preamplifier is properly set. See Section 7.8.3.
4. Check the sensor response in buffers. If the sensor can be calibrated, it is in satisfactory condition. To disable the GLASS FAIL message reprogram the glass impedance limits to include the measured impedance. If the sensor cannot be calibrated, it has failed and must be replaced.

15.2.3 AdC FAIL

The analog to digital converter has probably failed.

1. Verify that sensor wiring is correct and connections are tight. Be sure to check connections at the junction box if one is being used. See Section 3.1 for wiring information.
2. Disconnect the sensor(s) and simulate temperature and sensor input.

To simulate	See Section
Dissolved oxygen	15.11
Ozone, monochloramine, chlorine	15.12
pH	15.13
Temperature	15.14

3. If the transmitter does not respond to simulate signals, call the factory for assistance.

15.2.4 OuEr rAngE, In Curr HI, and In Curr LO

The first two messages imply that the amperometric sensor current is very high (greater than 210 μA) or the sensor current has a very large negative number. Normally, excessive current or negative current implies that the amperometric sensor is miswired or has failed. Occasionally, these messages may appear when a new sensor is first placed in service.

1. Verify that wiring is correct and connections are tight. Be sure to check connections at the junction box if one is being used. Pay particular attention the anode and cathode connections.
2. Verify that the transmitter is configured for the correct measurement. See Section 7.4. Configuring the measurements sets (among other things) the polarizing voltage. Applying the wrong polarizing voltage to the sensor can cause a large negative current.
3. If the sensor was just placed in service, put the sensor in the zero solution and observe the sensor current. It should be moving fairly quickly toward zero. To view the sensor current go to the main display and press **6** until **Input Current** appears. Note the units: nA is nanoamps, μA is microamps.
4. Replace the sensor membrane and electrolyte solution and clean the cathode if necessary. See the sensor instruction sheet for details.
5. Replace the sensor.

15.2.5 nEED 0 CAL

Need Zero Cal means the measured concentration is a large negative number. The transmitter subtracts the zero current from the measured current before converting the result to a concentration reading. If the zero current is much greater than the measured current, the concentration reading will be negative.

1. Check the zero current and the present sensor current. To view the zero current, go to the main display and press **6** until **Zero Current** appears. The value shown is the zero current the last time the sensor was zeroed. To view the present sensor current, go to the main display and press **6** until **Input Current** appears. Note the units: nA is nanoamps, μA is microamps.
2. Refer to the appropriate section for calibrating the sensor. Place the sensor in the zero solution. Verify that the sensor reading is within or at least very close to the zero current limits. It may take as long as overnight for the sensor to reach a stable zero current.

15.2.6 PH In HI

pH In means the voltage from the pH measuring cell is too large.

1. Verify all wiring connections, including connections in a junction box.
2. Check that the pH sensor is completely submerged in the process liquid.
3. Check the pH sensor for cleanliness. If the sensor looks fouled or dirty, clean it. Refer to the sensor instruction manual for cleaning procedures.
4. Replace the sensor.

15.2.7 No SOLngnd

In the transmitter, the solution ground (Soln GND) terminal is connected to instrument common. Normally, unless the pH sensor has a solution ground, the reference terminal must be jumpered to the solution ground terminal. **HOWEVER, WHEN THE pH SENSOR IS USED WITH A FREE CHLORINE SENSOR THIS CONNECTION IS NEVER MADE.**

15.2.8 EECHECSUn

EE Chksum Error means a software setting changed when it was not supposed to. The EEPROM may be going bad. Call the factory for assistance.

15.2.9 EEOF

EE Buffer Overflow means the software is trying to change too many background variables at once. Remove power from the transmitter for about 30 seconds. If the warning message does not disappear once power is restored, call the factory for assistance.

15.2.10 EE Error

EE Write Error usually means at least one byte in the EEPROM has gone bad. Try entering the data again. If the error message continues to appear, call the factory for assistance.

15.2.11 bAd gnd

This warning message means there is a problem with the analog circuitry. Call the factory for assistance.

15.2.12 FACTCAL

This warning message means the transmitter requires factory calibration. Call the factory for assistance.

15.2.13 SLOPE HI or SLOPE LO

Once the two-point (manual or automatic) pH calibration is complete, the transmitter automatically calculates the sensor slope at 25°C. If the slope is greater than 62 mV/pH the transmitter displays the **SLOPE HI** error. If the slope is less than 45 mV/pH, the transmitter displays the **SLOPE LO** error. The transmitter will not update the calibration.

1. Check the buffers. Inspect the buffer solutions for obvious signs of deterioration, such as turbidity or mold growth. Neutral and slightly acidic buffers are highly susceptible to molds. Alkaline buffers (pH 9 and greater), if they have been exposed to air for long periods, may also be inaccurate. Alkaline buffers absorb carbon dioxide from the atmosphere, which lowers the pH. If a high pH buffer was used in the failed calibration, repeat the calibration using fresh buffer. If fresh buffer is not available, use a lower pH buffer. For example, use pH 4 and pH 7 buffer instead of pH 7 and pH 10 buffer.
2. Allow adequate time for temperature equilibration. If the sensor was in a process liquid substantially hotter or colder than the buffer, place it in a container of water at ambient temperature for at least 20 minutes before starting the calibration.
3. If manual calibration was done, verify that correct pH values were entered.
4. Verify all wiring connections, including connections at a junction box.
5. Check the pH sensor for cleanliness. If the sensor looks fouled or dirty, clean it. Refer to the sensor instruction manual for cleaning procedures.
6. Replace the sensor.

15.2.14 0 OFFSEt

The **-0- OFFSEt** message appears if the standardization offset (in mV) exceeds the programmed limit. The default limit is 60 mV, which is equivalent to about a unit change in pH. Before increasing the limit to make the **-0- OFFSEt** message disappear, check the following:

1. Verify that the reference pH meter is working properly and is properly calibrated.
2. Verify that the process pH sensor is working. Check its response in buffers.
3. If the transmitter is standardized against pH determined in a grab sample, be sure to measure the pH before the temperature of the grab sample changes more than a few degrees.
4. Verify that the process sensor is fully immersed in the liquid. If the sensor is not completely submerged, it may be measuring the pH of the liquid film covering the sensor. The pH of this film may be different from the pH of the bulk liquid.
5. Check the pH sensor for cleanliness. If the sensor looks fouled or dirty, clean it. Refer to the sensor instruction manual for cleaning procedures.
6. A large standardization offset may be caused by a poisoned reference electrode. Poisoning agents can cause the pH to be offset by as much as two pH units. To check the reference voltage, see Section 15.13.

15.2.15 CAL ErrOr

CAL ErrOr appears following a calibration attempt if the new sensitivity is much less or much greater than the value typically expected for the sensor.

1. Verify that the sensor is properly wired to the transmitter.
2. Verify that the sample flow past the sensor is correct and that no air bubbles are trapped against the membrane. For recommended sample flows, refer to the sensor instruction sheet.
3. Verify that the membrane is clean. For oxygen sensors being calibrated in air, also verify that the membrane is dry. For free chlorine measurements using continuous pH correction, verify that the pH sensor is clean.
4. Verify that the laboratory test being used to measure concentrations is accurate.

15.2.16 EEProtECt

Program settings in the 5081-A can be protected against accidental changes by setting a three-digit security code. Settings can further be protected by removing a jumper (JP-1) from the CPU board. If JP-1 has been removed program, settings cannot be changed.

15.3 TEMPERATURE MEASUREMENT AND CALIBRATION PROBLEMS

15.3.1 Temperature measured by standard was more than 1°C different from transmitter.

1. Is the standard thermometer, RTD, or thermistor accurate? General purpose liquid-in-glass thermometers, particularly ones that have been mistreated can have surprisingly large errors.
2. Is the temperature element in the sensor completely submerged in the liquid?
3. Is the standard temperature sensor submerged to the correct level?

15.4 OXYGEN MEASUREMENT AND CALIBRATION PROBLEMS

Problem	See Section
Zero current is substantially greater than the value in Section 9.2	15.4.1
Zero reading is unstable	15.4.2
Sensor current during air calibration is substantially different from the value in Section 9.3	15.4.3
Process and standard instrument readings during in-process calibration are substantially different	15.4.4
Process readings are erratic	15.4.5
Readings drift	15.4.6
Sensor does not respond to changes in oxygen level	15.4.7
Readings are too low	15.4.8

15.4.1 Zero current is substantially greater than the value in Section 9.2.

1. Is the sensor properly wired to the transmitter? See Section 3.0.
2. Is the membrane completely covered with zero solution and are air bubbles not trapped against the membrane? Swirl and tap the sensor to release air bubbles.
3. Is the zero solution fresh and properly made? Zero the sensor in a solution of 5% sodium sulfite in water. Prepare the solution immediately before use. It has a shelf life of only a few days.
4. If the sensor is being zeroed with nitrogen gas, verify that the nitrogen is oxygen-free and the flow is adequate to prevent back-diffusion of air into the chamber.
5. The major contributor to the zero current is dissolved oxygen in the electrolyte solution inside the sensor. A long zeroing period usually means that an air bubble is trapped in the electrolyte. To ensure the 499ADO or 499A TrDO sensor contains no air bubbles, carefully follow the procedure in the sensor manual for filling the sensor. If the electrolyte solution has just been replaced, allow several hours for the zero current to stabilize. On rare occasions, the sensor may require as long as overnight to zero.
6. Check the membrane for damage and replace the membrane if necessary

15.4.2 Zero reading is unstable.

1. Is the sensor properly wired to the transmitter? See Section 3.0. Verify that all wiring connections are tight.
2. Readings are often erratic when a new or rebuilt sensor is first placed in service. Readings usually stabilize after an hour.
3. Is the space between the membrane and cathode filled with electrolyte solution and is the flow path between the electrolyte reservoir and the membrane clear? Often the flow of electrolyte can be started by simply holding the sensor with the membrane end pointing down and sharply shaking the sensor a few times as though shaking down a clinical thermometer. If shaking does not work, perform the checks below. Refer to the sensor instruction manuals for additional information.

For 499ADO and 499A TrDO sensors, verify that the holes at the base of the cathode stem are open (use a straightened paperclip to clear the holes). Also verify that air bubbles are not blocking the holes. Fill the reservoir and establish electrolyte flow to the cathode. Refer to the sensor instruction manual for the detailed procedure.

For Gx438 and Hx438 sensors, the best way to ensure that there is an adequate supply of electrolyte solution is to simply add fresh electrolyte solution to the sensor. Refer to the sensor instruction manual for details.

15.4.3 Sensor current during air calibration is substantially different from the value in Section 9.3.

1. Is the sensor properly wired to the transmitter? See Section 3.0. Verify that all connections are tight.
2. Is the membrane dry? The membrane must be dry during air calibration. A droplet of water on the membrane during air calibration will lower the sensor current and cause an inaccurate calibration.
3. If the sensor current in air is very low and the sensor is new, either the electrolyte flow has stopped or the membrane is torn or loose. For instructions on how to restart electrolyte flow see Section 15.4.2 or refer to the sensor instruction manual. To replace a torn membrane, refer to the sensor instruction manual.
4. Is the temperature low? Sensor current is a strong function of temperature. The sensor current decreases about 3% for every °C drop in temperature.
5. Is the membrane fouled or coated? A dirty membrane inhibits diffusion of oxygen through the membrane, reducing the sensor current. Clean the membrane by rinsing it with a stream of water from a wash bottle or by gently wiping the membrane with a soft tissue. If cleaning the membrane does not improve the sensor response, replace the membrane and electrolyte solution. If necessary, polish the cathode. See the sensor instruction sheet for more information.

15.4.4 Process and standard instrument readings during in-process calibration are substantially different.

This error warning appears if the current process reading and the reading it is being changed to, ie, the reading from the standard instrument, are appreciably different.

1. Is the standard instrument properly zeroed and calibrated?
2. Are the standard and process sensor measuring the same sample? Place the sensors as close together as possible.
3. Is the process sensor working properly? Check the response of the process sensor in air and in sodium sulfite solution.

15.4.5 Process readings are erratic.

1. Readings are often erratic when a new sensor or a rebuilt sensor is first placed in service. The current usually stabilizes after a few hours.
2. Is the sample flow within the recommended range? High sample flow may cause erratic readings. Refer to the sensor instruction manual for recommended flow rates.
3. Gas bubbles impinging on the membrane may cause erratic readings. Orienting the sensor at an angle away from vertical may reduce the noise.
4. The holes between the membrane and electrolyte reservoir might be plugged (applies to Models 499A DO and 499A TrDO sensors only). Refer to Section 15.4.2.
5. Verify that wiring is correct. Pay particular attention to shield and ground connections.
6. Is the membrane in good condition and is the sensor filled with electrolyte solution? Replace the fill solution and electrolyte. Refer to the sensor instruction manual for details.

15.4.6 Readings drift.

1. Is the sample temperature changing? Membrane permeability is a function of temperature. For the 499ADO and 499ATrDO sensors, the time constant for response to a temperature change is about five (5) minutes. Therefore, the reading may drift for a while after a sudden temperature change. The time constant for the Gx438 and Hx448 sensors is much shorter; these sensors respond fairly rapidly to temperature changes.
2. Is the membrane clean? For the sensor to work properly oxygen must diffuse freely through the membrane. A coating on the membrane will interfere with the passage of oxygen, resulting in slow response.
3. Is the sensor in direct sunlight? If the sensor is in direct sunlight during air calibration, readings will drift as the sensor warms up. Because the temperature reading lags the true temperature of the membrane, calibrating the sensor in direct sunlight may introduce an error.
4. Is the sample flow within the recommended range? Gradual loss of sample flow will cause downward drift.
5. Is the sensor new or has it been recently serviced? New or rebuilt sensors may require several hours to stabilize.

15.4.7 Sensor does not respond to changes in oxygen level.

1. If readings are being compared with a portable laboratory instrument, verify that the laboratory instrument is working.
2. Is the membrane clean? Clean the membrane and replace it if necessary. Check that the holes at the base of the cathode stem are open. Use a straightened paper clip to clear blockages. Replace the electrolyte solution.
3. Replace the sensor.

15.4.8 Oxygen readings are too low.

1. Low readings can be caused by zeroing the sensor before the residual current has reached a stable minimum value. Residual current is the current the sensor generates even when no oxygen is in the sample. Because the residual current is subtracted from subsequent measured currents, zeroing before the current is a minimum can lead to low results.

Example: the true residual (zero) current for a 499ADO sensor is 0.05 μA , and the sensitivity based on calibration in water-saturated air is 2.35 $\mu\text{A/ppm}$. Assume the measured current is 2.00 μA . The true concentration is $(2.00 - 0.05)/2.35$ or 0.83 ppm. If the sensor was zeroed prematurely when the current was 0.2 μA , the measured concentration will be $(2.00 - 0.2)/2.35$ or 0.77 ppm. The error is 7.2%. Suppose the measured current is 5.00 μA . The true concentration is 2.11 ppm, and the measured concentration is 2.05 ppm. The error is now 3.3%. The absolute difference between the readings remains the same, 0.06 ppm.

2. Sensor response depends on flow. If the flow is too low, readings will be low and flow sensitive. Verify that the flow past the sensor equals or exceeds the minimum value. See the sensor instruction manual for recommended flows. If the sensor is in an aeration basin, move the sensor to an area where the flow or agitation is greater.

15.5 FREE CHLORINE MEASUREMENT AND CALIBRATION PROBLEMS

Problem	See Section
Zero current is substantially outside the range -10 to 10 nA	15.5.1
Zero reading is unstable	15.5.2
Sensor current during calibration is substantially less than about 250 nA/ppm at 25°C and pH 7	15.5.3
Process readings are erratic	15.5.4
Readings drift	15.5.5
Sensor does not respond to changes in chlorine level	15.5.6
Chlorine reading spikes following rapid change in pH (automatic pH correction only)	15.5.7
Readings are too low	15.5.8

15.5.1 Zero current is substantially outside the range -10 to 10 nA.

1. Is the sensor properly wired to the transmitter? See Section 3.0.
2. Is the zero solution chlorine-free? Take a sample of the solution and test it for free chlorine level. The concentration should be less than 0.02 ppm.
3. Has adequate time been allowed for the sensor to reach a minimum stable residual current? It may take several hours, sometimes as long as overnight, for a new sensor to stabilize.
4. Check the membrane for damage and replace it if necessary.

15.5.2 Zero reading is unstable.

1. Is the sensor properly wired to the transmitter? See Section 3.0. Verify that all wiring connections are tight.
2. Readings are often erratic when a new or rebuilt sensor is first placed in service. Readings usually stabilize after about an hour.
3. Is the conductivity of the zero solution greater than 50 $\mu\text{S}/\text{cm}$? DO NOT USE DEIONIZED OR DISTILLED WATER TO ZERO THE SENSOR. The zero solution should contain at least 0.5 grams of sodium chloride per liter.
4. Is the space between the membrane and cathode filled with electrolyte solution and is the flow path between the electrolyte reservoir and membrane clear? Often the flow of electrolyte can be started by simply holding the sensor with the membrane end pointing down and sharply shaking the sensor a few times as though shaking down a clinical thermometer.

If shaking does not work, try clearing the holes around the cathode stem. Hold the sensor with the membrane end pointing up. Unscrew the membrane retainer and remove the membrane assembly. Be sure the wood ring remains with the membrane assembly. Use the end of a straightened paper clip to clear the holes at the base of the cathode stem. Replace the membrane.

Verify that the sensor is filled with electrolyte solution. Refer to the sensor instruction manual for details.

15.5.3 Sensor current during calibration is substantially less than 250 nA/ppm at 25°C and pH 7.

1. Is the temperature low or is the pH high? Sensor current is a strong function of pH and temperature. The sensor current decreases about 3% for every $^{\circ}\text{C}$ drop in temperature. Sensor current also decreases as pH increases. Above pH 7, a 0.1 unit increase in pH lowers the current about 5%.
2. Sensor current depends on the rate of sample flow past the sensor tip. If the flow is too low, chlorine readings will be low. Refer to the sensor instruction sheet for recommended sample flows.
3. Low current can be caused by lack of electrolyte flow to the cathode and membrane. See step 4 in Section 15.5.2.
4. Is the membrane fouled or coated? A dirty membrane inhibits diffusion of free chlorine through the membrane, reducing the sensor current and increasing the response time. Clean the membrane by rinsing it with a stream of water from a wash bottle. DO NOT use a membrane or tissue to wipe the membrane.
5. If cleaning the membrane does not improve the sensor response, replace the membrane and electrolyte solution. If necessary, polish the cathode. See the sensor instruction sheet for details.

15.5.4 Process readings are erratic.

1. Readings are often erratic when a new sensor or a rebuilt sensor is first placed in service. The current usually stabilizes after a few hours.
2. Is the sample flow within the recommended range? High sample flow may cause erratic readings. Refer to the sensor instruction sheet for recommended flow rates.
3. Are the holes between the membrane and the electrolyte reservoir open. Refer to Section 15.5.2.
4. Verify that wiring is correct. Pay particular attention to shield and ground connections.
5. If automatic pH correction is being used, check the pH reading. If the pH reading is noisy, the chlorine reading will also be noisy. If the pH sensor is the cause of the noise, use manual pH correction until the problem with the pH sensor can be corrected.
6. Is the membrane in good condition and is the sensor filled with electrolyte solution? Replace the fill solution and electrolyte. Refer to the sensor instruction manual for details.

15.5.5 Readings drift.

1. Is the sample temperature changing? Membrane permeability is a function of temperature. The time constant for the 499ACL-01 sensor is about five minutes. Therefore, the reading may drift for a while after a sudden temperature change.
2. Is the membrane clean? For the sensor to work properly, chlorine must diffuse freely through the membrane. A coating on the membrane will interfere with the passage of chlorine, resulting in slow response. Clean the membrane by rinsing it with a stream of water from a wash bottle. **DO NOT** use a membrane or tissue to wipe the membrane.
3. Is the sample flow within the recommended range? Gradual loss of sample flow will cause a downward drift.
4. Is the sensor new or has it been recently serviced? New or rebuilt sensors may require several hours to stabilize.
5. Is the pH of the process changing? If manual pH correction is being used, a gradual change in pH will cause a gradual change in the chlorine reading. As pH increases, chlorine readings will decrease, even though the free chlorine level (as determined by a grab sample test) remained constant. If the pH change is no more than about 0.2, the change in the chlorine reading will be no more than about 10% of reading. If the pH changes are more than 0.2, use automatic pH correction.

15.5.6 Sensor does not respond to changes in chlorine level.

1. Is the grab sample test accurate? Is the grab sample representative of the sample flowing to the sensor?
2. Is the pH compensation correct? If the transmitter is using manual pH correction, verify that the pH value in the transmitter equals the actual pH to within ± 0.1 pH. If the transmitter is using automatic pH correction, check the calibration of the pH sensor.
3. Is the membrane clean? Clean the membrane and replace it if necessary. Check that the holes at the base of the cathode stem are open. Use a straightened paper clip to clear blockages. Replace the electrolyte solution.
4. Replace the sensor.

15.5.7 Chlorine readings spike following sudden changes in pH.

Changes in pH alter the relative amounts of hypochlorous acid (HOCl) and hypochlorite ion (OCl⁻) in the sample. Because the sensor responds only to HOCl, an increase in pH causes the sensor current (and the apparent chlorine level) to drop even though the actual free chlorine concentration remained constant. To correct for the pH effect, the transmitter automatically applies a correction. Generally, the pH sensor responds faster than the chlorine sensor. After a sudden pH change, the transmitter will temporarily over-compensate and gradually return to the correct value. The time constant for return to normal is about five (5) minutes.

15.5.8 Chlorine readings are too low.

1. Was the sample tested as soon as it was taken? Chlorine solutions are unstable. Test the sample immediately after collecting it. Avoid exposing the sample to sunlight.
2. Low readings can be caused by zeroing the sensor before the residual current has reached a stable minimum value. Residual current is the current the sensor generates even when no chlorine is in the sample. Because the residual current is subtracted from subsequent measured currents, zeroing before the current is a minimum can lead to low results. See Section 15.4.8 for more information.
3. Sensor response depends on flow. If the flow is too low, readings will be low and flow sensitive. Verify that the flow past the sensor equals or exceeds the minimum value. See the sensor instruction manual for recommended flows.

15.6 TOTAL CHLORINE MEASUREMENT AND CALIBRATION PROBLEMS

Refer to the instruction manual for the SCS921 for a complete troubleshooting guide.

15.7 OZONE MEASUREMENT AND CALIBRATION PROBLEMS

Problem	See Section
Zero current is substantially outside the range -10 to 10 nA	15.7.1
Zero reading is unstable	15.7.2
Sensor current during calibration is substantially less than about 350 nA/ppm at 25°C	15.7.3
Process readings are erratic	15.7.4
Readings drift	15.7.5
Sensor does not respond to changes in ozone level	15.7.6
Ozone readings are too low	15.7.7

15.7.1 Zero current is substantially outside the range -10 to 10 nA.

1. Is the sensor properly wired to the transmitter? See Section 3.0.
2. Is the zero solution ozone free? Test the zero solution for ozone level. The concentration should be less than 0.02 ppm.
3. Has adequate time been allowed for the sensor to reach a minimum stable residual current? It may take several hours, sometimes as long as overnight, for a new sensor to stabilize.
4. Check the membrane for damage and replace it if necessary.

15.7.2 Zero reading is unstable.

1. Is the sensor properly wired to the transmitter? See Section 3.0. Verify that all wiring connections are tight.
2. Readings are often erratic when a new or rebuilt sensor is first placed in service. Readings usually stabilize after about an hour.
3. Is the space between the membrane and cathode filled with electrolyte solution and is the flow path between the electrolyte reservoir and membrane clear? Often the flow of electrolyte can be started by simply holding the sensor with the membrane end pointing down and sharply shaking the sensor a few times as though shaking down a clinical thermometer.

If shaking does not work, try clearing the holes around the cathode stem. Hold the sensor with the membrane end pointing up. Unscrew the membrane retainer and remove the membrane assembly. Be sure the wood ring remains with the membrane assembly. Use the end of a straightened paper clip to clear the holes at the base of the cathode stem. Replace the membrane.

Verify that the sensor is filled with electrolyte solution. Refer to the sensor instruction manual for details.

15.7.3 Sensor current during calibration is substantially less than 350 nA/ppm at 25°C.

1. Sensor current is a strong function of temperature. The sensor current decreases about 3% for every °C drop in temperature.
2. Sensor current depends on the rate of sample flow past the sensor tip. If the flow is too low, ozone readings will be low. Refer to the sensor instruction sheet for recommended sample flows.
3. Low current can be caused by lack of electrolyte flow to the cathode and membrane. See step 3 in Section 15.7.2.
4. Is the membrane fouled or coated? A dirty membrane inhibits diffusion of ozone through the membrane, reducing the sensor current and increasing the response time. Clean the membrane by rinsing it with a stream of water from a wash bottle or gently wipe the membrane with a soft tissue.

If cleaning the membrane does not improve the sensor response, replace the membrane and electrolyte solution. If necessary, polish the cathode. See the sensor instruction sheet for details.

15.7.4 Process readings are erratic.

1. Readings are often erratic when a new sensor or a rebuilt sensor is first placed in service. The current usually stabilizes after a few hours.
2. Is the sample flow within the recommended range? High sample flow may cause erratic readings. Refer to the sensor instruction sheet for recommended flow rates.
3. Are the holes between the membrane and the electrolyte reservoir open. Refer to Section 15.7.2.
4. Verify that wiring is correct. Pay particular attention to shield and ground connections.
5. Is the membrane in good condition and is the sensor filled with electrolyte solution? Replace the fill solution and electrolyte. Refer to the sensor instruction manual for details.

15.7.5 Readings drift.

1. Is the sample temperature changing? Membrane permeability is a function of temperature. The time constant for the 499AOZ sensor is about five minutes. Therefore, the reading may drift for a while after a sudden temperature change.
2. Is the membrane clean? For the sensor to work properly, ozone must diffuse freely through the membrane. A coating on the membrane will interfere with the passage of ozone, resulting in slow response. Clean the membrane by rinsing it with a stream of water from a wash bottle, or gently wipe the membrane with a soft tissue.
3. Is the sample flow within the recommended range? Gradual loss of sample flow will cause a downward drift.
4. Is the sensor new or has it been recently serviced. New or rebuilt sensors may require several hours to stabilize.

15.7.6 Sensor does not respond to changes in ozone level.

1. Is the grab sample test accurate? Is the grab sample representative of the sample flowing to the sensor?
2. Is the membrane clean? Clean the membrane and replace it if necessary. Check that the holes at the base of the cathode stem are open. Use a straightened paper clip to clear blockages. Replace the electrolyte solution.
3. Replace the sensor.

15.7.7 Ozone readings are too low.

1. Was the sample tested as soon as it was taken? Ozone solutions are highly unstable. Test the sample immediately after collecting it.
2. Low readings can be caused by zeroing the sensor before the residual current has reached a stable minimum value. Residual current is the current the sensor generates even when no ozone is in the sample. Because the residual current is subtracted from subsequent measured currents, zeroing before the current is a minimum can lead to low results. See Section 15.4.8 for more information.
3. Sensor response depends on flow. If the flow is too low, readings will be low and flow sensitive. Verify that the flow past the sensor equals or exceeds the minimum value. See the sensor instruction manual for recommended flows.

15.8 pH MEASUREMENT AND CALIBRATION PROBLEMS

Problem	See Section
SLOPE HI or SLOPE LO message is showing	15.8.1
-0- OFFSEt message is showing	15.8.2
Transmitter will not accept manual slope	15.8.3
Sensor does not respond to known pH changes	15.8.4
Process pH is slightly different from the expected value	15.8.5
Process pH reading changes when flow changes	15.8.6
Process pH is grossly wrong and/or noisy	15.8.7
Process readings are noisy	15.8.8

15.8.1 SLOPE HI or SLOPE LO message is showing.

Refer to Section 15.2.9 for assistance.

15.8.2 -0- OFFSEt message is showing.

Refer to Section 15.2.10 for assistance.

15.8.3 Transmitter will not accept manual slope.

If the sensor slope is known from other sources, it can be entered directly into the transmitter. The transmitter will not accept a slope (at 25°) outside the range 45 to 60 mV/pH. If the user attempts to enter a slope less than 45 mV/pH, the transmitter will automatically change the entry to 45. If the user attempts to enter a slope greater than 60 mV/pH, the transmitter will change the entry to 60 mV/pH. See Section 14.8.1 for troubleshooting sensor slope problems.

15.8.4 Sensor does not respond to known pH changes.

1. Did the expected pH change really occur? If the process pH reading was not what was expected, check the performance of the sensor in buffers. Also, use a second pH meter to verify the change.
2. Is the sensor properly wired to the transmitter?
3. Is the glass bulb cracked or broken? Check the glass electrode impedance. See Section 14.1
4. Is the transmitter working properly. Check the transmitter by simulating the pH input.

15.8.5 Process pH is slightly different from the expected value.

Differences between pH readings made with an on-line instrument and a laboratory or portable instrument are normal. The on-line instrument is subject to process variables, for example ground potentials, stray voltages, and orientation effects that may not affect the laboratory or portable instrument. To make the process reading agree with a reference instrument, see Section 13.4.

15.8.6 Process pH reading changes when flow changes.

The 399 pH sensor recommended for use with the 5081A transmitter has some degree of flow sensitivity, i.e., changing the sample flow causes the pH reading to change. Flow sensitivity varies from sensor to sensor. Flow sensitivity can be a source of error if the pH and chlorine sensor flow cells are connected in series. The chlorine sensor requires a fairly rapidly flowing sample, and high flows may affect the pH reading. Typically, the difference in pH reading from a 399 pH sensor in a rapidly (16 gph) and slowly (<2 gph) flowing sample is less than about 0.05. If the change is greater than 0.05, the pH and chlorine sensors should be installed in parallel streams.

15.8.7 Process pH is grossly wrong and/or noisy.

Grossly wrong or noisy readings suggest a ground loop (measurement system connected to earth ground at more than one point), a floating system (no earth ground), or noise being brought into the transmitter by the sensor cable. The problem arises from the process or installation. It is not a fault of the transmitter. The problem should disappear once the sensor is taken out of the system. Check the following:

1. Is a ground loop present?
 - a. Verify that the system works properly in buffers. Be sure there is no direct electrical connection between the buffer containers and the process liquid or piping.
 - b. Strip back the ends of a heavy gauge wire. Connect one end of the wire to the process piping or place it in the process liquid. Place the other end of the wire in the container of buffer with the sensor. The wire makes an electrical connection between the process and sensor.
 - c. If offsets and noise appear after making the connection, a ground loop exists.
2. Is the process grounded?
 - a. The measurement system needs one path to ground: through the process liquid and piping. Plastic piping, fiber-glass tanks, and ungrounded or poorly grounded vessels do not provide a path. A floating system can pick up stray voltages from other electrical equipment.
 - b. Ground the piping or tank to a local earth ground.
 - c. If noise still persists, simple grounding is not the problem. Noise is probably being carried into the instrument through the sensor wiring.
3. Simplify the sensor wiring.
 - a. First, verify that pH sensor wiring is correct.
 - b. Disconnect all sensor wires at the transmitter except pH/mV IN, REFERENCE IN, RTD IN and RTD RETURN. See the wiring diagrams in Section 3.0. If the sensor is wired to the transmitter through a remote junction box containing a preamplifier, disconnect the wires at the sensor side of the junction box.
 - c. Tape back the ends of the disconnected wires to keep them from making accidental connections with other wires or terminals.
 - d. Connect a jumper wire between the RTD RETURN and RTD SENSE terminals (see wiring diagrams in Section 3.0).
 - e. If noise and/or offsets disappear, the interference was coming into the transmitter through one of the sensor wires. The system can be operated permanently with the simplified wiring.
4. Check for extra ground connections or induced noise.
 - a. If the sensor cable is run inside conduit, there may be a short between the cable and the conduit. Re-run the cable outside the conduit. If symptoms disappear, there is a short between the cable and the conduit. Likely a shield is exposed and touching the conduit. Repair the cable and reinstall it in the conduit.
 - b. To avoid induced noise in the sensor cable, run it as far away as possible from power cables, relays, and electric motors. Keep sensor wiring out of crowded panels and cable trays.
 - c. If ground loops persist, consult the factory. A visit from a service technician may be required to solve the problem.

15.8.8 Process readings are noisy.

1. What is the conductivity of the sample? Measuring pH in samples having conductivity less than about 50 μ S/cm can be very difficult. Special sensors (for example, the Model 320HP) are often needed and special attention must be paid to grounding and sample flow rate.

NOTE:

Measuring free chlorine in samples having low conductivity can also be a problem. Generally, for a successful chlorine measurement, the conductivity should be greater than 50 μ S/cm.

2. Is the sensor dirty or fouled? Suspended solids in the sample can coat the reference junction and interfere with the electrical connection between the sensor and the process liquid. The result is often a noisy reading.
3. Is the sensor properly wired to the transmitter? See Section 3.0.
4. Is a ground loop present? Refer to Section 15.8.7.

15.9 SIMULATING INPUT CURRENTS - DISSOLVED OXYGEN

To check the performance of the transmitter, use a decade box to simulate the current from the oxygen sensor.

- A. Disconnect the anode and cathode leads from terminals 13 & 14 and connect a decade box as shown in Figure 15-1. It is not necessary to disconnect the RTD leads.
- B. Set the decade box to the resistance shown in the table.

Sensor	Polarizing Voltage	Resistance	Expected Current
499ADO	-675 mV	34 kΩ	20 μA
499ATrDO	-800 mV	20 kΩ	40 μA
Hx438 and Gx448	-675 mV	8.4 MΩ	80 nA

- C. Note the sensor current. To view the sensor current, go to the main display and press DIAG. Then press NEXT. **SEnSor Cur** will appear in the display. Press ENTER. The display will show the sensor current. Note the units: **μA** is microamps; **nA** is nanoamps.
- D. Change the decade box resistance and verify that the correct current is shown. Calculate the current from the equation:

$$\text{current } (\mu\text{A}) = \frac{\text{voltage (mV)}}{\text{resistance (k}\Omega\text{)}}$$

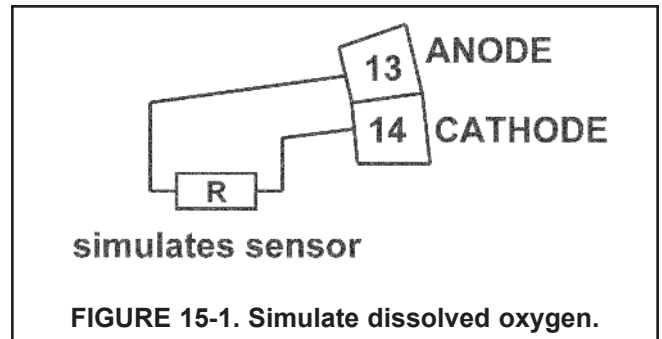

15.10 SIMULATING INPUT CURRENTS - CHLORINE AND OZONE

To check the performance of the transmitter, use a decade box and a battery to simulate the current from the sensor. The battery, which opposes the polarizing voltage, is necessary to ensure that the sensor current has the correct sign.

- A. Disconnect the anode and cathode leads from terminals 13 & 14 and connect a decade box as shown in Figure 15-1. It is not necessary to disconnect the RTD leads.
- B. Set the decade box to the resistance shown in the table.

Sensor	Polarizing Voltage	Resistance	Expected Current
499ACL-01 (free chlorine)	200 mV	28 MΩ	500 nA
499ACL-02 (total chlorine)	250 mV	675 kΩ	2000 nA
499AOZ	200 mV	2.7 MΩ	500 nA

- C. Note the sensor current. It should be close to the value in the table. The actual value depends on the voltage of the battery. To view the sensor current, go to the main display and press DIAG. Then, press NEXT. **SEnSor Cur** will appear in the display. Press ENTER. The display will show the sensor current. Note the units: **μA** is microamps; **nA** is nanoamps.
- D. Change the decade box resistance and verify that the correct current is shown. Calculate the current from the equation:

$$\text{current } (\mu\text{A}) = \frac{V_{\text{battery}} - V_{\text{polarizing (mV)}}}{\text{resistance (k}\Omega\text{)}}$$

The voltage of a fresh 1.5 volt battery is about 1.6 volt (1600 mV).

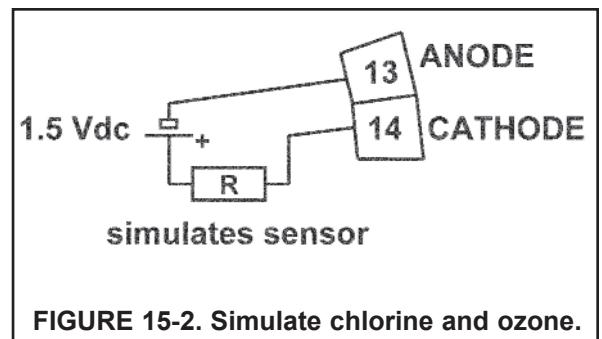

15.11 SIMULATING INPUTS - pH

15.11.1 General

This section describes how to simulate a pH input into the transmitter. To simulate a pH measurement, connect a standard millivolt source to the transmitter. If the transmitter is working properly, it will accurately measure the input voltage and convert it to pH. Although the general procedure is the same, the wiring details depend on whether the preamplifier is in the sensor, a junction box, or the transmitter.

15.11.2 Simulating pH input when the preamplifier is in the analyzer.

1. Turn off automatic temperature correction and set the manual temperature to 25°C (Section 7.4).
2. Disconnect the pH sensor. Also, disconnect the chlorine sensor anode lead. Connect a jumper wire between the pH IN and REF IN terminals.
3. Confirm that the transmitter is reading the correct mV value. With the main display showing, press DIAG. Press NEXT until the display shows **PH**. Press ENTER. The display will show **InPUt** followed by a number. The number is the raw input signal in millivolts. The measured voltage should be 0 mV.
4. Confirm that the transmitter is reading the correct pH value. Go to the main display. Press **3** or **5**. The second line of the display will show the pH. The pH should be approximately 7.00. Because calibration data stored in the analyzer may be offsetting the input voltage, the displayed pH may not be exactly 7.00.
5. If a standard millivolt source is available, disconnect the jumper wire between the pH IN and REF IN terminals and connect the voltage source as shown in Figure 15.3.
6. Calibrate the transmitter using the procedure in Section 13.3. Use 0.0 mV for Buffer 1 (pH 7.00) and -177.4 mV for Buffer 2 (pH 10.00). If the analyzer is working properly, it should accept the calibration. The slope should be 59.16 mV/pH, and the offset should be zero.
7. To check linearity, set the voltage source to the values shown in the table and verify that the pH and millivolt readings match the values in the table.

Voltage (mV)	pH (at 25°)
295.8	2.00
177.5	4.00
59.2	6.00
59.2	8.00
177.5	10.00
295.8	12.00

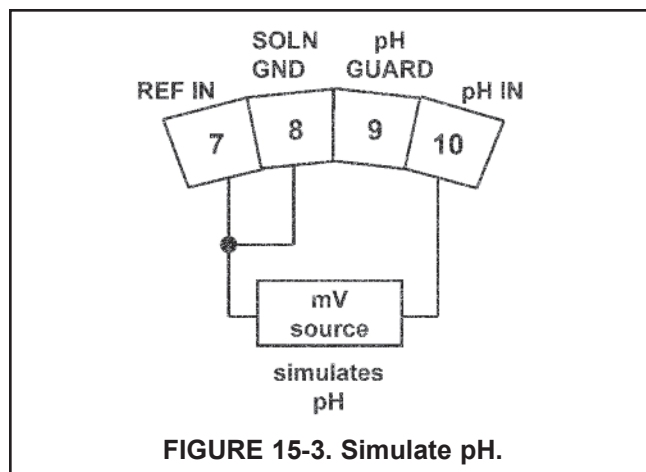

15.11.3 Simulating pH input when the preamplifier is in a junction box.

The procedure is the same as described in section 15.11.2. Keep the connection between the analyzer and the junction box in place. Disconnect the sensor at the sensor side of the junction box and connect the voltage source to the sensor side of the junction box.

15.11.4 Simulating pH input when the preamplifier is in the sensor.

The preamplifier in the sensor converts the high impedance signal into a low impedance signal without amplifying it. To simulate pH values, follow the procedure in Section 15.11.2.

15.12 SIMULATING TEMPERATURE

15.12.1 General

The transmitter accepts either a Pt100 RTD (used in pH, 499ADO, 499ATrDO, 499ACL-01, 499ACL-02, and 499AOZ sensors) or a 22k NTC thermistor (used in HX438 and Gx448 DO sensors and most steam-sterilizable sensors from other manufacturers). The Pt100 RTD has a three-wire configuration. See Figure 15-4. The thermistor has a two-wire configuration.

15.12.2 Simulating temperature

To simulate the temperature input, wire a decade box to the analyzer or junction box as shown in Figure 15-5.

To check the accuracy of the temperature measurement, set the resistor simulating the RTD to the values indicated in the table and note the temperature readings. The measured temperature might not agree with the value in the table. During sensor calibration an offset might have been applied to make the measured temperature agree with a standard thermometer. The offset is also applied to the simulated resistance. The controller is measuring temperature correctly if the difference between measured temperatures equals the difference between the values in the table to within $\pm 0.1^\circ\text{C}$.

For example, start with a simulated resistance of $103.9\ \Omega$, which corresponds to 10.0°C . Assume the offset from the sensor calibration was $-0.3\ \Omega$. Because of the offset, the analyzer calculates temperature using $103.6\ \Omega$. The result is 9.2°C . Now change the resistance to $107.8\ \Omega$, which corresponds to 20.0°C . The analyzer uses $107.5\ \Omega$ to calculate the temperature, so the display reads 19.2°C . Because the difference between the displayed temperatures (10.0°C) is the same as the difference between the simulated temperatures, the analyzer is working correctly.

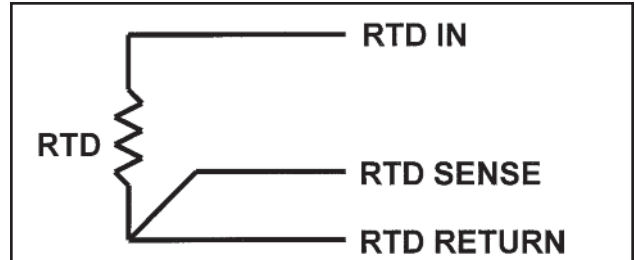

FIGURE 15-4. Three-Wire RTD Configuration.

Although only two wires are required to connect the RTD to the analyzer, using a third wire allows the analyzer to correct for the resistance of the lead wires and for changes in the lead wire resistance with temperature.

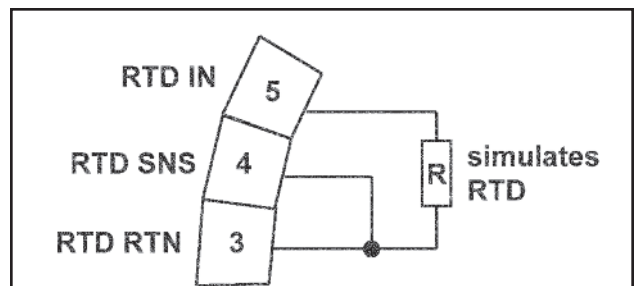

FIGURE 15-5. Simulating RTD Inputs.

The figure shows wiring connections for sensors containing a Pt 100 RTD. For sensors using a 22k NTC thermistor (Hx438 and Gx448 sensors), wire the decade box to terminals 1 and 3 on TB6.

Temp. ($^\circ\text{C}$)	Pt 100 (Ω)	22k NTC ($\text{k}\Omega$)
0	100.0	64.88
10	103.9	41.33
20	107.8	26.99
25	109.7	22.00
30	111.7	18.03
40	115.5	12.31
50	119.4	8.565
60	123.2	6.072
70	127.1	4.378
80	130.9	3.208
85	132.8	2.761
90	134.7	2.385
100	138.5	1.798

15.13 MEASURING REFERENCE VOLTAGE

Some processes contain substances that poison or shift the potential of the reference electrode. Sulfide is a good example. Prolonged exposure to sulfide converts the reference electrode from a silver/silver chloride electrode to a silver/silver sulfide electrode. The change in reference voltage is several hundred millivolts. A good way to check for poisoning is to compare the voltage of the reference electrode with a silver/silver chloride electrode known to be good. The reference electrode from a new sensor is best. See Figure 15-6. If the reference electrode is good, the voltage difference should be no more than about 20 mV. A poisoned reference electrode usually requires replacement

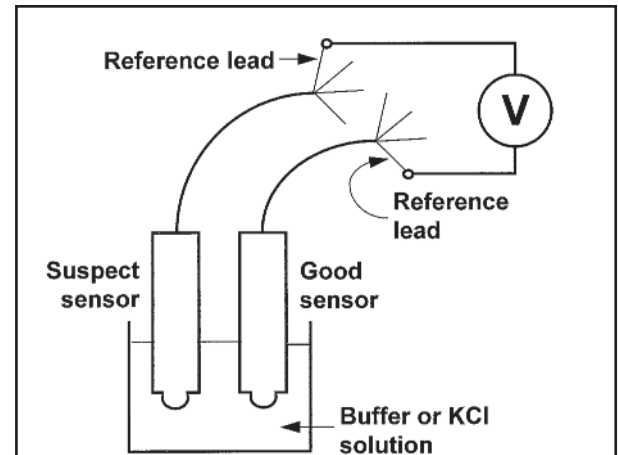

FIGURE 15-6. Checking for a Poisoned Reference Electrode.

Refer to the sensor wiring diagram to identify the reference leads. A laboratory silver/silver chloride electrode can be used in place of the second sensor.

SECTION 16.0 MAINTENANCE

16.1 OVERVIEW

This section gives general procedures for routine maintenance of the 5081-A transmitter. The transmitter needs almost no routine maintenance.

16.2 TRANSMITTER MAINTENANCE

Periodically clean the transmitter window with household ammonia or glass cleaner. The detector for the infrared remote controller is located behind the window at the top of the transmitter face. The window in front of the detector must be kept clean.

Most components of the transmitter are replaceable. Refer to Figure 16-1 and Table 16-1 for parts and part numbers.

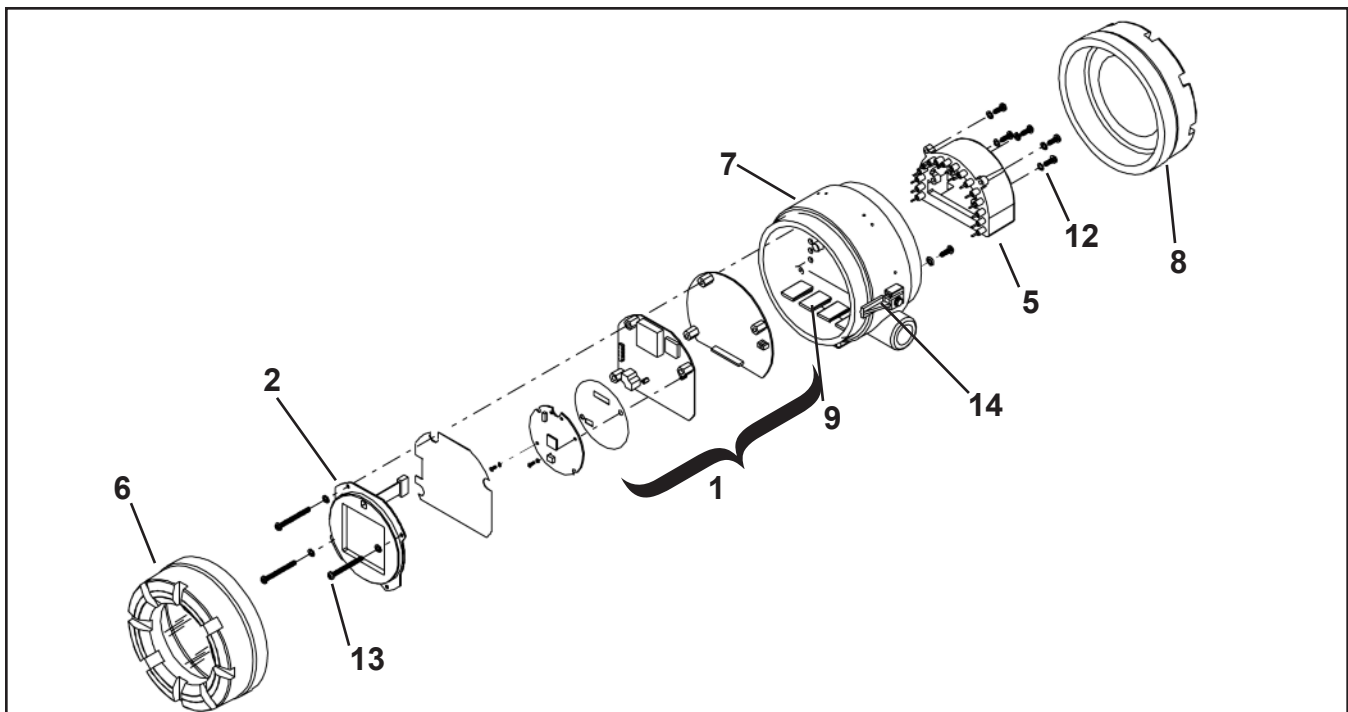

FIGURE 16-1. Exploded View of Model 5081-A Transmitter

Three screws (part 13 in the drawing) hold the circuit boards in place. Removing the screws allows the display board (part 2) and the CPU board (part 3) to be easily removed. A ribbon cable connects the boards. The cable plugs into the CPU board and is permanently attached to the display board. A 16 pin and socket connector holds the CPU and analog (part 4) boards together. Five screws hold the terminal block (part 5) to the center housing (part 7), and the 16 pins on the terminal block mate with 16 sockets on the back side of the analog board. Use caution when separating the terminal block from the analog board. The pin and socket connection is tight.

TABLE 16-1. Replacement Parts for Model 5081-A Transmitter

Location in Figure 16-1	PN	Description	Shipping Weight
1	23992-01	PCB stack consisting of the CPU, communication, and analog boards; display board is not included; CPU, communication, and analog boards are factory-calibrated as a unit and cannot be ordered separately	1 lb/0.5 kg
2	23652-01	LCD display PCB	1 lb/0.5 kg
5	33337-02	Terminal block	1 lb/0.5 kg
6	23593-01	Enclosure cover, front with glass window	3 lb/1.5 kg
7	33360-00	Enclosure, center housing	4 lb/1.5 kg
8	33362-00	Enclosure cover, rear	3 lb/1.0 kg
9	6560135	Desiccant in bag, one each	1 lb/0.5 kg
	9550187	O-ring (2-252), one, front and rear covers each require an O-ring	1 lb/0.5 kg
12	note	Screw, 8-32 x 0.5 inch, for attaching terminal block to center housing	*
13	note	Screw, 8-32 x 1.75 inch, for attaching circuit board stack to center housing	*
14	33342-00	Cover lock	1 lb/0.5 kg
14	33343-00	Locking bracket nut	1 lb/0.5 kg
	note	Screw, 10-24 x 0.38 inch, for attaching cover lock and locking bracket nut to center housing	*

NOTE: For information only. Screws cannot be purchased from Rosemount Analytical.

* Weights are rounded up to the nearest whole pound or 0.5 kg.

SECTION 17.0 RETURN OF MATERIAL

17.1 GENERAL.

To expedite the repair and return of instruments, proper communication between the customer and the factory is important. Call 1-949-757-8500 for a Return Materials Authorization (RMA) number.

17.2 WARRANTY REPAIR.

The following is the procedure for returning instruments still under warranty:

1. Call Rosemount Analytical for authorization.
2. To verify warranty, supply the factory sales order number or the original purchase order number. In the case of individual parts or sub-assemblies, the serial number on the unit must be supplied.
3. Carefully package the materials and enclose your "Letter of Transmittal" (see Warranty). If possible, pack the materials in the same manner as they were received.
4. Send the package prepaid to:

Emerson Process Management
Rosemount Analytical
2400 Barranca Parkway
Irvine, CA 92606

Attn: Factory Repair

RMA No. _____

Mark the package: Returned for Repair

Model No. _____

17.3 NON-WARRANTY REPAIR.

The following is the procedure for returning for repair instruments that are no longer under warranty:

1. Call Rosemount Analytical for authorization.
2. Supply the purchase order number, and make sure to provide the name and telephone number of the individual to be contacted should additional information be needed.
3. Do Steps 3 and 4 of Section 17.2.

NOTE

Consult the factory for additional information regarding service or repair.

APPENDIX A

BAROMETRIC PRESSURE AS A FUNCTION OF ALTITUDE

The table shows how barometric pressure changes with altitude. Pressure values do not take into account humidity and weather fronts.

Altitude		Barometric Pressure			
m	ft	bar	mm Hg	in Hg	kPa
0	0	1.013	760	29.91	101.3
250	820	0.983	737	29.03	98.3
500	1640	0.955	716	28.20	95.5
750	2460	0.927	695	27.37	92.7
1000	3280	0.899	674	26.55	89.9
1250	4100	0.873	655	25.77	87.3
1500	4920	0.846	635	24.98	84.6
1750	5740	0.821	616	24.24	82.1
2000	6560	0.795	596	23.47	79.5
2250	7380	0.771	579	22.78	77.1
2500	8200	0.747	560	22.06	74.7
2750	9020	0.724	543	21.38	72.4
3000	9840	0.701	526	20.70	70.1
3250	10,660	0.679	509	20.05	67.9
3500	11,480	0.658	494	19.43	65.8

WARRANTY

Seller warrants that the firmware will execute the programming instructions provided by Seller, and that the Goods manufactured or Services provided by Seller will be free from defects in materials or workmanship under normal use and care until the expiration of the applicable warranty period. Goods are warranted for twelve (12) months from the date of initial installation or eighteen (18) months from the date of shipment by Seller, whichever period expires first. **Consumables, such as glass electrodes, membranes, liquid junctions, electrolyte, o-rings, catalytic beads, etc., and Services are warranted for a period of 90 days from the date of shipment or provision.**

Products purchased by Seller from a third party for resale to Buyer ("Resale Products") shall carry only the warranty extended by the original manufacturer. Buyer agrees that Seller has no liability for Resale Products beyond making a reasonable commercial effort to arrange for procurement and shipping of the Resale Products.

If Buyer discovers any warranty defects and notifies Seller thereof in writing during the applicable warranty period, Seller shall, at its option, promptly correct any errors that are found by Seller in the firmware or Services, or repair or replace F.O.B. point of manufacture that portion of the Goods or firmware found by Seller to be defective, or refund the purchase price of the defective portion of the Goods/Services.

All replacements or repairs necessitated by inadequate maintenance, normal wear and usage, unsuitable power sources, unsuitable environmental conditions, accident, misuse, improper installation, modification, repair, storage or handling, or any other cause not the fault of Seller are not covered by this limited warranty, and shall be at Buyer's expense. Seller shall not be obligated to pay any costs or charges incurred by Buyer or any other party except as may be agreed upon in writing in advance by an authorized Seller representative. All costs of dismantling, reinstallation and freight and the time and expenses of Seller's personnel for site travel and diagnosis under this warranty clause shall be borne by Buyer unless accepted in writing by Seller.

Goods repaired and parts replaced during the warranty period shall be in warranty for the remainder of the original warranty period or ninety (90) days, whichever is longer. This limited warranty is the only warranty made by Seller and can be amended only in a writing signed by an authorized representative of Seller. Except as otherwise expressly provided in the Agreement, THERE ARE NO REPRESENTATIONS OR WARRANTIES OF ANY KIND, EXPRESS OR IMPLIED, AS TO MERCHANTABILITY, FITNESS FOR PARTICULAR PURPOSE, OR ANY OTHER MATTER WITH RESPECT TO ANY OF THE GOODS OR SERVICES.

RETURN OF MATERIAL

Material returned for repair, whether in or out of warranty, should be shipped prepaid to:

**Emerson Process Management
Rosemount Analytical
2400 Barranca Parkway
Irvine, CA 92606**

The shipping container should be marked:

Return for Repair

Model _____

The returned material should be accompanied by a letter of transmittal which should include the following information (make a copy of the "Return of Materials Request" found on the last page of the Manual and provide the following thereon):

1. Location type of service, and length of time of service of the device.
2. Description of the faulty operation of the device and the circumstances of the failure.
3. Name and telephone number of the person to contact if there are questions about the returned material.
4. Statement as to whether warranty or non-warranty service is requested.
5. Complete shipping instructions for return of the material.

Adherence to these procedures will expedite handling of the returned material and will prevent unnecessary additional charges for inspection and testing to determine the problem with the device.

If the material is returned for out-of-warranty repairs, a purchase order for repairs should be enclosed.

EC Declaration of Conformity



We, Emerson Process Management, Blegistrasse 21, Barr, Switzerland CH 6341 declare under our sole responsibility that the product,

5081-A-HT-60 Amperometric Transmitter, HART;
5081-P-HT-60 pH Transmitter, HART;
5081-A-FF-60 Amperometric Transmitter, Fieldbus;
5081-P-FF-60 pH Transmitter, Fieldbus;
5081-A-FI-60 Amperometric Transmitter, FISCO;
5081-P-FI-60 pH Transmitter, FISCO

manufactured by, Emerson Process Management, Rosemount Analytical
 2400 Barranca Parkway, Irvine, California 92606 USA

to which this declaration relates, is in conformity with the provisions of the European Community directive, including the latest amendments, as listed below.

Assumption of conformity is based on the application of the harmonized standards.

 (signature)

Vice President Analytical Europe
 (function name printed)

Andy Kemish
 (name printed)

October 1, 2012
 (date of issue)

EMC Directive (2004/108/EC)

5081-A-HT-60, 5081-P-HT-60 (HART)
5081-A-FF-60, 5081-P-FF-60 (Fieldbus)
5081-A-FI-60, 5081-P-FI-60 (FISCO Fieldbus)

Harmonized standard used: EN 61326-1: 2006

EC Declaration of Conformity



We, Emerson Process Management, Blegistrasse 21, Barr, Switzerland CH 6341 declare under our sole responsibility that the product,

5081-A-HT Amperometric Transmitter, HART;
5081-P-HT pH Transmitter, HART;
5081-A-FF-73 Amperometric Transmitter, Fieldbus;
5081-P-FF-73 pH Transmitter, Fieldbus;
5081-A-FI-73 Amperometric Transmitter, FISCO;
5081-P-FI-73 pH Transmitter, FISCO

manufactured by, Emerson Process Management, Rosemount Analytical
 2400 Barranca Parkway, Irvine, California 92606 USA

to which this declaration relates, is in conformity with the provisions of the European Community directives, including the latest amendments, as listed below.

Assumption of conformity is based on the application of the harmonized standards and, when applicable or required, a European Community notified body certification, as shown below.

 (signature)

Vice President Analytical Europe
 (function name printed)

Andy Kemish
 (name printed)

October 2, 2012
 (date of issue)

EMC Directive (2004/108/EC)

5081-A-HT, 5081-P-HT (HART)
5081-A-FF-73, 5081-P-FF-73 (Fieldbus)
5081-A-FI-73, 5081-P-FI-73 (FISCO Fieldbus)

Harmonized standard used: EN 61326-1: 2006

ATEX Directive (94/9/EC)

Provisions of the directive fulfilled by the equipment:

Equipment Group II, Category 1 G Ex ia IIC T4 Ga (-20°C ≤ Ta ≤ +65°C)
5081-A-HT, 5081-P-HT (HART)
5081-A-FF-73, 5081-P-FF-73 (Fieldbus)
5081-A-FI-73, 5081-P-FI-73 (FISCO Fieldbus)

BAS02A TEX1294X -- Intrinsically Safe Certificate

Harmonized standards used: EN 60079-0:2009 EN 60079-11:2007

Special condition for safe use:

The apparatus enclosure may contain light metals. The apparatus must be installed in such a manner as to minimize the risk of impact or friction with other metal surfaces.

ATEX Notified Body for EC Type Examination Certificate & Quality Assurance:
 Baseefa [Notified Body Number: 1180], Rockhead Business Park, Sladen Lane
 Buxton, Derbyshire SK17 9RZ, United Kingdom

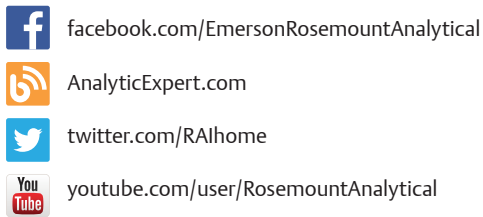

Credit Cards for U.S. Purchases Only.



Emerson Process Management

2400 Barranca Parkway
Irvine, CA 92606 USA
Tel: (949) 757-8500
Fax: (949) 474-7250
rosemountanalytical.com

© Rosemount Analytical Inc. 2015

©2015 Rosemount Analytical, Inc. All rights reserved.

The Emerson logo is a trademark and service mark of Emerson Electric Co. Brand name is a mark of one of the Emerson Process Management family of companies. All other marks are the property of their respective owners.

The contents of this publication are presented for information purposes only, and while effort has been made to ensure their accuracy, they are not to be construed as warranties or guarantees, express or implied, regarding the products or services described herein or their use or applicability. All sales are governed by our terms and conditions, which are available on request. We reserve the right to modify or improve the designs or specifications of our products at any time without notice.