

Rosemount™ 326T Temperature Transmitter

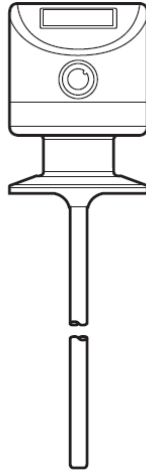

Contents

Chapter 1	Introduction.....	5
	1.1 Functions and features.....	5
Chapter 2	Installation.....	7
	2.1 Mounting the transmitter.....	7
	2.2 Connect the transmitter.....	7
Chapter 3	Operation.....	9
	3.1 Display elements.....	9
	3.2 Parameter settings.....	9
	3.3 Adjustable parameters.....	10
	3.4 Operating modes.....	10
Chapter 4	Temperature resistance.....	11
Chapter 5	Product certifications.....	13
	5.1 European directive information.....	13
	5.2 Ordinary location information.....	13
	5.3 3-A [®] certification.....	13
	5.4 Other industry certifications.....	13
Chapter 6	Factory settings.....	15

1 Introduction

The Rosemount 326T Temperature Transmitter detects media temperature and converts it into an analog output signal (4 - 20 mA).

1.1 Functions and features

The temperature transmitter converts the measured signal into a temperature-proportional analog signal. Depending on the parameter setting, the output signal is:

- 4-20 mA with setting OU = I
- 20-4 mA with setting OU = Ineg

The temperature transmitter can scale the analog signal to accommodate the application. For more technical data, see the Rosemount™ 326T Temperature Transmitter Product Data Sheet or Emerson.com/Rosemount.

Maximum measuring range when OU = I

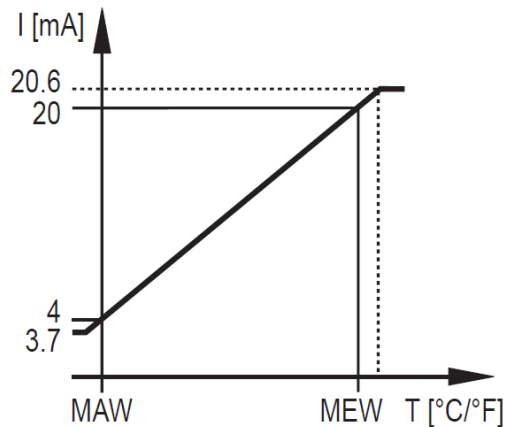

Measuring range scaled when OU = I

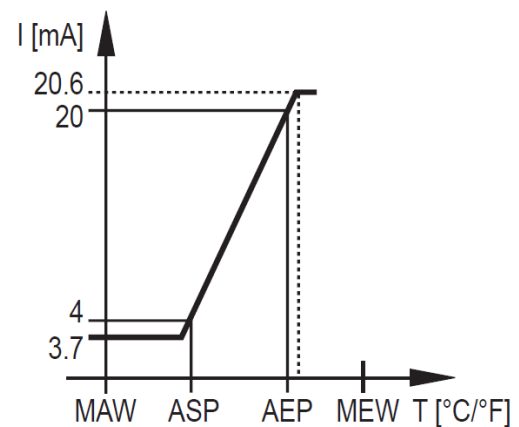

- MAW = initial value of the measuring range
- MEW = final value of the measuring range
- ASP = analog start point
- AEP = analog end point

Note

The minimum difference between ASP and AEP is 9 °F (5 °C).

If the temperature is within the measuring range, the output signal is between 4-20 mA. If the temperature is outside the measuring range, the output signal is between these ranges:

Temperature condition	Output signal when OU = I	Output signal when OU = Ineg
Temperature > AEP	20-20.6 mA	4-3.7 mA
Temperature > MEW	20.6 mA	3.7 mA
Temperature < ASP	4-3.7 mA	20-20.6 mA

Temperature condition	Output signal when OU = I	Output signal when OU = Ineg
Temperature < MAW	3.7 mA	20.6 mA

Note

In a fault condition, the output signal reacts according to the FOU parameter.

2 Installation

This section provides instructions for mounting and connecting the temperature transmitter.

2.1 Mounting the transmitter

Follow these instructions to mount the temperature transmitter.

Note

If installing in a 3-A compliant environment, follow 3-A standards for installation.

Procedure

1. Position the transmitter to the desired orientation.
2. Install the clamp following recommended torque values provided by the clamp manufacturer.

2.2 Connect the transmitter

Follow these instructions to connect the temperature transmitter for two-wire or four-wire operations.

⚠ CAUTION

- A certified electrician must wire the temperature transmitter.
- Adhere to national and international regulations when wiring the temperature transmitter.

Voltage supply to EN 50178, SELV, PELV / "supply class 2" to cULus.

Procedure

1. Disconnect power from the temperature transmitter.
2. Connect the temperature transmitter according to these wiring diagrams.

Figure 2-1: Two-wire operation

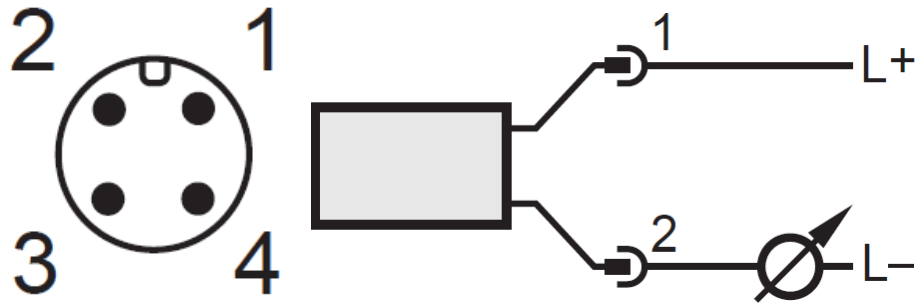

- Pin 1 L+
- Pin 2 Analog signal for temperature

Figure 2-2: Four-wire operation

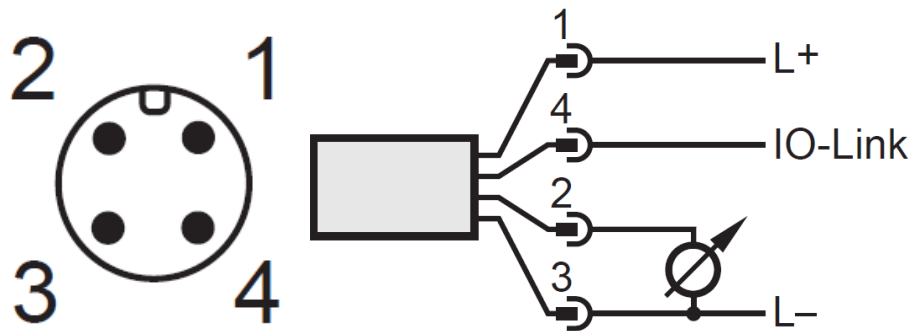

- Pin 1 L+
- Pin 2 Analog signal for temperature
- Pin 3 L-
- Pin 4 IO-Link

3 Operation

This section provides information for using the temperature transmitter.

3.1 Display elements

The front of the temperature transmitter includes an alphanumeric display and LED indicators.

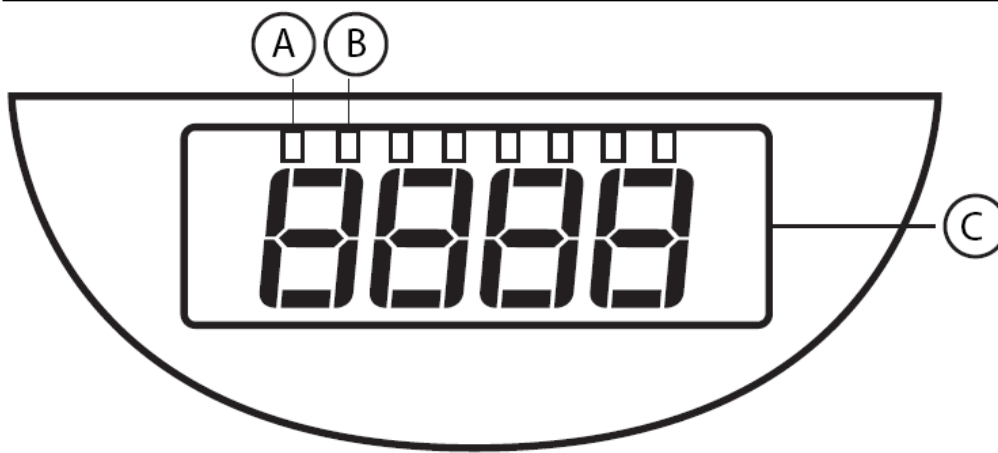

- A. Current temperature in °C
- B. Current temperature in °F
- C. Seven-segment LED display (4 digits)

3.2 Parameter settings

Use an IO-Link capable tool to read current process values and modify parameter values.

3.2.1 General information

The temperature transmitter uses an IO-Link communication interface that requires an IO-Link master for operation.

IO-Link enables direct access to process and diagnostic data and allows the setting of parameter values.

3.2.2 IO-Link information

The IODDs necessary for configuring the IO-Link device, detailed information about process data structure, diagnostic information, parameter addresses and the necessary

information about the required IO-Link hardware and software are available at Emerson.com/Rosemount

3.3 Adjustable parameters

Use IO-Link software to configure these parameters.

Parameter	Description
OU2	Output function: analog signal is 4-20 mA (I) or 20-4 mA (Ineg)
ASP2	Analog start point for the measured temperature value.
AEP2	Analog end point for the measured temperature value. The minimum difference between ASP2 and AEP2 is 9 °F (5 °C).
COF	Zero point calibration. Offsets the zero point ± 18 °F in steps of .18 °F (± 10 °C in steps of 0.1 °C).
FOU2	Behavior of the output after a fault. <ul style="list-style-type: none"> • ON: the analog signal is driven to 21.1 mA. • OFF: the analog signal is driven to 3.5 mA.
Uni	Sets the temperature unit in °F or °C.
Update rate of display	The rate at which the transmitter updates the displayed temperature measurement. <ul style="list-style-type: none"> • d1: 50 ms • d2: 200 ms • d3: 600 ms
Orientation of display	rd: rotates the display by 180°.

3.4 Operating modes

The temperature transmitter uses different operating modes depending on the measured temperature.

After turning on the temperature transmitter the temperature transmitter displays the current measured temperature and the analog output provides a signal proportional to the measured temperature.

If the temperature is outside of the measuring range the temperature transmitter displays OL or UL.

4 Temperature resistance

This graph shows the reduction of maximum operation time based on process temperature.

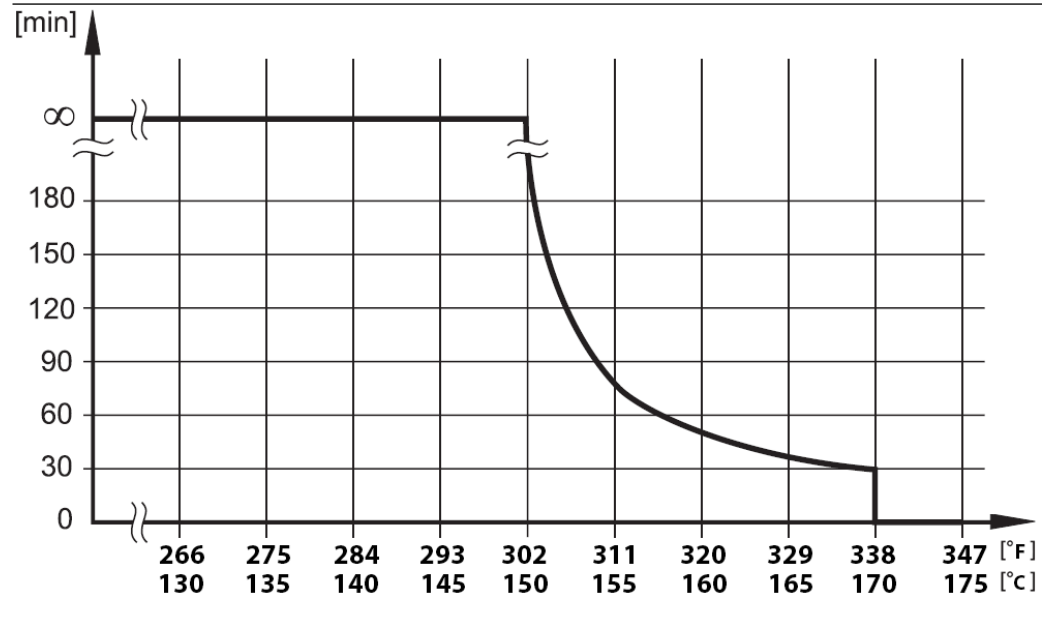

5 Product certifications

5.1 European directive information

The most recent revision of the EC Declaration of Conformity can be found at Emerson.com/Rosemount.

5.2 Ordinary location information

As standard, this product has been examined and tested to determine that the design meets the basic electrical, mechanical, and fire protection requirements by a nationally recognized test laboratory (NRTL) as accredited by the Federal Occupational Safety and Health Administration (OSHA).

Voltage supply to EN 50178, SELV, PELV / "supply class 2" to cULus.

5.3 3-A[®] certification

This product is authorized to display the 3-A symbol. Ensure gaskets and process connection accessories selected for installation meet both the application and 3-A requirements. A certificate of compliance is available at Emerson.com/Rosemount.

5.4 Other industry certifications

All Rosemount 326T transmitter surfaces and materials which come into contact with process medium comply with the following regulations:

6 Factory settings

Use this worksheet to reference factory default settings and record user-modified settings.

Parameter	Factory default setting	User-defined setting
OU	I	
COF	0.0	
FOU	OFF	



00825-0100-4328

Rev. 01

2019

Global Headquarters

Emerson Automation Solutions
6021 Innovation Blvd
Shakopee, MN 55379, USA

 +1 800 999 9307 or +1 952 906 8888

 +1 952 949 7001

 RFQ.RMD-RCC@Emerson.com

North America Regional Office

Emerson Automation Solutions
8200 Market Blvd.
Chanhassen, MN 55317, USA

 +1 800 999 9307 or +1 952 906 8888

 +1 952 949 7001

 RMT-NA.RCCRF@Emerson.com

 [Linkedin.com/company/Emerson-Automation-Solutions](https://www.linkedin.com/company/Emerson-Automation-Solutions)

 [Twitter.com/Rosemount_News](https://twitter.com/Rosemount_News)

 [Facebook.com/Rosemount](https://www.facebook.com/Rosemount)

 [Youtube.com/user/RosemountMeasurement](https://www.youtube.com/user/RosemountMeasurement)

©2019 Emerson. All rights reserved.

Emerson Terms and Conditions of Sale are available upon request. The Emerson logo is a trademark and service mark of Emerson Electric Co. Rosemount is mark of one of the Emerson family of companies. All other marks are the property of their respective owners.

ROSEMOUNT™

