

Rosemount™ 326L Level Transmitter



Contents

Chapter 1	Introduction.....	5
	1.1 Safety instructions.....	5
	1.2 Applications.....	5
	1.3 Measuring principle.....	6
	1.4 Outputs.....	7
	1.5 IO-Link.....	8
	1.6 Functions.....	8
Chapter 2	Installation.....	13
	2.1 Installation considerations.....	13
	2.2 Installing the level transmitter.....	17
	2.3 Wire the transmitter.....	22
Chapter 3	Operation.....	25
	3.1 Display elements.....	25
	3.2 Menu structure.....	26
	3.3 Parameter settings.....	29
	3.4 Setup the level transmitter.....	30
	3.5 Using the transmitter.....	38
	3.6 Setting parameters with IO-Link.....	40
Chapter 4	Troubleshooting and maintenance.....	43
	4.1 Error indicators.....	43
	4.2 Output response in different operating states.....	43
	4.3 Maintenance.....	44
Chapter 5	Setting ranges.....	47
Chapter 6	Product certifications.....	49
	6.1 European directive information.....	49
	6.2 Ordinary location information.....	49
	6.3 3-A [®] certification.....	49
	6.4 Other industry certifications.....	49
Chapter 7	Factory settings.....	51

1 Introduction

The level transmitter continuously detects level of a media and reports the level of the media in multiple selectable units of measurements and values.

1.1 Safety instructions

Follow these safety guidelines when installing and using the level transmitter.

⚠ CAUTION

- Read this document before installing the level transmitter and keep it for the life of the level transmitter.
- The level transmitter must be suitable for the corresponding applications and environmental conditions without any restrictions.
- Use the level transmitter only for its intended purpose.
- Use the level transmitter only with permissible media.
- If you do not adhere to the operating instructions and technical data, personal injury and/or damage to property might occur.
- The manufacturer assumes no liability or warranty for any consequences caused by tampering with the product or incorrect use by the operator.
- Installation, electrical connection, set-up, operation and maintenance of the product must be performed by qualified personnel authorized by the machine operator.
- Protect units and cables against damage.

1.2 Applications

The level transmitter is intended to be used in food and beverage applications or applications with significant hygienic requirements.

The level transmitter complies with the standard EN 61000-6-4 and is a class A product. The level transmitter may cause radio interference in domestic areas. If interference occurs, the user must take appropriate actions.

Note

The level transmitter emits less microwave energy than mobile phones. The operation of the level transmitter is harmless to human health if used as intended.

1.2.1 Application area restrictions

Measurements made by the level transmitter can be impacted by the environment and the type of media it is measuring.

The following media characteristics can cause incorrect measurements:

- Highly absorbing surfaces (foam)
- Intensely bubbling surfaces
- Media which are very inhomogeneous, separate from each other thus forming separation layers (oil layer on water)

To prevent this, follow these guidelines:

- Check the function by performing an application test.
- Install the level transmitter in a steady environment.

In case of signal loss, the level transmitter displays SENS and switches the outputs to a defined state. See [Output response in different operating states](#) for more information.

The level transmitter is not suitable for:

- Bulk materials like plastic granulates and media with a very low dielectric constant like oils.
- Applications where the probe is subjected to permanent and high mechanical stress. For example, fast moving viscous medium or fast flowing medium.

Use the level transmitter preferably with metal tanks. When used with plastic tanks, deterioration caused by electromagnetic interference might occur (noise immunity to EN61000-6-2).

1.3 Measuring principle

The level transmitter uses guided wave radar to measure media level. It emits electromagnetic pulses every nanosecond to measure the level.

Figure 1-1: Transmitting Pulses

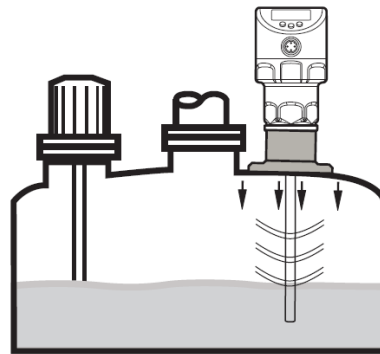
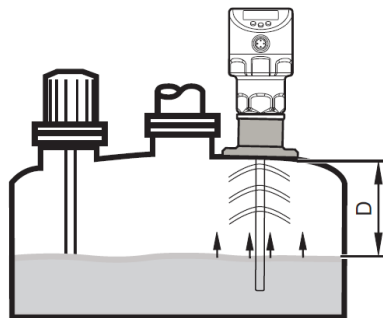

Figure 1-2: Receiving Pulses



The transmitter head transmits pulses that are guided along the probe towards the media (Figure 1-2). When the pulses hit the media they are reflected and guided back to the transmitter (Figure 1-2). The time between transmitting and receiving the pulse determines the traveled distance (D) and the current level. The reference for distance measurement is the lower edge of the process connection.

1.3.1 Probes for different tank heights

The height of the probe must be adjusted to accommodate the height of the tank. Probes at different heights are available to order. The minimum probe length is 1.18 inches (150 mm). The maximum probe length 78.74 in (2000 mm).

1.4 Outputs

The level transmitter generates output signals based on the output parameter settings. Two outputs are available and they can be set separately.

OUT1

OUT1 provides a switching signal for level limit or IO-Link communication. See [IO-Link](#) for more information.

OUT2

OUT2 can perform one of these functions:

- An analog signal proportional to the level 4 - 20 mA or 20 - 4 mA
- Switching signal for level limit

1.4.1 Fault states

Defined states for each output prepare the output for fault conditions. If the level transmitter detects a fault or if the signal quality is below a minimum value, the transmitter outputs change to the defined fault state.

Use FOU1 and FOU2 to configure fault states for the respective outputs. Fault states for the analog output follow Namur recommendation (NE43). For more information, see [Set response of the outputs in case of fault](#).

Setting a delay time prevents the level transmitter from erroneously falling into a fault state. For more information, see [Set delay time in case of a fault](#). During the delay time, the level transmitter retains the last measured value. If the measured signal is received again in sufficient strength within the delay time, the unit continues to work in normal operation. If it is not received again in sufficient strength within the delay time, the outputs change to the defined state.

Note

In case of heavy foam build-up or turbulence, create a steady environment for the level transmitter. For more information, see [Minimum distances and connection piece diameter](#).

1.5 IO-Link

The level transmitter has an IO-Link communication interface which requires an IO-Link-capable module (IO-Link master) for operation.

The IO-Link interface enables direct access to the process and diagnostic data and provides the possibility to set the parameters of the unit during operation.

Point-to-point connection is possible with a USB adapter cable.

Detailed information about process data structure (IODDs) necessary for the configuration of the level transmitter, diagnostic information, parameter addresses, and the necessary information about the required IO-Link hardware and software can be found at Emerson.com/Rosemount.

1.6 Functions

The level transmitter performs the functions detailed in this section.

1.6.1 Display functions

The level transmitter displays the current level, either in millimeters, inches, or percentage of the scaled measuring range. The default factory setting is inches.

For more information on changing the displayed unit of measurement, see [Configure the display](#).

In the operating mode, you can switch between length display (mm, inch) and percentage. For more information, see [Change display between length and percentage](#).

The LEDs indicate the set unit of measurement and the switching status of the outputs. For more information, see [Display elements](#).

1.6.2 Analog signal

The level transmitter can provide an analog signal proportional to level.

The parameter ou2 defines the output function for the analog output:

- 4-20 mA (ou2 = I)
- 20-4 mA (ou2 = InEG)

For more information, see [Set output function for OUT2](#).

The analog start point ASP2 defines the measured value at which the analog start value is provided. The analog start value is 4 mA with $ou2 = I$ or 20 mA with $ou2 = InEG$. For more information, see [Scale analog signal](#).

The analog end point AEP2 defines the measured value at which the analog end value is provided. The analog end value is 20 mA with $ou2 = I$ or 4 mA with $ou2 = InEG$. For more information, see [Scale analog signal](#).

The minimum distance between ASP2 and AEP2 is 20 percent of the active zone.

Figure 1-3: Analog signal

The default factory curve of the analog signal:

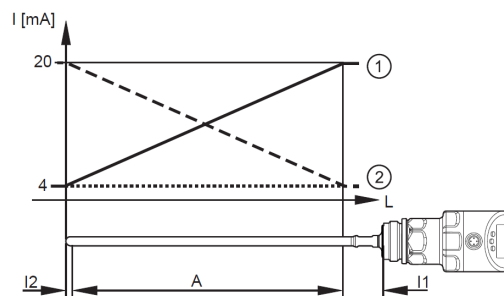

L: Level
A: Active zone = $L - (I1 + I2)$
I1: Inactive zone 1
I2: Inactive zone 2

A scaled measuring range curve of the analog signal:

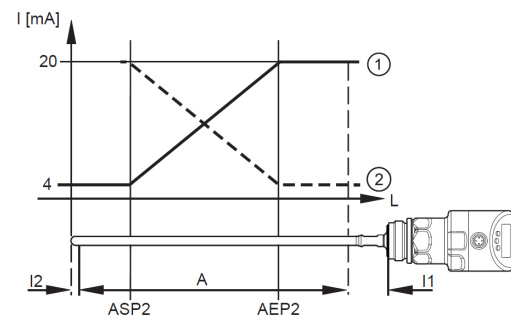

1: $ou2 = I$ (factory setting)
2: $ou2 = InEG$
ASP2: Analog start point
AEP2: Analog end point

For more information about the analog output, see [Output response in different operating states](#).

Take note of the tolerances and accuracy limits during the evaluation of the analog signal. For more information, see the Product Data Sheet.

1.6.3 Switching functions

When using a switching output (OUT1 or OUT2), the level transmitter indicates when the level reaches a set limit or that the level is below the limit.

Select one of the following switching functions for the outputs:

- Hysteresis function/normally open: $oux = Hno$
- Hysteresis function/normally closed: $oux = Hnc$

Note

When configuring a switching function, set the set point (SPx) first, then set the reset point (rPx) with the requested difference.

- Window function/normally open: $oux = Fno$

- Window function/normally closed: oux = Fnc

Note

The difference between FHx and FLx sets the width of the window. FHx is the upper value and FLx is the lower value.

Figure 1-4: Switching function

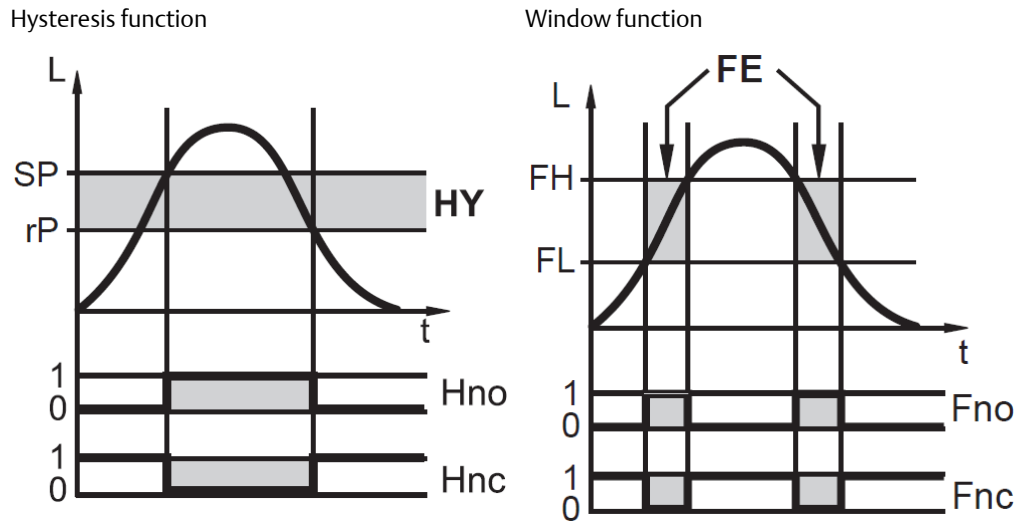

L: Level

HY: Hysteresis

FE: Window

- The adjustable limits (SP and rP) always refer to the lower edge of the probe.
- The maximum switch-on and switch-off delay for the switching output is 60 seconds. For more information, see [Set switch-on delay for switching outputs](#) and [Set switch off delay for switching outputs](#).

1.6.4 Damping function

If the medium conditions are unsteady, dampen the transmitter response. The level transmitter uses a filter to smooth the values into a steady curve when the display and output response is dampened.

You can configure the damping using dAP. For more information, see [Set damping for measured signal](#).

In the event of a sudden jump in level, dAP indicates the time in seconds for the output to reach 63 percent of the final value. After five times dAP, the output should reach 100 percent of the final value.

1.6.5 Simulation functions

To assist in maintenance, reducing interference, or setting up the level transmitter, simulate error scenarios and levels.

The duration of a simulation can be between one minute and one hour. The simulation is started manually and runs until the set duration elapses. During the simulation, the outputs respond according to the simulated process values. For more information, see [Simulation](#).

2 Installation

This section includes instructions for installing and wiring the level transmitter.

These procedures are required to setup the level transmitter:

1. [Installing the level transmitter](#)
2. [Wire the transmitter](#)
3. [Adjust the probe length](#)

To modify the factory default settings, perform these procedures.

- [Set parameters](#)
- [Perform a tank adjustment](#)
- [Change basic settings](#)

To view the factory default settings, see [Factory settings](#). Test that the level transmitter is working correctly before using.

2.1 Installation considerations

Follow these installation guidelines to ensure more effective operation of the level transmitter.

- For more effective level measurement, install the level transmitter vertically on the top of the tank or pipe.
- To reduce signal interference, perform a tank adjustment (see [Tank adjustment](#)).
- For more effective level measurement, install the level transmitter in closed, metal tanks or bypass pipes.
 - For installation instructions for open tanks, see [Installing in an open tank](#).
 - For installation instructions for plastic containers, see [Installing in a plastic tank](#).

2.1.1 Minimum distances and connection piece diameter

For more effective operation, follow these guidelines for the connection piece diameter and the distances between the level transmitter and the tank.

Select a connection piece height that is smaller than the connection piece diameter.

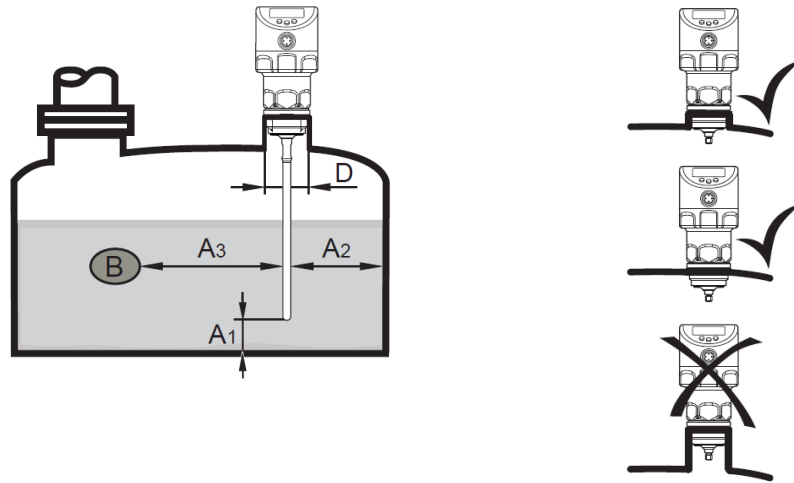

Installation distances with adjustment
 A1: 0.39 in (10 mm)
 A2: 0.79 in (20 mm)
 A3: 0.79 in (20 mm) to tank structures (B) 1.97 in (50 mm) to other transmitters type LR
 D: \varnothing 1.18 in (30 mm) if installed in a connection piece

Installation distances without adjustment
 A1: 0.39 in (10 mm)
 A2: 1.97 in (50 mm)
 A3: 1.97 in (50 mm) to tank structures (B) 1.97 in (50 mm) to other transmitters type LR
 D: No connection piece allowed (see above image)

2.1.2 Installation in pipes

If installing the level transmitter in a pipe, the conditions must meet these requirements.

- Hygienic requirements
- Install only in metal pipes
- The internal diameter of the pipe (d) must meet these requirements:

	With adjustment	Without adjustment
d	\varnothing 1.18 in (30 mm)	\varnothing 3.94 in (100 mm) with [MEdI] = [HIGH] \varnothing 7.87 in (250 mm) with [MEdI] = [Mid] For more information, see Set to another medium.

Note

Using a centering piece can prevent damage caused by turbulent media by stabilizing the probe.

2.1.3 Applications with viscous or fast-flowing media

The installation of the level transmitter must meet the following requirements if installed in conditions with viscous or fast-flowing media and/or agitators.

- The probe cannot contact the tank walls or structures.
- Expect an increase in the minimum lateral distances according to probe length and the lateral deflection.
- If possible, use a sleeve or a similar device to fix the probe at the lower end so that it is electrically conductive. See [Figure 2-1](#)

Figure 2-1: Installation with Viscous or Fast-Flowing Media

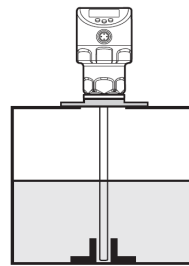

- Ensure the correct function is set. (Especially in use with an empty tank)

2.1.4 Fill openings

Do not install the level transmitter near or in contact with a fill opening.

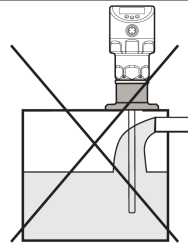

2.1.5 Highly polluted medium

If the medium is highly polluted, there is a risk that a bridge forms between the probe and the tank wall or structures in the tank.

To avoid this, increase minimum distance between the probe and the tank walls depending on the pollution intensity.

2.1.6 Heavy foam build-up and turbulence

Heavy foam build-up or turbulence in the tank might cause incorrect measurements.

To avoid this, install the transmitter in a steady area that meets hygienic requirements.

Examples of how to create a steady environment include:

- Install the level transmitter in a metal bypass or a metal still pipe.
- Separate the level transmitter location with metal sheets or perforated sheets.

Figure 2-2: Installing in foam build-up and turbulence

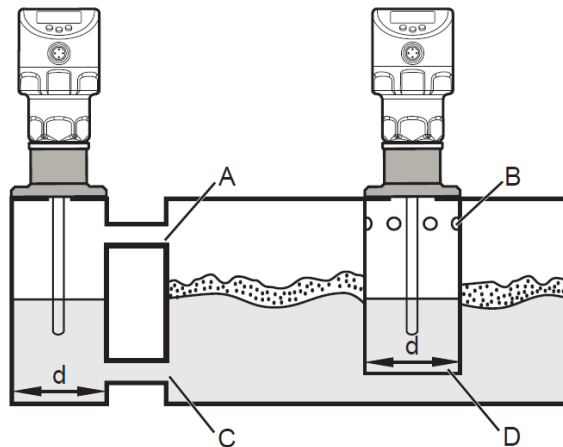

d: Minimum diameter (See [Installation in pipes](#))

Note

The upper access to the steady area (A, B) must be above the maximum level. The lower access (C, D) or the area with perforated sheet must be below the minimum level. This ensures that neither foam nor turbulence impact the transmitter zone. To avoid interference from solids in the medium, use perforated sheets or something similar.

Note

With increased foam build-up set the medium parameter [MEdI] to [MIId]. For instructions, see [Set to another medium](#).

2.1.7

Tank adjustment

Tank adjustment reduces interference and ensures a higher excess gain in difficult application conditions.

⚠ CAUTION

Perform a tank adjustment only after installing the level transmitter.

- When performing a tank adjustment, enter an adjustment distance first. Starting from the process connection, use the adjustment distance to compensate for interfering reflections.
- Select an adjustment distance (a) so the level transmitter can detect the connection piece (S) and structures in the tank (B).
- Observe safety distance ($b \geq 9.84$ in (250 mm)) to the level or the probe end.

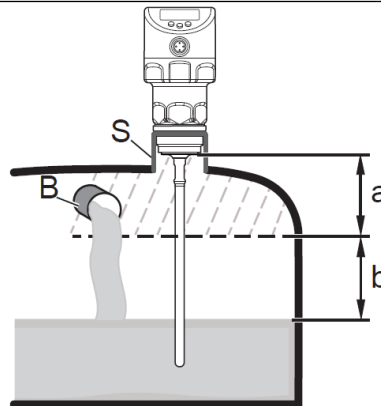

a: Minimum adjustment distance is 0.39 in (10 mm); maximum is $L - 9.84$ in (250 mm)

b: Safety distance to the level or probe end: $b \geq 9.84$ in (250 mm)

S: Connection piece

B: Structures in the tank

- For probe lengths $L < 10.24$ in (260 mm), tank adjustment is not possible. tREF is then not available. In this case, adhere to all installation distances in [Installation considerations](#).
- If the installation meets all distance guidelines, a tank adjustment is not necessary.
- If possible, perform the tank adjustment on an empty tank to detect any possible sources of interference. In this case, select the maximum adjustment distance ($L - 9.84$ in or $L - 250$ mm).
- Tank adjustment information is not saved with IO-Link. After a replacement, perform a tank adjustment again. For more information on data storage, see [Unit locking and data storage](#).

2.2 Installing the level transmitter

Follow these instructions to install the level transmitter.

2.2.1 Adjust the probe length

If needed, modify the standard probe length to accommodate the height of the tank.

Note

- The level transmitter does not support probe lengths less than 5.91 in (150 mm).
- Tank adjustment is not possible with probe lengths of less than 10.24 in (260 mm). For more information, see [Tank adjustment](#).

Procedure

1. Screw the probe to the level transmitter.

2. Mark the desired length (L) on the probe. The reference point is the lower edge of the process connection.

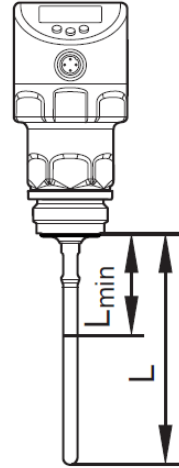

3. Remove the probe from the unit. Do not lose the O-ring between the probe attachment piece and the probe.
4. Shorten the probe at the mark.
5. Remove all burrs and sharp edges. For hygienic requirements: Restore the required surface quality. If necessary, polish the probe.

Note

In cases with strong vibrations or moving viscous medium, it may be necessary to secure the probe connection using screw retaining compound. In this case, ensure that the compound is harmless because it might migrate into the medium.

Postrequisites

Reinstall the probe by following the steps in [Install the probe](#).

2.2.2 Install the probe

Install the probe onto the level transmitter to ensure accurate level readings.

For more information, see [Measuring principle](#).

Note

The probe is not included with the level transmitter.

⚠ CAUTION

Do not damage the surfaces of the process connection and probe. Use tools suitable for use with plastic surfaces.

Procedure

1. Remove the protective cover and protective devices from the unit and the probe.

2. Slip the supplied O-ring onto the probe connection of the unit and check its position.
3. Screw the probe to the unit and tighten it.

Note

Recommended tightening torque: 4.79 ft/lbs (6.5 Nm).

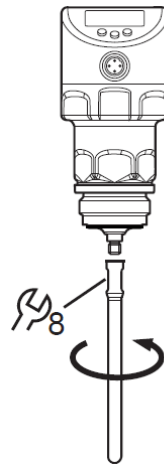

4. Ensure that the O-ring has not moved from its original position. Replace the O-ring if necessary.

Note

In cases with strong vibrations or moving viscous medium, it might be necessary to secure the probe connection using screw retaining compound. In this case, ensure that the compound is harmless because it might migrate into the medium.

5. If the probe length was modified, measure and record the probe length.
 - a) Precisely measure the length of the probe starting from the lower edge of the process connection.
 - b) Record the length of the probe. It is needed for setting up the device parameters.

For more information on setting the length of the probe in the device parameters, see [Enter probe length](#).

2.2.3 Install the level transmitter

Install the level transmitter using these steps. Take note of the different process connections.

⚠ CAUTION

Consider the potential dangers related to extreme machine and medium temperatures.

Prerequisites

Note

Before installing or removing the level transmitter, ensure that no pressure is applied to the system. Also ensure that there is no medium in the tank that might leak during installation.

The level transmitter can be installed using a mounting or welding adapter with a sealing ring. The adapters are supplied with an EPDM o-ring. Further sealing ring materials (FKM) are available. For ordering information, see the transmitter Product Data Sheet. For installation instructions, refer to the instructions included with the mounting adapter.

Note

Certain configurations do not allow alignment of the transmitter housing. With process connections that cannot be aligned, like welding adapters, take into account the final position of the transmitter housing (readability of the display, cable entry). Observe marks on adapters. If needed, screw in the unit and mark the requested alignment.

Procedure

1. Lightly grease the thread of the transmitter using a lubricating paste suitable and approved for the application.
2. Insert the unit into the process connection.
3. Tighten it using a spanner to a torque of 25.8 ft/lbs (35 Nm).

2.2.4 Installing in an open tank

Follow these guidelines when installing the level transmitter in an open tank.

- Use a metal fixture to install the level transmitter to the side of the open tank. It serves as a launching plate (R) for the level transmitter. The minimum size for a square fixture is 5.91 by 5.91 in (150 by 150 mm). The minimum size for a circular fixture is 5.91 in (150 mm) diameter. For more information, see [Operation with a single probe](#).
- If possible, mount the level transmitter in the middle of the fixture. Adhere to the specified installation distances according to [Installation considerations](#). If necessary, perform a tank adjustment.

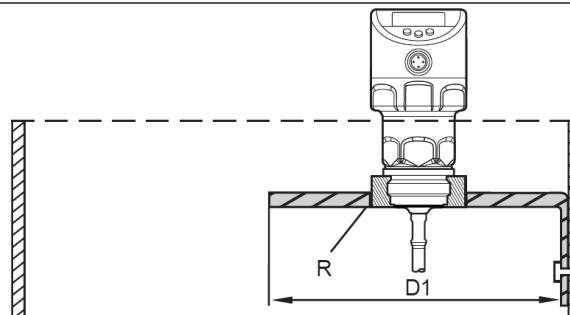

D1: Minimum 5.91 in (150 mm)

R: Launching plate

2.2.5 Installing in a plastic tank

Follow these guidelines when installing the level transmitter in a plastic tank or in a metal tank with a plastic lid.

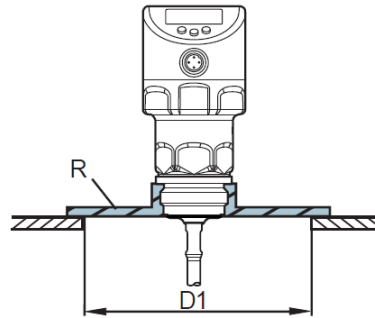

D1: Minimum 5.91 in (150 mm)

R: Launching plate

- The plastic lid must have a drill hole with a minimum diameter of 5.91 in (150 mm).
- Use a metal flange plate or launching plate (R) that sufficiently covers the drill hole. For more information, see [Operation with a single probe](#).
- Ensure that the distance between the probe and the tank wall is at least 3.15 in (80 mm). Adhere to the installation instructions in [Installation considerations](#). If necessary, perform a tank adjustment.

⚠ CAUTION

When installed in plastic tanks, there may be deterioration caused by electromagnetic interference from other devices. Follow these guidelines to avoid deterioration:

- Apply a metal foil to the outside of the tank.
- Apply a shielding screen between the level transmitter and other electronic units.
- Install in a metal pipe only if hygienic requirements are met. For more information, see [Installation considerations](#).

2.2.6 Installing with 3-A[®] standards

The level transmitter is authorized to display the 3-A symbol. Follow these guidelines to ensure 3-A compliance when installing the level transmitter.

- Ensure that the transmitter is installed according to 3-A standards.
- Use the level transmitter only with 3-A certified adapters marked with the 3-A symbol.
- The process connection must have a self-draining leakage port. 3-A certified adapters all have self-draining leakage ports.
- Choose an installation position where the probe and process connection can be cleaned with a spray ball.

Note

According to 3-A standards, special regulations apply for cleaning and maintenance. For more information, see [Cleaning and maintenance in 3-A® applications](#). Not suitable for systems which must meet the criteria of paragraph E1.2 / 63-03 of the 3-A standard 63-03.

2.3 Wire the transmitter

Wire the transmitter according the instructions and illustrations in this topic.

⚠ CAUTION

The level transmitter must be connected by a qualified electrician. Adhere to national and international regulations for the installation of electrical equipment.

Voltage supply according to EN 50178, SELV, PELV.

⚠ CAUTION

This devices requires additional surge protection for marine applications (if approval is available for this device).

Procedure

1. Disconnect power to the level transmitter.
2. Connect the unit according to these diagrams (colors to DIN EN 60947-5-2):

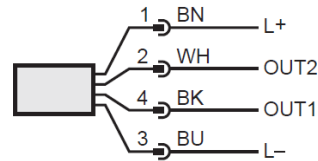
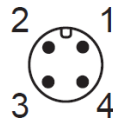

OUT1: switching output / IO-Link

OUT2: analog output / switching output

BK: Black

BN: Brown

BU: Blue

WH: White

Note

After applying operating voltage to the level transmitter for the first time, enter the probe length into the device parameters. After that, the level transmitter is ready for operation. For more information, see [Enter probe length](#).

Example circuits

2 x positive switching

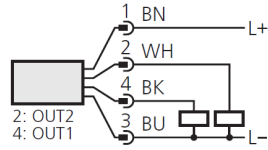

2 x negative switching

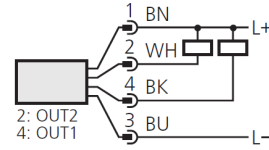

1 x positive switching / 1 x analog

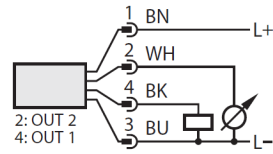

1 x negative switching / 1 x analog

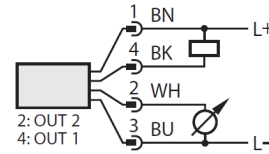

3 Operation

The procedures in this section provide instructions for setting parameters and settings on the level transmitter.

3.1 Display elements

The front of the level transmitter includes LED indicators, buttons, and an alphanumeric display.

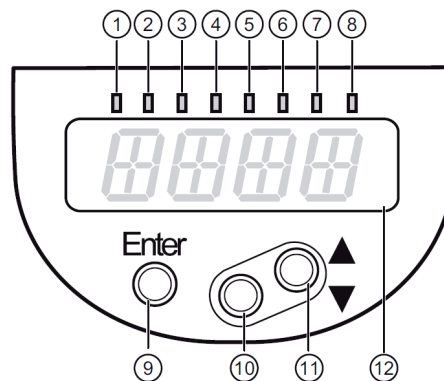

1 to 8: Indicator LEDs	
LEDs 1 - 3	Selected unit of measurement.
LEDs 4 - 6	Not used.
LED 7	Active only if the switching output ou2 = I or InEG is selected; then: switching status OUT2 (on when output 2 is switched).
LED 8	Switching status OUT1 (on when output 1 is switched).
9: Enter button	
Open the user menu, edit and confirm the parameter values.	
10 to 11: Arrow keys up [▲] and down [▼]	
<ul style="list-style-type: none"> • Selection of the parameters • Setting of the parameter values (continuously by holding pressed; incrementally by pressing once). 	
12: Alphanumeric display, four digits	
<ul style="list-style-type: none"> • Display of the current level. • Display of the parameters and parameter values. 	

3.2 Menu structure

The menu provides options for configuring parameters and viewing settings.

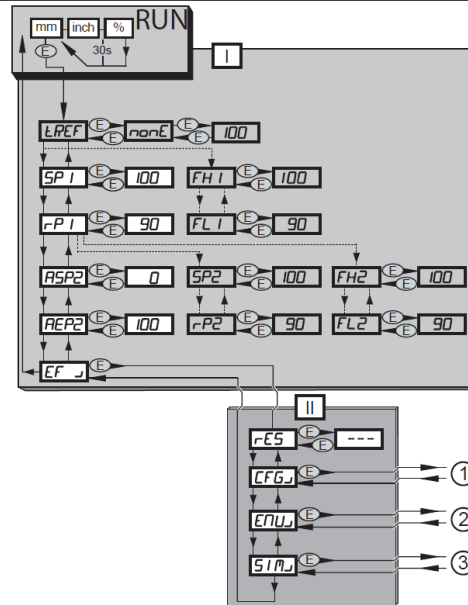

Note

Menu items highlighted in gray are active only after setting assigned parameters.

- I: Main Menu (See [Main menu options](#))
- II: Menu level EF (See [Extended functions menu options \(EF\)](#))

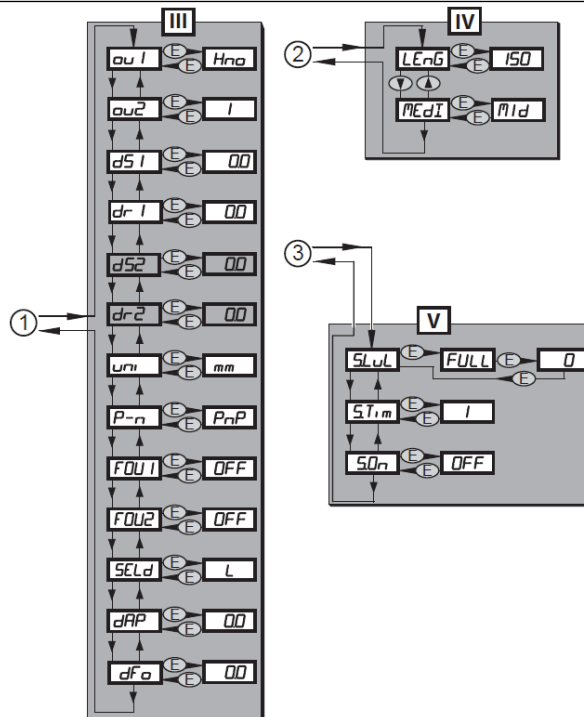

Note

Menu items highlighted in gray are active only after setting assigned parameters.

- III: Level CFG (See [Configuration menu options \(CFG\)](#))
- IV: Level ENV (See [Environment menu options \(ENV\)](#))
- V: Level SIM (See [Simulation menu options \(SIM\)](#))

3.2.1 Main menu options

The main menu includes these options.

Option	Description
tREF	Carry out tank adjustment. Visible only if LEnG \geq 10.24 (260 mm).
SP1/rP1	Set point 1 / reset point 1 at which OUT1 switches. Visible only after selecting hysteresis function (ou1 = H..)
FH1/FL1	Upper / lower limit for the acceptable range within which OUT1 switches. Visible only after selecting window function (ou1 = F..)
ASP2	Analog start point 2: measured value at which the analog start value is provided. The analog start value is set with parameter ou2. Visible only after selecting analog output (ou2 = I or InEG)
AEP2	Analog end point 2: measured value at which the analog end value is provided. The analog end value is set with parameter ou2. Visible only after selecting the analog output (ou2 = I or InEG)

Option	Description
SP2/rP2	Set point 2 / reset point 2 at which OUT2 switches. Visible only after selecting the hysteresis function (ou2 = H..)
FH2/FL2	Upper / lower limit for the acceptable range within which OUT2 switches. Visible only after selecting the window function (ou2 = F..)
EF	Extended functions / opening of menu level 2

3.2.2 Extended functions menu options (EF)

The extended functions menu includes these options.

Option	Description
rES	Restore factory settings (all parameters including tank adjustment)
CFG	Open the configuration menu (CFG)
ENV	Open the environment menu (ENV)
SIM	Open the simulation menu (SIM)

3.2.3 Configuration menu options (CFG)

The configuration menu includes these options.

Option	Description
ou1	Output configuration for OUT1: switching signal for level limit value. Hysteresis or window function, normally closed or normally open
ou2	Output configuration for OUT2: <ul style="list-style-type: none"> analog signal for current level, 4 - 20 mA or 20 - 4 mA Switching signal for level limit. Hysteresis or window function, normally closed or normally open
dS1	Switch-on delay for OUT1
dr1	Switch-off delay for OUT1
dS2 ⁽¹⁾	Switch-on delay for OUT2
dr2 ⁽¹⁾	Switch-off delay for OUT2
uni	Selection of the unit of measurement on the transmitter display; mm or inch
P-n	Output polarity of the switching outputs; positive or negative switching
FOU1	Response of OUT1 in case of a fault
FOU2	Response of OUT2 in case of a fault
SELd	Selection of display options
dAP	Damping of the measured signal (mean filter)

Option	Description
dFo	Delay time for the outputs to pass into the state defined with FOUx; only effective in case of a fault

(1) Visible only after selecting hysteresis or window function (ou2 = H.. or F..).

3.2.4 Environment menu options (ENV)

The environment menu includes these options.

Option	Description
LEnG	Input of the probe length
MEdI	Medium selection

3.2.5 Simulation menu options (SIM)

The simulation menu includes these options.

Option	Description
S.LvL	Simulation of a level or an error state
S.Tim	Simulation duration 1 - 60 minutes
S.On	Simulation start/stop

3.3 Parameter settings

The level transmitter remains in operating mode while setting new parameters. It continues to monitor using the existing parameters until new parameters are set.

3.3.1 Read set parameters

Perform these steps to view the parameters set on the level transmitter.

Procedure

1. Press **Enter** to open the menu.
2. Press the up or down button to scroll through the set parameters.
3. Press **Enter** again to view the parameter value. The transmitter displays the value for 30 seconds then returns to the process value display.

3.3.2 Set parameters

Follow these steps to modify parameters values.

Procedure

1. Press **Enter** to open the menu.
2. Press the up or down buttons to navigate to a parameter.

3. Press **Enter** to select a parameter.
4. Press the up or down buttons for at least one second.
After one second the parameter value changes. Press and hold the button to change the value continuously.
5. Press **Enter**.
The level transmitter saves the new value.
6. Repeat steps 2 - 5 to modify other parameters.
After 30 seconds of inactivity, the menu returns to the process view display.

3.3.3 Change menu level

Perform these steps to move to the next menu level.

Procedure

1. Press **Enter** to get to the menu.
2. Press up or down until the menu displays **EF**.
3. Press **Enter**.
The display shows the next menu.

3.3.4 Lock or unlock the menu

Lock the menu to prevent unintentional changes to the parameters. By default, the menu is unlocked. When the menu is locked, it briefly displays **Loc** when you attempt to change a parameter value.

Prerequisites

The level transmitter must be in normal operating mode.

Procedure

1. Press and hold the up and down buttons simultaneously for 10 seconds.
The menu is locked and it displays **Loc**.
2. To unlock the menu, press and hold the up and down buttons for 10 seconds.
The menu is unlocked and it displays **uLoc**.

3.4 Setup the level transmitter

Procedures in this section provide instructions for configuring the settings and parameters of the level transmitter.

3.4.1 Enter probe length

Enter the length of the probe into the parameters to ensure accurate level measurements.

Procedure

1. Apply operating voltage.

- The display shows the initial display.
2. Select **LEnG** from the menu.
If the parameter does not contain a value, the display shows **nonE**.
 3. Press and hold up or down for at least one second. The display shows the detected probe length.
 4. If the detected probe length is incorrect, press up or down to change the probe length to the correct value.
 5. Press **Enter**.
The level transmitter proceeds to operating mode.

Notes

The level transmitter can automatically detect the length of the probe if:

- The tank is empty
- The level transmitter is mounted on a sufficiently large launching plate

For instructions on manually determining the length of the probe, see [Record probe length](#).

3.4.2 Perform a tank adjustment

Tank adjustment reduces the effect of interference and ensures a higher excess gain in difficult application conditions.

For more information on tank adjustments, see [Tank adjustment](#).

Prerequisites

The tank adjustment menu option **tREF** appears only if the set probe length is greater than or equal to 10.24 in (260 mm).

Procedure

1. Select **tREF** from the menu.
The display shows **nonE** or the value set by a previous tank adjustment.
2. Press and hold up or down for at least one second.
The display shows the distance value. The default value is 0.39 in (10 mm).
3. If necessary, correct the value using the up and down buttons.
4. Press **Enter**.
The display shows **donE**.
5. Press **Enter** again.
The level transmitter reboots and returns to operating mode.

3.4.3 Configure the display

Modify how the level transmitter displays information.

Procedure

1. Change the unit of measurement.

- a) Select **uni** from the menu.
 - b) Select **mm** for millimeters or **inch** for inches.
 - c) Press **Enter**.
2. Change the indicator.
 - a) Select **SELD** from the menu.
 - b) Set the type of indicator.
 - **L**: The level indicated in millimeters or inches.
 - **%**: The level indicated as a percentage. **ASP2** corresponds to 0% and **AEP2** corresponds to 100%.
 - **OFF**: The display is off by default. When a button is pressed, the display turns on for 30 seconds.

Change display between length and percentage

While the level transmitter is in operating mode, it displays the set unit of measurement. It can display the level measurement in a different unit of measurement during operation mode.

For more information on setting the default unit, see [Configure the display](#).

Procedure

1. Press up or down.
The display shows the level measurement in a different unit of measurement.
2. Press up or down again to return it to the default unit of measurement or wait for 30 seconds.

3.4.4 Set output signals

The procedures in this section provide instructions for modifying the output signals.

Set output function for OUT1

Follow these steps to set the function for the output 1 (OUT1).

Procedure

1. Select **ou1** from the menu.
2. Select a switching function.
 - **Hno**: Hysteresis function / normally open
 - **Hnc**: Hysteresis function / normally closed
 - **Fno**: Window function / normally open
 - **Fnc**: Window function / normally closed

Note

Use the **Hnc** switching function if the switching output is used as an overflow prevention. The principle of normally closed operation ensures that the level transmitter also detects wire breaks or cable breaks.

Set switching limits (hysteresis)

Use these steps to set the hysteresis limits for the switching output.

Procedure

1. Ensure that the function **Hno** or **Hnc** is set for **ou1** or **ou2**.
2. Select **SP1** or **SP2** then set the value at which the output is set.
3. Select **rP1** or **rP2** then set the value at which the output is reset.

Note

rPx is always smaller than **SPx**. The level transmitter accepts only values which are lower than the value for **SPx**. If **SPx** changes, **rPx** also changes provided that the lower end of the setting range is not reached.

Set switching limits (window)

Use these steps to set the limits for the window switching output.

Procedure

1. Ensure that the function **Fno** or **Fnc** is set for **ou1** or **ou2**.
2. Select **FH1** or **FH2** then set the upper limit of the acceptable range.
3. Select **FL1** or **FL2** then set the lower limit of the acceptable range.

Note

FLx is always lower than **FHx**. The level transmitter accepts only values which are lower than the value for **FHx**. If **FHx** changes, **FLx** also changes provided that the lower end of the setting range is not reached.

Set switch-on delay for switching outputs

Follow these steps to set the switch-on delay for switching outputs.

Procedure

1. Select **dS1** or **dS2** from the menu.
2. Set the value between 0.0 and 60 seconds.

Note

The switch-on delay reacts according to VDMA. According to VDMA, the switch-on delay always effects **SP** and the switch-off delay always effects **rP** irrespective of whether the level transmitter uses the normally open or normally closed function.

Set switch off delay for switching outputs

Follow these steps to set the switch-off delay for switching outputs.

Procedure

1. Select **dr1** or **dr2** from the menu.
2. Set the value between 0.0 and 60 seconds.

Note

The switch-on delay reacts according to VDMA. According to VDMA, the switch-on delay always effects SP and the switch-off delay always effects rP irrespective of whether the level transmitter uses the normally open or normally closed function.

Set output function for OUT2

Follow these steps to set the function for the output 2 (OUT2).

Procedure

1. Select **ou2** from the menu.
2. Set the switching function:
 - **I**: Current output 4-20 mA
 - **InEG**: Current output 20-4 mA
 - **Hno**: Hysteresis function/normally open
 - **Hnc**: Hysteresis function/normally closed
 - **Fno**: Window function/normally open
 - **Fnc**: Window function/normally closed

Note

If using the output to prevent overflow, set **ou2** = **Hnc** (NC function). The principle of normally closed operation ensures that wire break or cable break is also detected.

Scale analog signal

Follow these steps to modify the start and end points of the analog signal.

Procedure

1. Select **ASP2** and set the analog start point.
2. Select **AEP2** and set the analog end point.

Note

Setting these parameters with IO-Link is possible only if parameter **ou2** = **I** or **InEG**.

For more information, see [Analog signal](#).

Set output logic for switching outputs

Follow these steps to set the output logic for switching outputs.

Procedure

1. Select **P-n** from the menu.
2. Set **PnP** or **nPn**.

Set response of the outputs in case of fault

Follow these steps to modify how an output responds to faults.

Procedure

1. Select **FOU1** to modify the response for output 1 or **FOU2** to modify the response for output 2 from the menu.
2. Set a value:
 - **On**: Output switches ON in case of a fault.
The analog output switches to a value of greater than 21 mA in case of a fault.
 - **OFF**: Switching output switches OFF in case of a fault.
The analog output switches to a value of less than 3.6 mA in case of a fault.

Fault examples

- Defective hardware
- Signal quality too low

Note

The level transmitter does not consider overflow to be a fault.

Set damping for measured signal

Follow these steps to set the damping time for a measured signal.

Procedure

1. Select **dAP** from the menu.
2. Set damping in seconds.
The setting range is between 0.0 to 60.0 seconds.
For more information, see [Damping function](#).

Set delay time in case of a fault

Follow these steps to set the delay time after which the level transmitter identifies a fault.

Procedure

1. Select **dFo** from the menu.
2. Set a value between 0.0 and 10.0 seconds.

Note

The parameter **dFo** is effective only in the case of a fault. Mind the dynamics of your application. In case of fast level changes, change the value step by step. For more information, see [Fault states](#).

3.4.5 Reset all parameters to factory default settings

Follow these steps to reset all of the parameter values to the default factory settings.

Procedure

1. Select **rES** from the menu.
2. Press **Enter** until **rES** is aligned right.
3. Press and hold up or down until the display shows —.
4. Press **Enter**.
The level transmitter reboots and resets the parameter values to the default factory settings.

Note

The level transmitter is operational only after entering basic settings. For more information, see [Menu structure](#).

3.4.6 Change basic settings

Set these parameters after making any changes to the probe length or medium type.

Change the probe length

Modify the probe length parameter value after changing the length of the probe.

Procedure

1. Select **LEnG** from the menu.
2. Enter the probe length (L).
Note the set unit of measurement **uni**.
3. Press **Enter**.

Note

After changing the probe length, review or modify the values for the switching limits. For more information, see [Enter probe length](#).

Note

After changing the probe length, the unit deletes any existing tank adjustment. If necessary, perform a tank adjustment again. For more information, see [Perform a tank adjustment](#).

Set to another medium

If the medium in the tank has changed, modify the parameters for the medium to match the new medium.

Procedure

1. Select **MEdI** from the menu.
2. Set the medium type.
 - **HIGH**: For water and water-based media.
Operating mode is optimized for suppression of deposits on the probe.
 - **Mid**: For water-based media and media with a medium dielectric constant value (oil-in-water emulsions).
Operating mode optimized for the detection of media with increased foam build-up.
3. Press **Enter**.

Note

In case of doubt, perform an application test to ensure that the setting is best suited for the medium.

3.4.7 Simulation

Simulation mode allows you to perform tests on the level transmitter while it simulates levels and error scenarios.

Set simulation value

The simulation value determines what error scenario the simulation shows.

Procedure

1. Select **S.LvL** from the menu.
2. Set the simulation value:
 - **Numerical value**: level in millimeters or inches (depending on the basic setting)
 - **FULL**: full state
 - **SEnS**: weak measured signal
 - **Err**: electronic fault found
 - **EPTY**: empty state
3. Press **Enter**.

Set simulation duration

The simulation duration parameter sets the length in time of the simulation.

Procedure

1. Select **S.Tim** from the menu.
2. Set time span for simulation.
Setting range: 1, 2, 3, 4, 5, 10, 15, 20, 30, 45, 60 minutes
Factory setting: three minutes
3. Press **Enter**.

Switch simulation on or off

Switching the simulation on starts the simulation and switching it off cancels the simulation.

Procedure

1. Select **S.On** from the menu.
2. Select **On** or **OFF**.
3. Press **Enter**.

Note

The simulation is active until **Enter** is pressed again or the time set via **S.Tim** elapses. During the simulation, the level transmitter displays **SIM** every three seconds. After the simulation, the level transmitter goes again to the parameter **S.On** and internally the level transmitter goes again to the operating mode (and the process value transmission).

After another 30 seconds the display goes again to the process value display.

Note

If using IO-Link to start and configure a simulation, it can be canceled only using IO-Link. The level transmitter displays **C.Loc** if the simulation is attempted to be canceled with the function buttons.

3.5 Using the transmitter

The procedures in this section provide instructions for operating the level transmitter.

3.5.1 Operation with a single probe

Using the level transmitter with a single probe is suited for the detection of aqueous media, especially heavily soiled aqueous media.

Note

The level transmitter is intended only for operation with a single probe. A coaxial probe is not available for this unit.

To correctly transfer the microwave pulse to the tank with optimum transmission power, the level transmitter needs a sufficiently large metal launching surface or launching plate.

For installation in closed metal tanks or metal bypass pipes, the tank lid or upper pipe section serves as a launching surface. Use a sufficiently large fixing plate, metal plate or something similar when installing in open metal tanks, plastic tanks, or metal tanks with plastic lids. For more information, see [Installing in an open tank](#) or [Installing in a plastic tank](#).

3.5.2 Operation with a bypass or still pipe

Use a bypass or a still pipe in applications like heavy foam build-up.

For more information about heavy foam build-up and turbulence, see [Heavy foam build-up and turbulence](#).

For more information about the minimum internal pipe diameter, see [Installation in pipes](#).

For general installation instructions, see [Installation](#).

3.5.3 Function check

After turning on the level transmitter, it is in operating mode. It measures and evaluates level and generates output signals according to the set parameters.

Check that the level transmitter is operating correctly before using it in a production environment.

3.5.4 Operation indication

These indicators show how the level transmitter is operating.

Indicator	Definition
---- continuous	Initialization phase after power on
	Initially the level transmitter is not operational. Configure basic settings to enable the level transmitter (see Change basic settings).
----	Level below the active zone
Numerical value + LED 1	Current level in millimeters
Numerical value + LED 2	Current level in inches
Numerical value + LED 3	Current level in percent of the scaled measuring range
LED 7 / LED 8	Switching status OUT2/OUT1
FULL + numerical value alternately	Level has reached or exceeded the maximum measuring range (= overflow warning).
SIM + XXX	Simulation active. XXX = state to be simulated (See Simulation)
S.On	Simulation stopped (See Simulation)

Indicator	Definition
Loc	The level transmitter is locked using the function buttons. Setting parameter values is not possible without unlocking the level transmitter. To unlock the level transmitter, press and hold up and down for 10 seconds.
uLoc	The level transmitter is unlocked or the parameter setting is possible again.
C.Loc	The level transmitter is temporarily locked. Parameter setting via IO-Link is active.
S.Loc	The level transmitter permanently locked via IO-Link. Unlocking is possible only via IO-Link.

3.6 Setting parameters with IO-Link

During setup, send valid basic settings to the device even if the default settings correspond to the connected device. Enter the basic settings correctly according to the attached probe and the medium to be detected.

3.6.1 Set parameters using IO-Link

Use IO-Link software to set parameter settings on the level transmitter using a computer.

Procedure

1. Enter probe length (**LEnG**). Example: **LEnG** = 1000 mm.
2. Scale analog output (**ASP2** and **AEP2**; **AEP2** must at least be 20 % greater than **ASP2**). Example: **AEP2** = 970 mm.
3. Alternatively: Set parameter **ou2** to **H..** or **F...**
4. Select the medium (**MEdi**). Example: **MEdi** = **MId**.
 - **HIGH** = For water and water-based media. Operating mode is optimized for suppression of deposits on the probe.
 - **MId** = For water-based media and media with a mean dielectric constant value. Operating mode is optimized for media with increased foam build-up.
5. Transfer the transmitter data to the unit.
6. Carry out tank adjustment depending on the installation (**tREF** or button "TEACH_TANK_REF").
To change the adjustment distance (**RefDist**), send this individual parameter to the transmitter first. Then, perform a tank adjustment. Select the adjustment distance according to, for example, the height of connection pieces or the position of structures in the tank. Within the adjustment distance, starting from the process connection, interfering reflections are compensated. Example: **RefDist** = 50 mm.
7. Modify any other parameter values.

Note

Only if data storage is required in an IO-Link application:

IO-Link does not save tank adjustment information. After the level transmitter fails, perform another tank adjustment. The level transmitter reverts to the cyclical process data transmission after performing a tank adjustment successfully.
After a factory reset, the device reboots and the factory settings are restored.

3.6.2 Unit locking and data storage

The IO-Link master saves all parameters of the connected transmitter (except tank adjustment) if configured in the master (data storage). When a transmitter is replaced by a transmitter of the same type, the parameters of the old transmitter are automatically written to the new transmitter if configured in the master and if the transmitter allows this.

For safety reasons, the level transmitter can refuse the parameter download.

Factory default setting: Open

Data storage

- Open: the transmitter allows parameter download from the master
- Locked: the transmitter refuses parameter download from the master

4 Troubleshooting and maintenance

The topics in this section provide information on identifying and resolving issues and maintaining the level transmitter.

4.1 Error indicators

This table describes error scenarios for the level transmitter and possible solutions.

Indicator	Possible cause	Recommended fix
Err	Fault in the electronics.	Replace the unit.
nPrb	Probe detached from the unit; possibly incorrect setting of the probe length.	Check whether the probe is still attached to the unit. Check the parameter LEnG .
SEnS	Measurement disturbed by heavy foam build-up or turbulence.	<ul style="list-style-type: none"> Install the unit in a still pipe or bypass (Installation) Set or increment dFo (Set delay time in case of a fault)
	Measurement disturbed by separation layers (e.g. oil layer on water).	Remove the oil layer by suction, stir the medium, verify the composition.
	Probe or process connection soiled.	Clean the probe and the process connection.
	Installation conditions not adhered to.	<ul style="list-style-type: none"> Observe the notes in Installation. Repeat or perform a tank adjustment. (Tank adjustment)
	Probe length or sensitivity (setting to the medium) incorrect.	Correct settings then perform a tank adjustment (Tank adjustment).
SCx + LED 7 SCx + LED 8	Flashing: short circuit in switching output OUT1 or OUT2.	Remove the short circuit.
SC + LED 7 + LED 8	Flashing: short circuit in both switching outputs	Remove the short circuit.
PARA	Faulty data set	Restore factory default settings (See Reset all parameters to factory default settings)

4.2 Output response in different operating states

These tables provide information on the response of outputs for different operating states.

Operating state	OUT1	OUT2 ⁽¹⁾
Initialization	OFF	OFF

Operating state	OUT1	OUT2 ⁽¹⁾
Normal operation	According to the level and ou1 setting	According to the level 4 - 20 mA
Fault	OFF with FOU1 = OFF; ON with FOU1 = On	< 3.6 mA with FOU2 = OFF > 21 mA with FOU2 = On

(1) If the analog function ou2 = I has been selected. If the switching function has been selected: see column OUT1.

Additions to the analog output		
Full signal	With ou2 = I:	20 - 20.5 mA
	With ou2 = InEG:	4 - 3.8 mA
Empty signal	With ou2 = I:	4 - 3.8 mA
	With ou2 = InEG:	20 - 20.5 mA

4.3 Maintenance

This section includes notes on maintaining the level transmitter.

- Keep the process connection free of deposits and foreign bodies.
- In case of heavy soiling: clean the process connection and probe. For cleaning purposes, the level transmitter can be removed from the adapter and the probe can be screwed off the unit.

⚠ CAUTION

Before installing or removing the unit:

- Ensure no pressure is applied to the system and there is no medium in the tank that could leak.
- Note the potential dangers related to extreme machine and medium temperatures.

- Use only tools suitable for plastic surfaces for wetted surfaces.
- Ensure gasketed connections (probe or process connection adapter) are not soiled or damaged. Check sealing rings for damage.
- Replace any damaged parts.
- After changing the medium, it may be necessary to change the settings of the level transmitter. (See [Set to another medium](#))
- IO-Link does not save tank adjustment information. After replacing the transmitter, perform another tank adjustment. (See [Perform a tank adjustment](#))
- It is not possible to repair the level transmitter.
- After use, dispose of the unit in an environmentally friendly way in accordance with the applicable national regulations.

- In case of returns, ensure that the unit is free from soiling, especially dangerous and toxic substances.

4.3.1 Cleaning and maintenance in 3-A[®] applications

Follow these steps when cleaning the level transmitter in a 3-A compliant environment. Regularly perform clean out of place (COP) cleaning on the level transmitter to conform to 3-A standards.

Prerequisites

Before installing the level transmitter:

- Ensure that no pressure is applied to the system and that there is no media in the tank that could leak.
- Note the potential dangers related to extreme machine and medium temperatures.

Procedure

1. Remove the probe from the unit.
2. Remove O-ring from the transmitter.
3. Remove O-ring from the groove and clean it.
4. Check O-ring and groove.
5. Reassemble the level transmitter.

4.3.2 Transport

When transporting the level transmitter, follow these guidelines to avoid damage.

- Use only appropriate packaging.
- If installed in a tank or pipe, protect the tank or pipe and the level transmitter against shock and vibration. Protect the probe against deflections and vibrations. If necessary, fix at several points to prevent movement of unstable areas.

5 Setting ranges

These tables show the setting ranges for the level transmitter parameters.

LEnG	inch	mm
Setting range	6.0 - 78.8	150 - 2000
Step increment	0.2	5

The setting ranges for the switching limits (SPx, rPx, FHx, FLx) depend on the probe length (L). In general the following applies:

Parameters	inch		mm	
	min	max	min	max
SPx/FHx	0.6	L - 1.2	15	L - 30
rPx/FLx	0.4	L - 1.4	10	L - 35
Step increment	0.05		1	

rPx/FLx is always smaller than SPx / FHx. If SPx / FHx is shifted, rPx / FLx also shifts provided that the lower end of the setting range is not reached. Always set SPx / FHx first, then rPx / FLx.

The setting ranges for analog start point ASP2 and analog end point AEP2 depend on the probe length (L). In general the following applies:

Parameters	inch		mm	
	min	max	min	max
ASP2	0	N/A	0	N/A
AEP2	N/A	L - 1.2	N/A	L - 30
Step increment	0.05		1	

Minimum distance between ASP2 and AEP2 is 20 percent of the active zone.

6 Product certifications

6.1 European directive information

The most recent revision of the EC Declaration of Conformity can be found at Emerson.com/Rosemount.

6.2 Ordinary location information

As standard, this product has been examined and tested to determine that the design meets the basic electrical, mechanical, and fire protection requirements by a nationally recognized test laboratory (NRTL) as accredited by the Federal Occupational Safety and Health Administration (OSHA).

6.3 3-A[®] certification

This product is authorized to display the 3-A symbol. Ensure gaskets and process connection accessories selected for installation meet both the application and 3-A requirements. A certificate of compliance is available at Emerson.com/Rosemount.

6.4 Other industry certifications

All Rosemount 326L transmitter surfaces and materials which come into contact with process medium comply with the following regulations:

7 Factory settings

Use this worksheet to record modified parameter settings.

Parameter	Factory default setting	User-defined setting
tREF	nonE	
SP1	50% VMR ⁽¹⁾	
rP1	0.2 in (5 mm) below SP1	
ASP2	0 % VMR ⁽¹⁾	
AEP2	100 % VMR ⁽¹⁾	
dS1	0.0	
dr1	0.0	
ou1	Hno	
ou2	I	
uni	inch	
P-n	PnP	
FOU1	OFF	
FOU2	OFF	
SELd	L	
dAP	0.0	
dFo	3.0	
LEnG	nonE	
MEdI	MID	
S.LVL	50 % LEnG	
S.Tim	3	
S.On	OFF	

(1) VMR = final value of the measuring range = LEnG value minus 1.18 in (30 mm). When the LEnG value is entered, the unit calculates the basic setting.



00825-0100-4326
Rev. 01
2019

Global Headquarters

Emerson Automation Solutions
6021 Innovation Blvd
Shakopee, MN 55379, USA

+1 800 999 9307 or +1 952 906 8888

+1 952 949 7001

RFQ.RMD-RCC@Emerson.com

North America Regional Office

Emerson Automation Solutions
8200 Market Blvd.
Chanhassen, MN 55317, USA

+1 800 999 9307 or +1 952 906 8888

+1 952 949 7001

RMT-NA.RCCRF@Emerson.com

 [Linkedin.com/company/Emerson-Automation-Solutions](https://www.linkedin.com/company/Emerson-Automation-Solutions)

 [Twitter.com/Rosemount_News](https://twitter.com/Rosemount_News)

 [Facebook.com/Rosemount](https://www.facebook.com/Rosemount)

 [Youtube.com/user/RosemountMeasurement](https://www.youtube.com/user/RosemountMeasurement)

©2019 Emerson. All rights reserved.

Emerson Terms and Conditions of Sale are available upon request. The Emerson logo is a trademark and service mark of Emerson Electric Co. Rosemount is mark of one of the Emerson family of companies. All other marks are the property of their respective owners.

ROSEMOUNT™

