

# Rosemount™ 3051 Pressure Transmitter and Rosemount 3051CF Series Flowmeter with PROFIBUS® PA Protocol



**NOTICE**

This installation guide provides basic guidelines for Rosemount 3051 Transmitters. It does not provide instructions for configuration, diagnostics, maintenance, service, troubleshooting, Explosion-Proof, Flame-Proof, or intrinsically safe (I.S.) installations. Refer to the Rosemount 3051 [Reference Manual](#) for more instruction. This manual is also available electronically on [EmersonProcess.com/Rosemount](http://EmersonProcess.com/Rosemount).

**⚠ WARNING**

**Explosions could result in death or serious injury.**

Installation of this transmitter in an explosive environment must be in accordance with the appropriate local, national, and international standards, codes, and practices. Review the approvals section of the Rosemount 3051 [Reference Manual](#) for any restrictions associated with a safe installation.

- In an Explosion-Proof/Flameproof installation, do not remove the transmitter covers when power is applied to the unit.

**Process leaks may cause harm or result in death.**

- To avoid process leaks, only use the O-ring designed to seal with the corresponding flange adapter.

**Electrical shock can result in death or serious injury.**

- Avoid contact with the leads and the terminals. High voltage that may be present on leads can cause electrical shock.

**Conduit/cable entries**

- Unless marked, the conduit/cable entries in the transmitter housing use a 1/2–14 NPT thread form. Only use plugs, adapters, glands or conduit with a compatible thread form when closing these entries.

**Contents**

Mount the transmitter .....	3	Basic configuration .....	10
Consider housing rotation .....	7	Trim the transmitter .....	13
Set jumpers and switches .....	7	Product Certifications.....	14
Connect wiring and power up .....	8		

# 1.0 Mount the transmitter

## 1.1 Liquid applications

1. Place taps to the side of the line.
2. Mount beside or below the taps.
3. Mount the transmitter so the drain/vent valves are oriented upward.

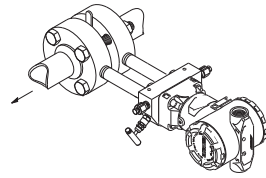

## 1.2 Gas applications

1. Place taps in the top or side of the line.
2. Mount beside or above the taps.

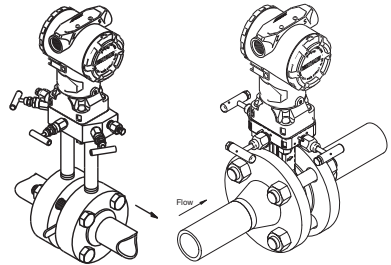

## 1.3 Steam applications

1. Place taps to the side of the line.
2. Mount beside or below the taps.
3. Fill impulse lines with water.

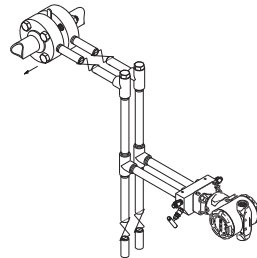

# 1.4 Mounting options

Panel mount<sup>(1)</sup>

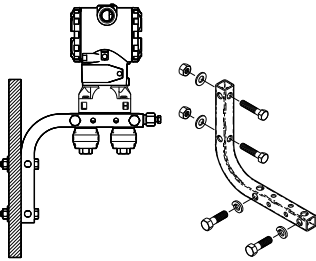

Pipe mount

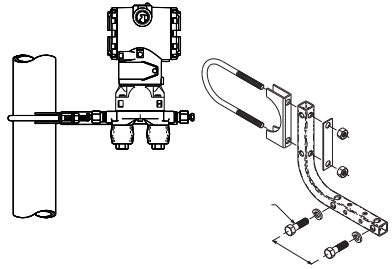

Coplanar flange

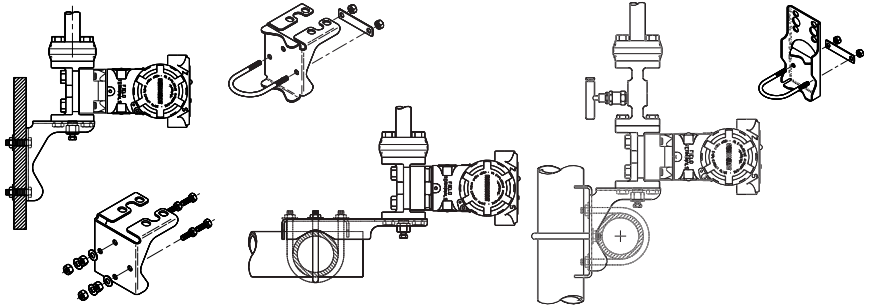

Traditional flange

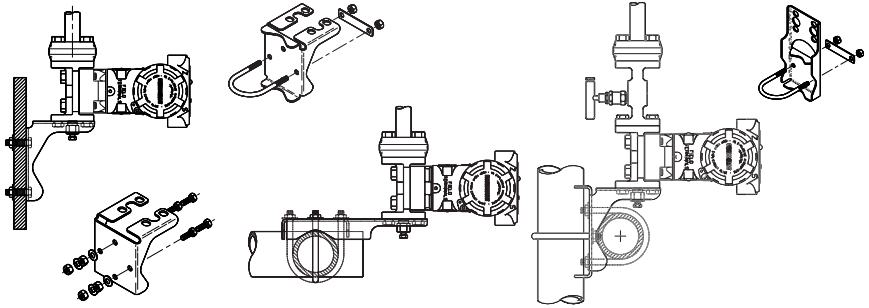

Rosemount 3051T

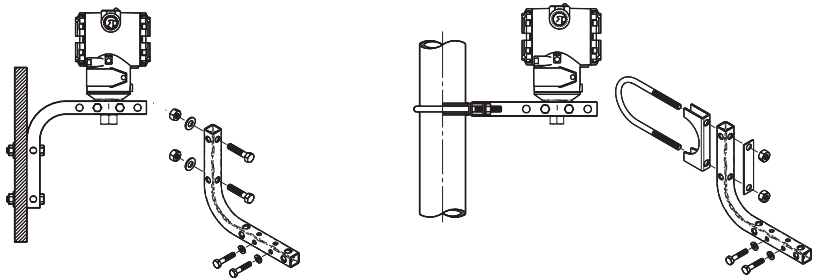

1. Panel bolts are customer supplied.

## 1.5 Bolting considerations

If the transmitter installation requires assembly of the process flanges, manifolds, or flange adapters, follow these assembly guidelines to ensure a tight seal for optimal performance characteristics of the transmitters. Use only bolts supplied with the transmitter or sold by Emerson™ Process Management as spare parts. [Figure 1](#) illustrates common transmitter assemblies with the bolt length required for proper transmitter assembly.

**Figure 1. Common Transmitter Assemblies**

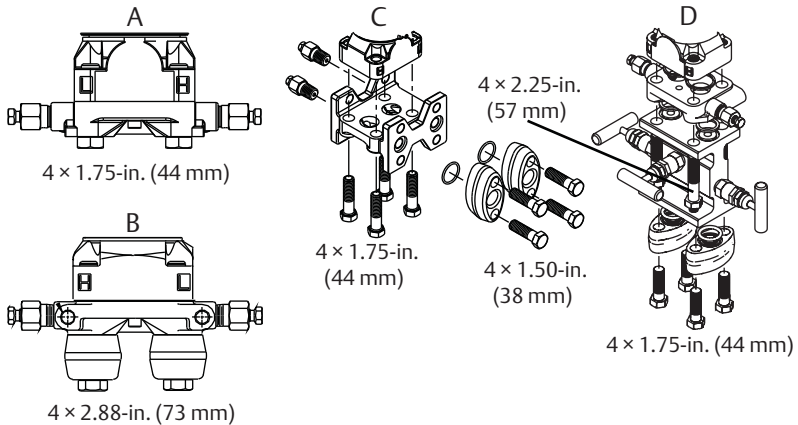

- A. Transmitter with coplanar flange
- B. Transmitter with coplanar flange and optional flange adapters
- C. Transmitter with traditional flange and optional flange adapters
- D. Transmitter with coplanar flange and optional manifold and flange adapters

Bolts are typically carbon steel or stainless steel. Confirm the material by viewing the markings on the head of the bolt and referencing [Table 1](#). If bolt material is not shown in [Table 1](#), contact the local Emerson Process Management representative for more information.

Use the following bolt installation procedure:

1. Carbon steel bolts do not require lubrication and the stainless steel bolts are coated with a lubricant to ease installation. However, no additional lubricant should be applied when installing either type of bolt.
2. Finger-tighten the bolts.
3. Torque the bolts to the initial torque value using a crossing pattern. See [Table 1](#) for initial torque value.
4. Torque the bolts to the final torque value using the same crossing pattern. See [Table 1](#) for final torque value.
5. Verify the flange bolts are protruding through the isolator plate before applying pressure.

**Table 1. Torque Values for the Flange and Flange Adapter Bolts**

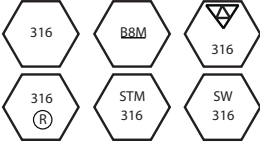
Bolt material	Head markings	Initial torque	Final torque
Carbon Steel (CS)		300 in-lb	650 in-lb
Stainless Steel (SST)		150 in-lb	300 in-lb

## 1.6 O-rings with flange adapters

### **⚠ WARNING**

Failure to install proper flange adapter O-rings may cause process leaks, which can result in death or serious injury. The two flange adapters are distinguished by unique O-ring grooves. Only use the O-ring that is designed for its specific flange adapter, as shown below:

Rosemount 3051S/3051/2051

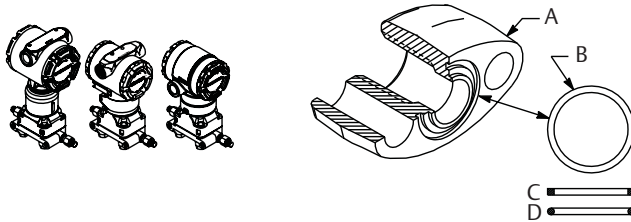

- A. Flange adapter
- B. O-ring
- C. PTFE based (profile is square)
- D. Elastomer (profile is round)

**⚠** Whenever the flanges or adapters are removed, visually inspect the O-rings. Replace them if there are any signs of damage, such as nicks or cuts. If you replace the O-rings, re-torque the flange bolts and alignment screws after installation to compensate for seating of the PTFE O-ring.

## 1.7 Environmental seal for housing

Thread sealing (PTFE) tape or paste on male threads of conduit is required to provide a water/dust tight conduit seal and meets requirements of NEMA Type 4X, IP66, and IP68. Consult factory if other Ingress Protection ratings are required.

For M20 threads, install conduit plugs to full thread engagement or until mechanical resistance is met.

## 1.8 In-line gage transmitter orientation

The low side pressure port (atmospheric reference) on the in-line gage

transmitter is located in the neck of the transmitter, behind the housing. The vent path is 360° around the transmitter between the housing and sensor. (See Figure 2.)

Keep the vent path free of any obstruction, including but not limited to paint, dust, and lubrication by mounting the transmitter so that the process can drain away.

**Figure 2. In-line Gage Low Side Pressure Port**

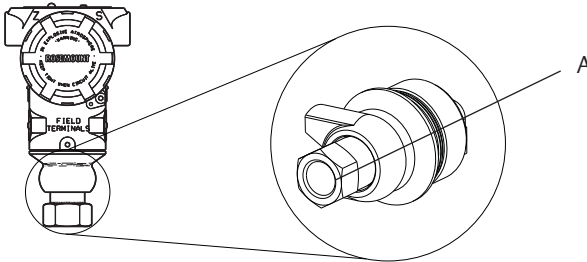

A. Low side pressure port (atmospheric reference)

## 2.0 Consider housing rotation

To improve field access to wiring or to better view the optional LCD display:

1. Loosen the housing rotation set screw.
2. First, rotate the housing clockwise to the desired location. If the desired location cannot be achieved due to thread limit, rotate the housing counter clockwise to the desired location (up to 360° from thread limit).
3. Retighten the housing rotation set screw.

**Figure 3. Housing Rotation Set Screw**

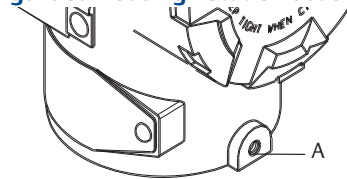

A. Housing rotation set screw (<sup>5</sup>/<sub>64</sub>-in.)

## 3.0 Set jumpers and switches

### 3.1 Security

After the transmitter is configured, you may want to protect the configuration data from unwarranted changes. Each transmitter is equipped with a security jumper that can be positioned “ON” to prevent the accidental or deliberate change of configuration data. The jumper is labeled “Security”. The security jumper also prevents changes made using the Local Operator Interface.

## 3.2 Simulate

The simulate jumper is used in conjunction with the analog input (AI) block. This jumper is used to simulate the pressure measurement and is used as a lock-out feature for the AI block. To enable the simulate feature, the jumper must be moved to the "ON" position after power is applied. This feature prevents the transmitter from being accidentally left in simulate mode.

**Figure 4. Transmitter Jumper Locations**

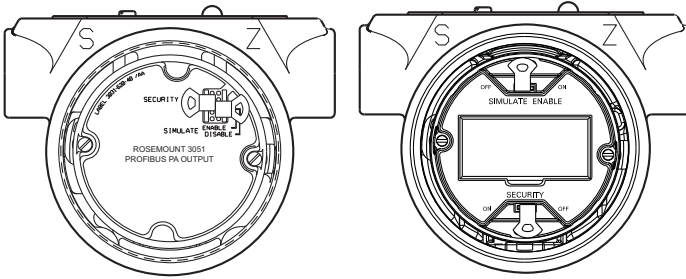

## 4.0 Connect wiring and power up

Use the following steps to wire the transmitter:

1. Remove the housing cover on the field terminals side.
2. Connect the power leads to the terminals indicated on the terminal block label.
  - Power terminals are polarity insensitive - connect positive or negative to either terminal
3. Ensure full contact with Terminal Block screw and washer. When using a direct wiring method, wrap wire clockwise to ensure it is in place when tightening the terminal block screw.

### Note

The use of a pin or a ferrule wire terminal is not recommended as the connection may be more susceptible to loosening over time or under vibration.

4. Ensure proper grounding. It is important that the instrument cable shield:
  - Be trimmed close and insulated from touching the transmitter housing
  - Be connected to the next shield if cable is routed through a junction box
  - Be connected to a good earth ground at the power supply end
5. Plug and seal unused conduit connections.
6. If applicable, install wiring with a drip loop. Arrange the drip loop so the bottom is lower than the conduit connections and the transmitter housing.
7. Replace the housing cover.



**Figure 5. Terminals**

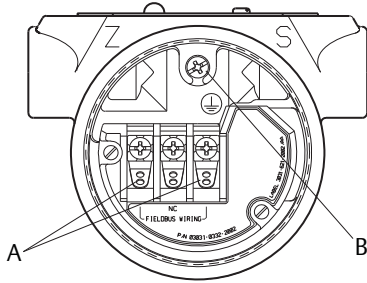

A. Power terminals

B. Ground terminal

Note: "NC" is a No Connect terminal (do not use)

**Figure 6. Wiring**

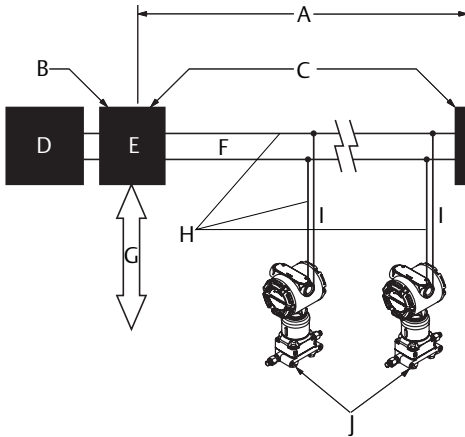

- A. 6234 ft (1900 m) max  
(depending upon cable characteristics)
- B. Integrated power conditioner and filter
- C. Terminators
- D. Power supply
- E. DP/PA coupler/link

- F. Trunk
- G. DP network
- H. Signal wiring
- I. Spur
- J. PROFIBUS PA device

## 4.1 Signal wiring grounding

Do not run signal wiring in conduit or open trays with power wiring, or near heavy electrical equipment. Grounding terminations are provided on the outside of the electronics housing and inside the terminal compartment. These grounds are used when transient protect terminal blocks are installed or to fulfill local regulations. See [Step 2](#) below for more information on how the cable shield should be grounded.

1. Remove the Field Terminals housing cover.

2. Connect the wiring pair and ground as indicated in [Figure 7](#). The cable shield should:
  - Be trimmed close and insulated from touching the transmitter housing.
  - Continuously connect to the termination point.
  - Be connected to a good earth ground at the power supply end.

**Figure 7. Wiring**

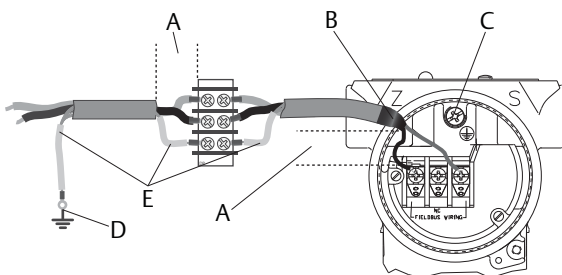

- A. Minimize distance  
 B. Trim shield and insulate  
 C. Ground for transient protection  
 D. Connect shield back to the power supply ground  
 E. Insulate shield

3. Replace the housing cover. It is recommended the cover be tightened until there is no gap between the cover and the housing.
4. Plug and seal unused conduit connections.

## Power supply

The dc power supply should provide power with less than two percent ripple. The transmitter requires between 9 and 32 Vdc at the terminals to operate and provide complete functionality

## Power conditioner

The DP/PA coupler/link often includes an integrated power conditioner.

## Grounding

Transmitters are electrically isolated to 500 Vac rms. Signal wiring can not be grounded.

## Shield wire ground

Grounding techniques for shield wire usually require a single grounding point for shield wire to avoid creating a ground loop. The ground point is typically at the power supply.

# 5.0 Basic configuration

## 5.1 Configuration tasks

The transmitter can be configured via either the local operator interface (LOI) – option code M4, or via a Class 2 Master (DD or DTM™ based). The two basic

---

configuration tasks for the PROFIBUS PA Pressure transmitter are:

1. Assign address.
2. Configure engineering units (scaling).

---

**Note**

Rosemount 3051 Profibus Profile 3.02 devices are set to identification number adaptation mode when shipped from the factory. This mode allows the transmitter to communicate with any Profibus control host with either the generic Profile GSD (9700) or Rosemount 3051 specific GSD (4444) loaded on the host; therefore, it is not required to change the transmitter identification number at startup.

---

## 5.2 Assign address

The Rosemount 3051 Pressure Transmitter is shipped with a temporary address of 126. This must be changed to a unique value between 0 and 125 in order to establish communication with the host. Usually, addresses 0–2 are reserved for masters or couplers, therefore transmitter addresses between 3 and 125 are recommended.

Address can be set via either:

- LOI – see [Table 2](#) and [Figure 8](#)
- Class 2 Master – see Class 2 Master manual for setting address

## 5.3 Configure engineering units

Unless otherwise requested, the Rosemount 3051 Pressure Transmitter ships with the following settings:

- Measurement mode: Pressure
- Engineering units: inches H<sub>2</sub>O
- Scaling: None

Engineering units should be confirmed or configured before installation. Units can be configured for Pressure, Flow or Level measurement.

Measurement type, Units, Scaling, and Low Flow Cutoff (when applicable) can be set via either:

- LOI – see [Table 2](#) and [Figure 8](#)
- Class 2 master – see [Table 3](#) for parameter configuration

## 5.4 Configuration tools

### Local operator interface (LOI)

When ordered, the LOI can be used for commissioning the device. To activate the LOI, push either configuration button located under the top tag of the transmitter. See [Table 2](#) and [Figure 8](#) for operation and menu information. The security jumper prevents changes made using the LOI.



---

**Note**

Buttons must be fully engaged ≈ 0.5 in. (10mm) of travel.

---

**Table 2. LOI Button Operation**

Button	Action	Navigation	Character Entry	Save?
	Scroll	Moves down menu categories	Changes character value <sup>(1)</sup>	Changes between Save and Cancel
	Enter	Selects menu category	Enters character and advances	Saves

1. Characters blink when they can be changed.

**Figure 8. LOI Menu**

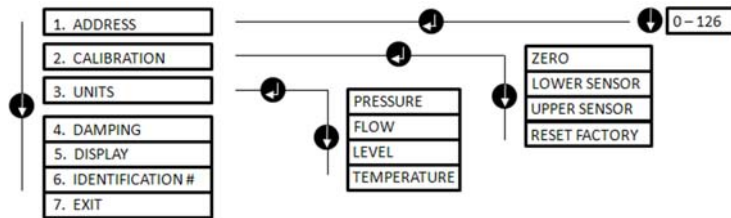

## 5.5 Class 2 Master

The Rosemount 3051 Profibus DD and DTM files are available at [EmersonProcess.com/Rosemount](http://EmersonProcess.com/Rosemount) or by contacting your local salesperson. See [Table 3](#) for steps to configure the transmitter for Pressure measurement. See the Rosemount 3051 [Reference Manual](#) for Flow or Level configuration instructions.

**Table 3. Pressure Configuration via Class 2 Master**

Steps	Actions
Set blocks to Out of Service	Put Transducer Block into Out of Service mode
	Put Analog Input Block into Out of Service mode
Select Measurement Type	Set Primary Value type to Pressure
Select Units	Set Engineering Units
	- Primary and secondary units must match
Enter Scaling	Set Scale In in Transducer Block to 0 - 100
	Set Scale Out in Transducer Block to 0 - 100
	Set PV Scale in Analog Input Block to 0 - 100
	Set Out Scale in Analog Input Block to 0 - 100
	Set Linearization in Analog Input Block to No Linearization
Set blocks to Auto	Put Transducer Block into Auto mode
	Put Analog Input Block into Auto mode

## Host integration

### Control host (Class 1)

The Rosemount 3051 device utilizes condensed status as recommended by the Profile 3.02 specification and NE 107. See manual for condensed status bit assignment information.

The appropriate GSD file must be loaded on the control host - Rosemount 3051 specific ([rmt4444.gsd](#)) or Profile 3.02 Generic ([pa139700.gsd](#)). These files can be found on [EmersonProcess.com/Rosemount](#) or [Profibus.com](#).

### Configuration host (Class 2)

The appropriate DD or DTM file must be installed in the configuration host. These files can be found at [EmersonProcess.com/Rosemount](#).

## 6.0 Trim the transmitter

Devices are calibrated by the factory. Once installed, it is recommended to perform a zero trim on the sensor to eliminate error due to mounting position or static pressure effects.

This can be done by performing a zero trim via:

- LOI – see [Table 2](#) and [Figure 8](#)
- Class 2 master – see [Zero trim via Class 2 Master](#) for parameter settings

### 6.1 Zero trim via Class 2 Master

1. Place the transducer block into **Out of Service (OOS)** mode.
2. Apply zero pressure to device and allow to stabilize.
3. Go to *Device Basic Setup > Calibration* and set the Lower Calibration Point to **0.0**.
4. Place the transducer block to **AUTO** mode.

## 7.0 Product Certifications

Rev 1.4

### 7.1 European Directive Information

A copy of the EC Declaration of Conformity can be found at the end of the Quick Start Guide. The most recent revision of the EC Declaration of Conformity can be found at [EmersonProcess.com/Rosemount](http://EmersonProcess.com/Rosemount).

### 7.2 Ordinary Location Certification

As standard, the transmitter has been examined and tested to determine that the design meets the basic electrical, mechanical, and fire protection requirements by a nationally recognized test laboratory (NRTL) as accredited by the Federal Occupational Safety and Health Administration (OSHA).

### 7.3 North America

#### **E5** USA Explosionproof (XP) and Dust-Ignitionproof (DIP)

Certificate: 0T2H0.AE

Standards: FM Class 3600 – 2011, FM Class 3615 – 2006, FM Class 3810 – 2005, ANSI/NEMA 250 – 2003

Markings: XP CL I, DIV 1, GP B, C, D; DIP CL II, DIV 1, GP E, F, G; CL III; T5(-50 °C ≤ T<sub>a</sub> ≤ +85 °C); Factory Sealed; Type 4X

#### **I5** USA Intrinsic Safety (IS) and Nonincendive (NI)

Certificate: 1Q4A4.AX

Standards: FM Class 3600 – 2011, FM Class 3610 – 2010, FM Class 3611 – 2004, FM Class 3810 – 2005

Markings: IS CL I, DIV 1, GP A, B, C, D; CL II, DIV 1, GP E, F, G; Class III; DIV 1 when connected per Rosemount drawing 03031-1019; NI CL 1, DIV 2, GP A, B, C, D; T4(-50 °C ≤ T<sub>a</sub> ≤ +70 °C) [HART], T5(-50 °C ≤ T<sub>a</sub> ≤ +40 °C) [HART]; T4(-50 °C ≤ T<sub>a</sub> ≤ +60 °C) [Fieldbus/PROFIBUS]; Type 4x

#### **Special Conditions for Safe Use (X):**

1. The Rosemount 3051 Transmitter housing contains aluminum and is considered a potential risk of ignition by impact or friction. Care must be taken into account during installation and use to prevent impact and friction.
2. The Rosemount 3051 Transmitter with the transient terminal block (Option code T1) will not pass the 500Vrms dielectric strength test and this must be taken into account during installation.

#### **IE** USA FISCO

Certificate: 1Q4A4.AX

Standards: FM Class 3600 - 2011, FM Class 3610 - 2010, FM Class 3611 - 2004, FM Class 3810 - 2005



Markings: IS CL I, DIV 1, GP A, B, C, D when connected per Rosemount drawing 03031-1019 (-50 °C ≤ T<sub>a</sub> ≤ +60 °C); Type 4x

#### **Special Conditions for Safe Use (X):**

1. The Rosemount 3051 Transmitter housing contains aluminum and is considered a potential risk of ignition by impact or friction. Care must be taken into account during installation and use to prevent impact and friction.
2. The Rosemount 3051 Transmitter with the transient terminal block (Option code T1) will not pass the 500Vrms dielectric strength test and this must be taken into account during installation.

- C6** Canada Explosionproof, Dust-Ignitionproof, Intrinsic Safety and Nonincendive Certificate: 1053834  
 Standards: ANSI/ISA 12.27.01-2003, CSA Std. C22.2 No. 30 -M1986, CSA Std. C22.2 No.142-M1987, CSA Std. C22.2. No.157-92, CSA Std. C22.2 No. 213 - M1987  
 Markings: Explosionproof for Class I, Division 1, Groups B, C and D; Suitable for Class I, Zone 1, Group IIB+H2, T5; Dust-Ignitionproof Class II, Division 1, Groups E, F, G; Class III Division 1; Intrinsically Safe Class I, Division 1 Groups A, B, C, D when connected in accordance with Rosemount drawing 03031-1024, Temperature Code T3C; Suitable for Class I, Zone 0; Class I Division 2 Groups A, B, C and D, T5; Suitable for Class I Zone 2, Group IIC; Type 4X; Factory Sealed; Single Seal (See drawing 03031-1053)
- E6** Canada Explosionproof, Dust-Ignitionproof and Division 2 Certificate: 1053834  
 Standards: ANSI/ISA 12.27.01-2003, CSA Std. C22.2 No. 30 -M1986, CSA Std. C22.2 No.142-M1987, CSA Std. C22.2 No. 213 - M1987  
 Markings: Explosionproof Class I, Division 1, Groups B, C and D; Suitable for Class I, Zone 1, Group IIB+H2, T5; Dust-Ignitionproof for Class II and Class III, Division 1, Groups E, F and G; Class I, Division 2, Groups A, B, C and D; Suitable for Class I Zone 2, Group IIC; Type 4X; Factory Sealed; Single Seal (See drawing 03031-1053)

## 7.4 Europe

- E8** ATEX Flameproof and Dust Certificate: KEMA00ATEX2013X; Baseefa11ATEX0275X  
 Standards: EN60079-0:2012 + A11:2013, EN60079-1:2007, EN60079-26:2007, EN60079-31:2009  
 Markings:  II 1/2 G Ex d IIC T6/T5 Ga/Gb, T6(-50 °C ≤ T<sub>a</sub> ≤ +65 °C), T5(-50 °C ≤ T<sub>a</sub> ≤ +80 °C)  
 II 1 D Ex ta IIIC T95 °C T<sub>500</sub> 105 °C Da (-20°C ≤ T<sub>a</sub> ≤ +85°C)

**Table 4. Process Temperature**

Temperature class	Process temperature
T6	-50 °C to +65 °C
T5	-50 °C to +80 °C



**Special Conditions for Safe Use (X):**

1. This device contains a thin wall diaphragm. Installation, maintenance and use shall take into account the environmental conditions to which the diaphragm will be subjected. The manufacturer’s instructions for installation and maintenance shall be followed in detail to assure safety during its expected lifetime.
2. For information on the dimensions of the flameproof joints the manufacturer shall be contacted.
3. Some variants of the equipment have reduced markings on the nameplate. Refer to the Certificate for full equipment marking.

**I1** ATEX Intrinsic Safety and Dust

Certificate: BAS97ATEX1089X; Baseefa11ATEX0275X

Standards: EN60079-0:2012, EN60079-11:2012, EN60079-31:2009

Markings: HART:  II 1 G Ex ia IIC Ga T4 (-60 °C ≤ T<sub>a</sub> ≤ +60 °C)Fieldbus/PROFIBUS:  II 1 G Ex ia IIC Ga T4 (-60 °C ≤ T<sub>a</sub> ≤ +60 °C)DUST:  II 1 D Ex ta IIIC T95 °C T<sub>500</sub> 105 °C Da (-20 °C ≤ T<sub>a</sub> ≤ +85 °C)**Table 5. Input Parameters**

Parameter	HART	Fieldbus/PROFIBUS
Voltage U <sub>i</sub>	30 V	30 V
Current I <sub>i</sub>	200 mA	300 mA
Power P <sub>i</sub>	0.9 W	1.3 W
Capacitance C <sub>i</sub>	0.012 μF	0 μF
Inductance L <sub>i</sub>	0 mH	0 mH

**Special Conditions for Safe Use (X):**

1. The apparatus is not capable of withstanding the 500 V insulation test required by clause 6.3.12 of EN60079-11:2012. This must be taken into account when installing the apparatus.
2. The enclosure may be made of aluminum alloy and given a protective polyurethane paint finish; however care should be taken to protect it from impact or abrasion if located in Zone 0.
3. Some variants of the equipment have reduced markings on the nameplate. Refer to the Certificate for full equipment marking.

**IA** ATEX FISCO

Certificate: BAS 98ATEX1355X

Standards: EN60079-0:2012, EN60079-11:2009

Markings:  II 1 G Ex ia IIC T4 Ga (-60 °C ≤ T<sub>a</sub> ≤ +60 °C)**Table 6. Input Parameters**

Parameter	FISCO
Voltage U <sub>i</sub>	17.5 V
Current I <sub>i</sub>	380 mA
Power P <sub>i</sub>	5.32 W
Capacitance C <sub>i</sub>	< 5 nF
Inductance L <sub>i</sub>	< 10 μH

**Special Conditions for Safe Use (X):**

1. The apparatus is not capable of withstanding the 500 V insulation test required by clause 6.3.12 of EN60079-11:2012. This must be taken into account when installing the apparatus.
2. The enclosure may be made of aluminum alloy and given a protective polyurethane paint finish; however care should be taken to protect it from impact or abrasion if located in Zone 0.



**N1** ATEX Type n and Dust

Certificate: BAS00ATEX3105X; Baseefa11ATEX0275X

Standards: EN60079-0:2012, EN60079-15:2010, EN60079-31:2009

Markings:  II 3 G Ex nA IIC T5 Gc (-40 °C ≤ T<sub>a</sub> ≤ +70 °C);

 II 1 D Ex ta IIIC T95 °C T<sub>500</sub> 105 °C Da (-20 °C ≤ T<sub>a</sub> ≤ +85 °C)

**Special Conditions for Safe Use (X):**

1. This apparatus is not capable of withstanding the 500 V insulation test that is required by clause 6.8.1 of EN60079-15. This must be taken into account when installing the apparatus.
2. Some variants of the equipment have reduced markings on the nameplate. Refer to the Certificate for full equipment marking.

## 7.5 International

**E7** IECEx Flameproof and Dust

Certificate: IECEx KEM 09.0034X; IECEx BAS 10.0034X

Standards: IEC60079-0:2011, IEC60079-1:2007-04, IEC60079-26:2006, IEC60079-31:2008

Markings: Ex d IIC T6/T5 Ga/Gb, T6(-50 °C ≤ T<sub>a</sub> ≤ +65 °C), T5(-50 °C ≤ T<sub>a</sub> ≤ +80 °C);

Ex ta IIIC T95 °C T<sub>500</sub> 105 °C Da (-20 °C ≤ T<sub>a</sub> ≤ +85 °C)

**Table 7. Process Temperature**

Temperature class	Process temperature
T6	-50 °C to +65 °C
T5	-50 °C to +80 °C

**Special Conditions for Safe Use (X):**

1. This device contains a thin wall diaphragm. Installation, maintenance and use shall take into account the environmental conditions to which the diaphragm will be subjected. The manufacturer’s instructions for installation and maintenance shall be followed in detail to assure safety during its expected lifetime.
2. For information on the dimensions of the flameproof joints the manufacturer shall be contacted.
3. Some variants of the equipment have reduced markings on the nameplate. Refer to the Certificate for full equipment marking.

**I7** IECEx Intrinsic Safety

Certificate: IECEx BAS 09.0076X

Standards: IEC60079-0:2011, IEC60079-11:2011

Markings: HART: Ex ia IIC T5/T4 Ga, T5(-60 °C ≤ T<sub>a</sub> ≤ +40 °C), T4(-60 °C ≤ T<sub>a</sub> ≤ +70 °C)

Fieldbus/PROFIBUS: Ex ia IIC T4(-60 °C ≤ T<sub>a</sub> ≤ +60 °C)

**Table 8. Input Parameters**

Parameter	HART	Fieldbus/PROFIBUS
Voltage U <sub>i</sub>	30 V	30 V
Current I <sub>i</sub>	200 mA	300 mA
Power P <sub>i</sub>	0.9 W	1.3 W
Capacitance C <sub>i</sub>	0.012 μF	0 μF
Inductance L <sub>i</sub>	0 mH	0 mH

**Special Conditions for Safe Use (X):**

1. If the apparatus is fitted with an optional 90 V transient suppressor, it is not capable of withstanding the 500 V insulation test required by clause 6.3.12 of IEC60079-11. This must be taken into account when installing the apparatus.
2. The enclosure may be made of aluminum alloy and given a protective polyurethane paint finish; however, care should be taken to protect it from impact or abrasion if located in Zone 0.

IECEx Mining (Special A0259)

Certificate: IECEx TSA 14.0001X

Standards: IEC60079-0:2011, IEC60079-11:2011

Markings: Ex ia I Ma ( $-60\text{ }^{\circ}\text{C} \leq T_a \leq +70\text{ }^{\circ}\text{C}$ )

**Table 9. Input Parameters**

Parameter	HART	Fieldbus/PROFIBUS	FISCO
Voltage $U_i$	30 V	30 V	17.5 V
Current $I_i$	200 mA	300 mA	380 mA
Power $P_i$	0.9 W	1.3 W	5.32 W
Capacitance $C_i$	0.012 $\mu\text{F}$	0 $\mu\text{F}$	< 5 nF
Inductance $L_i$	0 mH	0 mH	< 10 $\mu\text{H}$

**Special Conditions for Safe Use (X):**

1. If the apparatus is fitted with an optional 90 V transient suppressor, it is not capable of withstanding the 500 V insulation test required by IEC60079-11. This must be taken into account when installing the apparatus.
2. It is a condition of safe use that the above input parameters shall be taken into account during installation.
3. It is a condition of manufacture that only the apparatus fitted with housing, covers and sensor module housing made out of stainless steel are used in Group I applications

**N7 IECEx Type n**

Certificate: IECEx BAS 09.0077X

Standards: IEC60079-0:2011, IEC60079-15:2010

Markings: Ex nA IIC T5 Gc ( $-40\text{ }^{\circ}\text{C} \leq T_a \leq +70\text{ }^{\circ}\text{C}$ )

**Special Condition for Safe Use (X):**

1. The apparatus is not capable of withstanding the 500 V insulation test required by IEC60079-15. This must be taken into account when installing the apparatus.

## 7.6 Brazil

**E2 INMETRO Flameproof**

Certificate: UL-BR 13.0643X

Standards: ABNT NBR IEC60079-0:2008 + Errata 1:2011,

ABNT NBR IEC60079-1:2009 + Errata 1:2011,

ABNT NBR IEC60079-26:2008 + Errata 1:2008

Markings: Ex d IIC T6/T5 Ga/Gb, T6 ( $-50\text{ }^{\circ}\text{C} \leq T_a \leq +65\text{ }^{\circ}\text{C}$ ), T5 ( $-50\text{ }^{\circ}\text{C} \leq T_a \leq +80\text{ }^{\circ}\text{C}$ )

**Special Conditions for Safe Use (X):**

1. This device contains a thin wall diaphragm. Installation, maintenance and use shall take into account the environmental conditions to which the diaphragm will be subjected. The manufacturer's instructions for installation and maintenance shall be followed in detail to assure safety during its expected lifetime.

2. In case of repair, contact the manufacturer for information on the dimensions of the flameproof joints.
3. The capacitance of the wrap around label, being 1.6nF, exceeds the limit in Table 9 of ABNT NBR IEC 60079-0. The user shall determine suitability for the specific application.

**12 INMETRO Intrinsic Safety**

Certificate: UL-BR 13.0584X

Standards: ABNT NBR IEC60079-0:2008 + Errata 1:2011, ABNT NBR IEC60079-11:2009

Markings: HART: Ex ia IIC T5/T4 Ga, T5(-60 °C ≤ T<sub>a</sub> ≤ +40 °C), T4(-60 °C ≤ T<sub>a</sub> ≤ +70 °C)

Fieldbus/PROFIBUS: Ex ia IIC T4 Ga (-60 °C ≤ T<sub>a</sub> ≤ +60 °C)

**Table 10. Input Parameters**

Parameter	HART	Fieldbus/PROFIBUS
Voltage U <sub>i</sub>	30 V	30 V
Current I <sub>i</sub>	200 mA	300 mA
Power P <sub>i</sub>	0.9 W	1.3 W
Capacitance C <sub>i</sub>	0.012 μF	0 μF
Inductance L <sub>i</sub>	0 mH	0 mH

**Special Conditions for Safe Use (X):**

1. If the equipment is fitted with an optional 90 V transient suppressor, it is not capable of withstanding the 500 V insulation test required by ABNT NBR IRC 60079-11. This must be taken into account when installing the equipment.
2. The enclosure may be made of aluminum alloy and given a protective polyurethane paint finish; however, care should be taken to protect it from impact or abrasion if located in Zone 0.

**1B INMETRO FISCO**

Certificate: UL-BR 13.0584X

Standards: ABNT NBR IEC60079-0:2008 + Errata 1:2011, ABNT NBR IEC60079-11:2009

Markings: Ex ia IIC T4 Ga (-60 °C ≤ T<sub>a</sub> ≤ +60 °C)

**Table 11. Input Parameters**

Parameter	FISCO
Voltage U <sub>i</sub>	17.5 V
Current I <sub>i</sub>	380 mA
Power P <sub>i</sub>	5.32 W
Capacitance C <sub>i</sub>	< 5 nF
Inductance L <sub>i</sub>	< 10 μH

**Special Conditions for Safe Use (X):**

1. If the equipment is fitted with an optional 90V transient suppressor, it is not capable of withstanding the 500 V insulation test required by ABNT NBR IEC 60079-11. This must be taken into account when installing the equipment.
2. The enclosure may be made of aluminum alloy and given a protective polyurethane paint finish; however, care should be taken to protect it from impact or abrasion if located in Zone 0.

## 7.7 China

### E3 China Flameproof

Certificate: GYJ14.1041X; GYJ15.1368X [Flowmeters]

Standards: GB12476-2000; GB3836.1-2010, GB3836.2-2010, GB3836.20-2010

Markings: Ex d IIC T6/T5 Ga/Gb, T6(-50 °C ≤ T<sub>a</sub> ≤ +65 °C), T5(-50 °C ≤ T<sub>a</sub> ≤ +80 °C)

#### Special Conditions for Safe Use (X):

- The relation between ambient temperature arrange and temperature class is as follows:

T <sub>a</sub>	Temperature class
-50 °C ≤ T <sub>a</sub> ≤ +80 °C	T5
-50 °C ≤ T <sub>a</sub> ≤ +65 °C	T6

When used in a combustible dust environment, the maximum ambient temperature is 80 °C.

- The earth connection facility in the enclosure should be connected reliably.
- Cable entry certified by notified body with type of protection Ex d IIC in accordance with GB3836.1-2000 and GB3836.2-2000, should be applied when installed in a hazardous location. When used in combustible dust environment, cable entry in accordance with IP66 or higher level should be applied.
- Obey the warning “Keep tight when the circuit is alive.”
- End users are not permitted to change any internal components.
- During installation, use and maintenance of this product, observe the following standards: GB3836.13-1997, GB3836.15-2000, GB3836.16-2006, GB50257-1996, GB12476.2-2006, GB15577-2007.

### I3 China Intrinsic Safety

Certificate: GYJ13.1362X; GYJ15.1367X [Flowmeters]

Standards: GB3836.1-2010, GB3836.4-2010, GB3836.20-2010, GB12476.1-2000

Markings: Ex ia IIC Ga T4/T5

#### Special Conditions for Safe Use (X):

- Symbol “X” is used to denote specific conditions of use:
  - If the apparatus is fitted with an optional 90 V transient suppressor, it is not capable of withstanding the 500 V insulation test for 1 minute. This must be taken into account when installing the apparatus.
  - The enclosure may be made of aluminum alloy and given a protective polyurethane paint finish; however, care should be taken to protect it from impact or abrasion if located in Zone 0.
- The relation between T code and ambient temperature range is:

Model	T code	Temperature range
HART	T5	-60 °C ≤ T <sub>a</sub> ≤ +40 °C
HART	T4	-60 °C ≤ T <sub>a</sub> ≤ +70 °C
Fieldbus/PROFIBUS/FISCO	T4	-60 °C ≤ T <sub>a</sub> ≤ +60 °C

- Intrinsically Safe parameters:

Parameter	HART	Fieldbus/PROFIBUS	FISCO
Voltage U <sub>i</sub>	30 V	30 V	17.5 V
Current I <sub>i</sub>	200 mA	300 mA	380 mA
Power P <sub>i</sub>	0.9 W	1.3 W	5.32 W

Parameter	HART	Fieldbus/PROFIBUS	FISCO
Capacitance $C_i$	0.012 $\mu\text{F}$	0 $\mu\text{F}$	< 5 nF
Inductance $L_i$	0 mH	0 mH	< 10 $\mu\text{H}$

Note 1: FISCO parameters apply to both Group IIC and IIB.

Note 2: [For Flowmeters] When Rosemount 644 Temperature Transmitter is used, the Rosemount 644 should be used with Ex-certified associated apparatus to establish explosion protection system that can be used in explosive gas atmospheres. Wiring and terminals should comply with the instruction manual of both Rosemount 644 and associated apparatus. The cables between Rosemount 644 and associated apparatus should be shielded cables (the cables must have insulated shield). The shielded cable has to be grounded reliably in a non-hazardous area.

- Transmitters comply with the requirements for FISCO field devices specified in IEC60079-27:2008. For the connection of an intrinsically safe circuit in accordance with FISCO Model, FISCO parameters are listed in the table above.
- The product should be used with Ex-certified associated apparatus to establish explosion protection system that can be used in explosive gas atmospheres. Wiring and terminals should comply with the instruction manual of the product and associated apparatus.
- The cables between this product and associated apparatus should be shielded cables (the cables must have insulated shield). The shielded cable has to be grounded reliably in a non-hazardous area.
- End users are not permitted to change any intern components but to settle the problem in conjunction with the manufacturer to avoid damage to the product.
- During installation, use and maintenance of this product, observe the following standards: GB3836.13-1997, GB3836.15-2000, GB3836.16-2006, GB50257-1996, GB12476.2-2006, GB15577-2007

### N3 China Type n

Certificate: GYJ15.1105X

Standards: GB3836.1-2010, GB3836.8-2003

Markings: Ex nA nL IIC T5 Gc ( $-40\text{ }^{\circ}\text{C} \leq T_a \leq +70\text{ }^{\circ}\text{C}$ )

### Special Condition for Safe Use (X):

- Symbol "X" is used to denote specific conditions of use: The apparatus is not capable of withstanding the 500 V test to earth for one minute. The must be taken into consideration during installation.

## 7.8 Japan

### E4 Japan Flameproof

Certificate: TC20577, TC20578, TC20583, TC20584 [HART]; TC20579, TC20580, TC20581, TC20582 [Fieldbus]

Markings: Ex d IIC T5

## 7.9 Technical Regulations Customs Union (EAC)

### EM EAC Flameproof

Certificate: RU C-US.GB05.B.01197

Markings: Ga/Gb Ex d IIC T5/T6 X, T5 ( $-60\text{ }^{\circ}\text{C} \leq T_a \leq +80\text{ }^{\circ}\text{C}$ ), T6 ( $-60\text{ }^{\circ}\text{C} \leq T_a \leq +65\text{ }^{\circ}\text{C}$ )

### Special Condition for Safe Use (X):

- See certificate for special conditions.

**IM** EAC Intrinsically Safe

Certificate: RU C-US.GB05.B.01197

Markings: HART: 0Ex ia IIC T4/T5 Ga X, T4(-60 °C ≤ T<sub>a</sub> ≤ +70 °C), T5(-60 °C ≤ T<sub>a</sub> ≤ +40 °C)  
Fieldbus/PROFIBUS: 0Ex ia IIC T4 Ga X (-60 °C ≤ T<sub>a</sub> ≤ +60 °C)**Special Condition for Safe Use (X):**

1. See certificate for special conditions.

## 7.10 Combinations

- K2** Combination of E2 and I2  
**K5** Combination of E5 and I5  
**K6** Combination of C6, E8, and I1  
**K7** Combination of E7, I7, and N7  
**K8** Combination of E8, I1, and N1  
**KB** Combination of E5, I5, and C6  
**KD** Combination of E8, I1, E5, I5, and C6  
**KM** Combination of EM and IM

## 7.11 Conduit Plugs and Adapters

IECEx Flameproof and Increased Safety

Certificate: IECEx FMG 13.0032X

Standards: IEC60079-0:2011, IEC60079-1:2007, IEC60079-7:2006-2007

Markings: Ex de IIC Gb

ATEX Flameproof and Increased Safety

Certificate: FM13ATEX0076X

Standards: EN60079-0:2012, EN60079-1:2007, IEC60079-7:2007

Markings:  II 2 G Ex de IIC Gb

**Table 12. Conduit Plug Thread Sizes**

Thread	Identification mark
M20 × 1.5	M20
1/2-14 NPT	1/2 NPT

**Table 13. Thread Adapter Thread Sizes**

Male thread	Identification mark
M20 × 1.5- 6H	M20
1/2-14 NPT	1/2-14 NPT
3/4-14 NPT	3/4-14 NPT
Female thread	Identification mark
M20 × 1.5-6H	M20
1/2-14 NPT	1/2-14 NPT
G1/2	G1/2

**Special Conditions for Safe Use (X):**

1. When the thread adapter or blanking plug is used with an enclosure in type of protection increased safety “e” the entry thread shall be suitably sealed in order to maintain the ingress protection rating (IP) of the enclosure.
2. The blanking plug shall not be used with an adapter.
3. Blanking Plug and Threaded Adapter shall be either NPT or Metric thread forms. G1/2 thread forms are only acceptable for existing (legacy) equipment installations.



## 7.12 Additional Certifications

- SBS** American Bureau of Shipping (ABS) Type Approval  
 Certificate: 09-HS446883A-5-PDA  
 Intended Use: Marine & Offshore Applications – Measurement of either gauge or absolute pressure for liquid, gas, and vapor.
  
- SBV** Bureau Veritas (BV) Type Approval  
 Certificate: 23155  
 BV Rules: Bureau Veritas Rules for the Classification of Steel Ships  
 Requirements: Bureau Veritas Rules for the Classification of Steel Ships  
 Application: Class notations: AUT-UMS, AUT-CCS, AUT-PORT and AUT-IMS; Pressure transmitter type 3051 cannot be installed on diesel engines
  
- SDN** Det Norske Veritas (DNV) Type Approval  
 Certificate: TAA000004F  
 Intended Use: DNV GL Rules for Classification – Ships and offshore units  
 Application:

Location classes	
Temperature	D
Humidity	B
Vibration	A
EMC	B
Enclosure	D

- SLL** Lloyds Register (LR) Type Approval  
 Certificate: 11/60002  
 Application: Environmental categories ENV1, ENV2, ENV3, and ENV5
  
- C5** Custody Transfer - Measurement Canada Accuracy Approval  
 Certificate: AG-0226; AG-0454; AG-0477

Figure 9. Rosemount 3051 Declaration of Conformity

	<b>EU Declaration of Conformity</b> No: RMD 1017 Rev. X	
<p>We,</p> <p><b>Rosemount, Inc.</b> 8200 Market Boulevard Chanhassen, MN 55317-9685 USA</p> <p>declare under our sole responsibility that the product,</p> <p><b>Rosemount 3051 Pressure Transmitters</b></p> <p>manufactured by,</p> <p><b>Rosemount, Inc.</b> 8200 Market Boulevard Chanhassen, MN 55317-9685 USA</p> <p>to which this declaration relates, is in conformity with the provisions of the European Union Directives, including the latest amendments, as shown in the attached schedule.</p> <p>Assumption of conformity is based on the application of the harmonized standards and, when applicable or required, a European Union notified body certification, as shown in the attached schedule.</p>		
 (signature)	Vice President of Global Quality (function)	
Kelly Klein (name)	19 Apr 2016 (date of issue)	
Page 1 of 4		





## EU Declaration of Conformity

No: RMD 1017 Rev. X



**EMC Directive (2004/108/EC) *This directive is valid until 19 April 2016***

**EMC Directive (2014/30/EU) *This directive is valid from 20 April 2016***

Harmonized Standards: EN 61326-1:2013, EN 61326-2-3:2013

**PED Directive (97/23/EC) *This directive is valid until 18 July 2016***

**PED Directive (2014/68/EU) *This directive is valid from 19 July 2016***

**Rosemount 3051CA4; 3051CD2, 3, 4, 5; 3051HD2, 3, 4, 5; (also with P9 option)**  
QS Certificate of Assessment - EC Certificate No. 59552-2009-CE-HOU-DNV  
Module H Conformity Assessment  
Other Standards Used: ANSI/ISA61010-1:2004

**All other Rosemount 3051 Pressure Transmitters**  
Sound Engineering Practice

**Transmitter Attachments: Diaphragm Seal, Process Flange, or Manifold**  
Sound Engineering Practice

**Rosemount 3051CFx DP Flowmeters**  
See DSI 1000 Declaration of Conformity



## EU Declaration of Conformity

No: RMD 1017 Rev. X



**ATEX Directive (94/9/EC) This directive is valid until 19 April 2016**

**ATEX Directive (2014/34/EU) This directive is valid from 20 April 2016**

**BAS97ATEX1089X - Intrinsic Safety**

Equipment Group II Category I G

Ex ia IIC T5/T4 Ga

Harmonized Standards Used:

EN60079-0:2012, EN60079-11:2012

**BAS00ATEX3105X - Type n and Certificate**

Equipment Group II Category 3 G

Ex nA IIC T5 Gc

Harmonized Standards Used:

EN60079-0:2012, EN60079-15:2010

**Baseefa11ATEX0275X - Dust Certificate**

Equipment Group II Category I D

Ex ta IIIC T95°C T<sub>300</sub>105°C Da

Harmonized Standards Used:

EN60079-0:2012, EN60079-31:2009

**KEMA00ATEX2013X - Flameproof Certificate**

Equipment Group II Category 1/2 G

Ex d IIC T6/T5 Ga/Gb

Harmonized Standards Used:

EN60079-0:2012, EN60079-1:2007, EN60079-26:2007



## EU Declaration of Conformity



No: RMD 1017 Rev. X

---

### PED Notified Body

**Det Norske Veritas (DNV)** [Notified Body Number: 0575]  
Veritasveien 1, N-1322  
Hovik, Norway

---

### ATEX Notified Bodies

**DEKRA** [Notified Body Number: 0344]  
Utrechtseweg 310, 6812 AR Arnhem  
P.O. Box 5185, 6802 ED Arnhem  
The Netherlands  
Postbank 6794687

**SGS Baseefa Limited** [Notified Body Number: 1180]  
Rockhead Business Park  
Staden Lane  
Buxton, Derbyshire  
SK17 9RZ United Kingdom

---

### ATEX Notified Body for Quality Assurance

**SGS Baseefa Limited** [Notified Body Number: 1180]  
Rockhead Business Park  
Staden Lane  
Buxton, Derbyshire  
SK17 9RZ United Kingdom

含有China RoHS管控物质超过最大浓度限值的部件型号列表 Rosemount 3051  
List of Rosemount 3051 Parts with China RoHS Concentration above MCVs

部件名称 Part Name	有害物质 / Hazardous Substances					
	铅 Lead (Pb)	汞 Mercury (Hg)	镉 Cadmium (Cd)	六价铬 Hexavalent Chromium (Cr +6)	多溴联苯 Polybrominated biphenyls (PBB)	多溴联苯醚 Polybrominated diphenyl ethers (PBDE)
电子组件 Electronics Assembly	X	O	O	O	O	O
壳体组件 Housing Assembly	X	O	O	X	O	O
传感器组件 Sensor Assembly	X	O	O	X	O	O

本表格系依据SJ/T11364的规定而制作。

This table is proposed in accordance with the provision of SJ/T11364.

O: 意为该部件的所有均质材料中该有害物质的含量均低于GB/T 26572所规定的限量要求。

O: Indicate that said hazardous substance in all of the homogeneous materials for this part is below the limit requirement of GB/T 26572.

X: 意为在该部件所使用的的所有均质材料里，至少有一类均质材料中该有害物质的含量高于GB/T 26572所规定的限量要求。

X: Indicate that said hazardous substance contained in at least one of the homogeneous materials used for this part is above the limit requirement of GB/T 26572.





### Global Headquarters

#### Emerson Process Management

6021 Innovation Blvd.  
Shakopee, MN 55379, USA  
+1 800 999 9307 or +1 952 906 8888  
+1 952 949 7001  
RFQ.RMD-RCC@EmersonProcess.com

### North America Regional Office

#### Emerson Process Management

8200 Market Blvd.  
Chanhassen, MN 55317, USA  
+1 800 999 9307 or +1 952 906 8888  
+1 952 949 7001  
RMT-NA.RCCRFQ@Emerson.com

### Latin America Regional Office

#### Emerson Process Management

1300 Concord Terrace, Suite 400  
Sunrise, FL 33323, USA  
+1 954 846 5030  
+1 954 846 5121  
RFQ.RMD-RCC@EmersonProcess.com

### Europe Regional Office

#### Emerson Process Management Europe GmbH

Neuhofstrasse 19a P.O. Box 1046  
CH 6340 Baar  
Switzerland  
+41 (0) 41 768 6111  
+41 (0) 41 768 6300  
RFQ.RMD-RCC@EmersonProcess.com

### Asia Pacific Regional Office

#### Emerson Process Management Asia Pacific Pte Ltd

1 Pandan Crescent  
Singapore 128461  
+65 6777 8211  
+65 6777 0947  
Enquiries@AP.EmersonProcess.com

### Middle East and Africa Regional Office

#### Emerson Process Management

Emerson FZE P.O. Box 17033,  
Jebel Ali Free Zone - South 2  
Dubai, United Arab Emirates  
+971 4 8118100  
+971 4 8865465  
RFQ.RMTMEA@Emerson.com



Linkedin.com/company/Emerson-Process-Management



Twitter.com/Rosemount\_News



Facebook.com/Rosemount



Youtube.com/user/RosemountMeasurement



Google.com/+RosemountMeasurement

Standard Terms and Conditions of Sale can be found at

[www.Emerson.com/en-us/pages/Terms-of-Use](http://www.Emerson.com/en-us/pages/Terms-of-Use)

The Emerson logo is a trademark and service mark of Emerson Electric Co.

Rosemount and Rosemount logotype are trademarks of Emerson Process Management.

PROFIBUS is a registered trademark of PROFINET International (PI).

DTM is a trademark of the FDT Group.

FOUNDATION Fieldbus is a trademark of the FieldComm Group.

All other marks are the property of their respective owners.

© 2016 Emerson Process Management. All rights reserved.