

# Rosemount™ 3051HT Hygienic Pressure Transmitter

with 4–20 mA HART® Revision 5 and 7 Protocol



---

## Note

Before installing the transmitter, confirm the correct device driver is loaded on the host systems. See [page 3](#) for system readiness.

---

**NOTICE**

This guide provides basic guidelines for the Rosemount 3051HT Transmitter. It does not provide instructions for configuration, diagnostics, maintenance, service, troubleshooting, Explosion-proof, Flameproof, or intrinsically safe (I.S.) installations.

**▲ WARNING**

**Explosions could result in death or serious injury.**

Installation of this transmitter in an explosive environment must be in accordance with the appropriate local, national, and international standards, codes, and practices.

- Before connecting a HART-based communicator in an explosive atmosphere, make sure the instruments in the loop are installed in accordance with intrinsically safe or non-incendive field wiring practices.
- In an Explosion-proof/Flameproof installation, do not remove the transmitter covers when power is applied to the unit.

**Process leaks may cause harm or result in death.**

- To avoid process leaks, only use the gasket designed to seal with the corresponding flange adapter.

**Electrical shock can result in death or serious injury.**

- Avoid contact with the leads and the terminals. High voltage that may be present on leads can cause electrical shock.

**Conduit/cable entries**

- Unless marked, the conduit/cable entries in the transmitter housing use a 1/2–14 NPT thread form. Only use plugs, adapters, glands, or conduit with a compatible thread form when closing these entries.

**Contents**

System readiness .....	3	Connect the wiring and power up .....	7
Transmitter installation .....	4	Verify configuration .....	9
Mount the transmitter .....	4	Trim the transmitter .....	12
Set the switches .....	5	Product Certifications .....	14

# 1.0 System readiness

## 1.1 Confirm HART Revision capability

- If using HART based control or asset management systems, confirm the HART capability of those systems prior to transmitter installation. Not all systems are capable of communicating with HART Revision 7 protocol. This transmitter can be configured for either HART Revision 5 or 7.
- For instructions on how to change the HART Revision of your transmitter, see page 11.

## 1.2 Confirm correct device driver

- Verify the latest device driver (DD/DTM™) is loaded on your systems to ensure proper communications.
- Download the latest device driver at [Emerson.com](http://Emerson.com) or [hartcomm.org](http://hartcomm.org).

### Rosemount 3051 device revisions and drivers

Table 1 provides the information necessary to ensure you have the correct device driver and documentation for your device.

**Table 1. Rosemount 3051 Device Revisions and Files**

	Identify device	Find device driver		Review functionality
Software release date	HART software Revision	HART universal Revision	Device Revision <sup>(1)</sup>	Changes to software <sup>(2)</sup>
Dec-11	01	7	10	See <a href="#">Footnote 2</a> for list of changes.
		5	9	

1. Device driver file names use device and DD revision, e.g. 10\_01. HART Protocol is designed to enable legacy device driver revisions to continue to communicate with new HART devices. To access new functionality, the new device driver must be downloaded. It is recommended to download new device driver files to ensure full functionality.
2. HART Revision 5 and 7 Selectable, PowerDiagnostics, Safety Certified, Local Operator Interface, Process Alerts, Scaled Variable, Configurable Alarms, Expanded Engineering Units.

## 2.0 Transmitter installation

### 2.1 Mount the transmitter

Orient the transmitter to desired orientation before mounting. Transmitter must not be securely mounted or clamped in place when changing transmitter orientation.

#### Conduit entry orientation

When installing a Rosemount 3051HT, it is recommended installing so the conduit entry faces downward or parallel to the ground to maximize drainability when cleaning.

#### Environmental seal for housing

Thread sealing (PTFE) tape or paste on male threads of conduit is required to provide a water/dust tight conduit seal and meets requirements of NEMA® Type 4X, IP66, IP68, and IP69K. Consult factory if other Ingress Protection ratings are required.

---

#### Note

IP69K rating only available on units with a SST housing and option code V9 in the model string.

---

For M20 threads, install conduit plugs to full thread engagement or until mechanical resistance is met.

#### In-line gage transmitter orientation

The low side pressure port (atmospheric reference) on the in-line gage transmitter is located on the neck of the transmitter via a protected gage vent (See Figure 1).

Keep the vent path free from obstructions including but not limited to paint, dust, and viscous fluids by mounting the transmitter so the process can drain away.

---

**Figure 1. In-line Protected Gage Vent Low Side Pressure Port**

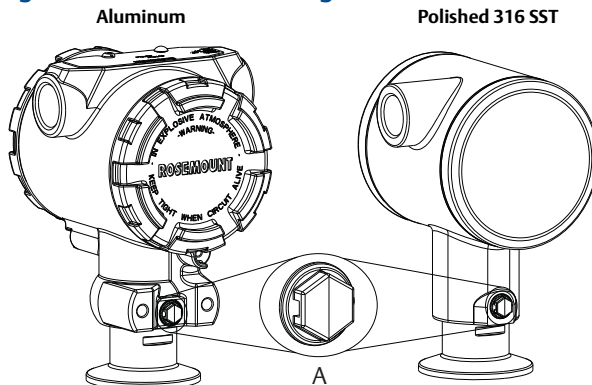

A. Low side pressure port (atmospheric reference)

---

## Clamping

When installing clamp, follow recommended torque values provided by gasket manufacturer<sup>(1)</sup>.

## 2.2 Set the switches

Set alarm and security switch configuration before installation as shown in Figure 2.

- The alarm switch sets the analog output alarm to high or low.
  - Default alarm is high.
- The security switch allows (unlocked symbol) or prevents (locked symbol) any configuration of the transmitter.
  - Default security is off (unlocked symbol).

Use the following procedure to change the switch configuration:

1. If the transmitter is installed, secure the loop and remove power.
2. Remove the housing cover opposite the field terminal side. Do not remove the instrument cover in explosive atmospheres when the circuit is live.
3. Slide the security and alarm switches into the preferred position using a small screwdriver.
4. Reattach the transmitter cover.
  - The covers must only be capable of being released or removed with the aid of a tool to comply with applicable ordinary locations requirements.
  - The cover must be fully engaged to comply with explosion-proof requirements.

1. To maintain transmitter performance, torquing a 1.5-in. Tri Clamp beyond 50 in-lb is not recommended on pressure ranges below 20 psi.

**Figure 2. Transmitter Electronics Board**

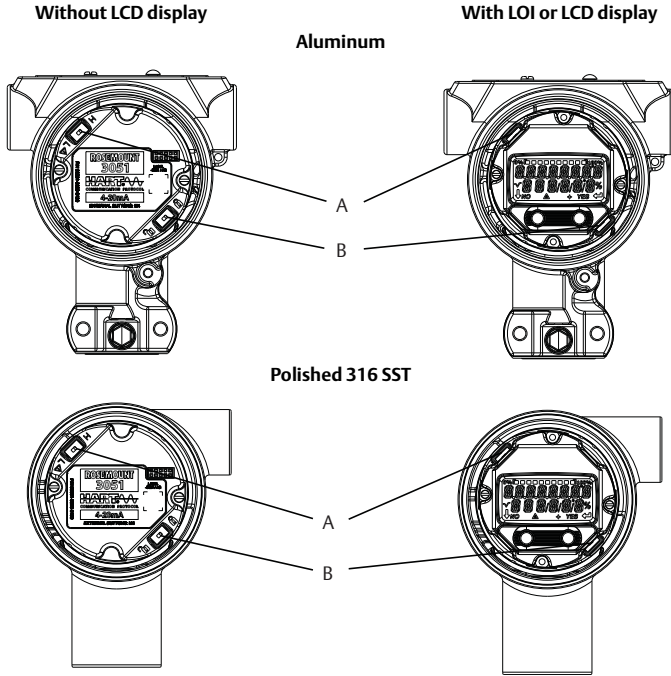

- A. Alarm
- B. Security

## 2.3 Connect the wiring and power up

**Figure 3. Transmitter Wiring Diagrams (4–20 mA)**

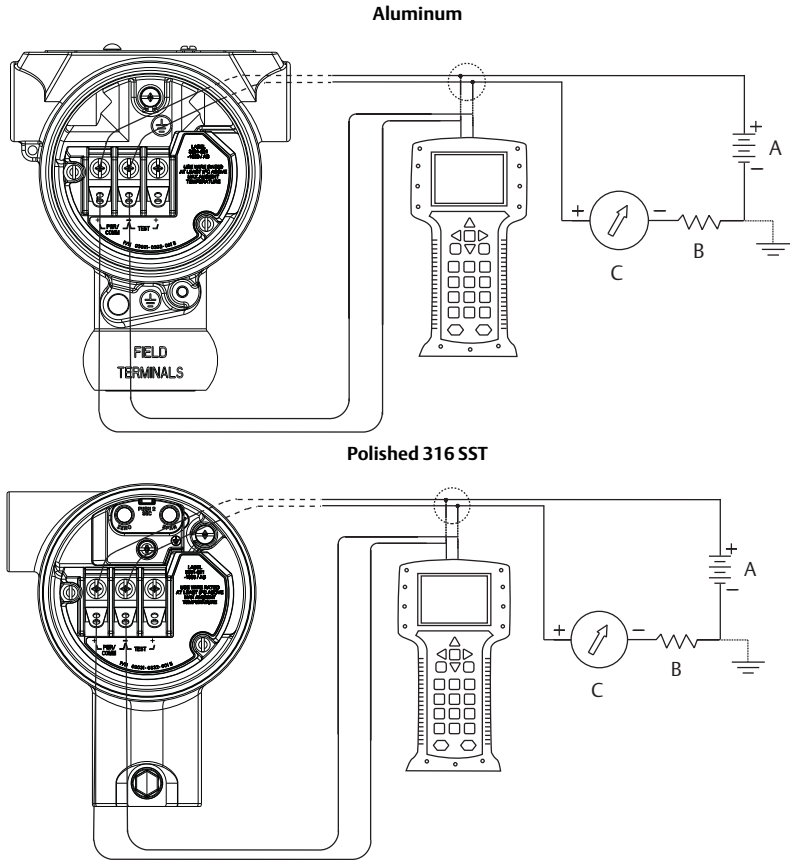

- A. 24 Vdc supply  
 B.  $R_L \geq 250$   
 C. Current meter (optional)

Shielded twisted pair cable should be used for best results. Use 24 AWG or larger wire that does not exceed 5,000 ft. (1,500 m) in length. If applicable, install wiring with a drip loop. Arrange the drip loop so the bottom is lower than the conduit connections and the transmitter housing.

### **CAUTION**

- Installation of the transient protection terminal block does not provide transient protection unless the Rosemount 3051HT case is properly grounded.
- Do not run signal wiring in conduit or open trays with power wiring, or near heavy electrical equipment.
- Do not connect the powered signal wiring to the test terminals. Power could damage the test diode in the terminal block.

Use the following steps to wire the transmitter:

1. Remove the housing cover on the FIELD TERMINALS side.
2. Connect the positive lead to the “+” terminal (PWR/COMM) and the negative lead to the “-” terminal.
3. Ensure full contact with Terminal Block screw and washer. When using a direct wiring method, wrap wire clockwise to ensure it is in place when tightening the terminal block screw.

### Note

The use of a pin or a ferrule wire terminal is not recommended as the connection may be more susceptible to loosening over time or under vibration.

4. Ground housing to fulfill local grounding regulations.
5. Ensure proper grounding. It is important the instrument cable shield be:
  - Trimmed close and insulated from touching the transmitter housing
  - Connected to the next shield if cable is routed through a junction box
  - Connected to a good earth ground at the power supply end
6. If transient protection is needed, refer to section “[Grounding for transient terminal block](#)” for grounding instructions.
7. Plug and seal unused conduit connections.
8. Reattach the transmitter covers.
  - The covers must only be capable of being released or removed with the aid of a tool to comply with applicable ordinary locations requirements.
  - The cover must be fully engaged to comply with explosion-proof requirements.

**Figure 4. Wiring**

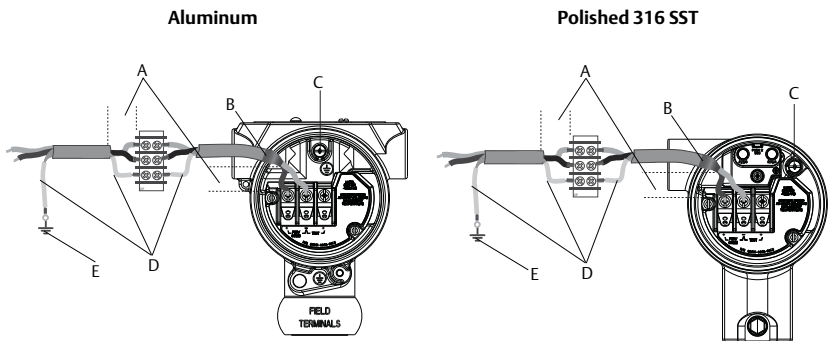

- A. Minimize distance  
 B. Trim shield and insulate  
 C. Protective grounding terminal

- D. Insulate shield  
 E. Connect shield back to the power supply ground



## Grounding for transient terminal block

Ground termination is provided on the outside of the electronics housing and inside the terminal compartment. These grounds are used when the transient protection terminal blocks are installed. It is recommended that 18 AWG or larger wire is used to connect housing ground to earth ground (internal or external).

If the transmitter is currently not wired for power up and communication, follow [Connect the wiring and power up](#), step 1 through 8. When the transmitter is properly wired, refer to [Figure 4](#) for internal and external transient grounding locations.

### Note

The Rosemount 3051HT polished 316 SST housing only provides ground termination inside the terminal compartment.

## 2.4 Verify configuration

Verify the configuration using any HART capable configuration tool or Local Operator Interface (LOI) - option code M4. Configuration instructions for a Field Communicator and LOI are included in this step.

### Verifying configuration with a Field Communicator

A Rosemount 3051 DD must be installed on the Field Communicator to verify configuration. Fast Key sequences for the latest DD are shown in [Table 2 on page 9](#). For Fast Key sequences using legacy DD's, contact your local Emerson™ representative.

### Note

Emerson recommends installing the latest DD to access the complete functionality. Visit [Emerson.com/Field-Communicator](http://Emerson.com/Field-Communicator) for information on updating the DD Library.

1. Verify device configuration using the Fast Key sequences in [Table 2](#).
  - A check (✓) indicates the basic configuration parameters. At minimum, these parameters should be verified as part of configuration and startup.

**Table 2. Device Revision 9 and 10 (HART7), DD Revision 1 Fast Key Sequence**

	Function	Fast Key sequence	
		HART 7	HART 5
✓	Alarm and Saturation Levels	2, 2, 2, 5, 7	2, 2, 2, 5, 7
✓	Damping	2, 2, 1, 1, 5	2, 2, 1, 1, 5
✓	Range Values	2, 2, 2	2, 2, 2
✓	Tag	2, 2, 7, 1, 1	2, 2, 7, 1, 1
✓	Transfer Function	2, 2, 1, 1, 6	2, 2, 1, 1, 6
✓	Units	2, 2, 1, 1, 4	2, 2, 1, 1, 4

**Table 2. Device Revision 9 and 10 (HART7), DD Revision 1 Fast Key Sequence**

Function	Fast Key sequence	
	HART 7	HART 5
Burst Mode	2, 2, 5, 3	2, 2, 5, 3
Custom Display Configuration	2, 2, 4	2, 2, 4
Date	2, 2, 7, 1, 4	2, 2, 7, 1, 3
Descriptor	2, 2, 7, 1, 5	2, 2, 7, 1, 4
Digital to Analog Trim (4–20 mA Output)	3, 4, 2	3, 4, 2
Disable Configuration Buttons	2, 2, 6, 3	2, 2, 6, 3
Rerange with Keypad	2, 2, 2, 1	2, 2, 2, 1
Loop Test	3, 5, 1	3, 5, 1
Lower Sensor Trim	3, 4, 1, 2	3, 4, 1, 2
Message	2, 2, 7, 1, 6	2, 2, 7, 1, 5
Scaled D/A Trim (4–20 mA Output)	3, 4, 2	3, 4, 2
Sensor Temperature/Trend (3051S)	3, 3, 3	3, 3, 3
Upper Sensor Trim	3, 4, 1, 1	3, 4, 1, 1
Digital Zero Trim	3, 4, 1, 3	3, 4, 1, 3
Password	2, 2, 6, 5	2, 2, 6, 4
Scaled Variable	3, 2, 2	3, 2, 2
HART Revision 5 to HART Revision 7 switch	2, 2, 5, 2, 3	2, 2, 5, 2, 3
Long Tag <sup>(1)</sup>	2, 2, 7, 1, 2	N/A
Find Device <sup>(1)</sup>	3, 4, 5	N/A
Simulate Digital Signal <sup>(1)</sup>	3, 4, 5	N/A

1. Only available in HART Revision 7 mode.

## Verifying configuration with LOI

The optional LOI can be used for commissioning the device. The LOI is a two-button design with internal and external/rear buttons. On a polished stainless steel housing, buttons are located internally both on the display and terminal side of the transmitter. On an aluminum housing, buttons are located on the display and externally underneath the top metal tag. To activate the LOI, push any button. LOI button functionality is shown on the bottom corners of the display. See [Table 3](#) and [Figure 5](#) for button operation and menu information.

**Table 3. LOI Button Operation**

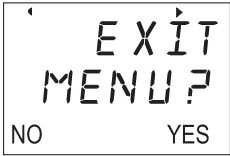
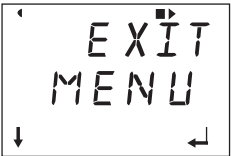
Button		
	Left	No
Right	Yes	ENTER

**Figure 5. LOI Menu**

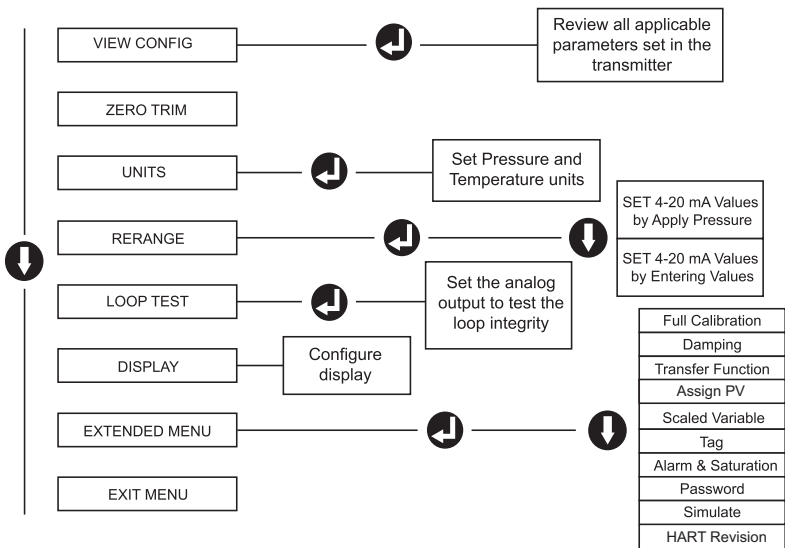

**Switch HART Revision mode**

If the HART configuration tool is not capable of communicating with HART Revision 7, the Rosemount 3051 will load a generic menu with limited capability. The following procedures will switch the HART Revision mode from the generic menu:

1. Manual Setup > Device Information > Identification > Message
  - a. To change to HART Revision 5, Enter: **HART5** in the *Message* field.
  - b. To change to HART Revision 7, Enter: **HART7** in the *Message* field.

**Note**

See [Table 2 on page 9](#) to change HART Revision when the correct device driver is loaded.

## 2.5 Trim the transmitter

Devices are calibrated by the factory. Once installed, it is recommended to perform a zero trim on gage transmitter to eliminate error due to mounting position or static pressure effects. A zero trim can be performed using either a Field Communicator or configuration buttons.

### Note

When performing a zero trim, ensure the equalization valve is open and all wet legs are filled to the correct level.

### CAUTION

It is not recommended to zero an absolute transmitter, Rosemount 3051HTA model.

1. Choose your trim procedure.
  - a. Analog zero trim – Sets the analog output to 4 mA.
    - Also referred to as a “rerange” it sets the lower range value (LRV) equal to the measured pressure.
    - The display and digital HART output remains unchanged.
  - b. Digital zero trim – Recalibrates the sensor zero.
    - The LRV is unaffected. The pressure value will be zero (on display and HART output). 4 mA point may not be at zero.
    - This requires the factory calibrated zero pressure is within a range of 3% of the URL [ $0 \pm 3\% \times \text{URL}$ ].

### Example

URV = 250 inH<sub>2</sub>O

Applied Zero Pressure =  $\pm 0.03 \times 250 \text{ inH}_2\text{O} = \pm 7.5 \text{ inH}_2\text{O}$  (compared to factory settings) values outside this range will be rejected by the transmitter

### Trimming with a Field Communicator

1. Connect the Field Communicator, see “[Connect the wiring and power up](#)” on [page 7](#) for instructions.
2. Follow the HART menu to perform the desired zero trim.

**Table 4. Zero Trim Fast Keys**

	Analog zero (set 4 mA)	Digital zero
Fast Key sequence	3, 4, 2	3, 4, 1, 3

### Trimming with configuration buttons

A zero trim is to be performed using one of the three possible sets of configuration buttons located above the terminal block or under the top tag.

To access the configuration buttons on a polished stainless steel housing, remove the terminal side housing cover.

To access the configuration buttons on an aluminum housing, loosen the screw on the top tag and slide the tag on the top of the transmitter.

**Figure 6. External or Rear/Terminal-Side Configuration Buttons**

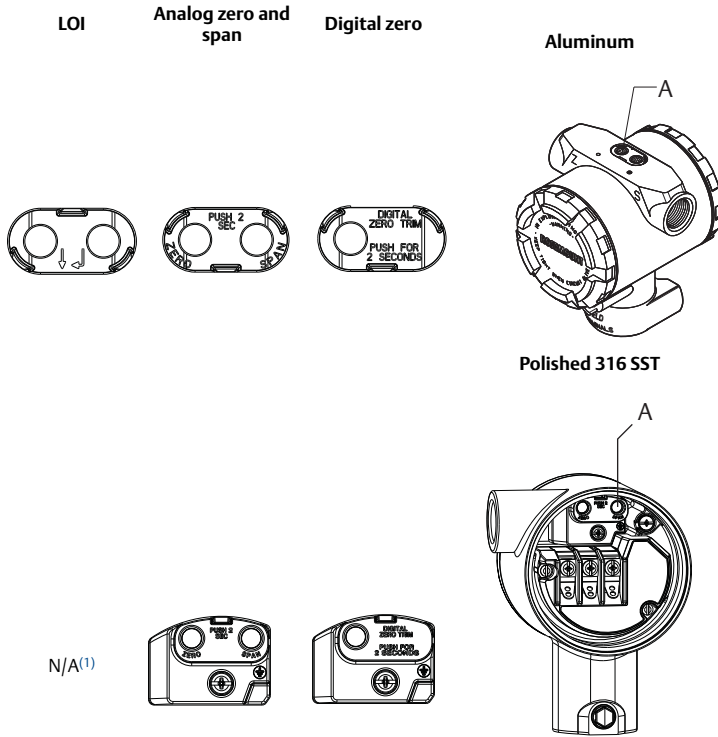

A. Configuration buttons

1. LOI buttons (option M4) only offer front facing buttons on SST housing (option 1). Options D4 and DZ can still be purchased for rear/terminal-side facing buttons.

Use the following procedures to perform a zero trim:

**Perform trim with LOI (option M4)**

1. Set the transmitter pressure.
2. See [Figure 5 on page 11](#) for the operating menu.
  - a. Perform an analog zero trim by selecting **Rerange**.
  - b. Perform a digital zero trim by selecting **Zero Trim**.

**Perform trim with analog zero and span (option D4)**

1. Set the transmitter pressure.
2. Press and hold the **Zero** button for two seconds to perform an analog zero trim.

**Perform trim with digital zero (option DZ)**

1. Set the transmitter pressure.
2. Press and hold the **Zero** button for two seconds to perform a digital zero trim.

## 3.0 Product Certifications

### 3.1 European Directive Information

A copy of the EU Declaration of Conformity can be found at the end of the Quick Start Guide. The most recent revision of the EU Declaration of Conformity can be found at [Emerson.com/Rosemount](http://Emerson.com/Rosemount).

### 3.2 Ordinary Location Certification

As standard, the transmitter has been examined and tested to determine that the design meets the basic electrical, mechanical, and fire protection requirements by a nationally recognized test laboratory (NRTL) as accredited by the Federal Occupational Safety and Health Administration (OSHA).

Altitude	Pollution degree
5000 m max	4 (metallic enclosure) 2 (non-metallic enclosure)

### 3.3 Installing Equipment in North America

The US National Electrical Code® (NEC) and the Canadian Electrical Code (CEC) permit the use of Division marked equipment in Zones and Zone marked equipment in Divisions. The markings must be suitable for the area classification, gas, and temperature class. This information is clearly defined in the respective codes.

### 3.4 USA

#### 15 Intrinsic Safety; Nonincendive

Certificate: 1053834

Standards: FM Class 3600 – 2011, FM Class 3610 – 2010, FM Class 3611 – 2004, FM Class 3810 – 2005

Markings: IS CL I, DIV 1, GP A, B, C, D when connected per Rosemount drawing 03031-1024, CL I ZONE 0 AEx ia IIC T4; NI CL 1, DIV 2, GP A, B, C, D T5; T4(-20 °C ≤ T<sub>a</sub> ≤ +70 °C) [HART]; T4(-20 °C ≤ T<sub>a</sub> ≤ +60 °C) [Fieldbus]; Type 4x

### 3.5 Canada

#### 16 Intrinsic Safety

Certificate: 1053834

Standards: ANSI/ISA 12.27.01-2003, CSA Std. C22.2 No.142-M1987, CSA Std. C22.2. No.157-92, CSA Std. C22.2 No. 213 - M1987

Markings: Intrinsically Safe Class I, Division 1 Groups A, B, C, D when connected in accordance with Rosemount drawing 03031-1024, Temperature Code T4; Suitable for Class I, Zone 0; Type 4X; Factory Sealed; Single Seal (See drawing 03031-1053)

### 3.6 Europe

#### 11 ATEX Intrinsic Safety

Certificate: BAS97ATEX1089X

Standards: EN 60079-0:2012 + A11:2013, EN 60079-11:2012

Markings: HART:  $\text{Ex} \text{II} 1 \text{G Ex ia IIC T5/T4 Ga, T5}(-20^\circ\text{C} \leq T_a \leq +40^\circ\text{C}),$   
 $\text{T4}(-20^\circ\text{C} \leq T_a \leq +70^\circ\text{C})$   
 Fieldbus:  $\text{Ex} \text{II} 1 \text{G Ex ia IIC Ga T4}(-20^\circ\text{C} \leq T_a \leq +60^\circ\text{C})$

**Table 5. Input Parameters**

Parameter	HART	Fieldbus/PROFIBUS
Voltage $U_i$	30 V	30 V
Current $I_i$	200 mA	300 mA
Power $P_i$	0.9 W	1.3 W
Capacitance $C_i$	0.012 $\mu\text{F}$	0 $\mu\text{F}$
Inductance $L_i$	0 mH	0 mH

**Special Conditions for Safe Use (X):**

1. The apparatus is not capable of withstanding the 500 V insulation test required by clause 6.3.12 of EN60079-11:2012. This must be taken into account when installing the apparatus.
2. The enclosure may be made of aluminum alloy and given a protective polyurethane paint finish; however care should be taken to protect it from impact or abrasion if located in Zone 0.

### 3.7 International

**17 IECEx Intrinsic Safety**

Certificate: IECEx BAS 09.0076X

Standards: IEC 60079-0:2011, IEC 60079-11:2011

Markings: HART:  $\text{Ex ia IIC T5/T4 Ga, T5}(-20^\circ\text{C} \leq T_a \leq +40^\circ\text{C}), \text{T4}(-20^\circ\text{C} \leq T_a \leq +70^\circ\text{C})$   
 Fieldbus:  $\text{Ex ia IIC T4 Ga}(-20^\circ\text{C} \leq T_a \leq +60^\circ\text{C})$

**Table 6. Input Parameters**

Parameter	HART	Fieldbus/PROFIBUS
Voltage $U_i$	30 V	30 V
Current $I_i$	200 mA	300 mA
Power $P_i$	0.9 W	1.3 W
Capacitance $C_i$	0.012 $\mu\text{F}$	0 $\mu\text{F}$
Inductance $L_i$	0 mH	0 mH

**Special Conditions for Safe Use (X):**

1. The apparatus is not capable of withstanding the 500 V insulation test required by clause 6.3.12 of EN60079-11:2012. This must be taken into account when installing the apparatus.
2. The enclosure may be made of aluminum alloy and given a protective polyurethane paint finish; however care should be taken to protect it from impact or abrasion if located in Zone 0.

## 3.8 Additional Certifications

### 3-A®

All Rosemount 3051HT transmitters with the following connections are 3-A approved and labeled:

T32: 1 1/2-in. Tri Clamp

T42: 2-in. Tri Clamp

If process connection B11 is selected, please reference the ordering table of the Rosemount 1199 Diaphragm Seal PDS (00813-0100-4016) for availability of 3-A certifications.

A 3-A certificate of compliance is available by selecting option code QA.

### EHEDG

All Rosemount 3051HT transmitters with the following connections are EHEDG approved and labeled:

T32: 1 1/2-in. Tri Clamp

T42: 2-in. Tri Clamp

If process connection B11 is selected, please reference the ordering table of the Rosemount 1199 Diaphragm Seal PDS (00813-0100-4016) for availability of EHEDG certifications.

An EHEDG certificate of compliance is available by selecting option code QE.

Ensure gasket selected for installation is approved to meet both application and EHEDG certification requirements.

### ASME-BPE

All Rosemount 3051HT Transmitters with option F2 and the following connections are designed to ASME-BPE SF4 standards<sup>(1)</sup>:

T32: 1 1/2-in. Tri Clamp



T42: 2-in. Tri Clam

A self-certified certificate of compliance to ASME-BPE is also available (option QB)

1. Per Clause SD-2.4.4.2 (m), suitability of painted aluminum housings to be determined by end user.



Figure 7. Rosemount 3051HT Declaration of Conformity

## EU Declaration of Conformity

No: RMD 1106 Rev. D

---

We,

**Rosemount, Inc.**  
**8200 Market Boulevard**  
**Chanhasen, MN 55317-9685**  
**USA**

declare under our sole responsibility that the product,

**Rosemount™ 3051HT Pressure Transmitter**

manufactured by,

**Rosemount, Inc.**  
**8200 Market Boulevard**  
**Chanhasen, MN 55317-9685**  
**USA**

to which this declaration relates, is in conformity with the provisions of the European Union Directives, including the latest amendments, as shown in the attached schedule.

Assumption of conformity is based on the application of the harmonized standards and, when applicable or required, a European Union notified body certification, as shown in the attached schedule.



---

(signature)

Vice President of Global Quality

---

(function)

Chris LaPoint

---

(name)

19-July-2017

---

(date of issue)

Page 1 of 3



## EU Declaration of Conformity

No: RMD 1106 Rev. D

### EMC Directive (2014/30/EU)

Harmonized Standards: EN 61326-1:2013, EN 61326-2-3:2013

### RoHS Directive (2011/65/EU) – Effective from 22 July 2017

This product conforms to Directive 2011/65/EU of the European Parliament and of the Council on the restriction of the use of certain hazardous substances in electrical and electronic equipment.

### ATEX Directive (2014/34/EU)

#### **BAS97ATEX1089X - Intrinsic Safety**

Equipment Group II Category 1 G

Ex ia IIC T5/T4 Ga

Harmonized Standards Used:

EN60079-0:2012 + A11:2013, EN60079-11:2012

#### **BAS00ATEX3105X - Type n and Certificate**

Equipment Group II Category 3 G

Ex nA IIC T5 Gc

Harmonized Standards Used:

EN60079-0:2012 + A11:2013, EN60079-15:2010

#### **Baseefa11ATEX0275X - Dust Certificate**

Equipment Group II Category 1 D

Ex ta IIIC T95°C T<sub>500</sub>105°C Da

Harmonized Standards Used:

EN60079-0:2012 + A11:2013, EN60079-31:2014



## EU Declaration of Conformity

No: RMD 1106 Rev. D

### ATEX Notified Body

**SGS Baseefa Limited** [Notified Body Number: 1180]  
Rockhead Business Park  
Staden Lane  
Buxton, Derbyshire  
SK17 9RZ United Kingdom

### ATEX Notified Body for Quality Assurance

**SGS Baseefa Limited** [Notified Body Number: 1180]  
Rockhead Business Park  
Staden Lane  
Buxton, Derbyshire  
SK17 9RZ United Kingdom

含有China RoHS管控物质超过最大浓度限值的部件型号列表 Rosemount 3051HT  
List of Rosemount 3051HT Parts with China RoHS Concentration above MCVs

部件名称 Part Name	有害物质 / Hazardous Substances					
	铅 Lead (Pb)	汞 Mercury (Hg)	镉 Cadmium (Cd)	六价铬 Hexavalent Chromium (Cr +6)	多溴联苯 Polybrominated biphenyls (PBB)	多溴联苯醚 Polybrominated diphenyl ethers (PBDE)
电子组件 Electronics Assembly	X	O	O	O	O	O
壳体组件 Housing Assembly	O	O	O	O	O	O
传感器组件 Sensor Assembly	X	O	O	O	O	O

本表格系依据SJ/T11364的规定而制作。

This table is proposed in accordance with the provision of SJ/T11364.

O: 意为该部件的所有均质材料中该有害物质的含量均低于GB/T 26572所规定的限量要求。

O: Indicate that said hazardous substance in all of the homogeneous materials for this part is below the limit requirement of GB/T 26572.

X: 意为在该部件所使用的所有均质材料里，至少有一类均质材料中该有害物质的含量高于GB/T 26572所规定的限量要求。

X: Indicate that said hazardous substance contained in at least one of the homogeneous materials used for this part is above the limit requirement of GB/T 26572.





**Global Headquarters**

**Emerson Automation Solutions**  
6021 Innovation Blvd.  
Shakopee, MN 55379, USA  
+1 800 999 9307 or +1 952 906 8888  
+1 952 949 7001  
RFQ.RMD-RCC@Emerson.com

**North America Regional Office**

**Emerson Automation Solutions**  
8200 Market Blvd.  
Chanhassen, MN 55317, USA  
+1 800 999 9307 or +1 952 906 8888  
+1 952 949 7001  
RMT-NA.RCCRFQ@Emerson.com

**Latin America Regional Office**

**Emerson Automation Solutions**  
1300 Concord Terrace, Suite 400  
Sunrise, FL 33323, USA  
+1 954 846 5030  
+1 954 846 5121  
RFQ.RMD-RCC@Emerson.com

**Europe Regional Office**

**Emerson Automation Solutions**  
Neuhofstrasse 19a P.O. Box 1046  
CH 6340 Baar  
Switzerland  
+41 (0) 41 768 6111  
+41 (0) 41 768 6300  
RFQ.RMD-RCC@Emerson.com

**Asia Pacific Regional Office**

**Emerson Automation Solutions**  
1 Pandan Crescent  
Singapore 128461  
+65 6777 8211  
+65 6777 0947  
Enquiries@AP.Emerson.com

**Middle East and Africa Regional Office**

**Emerson Automation Solutions**  
Emerson FZE P.O. Box 17033  
Jebel Ali Free Zone - South 2  
Dubai, United Arab Emirates  
+971 4 8118100  
+971 4 8865465  
RFQ.RMTMEA@Emerson.com



Linkedin.com/company/Emerson-Process-Management



Twitter.com/Rosemount\_News



Facebook.com/Rosemount



Youtube.com/user/RosemountMeasurement



Google.com/+RosemountMeasurement

Standard Terms and Conditions of Sale can be found at  
[www.Emerson.com/en-us/pages/Terms-of-Use](http://www.Emerson.com/en-us/pages/Terms-of-Use)

The Emerson logo is a trademark and service mark of Emerson Electric Co.

Rosemount and Rosemount logotype are trademarks of Emerson. NEMA is a registered trademark and service mark of the National Electrical Manufacturers Association.

National Electrical Code is a registered trademark of National Fire Protection Association, Inc.

DTM is a trademark of the FDT Group.

HART is a registered trademark of the FieldComm Group.

3-A is a registered trademark of 3-A Sanitary Standards, Inc.

All other marks are the property of their respective owners.

© 2017 Emerson Process Management. All rights reserved.