

Signet 2744-2747 Differential DryLoc® pH/ORP Electrodes



High Performance



Protected
Bulb

Flat
Glass

The Signet 2744-2747 Differential pH and ORP electrodes are high performance sensors built with the DryLoc® connector, a Ryton® body, and PTFE reference junction to handle the most extreme and harshest of chemical applications.

These differential electrodes use a field-proven 3-electrode differential technique: the pH and reference electrodes are measured against a ground electrode, ensuring a steady and stable signal.

A key feature is the reference electrode, which is housed in a glass half-cell embedded in the reference chamber and is protected from compounds that may contain sulfides (S²⁻) and metals. To ensure long service life, the reference features a refillable electrolyte chamber and a replaceable equitransferant salt bridge, both easily serviced in the field. The patented porous PTFE reference junction resists fouling, clogging and chemical attack.

Other elements of the design are the solution ground, the pH/ORP electrodes, and the temperature element. The solution ground eliminates noisy measurements by draining electrical current away from the reference electrode. The pH/ORP electrodes are designed with a flat or bulb surface, and a temperature device positioned at the tip of the measurement surface for a quick temperature response. Various temperature devices offered include 3 KΩ or Pt1000 RTD.

The electrodes are used with the Signet 2751 Smart Sensor Electronics, which provide a blind 4 to 20 mA output or use the digital (S³L) output to connect the Signet 8900, 9900 or 9950 instruments, and the 0486 Profibus Concentrator. The electrodes can also be used with the 2760 Preamplifier to connect to ProPoint® and ProcessPro® series of pH/ORP instrumentation.

Features

- Differential design for stable measurements in the most aggressive applications
- Long service life even in severe or difficult chemical applications
- Memory chip enabled for access to a wide range of unique features when connected to the Signet 2751 pH/ORP Smart Sensor Electronics
- High performance glass that can withstand high pH caustic media as well as elevated temperature applications
- Ryton (PPS) body for broad range of chemical compatibility
- Watertight DryLoc® connector with foul-proof gold plated contacts*
- Porous PTFE reference junction resists fouling and chemical attack
- Rebuildable reference electrode
- Solution ground
- Temperature sensor (pH)
- Easy sensor replacement using DryLoc electrode connector
- Quick temperature response
- Compatible with all Signet instruments

Applications

- Plating Baths
- Surface Finishing
- Plant Effluent
- Water and Wastewater Treatment
- Scrubbers
- Textile Dye Process
- Harsh Chemical Applications
- Heavy Metal Removal and Recovery
- Toxic Destruction
- Coagulation and Flocculation

See Technical Reference section for assistance in choosing the correct sensor.

*U.S. Patent No.: 6,666,701

Specifications

General		
Compatibility	Signet 2751 and 2760	
Operating Range	2744/2746	0 to 14 pH
	2745/2747	±1500 mV (ORP)
Process Connection	1 in., for use in reducing tees up to 4 in.	
Wetted Materials		
Body	Ryton®	
Reference Junctions	PTFE	
Sensing Surface	pH	Glass membrane
	ORP	Platinum
O-rings	EPDM	
Solution Ground	Carbon graphite	
Max. Temperature/Pressure Rating		
Operating Temperature Range	10 °C to 100 °C	50 °F to 212 °F
Operating Pressure Range	0 to 6.9 bar (0 to 100 psi) @ 10 °C to 65 °C (50 °F to 149 °F)	
	Linearity Derated 6.9 to 4.0 bar (100 to 58 psi) @ 65 °C to 100 °C (149 °F to 212 °F)	
Recommended Storage Temperature		
	0 °C to 50 °C	32 °F to 122 °F
The electrode glass will shatter if shipped or stored at temperatures below 0 °C (32 °F).		
The performance life of the electrode will shorten if stored at temperatures above 50 °C (122 °F).		
Mounting		
In-line/Vertical Mounting	Use sensor 1 in. threads. Sensor must be mounted at least 15 degrees above the horizontal axis.	
Submersible Mounting	Use threads on Model 2751 or 2760; requires ¾ in. NPT or ISO 7/1-R 3/4 male threaded extension.	
Reference	Electrolyte	Buffered equi-transferant salt solution gel
	Element	pH half-cell
Temperature Sensor	pH	3 KΩ, Pt1000 RTD
	ORP	10K ID Resistor
Shipping Weight		
	0.25 kg	0.55 lb
Standards & Approvals		
	Manufactured under ISO 9001, 14001 and OHSAS 18001 for Quality	

Dimensions

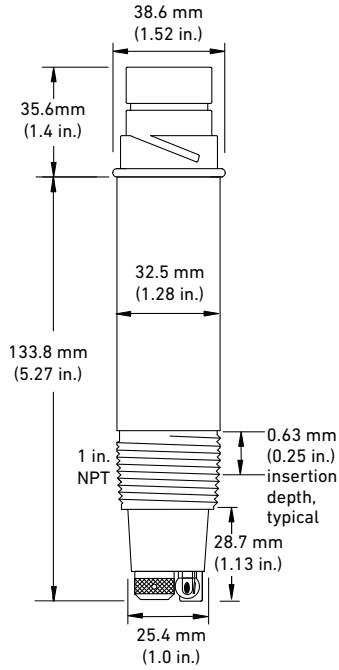

Flat and Bulb versions have the same dimensions

System Overview

Panel Mount	Pipe, Tank, Wall	4 to 20 mA Output	Automation System
<p>Signet Instruments with 2751 Smart Sensor Electronics</p> <ul style="list-style-type: none"> - 8900 - 9900 - 9950 	<p>Signet Instruments with 2751 Smart Sensor Electronics</p> <ul style="list-style-type: none"> - 9900 and Rear Enclosure 	<p>2751 Smart Sensor Electronics with</p> <ul style="list-style-type: none"> - Customer Supplied Chart Recorder - Programmable Logic Controller, or - Programmable Automation Controller 	<p>2751 Smart Sensor Electronics with</p> <ul style="list-style-type: none"> - 0486 Profibus Concentrator and Customer Supplied Programmable Logic Controller or - Programmable Automation Controller

Signet 2744-2747 DryLoc® pH/ORP Electrodes



All sold separately

In-Line Installation - threaded fittings only



Submersible Installation - Customer supplied pipe extension or conduit with 3/4 in. NPT or ISO 7/1-R 3/4 threads*



*Refer to the Signet Submersion Kit brochure (3-0000.707) located on our website for installation suggestions and options.

Electrode Key Features and Benefits

1. Glass encased reference electrode protects the Ag/AgCl (silver/silver chloride) element from reacting with certain chemical compounds that typically leach into the reference chambers. Keeps the pH/ORP reading stable.
2. Large volume reference electrolyte chamber resists dilution over time for a long service life. Chamber is refillable. Holds approximately 30 ml of electrolyte.
3. Salt Bridge serves as a double reference junction and is the first line of defense to keep out process chemicals from the reference electrolyte chamber. It is built with a double porous PTFE reference junction which is highly compatible to chemicals, resists fouling and build-up of dirt.
4. Memory chip enabled for convenient data storage and access (calibration data, operational data, and manufacturing data), electrode health monitoring via glass impedance measurement when used in connection with the 2751 pH/ORP Smart Sensor Electronics.
5. Ryton® body for chemical compatibility to most harsh chemicals. Also able to withstand high temperatures.
6. DryLoc connector with corrosion resistant gold plated pins for quick and easy sensor removal.
7. Capillary TC (temperature sensor) embedded in tip of pH/ORP electrode for quick temperature response.
8. Measuring pH/ORP electrode.
9. Solution Ground electrode eliminates noisy measurements by draining electrical current away from the reference electrode.

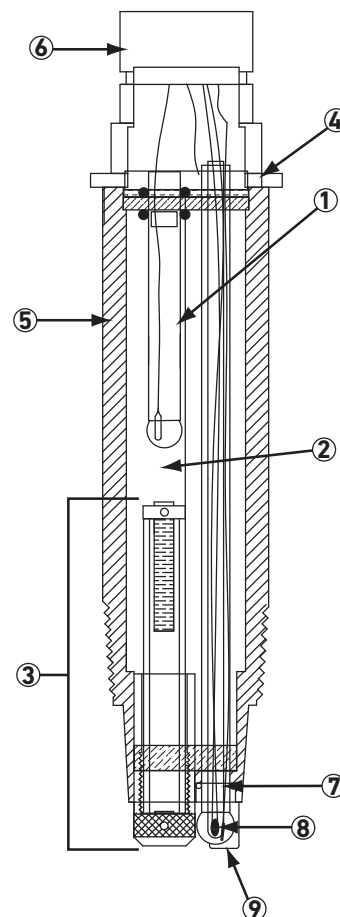

Electrode Cut-Away View

A differential electrode solves many common problems typically experienced by standard pH/ORP electrodes at troublesome measuring points. See the table below to find the common problem, cause and effect, and the differential pH/ORP electrode solution.

If the (Signet Models 272X, 273X or 277X) pH/ORP electrode experiences the following:	The cause and effect of the problem may be:	Use a Differential Electrode to solve the problem because:
<ul style="list-style-type: none"> • Reading slowly drifts over time • Sensor responds slowly 	<ul style="list-style-type: none"> • Chemical attack from Hg^{2+}, Cu^+, Pb^{2+}, ClO_4^- or other compounds which react with or dilute the KCl reference electrolyte. • Reference junction gets clogged from oils, grease, or dirt from the process. 	<ul style="list-style-type: none"> • Salt bridge will slow or stop attack. If attacking ions penetrate the salt bridge and affect the reference, simply refill reference solution. • Readings do not drift due to stable differential reference design, however may require cleaning or replacement of the salt bridge if electrode gets too dirty.
<ul style="list-style-type: none"> • Reading slowly drifts over time • Sensor reading becomes erratic 	<ul style="list-style-type: none"> • Chemical attack of the Ag^+ reference from Br^-, I^-, CN^-, and S_2^- compounds. • Clogged reference and slowed reading from silver compounds forming on the inside of the reference electrode from Ag^+ of reference element reacting and precipitating Ag_2S, $AgBr$, AgI, $AgCN$, or other silver compounds. 	<ul style="list-style-type: none"> • Will not affect electrode due to Ag^+ element protected in glass encased reference electrode. • Will not affect electrode due to Ag^+ element protected in glass encased reference electrode.
<ul style="list-style-type: none"> • Reading suddenly jumps to a new value • Reading unexpectedly changes 	<ul style="list-style-type: none"> • Stray electrical currents in the process liquid; Ag^+ reference element picks up current and shifts reference reading, resulting in shifted pH reading. The Ag^+ element will eventually become totally stripped. Process must be properly grounded or place metal rod close to electrode. 	<ul style="list-style-type: none"> • Will not affect electrode due to Ag^+ element protected in glass encased reference electrode; also, electrode has a built in solution ground, so if there is a stray current, it will not be seen by the electrode.

Temperature/Pressure Graph

Note:

The pressure/temperature graphs are specifically for the Signet sensor. During system design the specifications of all components must be considered. In the case of a metal piping system, a plastic sensor will reduce the system specification.

Ion	Ion name	Ion	Ion name	Compound	Compound name
Br ⁻	Bromide	Hg ²⁺	Mercury	KCl	Potassium chloride
Cu ⁺	Copper iron	ClO ₄ ⁻	Perchlorate	Ag ₂ S	Silver sulfide
CN ⁻	Cyanide	Ag ⁺	Silver	AgBr	Silver bromide
I ⁻	Iodide	S ²⁻	Sulfide	AgI	Silver iodide
Pb ⁺⁺	Lead			AgCN	Silver cyanide

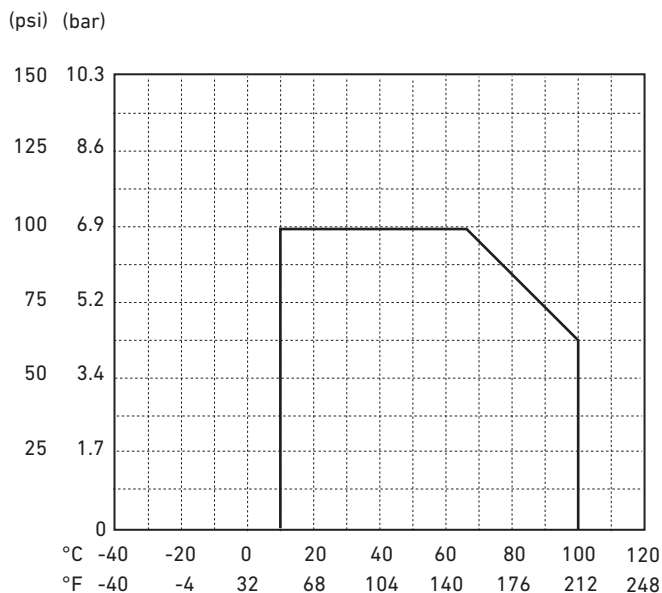

Model 2744-2747

Ordering Notes

- 1) pH and ORP electrodes require connection to model 2751 or 2760.
- 2) Conduit and mounting brackets for submersible installations must always be used (customer supplied).
- 3) Adapters from 1 - 1 1/2 in. are available.
- 4) Use sensor threads for in-line mounting; Model 2751 or 2760 threads for submersible mounting.
- 5) Reference electrode can be rebuilt with replacement electrolyte and salt bridge.

Application Tips

- Use the flat glass electrodes when a self-cleaning feature is desired; especially useful in applications with abrasive chemicals for in-line installations.
- Use bulb protected electrodes for low temperature applications where a fast response is required.
- ORP electrodes are generally used for chemical reaction monitoring, not control.
- Ensure sensor materials are chemically compatible with the process liquid.
- Keep electrode tip wet, avoid air pockets and sediment.

Buffer Solutions

- 3822-7004
- 3822-7007
- 3822-7010

Quinhydrone

3822-7115

The Signet pH buffers are ideal for calibration. The liquid solutions are conveniently packaged in one pint (473 ml) bottles. pH buffer kits in powder pillows are available for mixing fresh solutions with water at the time of use.



All pH buffers are color coded for easy identification; 4.01 pH is red, 7.00 pH is yellow, and 10.00 pH is blue. All pH buffers are traceable to NIST standards. The 4.01 and 7.00 pH buffer solutions can be used to calibrate ORP sensors when saturated with quinhydrone.

Please refer to Wiring, Installation, and Accessories sections for more information.

Ordering Information

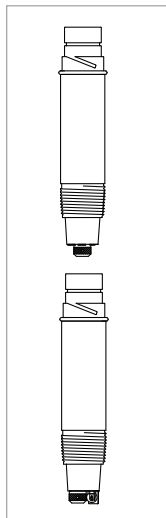

Mfr. Part No.	Code	Tip Design	Temperature Element
pH Differential Electrode			
3-2744-1	159 001 944	Flat	3 KΩ Balco ^{1,2}
3-2744-2	159 001 910	Flat	Pt1000 ¹
3-2746-1	159 001 911	Bulb with protection	3 KΩ Balco ^{1,2}
3-2746-2	159 001 912	Bulb with protection	Pt1000 RTD ¹
ORP Differential Electrode			
3-2745-1	159 001 913	Flat	10 KΩ ID ^{1,2}
3-2747-1	159 001 914	Bulb with protection	10 KΩ ID ^{1,2}

¹ For use with the Multi-Parameter instruments, and Profibus Concentrator when used with the 2751 Smart Sensor Electronics. The 2751 Smart Sensor Electronics has a digital (S²L) output which is used with the Multi-Parameter instruments. It also has a 4 to 20 mA output for connections to PLC's, data recorders, etc.

² The 2760 preamplifier is used for connection directly to ProPoint® and ProcessPro® series pH/ORP instrumentation.

Accessories and Replacement Parts

Mfr. Part No.	Code	Description
1224-0205	159 000 836	O-ring, EPDM
3-2700.395	159 001 605	Calibration kit: includes 3 polypropylene cups, box used as cup stand, 1 pint pH 4.01, 1 pint pH 7.00
3822-7115	159 001 606	20 gm bottle quinhydrone for ORP calibration (must use pH 4.01 and/or pH 7.00 buffer solutions)
3800-4340	159 001 948	Replacement salt bridge in black
3864-0001	159 001 007	Replacement salt bridge in gray
3864-0002	159 001 008	Replacement reference electrolyte solution, 500 ml
2120-0015	159 001 009	CPVC adapter: 1.5 in. MNPT to 1 in. FNPT
2122-0015	159 001 010	PVDF adapter: 1.5 in. MNPT to 1 in. FNPT
3-0700.390	198 864 403	pH buffer kit (1 each 4, 7, 10 pH buffer in powder form, makes 50 ml of each)
3822-7004	159 001 581	pH 4 buffer solution, 1 pint (473 ml) bottle
3822-7007	159 001 582	pH 7 buffer solution, 1 pint (473 ml) bottle
3822-7010	159 001 583	pH 10 buffer solution, 1 pint (473 ml) bottle
3-2759	159 000 762	pH/ORP system tester kit for all pH instruments
3-2759.391	159 000 764	Adapter cable for use with 2751/2760
3800-5000	159 838 107	3.0M KCl storage solution for pH and ORP, 1 pint (473 ml) bottle
3-2700.398	159 001 886	O-ring lubricant kit (5 packs of Super Lube, 1cc each)

3-2744.099 Rev A (12/19)

© Georg Fischer Signet LLC

3401 Aero Jet Avenue, El Monte, CA 91731-2882 U.S.A. • Tel. (626) 571-2770 • Fax (626) 573-2057 • www.gfsignet.com • e-mail: signet.ps@georgfischer.com

Specifications subject to change without notice. All rights reserved. All corporate names and trademarks stated herein are the property of their respective companies.