

GF 2724-2726 pH/ORP Electrodes

General Purpose



Compatible with ALL GF pH/ORP instruments and SmartPro transmitters



The 2724-2726 pH and ORP electrodes are general purpose sensors ideal for a wide range of applications. These feature a patented reference design and uses the unique foul-proof patented DryLoc® connector. The large area PE reference junction and pathway is constructed to increase the total reference effectiveness and ensures long service life.

The DryLoc® connector with corrosion resistant gold plated contacts readily connects the sensor to the mating 2751 pH/ORP Smart Sensor Electronics or the 2760 Preamplifier. The robust PPS threaded sensor body and choice of flat pH, bulb pH, or flat ORP sensing elements allows a broad range of chemical and mechanical compatibility for a wide variety of applications.

There are two optional pH sensing versions available, HF and LC. The HF version is for applications where traces of hydrofluoric acid (2% or less) will attack standard pH glass. The LC version can be used for low conductivity fluids 20 - 100 $\mu\text{S}/\text{cm}$ nominal and below 20 $\mu\text{S}/\text{cm}$ when mounted under controlled conditions.

The quick temperature response is available in either a Pt1000 or 3 K Ω temperature sensor and allows compatibility with all pH/ORP instruments. The 2724-2726 electrodes incorporate $\frac{3}{4}$ inch NPT or ISO 7/1-R 3/4 threads for installing into GF standard pipe-tees. They can also be mounted directly into standard fittings, DN15 to DN100 ($\frac{1}{2}$ to 4 inch).

Features

- Patented reference design for exceptional performance and prolonged life in harsh environments*
- Memory chip enabled for access to a wide range of unique features when connected to the 2751 pH/ORP Smart Sensor Electronics
- PPS body for broad range of chemical compatibility
- Patented DryLoc® connector with gold plated contacts
- Special design allows for installation at any angle, even inverted or horizontal
- $\frac{3}{4}$ " NPT or ISO 7/1-R 3/4 threaded sensors for use with reducing tees DN15 to DN100 ($\frac{1}{2}$ to 4 in.)
- Mounts in GF standard fittings from DN15 to DN100 ($\frac{1}{2}$ to 4 in.)
- Quick temperature response
- Bulb and flat HF resistant glass available for trace HF, in less than 2% concentration applications
- Low conductivity sensor available for liquids down to 20 $\mu\text{S}/\text{cm}$



Applications

- Water & Wastewater Treatment
- Neutralization Systems
- Effluent Monitoring
- Sanitization Systems
- Pool & Spa Control
- Aquatic Animal Life Support Systems
- Process Control
- Cooling Towers

*U.S. Patent Nos.: 6,666,701, 7,799,193 B2, 7,867,371 B2 and 8,211,282 B2

Specifications

General			
Performance	Efficiency	>97% @ 25 °C (77 ° F)	
Operating Range	pH	0 to 14 pH	
	ORP	±2000 mV	
	3-2726-LC	Low conductivity fluids; 20 - 100 µS/cm nominal < 20 µS; flow must be less than 150 ml/min in a properly grounded system	
	3-2724-HF, 3-2726-HF	Hydrofluoric acid resistant glass, pH 6 or below; trace HF ≤2%	
Compatibility			
	2751 Smart Sensor Electronics (for 8900, 9900, 9950, 4 to 20 mA or Profibus Concentrator), 2760 Pre-amplifier		
Temperature Sensor			
	Pt1000 versions	Compatible with 2751 pH/ORP Smart Sensor Electronics for connection to a PLC or to the 8900, 9900 or 9950 instruments	
	3 KΩ Balco versions	Compatible with 2751 pH/ORP Smart Sensor Electronics or with 2760 pH/ORP Pre-amplifier for connection to the 8750 pH/ORP Transmitter	
Process Connection			
	¾ in. NPT	ISO 7/1-R 3/4	Mounts into fittings
Wetted Materials			
	pH	PPS, glass, UHMW PE, FKM	
	ORP	PPS, glass, UHMW PE, FKM, Platinum	
Max. Temperature/Pressure Rating			
Operating Temperature Range*	bulb tip design	0 °C to 85 °C	32 °F to 185 °F
	flat tip design	10 °C to 85 °C	50 °F to 185 °F
Operating Pressure Range		6.8 bar @ 0 to 65 °C (100 psi @ 32 to 150 °F)	
		4 bar @ 65 to 85 °C (58 psi @ 150 to 185 °F)	
*Best performance for 2724-HF, 2726-HF sensors is above 10 °C (50 °F)			
Recommended Storage Temperature			
		0 °C to 50 °C	32 °F to 122 °F
The electrode glass will shatter if shipped or stored at temperature below 0 °C (32 °F)			
The performance life of the electrode will shorten if stored at temperatures above 50 °C (122 °F)			
Mounting			
In-line Mounting	Use the sensor threads		
	Use a standard fitting up to 4 in.		
	Sensor can be mounted at any angle		
Submersible Mounting	Use threads on models 2751 or 2760		
	Requires ¾ inch NPT or ISO 7/1-R 3/4 male threaded liquid tight extension conduit.		
Shipping Weight			
	0.25 kg	0.55 lb	
Standards and Approvals			
	RoHS compliant, China RoHS		
	Manufactured under ISO 9001, ISO 14001 and ISO 45001		

See Temperature and Pressure graphs for more information

Dimensions

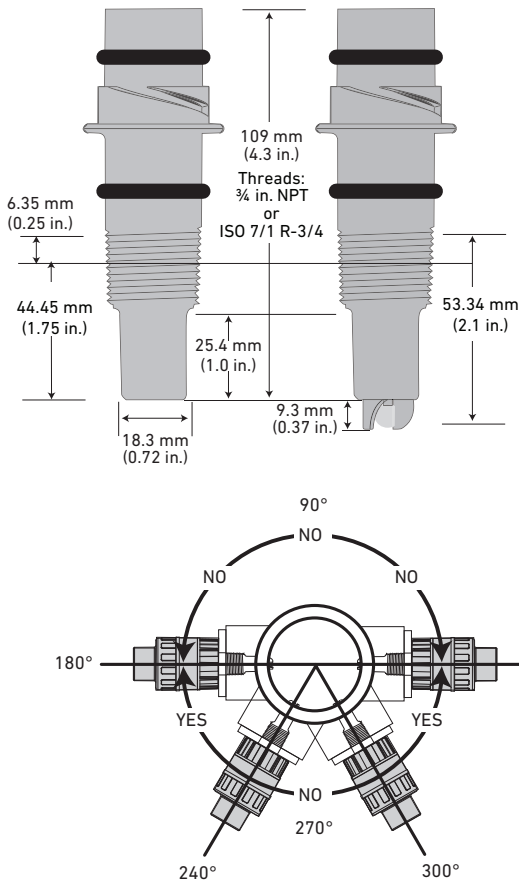

Mounting Angle

Models 2724-2726 may be mounted at any angle without affecting the performance.

*Avoid locations with air pockets and sediment

When mounting in standard threaded fittings the electrode must be mounted horizontally to 60 degrees below horizontal position only.

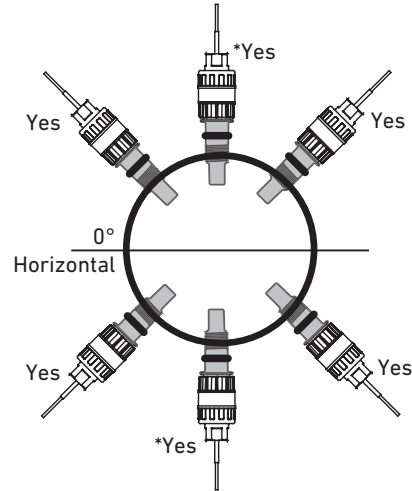

System Overview

Panel Mount	Pipe, Tank, Wall	4 to 20 mA Output	Automation System
GF Instruments with 2751 Smart Sensor Electronics - 8900 - 9900 - 9950	GF Instruments with 2751 Smart Sensor Electronics - 9900 and Rear Enclosure	2751 Smart Sensor Electronics with - Customer Supplied Chart Recorder or Programmable Logic Controller or Programmable Automation Controller	2751 Smart Sensor Electronics with - 0486 Profibus Concentrator and Customer Supplied Programmable Logic Controller or Programmable Automation Controller

**GF 2724-2726
DryLoc® pH/ORP
Electrodes**



All sold separately

In-Line Installation -
GF and threaded 1/2 in to 4 in fittings only

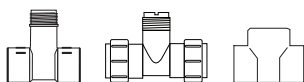

Submersible Installation -
Customer supplied pipe extension or conduit with 3/4 in. NPT or ISO 7/1-R 3/4 threads



Electrode Key Features and Benefits:

1. PPS body for chemical compatibility with most harsh chemicals.
2. Porous UHMW PE (ultra high molecular weight polyethylene) junction resists fouling and build-up.
3. Memory chip enabled for convenient data storage and access (calibration data, operational data, and manufacturing data), electrode health monitoring via glass impedance measurement when used in connection with the 2751 pH/ORP Smart Sensor Electronics.
4. Internal temperature sensor located in the glass stem for a quick temperature response.
5. DryLoc® connector with corrosion resistant gold plated pins for quick and easy sensor removal. Resists moisture and dirt intrusion.
6. Dual-patented reference design with a 406 mm (16 in.) reference pathway for prolonged life in harsh environments. This enables the sensor to last significantly longer than other standard pH/ORP electrodes in most applications.
- 6a. With the patented reference design, the 2726-LC version performs better in low conductivity water between 20 - 100 μS and lasts longer than previous "DI" electrodes.
- 6b. The 2726-LC sensor also performs in applications with extremely low (less than 20 $\mu\text{S}/\text{cm}$) conductivity. Special precautions must be taken to avoid measurement complications. Please note the following.
 - Electrostatic charges (streaming potentials) can cause dramatic offsets in a system with very low conductivity water. To minimize this, sensors should be placed in a well grounded system.
 - To enhance performance, a low flow cell is recommended to provide a steady flow rate (150 ml/minute). Sensors placed in high flow applications will experience noisier readings due to streaming potential.
7. Threads for NPT or ISO process connection into reducing tees
 - Use off-the-shelf GF reducing tees DN20 to DN100 ($\frac{3}{4}$ to 4 in.).
8. Mounts directly into fittings ($\frac{1}{2}$ to 4 in.) for easy sensor retrofitting.
9. Mount submersed into a tank via the 2751 or 2760 back threads.

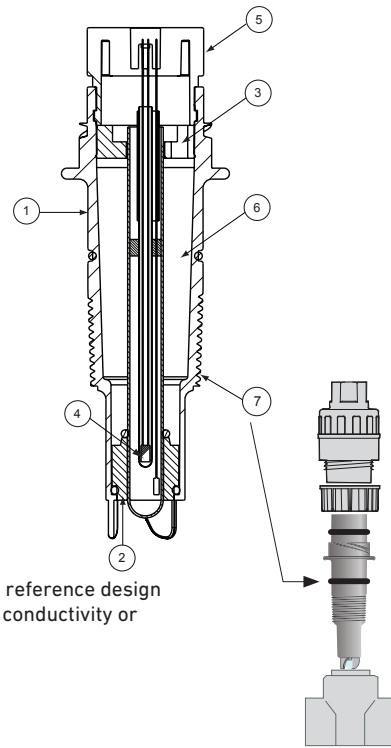

Dual-patented reference design for long life in conductivity or chemicals.

Sensor in threaded reducing tee



⑧ Sensor in fitting

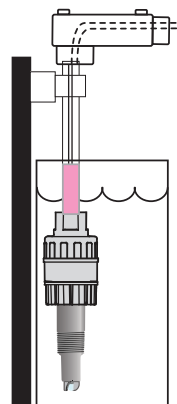

⑨ Sensor submersible installation

Temperature/Pressure Graph

Note:

The pressure/temperature graphs are specifically for the GF sensor. During system design the specifications of all components must be considered. In the case of a metal piping system, a plastic sensor will reduce the system specification.

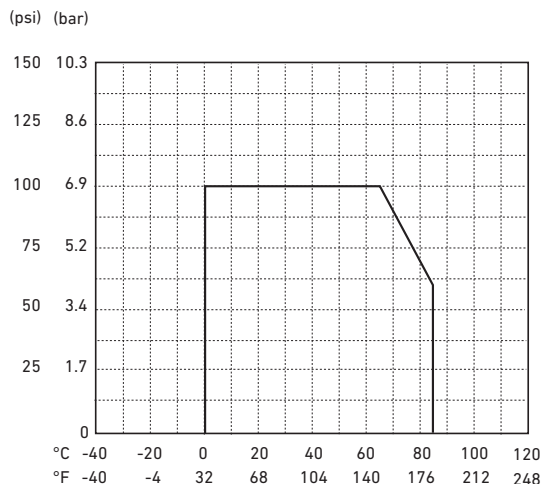

Application Tips

- Use the flat glass electrodes when a self-cleaning feature is desired; especially useful in applications with abrasive chemicals for in-line installations.
- Use bulb protected electrodes for low temperature applications or where fast response is required.
- ORP electrodes are generally used for chemical reaction monitoring, not control.
- Ensure that sensor materials are chemically compatible with the process liquid.
- Keep electrode tip wet, avoid air pockets and sediment.

Model 2724-2726 Ordering Notes

- 1) pH and ORP electrodes require connection to model 2751 pH/ORP Smart Sensor Electronics or 2760 Preamplifier.
- 2) The 2751 "EasyCal" feature recognizes common pH and ORP buffer values of 4, 7 and 10 pH and +87, +264 and +469 mV for ORP.

Buffer Solutions

3822-7004
3822-7007
3822-7010

Quinhydrone

3822-7115



The GF pH buffers are ideal for calibration. The liquid solutions are conveniently packaged in one pint (473 ml) bottles. pH buffer kits in powder pillows are available for mixing fresh solutions with water at the time of use.

All pH buffers are color coded for easy identification; 4.01 pH is red, 7.00 pH is yellow, and 10.00 pH is blue. All pH buffers are traceable to NIST standards. The 4.01 and 7.00 pH buffer solutions can be used to calibrate ORP sensors when saturated with quinhydrone.

Ordering Information

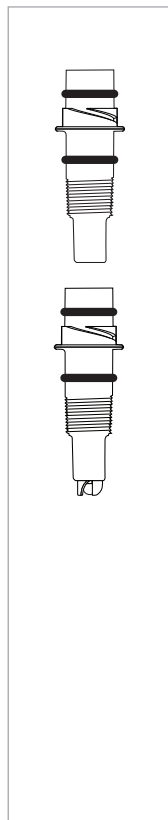

Mfr. Part No.	Code	Tip Design	Process Connection Thread Options
pH Electrodes			
Temperature Element Pt1000; use with 2751 pH/ORP Smart Sensor Electronics* and Profibus Concentrator			
3-2724-00	159 001 545	Flat	¾ in. MNPT, Thread
3-2724-01	159 001 546	Flat	ISO 7/1-R 3/4 Thread
3-2726-00	159 001 553	Bulb	¾ in. MNPT, Thread
3-2726-01	159 001 554	Bulb	ISO 7/1-R 3/4 Thread
3-2726-HF-00	159 001 549	Bulb, HF Resistant ¹	¾ in. MNPT, Thread
3-2726-HF-01	159 001 550	Bulb, HF Resistant ¹	ISO 7/1-R 3/4 Thread
3-2726-LC-00	159 001 557	Bulb, Low Conductivity ²	¾ in. MNPT, Thread
3-2726-LC-01	159 001 558	Bulb, Low Conductivity ²	ISO 7/1-R 3/4 Thread
Temperature Element 3 KΩ Balco; Compatible with both the 2751 pH/ORP Smart Sensor Electronics* and the 2760 Preamplifier**			
3-2724-10	159 001 547	Flat	¾ in. MNPT, Thread
3-2724-11	159 001 548	Flat	ISO 7/1-R 3/4 Thread
3-2724-HF-10	159 001 771	Flat, HF Resistant ¹	3/4 in. NPT, Thread
3-2724-HF-11	159 001 772	Flat, HF Resistant ¹	ISO 7/1-R 3/4 Thread
3-2726-10	159 001 555	Bulb	¾ in. MNPT, Thread
3-2726-11	159 001 556	Bulb	ISO 7/1-R 3/4 Thread
3-2726-HF-10	159 001 551	Bulb HF Resistant ¹	¾ in. MNPT, Thread
3-2726-HF-11	159 001 552	Bulb HF Resistant ¹	ISO 7/1-R 3/4 Thread
3-2726-LC-10	159 001 559	Bulb, Low Conductivity ²	¾ in. MNPT, Thread
3-2726-LC-11	159 001 560	Bulb, Low Conductivity ²	ISO 7/1-R 3/4 Thread
ORP Electrodes; Compatible with both the 2751 pH/ORP Smart Sensor Electronics* and the 2760 Preamplifier**			
3-2725-60	159 001 561	Platinum, Flat, 10 KΩ ID, ¾ in. NPT	¾ in. MNPT, Thread
3-2725-61	159 001 562	Platinum, Flat, 10 KΩ ID, ISO 7/1 R¾	ISO 7/1-R 3/4 Thread

*The 2751 pH/ORP Smart Sensor Electronics has a digital (S³L) output which is used with 8900, 9900 or 9950 instruments, and the Profibus Concentrator.

It also has a 4 to 20 mA output for connections to PLC's, data recorders, etc.

**The 2760 Preamplifier is used for connection directly to 8750 transmitter or other analog transmitters.

¹HF resistant <2%HF

²Low conductivity applications, 20 - 100 μS/cm recommended

Accessories and Replacement Parts

Mfr. Part No.	Code	Description
1220-0021	198 801 000	O-ring, FKM (2 required per sensor)
3-2700.395	159 001 605	Calibration Kit: includes 3 polypropylene cups, box used as cup stand, 1 pint pH 4.01, 1 pint pH 7.00
3822-7115	159 001 606	20 gm Bottle Quinhydrone for ORP Calibration (must use pH 4.01 and/or pH 7.00 buffer solutions)
3-2759	159 000 762	pH/ORP System Tester (adapter cable sold separately)
3-2759.391	159 000 764	2759 DryLoc Adapter Cable (for use with 2751 and 2760)
3-0700.390	198 864 403	pH Buffer Kit (1 each 4, 7, 10 pH buffer in powder form, makes 50 ml of each)
3822-7004	159 001 581	pH 4.01 Buffer Solution, 1 pint (473 ml) bottle
3822-7007	159 001 582	pH 7.00 Buffer Solution, 1 pint (473 ml) bottle
3822-7010	159 001 583	pH 10.00 Buffer Solution, 1 pint (473 ml) bottle
3800-5000	159 838 107	3.0M KCl Storage Solution for pH and ORP, 1 pint (473 ml) bottle
3-2700.397	159 001 870	Protective Cap for pH/ORP Electrodes, 5 pieces
3-2700.398	159 001 886	O-ring Lubricant Kit (5 packs of Super Lube, 1cc each)

3-2724.099 Rev M (02/21)

© Georg Fischer Signet LLC

3401 Aero Jet Avenue, El Monte, CA 91731-2882 U.S.A. • Tel. (626) 571-2770 • Fax (626) 573-2057 • www.gfsignet.com • e-mail: signet.ps@georgfischer.com

Specifications subject to change without notice. All rights reserved. All corporate names and trademarks stated herein are the property of their respective companies.