

Rosemount™ 2160 Wireless Level Switch

Vibrating Fork



WirelessHART™



NOTICE

This guide provides basic guidelines for the Rosemount 2160. It does not provide instructions for detailed configuration, diagnostics, maintenance, service, troubleshooting, or installations. Refer to the Rosemount 2160 [Reference Manual](#) for more instruction. The manual and this guide are also available electronically on Emerson.com/Rosemount.

⚠ WARNING

Failure to follow these installation guidelines could result in death or serious injury.

- The Rosemount 2160 Wireless Vibrating Fork Liquid Level Switch (“level switch”) must be installed, connected, commissioned, operated, and maintained by suitably qualified personnel only, observing any national and local requirements that may apply.
- Use the equipment only as specified. Failure to do so may impair the protection provided by the equipment.

Explosions could result in death or serious injury.

- Installation of the level switch in an explosive environment must be in accordance with the appropriate local, national, and international standards, codes, and practices. Please review the Product Certifications section for any restrictions associated with a safe installation.
- Before connecting a Field Communicator in an explosive atmosphere, ensure the instruments are installed in accordance with intrinsically safe or non-incendive field wiring practices.
- Verify that the operating atmosphere of the level switch is consistent with the appropriate hazardous locations certifications.

External surface may be hot.

- Care must be taken to avoid possible burns.

Process leaks could result in death or serious injury.

- Install and tighten process connectors before applying pressure.
- Do not attempt to loosen or remove process connectors while the level switch is in service.

Electrical shock could cause death or serious injury.

- Avoid contact with the leads and terminals. High voltage that may be present on leads can cause electrical shock.

⚠ WARNING

Operation is subject to the following two conditions:

(1) This device may not cause harmful interference, and (2) this device must accept any interference received, including interference that may cause undesired operation.

This device must be installed to ensure a minimum antenna separation distance of 8 in. (20 cm) from all persons.

The power module may be replaced in a hazardous area. The power module has surface resistivity greater than one gigohm and must be properly installed in the wireless device enclosure. Care must be taken during transportation to and from the point of installation to prevent electrostatic charge build-up.

⚠ CAUTION

Shipping considerations for wireless products

The unit was shipped to you without the power module installed. Please remove the power module prior to shipping the unit.

Each power module contains two “C” size primary lithium batteries. Primary lithium batteries are regulated in transportation by the U.S. Department of Transportation, and are also covered by IATA (International Air Transport Association), ICAO (International Civil Aviation Organization), and ARD (European Ground Transportation of Dangerous Goods). It is the responsibility of the shipper to ensure compliance with these or any other local requirements. Please consult current regulations and requirements before shipping.

1.0 Rosemount 2160 Overview

The Rosemount 2160 Wireless Vibrating Fork Level Switch (“level switch”) uses vibrating short fork technology, and is suitable for virtually all liquid applications.

The level switch is designed to use the principle of a tuning fork. A piezo-electric crystal oscillates the forks at their natural frequency (~ 1400 Hz). Changes to this frequency are continuously monitored. The frequency of the vibrating fork sensor changes depending on the medium in which it is immersed. The denser the liquid, the lower the frequency.

When used as a low level alarm, the liquid in the tank or pipe drains down past the fork, causing a change of natural frequency that is detected by the electronics and switches the output state to a dry condition. When the level switch is used as a high level alarm, the liquid rises in the tank or pipe, making contact with the fork which then causes the output state to switch to a wet condition.

The switch output state, along with other parameters, are regularly transmitted over a secure wireless connection to a Smart Wireless Gateway (“gateway”).

Figure 1. Rosemount 2160 Features

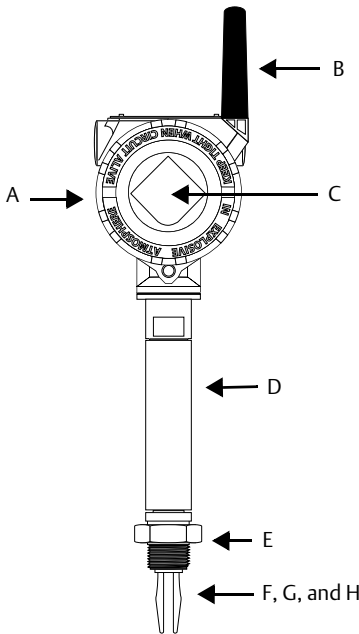

- A. Aluminum housing
- B. Antenna
- C. Optional LCD display
- D. Thermal tube (2160***E only)
- E. Threaded, flanged, or Tri Clamp connections

- F. ‘Fast drip’ fork design
- G. Short fork length or extensions up to 118 in. (3 m)
- H. Wetted materials in 316/316L SST, or Alloy C (UNS N10002) and Alloy C-276 (UNS N10276)

2.0 Before Installation

2.1 General considerations

- The level switch is available as an intrinsically safe version for hazardous area installations. There are ordinary location versions for unclassified, safe areas.
- The weight of the level switch with a heavy flange and extended fork length may exceed 37 lb. (18 kg). A risk assessment is required to be done before carrying, lifting, and installing the level switch.
- Handle the Rosemount 2160 with great care (Figure 2).
- This level switch is designed for open or closed tank and pipe installation. It is weatherproof and protected against the ingress of dust, but must be protected from flooding (Figure 3).

Figure 2. Handling the Rosemount 2160

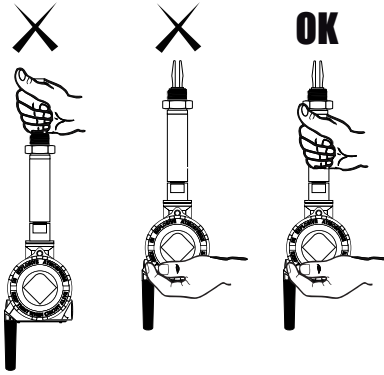
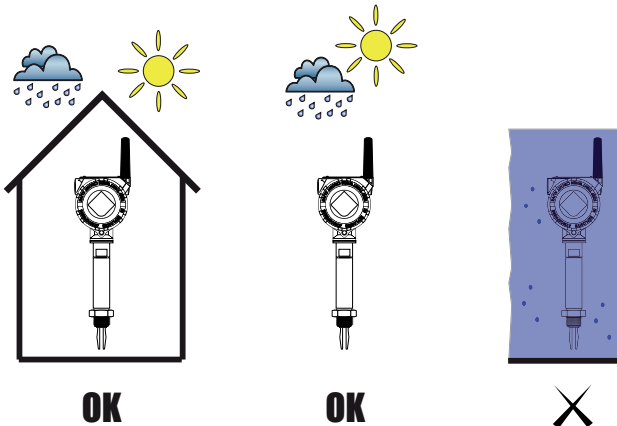

Figure 3. Environmental Considerations



- Mount the switch so that the battery side is accessible. Clearance of $2\frac{3}{8}$ in. (60 mm) is required for cover removal. On the circuit side of the electronics housing, provide 0.75 in. (19 mm) of clearance for units without an LCD display. Three inches of clearance is required for cover removal if an LCD display is installed.
- The housing can be rotated for optimal viewing of the optional LCD display and to get the best antenna position (see “[Housing rotation \(optional\)](#)” on page 5).
- Always ensure a proper seal by installing the electronics housing cover(s) so that metal contacts metal. Use Rosemount O-rings.
- Always ground the housing in accordance with national and local electrical codes. The most effective grounding method for the housing is a direct connection to earth ground with minimal impedance.

2.2 Installation recommendations

- Avoid installing near liquid entering the tank at the fill point.
- Avoid heavy splashing on the forks.
- Avoid installing near heat sources.
- Ensure the fork does not come into contact with a tank/pipe wall or fittings.
- Allow a distance between product build-up and level switch fork ([Figure 4](#)).

Figure 4. Avoid Product Build-up

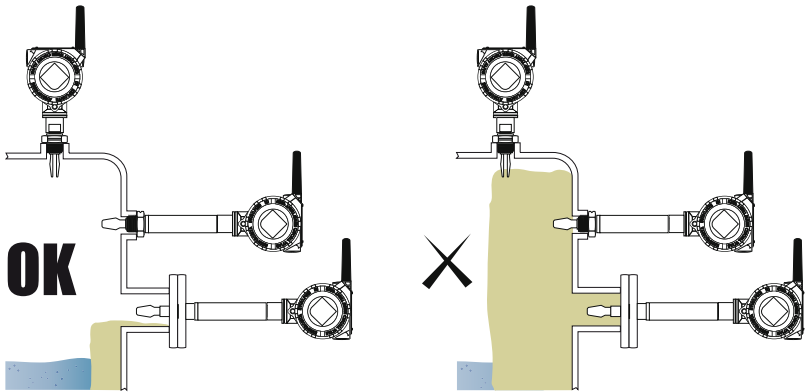

2.3 Housing rotation (optional)

1. Loosen the housing rotation set screw ([Figure 5](#) on page 6).
2. First rotate the housing clockwise to the desired location. If the desired location cannot be achieved due to the thread limit (up to 360°), rotate the housing counter-clockwise to the desired location. Do not over twist.
3. Re-tighten the housing rotation set screw.

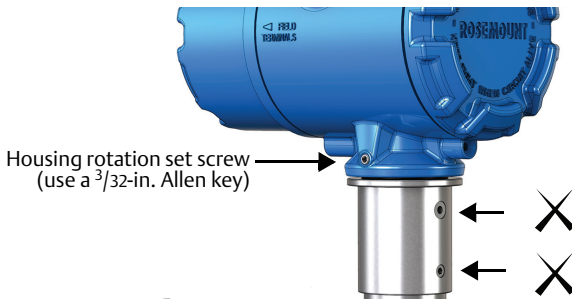
Figure 5. Housing Rotation Set Screw on Rosemount 2160

3.0 Wireless Preparation

3.1 Power-up sequence

The power module should not be installed on any wireless device until the Smart Wireless Gateway (“gateway”) is installed and functioning properly. This level switch uses the black power module. Order model number 701PBKKF.

Wireless devices should also be powered up in order of proximity from the gateway, beginning with the closest. This will result in a simpler and faster network installation. Enable Active Advertising on the gateway to ensure new devices join the network faster.

For more information, see the [Smart Wireless Gateway Manual](#).

3.2 Antenna position

The antenna should be positioned vertically, either straight up or straight down, and should be approximately 3 ft. (1 m) from any large structure or building to allow for clear communication to other devices.

4.0 Physical Installation

1. Install the level switch according to standard installation practices, making sure to correctly align the fork using the alignment notch or groove (Figure 4).
2. Use supports for extended fork lengths greater than 3.2 ft. (1 m). Refer to the Rosemount 2160 [Reference Manual](#) for guidance.
3. Close the housing cover and tighten to safety specification. Always ensure a proper seal so that metal touches metal, but do not over tighten.
4. Insulate the level switch with ROCKWOOL®. Refer to the Rosemount 2160 [Reference Manual](#) for guidance.
5. Position the antenna such that it is vertical, either straight up or down.
6. Plug in the power module after the gateway is installed and functioning (Figure 7 on page 8).

Figure 6. Example Installations

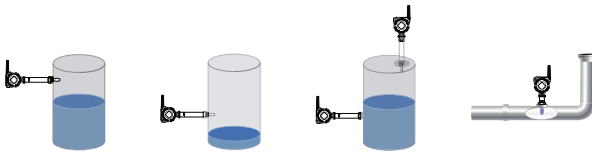

Threaded installation

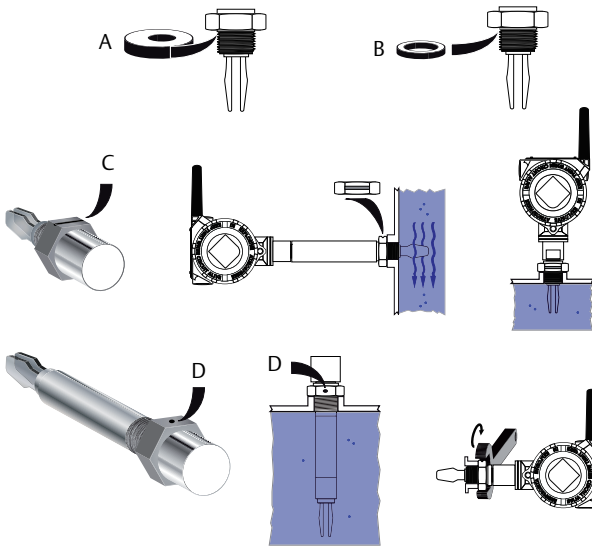

Flanged installation

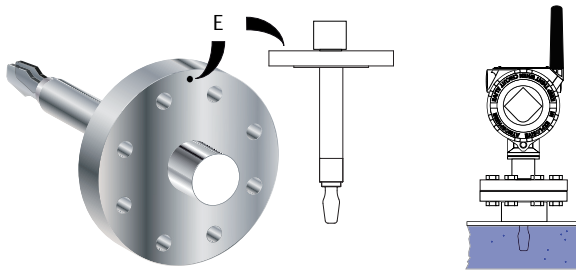

Tri Clamp installation

See the Rosemount 2100 Quick Release Kit [Quick Start Guide](#) for installation instructions.

- A. PTFE for NPT and BSPT (R) thread
- B. Gasket for BSPP (G) thread
- C. Fork alignment notch

- D. Fork alignment notch
- E. Fork alignment notch

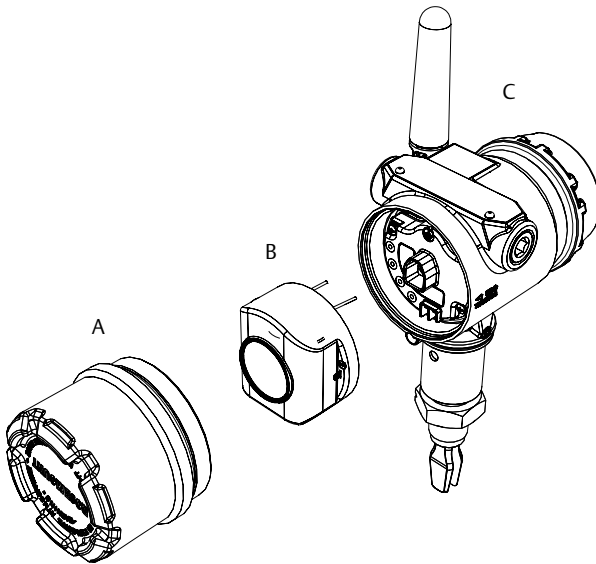
Figure 7. Power Module Installation

- A. Cover
B. Power module
C. Rosemount 2160
-

5.0 Configuration

Note

The Power Module needs to be installed before the Field Communicator can interface with the Rosemount 2160.

5.1 Wireless configuration

To communicate with the Smart Wireless Gateway (“gateway”), and ultimately the host system, the level switch must be configured to communicate with the wireless network. This step is the wireless equivalent of connecting wires from a level switch to the information system.

Using a Field Communicator or AMS Wireless Configurator, enter the **Network ID** and **Join Key** so that they match the Network ID and Join Key of the gateway and other devices in the network. If the Network ID and Join Key do not match that of the gateway, the level switch will not communicate with the network.

The Network ID and Join Key may be obtained from the gateway on the **Setup>Network>Settings** page on the web interface ([Figure 8 on page 9](#)).

Figure 8. Smart Wireless Gateway Screenshot

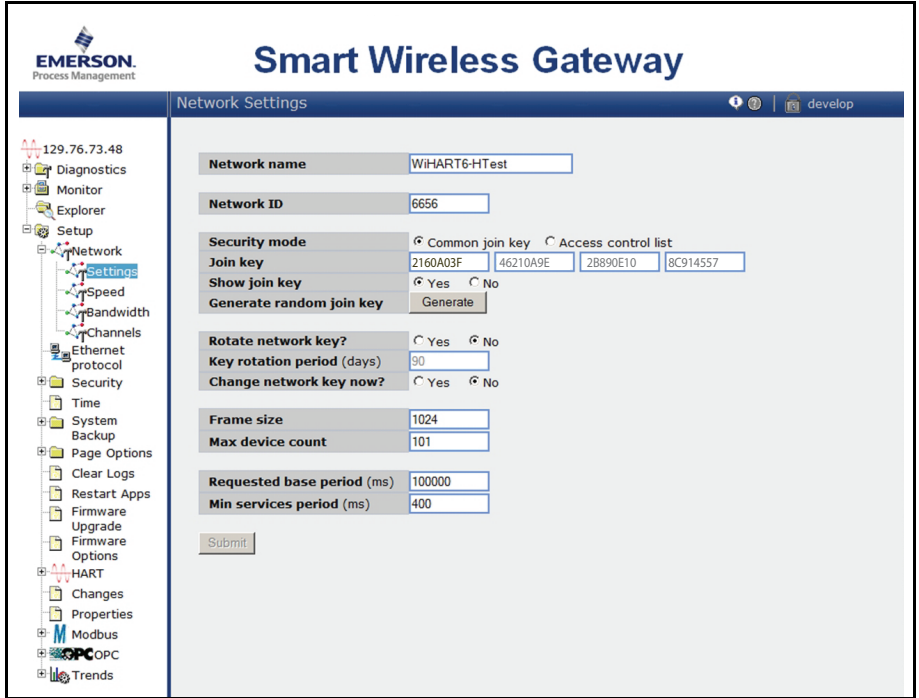

AMS Wireless Configurator

Right-click on the Rosemount 2160 and select **Configure**. When the menu opens, select **Join Device to Network** and follow the method to enter the Network ID and Join Key. When a device joins a network, it appears in the Device Manager (Figure 9).

Figure 9. Device joined Network



Field Communicator

The Network ID and Join Key may be changed in the wireless device by using the Fast Key sequence in Table 1. Set both Network ID and Join Key.

Table 1. Wireless Setup

Function	Key sequence	Menu items
Wireless Setup	2, 2, 1	Network ID and Join Device to Network

Troubleshooting

If the device is not joined to the network after power up, verify the correct configuration of the Network ID and Join Key, and that Active Advertising has been enabled on the gateway. The Network ID and Join Key in the device must match the Network ID and Join Key of the gateway.

5.2 Squawk feature

The “Squawk” feature is available to visually locate an individual Rosemount 2160 amongst multiple networked Rosemount 2160 devices.

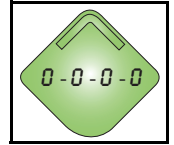

Note

The “Squawk” feature requires the Rosemount 2160 to have the optional LCD meter fitted.

AMS Device Manager instructions

1. From the AMS Device Manager, select the **Tag** of a Rosemount 2160 to be located.
2. Select **Service Tools** and then select **Maintenance**.
3. Select **Routine Maintenance**.
4. Select **Locate Device** and then **Next** to activate Squawk.
5. Look for the pattern **0-0-0-0** on the LCD of the located ‘squawking’ Rosemount 2160.
6. To de-activate Squawk, select **Next**, **Cancel**, **Next**, and finally **Finish**.

Field Communicator instructions

1. From the Home screen, select **3: Service Tools**.
2. Select **5: Maintenance** and then select **4: Routine Maintenance**.
3. Select **1: Locate Device** and follow on-screen instructions to activate Squawk.
4. Look for the pattern **0-0-0-0** on the LCD of the located ‘squawking’ Rosemount 2160.
5. To de-activate Squawk, exit the feature.

Note

It can take up to 60 seconds for the Rosemount 2160 to return to normal operations.

5.3 Basic setup

Use Fast Key sequence 2, 1 to see the guided setup options, or alternatively use this section to do the basic setup manually.

Wireless update rate

This is the interval between data transmission to a gateway, and is in the range 1 second to 60 minutes. (The LCD updates at each wireless update).

How to change or view the update rate

1. From the Home screen, select **2: Configure**.
2. Select **2: Guided Setup**.
3. Select **3: Configure Update Rate**.

Note

If you do not see Configure Update Rate, use Fast Key sequence 2, 2, 1, 3, 1, 5 and disable **Advanced Broadcasting** first.

Operation mode

The Rosemount 2160 has three operation modes:

- “Standard” – Default operation mode with no fault detection.
A 0 Hz sensor frequency represents a wet condition, and not a fault.
PV Status indicates “Valid”.
- “Enhanced (Fault=WET)” – Output state is forced to wet when a fault is detected.
PV Status indicates “Fault”
- “Enhanced (Fault=DRY)” – Output state is forced to dry when a fault is detected.
PV Status indicates “Fault”

How to change or view the operation mode

1. From the Home screen, select **2: Configure**.
2. Select **2: Manual Setup**.
3. Select **2: Operation**.
4. Select **1: Application**.
5. Select **1: Operation Mode**.

Note

See the Rosemount 2160 [Reference Manual](#) for further information about the modes.

Sensor output delay

When the level switch detects a change in process conditions from wet-to-dry or dry-to-wet, the Sensor Output Delay parameter causes a delay of up to 3600 seconds before a new process condition is indicated in the process variables.

How to change or view the sensor output delay

1. From the Home screen, select **2: Configure**.
2. Select **2: Manual Setup**.
3. Select **2: Operation**.
4. Select **1: Application**.
5. Select **2: Sensor Output Delay**.

Media density

The frequency of the vibrating fork sensor can be affected by the process liquid density. Use Media Density to select one of the following options:

- Normal – Select when the liquid specific gravity is between 0.7 and 2.0
- Low – Select when the liquid specific gravity is less than 0.7
- High – Select when the liquid specific gravity is greater than 2.0

How to change or view the media density

1. From the Home screen, select **2: Configure**.
2. Select **2: Manual Setup**.
3. Select **2: Operation**.
4. Select **1: Application**.
5. Select **3: Media Density**.

5.4 Output

Variables

How to view the Variables menu

1. From the Home screen, select **3: Service Tools**.
2. Select **2: Variables**.

The variable menu displays the following important variables:

- PV – level switch output state of 0.0 (dry) or 1.0 (wet)
- PV Status – e.g. good, bad, manual/fixated, or poor accuracy
- Sensor Frequency – the frequency of the vibrating fork
- Electronics Temperature – the temperature inside the level switch housing

6.0 Verify Operation

There are four ways to verify operation: using the local display (LCD), using the Field Communicator, using the Smart Wireless Gateway’s integrated web interface, or by using AMS Wireless Configurator.

6.1 Local display (LCD)

During normal operation, the LCD should display the PV value at update rate intervals of up to 1 minute (see picture, right). Press the Diagnostic button to display the TAG, Device ID, Network ID, Network Join Status and Device Status screens. Refer to the Rosemount 2160 [Reference Manual](#) for error codes and other messages.



6.2 Field Communicator

To communicate with a Field Communicator, power the Rosemount 2160 by connecting the power module and connect the Field Communicator (Figure 10). A Rosemount 2160 DD (Device Description) is also required for HART® wireless communication. To obtain the latest DD, visit the [Emerson™ Easy Upgrade Site](#).

Table 2. Communications Fast Key Sequence

Function	Key sequence	Menu items
Communications	3, 4	Join Status, Communication Status, Join Mode, Number of Available Neighbors, Number of Advertisements Heard, Number of Join Attempts

Figure 10. Field Communicator Connections

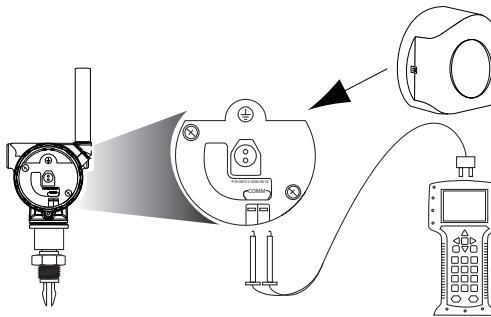

6.3 Smart wireless gateway

Navigate to the Explorer>Status page using the gateway’s integrated web interface. This page shows whether the device has joined the network and if it is communicating properly. It may take several minutes for the device to join the network.

7.0 Product Certifications

7.1 European Union directive information

The EC declaration of conformity certificate is currently not available for the Rosemount 2160. Please check the Rosemount 2160 [web page](#) for updates.

7.2 Telecommunication compliance

All wireless devices require certification to ensure that they adhere to regulations regarding the use of the RF spectrum. Nearly every country requires this type of product certification. Emerson is working with governmental agencies around the world to supply fully compliant products and remove the risk of violating country directives or laws governing wireless device usage.

7.3 FCC and IC

Operation is subject to the following two conditions: (1) This device may not cause harmful interference, and (2) this device must accept any interference received, including interference that may cause undesired operation.

This device must be installed to ensure a minimum antenna separation distance of 8 in. (20 cm) from all persons.

7.4 Ordinary location certification

Korean Testing Laboratory (KTL), KCC mark for ordinary locations use

GP EMC certificate: KCC-REM-ERN-RMDSWIT2160XXX

7.5 Canadian Registration Number

CRN 0F04227.2C

Note

Rosemount 2160 CSA-approved vibrating fork level switch model 2160****S*****16***** when configured with 316/316L stainless steel (1.4401/1.4404) wetted parts and either NPT threaded process or 2-in. to 8-in. ASME B16.5 flanged process connections meets the requirements of CRN.

7.6 Hazardous locations certificates

North American and Canadian approvals

Factory Mutual (FM) approvals

I5 Project ID: 3036541

FM Intrinsically Safe, Non-incendive, and Dust Ignition-proof
Intrinsically Safe for Class I/II/III, Division 1, Groups A, B, C, D, E, F, and G.

Zone Marking: Class I, Zone 0, AEx ia IIC

Temperature Codes T4 ($T_a = -50$ to 70 °C)

Non-incendive for Class I, Division 2, Groups A, B, C, and D

Dust Ignition-proof for Class I/III, Division 1, Groups E, F, and G

Ambient temperature limits: -50 to 70 °C

For use with Emerson's SmartPower option 701PBKCF

Enclosure Type 4X / IP66

Specific condition of safe use

1. Warning – Potential Electrostatic Charging Hazard – The enclosure is partially constructed from plastic. To prevent the risk of electrostatic sparking, use only a damp cloth to clean the plastic surfaces.

Canadian Standards Association (CSA) approval

- 16** Certificate Number: 06 CSA 1786345
 CSA Intrinsically Safe
 Intrinsically Safe for Class I, Division 1, Groups A, B, C, and D
 Temp Code T3C
 Intrinsically Safe when installed in accordance with Rosemount drawing 71097/1271
 For use with Emerson's SmartPower option 701PBKKF
 Enclosure Type 4X / IP66
 Single Seal

International approvals**National Supervision and Inspection Centre (NEPSI) approval**

- 13** NEPSI Intrinsic Safety
 Certificate: GYJ101138X
 Ex ia IIC T5-T2
 (See "NEPSI conditions for safe use (X)" on page 16)

International Electrotechnical Commission (IEC) approval

- 17** IECEx Intrinsic Safety
 Certificate Number: IECEx BAS 09.0123X
 Ex ia IIC T5...T2 Ga
 IP66
 (See "IECEx conditions for safe use (X)" on page 16)

Technical Regulation Customs Union (EAC) approval

- IM** Certificate: RU C-GB.AB72.B.00916
 Intrinsic Safety (NAMUR and 8/16 mA electronics only)
 Markings:
 0Exia IIC T5 Ga X (-50 °C ≤ Ta ≤ +40 °C);
 0Exia IIC T4...T2 Ga X (-50 °C ≤ Ta ≤ +80 °C)
 See certificate for special conditions for safe use (X).

Ukrainian state system of certification of products (UkrSEPRO) approval

- IM** Certificate: 3043, UA.TR.047.C.0625-15
 0Exia IIC T5 X (-50 °C ≤ Ta ≤ +40 °C);
 0Exia IIC T4...T2 X (-50 °C ≤ Ta ≤ +80 °C)
 See certificate for special conditions for safe use (X).

KTL/KOSHA approval

- IP** Certificate: 13-KB4BO-0213X
 Ex ia IIC T5...T2
 Ta (see table in the certificate).

NEPSI conditions for safe use (X)

1. Symbol “X” is used to denote specific conditions of use:
 - a. Model 648 WTT or Model 3051S WPT type battery pack provided by the manufacturer should be used
 - b. The surface resistivity of the antenna is greater than 1 gigaohm. To avoid electrostatic charge build-up, it must not be rubbed or cleaned with solvents or a dry cloth
 - c. The enclosure is made of aluminum alloy and given a protective epoxy coating. Care should be taken to protect it from impact or abrasion if located in a Zone 0.
 - d. NEPSI temperature chart

T Code	Ambient temperature (T _a)	Process temperature (T _p)
T5	-50 °C ≤ T _a ≤ +40 °C	-70 °C ≤ T _p ≤ +80 °C
T4	-50 °C ≤ T _a ≤ +80 °C	-70 °C ≤ T _p ≤ +115 °C
T3	-50 °C ≤ T _a ≤ +80 °C	-70 °C ≤ T _p ≤ +185 °C
T2	-50 °C ≤ T _a ≤ +80 °C	-70 °C ≤ T _p ≤ +260 °C

IECEx conditions for safe use (X)

Model numbers covered:

2160X**S*****I7***** , and 2160X**E*****I7*****

(“*” indicates options in construction, function and materials).

1. The Rosemount 2160 may be used in a hazardous area with flammable gases and vapors with apparatus groups IIC, IIB and IIA, and temperature classes T1 to T5. The temperature class of the installation will be determined from the higher of the process or ambient temperature.
2. It is a special condition of the certification that the temperature of the electronics housing is in the range of -50 °C to 70 °C. It must not be used outside this range. It will be necessary to limit the external ambient temperature if the process temperature is high. (See “[Technical data](#)” on page 17).
3. Suitably trained personnel shall carry out installation in accordance with the applicable code of practice.
4. The user should not repair this equipment.
5. If equipment is likely to come into contact with aggressive substances, it is the user’s responsibility to take suitable precautions that prevent it from being adversely affected, thus ensuring the type of protection is not compromised.
 Aggressive substances: e.g. acidic liquids or gases that may attack metals or solvents that may affect polymeric materials
 Suitable precautions: e.g. regular checks as part of routine inspections or establishing from a material’s data sheet that it is resistant to specific chemicals
6. Special conditions of use
 - a. The user is to ensure the ambient air temperature (T_a) and the process temperature (T_p) are within the range detailed above for the T class of the specific flammable gases or vapors present.
 - b. The surface resistivity of the antenna is greater than 1 gigaohm. To avoid electrostatic charge build-up, it must not be rubbed or cleaned with solvents or a dry cloth.

- c. The Rosemount 2160 enclosure is made of aluminum alloy and given a protective epoxy coating; however, care should be taken to protect it from impact or abrasion if located in an area where Equipment Protection Level Ga is required (Zone 0 locations).
- 7. Technical data
 - a. Coding: Ex ia IIC T5...T2 Ga
 - b. Temperature:

2160X**S*****I7*****

Temperature classes	Maximum ambient air temperature (T _a)	Maximum process temperature (T _p)
T5,T4,T3,T2,T1	40 °C	80 °C
T4,T3,T2,T1	70 °C	100 °C
T4,T3,T2,T1	60 °C	115 °C
T3, T2,T1	50 °C	150 °C

Minimum ambient air temperature (T_a) = -40 °C

Minimum process temperature (T_p) = -40 °C

2160X**E*****I7*****

Temperature classes	Maximum ambient air temperature (T _a)	Maximum process temperature (T _p)
T5,T4,T3,T2,T1	40 °C	80 °C
T4,T3,T2,T1	70 °C	115 °C
T3,T2,T1	65 °C	185 °C
T2,T1	60 °C	260 °C

Minimum ambient air temperature (T_a) = -50 °C

Minimum process temperature (T_p) = -70 °C

- c. Materials: Refer to the Rosemount 2160 [Reference Manual](#).
- d. Year of manufacture: printed on the product label.

含有China RoHS管控物质超过最大浓度限值的部件型号列表 Rosemount 2160
List of Rosemount 2160 Parts with China RoHS Concentration above MCVs

部件名称 Part Name	有害物质 / Hazardous Substances					
	铅 Lead (Pb)	汞 Mercury (Hg)	镉 Cadmium (Cd)	六价铬 Hexavalent Chromium (Cr +6)	多溴联苯 Polybrominated biphenyls (PBB)	多溴联苯醚 Polybrominated diphenyl ethers (PBDE)
电子组件 Electronics Assembly	X	O	O	O	O	O
壳体组件 Housing Assembly	O	O	O	X	O	O
传感器组件 Sensor Assembly	X	O	O	O	O	O

本表格系依据SJ/T11364的规定而制作。

This table is proposed in accordance with the provision of SJ/T11364.

O: 意为该部件的所有均质材料中该有害物质的含量均低于GB/T 26572所规定的限量要求。

O: Indicate that said hazardous substance in all of the homogeneous materials for this part is below the limit requirement of GB/T 26572.

X: 意为在该部件所使用的所有均质材料里，至少有一类均质材料中该有害物质的含量高于GB/T 26572所规定的限量要求。

X: Indicate that said hazardous substance contained in at least one of the homogeneous materials used for this part is above the limit requirement of GB/T 26572.



Global Headquarters

Emerson Automation Solutions
6021 Innovation Blvd.
Shakopee, MN 55379, USA
+1 800 999 9307 or +1 952 906 8888
+1 952 949 7001
RFQ.RMD-RCC@Emerson.com

North America Regional Office

Emerson Automation Solutions
8200 Market Blvd.
Chanhassen, MN 55317, USA
+1 800 999 9307 or +1 952 906 8888
+1 952 949 7001
RMT-NA.RCCRFQ@Emerson.com

Latin America Regional Office

Emerson Automation Solutions
1300 Concord Terrace, Suite 400
Sunrise, FL 33323, USA
+1 954 846 5030
+1 954 846 5121
RFQ.RMD-RCC@Emerson.com

Europe Regional Office

Emerson Automation Solutions
Neuhofstrasse 19a P.O. Box 1046
CH 6340 Baar
Switzerland
+41 (0) 41 768 6111
+41 (0) 41 768 6300
RFQ.RMD-RCC@Emerson.com

Asia Pacific Regional Office

Emerson Automation Solutions
1 Pandan Crescent
Singapore 128461
+65 6777 8211
+65 6777 0947
Enquiries@AP.Emerson.com

Middle East and Africa Regional Office

Emerson Automation Solutions
Emerson FZE P.O. Box 17033
Jebel Ali Free Zone - South 2
Dubai, United Arab Emirates
+971 4 8118100
+971 4 8865465
RFQ.RMTMEA@Emerson.com



[Linkedin.com/company/Emerson-Automation-Solutions](https://www.linkedin.com/company/Emerson-Automation-Solutions)



[Twitter.com/Rosemount_News](https://twitter.com/Rosemount_News)



[Facebook.com/Rosemount](https://www.facebook.com/Rosemount)



[Youtube.com/user/RosemountMeasurement](https://www.youtube.com/user/RosemountMeasurement)



[Google.com/+RosemountMeasurement](https://www.google.com/+RosemountMeasurement)

Standard Terms and Conditions of Sale can be found on the www.Emerson.com/en-us/Terms-of-Use.
The Emerson logo is a trademark and service mark of Emerson Electric Co.
Rosemount and Rosemount logotype are trademarks of Emerson.
ROCKWOOL is a registered trademark of ROCKWOOL International A/S and/or its affiliates.
WirelessHART and HART are registered trademarks of the FieldComm Group.
All other marks are the property of their respective owners.
© 2017 Emerson. All rights reserved.