

Rosemount 2160 Wireless

Vibrating Fork Liquid Level Switch



Wireless**HART**

ROSEMOUNT

www.rosemount.com



EMERSON
Process Management

Rosemount 2160 Wireless Vibrating Fork Liquid Level Switch

Rosemount 2160 Hardware Revision	2
HART® Device Revision	2
Field Communicator Field Device	Dev v1, DD v2

NOTICE

Read this manual before working with the product. For personal and system safety, and for optimum product performance, make sure you thoroughly understand the contents before installing, using, or maintaining this product.

For technical assistance, contacts are listed below:

Customer Central

Technical support, quoting, and order-related questions.

United States: 1 800 999 9307 (7:00 am to 7:00 pm CST)

Asia Pacific: 65 777 8211

Europe/ Middle East/ Africa: 49 (8153) 9390

North American Response Center

Equipment service needs.

1 800 654 7768 (24 hours—includes Canada)

Outside of these areas, contact your local Emerson Process Management representative.

⚠ CAUTION

The products described in this document are NOT designed for nuclear-qualified applications.

Using non-nuclear qualified products in applications that require nuclear-qualified hardware or products may cause inaccurate readings.

For information on Rosemount nuclear-qualified products, contact an Emerson Process Management Sales Representative.

⚠ WARNING

Replacement equipment or spare parts not approved by Emerson for use as spare parts could reduce the capabilities of the 2160, and may render the instrument dangerous.

- Use spare parts supplied or sold by Emerson

⚠ WARNING

Failure to follow these installation guidelines could result in death or serious injury

- The Rosemount 2160 is a *wireless liquid level switch*. It must be installed, connected, commissioned, operated, and maintained by suitably qualified personnel only, observing any national and local requirements that may apply
- Use the equipment only as specified in this manual. Failure to do so may impair the protection provided by the equipment

Explosions could result in death or serious injury

- Installation of the 2160 in a hazardous environment must be in accordance with the appropriate local, national, and international standards, codes, and practices. Please review the approvals section of the 2160 Reference Manual for any restrictions associated with an installation
- Before connecting a Field Communicator in an explosive atmosphere, ensure the installation is in accordance with intrinsically safe or non-incendive field wiring practices
- Verify that the operating atmosphere of the level switch is consistent with the appropriate hazardous locations certifications

External Surface may be hot

- Care must be taken to avoid possible burns

Process leaks could result in death or serious injury

- Install and tighten process connectors before applying pressure
- Do not attempt to loosen or remove process connectors while the 2160 is in service

Electrical shock could cause death or serious injury

- If the liquid level switch is installed in a high voltage environment and a fault condition or installation error occurs, high voltage may be present on leads and terminals
- Use extreme caution when making contact with the leads and terminals
- Make sure that power to the 2160 is off while making connections

Operation is subject to the following two conditions: (1) This device may not cause harmful interference, and (2) this device must accept any interference received, including interference that may cause undesired operation.

NOTICE

Shipping considerations for wireless products:

The unit was shipped to you without the Black Power Module installed. Please remove the power module prior to shipping.

Each power module contains two "C" size primary lithium batteries. These batteries are regulated in transportation by the U. S. Department of Transportation, and are also covered by IATA (International Air Transport Association), ICAO (International Civil Aviation Organization), and ARD (European Ground Transportation of Dangerous Goods). It is the responsibility of the shipper to ensure compliance with these or any other local requirements. Please consult current regulations and requirements before shipping.

The power module with the wireless unit contains two "C" size primary lithium/thionyl chloride batteries. Each battery contains approximately 2.5 grams of lithium, for a total of 5 grams in each pack. Under normal conditions, the battery materials are self-contained and are not reactive as long as the batteries and the pack integrity are maintained. Care should be taken to prevent thermal, electrical or mechanical damage. Contacts should be protected to prevent premature discharge.

Battery hazards remain when cells are discharged.

Batteries should be stored in a clean and dry area. For maximum battery life, storage temperature should not exceed 86 °F (30 °C).

Table Of Contents

SECTION 1 OVERVIEW

Safety Messages	1-1
Warnings	1-1
Using This Manual	1-2
Definitions And Abbreviations	1-2
Models Covered	1-2
About the 2160	1-3
Switch Overview	1-3
Measurement Principle	1-4
Short Fork Technology	1-4
Special Features	1-4
Rosemount 2160 Application Examples	1-5
Extended Fork Supports	1-6
Switchpoint	1-7
Service Support	1-9
Product Recycling/Disposal	1-9

SECTION 2 CONFIGURATION

Safety Messages	2-1
Warnings	2-1
Overview	2-2
Required Bench Top Configuration	2-2
Squawk Feature	2-2
AMS Wireless Configurator	2-2
Field Communicator	2-2
Field Communicator	2-4
Menu Tree	2-4
Device Network Configuration	2-7
Join to Network	2-7
Configure Update Rate	2-7
Operation Mode	2-7
Remove Black Power Module	2-7
Review Configuration Data	2-8
Review Device Identification Information	2-8
Review Radio Information	2-8
Check Output	2-9
Variables	2-9
Basic Setup	2-9
Temperature Units	2-9
Operation Mode	2-9
Sensor Output Delay	2-10
Media Density	2-10
Write Protect	2-10
Data Logging	2-10
LCD Display	2-11
LCD Display Configuration	2-11
Detailed Setup	2-12
Configure Alerts	2-12
Sensor Stabilization Time	2-13
Measurement Time	2-13
Allowable Change In Dry Fork Frequency	2-13

Sensor Fault Delay	2-14
Power Mode	2-14
Power Source	2-14
Diagnostics and Service	2-15
Load User Defaults	2-15
Join Status	2-16
Communication Status	2-16
Join Mode	2-16
Available Neighbors	2-17
Advertisements	2-17
Join Attempts	2-17
Sensor Frequency	2-17
Temperature Compensation	2-18
Uncompensated Frequency	2-18
Sensor State	2-18
Dry Fork Frequency / Switch Points	2-19
Sensor State	2-19
Counters	2-20
Timers	2-21
Calibration	2-21
Dry Fork Frequency	2-21
Sensor Frequency	2-21
Calibrate Dry Fork	2-22
Sensor Calibration Status	2-22
Calibration Count	2-22
Reset Calibration	2-22
Simulation	2-23
Sensor Output	2-23
Fork Frequency	2-23
Advanced Functions for HART Protocol	2-24
Saving, Recalling, and Cloning Configuration Data	2-24

SECTION 3 INSTALLATION

Safety Messages	3-1
Warnings	3-1
Considerations	3-2
General Considerations	3-2
Wireless Considerations	3-2
Environmental Considerations	3-2
Installation Considerations	3-3
Installation Procedures	3-6
Battery Installation	3-6
Installing the LCD Display	3-7
Mechanical	3-8
Correct Fork Alignment	3-9
Tightening the 2160	3-11
Insulation (2160***E Only)	3-12
Operations	3-12

**SECTION 4
COMMISSIONING**

Safety Messages 4-1
 Warnings 4-1
Verify Operation 4-2
 Troubleshooting 4-2
 Local Display 4-2
 Field Communicator 4-2
 Smart Wireless Gateway 4-3
 AMS Wireless Configurator 4-4
How to Use Squawk 4-4

**SECTION 5
OPERATION AND
MAINTENANCE**

Safety Messages 5-1
 Warnings 5-1
Inspection 5-2
Maintenance 5-2
LCD Screen Messages 5-3
 Startup Screen Sequence 5-3
 Diagnostic Button Screen Sequence 5-4
 Network Diagnostic Status Screens 5-5
 Device Diagnostic Screens 5-7
Troubleshooting 5-10
Power Module Replacement 5-10

**APPENDIX A
SPECIFICATIONS AND
REFERENCE DATA**

Specifications A-1
 Physical A-1
 Mechanical A-1
 Electrical A-3
 Performance A-3
 Functional A-3
Dimensional Drawings A-6
 2160 Thread Mounting (Standard Length) A-6
 2160 Thread Mounting (Extended Length) A-7
 2160 Flange Mounting (Standard Length) A-8
 2160 Flange Mounting (Extended Length) A-9
 2160 Hygienic Fitting (Standard Length) A-10
 2160 Hygienic Fitting (Extended Length) A-12
Ordering Information A-13
 Spare Parts and Accessories A-15

**APPENDIX B PRODUCT
CERTIFICATIONS**

European Directive Information B-1
Telecommunication Compliance B-1
FCC and IC Approvals B-1
Canadian Registration Number B-2
Hazardous Locations Certifications B-2
 American and Canadian Approvals B-2
 European Approvals B-2
 Rest Of The World Approvals B-3

Section 1 Overview

Safety Messages	page 1-1
Using This Manual	page 1-2
Definitions And Abbreviations	page 1-2
Models Covered	page 1-2
About the 2160	page 1-3
Service Support	page 1-9
Product Recycling/Disposal	page 1-9

SAFETY MESSAGES

Procedures and instructions in this manual may require special precautions to ensure the safety of the personnel performing the operations. Information that raises potential safety issues is indicated by a caution symbol (⚠). The external hot surface symbol (🔥) is used when a surface is hot and care must be taken to avoid possible burns. If there is a risk of an electrical shock the (⚡) symbol is used. Refer to the safety messages listed at the beginning of each section before performing an operation preceded by this symbol.

Warnings

⚠ WARNING

Failure to follow these installation guidelines could result in death or serious injury

- The Rosemount 2160 is a *wireless liquid level switch*. It must be installed, connected, commissioned, operated, and maintained by suitably qualified personnel only, observing any national and local requirements that may apply
- Use the equipment only as specified in this manual. Failure to do so may impair the protection provided by the equipment

Explosions could result in death or serious injury

- Installation of the 2160 in a hazardous environment must be in accordance with the appropriate local, national, and international standards, codes, and practices. Please review the approvals section of the 2160 Reference Manual for any restrictions associated with an installation
- Before connecting a Field Communicator in an explosive atmosphere, ensure the installation is in accordance with intrinsically safe or non-incendive field wiring practices
- Verify that the operating atmosphere of the level switch is consistent with the appropriate hazardous locations certifications

External Surface may be hot

- Care must be taken to avoid possible burns

Process leaks could result in death or serious injury

- Install and tighten process connectors before applying pressure
- Do not attempt to loosen or remove process connectors while the 2160 is in service

Electrical shock could cause death or serious injury

- If the liquid level switch is installed in a high voltage environment and a fault condition or installation error occurs, high voltage may be present on leads and terminals
- Use extreme caution when making contact with the leads and terminals
- Make sure that power to the 2160 is off while making connections

Rosemount 2160

USING THIS MANUAL

This manual provides information on installing, operating, and maintaining the Rosemount 2160 Wireless liquid level switch.

- **Section 2: Configuration** provides instruction on commissioning and operating the Rosemount 2160. Information on software functions, configuration parameters, and online variables is also included.
- **Section 3: Installation** contains mechanical and electrical installation instructions.
- **Section 4: Commissioning** contains techniques for properly commissioning the device.
- **Section 5: Operation and Maintenance** contains operation and maintenance techniques.
- **Appendix A: Specifications and Reference Data** supplies reference and specification data, as well as ordering information.
- **Appendix B: Product Certifications** contains approval information.

DEFINITIONS AND ABBREVIATIONS

The following definitions are used in this manual:

Dry	The 2160 fork (sensor) is submerged to a depth of <i>less than</i> 0.5 in. (13 mm)
Wet	The 2160 fork (sensor) is submerged to a depth of <i>greater than</i> 0.5 in. (13 mm)
Fault	The fork frequency is outside the normal frequency band
Normal Mode	The operating mode in which the 2160 considers a 0 Hz fork frequency to represent a Wet condition (and not a Fault)
Enhanced Mode	The operating mode in which the 2160 considers a 0 Hz fork frequency to represent a fault condition

The following abbreviations are used in this manual:

DD	Device Description
IS	Intrinsically Safe
PV	Primary Value or Process Value
SV	Secondary Value
TV	Tertiary Value (Third Value)
QV	Quaternary Value (Fourth Value)

MODELS COVERED

The following models of the Rosemount 2160 Wireless liquid level switch are covered in this manual:

- The standard temperature 2160***S
- The extreme temperature 2160***E

ABOUT THE 2160

Switch Overview

The Rosemount 2160 Wireless is a wireless liquid point level switch.

Based on vibrating short fork technology, the 2160 is suitable for virtually all liquid applications:

- Virtually unaffected by flow, bubbles, turbulence, foam, vibration, solids content, coating, properties of the liquid, and product variations
- Operation in extreme temperatures of -94 to 500 °F (-70 to 260 °C)
- No need for calibration and requires minimum installation procedures
- No moving parts or crevices means virtually no maintenance
- Electronic self-checking and condition monitoring
- Programmable switching delay for turbulent or splashing applications
- Short fork length with extensions up to 118 in. (3 m)
- “Fast Drip” fork design gives quick response time
- General area and Intrinsically Safe options

This combination of features makes the 2160 an ideal choice for a wide variety of challenging applications in the chemical, power generation, and oil and gas industries.

Figure 1-1. Features of the 2160

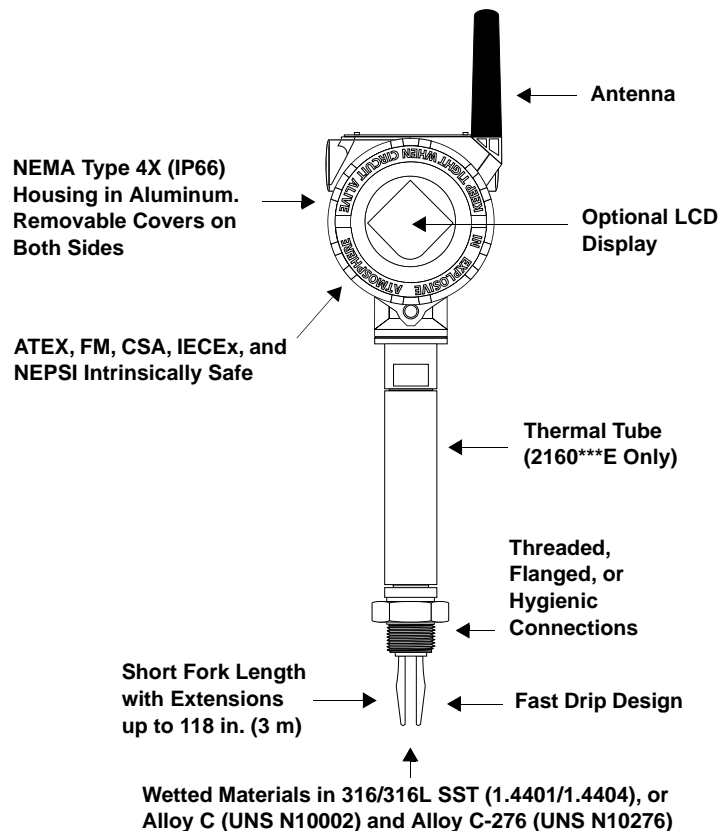

Rosemount 2160

Measurement Principle

The Rosemount 2160 is designed using the principle of a tuning fork. A piezo-electric crystal oscillates the forks at their natural frequency. Changes to this frequency are continuously monitored.

The frequency of the vibrating fork sensor changes depending on the medium in which it is immersed. The denser the liquid, the lower the frequency.

When used as a **low level alarm**, the liquid in the tank or pipe drains down past the fork, causing a change of natural frequency that is detected by the electronics and *switches* the output state to a **Dry condition**.

When the 2160 switch is used as a **high level alarm**, the liquid rises in the tank or pipe making contact with the fork, causing the output state to *switch* to a **Wet condition**.

The output state, along with other parameters, are regularly transmitted over a secure wireless connection to a Smart Wireless Gateway.

Short Fork Technology

The natural frequency (~1400Hz) of the fork avoids interference from plant vibration that may cause false switching. This allows for minimum intrusion into the tank or pipe through the use of a short fork.

Using Short Fork Technology, the Rosemount 2160 can be used in almost all liquid applications. Extensive research has maximized the operational effectiveness of the fork design, making it suitable for most liquids including coating liquids, aerated liquids, and slurries.

Special Features

Instrument Health Monitor and Continuous Self-Check

The 2160 continuously performs instrument health diagnostics to self-check the condition of the fork and sensor. These diagnostics can detect damage to the forks including corrosion, internal or external damage to the forks, and breakages to the internal wiring.

See "Operation Mode" on page 2-9 for further information.

Fork Design

The "fast drip" fork design draws liquid away from the fork tips, and together with a short switching delay, allows the 2160 to react quickly and with greater sensitivity to density variations.

Battery Powered

The 2160 is powered by an integral battery. The fork sensor requires very little power and the battery life remains long even with fast update rates.

See "Battery Installation" on page 3-6 for further information.

Adjustable Time Delay

There is also a user-selectable time delay to virtually eliminate the risk of false switching in turbulent or splashing applications.

See "Sensor Output Delay" on page 2-10 for further information.

Rosemount 2160 Application Examples

For most liquids, including coating, aerated liquids and slurries, the function is virtually unaffected by flow, turbulence, bubbles, foam, vibration, solid particles, build-up, or properties of the liquid.

See Figure 1-5 on page 1-8 for application examples.

The 2160 switch can be used in hazardous (IS) or non-hazardous (safe) areas but supports higher process temperatures up to 500 °F (260 °C).

The switch can be mounted in almost any position in an open or closed tank or pipe. There is a wide range of threaded, flanged, or hygienic connections.

Application Considerations:

- Ensure the process is operating within the instrument operating temperature and pressure ranges (see “Specifications” on page A-1)
- Ensure the liquid viscosity is within the recommended viscosity range (see “Specifications” on page A-1)
- Check that the liquid density is higher than 31.2 lb/ft³ (500 kg/m³) (see “Specifications” on page A-1)
- Check for risk of build-up on the forks

Avoid situations where drying and coating products may create excessive build-up (see Figure 1-2)

- Ensure there is no risk of ‘bridging’ the forks

Examples of products that can create bridging of forks are dense paper slurries and bitumen

- Check the solids content in the liquid

As a guideline, the maximum solid particle diameter in the liquid is 0.2 in. (5 mm). Extra consideration is needed when dealing with particles bigger than 0.2 in. (5 mm). Consult the factory for advice.

- Problems may occur if product coats and dries causing caking.
- In almost all cases, the 2160 is insensitive to foams (i.e. does not see the foam).

However in rare occasions, some very dense foams may be seen as liquid; a known example of this is found in ice-cream and orange juice manufacturing.

Figure 1-2.
Avoid Product Build-up

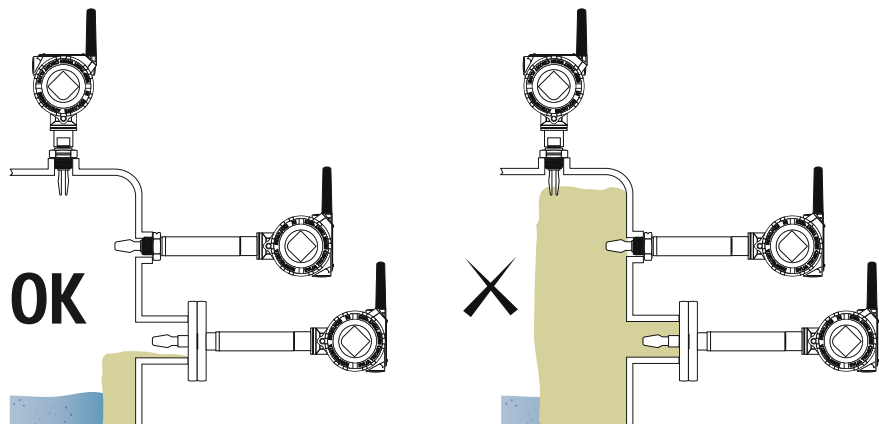

Extended Fork Supports

Figure 1-3. Supports Needed for Extended Forks

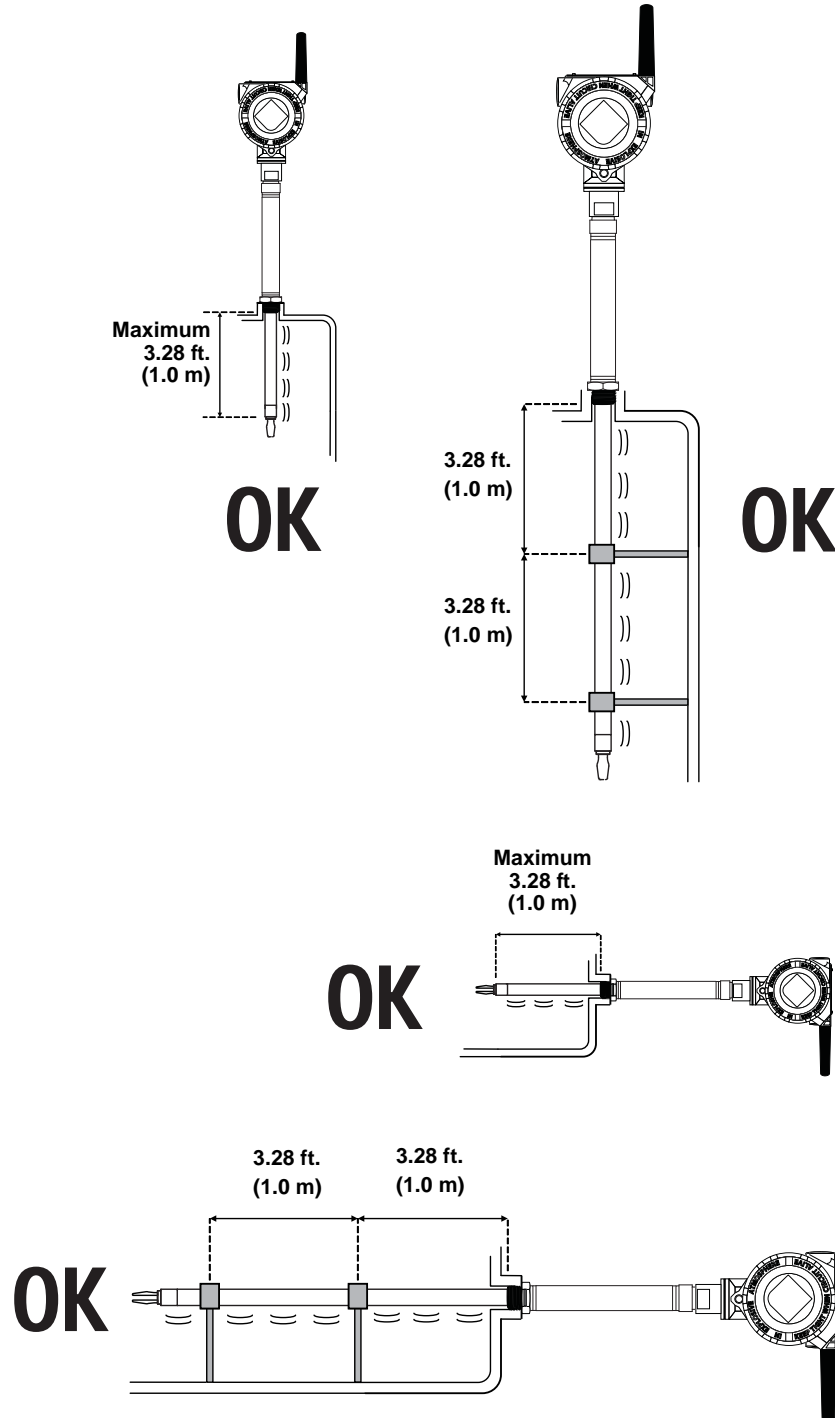

Switchpoint

Figure 1-4. Switchpoint

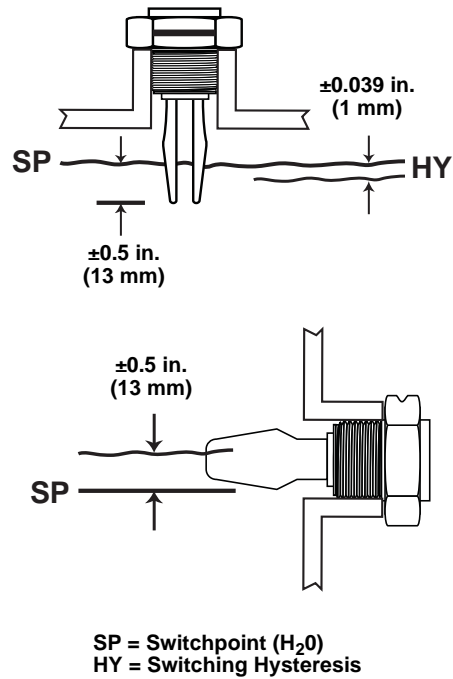

NOTE:

A lower density media will give a switchpoint closer to the connection.
A higher density media will give a switchpoint closer to the fork tip.

Rosemount 2160

Figure 1-5. Rosemount 2160
Application Examples



Overfill Protection

Spillage caused by overfilling can be hazardous to people and the environment, resulting in lost product and potentially high clean up costs.

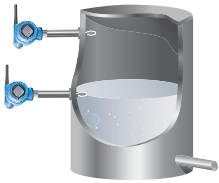

High and Low Level Alarm

Maximum and minimum level detection in tanks containing different types of liquids are ideal applications. The Rosemount 2160 is robust and operates continuously across the temperature range of -94 to 500 °F (-70 to 260 °C) and operating pressures of up to 1450 psig (100 barg), making it perfect for use as a high or low level alarm. It is common practice to have an independent high level alarm switch as a backup to an installed level device in case of primary failure.

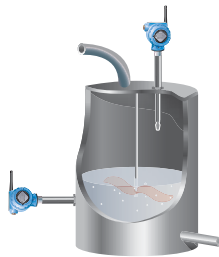

Pump Control (Limit Detection)

Batch processing tanks often contain stirrers and agitators to ensure mixing and product 'fluidity'. The standard user-selectable time delay, from 0 to 3600 seconds, virtually eliminates the risk of false switching from splashing.



Pump Protection or Empty Pipe Detection

With the fork projecting only 2 in. (50 mm) (dependant on connection type), the 2160 can be installed in small diameter pipes. Short forks mean minimum intrusion on the wet side and allow for simple, low cost installation at any angle into pipes or tanks. The 2160 is ideal for reliable pump control and can be used to protect against pumps running dry.



Extreme Temperature Applications

The 2160***E is designed for extreme temperatures and is suitable for continuous operation within the temperature range of -94 to 500 °F (-70 to 260 °C).



Hygienic Applications

With the highly polished forks option providing a surface finish (Ra) better than 0.4 μm , the 2160 meets the most stringent hygienic requirements used in food and beverage, and pharmaceutical applications.

SERVICE SUPPORT

To expedite the return process outside of North America, contact the nearest Emerson Process Management representative.

Within the United States, call the Emerson Process Management Response Center toll-free number 1 800 654 7768. This center, available 24 hours a day, will assist you with any needed information or materials.

The center will ask for product model and serial numbers, and will provide a Return Material Authorization (RMA) number. The center will also ask for the process material to which the product was last exposed.

⚠ CAUTION

Individuals who handle products exposed to a hazardous substance can avoid injury if they are informed of, and understand, the hazard. If the product being returned was exposed to a hazardous substance as defined by OSHA, a copy of the required Material Safety Data Sheet (MSDS) for each hazardous substance identified must be included with the returned goods.

NOTICE

Shipping considerations for wireless products (lithium batteries):

The unit was shipped to you without the power module installed. Please remove the power module prior to shipping.

Primary lithium batteries (charged or discharged) are regulated in transportation by the U. S. Department of Transportation. They are also covered by IATA (International Air Transport Association), ICAO (International Civil Aviation Organization), and ARD (European Ground Transportation of Dangerous Goods). It is the responsibility of the shipper to ensure compliance with these or any other local requirements. Please consult current regulations and requirements before shipping.

**PRODUCT
RECYCLING/DISPOSAL**

Recycling of equipment and packaging should be taken into consideration and disposed of in accordance with local and national legislation/regulations.

Section 2 Configuration

Safety Messages	page 2-1
Overview	page 2-2
Required Bench Top Configuration	page 2-2
Device Network Configuration	page 2-7
Field Communicator	page 2-4
Review Configuration Data	page 2-8
Check Output	page 2-9
Basic Setup	page 2-9
LCD Display	page 2-11
Detailed Setup	page 2-12
Diagnostics and Service	page 2-15
Calibration	page 2-21
Simulation	page 2-23
Advanced Functions for HART Protocol	page 2-24

SAFETY MESSAGES

Procedures and instructions in this section may require special precautions to ensure the safety of the personnel performing the operations. Information that raises potential safety issues is indicated by a warning symbol (⚠). Refer to the following safety messages before performing an operation preceded by this symbol.

Warnings

⚠ WARNING

Failure to follow these installation guidelines could result in death or serious injury

- The Rosemount 2160 is a *wireless liquid level switch*. It must be installed, connected, commissioned, operated, and maintained by suitably qualified personnel only, observing any national and local requirements that may apply
- Use the equipment only as specified in this manual. Failure to do so may impair the protection provided by the equipment

Explosions could result in death or serious injury

- Installation of the 2160 in a hazardous environment must be in accordance with the appropriate local, national, and international standards, codes, and practices. Please review the approvals section of the 2160 Reference Manual for any restrictions associated with an installation
- Before connecting a Field Communicator in an explosive atmosphere, ensure the installation is in accordance with intrinsically safe or non-incendive field wiring practices
- Verify that the operating atmosphere of the level switch is consistent with the appropriate hazardous locations certifications

External Surface may be hot

- Care must be taken to avoid possible burns

Process leaks could result in death or serious injury

- Install and tighten process connectors before applying pressure
- Do not attempt to loosen or remove process connectors while the 2160 is in service

⚠ WARNING

Electrical shock could cause death or serious injury

- If the liquid level switch is installed in a high voltage environment and a fault condition or installation error occurs, high voltage may be present on leads and terminals
- Use extreme caution when making contact with the leads and terminals
- Make sure that power to the 2160 is off while making connections

OVERVIEW

This section contains information on commissioning and verification that should be performed prior to installation.

Field Communicator and AMS® instructions are given to perform configuration functions. For convenience, Field Communicator fast key sequences are labeled “Fast Keys” for each software function below the appropriate headings.

Example Software Function

Fast Keys	1, 2, 3, etc.
------------------	---------------

REQUIRED BENCH TOP CONFIGURATION

Bench top configuration requires a Field Communicator, AMS, or any Wireless Communicator.

Bench top configuration consists of testing the transmitter and verifying transmitter configuration data. The 2160 can be configured before or after installation (field hook-up). However, configuring the 2160 on the bench before installation ensures that all network settings are working correctly.

When using a Field Communicator, any configuration changes made must be sent to the 2160 by using the “Send” key (F2). AMS configuration changes are implemented when the “Apply” button is clicked.

Squawk Feature

The 2160 feature called “Squawk” can be used to visually identify an individual 2160 in a wireless network. This can be a useful check during the configuration and commissioning of multiple 2160 transmitters.

To find out more about this feature, see “How to Use Squawk” on page 4-4.

AMS Wireless Configurator

AMS is capable of connecting to devices either directly using a HART® modem or wirelessly via the Smart Wireless Gateway.

When configuring on the bench with a HART modem, double click the device icon, then choose the Configure/Setup tab (or right click and select Configure/Setup).

When configuring with the Gateway, double click the device icon and then choose the Configure/Setup tab (or right click and select Configure/Setup).

Field Communicator

Remove the power module-side housing cover to expose the terminal block and HART communication terminals, then connect the Black Power Module to power the unit for configuration. Connect the Field Communicator leads to the terminals labeled “COMM” on the terminal block. See Figure 2-1 on page 2-3. Turn on the Field Communicator by pressing the ON/OFF key.

The Field Communicator will search for a HART-compatible device and indicate when the connection is made. If the Field Communicator fails to connect, it indicates that no device was found and you should re-check the connections.

NOTE

Before connecting a Field Communicator in an explosive atmosphere, make sure the instruments are installed in accordance with intrinsically safe or non-incendive field wiring practices.

Figure 2-1.
Field Communicator Connection

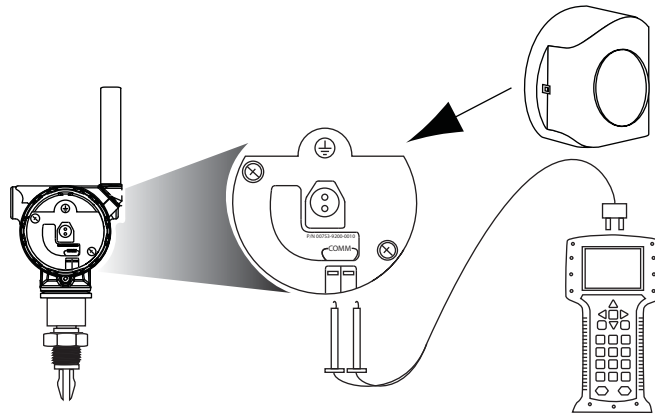

A 2160 DD (Device Description) is required for HART communication. To obtain the latest DD, visit the Emerson Process Management Easy Upgrade Site at:

<http://www2.emersonprocess.com/en-US/documentation/deviceinstallkits>

FIELD COMMUNICATOR

Field Communicator Menu Tree

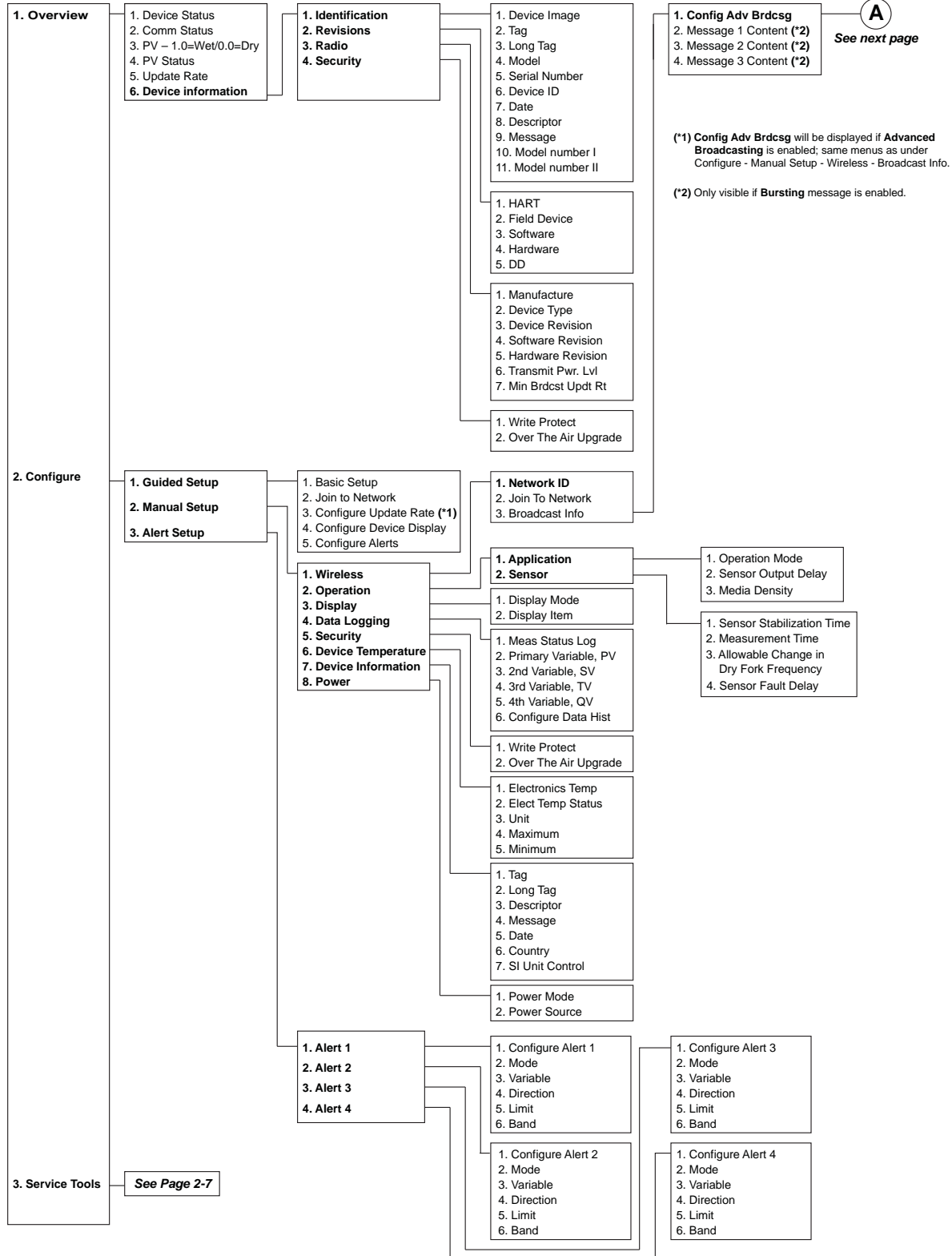

Field communicator menu tree continued...

From previous page

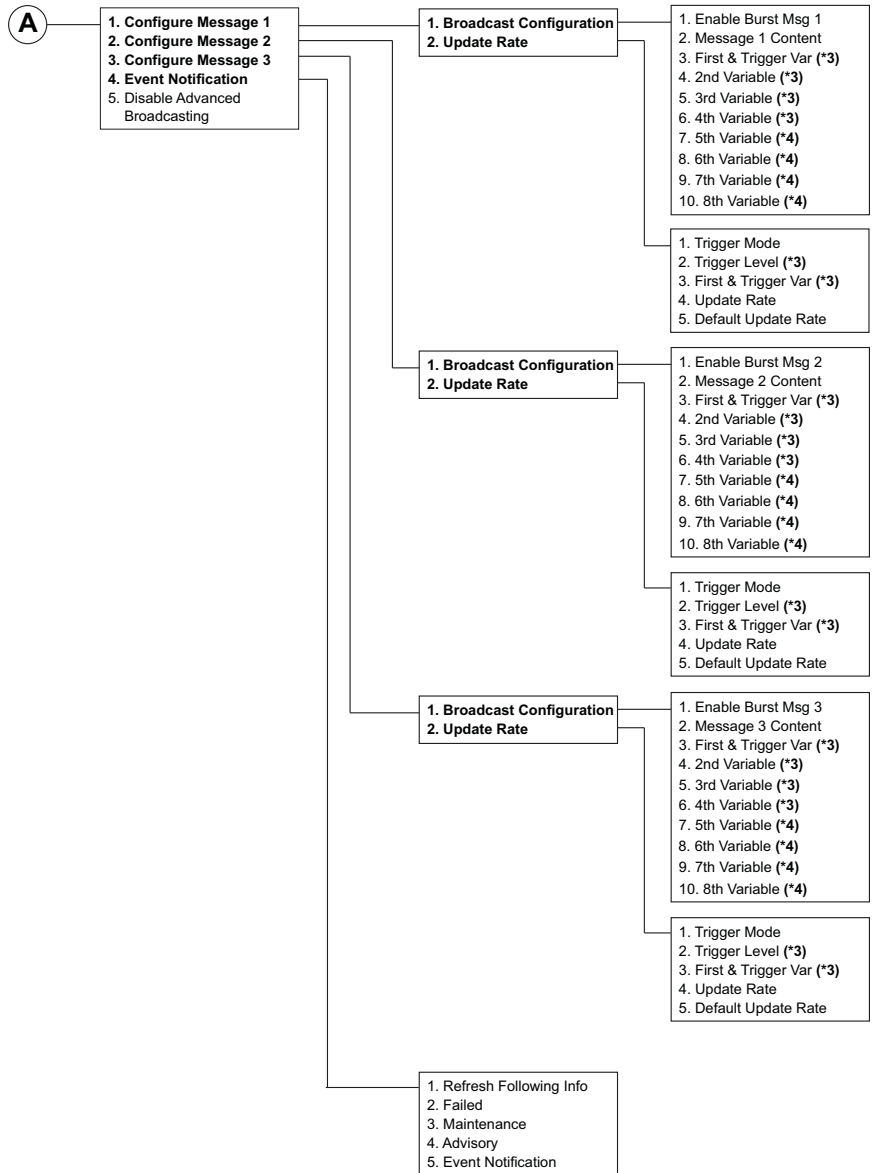

(*3) Only visible if **Message Content** is "Selectable Process Variables/Status" or "Selectable Process Variables".

(*4) Only visible if **Message Content** is "Selectable Process Variables/Status".

Rosemount 2160

Field communicator menu tree continued...

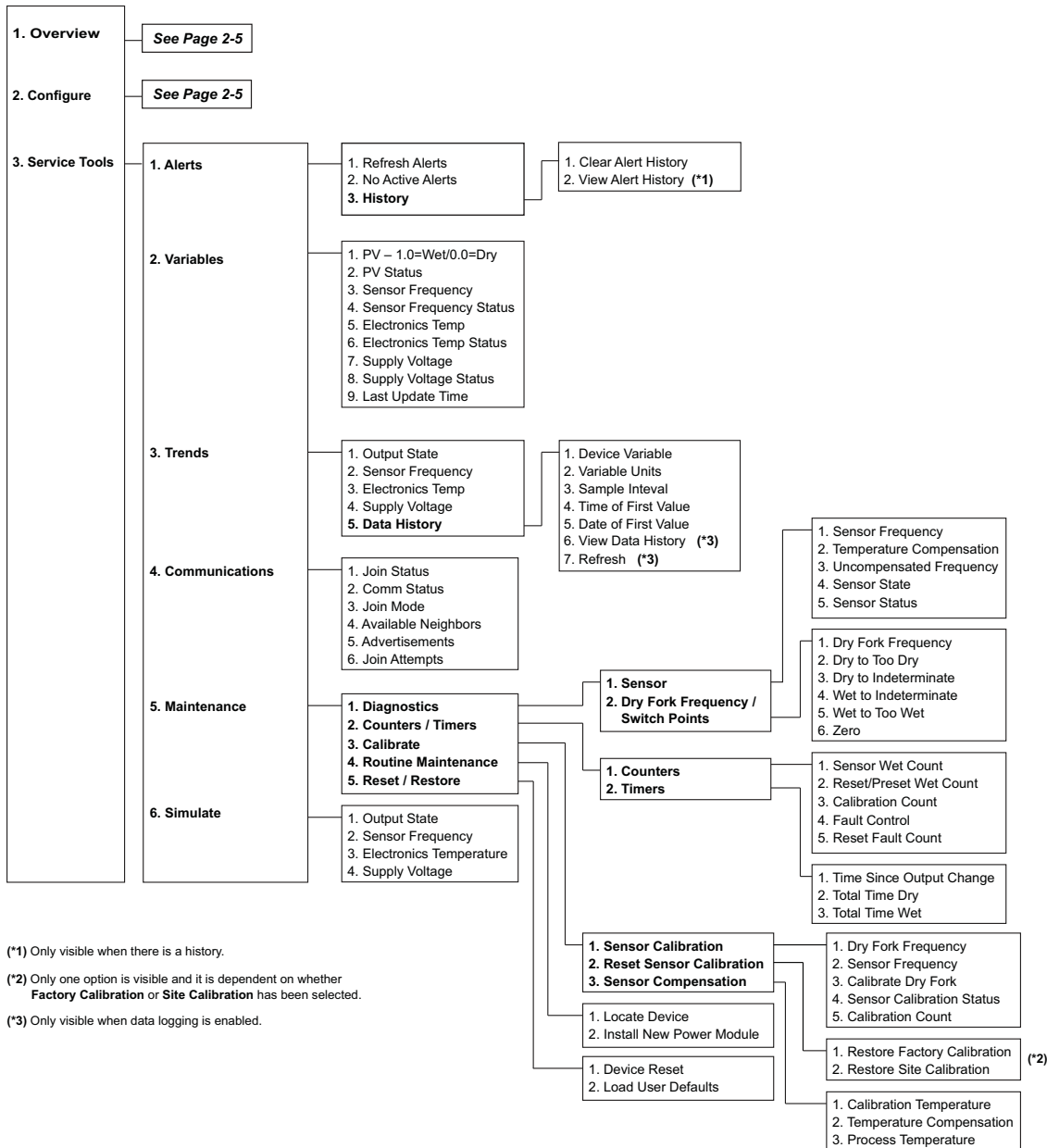

(*1) Only visible when there is a history.

(*2) Only one option is visible and it is dependent on whether **Factory Calibration** or **Site Calibration** has been selected.

(*3) Only visible when data logging is enabled.

DEVICE NETWORK CONFIGURATION

Join to Network

Fast Keys	2, 1, 2
-----------	---------

To communicate with the Smart Wireless Gateway, and ultimately the Information System, the 2160 must be configured to communicate with the wireless network. This step is the wireless equivalent of connecting wires from a transmitter to the host system.

1. From the *Home* screen, select **2: Configure**.
2. Select **1: Guided Setup**.
3. Select **1: Join to Network**.

Using AMS or a Field Communicator, enter the **Network ID** and **Join Key** so they match the Network ID and Join Key of the Gateway and the other devices in the network. If the Network ID and Join Key are not identical, the 2160 will not communicate with the network.

When using a Field Communicator, the Network ID can be configured by entering Fast Key sequence: 2, 2, 1, 1. The Join Key can also be configured using a Field Communicator with the Fast Key sequence: 2, 2, 1, 2.

NOTE

The Network ID and Join Key may be obtained from the **Setup>Network>Settings** page on the Gateway's web server.

Configure Update Rate

Fast Keys	2, 2, 3
-----------	---------

The final device network configuration piece is the **Update Rate** which, by default, is 1 minute. It can be changed at commissioning, or at any time, by using AMS or the Gateway's web server. The Update Rate should be between 1 second and 60 minutes.

1. From the *Home* screen, select **2: Configure**.
2. Select **1: Guided Setup**.
3. Select **3: Configure Update Rate**.

Operation Mode

Fast Keys	2, 2, 2, 1, 1
-----------	---------------

To view or change the operation mode:

1. From the *Home* screen, select **2: Configure**.
2. Select **2: Manual Setup**.
3. Select **2: Operation**.
4. Select **1: Application**.
5. Select **1: Operation Mode**.

The default operating mode is Normal Mode. Other options are Enhanced Operation Mode (Fault=Wet) or Enhanced Operation Mode (Fault=Dry).

Remove Black Power Module

After the bench top and network device configuration is completed, you can remove the Black Power Module and replace the housing cover. The Black Power Module should be inserted only when the device is ready to be installed.

Use caution when handling the Black Power Module. The Black Power Module may be damaged if dropped from heights in excess of 20 ft. (6,1 m).

When the device is installed, re-insert the Black Power Module and close the housing cover securely. Always ensure a proper seal but do not over tighten.

Rosemount 2160

REVIEW CONFIGURATION DATA

The following is a list of factory default configurations that can be viewed by using the Field Communicator or AMS. Follow the steps below to review the level switch configuration information.

NOTE

Information and procedures in this section that make use of Field Communicator fast key sequences and AMS assume that the 2160 and communication equipment are connected, powered, and operating correctly.

Review Device Identification Information

Fast Keys	1, 6, 1, 3
-----------	------------

To view device identification information:

1. From the *Home* screen, select **1: Overview**.
2. Select **6: Device Information**.
3. Select **1: Identification**.
4. Select **3: Device**.
5. Select from the corresponding number to view each field:

1	Device Image
2	Tag
3	Long Tag
4	Model
5	Serial Number
6	Device ID
7	Date
8	Descriptor
9	Message
10	Model Number I
11	Model Number II

NOTE

Other device information can also be found at Fast Key sequence 2, 2, 7.

Review Radio Information

Fast Keys	1, 6, 3
-----------	---------

To view radio information:

1. From the *Home* screen, select **1: Overview**.
2. Select **6: Device Information**.
3. Select **3: Radio**.
4. Select from the corresponding number to view each field:

1	Manufacturer
2	Device Type
3	Device Revision
4	Software Revision
5	Hardware Revision
6	Transmit Power Level
7	Minimum Broadcast Update Rate

CHECK OUTPUT

Before performing other level switch operations, ensure the 2160 is operating properly by checking the process variables.

Variables

Fast Keys	3, 2
-----------	------

To view the Variables menu:

1. From the *Home* screen, select **3: Service Tools**.
2. Select **2: Variables**.

The variable menu displays the following process variables:

- **PV** – level switch output state of **0.0** (Dry) or **1.0** (Wet)
- **PV Status** – valid or fault status (see “Troubleshooting” on page 6-2)
- **Sensor Frequency** – the frequency of the vibrating fork
- **Sensor Frequency Status** – valid or fault status
- **Electronics Temp** – the temperature inside the 2160 housing
- **Electronics Temp Status** – valid or fault status
- **Supply Voltage** – the input voltage to the level switch
- **Supply Volt Status** – valid or fault status
- **Last Update Time** – elapsed time since the last data update

BASIC SETUP

Temperature Units

Fast Keys	2, 2, 6
-----------	---------

The **Unit** setting allows the **Electronics Temperature** process variable to be displayed in Fahrenheit (°F) or Celsius (°C).

To view the electronics temperature menu:

1. From the *Home* screen, select **2: Configure**.
2. Select **2: Manual Setup**.
3. Select **6: Device Temperature**.

The electronics temperature menu displays the following:

- **Electronics Temp** – the live electronics temperature measurement
- **Electronics Temp Status** – valid or fault status
- **Unit** – change/view measurement units for **Electronics Temperature**
- **Maximum** – view the highest measured electronics temperature
- **Minimum** – view the lowest measured electronics temperature

Operation Mode

Fast Keys	2, 2, 2, 1, 1
-----------	---------------

The 2160 has three operation modes (see Table A-2 on page A-3):

- **Standard** – Default operation mode for no sensor fault detection
- **Enhanced (Fault=WET)** – Output is forced to Wet when fault detected
- **Enhanced (Fault=DRY)** – Output is forced to Dry when fault detected

To change or view the operation mode:

1. From the *Home* screen, select **2: Configure**.
2. Select **2: Manual Setup**.
3. Select **2: Operation**.
4. Select **1: Application**.
5. Select **1: Operation Mode**.

Rosemount 2160

Sensor Output Delay

Fast Keys	2, 2, 2, 1, 2
-----------	---------------

When the 2160 detects a change in process conditions from wet-to-dry or dry-to-wet, the **Sensor Output Delay** parameter causes a delay of up to 3600 seconds before a new process condition is indicated in the process variables.

If, for example, there are waves in a tank, then the 2160 may intermittently detect a change in process conditions. The sensor output delay ensures that the 2160 fork is dry or wet for a period before switching.

Depending on the application, a suitable delay can prevent constant switching of the output state.

NOTE

The delay re-starts each time a change in process conditions is detected.

To change or view the sensor output delay:

1. From the *Home* screen, select **2: Configure**.
2. Select **2: Manual Setup**.
3. Select **2: Operation**.
4. Select **1: Application**.
5. Select **2: Sensor Output Delay**.

Media Density

Fast Keys	2, 2, 2, 1, 3
-----------	---------------

The frequency of the vibrating fork sensor can be affected by the process liquid density. Use **Media Density** to select one of the following options:

- Normal – *Select when the liquid specific gravity is between 0.7 and 2.0*
- Low – *Select when the liquid specific gravity is less than 0.7*
- High – *Select when the liquid specific gravity is greater than 2.0*

NOTE

If the liquid specific gravity is unknown, keep the default setting of Normal.

Write Protect

Fast Keys	2, 2, 5, 1
-----------	------------

The 2160 has a software write protect security feature.

The change or view write protect security settings:

1. From the *Home* screen, select **2: Configure**.
2. Select **2: Manual Setup**.
3. Select **5: Security**.
4. Select **1: Write Protect**.

Data Logging

Fast Keys	2, 2, 4, 6
-----------	------------

Data logging records previous measurement values.

To enable or disable the logging:

1. From the *Home* screen, select **2: Configure**.
2. Select **2: Manual Setup**.
3. Select **4: Data Logging**.
4. Select **6: Configure Data Hist**.

Follow on-screen instructions to enable or disable the logging.

LCD DISPLAY

LCD Display Configuration

The LCD display indicates output and abbreviated diagnostic messages.

Fast Keys	2, 1, 4
-----------	---------

NOTE

Use Rosemount Wireless LCD Part Number: 00753-9004-0002.

The LCD display features a four-line display and a bar graph. The first line of five characters displays the output description, the second line of seven digits displays the actual value, the third line of six characters displays engineering units, and the fourth line displays "Error" when there is an alarm condition. The LCD display can also display diagnostic messages. The bar graph represents the network connectivity status.

See "LCD Screen Messages" on page 5-3 for more information on LCD messages.

To change or view LCD display options:

1. From the *Home* screen, select **2: Configure**.
2. Select **1: Guided Setup**.
3. Select **4: Configure Device Display**.

Alternatively, to manually change or view LCD display options:

1. From the *Home* screen, select **2: Configure**.
2. Select **2: Manual Setup**.
3. Select **3: Display**.
4. Follow the on-screen instructions to configure **Display Mode** and **Display Item** parameters.

DETAILED SETUP

Configure Alerts

Fast Keys	2, 1, 5
-----------	---------

Alerts can be configured to output a HART message when a configured data point is exceeded. A process alert is transmitted continuously if a set point for a process variable is exceeded and the alert mode is enabled.

An alert is displayed on a Field Communicator, AMS status screen, or in the error section of the optional LCD display. The alert is reset when the assigned value (process variable) returns within its normal range.

Example 1: Rising Alert

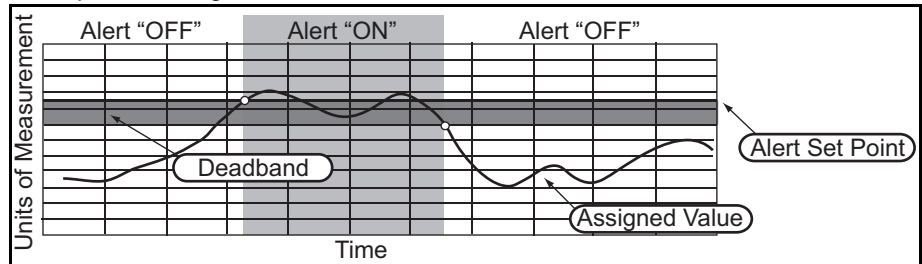

Example 2: Falling Alert

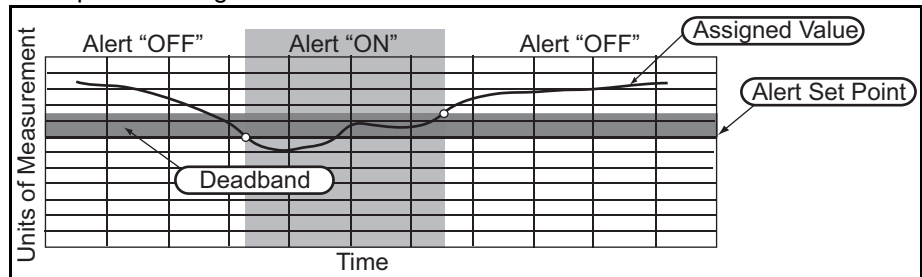

To change or view the process alerts:

1. From the *Home* screen, select **2: Configure**.
2. Select **1: Guided Setup**.
3. Select **5: Configure Alerts**.
4. Follow the on-screen instructions to configure up to four alerts (Alert 1, Alert 2, Alert 3, and Alert 4).

Each alert requires the following information:

- Mode – *Disabled (default) or enabled alert*
- Variable – **Select *Output State, Sensor Frequency, Electronics Temperature, or Supply Voltage***
- Direction – *Rising or falling alert*
- Limit – *Alert set point (in same units as the variable)*
- Dead Band – *Hysteresis data point (in same units as the variable) for transition from deadband zone to new alert state*

To view active or previous alerts:

1. From the *Home* screen, select **3: Service Tools**.
2. Select **1: Alerts**.
3. Select **Refresh Alerts** to report new alerts since the last update, **Active Alerts** to view *active alerts*, or **History** to view *previous alerts*.

Sensor Stabilization Time

Fast Keys	2, 2, 2, 2, 1
-----------	---------------

The time needed for the fork sensor to reach a *stable vibration* may vary depending on the process conditions. **Sensor Stabilization Time** sets a delay before taking a frequency measurement.

The default setting is 60 ms. It can be set to a time in the range 20 to 1000 ms and is adjustable in 20 ms steps. Alternatively, the setting AUTO is for the Rosemount 2160 to automatically calculate a delay.

To change or view the sensor stabilization time:

1. From the *Home* screen, select **2: Configure**.
2. Select **2: Manual Setup**.
3. Select **2: Operation**.
4. Select **2: Sensor**.
5. Select **1: Sensor Stabilization Time**.
6. Follow the on-screen instructions to configure a delay.

Measurement Time

Fast Keys	2, 2, 2, 2, 2
-----------	---------------

The time needed for the fork sensor to take an accurate measurement *after reaching a stable vibration* may vary depending on the process conditions. **Measurement Time** sets a delay before taking a frequency measurement.

The default setting is 60 ms. It can be set to a time in the range 20 to 1000 ms and is adjustable in 20 ms steps. Alternatively, the setting AUTO is for the Rosemount 2160 to automatically calculate a delay.

To change or view the measurement time:

1. From the *Home* screen, select **2: Configure**.
2. Select **2: Manual Setup**.
3. Select **2: Operation**.
4. Select **2: Sensor**.
5. Select **2: Measurement Time**.
6. Follow the on-screen instructions to configure a delay.

Allowable Change In Dry Fork Frequency

Fast Keys	2, 2, 2, 2, 3
-----------	---------------

When the 2160 is re-calibrated in the field, a comparison is made between the new dry fork frequency and original factory-set **Dry Fork Frequency** value. If the difference is greater than the allowable change value, the re-calibration is rejected. Check the fork for damage, corrosion, or coating, and clean the fork if necessary before re-trying.

The default setting is 100 Hz. It can be set to a value in the range 1 to 254 Hz.

NOTE

Fast Key sequence is 3, 5, 1, 2 for the original factory-set Dry Fork Frequency.

To change or view the allowable change:

1. From the *Home* screen, select **2: Configure**.
2. Select **2: Manual Setup**.
3. Select **2: Operation**.
4. Select **2: Sensor**.
5. Select **3: Allowable Change In Dry Fork Frequency**.
6. Follow the on-screen instructions to configure the allowable change.

Rosemount 2160

Sensor Fault Delay

Fast Keys	2, 2, 2, 2, 4
-----------	---------------

When the 2160 is operating in Enhanced Mode and detects a fork sensor fault, **Sensor State** (page 2-18) indicates a Fault state after a delay set by **Sensor Fault Delay**.

The default setting is 600 seconds. It can be a maximum of 3600 seconds.

NOTE

When the 2160 is operating in Normal Mode, a fork sensor fault is not detected and **Sensor State** (page 2-18) continues to indicate a Valid state.

To change or view the sensor fault delay:

1. From the *Home* screen, select **2: Configure**.
2. Select **2: Manual Setup**.
3. Select **2: Operation**.
4. Select **2: Sensor**.
5. Select **4: Sensor Fault Delay**.
6. Follow the on-screen instructions to configure the sensor fault delay.

Power Mode

Fast Keys	2, 2, 8, 1
-----------	------------

For configuration and diagnostic purposes, the 2160 can be put into an Always On power mode. The fork sensor is energized continuously and a new measurement is completed, typically, every 500 ms.

The Always On power mode causes a much higher drain on the battery, and so the 2160 reverts to the default Normal power mode after a settable period of up to 10 minutes.

In Normal power mode, the fork sensor is energized for the period set by the update rate (see "Configure Update Rate" on page 2-7).

To view or change **Power Mode**:

1. From the *Home* screen, select **2: Configure**.
2. Select **2: Manual Setup**.
3. Select **8: Power**.
4. Select **1: Power Mode**.
5. Follow the on-screen instructions to configure the power mode.

Power Source

Fast Keys	2, 2, 8, 2
-----------	------------

A wireless device may be attached to a source of continuous power or to a power source that drains over time (e.g. a battery). The 2160 is always powered by Battery Power.

To view the **Power Source**:

1. From the *Home* screen, select **2: Configure**.
2. Select **2: Manual Setup**.
3. Select **8: Power**.
4. Select **2: Power Source**.

DIAGNOSTICS AND SERVICE

Diagnostics and service functions listed below are primarily for use after field installation.

Load User Defaults

Fast Keys	3, 5, 2
-----------	---------

The master reset function is used to reset the electronics and **reset parameters to their factory-set defaults** (see Table 2-1).

To perform a master reset:

1. From the *Home* screen, select **3: Service Tools**.
2. Select **5: Maintenance**
3. Select **2: Load User Defaults**.
4. Follow on-screen instructions to perform the reset.

Table 2-1. User Defaults

Parameter Names		Defaults
Operation Mode		Normal ⁽¹⁾
Media Density		Normal ⁽¹⁾
Sensor Output Delay		0 s
Sensor Stabilisation Time		60 ms
Sensor Frequency Measurement Time		60 ms
Sensor Fault Delay		600 ms
Process Temperature		20 °C ⁽¹⁾
Burst Message 0:	Burst Mode Control	Wireless
	Burst Variable Slot 0	2
	Burst Variable Slot 1	3
	Burst Variable Slot 2	0
	Burst Variable Slot 3	1
	Burst Variable Slot 4	246
	Burst Variable Slot 5	247
	Burst Variable Slot 6	248
	Burst Variable Slot 7	249
	Burst Ext. Cmd Number	178
	Triggered Update Rate	60 s ⁽¹⁾
	Default Update Rate	60 s ⁽¹⁾
	Trigger Mode	Continuous
	Trigger Variable Classification	0
	Trigger Units	251
Trigger Level	0.5	
Alerts:	Alert Variable Assignment	2 ⁽¹⁾
	Alert Mode	Off ⁽¹⁾
	Alert Direction	Rising ⁽¹⁾
	Alert Set Point	0.0 ⁽¹⁾
	Alert Dead Band	0.0 ⁽¹⁾
	Alert Units	251 ⁽¹⁾
Alert Name	ALERT X ⁽¹⁾	
Data Trending:	Trend Number	0
	Trend Control	Off
	Device Variable Code	Not Used
	Sample Period	60 s
Sensor Wet Count		0
Fault Count		0
Total Time Wet		00, 00:00:00
Total Time Dry		00, 00:00:00
Time Since Output Change		00, 00:00:00
Sensor Calibration Status		Factory Calibrated
Allowable Dry Fork Frequency Shift		100 Hz
Temperature Coefficient		-0.019 %/°C

Rosemount 2160

(1) Where this parameter was factory-configured with a user-defined value, that same value is re-loaded when using the Load User Defaults function. Parameters without a user-defined value are restored to the default value shown in this table.

Join Status

Fast Keys	3, 4, 1
-----------	---------

Wireless devices join the secure network through a four step process:

- Step 1. Network Found
- Step 2. Network Security Clearance Granted
- Step 3. Network Bandwidth Allocated
- Step 4. Network Join Complete

To view the join status of the Rosemount 2160:

1. From the *Home* screen, select **3: Service Tools**.
2. Select **4: Communications**.
3. Select **1: Join Status**.

Communication Status

Fast Keys	3, 4, 2
-----------	---------

This indicates whether or not the 2160 is connected to the secure network.

To view the communication status of the 2160:

1. From the *Home* screen, select **3: Service Tools**.
2. Select **4: Communications**.
3. Select **2: Comm Status**.

Join Mode

Fast Keys	3, 4, 3
-----------	---------

This mode configures how the device attempts to join the secure network.

Settable options are:

- Do Not Attempt to Join
- Join Now
- Attempt to Join immediately on Power Up or Reset

To change or view the join mode:

1. From the *Home* screen, select **3: Service Tools**.
2. Select **4: Communications**.
3. Select **3: Join Mode**.

Available Neighbors

Fast Keys	3, 4, 4
-----------	---------

In a self-organizing network, the more neighbors a device has, the more robust the network will be.

To view the number of available neighbors:

1. From the *Home* screen, select **3: Service Tools**.
2. Select **4: Communications**.
3. Select **4: Available Neighbors**.

Advertisements

Fast Keys	3, 4, 5
-----------	---------

To view the number of advertising packets heard from other wireless devices:

1. From the *Home* screen, select **3: Service Tools**.
2. Select **4: Communications**.
3. Select **5: Advertisements**.

Join Attempts

Fast Keys	3, 4, 6
-----------	---------

Too many join attempts result in the device considering the join attempt as failed. If this happens, re-check the **Join Key** and **Network ID**.

To view the number of attempts made to join a secure network:

1. From the *Home* screen, select **3: Service Tools**.
2. Select **4: Communications**.
3. Select **6: Join Attempts**

Sensor Frequency

Fast Keys	3, 5, 1, 1, 1
-----------	---------------

The vibrating fork frequency is indicated in **Sensor Frequency** after process condition adjustments.

NOTE

See “Sensor Stabilization Time” on page 2-13 and “Measurement Time” on page 2-13 for process condition adjustments.

Sensor Frequency is the HART dynamic variable SV (Secondary Variable) and can be indicated instead of the variable PV on the optional LCD display.

To view the vibrating fork frequency (sensor frequency):

1. From the *Home* screen, select **3: Service Tools**.
2. Select **5: Maintenance**.
3. Select **1: Diagnostics**.
4. Select **1: Sensor**.
5. Select **1: Sensor Frequency**.

NOTE

The Fast Key sequence 3, 2, 3 also indicates Sensor Frequency.

Rosemount 2160

Temperature Compensation

Fast Keys	3, 5, 3, 3, 2
-----------	---------------

The frequency of the vibrating fork sensor may be affected by a varying process temperature. If the 2160 knows the process temperature, it can compensate accordingly and provide an improved frequency switching point (page 2-19) and trend calculation.

Use **Temperature Compensation** to set the temperature coefficient of the vibrating fork sensor in units of %/°F (%/°C).

To change or view the temperature coefficient:

1. From the *Home* screen, select **3: Service Tools**.
2. Select **5: Maintenance**.
3. Select **3: Calibrate**.
4. Select **3: Sensor Compensation**.
5. Select **2: Temperature Compensation**.

Uncompensated Frequency

Fast Keys	3, 5, 1, 1, 3
-----------	---------------

Uncompensated Frequency indicates the vibrating fork frequency before compensating for a varying process temperature.

To view the uncompensated frequency:

1. From the *Home* screen, select **3: Service Tools**.
2. Select **5: Maintenance**.
3. Select **1: Diagnostics**.
4. Select **1: Sensor**.
5. Select **3: Uncompensated Frequency**.

Sensor State

Fast Keys	3, 5, 1, 1, 4
-----------	---------------

Sensor State indicates the present state of the vibrating fork.

As the vibrating fork sensor becomes immersed in the process liquid, the vibration frequency changes and the sensor state changes to **Wet**.

When the process liquid falls away from the fork, the vibration frequency changes and the sensor state changes to **Dry**.

If the vibrating fork sensor is damaged, the frequency moves outside normal operating limits and the sensor state changes to **Too Dry**, **Too Wet**, or **Zero**. (See "Dry Fork Frequency / Switch Points" on page 2-19 for band limits.)

To view the sensor state:

1. From the *Home* screen, select **3: Service Tools**.
2. Select **5: Maintenance**.
3. Select **1: Diagnostics**.
4. Select **1: Sensor**.
5. Select **4: Sensor State**.

Dry Fork Frequency / Switch Points

Fast Keys	3, 5, 1, 2
-----------	------------

The hysteresis for **Sensor State** transitions can be viewed in the dry fork frequency and switch points menu:

- **Dry Fork Frequency** – *The frequency recorded when calibrated in dry conditions, and is typically 1.2 to 1.5 KHz*
- **Dry to Too Dry** – *The frequency above which the sensor frequency is considered to be outside of the normal Dry range. (Fault indicated when in Enhanced Mode only).*
- **Dry to Indeterminate** – *The frequency below which the sensor frequency is considered to be outside of the normal Dry range. (Normal hysteresis – see “Switchpoint” on page 1-7).*
- **Wet to Indeterminate** – *The frequency above which the sensor frequency is considered to be outside of the normal Wet range. (Normal hysteresis – see “Switchpoint” on page 1-7).*
- **Wet to Too Wet** – *The frequency below which the sensor frequency is considered to be outside of the normal Wet range. (Fault indicated when in Enhanced Mode only).*
- **Zero** – *The frequency below which the sensor frequency is considered to be 0 Hz. (Fault indicated when in Enhanced Mode only).*

NOTE

When the 2160 is operating in Normal Mode, a 0 Hz sensor frequency represents a Wet condition (and not a Fault). When operating in Enhanced Mode, a 0 Hz sensor frequency represents a fault condition.

Sensor State

Fast Keys	3, 5, 1, 2, 4
-----------	---------------

The 2160 indicates here if it is operating in a Valid or Fault state.

Sensor State is dependent on the **Sensor State** diagnostic (page 2-18) and the **Operation Mode** configuration (page 2-9).

To view the sensor status:

1. From the *Home* screen, select **3: Service Tools**.
2. Select **5: Maintenance**.
3. Select **1: Diagnostics**, and then select **2: Sensor**
4. Select **4: Sensor State**.

Table 2-2. Sensor Status Logic (Normal Mode)

Sensor Status	Sensor State ⁽¹⁾	PV (Output Status)
Valid	Dry	0.0 (Dry)
Valid	Wet	1.0 (Wet)

⁽¹⁾ *Sensor Fault Delay (page 2-14) does not delay the update of Sensor State when the operation mode is Normal.*

NOTE:

If the operation mode is Normal, **Sensor State** cannot indicate Too Dry, Too Wet, or Zero, and the **Sensor Status** always indicates a Valid state.

Rosemount 2160

Table 2-3. Sensor Status Logic
(Enhanced Mode, Fault=Wet)

Sensor Status	Sensor State ⁽¹⁾	PV (Output Status)
Valid	Dry	0.0 (Dry) ⁽²⁾
Fault	Too Dry (Fault)	1.0 (Wet) ⁽³⁾
Valid	Wet	1.0 (Wet) ⁽²⁾
Fault	Too Wet (Fault)	1.0 (Wet) ⁽³⁾
Fault	Zero	1.0 (Wet) ⁽³⁾

(1) *Sensor Fault Delay (page 2-14) delays the update of Sensor State when the operation mode is Enhanced.*

(2) *PV is not changed.*

(3) *PV is automatically changed to 1.0 (Wet process condition).*

Table 2-4. Sensor Status Logic
(Enhanced Mode, Fault=Dry)

Sensor Status	Sensor State ⁽¹⁾	Output Status
Valid	Dry	0.0 (Dry) ⁽²⁾
Fault	Too Dry (Fault)	0.0 (Dry) ⁽³⁾
Valid	Wet	1.0 (Wet) ⁽²⁾
Fault	Too Wet (Fault)	0.0 (Dry) ⁽³⁾
Fault	Zero	0.0 (Dry) ⁽³⁾

(1) *Sensor Fault Delay (page 2-14) delays the update of Sensor State when the operation mode is Enhanced.*

(2) *PV is not changed.*

(3) *PV is automatically changed to 0.0 (Dry process condition).*

Counters

Fast Keys	3, 5, 2, 1
------------------	------------

To view the Counters menu:

1. From the *Home* screen, select **3: Service Tools**.
2. Select **5: Maintenance**.
3. Select **2: Counters / Timers**.
4. Select **1: Counters**.

The Counters / Timers menu displays the following counters:

- **Sensor Wet Count** – *This counter increments each time the PV (Output State) changes from Dry to Wet. This counter can be reset or preset by setting a new value using **2: Reset/Preset Wet Count**.*
- **Calibration Count** – *The 2160 is calibrated under reference conditions at the factory. In special circumstances, it may be re-calibrated in the field and this increments the counter.*
- **Fault Count** – *This counter increments each time there is a Fault condition (see “Sensor State” on page 2-19). This counter can be reset to zero using **5: Reset Fault Count**.*

Timers

Fast Keys	3, 5, 2, 2
-----------	------------

To view the Timers menu:

1. From the *Home* screen, select **3: Service Tools**.
2. Select **5: Maintenance**.
3. Select **2: Counters / Timers**.
4. Select **2: Timers**.

The Timers menu displays the following timers:

- **Time Since Output Change** – *The time elapsed since the PV (Output State) last changed from Wet to Dry or Dry to Wet. This timer can be reset to zero.*
- **Total Time Dry** – *The total time that the PV (Output State) has been Dry. This timer can be reset to zero.*
- **Total Time Wet** – *The total time that the PV (Output State) has been Wet. This timer can be reset to zero.*

NOTE

Units for the timers are days, hours, minutes, and seconds. Seconds are not shown for long times.

CALIBRATION

Dry Fork Frequency

Fast Keys	3, 5, 3, 1, 1
-----------	---------------

The 2160 detects the process is Wet or Dry by monitoring the vibrating fork sensor frequency. **Dry Fork Frequency** is set when calibrated under Dry process conditions at the factory.

See also “Dry Fork Frequency / Switch Points” on page 2-19 for associated parameters.

To view the dry fork frequency:

1. From the *Home* screen, select **3: Service Tools**.
2. Select **5: Maintenance**.
3. Select **3: Calibrate**.
4. Select **1: Sensor Calibration**.
5. Select **1: Dry Fork Frequency**.

NOTE

The Fast Key sequence 3, 5, 1, 2, 1 also indicates Dry Fork Frequency.

Sensor Frequency

Fast Keys	3, 5, 3, 1, 2
-----------	---------------

See “Sensor Frequency” on page 2-17 for a description of this parameter.

Rosemount 2160

Calibrate Dry Fork

Fast Keys	3, 5, 3, 1, 3
-----------	---------------

This command starts the *on-site re-calibration* of the vibrating fork sensor in **Dry process conditions**. It should only be performed by authorized persons.

A comparison is made between the *new dry fork frequency* and original factory-set **Dry Fork Frequency** value (page 2-21). If the difference is greater than **Allowable Change In Dry Fork Frequency** (page 2-13), the re-calibration is rejected. Check the fork for damage, corrosion, or coating, and clean the fork if necessary before re-trying.

When the re-calibration is successful, **Dry Fork Frequency** is set to the *new dry frequency*.

To start the on-site re-calibration:

1. From the *Home* screen, select **3: Service Tools**.
2. Select **5: Maintenance**.
3. Select **3: Calibrate**.
4. Select **1: Sensor Calibration**.
5. Select **3: Calibrate Dry Fork Frequency**.
6. Input the process temperature when prompted.

Sensor Calibration Status

Fast Keys	3, 5, 3, 1, 4
-----------	---------------

The 2160 is supplied with a factory calibration but can be re-calibrated on-site using the **Calibrate Dry Fork** command (page 2-22).

Sensor Calibration Status indicates the 2160 is:

- Factory Calibrated – *No further calibration is normally required.*
- Site Calibrated – *Calibration successfully performed on-site.*
- Un-calibrated – *Calibration is required. Contact the factory.*

Calibration Count

Fast Keys	3, 5, 3, 1, 5
-----------	---------------

See “Counters” on page 2-20 for a description of this parameter.

Reset Calibration

Fast Keys	3, 5, 3, 2
-----------	------------

To reset the calibration:

1. From the *Home* screen, select **3: Service Tools**.
2. Select **5: Maintenance**.
3. Select **3: Calibrate**.
4. Select **2: Reset Calibration**.
5. Select **Restore Factory Calibration** or **Restore Site Calibration**.

SIMULATION

Sensor Output

Fast Keys	3, 6, 1
-----------	---------

The 2160 output state can be overridden by **Sensor Output**. The output state can be fixed to **Wet** or **Dry**.

To start the output state simulation:

1. From the *Home* screen, select **3: Service Tools**.
2. Select **6: Simulate**.
3. Select **1: Sensor Output Mode**.
4. Select 0.0 (for Dry) or 1.0 (for Wet).

This mode is cancelled by setting the mode to “Normal”, and is cleared by a power loss or reset.

Fork Frequency

Fast Keys	3, 6, 2
-----------	---------

The 2160 fork frequency can be overridden by Fork Frequency. The frequency can be set to a value in the range 0 to 3000 Hz.

To start the output state simulation:

1. From the *Home* screen, select **3: Service Tools**.
2. Select **6: Simulate**.
3. Select **2: Fork Frequency**.
4. Set the fork frequency.

This override is cancelled by setting the frequency to “Normal”, and is cleared by a power loss or reset.

ADVANCED FUNCTIONS FOR HART PROTOCOL

Saving, Recalling, and Cloning Configuration Data

Fast Keys	left arrow, 1, 2
-----------	------------------

Use the cloning feature of the Field Communicator or the AMS “User Configuration” feature to configure several wireless liquid level switches similarly. Cloning involves configuring a transmitter, saving the configuration data, then sending a copy of the data to a separate transmitter. Several possible procedures exist when saving, recalling, and cloning configuration data. For complete instructions refer to the Field Communicator manual (publication no. 00809-0100-4276) or AMS on-line guides. One common method is as follows:

Field Communicator

1. Completely configure the first transmitter.
2. Save the configuration data:
 - a. Select **F2 SAVE** from the Field Communicator **HOME/ONLINE** screen.
 - b. Ensure that the location to which the data will be saved is set to **MODULE**. If it is not, select **1: Location** to set the save location to **MODULE**.
 - c. Select **2: Name**, to name the configuration data. The default is the transmitter tag number.
 - d. Ensure that the data type is set to **STANDARD**. If the data type is **NOT STANDARD**, select **3: Data Type** to set the data type to **STANDARD**.
 - e. Select **F2 SAVE**.
3. Connect and power the receiving transmitter and Field Communicator.
4. Select the back arrow from the **HOME/ONLINE** screen. The Field Communicator menu appears.
5. Select **1: Offline, 2: Saved Configuration, 1: Module Contents** to reach the **MODULE CONTENTS** menu.
6. Use the **DOWN ARROW** to scroll through the list of configurations in the memory module, and use the **RIGHT ARROW** to select and retrieve the required configuration.
7. Select **1: Edit**.
8. Select **1: Mark All**.
9. Select **F2 SAVE**.
10. Use the **DOWN ARROW** to scroll through the list of configurations in the memory module, and use the **RIGHT ARROW** to select the configuration again.
11. Select **3: Send** to download the configuration to the transmitter.
12. Select **OK** after the control loop is set to manual.
13. After the configuration has been sent, select **OK** to acknowledge that the loop can be returned to automatic control.

When finished, the Field Communicator informs you of the status. Repeat Steps 3 through 13 to configure another transmitter.

NOTE

The transmitter receiving cloned data must have the same software version (or later) as the original transmitter.

AMS creating a Reusable Copy

To create a reusable copy of a configuration perform the following procedure:

1. Completely configure the first transmitter.
2. Select **View** then **User Configuration View** from the menu bar (or click the toolbar button).
3. In the *User Configuration* window, right click and select **New** from the context menu.
4. In the New window, select a device from the list of templates shown, and click **OK**.
5. The template is copied into the *User Configurations* window, with the tag name highlighted; rename it as appropriate and press **Enter**.

NOTE

A device icon can also be copied by dragging and dropping a device template or any other device icon from AMS Explorer or Device Connection View into the User Configurations window.

The “Compare Configurations” window appears, showing the Current values of the copied device on one side and mostly blank fields on the other (User Configuration) side.

6. Transfer values from the current configuration to the user configuration as appropriate or enter values by typing them into the available fields.
7. Click **Apply** to apply the values, or click **OK** to apply the values and close the window.

AMS Applying a User Configuration

Any amount of user configurations can be created for the application. They can also be saved, and applied to connected devices or to devices in the Device List or Plant Database.

To apply a user configuration perform the following procedure:

1. Select the desired user configuration in the *User Configurations* window.
2. Drag the icon onto a like device in AMS Explorer or Device Connection View. The *Compare Configurations* window opens, showing the parameters of the target device on one side and the parameters of the user configuration on the other.
3. Transfer parameters from the user configuration to the target device as desired, Click **OK** to apply the configuration and close the window.

Section 3 Installation

Safety Messages	page 3-1
Considerations	page 3-2
Installation Procedures	page 3-6

SAFETY MESSAGES

Procedures and instructions in this section may require special precautions to ensure the safety of the personnel performing the operation. Information that raises potential safety issues is indicated with a warning symbol (). Refer to the following safety messages before performing an operation preceded by this symbol.

Warnings

 WARNING

Failure to follow these installation guidelines could result in death or serious injury

- The Rosemount 2160 is a *wireless liquid level switch*. It must be installed, connected, commissioned, operated, and maintained by suitably qualified personnel only, observing any national and local requirements that may apply
- Use the equipment only as specified in this manual. Failure to do so may impair the protection provided by the equipment

Explosions could result in death or serious injury

- Installation of the 2160 in a hazardous environment must be in accordance with the appropriate local, national, and international standards, codes, and practices. Please review the approvals section of the 2160 Reference Manual for any restrictions associated with an installation
- Before connecting a Field Communicator in an explosive atmosphere, ensure the installation is in accordance with intrinsically safe or non-incendive field wiring practices
- Verify that the operating atmosphere of the level switch is consistent with the appropriate hazardous locations certifications

External Surface may be hot

- Care must be taken to avoid possible burns

Process leaks could result in death or serious injury

- Install and tighten process connectors before applying pressure
- Do not attempt to loosen or remove process connectors while the 2160 is in service

Electrical shock could cause death or serious injury

- If the liquid level switch is installed in a high voltage environment and a fault condition or installation error occurs, high voltage may be present on leads and terminals
- Use extreme caution when making contact with the leads and terminals
- Make sure that power to the 2160 is off while making connections

Rosemount 2160

CONSIDERATIONS

General Considerations

IMPORTANT

For material compatibility considerations, see document number 00816-0100-3045 on www.rosemount.com.

Wireless Considerations

Power Up Sequence

The power module should not be installed on any wireless device until the Smart Wireless Gateway (“Gateway”) is installed and is functioning properly. Wireless devices should also be powered up in order of proximity to the Gateway, beginning with the closest. This will result in a simpler and faster network installation. Enable Active Advertising on the Gateway to ensure that new devices join the network faster. For more information, see the Smart Wireless Gateway Manual (Document Number 00809-0200-4420).

Antenna Position

The antenna should be positioned vertically, either straight up or straight down, and it should be approximately 3 ft. (1 m) from any large structure, building, or conductive surface to allow for clear communication to other devices.

Environmental Considerations

The Rosemount 2160 is a wireless liquid level switch, and is Intrinsically Safe (IS) approved for hazardous area installations.

NOTE:

Approvals are listed in Section B of this reference manual.

This *wireless liquid level switch* is designed for open or closed tanks, and pipe installation. It is weatherproof and protected against the ingress of dust, but must be protected from flooding. Avoid installing the 2160 near heat sources.

Figure 3-1.
Environmental Considerations

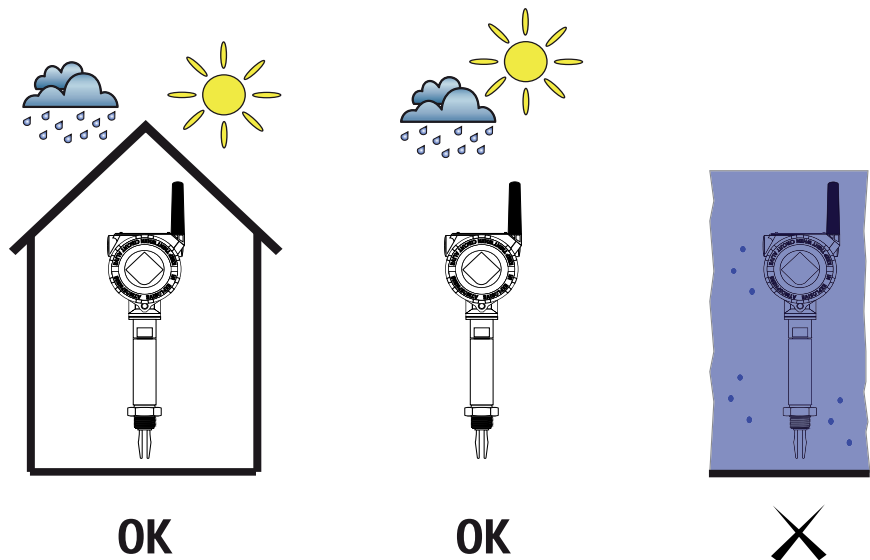

Installation Considerations

For dimensional drawings, see “Dimensional Drawings” on page A-6.

Battery Side of Electronics Housing

Mount the switch so that the battery side is accessible. Clearance of $2\frac{3}{8}$ in. (60 mm) is required for cover removal.

Circuit Side of Electronics Housing

Provide 0.75 in. (19 mm) of clearance for units without an LCD display. Three inches of clearance is required for cover removal if an LCD display is installed.

Cover Installation

Always ensure a proper seal by installing the electronics housing cover(s) so that metal contacts metal. Use Rosemount O-rings.

LCD Rotation

In addition to housing rotation, the optional LCD display can be rotated in 90° increments by squeezing the two tabs, pulling out, rotating and snapping back into place.

NOTE

If LCD pins are inadvertently removed from the interface board, carefully re-insert the pins before snapping the LCD display back into place.

Grounding

Always ground the housing in accordance with national and local electrical codes. The most effective grounding method for the housing is a direct connection to earth ground with minimal impedance.

Housing Rotation

The housing can be rotated for optimal viewing of the optional LCD display and to get the best antenna position. Perform the following procedure:

1. Loosen the housing rotation set screw (Figure 3-2).
2. First rotate the housing clockwise to the desired location. If the desired location cannot be achieved due to thread limit (up to 360°), rotate the housing counter-clockwise to the desired location. **Do not over twist.**
3. Re-tighten the housing rotation set screw.

Figure 3-2.
Housing Rotation Screw



Handling The 2160

Use both hands to carry the 2160***E and do not hold using the forks.

Figure 3-3. Handling The 2160

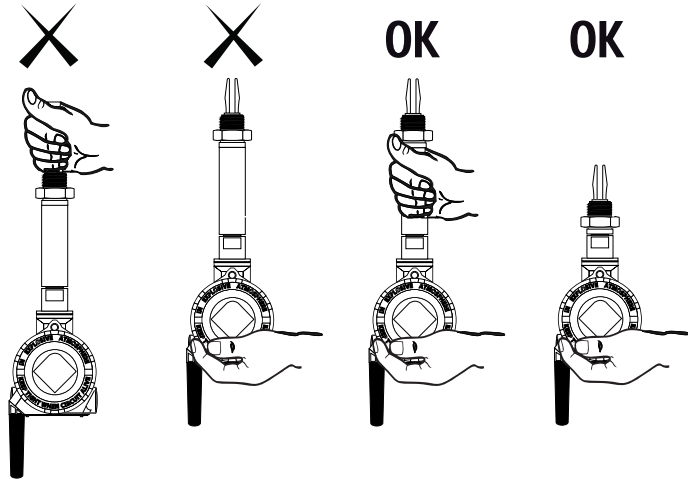
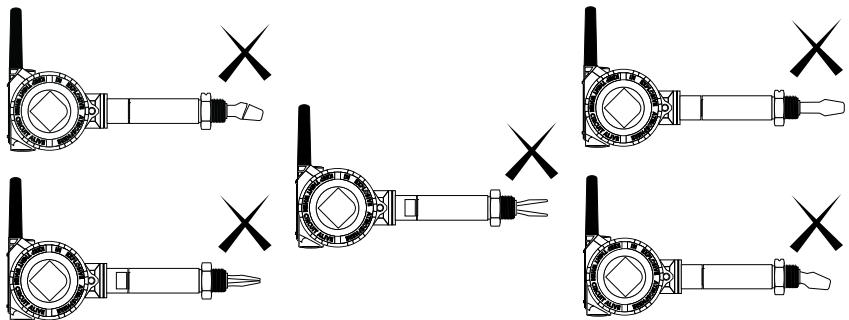

Figure 3-4. Do Not Alter The 2160

Do not alter the 2160 in any way.



Device Identification

See Appendix B: Product Certifications for device approvals.

Figure 3-5. Device Identification

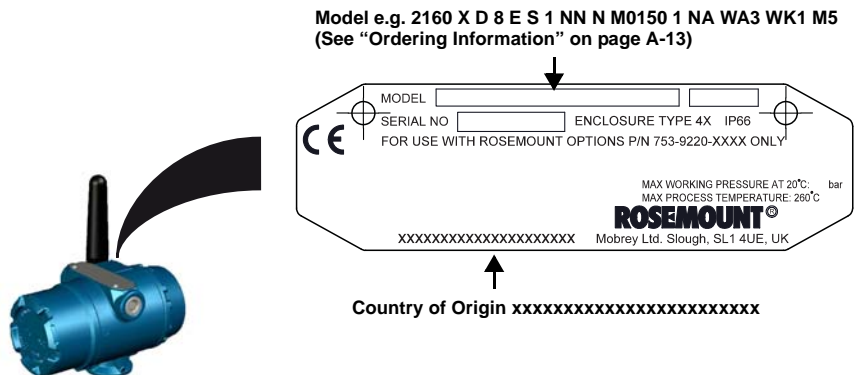

Recommendations

- Avoid installing near to liquid entering the tank at the fill point
- Avoid heavy splashing on the forks
Increasing the sensor output delay reduces accidental switching caused by splashing (see “Sensor Output Delay” on page 2-10).
- Ensure that the forks do not come into contact with the tank wall, any internal fittings, or obstructions
- Ensure there is sufficient distance between build-up on the tank wall and the fork (see Figure 1-2 on page 1-5)
- Ensure the installation does not create tank crevices around the forks where liquid may collect. This can happen with high-viscosity and high-density liquids
- Extra consideration is needed if the plant vibration is close to the 1400 Hz operating frequency of the 2160
- Supporting the fork avoids long fork length vibration

INSTALLATION PROCEDURES

Battery Installation

Figure 3-6.
Wireless Battery Installation

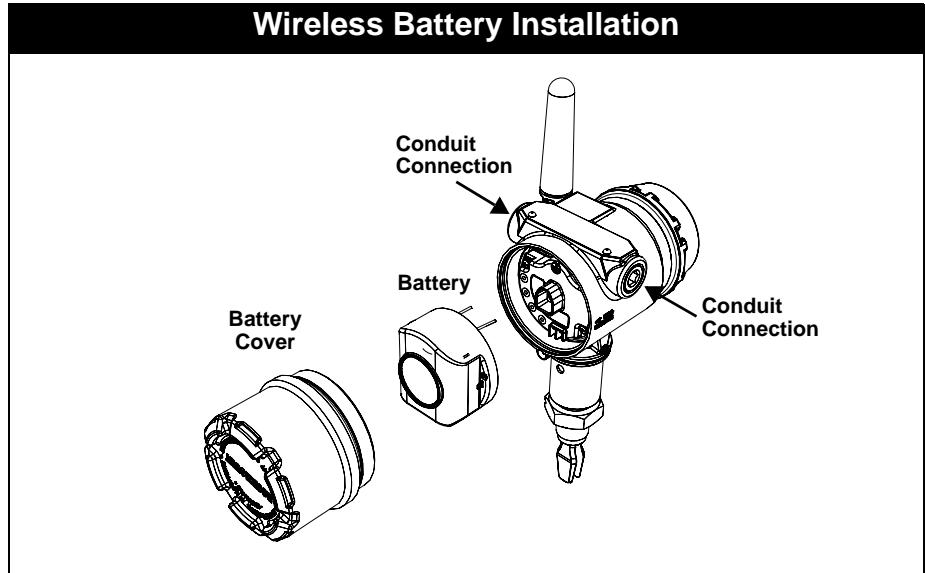

To install the battery, perform the following procedure:

- ⚠ 1. Remove the housing cover on the battery compartment side (Figure 3-6.)
The battery supplies all power to the 2160.
- 2. Connect the battery.
- 3. Replace the battery cover and tighten to safety specification
(metal-to-metal.)

Installing the LCD Display

Switches ordered with the LCD display are shipped with the display installed.

NOTE

An LCD from a *wired device* will not function in a *wireless device*.
Only use Rosemount Wireless LCD Part Number: 00753-9004-0002

In addition to housing rotation, the optional LCD display can be rotated in 90° increments by squeezing the two tabs, pulling out, rotating and snapping back into place.

If LCD pins are inadvertently removed from the interface board, carefully re-insert the pins before snapping the LCD display back into place.

Use the following procedure and Figure 3-7 to install the LCD display:

1. Remove the battery cover and battery (Figure 3-6.)
2. Remove the cover opposite the field terminal side. **Do not remove the covers in hazardous environments when the circuit is live.**
3. Engage the four-pin connector into the LCD display and snap into place.

Note the following LCD temperature limits:

- **Operating:** –40 to 175 °F (–20 to 80 °C)
- **Storage:** –40 to 185 °F (–40 to 85 °C)

Figure 3-7.
Optional LCD Display

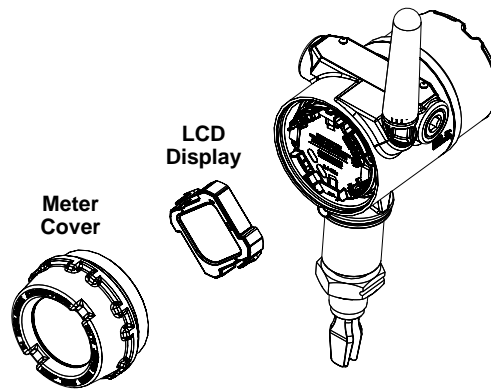

Mechanical

Sealing

Figure 3-8. Sealing

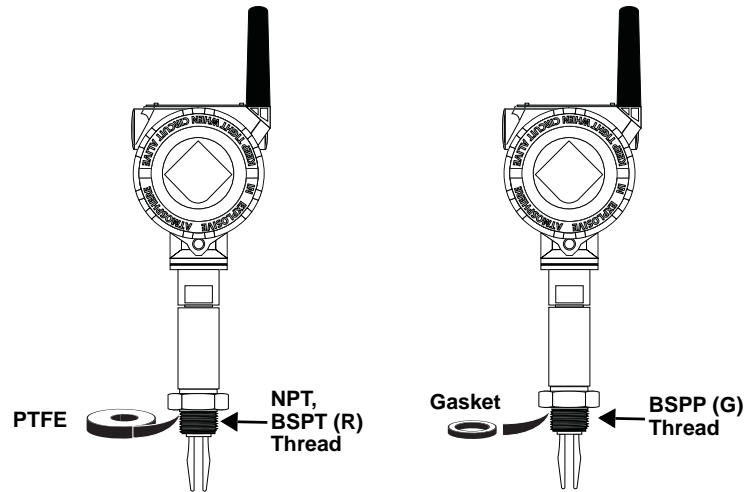

Correct Fork Alignment

Ensure the fork is correctly aligned by using the notches and grooves as indicated in Figure 3-9.

Figure 3-9.
Correct Fork Alignment

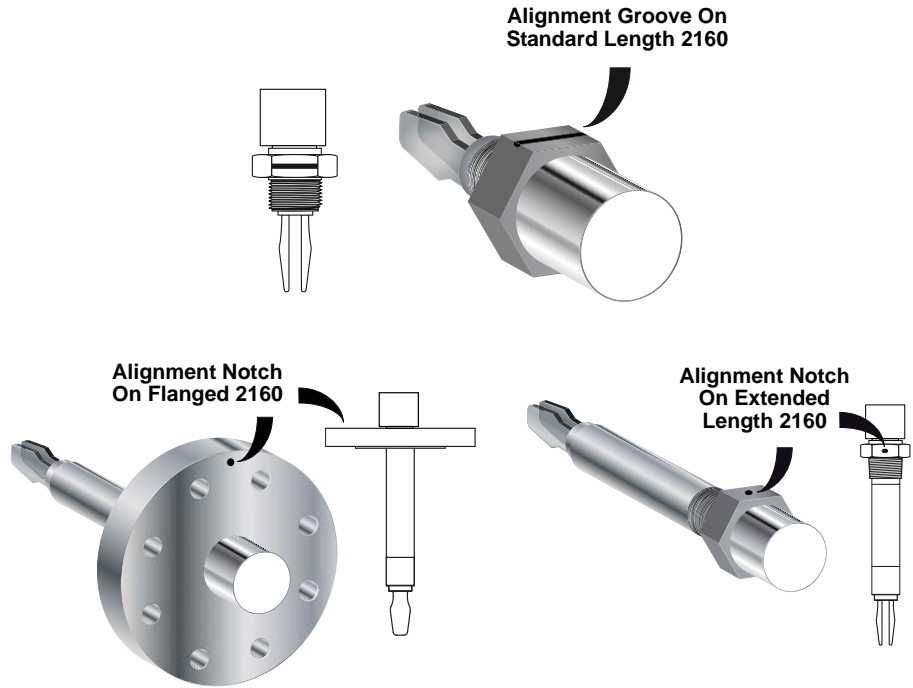

Pipe Installation

Figure 3-10. Pipe Installation

NOTE

The housing and antenna have been rotated for an optimal viewing position and strongest wireless signal. See "Housing Rotation" on page 3-3.

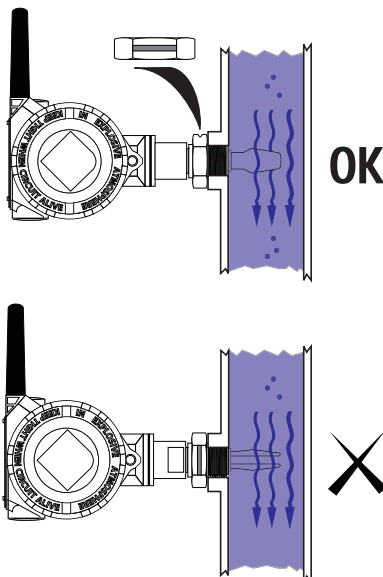

Tank Installation

Figure 3-11. Tank Installation

NOTE

The housing and antenna have been rotated for an optimal viewing position and strongest wireless signal. See "Housing Rotation" on page 3-3.

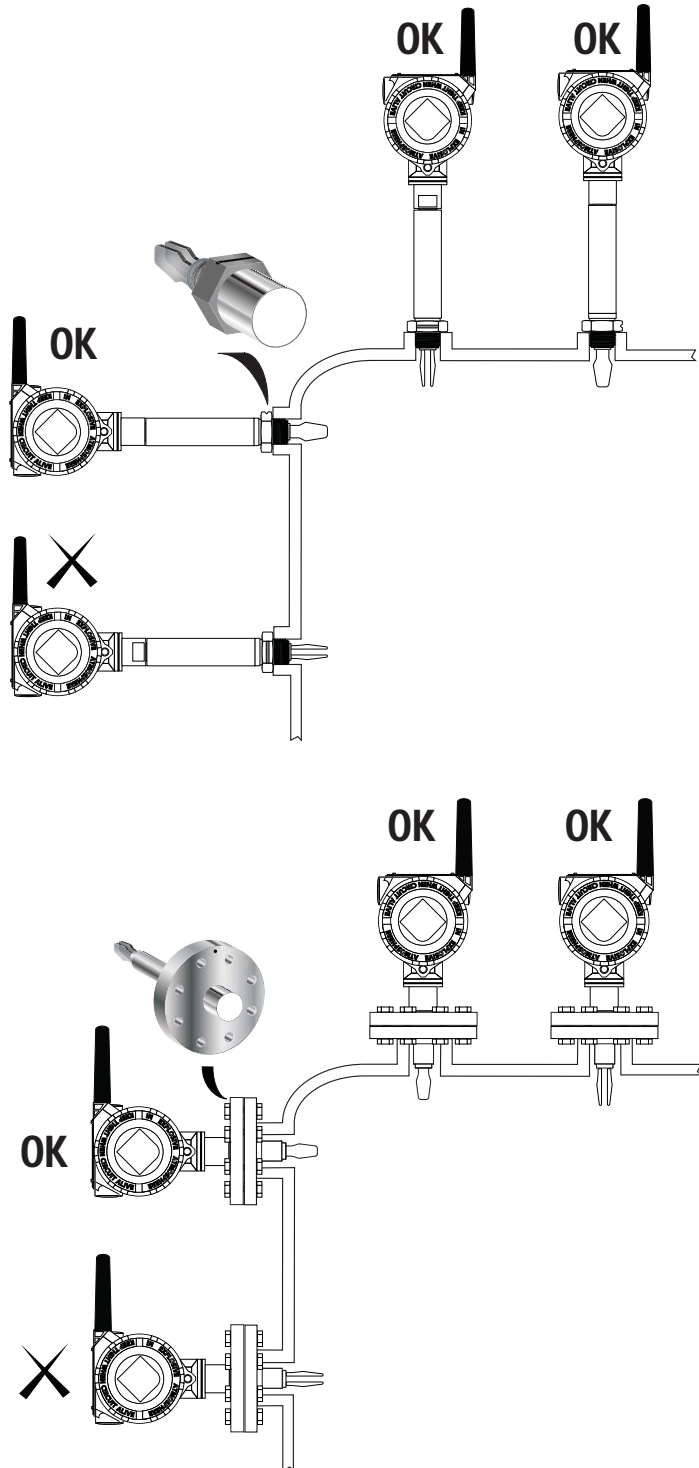
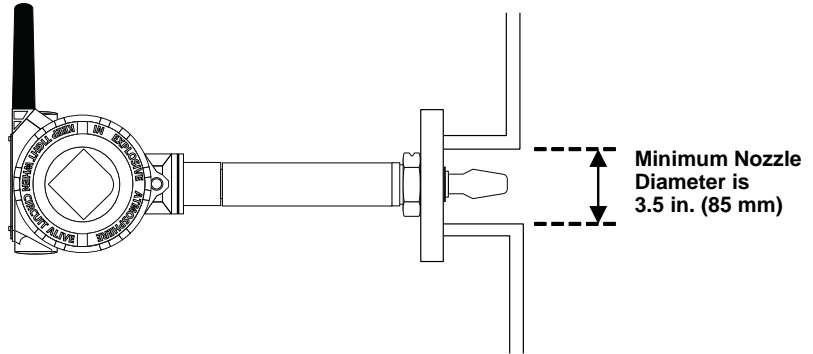

Figure 3-12.
Minimum Nozzle Diameter

NOTE

The housing and antenna have been rotated for an optimal viewing position and strongest wireless signal. See "Housing Rotation" on page 3-3.



Tightening the 2160

Figure 3-13.
Tightening the 2160

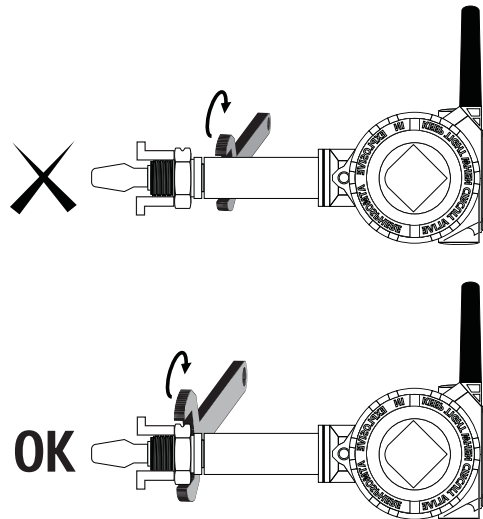

Insulation (2160***E Only)

Figure 3-14. Insulation

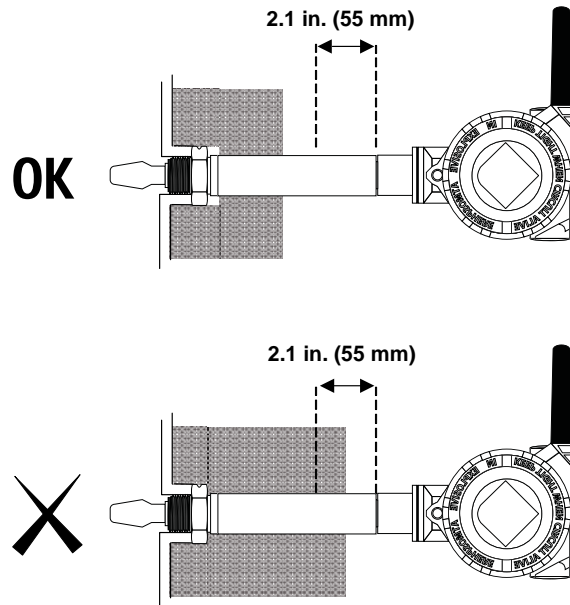

Operations

Figure 3-15. High Level Alarm

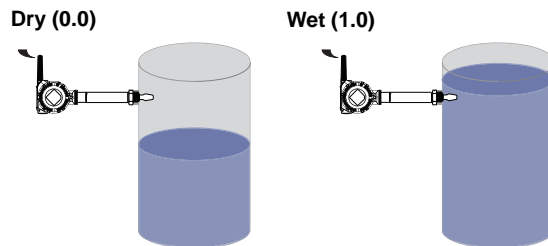

Figure 3-16. Low Level Alarm

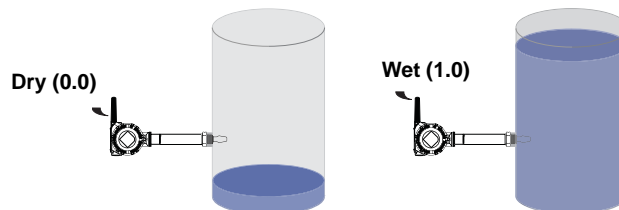

Figure 3-17. Overfill Protection

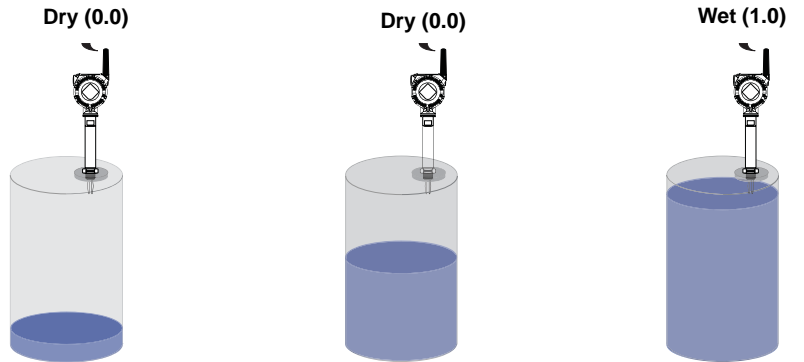

Figure 3-18. Pump Control

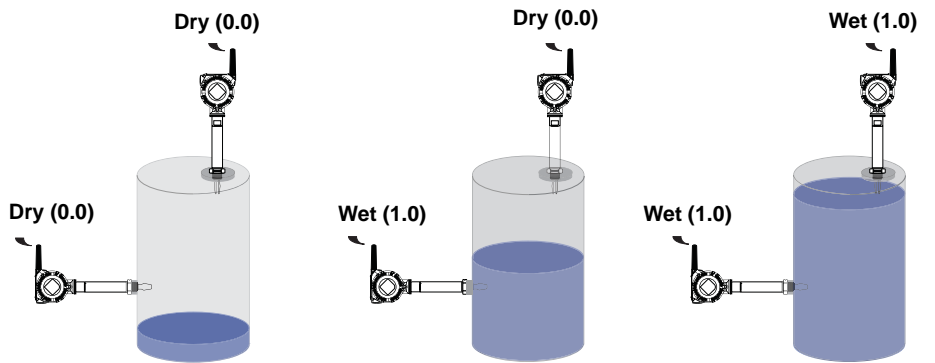
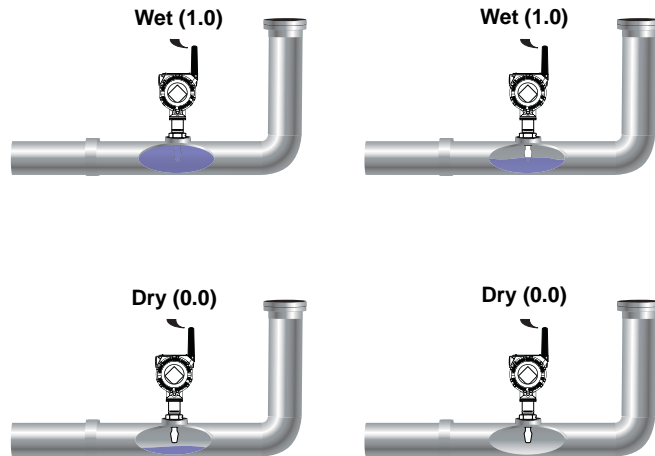

Figure 3-19. Pump or Empty Pipe Protection



Section 4 Commissioning

Safety Messages	page 4-1
Verify Operation	page 4-2
How to Use Squawk	page 4-4

SAFETY MESSAGES

Instructions and procedures in this section may require special precautions to ensure the safety of the personnel performing the operations. Information that potentially raises safety issues is indicated by a warning symbol (⚠). Please refer to the following safety messages before performing an operation preceded by this symbol.

Warnings

⚠ WARNING

Failure to follow these installation guidelines could result in death or serious injury

- The Rosemount 2160 is a *wireless liquid level switch*. It must be installed, connected, commissioned, operated, and maintained by suitably qualified personnel only, observing any national and local requirements that may apply
- Use the equipment only as specified in this manual. Failure to do so may impair the protection provided by the equipment

Explosions could result in death or serious injury

- Installation of the 2160 in a hazardous environment must be in accordance with the appropriate local, national, and international standards, codes, and practices. Please review the approvals section of the 2160 Reference Manual for any restrictions associated with an installation
- Before connecting a Field Communicator in an explosive atmosphere, ensure the installation is in accordance with intrinsically safe or non-incendive field wiring practices
- Verify that the operating atmosphere of the level switch is consistent with the appropriate hazardous locations certifications

External Surface may be hot

- Care must be taken to avoid possible burns

Process leaks could result in death or serious injury

- Install and tighten process connectors before applying pressure
- Do not attempt to loosen or remove process connectors while the 2160 is in service

Electrical shock could cause death or serious injury

- If the liquid level switch is installed in a high voltage environment and a fault condition or installation error occurs, high voltage may be present on leads and terminals
- Use extreme caution when making contact with the leads and terminals
- Make sure that power to the 2160 is off while making connections

NOTE

The Rosemount 2160 and all other wireless devices should be installed only after the Smart Wireless Gateway has been installed and is functioning properly. Wireless devices should also be powered up in order of proximity from the Gateway, beginning with the closest device to the Gateway. This will result in a simpler and faster network installation.

VERIFY OPERATION

Operation can be verified in four locations: at the device via the LCD, by using the Field Communicator, at the Smart Wireless Gateway's integrated web interface, or via AMS Wireless Configurator.

Troubleshooting





If the device is not joined to the network after power up, verify the correct configuration of the Network ID and Join Key, and verify the Active Advertising has been enabled on the Gateway. The Network ID and Join Key in the device must match the Network ID and Join Key of the Gateway.

The Network ID and Join Key may be obtained from the Gateway on the **Setup>Network>Settings** page on the web interface (see Figure 4-1 on page 4-3). The Network ID and Join Key may be changed in the wireless device by using the following Fast Key sequence.

Function	Key Sequence	Menu Items
Wireless	2, 1, 1	Join Device to Network

Local Display

The LCD displays the Primary Variable (PV) value at the configured update rate, but no faster than once every 60 seconds. See Network Diagnostic Status Screens on page 5-5 for error codes and other LCD messages. Press the **Diagnostic** button to display the **TAG, Device ID, Network ID, Network Status, and Device Status** screens.

Searching for Network	Joining Network	Connected with Limited Bandwidth	Connected
			

Field Communicator

A 2160 DD (Device Descriptor) is required for HART communication. For connecting with a Field Communicator, see Figure 2-1 on page 2-3.

Function	Key Sequence	Menu Items
Communications	3, 4	Join Status, Wireless Mode, Join Mode, Number of Available Neighbors, Number of Advertisements Heard, and Number of Join Attempts

Smart Wireless Gateway

In the integrated web interface from the Gateway, navigate to the **Explorer>Status** page. This page will show whether the device has joined the network and if it is communicating properly.

NOTE

The time to join the new device(s) to the network is dependent upon the number of devices being joined and the number of devices in the current network. For one device joining an existing network with multiple devices, it may take up to five minutes. It may take up to 60 minutes for multiple new devices to join the existing network.

NOTE

If the device joins the network and immediately has an alarm present, it is likely due to the 2160 configuration. Re-check the 2160 configuration (see Section 2: Configuration).

Figure 4-1. Smart Wireless Gateway Network Settings

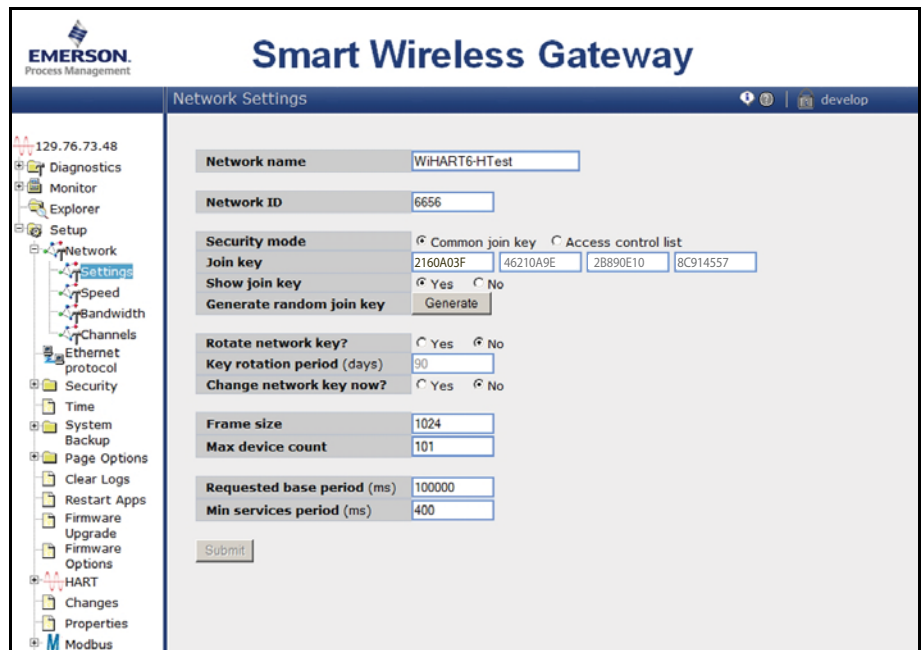

Rosemount 2160

AMS Wireless Configurator

When the device has joined the network, it will appear in the Device Manager as illustrated in Figure 4-2.

Figure 4-2.
AMS Wireless Configurator

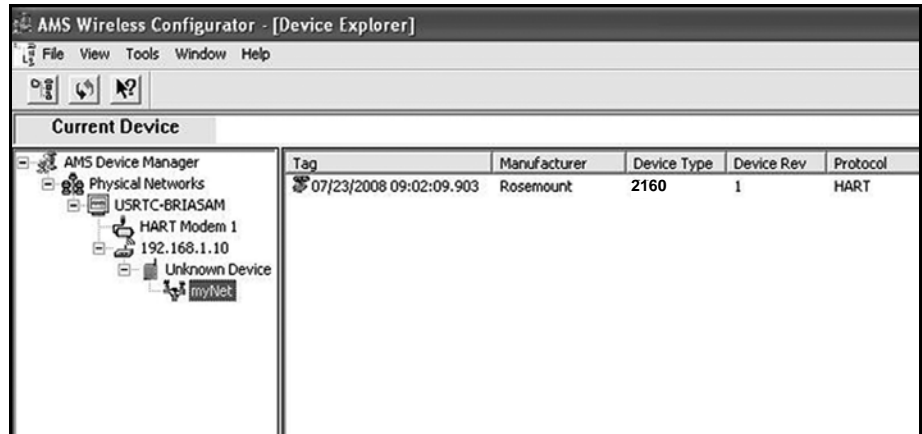

HOW TO USE SQUAWK



'Squawk' Pattern on the LCD Meter of a Located 2160

A feature called "Squawk" is available to **visually locate** an individual 2160 transmitter amongst multiple networked 2160 transmitters.

NOTE

The "Squawk" feature requires the 2160 to have the optional LCD meter fitted.

AMS Instructions

1. From the *AMS Device Manager*, select the **Tag** of a 2160 to be located.
2. Select **Service Tools** (on the left side of the Overview screen).
3. Select **Maintenance** (on the left side of the Service Tools screen).
4. Select **Routine Maintenance**.
5. Select **Locate Device** and then **Next** to activate Squawk.
6. Look for the pattern **0-0-0-0** on the LCD of the located 'squawking' 2160.
7. To de-activate Squawk, select **Next**, **Cancel**, **Next**, and finally **Finish**.

Field Communicator Instructions

1. From the *Home* screen, select **3: Service Tools**.
2. Select **5: Maintenance**.
3. Select **4: Routine Maintenance**.
4. Select **1: Locate Device**.
5. Follow on-screen instructions to activate Squawk.
6. Look for the pattern **0-0-0-0** on the LCD of the located 'squawking' 2160.
7. To de-activate Squawk, exit the feature.

NOTE

It can take up to 60 seconds for the 2160 to return to normal operations.

Section 5 Operation and Maintenance

Safety Messages	page 5-1
Inspection	page 5-2
Maintenance	page 5-2
LCD Screen Messages	page 5-3
Troubleshooting	page 5-10
Power Module Replacement	page 5-10

SAFETY MESSAGES

Instructions and procedures in this section may require special precautions to ensure the safety of the personnel performing the operations. Information that potentially raises safety issues is indicated by a warning symbol (⚠). Please refer to the following safety messages before performing an operation preceded by this symbol.

Warnings

⚠ WARNING

Failure to follow these installation guidelines could result in death or serious injury

- The Rosemount 2160 is a *wireless liquid level switch*. It must be installed, connected, commissioned, operated, and maintained by suitably qualified personnel only, observing any national and local requirements that may apply
- Use the equipment only as specified in this manual. Failure to do so may impair the protection provided by the equipment

Explosions could result in death or serious injury

- Installation of the 2160 in a hazardous environment must be in accordance with the appropriate local, national, and international standards, codes, and practices. Please review the approvals section of the 2160 Reference Manual for any restrictions associated with an installation
- Before connecting a Field Communicator in an explosive atmosphere, ensure the installation is in accordance with intrinsically safe or non-incendive field wiring practices
- Verify that the operating atmosphere of the level switch is consistent with the appropriate hazardous locations certifications

External Surface may be hot

- Care must be taken to avoid possible burns

Process leaks could result in death or serious injury

- Install and tighten process connectors before applying pressure
- Do not attempt to loosen or remove process connectors while the 2160 is in service

Electrical shock could cause death or serious injury

- If the liquid level switch is installed in a high voltage environment and a fault condition or installation error occurs, high voltage may be present on leads and terminals
- Use extreme caution when making contact with the leads and terminals
- Make sure that power to the 2160 is off while making connections

Rosemount 2160

INSPECTION

- Visually examine the 2160 for damage. If it is damaged, do not use.
- Ensure the covers, blanking plugs, and antenna are fitted securely

Figure 5-1.
Inspect the 2160 for Damage

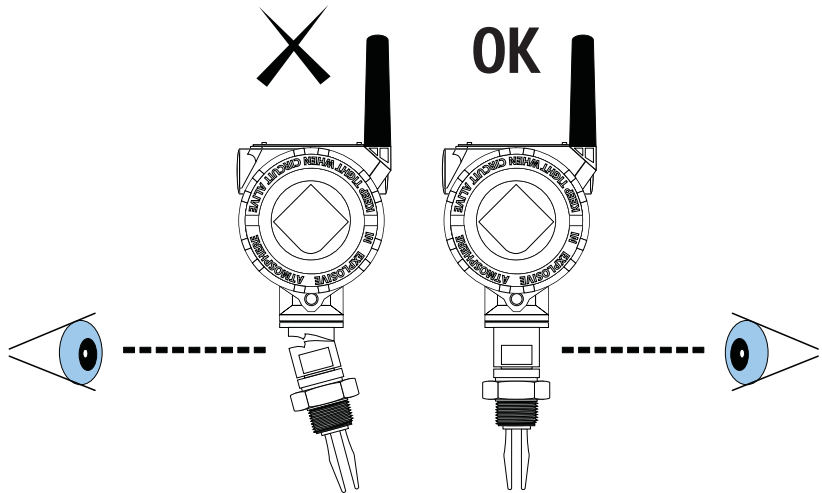

MAINTENANCE

NOTE:

Only use a soft brush to clean the 2160. Use great care when cleaning the forks.

Figure 5-2.
Maintenance of the 2160

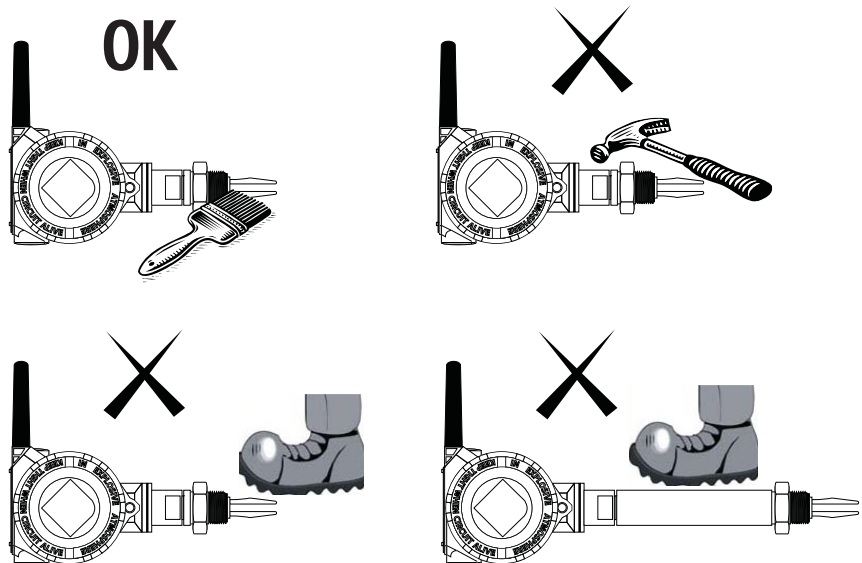

**LCD SCREEN
MESSAGES**

**Startup Screen
Sequence**

The following screens will display when the battery is first connected to the Rosemount 2160.

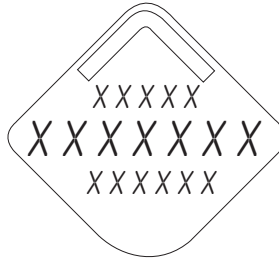

All Segments On: used to visually determine if there are any bad segments on the LCD

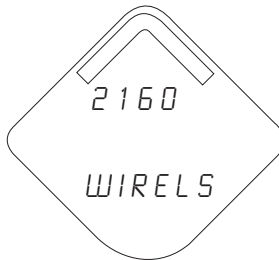

Device Identification: used to determine Device Type.

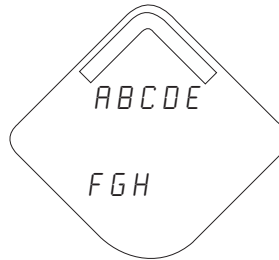

Device Information - Tag: user entered tag which is 8 characters long - will not display if all characters are blank

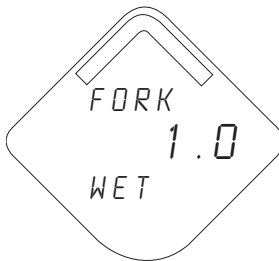

PV Screen - Fork (Switch) State

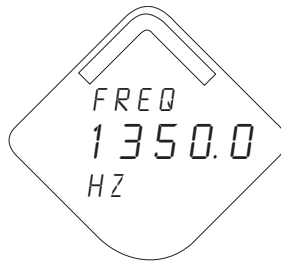

SV Screen - fork (switch) frequency

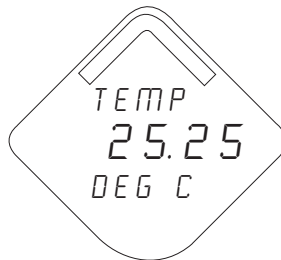

TV Screen - feature board temperature value

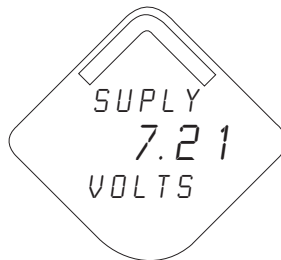

QV Screen - battery voltage

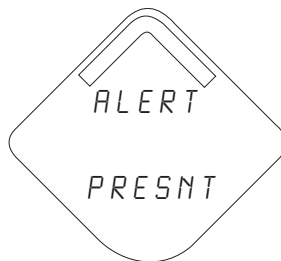

Alert Screen - at least one alert is present - this screen will not display if no alerts are present

**Diagnostic Button
Screen Sequence**

The following five screens will display when the device is operating properly and the Diagnostic Button has been pressed.

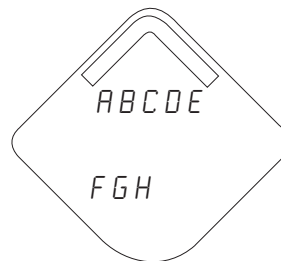

Device Information - Tag: user entered tag which is 8 characters long - will not display if all characters are blank

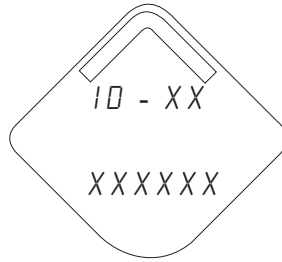

Device Identification: used to determine Device ID

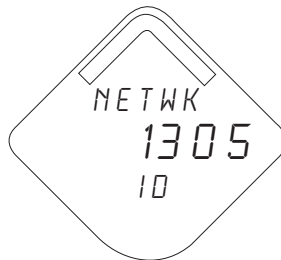

Diagnostic Button Screen 3: assuming the device has the correct join key, this ID tells the user what network the device can connect with



Diagnostic Button Screen 4.11: the device has joined a network and has been fully configured and has multiple parents

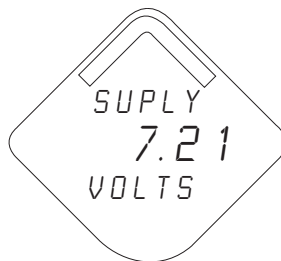

Diagnostic Button Screen 5: voltage reading at the power supply terminals

Network Diagnostic Status Screens

These screens display the network status of the device. Only one will be shown during the startup sequence or diagnostic sequence.

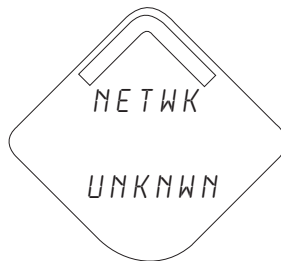

Diagnostic Button Screen 4.1: the device has yet to retrieve the information from the Rosemount 1420 Wireless Gateway and is still in the process of being activated

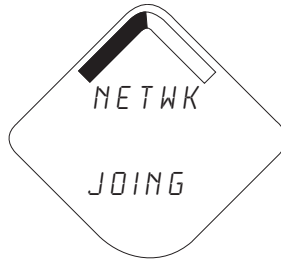

Diagnostic Button Screen 4.3: the device has sent JOIN request and is waiting for the ACTIVATE command

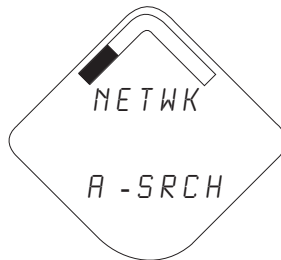

Diagnostic Button Screen 4.4: the device is in active search

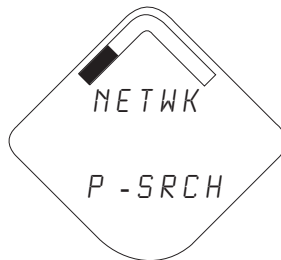

Diagnostic Button Screen 4.5: the device is in passive search



Diagnostic Button Screen 4.6: the device couldn't find the network and is in deep sleep mode to preserve battery power

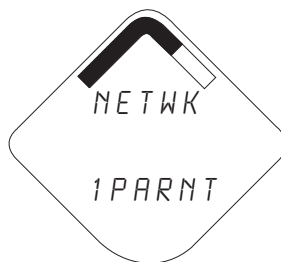

Diagnostic Button Screen 4.10: the device has joined a network and has been fully configured but has only 1 parent device

Device Diagnostic Screens

The following screens will show the device diagnostics depending on the state of the device.

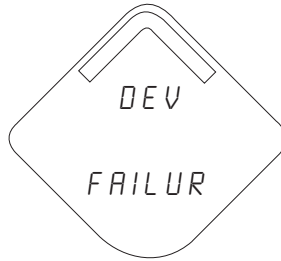

Device Information - Status: there is a critical error which may prevent the device from operating correctly. Check additional status screens for more information.

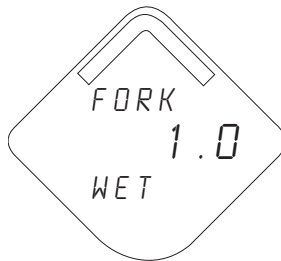

PV Screen - fork (switch) state

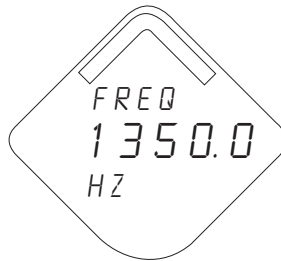

SV Screen - fork (switch) frequency

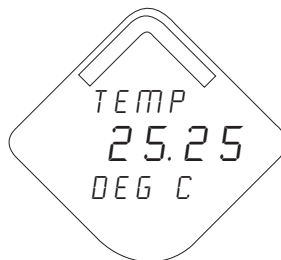

TV Screen - feature board temperature value

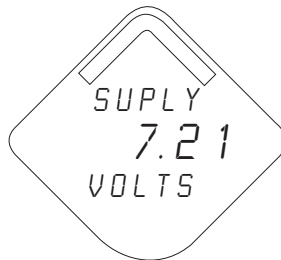

QV Screen - battery voltage

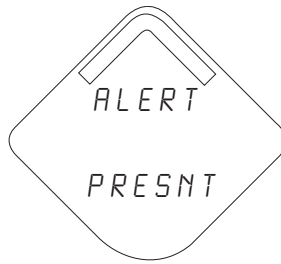

Alert Screen - at least one alert is present - this screen will not display if no alerts are present

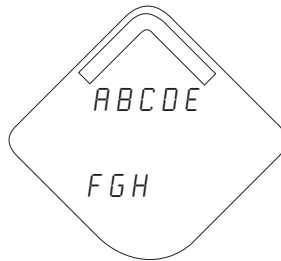

Diagnostic Button Screen 1 - Tag: user entered tag which is 8 characters long - will not display if all characters are blank

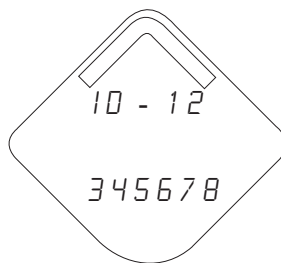

Diagnostic Button Screen 2: the device's identifier that is used to make up the HART long address - the Rosemount 1420 Wireless Gateway may use this to help identify devices if no unique user tag is available

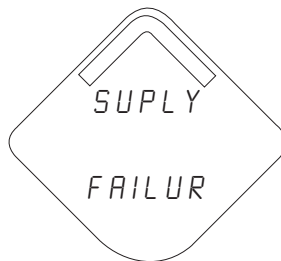

Diagnostic Button Screen 7.1: the terminal voltage has dropped below level of operating limit. Replace the battery
(Part Number: 00753-9220-0001)

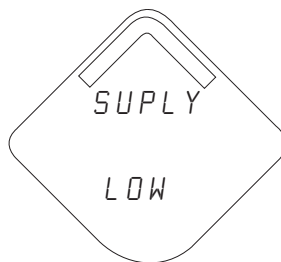

Diagnostic Button Screen 7.2: the terminal voltage is below the recommended operating range - if this is a battery operated device, the battery should be replaced - for line powered devices, the supply voltage should be increased

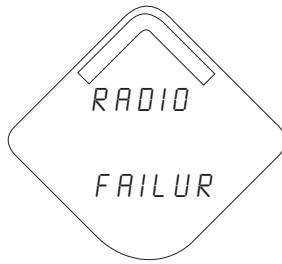

Diagnostic Button Screen 8: the device cannot retrieve information from the radio in the device - the device may still be operational and publishing HART data

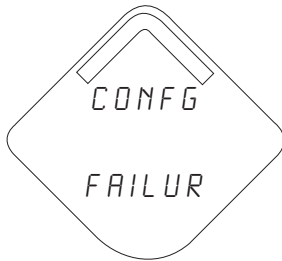

Diagnostic Button Screen 9.1: configuration of the transmitter is invalid such that critical operation of the device may be affected - check the extended configuration status to identify which configuration item(s) need to be corrected

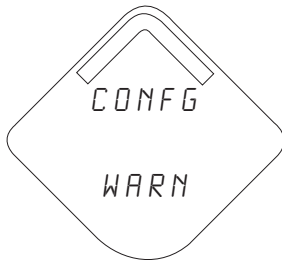

Diagnostic Button Screen 9.2: configuration of the transmitter is invalid such that non-critical operation of the device may be affected - check the extended configuration status to identify which configuration item(s) need to be corrected

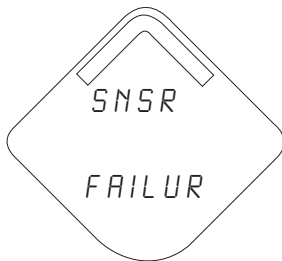

Diagnostic Button Screen 10.1: a sensor attached to the liquid level switch has failed, and valid readings from that sensor are no longer possible - check the sensor and sensor wiring connections - check additional status for more detailed information of the failure source

NOTE
Use the Rosemount Wireless LCD Part Number: 00753-9004-0002.

Rosemount 2160

TROUBLESHOOTING

See Table 5-1 for the Rosemount 2160 troubleshooting table.

Table 5-1. Rosemount 2160 troubleshooting table

Symptom	Corrective Actions
LCD is not functioning	<ul style="list-style-type: none"> • Re-seat the LCD according to Installing the LCD Display on page 3-7 • Verify that the LCD is a wireless LCD (Rosemount part number: 00753-9004-0002). An LCD from a wired device will not function in a wireless device • Verify that the LCD display mode is not disabled (Fast Key sequence 2, 2, 5, 1)
Does not switch output state	<ul style="list-style-type: none"> • There is no power – check the battery is installed correctly. Try another battery. • Fork is damaged – replace the 2160 • Thick encrustation on the forks – clean the fork with care
Incorrect switching of output state	<ul style="list-style-type: none"> • Check the configuration of frequency bands (See Dry Fork Frequency / Switch Points on page 2-19)
Faulty switching of output state	<ul style="list-style-type: none"> • Turbulence – set a longer switching time delay (See Sensor Output Delay on page 2-10) • Excessive electrical noise – suppress the cause of the interference

POWER MODULE REPLACEMENT

Expected power module life is ten years at reference conditions.⁽¹⁾

When the power module needs to be replaced, remove the power module cover and the power module (Part Number 00753-9220-001), and then replace the cover. Tighten to safety specification and verify operation.

Handling Considerations

The power module with the wireless unit contains two “C” size primary lithium/thionyl chloride batteries. Each battery contains approximately 2.5 grams of lithium, for a total of 5 grams in each back. Under normal conditions, the battery materials are self-contained and are not reactive as long as the batteries and the battery pack integrity are maintained. Care should be taken to prevent thermal, electrical, or mechanical damage. Contacts should be protected to prevent premature discharge.

Use caution when handling the power module. It may be damaged if dropped from heights in excess of 20 ft.

 Battery hazards remain when cells are discharged.

Environmental Considerations

As with any battery, local environmental rules and regulations should be consulted for proper management of spent batteries. If no specific requirements exist, recycling through a qualified recycler is encouraged. Consult the materials safety data sheet for battery specific information.

Shipping Considerations

The unit was shipped to you without the power module installed. Please remove the power module prior to shipping.

⁽¹⁾ Reference conditions are 70 °F (21 °C), transit rate of once per minute, and routing data for three additional network devices.

Each power module contains two “C” size primary lithium batteries. These batteries are regulated in transportation by the U. S. Department of Transportation, and are also covered by IATA (International Air Transport Association), ICAO (International Civil Aviation Organization), and ARD (European Ground Transportation of Dangerous Goods). It is the responsibility of the shipper to ensure compliance with these or any other local requirements. Please consult current regulations and requirements before shipping.

Appendix A Specifications and Reference Data

Specifications	page A-1
Dimensional Drawings	page A-6
Ordering Information	page A-13

SPECIFICATIONS

Physical

Product

The Rosemount 2160 Wireless Vibrating Fork Liquid Level Switch

Measuring Principle

Vibrating Fork

Applications

Most liquids including coating liquids, aerated liquids, and slurries.

Mechanical

Enclosure

Housing: Low-copper aluminum

Paint: Polyurethane

Cover O-ring: Nitrile butadiene

Terminal Block and Power Module Pack

PBT

Antenna

PBT/PC integrated omnidirectional antenna

Process Connection

Threaded Connection:

R 3/4 in. and 1 in. (BSPT); G 3/4 in. and 1 in. (BSPP); 3/4 in. and 1 in. NPT.

Material: 316/316L SST (1.4401/1.4404) dual certified, or Alloy C and Alloy C-276.

Accessories:

A stainless steel adjustable clamp gland is available for use with the extended length 2160 (1-in. models only). This clamp gland has a 1 1/2-in. BSPP or NPT thread to connect to the tank or pipe, and allows a 1-in. extended length 2160 to be raised or lowered, and clamped into position. See "Spare Parts and Accessories" on page A-15.

Flanged Connection:

ASME B16.5 (1-in. or larger) or EN 1092-1 (DN25 or larger)

Material: 316/316L SST (1.4401/1.4404) dual certified, or Alloy C and Alloy C-276



Hygienic Connection (Fitting):

1½-in. (38 mm) or 2-in. (51 mm) Tri-Clamp, or 1-in. BSPP (G) O-ring seal.

Material:

316/316L SST (1.4401/1.4404) dual certified.

Gasket material for ¾-in. and 1-in. BSPP (G) O-ring seal is non-asbestos BS7531 Grade X carbon fiber with rubber binder.

Options:

Hand polished wetside to a finish better than 0.4 µm.

Accessories:

A mounting kit comprising a fitting, Nitrile seal and clamp ring is available for use with the 2-in. (51 mm) Tri-Clamp version of the 2160.

A fitting boss with Fluorocarbon (FPM/FKM) O-ring is available for use with the O-ring seal version of the 2160.

See “Spare Parts and Accessories” on page 15.

Fork Length

Short fork for minimum intrusion installation. The minimum length is 2 in.

Extended Lengths

Table A-1. Minimum Extended Lengths

Process Connection	Minimum Extended Length
¾-in. Threaded	3.8 in. (95 mm)
1-in. Threaded	3.7 in. (94 mm)
Flanged	3.5 in. (89 mm)
Tri-Clamp	4.1 in. (105 mm)

The maximum extended length is 118.1 in. (3000 mm) except for:

- Hand-polished process (maximum length is 39.4 in. / 1000 mm)

Dimensional Drawings

See “Dimensional Drawings” on page A-6.

Mounting

Suitable for horizontal and vertical installations.

Rotatable housing allows correct alignment of both the forks and the omnidirectional antenna for optimal signal and best viewing position of the LCD integral display.

Enclosure Ratings

Housing is NEMA 4X and IP66 compliant.

Electrical

Wireless Power Module

Replaceable, Intrinsically Safe Lithium-Thionyl Chloride power module with PBT enclosure.

Ten year life at one minute transmit rate ⁽¹⁾

(1) Reference conditions are 70 °F (21 °C), and routing data for three additional network devices. NOTE: Continuous exposure to ambient temperature limits (–40 °F or 185 °F) (–40 °C or 85 °C) may reduce specified power module life by 20 percent.

HART Communicator Connections

Clips permanently fixed to terminal block

Performance

Electromagnetic Compatibility (EMC)

All models meet all relevant requirements of EN 61326.

Hysteresis (Water)

±0.039 in. (±1 mm) nominal

Switching Point (Water)

0.5 in. (13 mm) from fork tip if mounted vertically.

0.5 in. (13 mm) from the fork edge if mounted horizontally.

The switch point varies with different liquid densities.

Functional

Output

IEC 62591 (WirelessHART) 2.4 GHz DSSS

Radio Frequency Power Output from Antenna

Maximum of 10 mW (10 dBm) EIRP

Local Display

The optional five-digit integral LCD display can indicate the switch state (Dry or Wet) and diagnostic information.

Humidity Limits

0 to 100% relative humidity

Wireless Update Rate

User-selectable: from 1 second up to 60 minutes.

The optional integral LCD display updates at the wireless update rate.

Operating Modes

Table A-2. Operating Modes

Fault Conditions Detected	Normal Mode	Enhanced Mode
PCB Control Circuit Corruption	Yes	Yes
External Damage to Fork	No	Yes
Internal Damage to Sensor	No	Yes
Excessive Corrosion	No	Yes
Over-temperature	No	Yes

Maximum Operating Pressure

Threaded connection: See Figure A-1

Hygienic connection: 435 psig (30 bar g)

Flanged connection: The maximum operating pressure is the lower of the process pressure (Figure A-1) and flange pressure rating (Table A-3).

NOTE

The final maximum operating pressure rating depends on the process (tank) connection. Clamp glands (order #02120-2000-0001 or 02120-2000-0002) limit the maximum operating pressure to 18.85 psig (1.3 bar g).

Figure A-1. Process Pressure

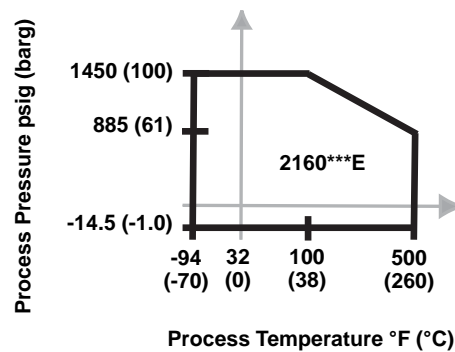
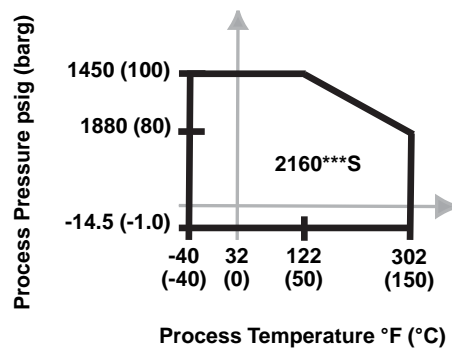

Table A-3. Maximum Flange Pressure Rating

Flange Standard	SST Flanges ⁽¹⁾
ASME B16.5 Class 150	275 psig ⁽²⁾
ASME B16.5 Class 300	720 psig ⁽²⁾
ASME B16.5 Class 600	1,440 psig ⁽²⁾
EN1092-1 PN 10	10 bar g ⁽³⁾
EN1092-1 PN 16	16 bar g ⁽³⁾
EN1092-1 PN 25	25 bar g ⁽³⁾
EN1092-1 PN 40	40 bar g ⁽³⁾
EN1092-1 PN 63	63 bar g ⁽³⁾
EN1092-1 PN 100	100 bar g ⁽³⁾

(1) ASTM stainless steel.

(2) At 100 °F (38 °C), the pressure rating decreases with an increasing process temperature.

(3) At 122 °F (50 °C), the pressure rating decreases with an increasing process temperature.

Temperature

See Figure A-2 for the maximum and minimum operating temperatures.

Figure A-2. Temperature

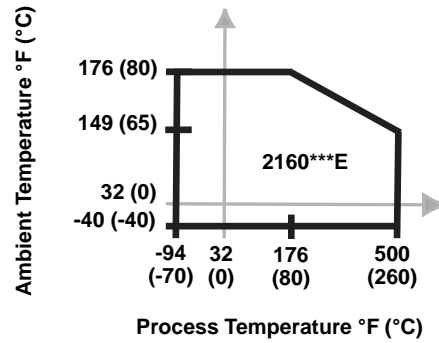
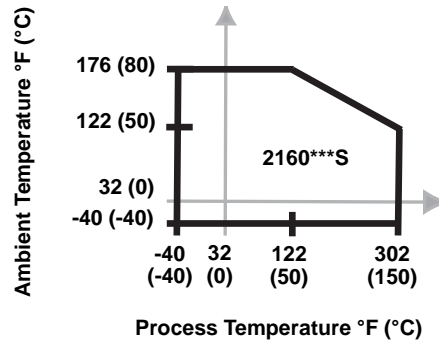

Liquid Density Range

Minimum liquid density is 31.2 lb/ft³ (500 kg/m³).

Liquid Viscosity Range

0.2 to 10000 cP (centiPoise).

Solids Content and Coating

The maximum recommended diameter of solid particles in the liquid is 0.2 in. (5 mm).
For coating products, avoid bridging of forks (fork-to-fork).

CIP (Clean In Place) Cleaning

The Rosemount 2160 withstands steam cleaning.

Rosemount 2160

DIMENSIONAL DRAWINGS

2160 Thread Mounting (Standard Length)	page A-6
2160 Thread Mounting (Extended Length)	page A-7
2160 Flange Mounting (Standard Length)	page A-8
2160 Flange Mounting (Extended Length)	page A-9
2160 Hygienic Fitting (Standard Length)	page A-10
2160 Hygienic Fitting (Extended Length)	page A-12

2160 Thread Mounting (Standard Length)

Note: Dimensions are in inches (millimeters)

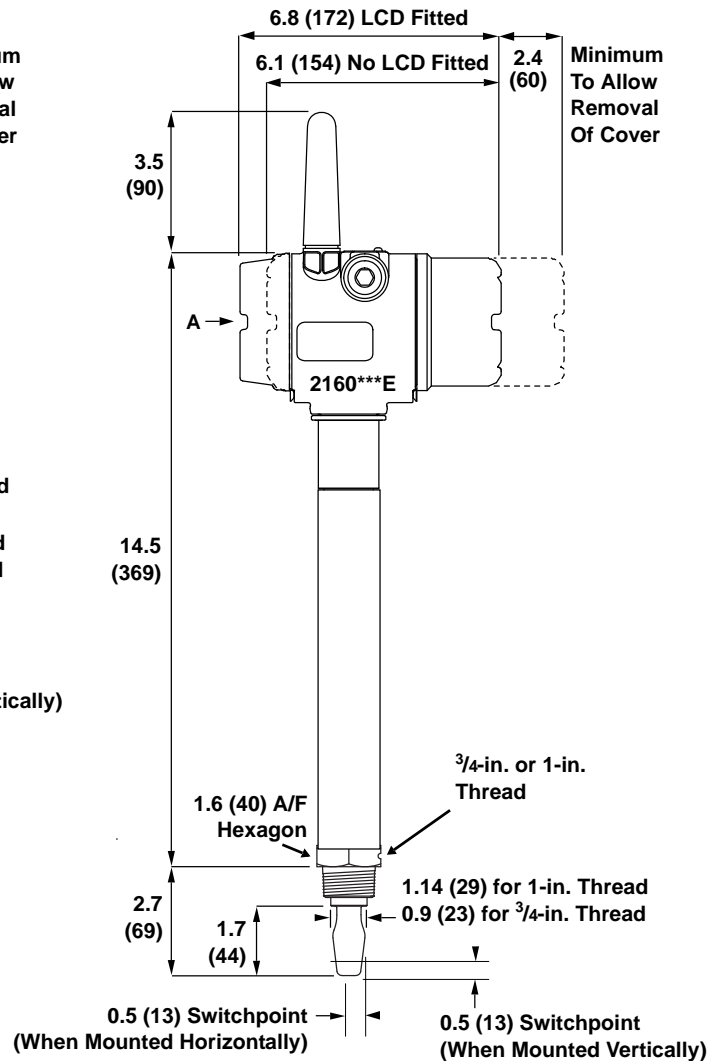
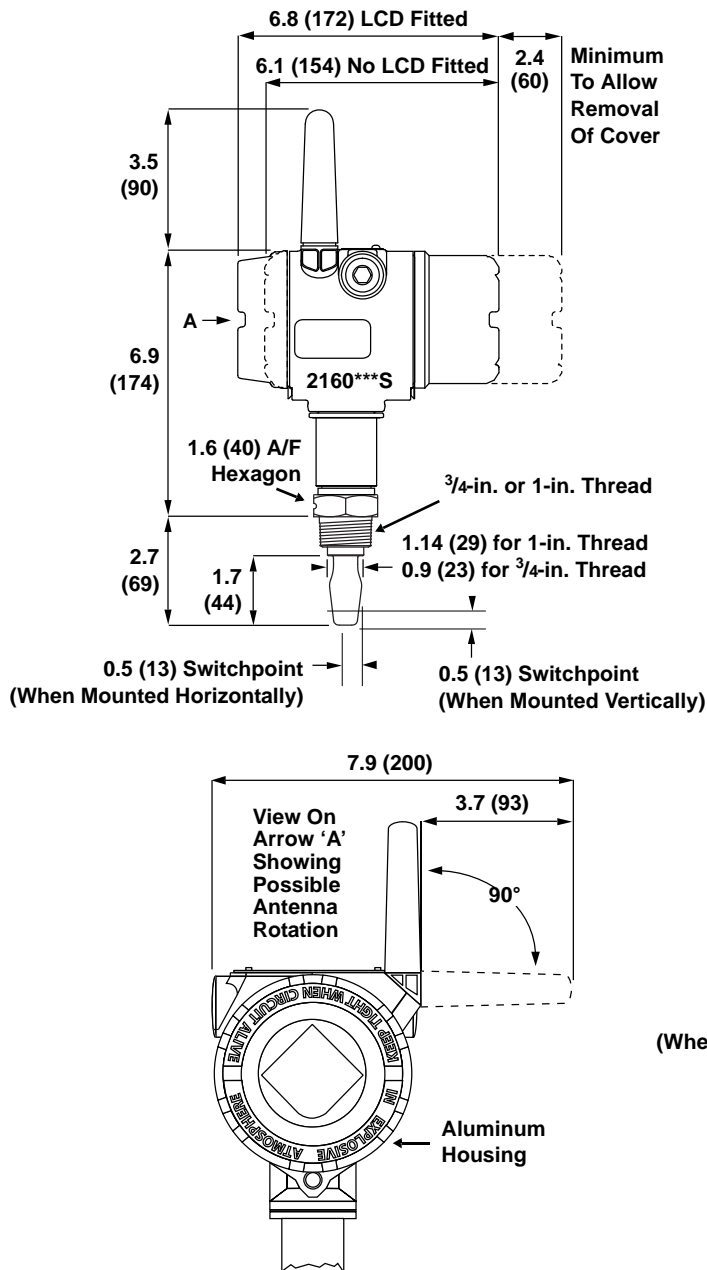

2160 Thread Mounting (Extended Length)

Note: Dimensions are in inches (millimeters)

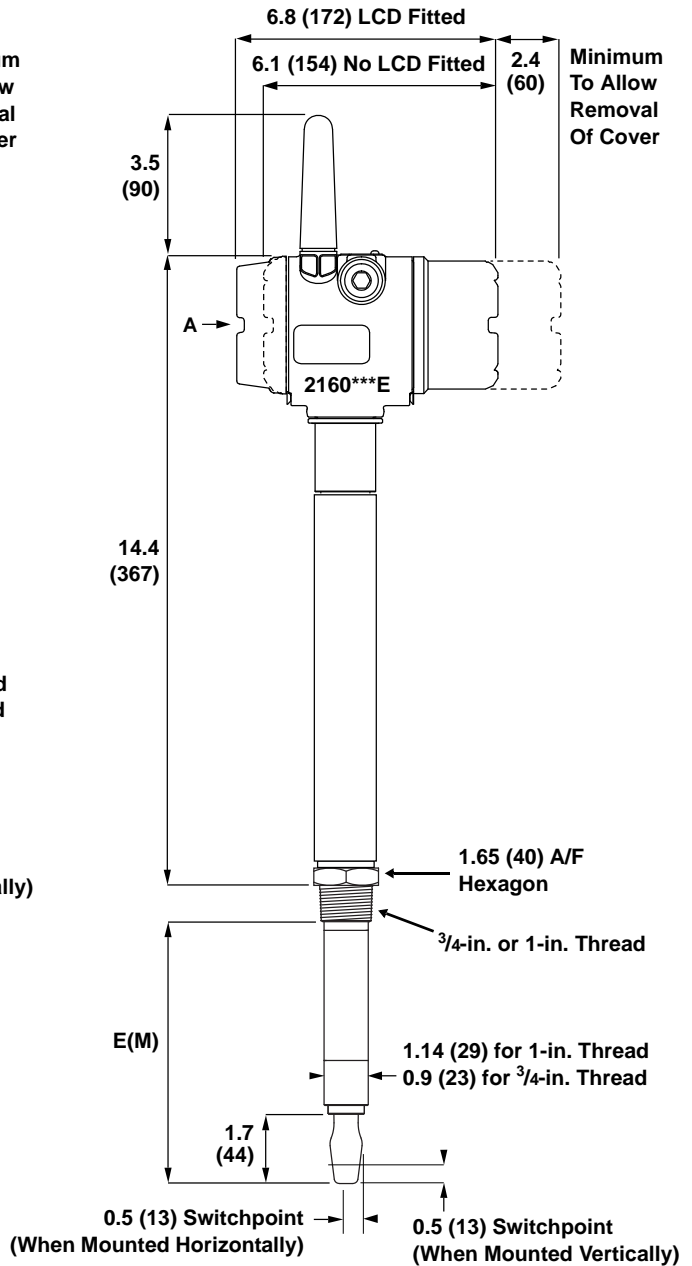
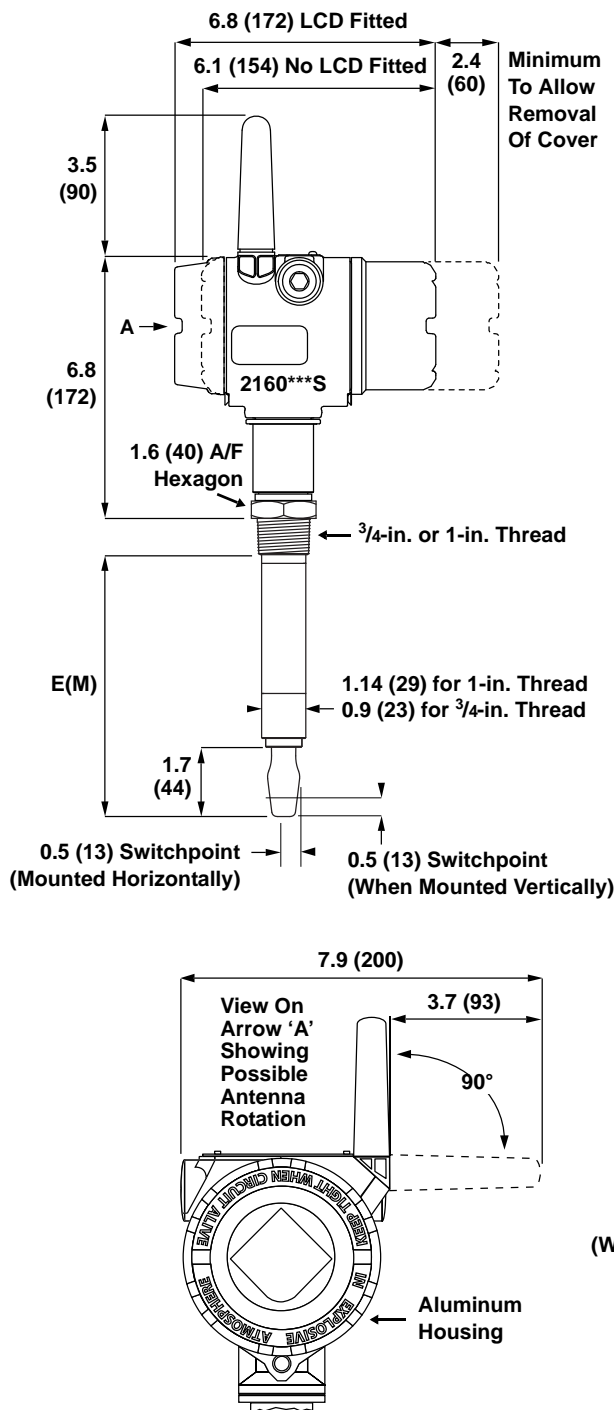

Table A-4. Thread Mounting Fork Length

Process Connection	Standard Length Model Code A	Minimum Length Model Code E (M)	Maximum Length Model Code E (M) ⁽¹⁾
3/4-in. Thread	1.73 in. (44 mm)	3.75 in. (95 mm)	118.1 in. (3000 mm)
1-in. Thread	1.73 in. (44 mm)	3.74 in. (94 mm)	118.1 in. (3000 mm)

(1) Maximum extended length of fork with hand-polished option is 39.4 in. (1000 mm).

2160 Flange Mounting (Standard Length)

Note: Dimensions are in inches (millimeters)

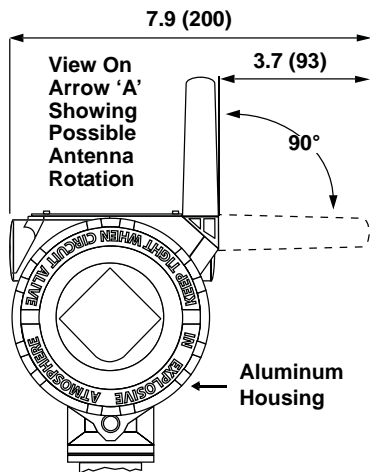
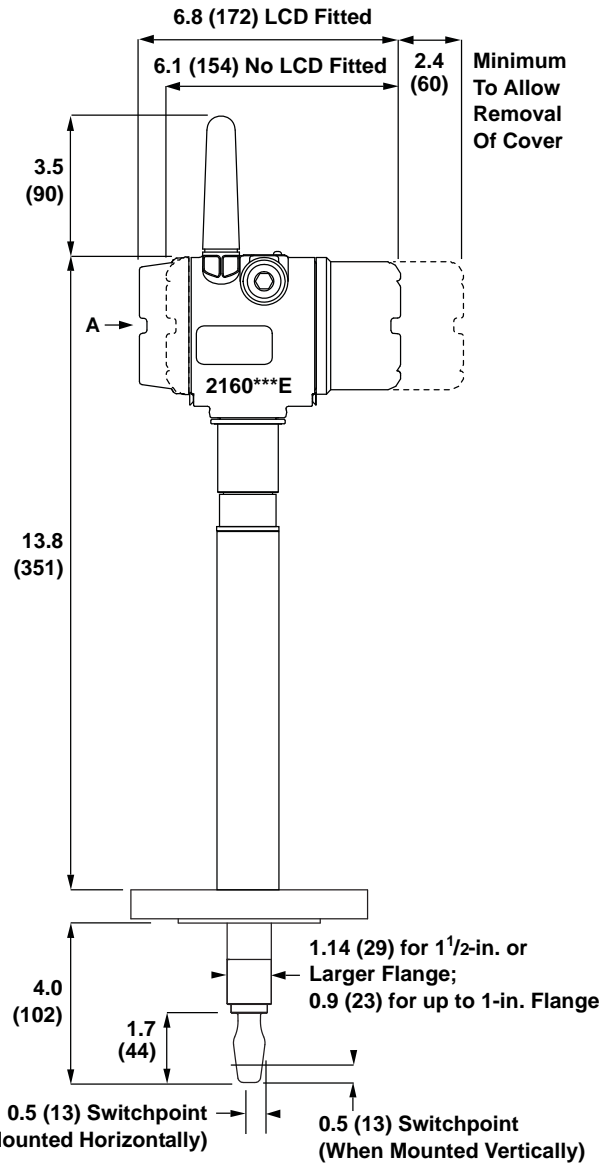
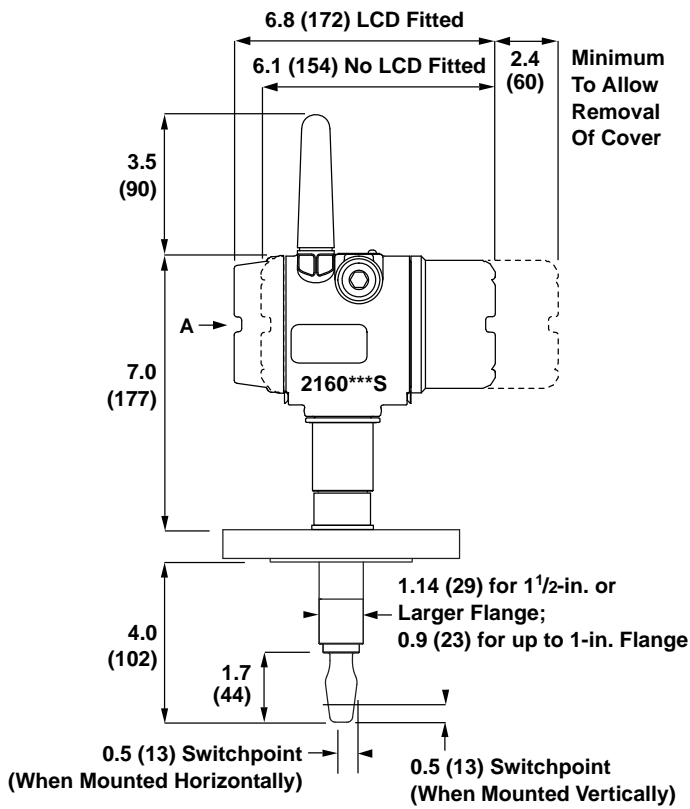

2160 Flange Mounting (Extended Length)

Note: Dimensions are in inches (millimeters)

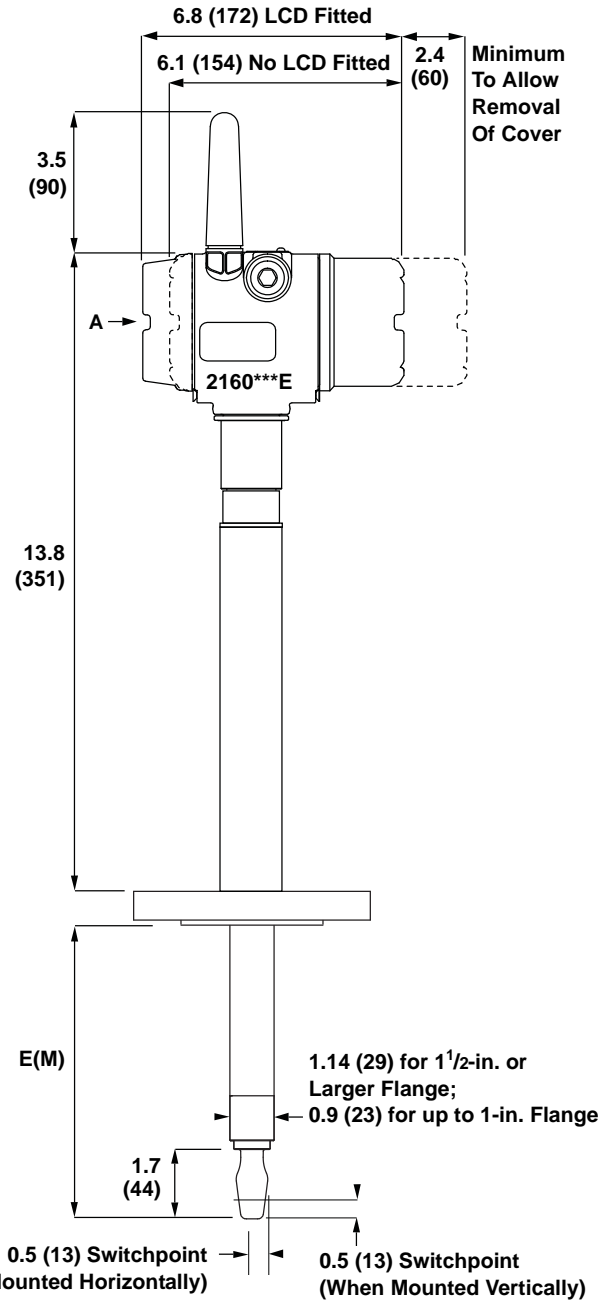
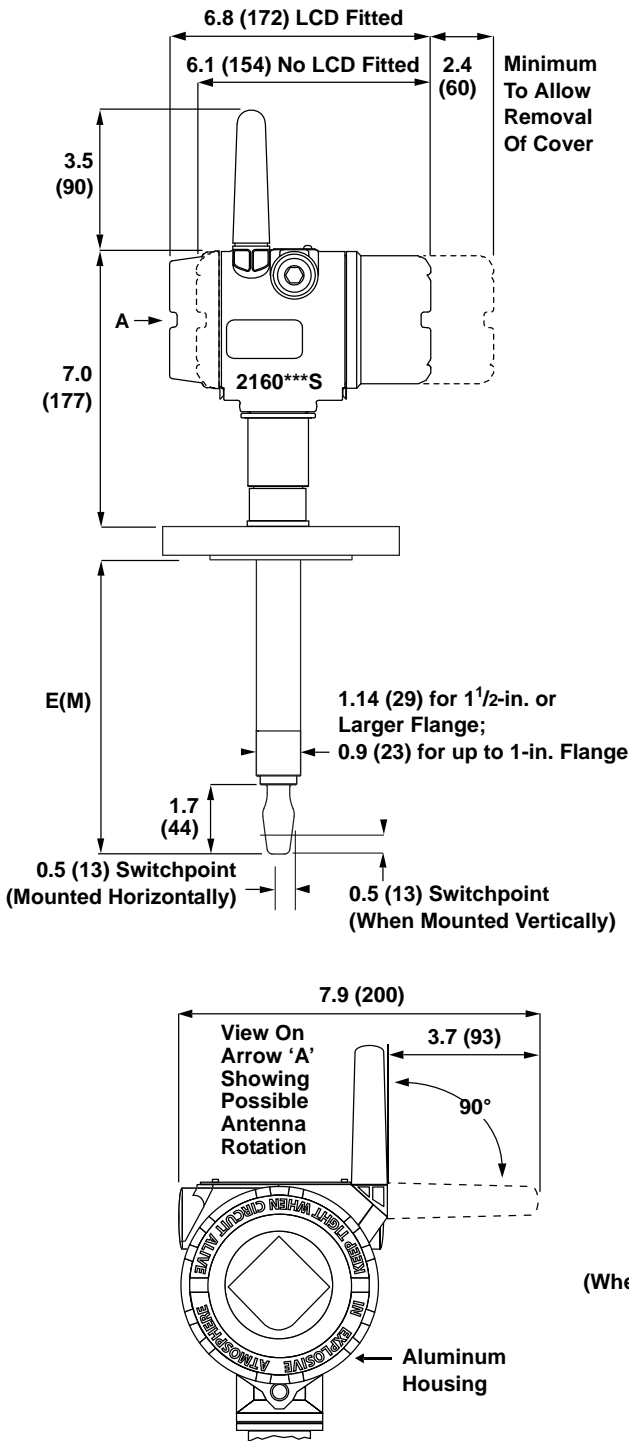
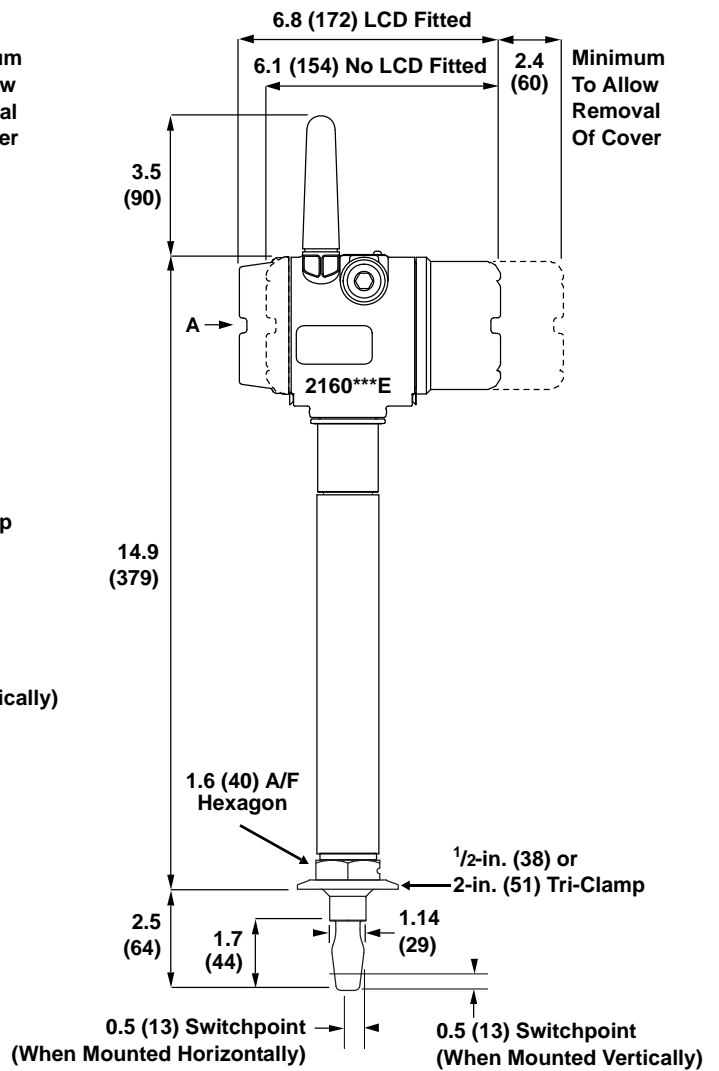
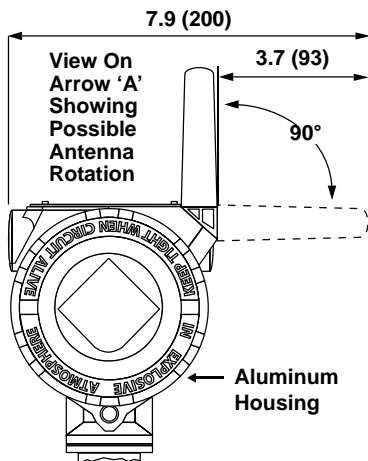
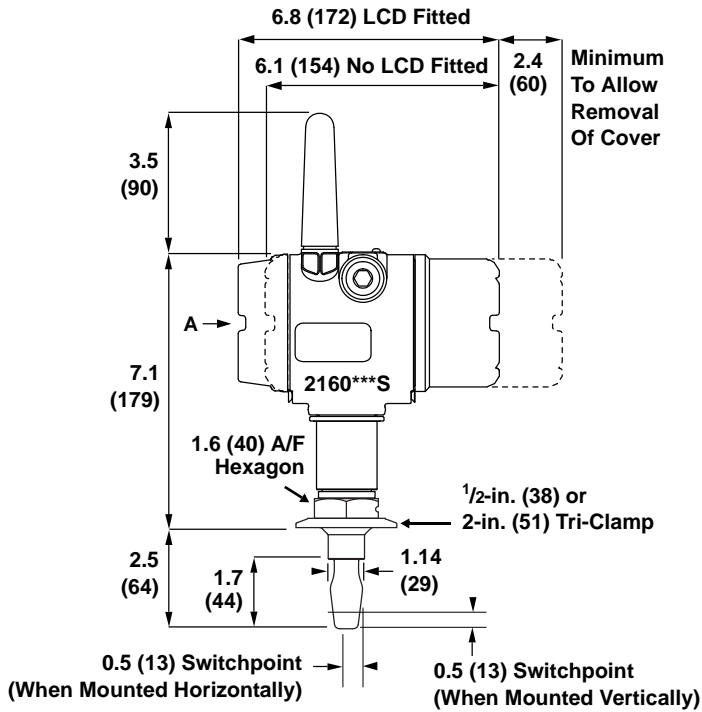

Table A-5. Flange Mounting Fork Length

Process Connection	Standard Length Fork Length Code H	Minimum Length Fork Length Code E(M)	Maximum Length Fork Length Code E(M)
3/4-in, 1-in. or larger flange	4.0 in. (102 mm)	3.5 in. (89 mm)	118.1 in. (3000 mm)

2160 Hygienic Fitting (Standard Length)

Note: Dimensions are in inches (millimeters)



2160 Hygienic Fitting (Standard Length) Continued

Note: Dimensions are in inches (millimeters)

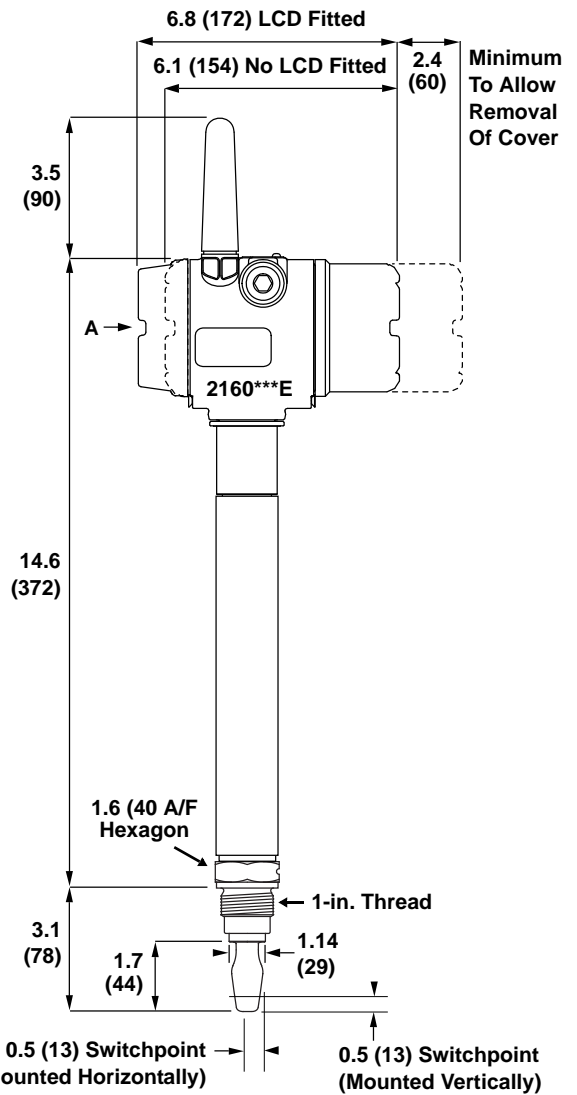
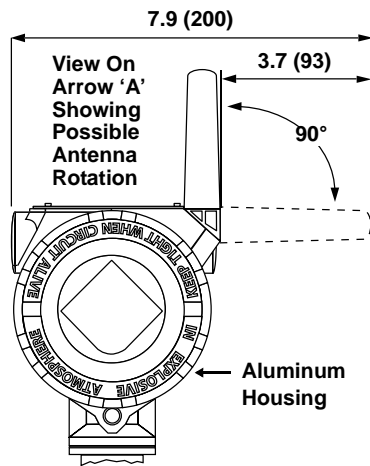
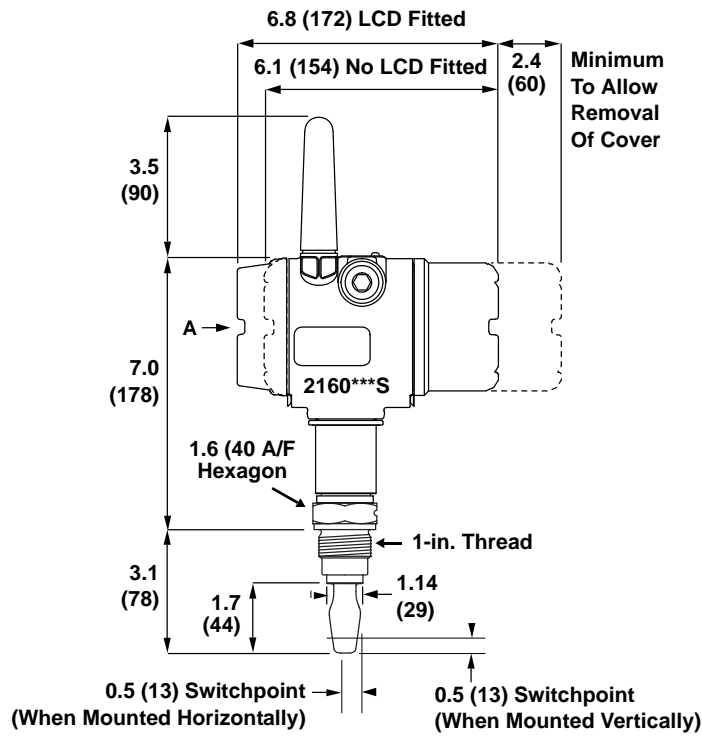

Rosemount 2160

2160 Hygienic Fitting (Extended Length)

Note: Dimensions are in inches (millimeters)

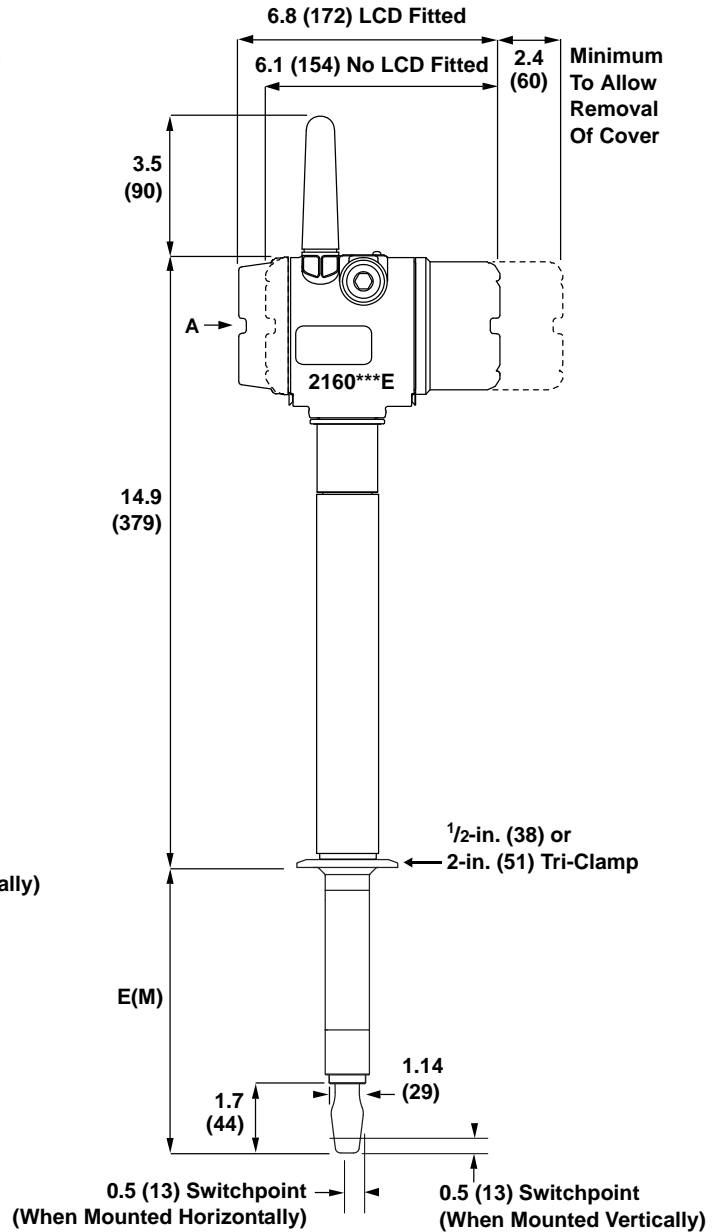
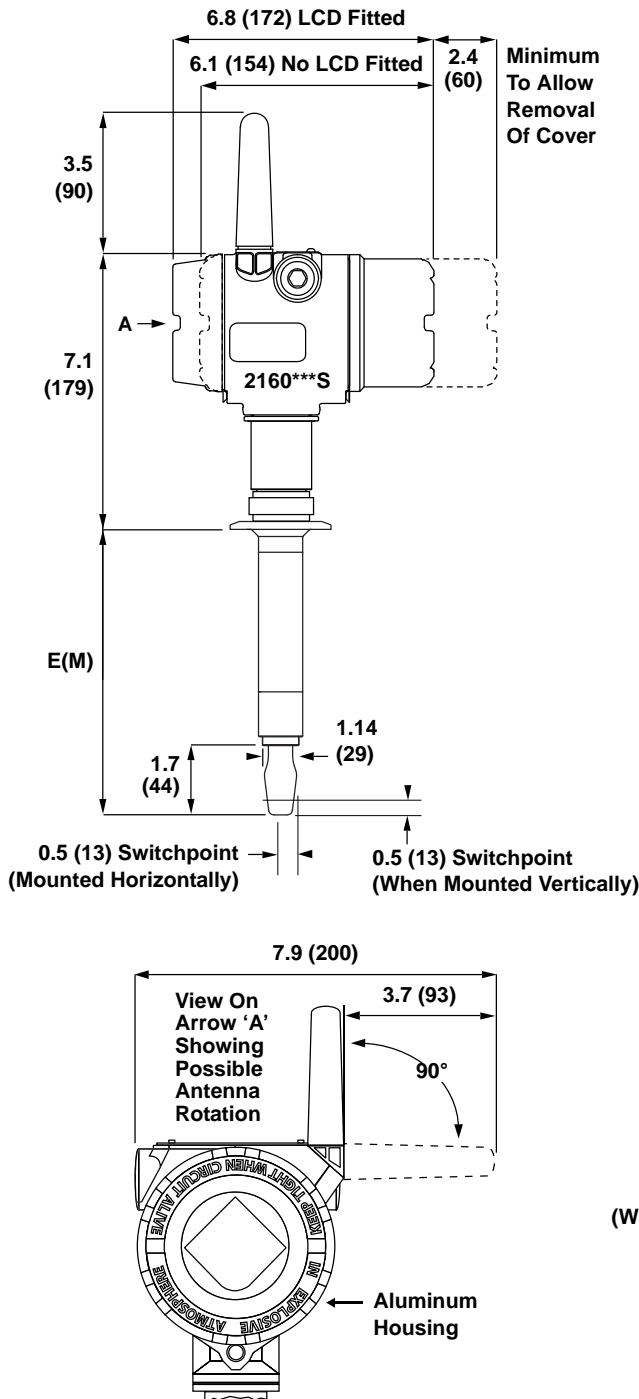

Table A-6. Hygienic Fitting Fork Length

Process Connection	Standard Length Fork Length Code H	Minimum Length Fork Length Code E(M)	Maximum Length Fork Length Code E(M) ⁽¹⁾
Tri-Clamp	1.73 in. (44 mm)	4.13 in. (105 mm)	118.1 in. (3000 mm)
1-in. Threaded	1.73 in. (44 mm)	(No Extended Length Version)	(No Extended Length Version)

(1) Maximum extended length of fork with hand-polished option is 39.4 in. (1000 mm).

ORDERING INFORMATION

Table A-7. 2160 Ordering Information

★ The Standard offering represents the most common options. The starred options (★) should be selected for best delivery. The Expanded offering is subject to additional delivery lead time.

Model	Product Description	
2160	Wireless Vibrating Fork Liquid Level Switch	
Output		
Standard		Standard
X	Wireless	★
Housing Material		
Standard		Standard
D	Dual Compartment Housing - Aluminum (Aluminium)	★
Conduit Entry / Cable Threads		
Standard		Standard
8	1/2-in. NPT thread	★
Operating Temperature		
Standard		Standard
S	Standard: -40 °F (-40 °C)...302 °F (150 °C)	★
E	Extreme: -94 °F (-70 °C)...500 °F (260 °C)	★
Material of Construction: Process Connection / Fork		
Standard		Standard
S ⁽¹⁾	316/316L Stainless Steel (1.4401/1.4404)	★
Expanded		
H ⁽²⁾	Alloy C (UNS N10002), Alloy C-276 (UNS N10276), solid	
Process Connection Size		
Standard		Standard
9	3/4 in.	★
1	1 in. / 25 mm (DN25)	★
2	2 in. / 50 mm (DN50)	★
5	1 1/2 in. / 40 mm (DN40)	★
3	3 in. / 80 mm (DN80)	★
4	4 in. / 100 mm (DN100)	★
6	6 in. / 150 mm (DN150)	★
8	8 in. / 200 mm (DN200)	★
7	2 1/2-in. / 65 mm (DN65)	★
Expanded		
X ⁽³⁾	Customer specific	
Process Connection Rating		
Standard		Standard
AA	ASME B16.5 Class 150 flange	★
AB	ASME B16.5 Class 300 flange	★
DB	EN1092-1 PN25/40 flange	★
NN	For use with non-flange process connection type	★
Expanded		
AC	ASME B16.5 Class 600 flange	
DA	EN1092-1 PN10/16 flange	
DC	EN1092-1 PN63 flange	
DD	EN1092-1 PN100 flange	
XX ⁽³⁾	Customer specific	
Process Connection Type		
Standard		Standard
R	Raised Face (RF) flange	★
B	BSPT (R) thread	★
G	BSPP (G) thread	★
N	NPT thread	★

Rosemount 2160

Table A-7. 2160 Ordering Information

★ The Standard offering represents the most common options. The starred options (★) should be selected for best delivery. The Expanded offering is subject to additional delivery lead time.

P	BSPP (G) O-ring	★
C	Tri-Clover Clamp	★
Expanded		
X ⁽³⁾	Customer specific	
Fork Length		
Standard		Standard
A	Standard length 1.7-in. (44 mm)	★
H ⁽⁴⁾	Standard length flange 4.0-in. (102 mm)	★
E ⁽⁵⁾	Extended, customer specified length in tenths of Inches	★
M ⁽⁵⁾	Extended, customer specified length in millimeters	★
Specific Extended Fork Length		
Standard		Standard
0000	Factory default length (only if fork length A or H is selected)	★
xxxx ⁽⁵⁾	Specific customer specified length in tenths of inches, or millimeters (xxxx mm or xxx.x inches)	★
Surface Finish		
Standard		Standard
1	Standard surface finish	★
2	Hand polished (Ra < 0.4 μm)	★
Product Certifications		
Standard		Standard
NA	No hazardous locations certifications	★
I1	ATEX Intrinsic Safety	★
I3	NEPSI Intrinsic Safety	★
I5	FM Intrinsic Safety	★
I6 ⁽⁶⁾	CSA Intrinsic Safety	★
I7	IECEX Intrinsic Safety	★
Wireless Update Rate, Operating Frequency and Protocol		
Standard		Standard
WA3	User configurable update rate, 2.4 GHz DSSS, IEC 62591 (WirelessHART)	★
Omnidirectional Wireless Antenna and SmartPower		
Standard		Standard
WK1 ⁽⁷⁾	External antenna, adapter for black power WK1 module (I.S. power module sold separately)	★
OPTIONS		
Meter		
Standard		Standard
M5	LCD meter	★
Factory Configuration		
Standard		Standard
C1 ⁽⁸⁾	Factory configure Date, Descriptor, Message Fields and Wireless Parameters	★
Calibration Data Certification		
Standard		Standard
Q4	Certificate of functional test	★
Material Traceability Certification		
Standard		Standard
Q8	Material traceability certification per EN 10204 3.1	★
Special Procedures		
Standard		Standard
P1 ⁽⁹⁾	Hydrostatic testing with certificate	★
Typical Model Number: 2160 X D 8 S S 1 NN N A0000 1 I5 WA3 WK1 M5 Q8		

(1) Flanges are dual certified 316 and 316L Stainless Steel (1.4401 and 1.4404).

(2) Only available of BSPT and NPT threaded process connection types as standard, other upon request.

(3) Other process connections available upon request.

(4) Not available for hand polished wet side.

- (5) Example: Code E1181 is 118.1 inches. Code M3000 is 3000 millimeters. See *Extended Lengths* on page A-2 for minimum and maximum extended lengths.
- (6) The requirements of CRN are met when a Rosemount 2160 CSA-approved vibrating fork level switch model 2160****S*****J6***** is configured with 316/316L stainless steel (1.4401/1.4404) wetted parts and either NPT threaded or 2-in. to 8-in. ASME B16.5 flanged process connections.
- (7) Black power module must be shipped separately, order Model 701PBKKF or part number 00753-9220-0001.
- (8) A Configuration Data Sheet (CDS) can be downloaded from the "Documentation and Drawings" area or 2160 product page on www.rosemount.com. Submit a completed CDS with the order if the C1 option code is selected
- (9) Option limited to units of no more than 59.1-in. (1500 mm) extended lengths.

Spare Parts and Accessories

Table A-8. Spare Parts and Accessories

★ The Standard offering represents the most common options. The starred options (★) should be selected for best delivery. The Expanded offering is subject to additional delivery lead time.

Spares and Accessories		
Standard		Standard
02100-1000-0001	Seal for 1-in. BSPP (G1A). Material: Non-asbestos BS7531 grade X carbon fiber with rubber binder	★
02100-1040-0001	Seal for 3/4-in. BSPP (G3/4A). Material: Non-asbestos BS7531 grade X carbon fiber with rubber binder	★
02100-1010-0001	Hygienic adaptor boss 1-in. BSPP. Material: 316 SS fitting. FPM/FKM o-ring	★
02100-1020-0001	2-in. (51 mm) Tri-clamp kit (vessel fitting, clamp ring, and seal). Material: 316 St. steel, NBR Nitrile	★
02120-2000-0001 ⁽¹⁾	1 ¹ / ₂ -in. BSPP adjustable clamp gland for 1-in. extended lengths. Material: 316 St. steel, (Si) Silicone rubber seal	★
02120-2000-0002 ⁽¹⁾	1 ¹ / ₂ -in. NPT adjustable clamp gland for 1-in. extended lengths. Material: 316 St. steel, (Si) Silicone rubber seal	★

(1) The adjustable clamp gland is not explosion-proof.

Appendix B Product Certifications

European Directive Information	page B-1
Telecommunication Compliance	page B-1
FCC and IC Approvals	page B-1
Canadian Registration Number	page B-2
Hazardous Locations Certifications	page B-2

EUROPEAN DIRECTIVE INFORMATION

The EC declaration of conformity for all applicable European directives for this product can be found at www.rosemount.com. A hard copy may be obtained by contacting an Emerson Process Management representative.

ATEX Directive (94/9/EC)

Emerson Process Management complies with the ATEX Directive

European Pressure Equipment Directive (PED) (97/23/EC)

The 2160 is outside the scope of PED Directive

L.V. Directive

EN61010-1 Pollution degree 2, Category II (264 V max.), Pollution degree 2, Category III (150 V max.)

Electro Magnetic Compatibility (EMC) (2004/108/EC)

EN 61326-1:2006

Radio and Telecommunications Terminal Equipment Directive (R&TTE)(1999/5/EC)

Emerson Process Management complies with the R&TTE Directive

TELECOMMUNICATION COMPLIANCE

All wireless devices require certification to ensure that they adhere to regulations regarding the use of the RF spectrum. Nearly every country requires this type of product certification. Emerson is working with governmental agencies around the world to supply fully compliant products and remove the risk of violating country directives or laws governing wireless device usage. To see which countries our devices have received certification for use in, see www.rosemount.com/smartwireless.

FCC AND IC APPROVALS

This device complies with part 15 of the FCC Rules. Operation is subject to the following two conditions: (1) This device may not cause harmful interference, and (2) this device must accept any interference received, including interference that may cause undesired operation.

FCC ID: LW2RM2510
IC ID: 2731A-RM2510

Rosemount 2160

CANADIAN REGISTRATION NUMBER

CRN 0F04227.2C

NOTE:

Rosemount 2160 CSA-approved vibrating fork level switch model 2160****S*****I6***** when configured with 316/316L stainless steel (1.4401/1.4404) wetted parts and either NPT threaded process or 2 in. to 8 in. ASME B16.5 flanged process connections meets the requirements of CRN.

HAZARDOUS LOCATIONS CERTIFICATIONS

American and Canadian Approvals

Factory Mutual (FM) Approvals

I5 Project ID: 3036541
FM Intrinsic Safety, Non-incendive, and Dust Ignition-proof
Intrinsically Safe for Class I/II/III, Division 1, Groups A, B, C, D, E, F, G.
Zone Marking: Class I, Zone 0, AEx ia IIC
Temperature Codes T4 ($T_a = -50$ to 70 °C)
Non-incendive for Class I, Division 2, Groups A, B, C, and D.
Dust Ignition-proof for Class II/III, Division I, Groups E, F, and G.
Ambient temperature limits: -50 to 70 °C
For use with Rosemount SmartPower® options P/N 753-9220-0001 only
Enclosure Type 4X / IP66

Specific condition of safe use

1. Warning – Potential Electrostatic Charging Hazard – The enclosure is partially constructed from plastic. To prevent the risk of electrostatic sparking, use only a damp cloth to clean the plastic surfaces.

Canadian Standards Association (CSA) Approvals

I6 Certificate Number: 06 CSA 1786345
CSA Intrinsically Safe
Intrinsically Safe for Class I, Division 1, Groups A, B, C, and D.
Temperature Code T3C
Enclosure Type 4X / IP66
Intrinsically Safe when installed in accordance with Rosemount drawing 71097/1271 (see Figure B-1 on page B-5)
For use with Rosemount SmartPower options P/N 753-9220-0001 only
Single Seal

European Approvals

ATEX Approvals

I1 ATEX Intrinsic Safety
Certificate Number: Baseefa 09ATEX0253X
II 1 G, Ex ia IIC T5-T2 ($T_a = -40$ to 70 °C)
IP66

Special conditions for safe use:

1. The surface resistivity of the antenna is greater than 1 gigaohm. To avoid electrostatic charge build-up, it must not be rubbed or cleaned with solvents or a dry cloth.
2. The Rosemount 2160 enclosure is made of aluminum alloy and given a protective epoxy coating; however, care should be taken to protect it from impact or abrasion if located in a Zone 0.

Rest Of The World Approvals

IECEX Approvals

I7 IECEX Intrinsic Safety

Certificate Number: IECEX BAS 09.0123X

Ex ia IIC T5-T2 ($T_a = -40$ to 70 °C)

IP66

For use with Rosemount SmartPower options P/N 753-9220-0001 only

Special conditions for safe use:

1. The surface resistivity of the antenna is greater than 1 gigaohm. To avoid electrostatic charge build-up, it must not be rubbed or cleaned with solvents or a dry cloth.
2. The Rosemount 2160 enclosure is made of aluminum alloy and given a protective epoxy coating; however, care should be taken to protect it from impact or abrasion if located in a Zone 0.

National Supervision and Inspection Centre (NEPSI) Approvals

I3 NEPSI Intrinsic Safety
Certificate: GYJ101138X
Ex ia IIC T5-T2

Description:

The 2160 Wireless Vibrating Fork Liquid Level Switch (hereinafter Wireless Level Switch), manufactured by Mobrey Limited, has been certified by the National Supervision and Inspection Center for Explosion Protection and Safety of Instrumentation (NEPSI).

The Wireless Level Switch accords with **GB 3836.1-2000** and **GB 3836.4-2000** standards.

The Wireless Level Switch has protection type of **Ex ia IIC T5~T2**.

Special Conditions For Safe Use:

1. Symbol “X” is used to denote specific conditions of use:
 - a. Model 648 WTT or Model 3051S WPT type battery pack provided by the manufacturer should be used
 - b. The surface resistivity of the antenna is greater than 1 gigaohm. To avoid electrostatic charge build-up, it must not be rubbed or cleaned with solvents or a dry cloth
 - c. The Rosemount 2160 enclosure is made of aluminum alloy and given a protective epoxy coating. However, care should be taken to protect it from impact or abrasion if located in a Zone 0.
2. The relationship between temperature class, ambient temperature range, and maximum temperature of process medium is as follows:

Temperature Class	Ambient Temperature Range	Maximum Temperature of Process Medium
T5	-50 to 40 °C	-70 to 80 °C
T4	-50 to 80 °C	-70 to 115 °C
T3	-50 to 80 °C	-70 to 185 °C
T2	-50 to 80 °C	-70 to 260 °C

3. End users are not permitted to change any components inside. (See “Service Support” on page 1-9 for contact information)
4. During installation, use and maintenance of the Wireless Level Switch, the following standards are to be observed:
 - **GB3836.13-1997**
“Electrical apparatus for explosive gas atmosphere Part 13: Repair and overhaul for apparatus used in explosive gas atmosphere”.
 - **GB3836.15-2000**
“Electrical apparatus for explosive gas atmosphere Part 15: Electrical installations in hazardous area (other than mines)”.
 - **GB3836.16-2006**
“Electrical apparatus for explosive gas atmosphere Part 16: Inspection and maintenance of electrical installation (other than mines)”.
 - **GB50257-1996**
“Code for construction and acceptance of electric device for explosive atmospheres and fire hazard electrical equipment installation engineering”.

Figure B-1.
CSA Control Drawing

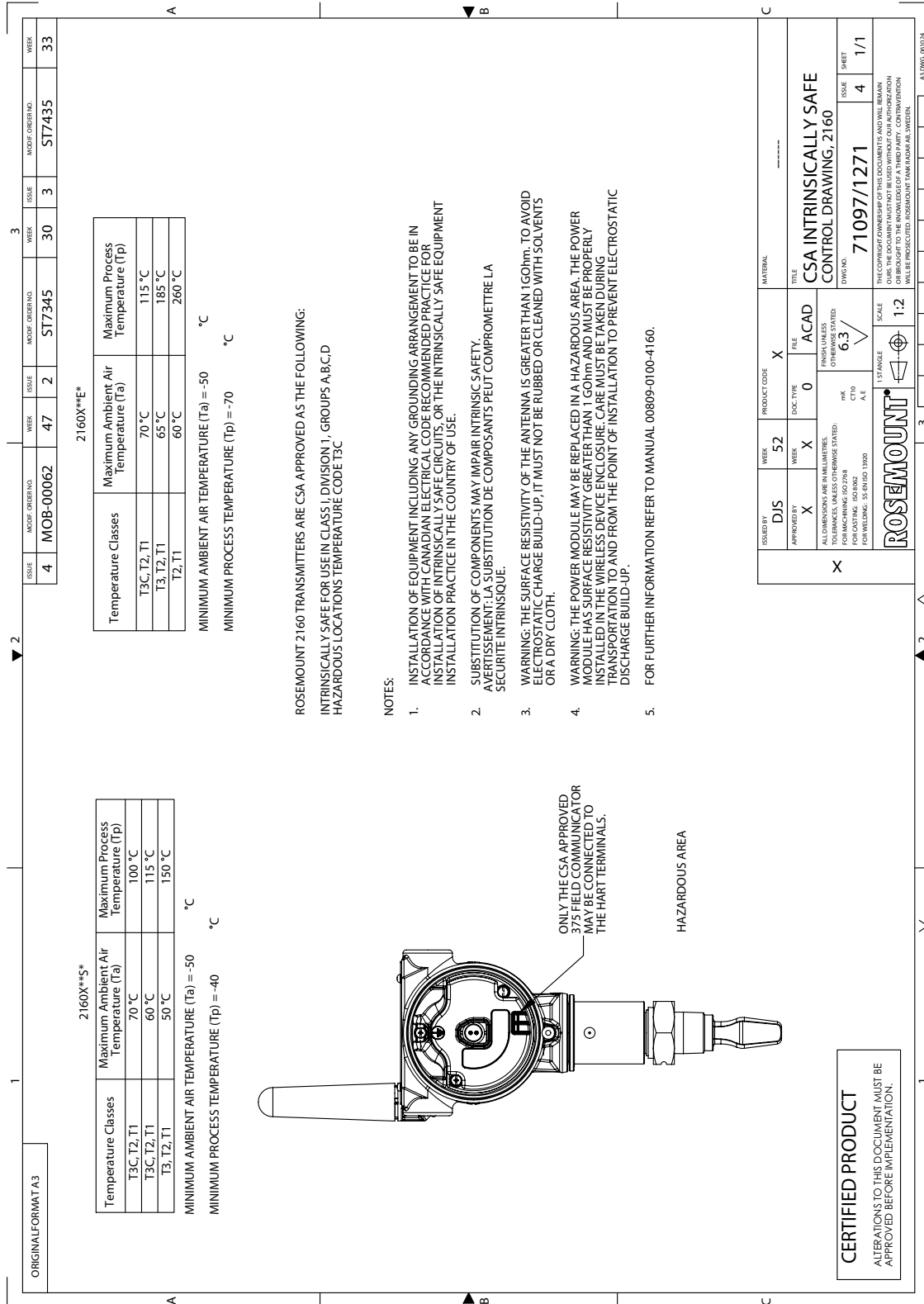

Standard Terms and Conditions of Sale can be found at www.rosemount.com/terms_of_sale

*The Emerson logo is a trade mark and service mark of Emerson Electric Co.
Rosemount and the Rosemount logotype are registered trademarks of Rosemount Inc.
PlantWeb is a mark of one of the Emerson Process Management companies.
HART is a registered trademark of the HART Communications Foundation.
All other marks are the property of their respective owners.*

© 2013 Rosemount, Inc. All rights reserved.

**Emerson Process Management
Rosemount Measurement**
8200 Market Boulevard
Chanhassen MN 55317 USA
Tel (USA) 1 800 999 9307
Tel (International) +1 952 906 8888
Fax +1 952 906 8889

**Emerson Process
Management GmbH & Co.**
Argelsrieder Feld 3
82234 Wessling
Germany
Tel 49 (8153) 9390
Fax 49 (8153) 939172

**Emerson Process Management
Asia Pacific Pte Ltd**
1 Pandan Crescent
Singapore 128461
T (65) 6777 8211
F (65) 6777 0947
Enquiries@AP.EmersonProcess.com

**Beijing Rosemount Far East
Instrument Co., Limited**
No. 6 North Street,
Hepingli, Dong Cheng District
Beijing 100013, China
T (86) (10) 6428 2233
F (86) (10) 6422 8586